

CDA3000

Order catalogue

Drive solutions
750 W up to 132 kW

With firmware:

Basis - for universal use

PLC - for machine sub-automation
units



**The fast track to your
order**

Order Catalogue Inverter Systems CDA3000

Id.-No.: 0840.24 B.4-00

Stand: January 2004

We reserve the right to make technical changes.

The drive controller with **c-line** technology

The particular benefits to users of LUST drive controllers lie in the expert solutions delivered for automation with electric drives and in the high level of control engineering know-how available to handle the control of a wide range of motor types. Always keeping an eye on the physics, looking to make electric drive engineering the core element of machine optimisation and automation.

It is a long-established fact in electric drives that the various control methods can complement each other effectively in handling complex automation tasks. The best solution for complex motion tasks will always depend largely on the individual requirements of the user and on the provider's experience and range of equipment. It is therefore a decided advantage if all options can be tapped easily and without changing the equipment concept or even the provider.

Our focus is on custom drive solutions with our:

- Inverter systems 0.75 kW to 132 kW
- Servo system
 - with asynchronous motors up to 425 Nm
 - with synchronous motors up to 245 Nm
- direct-drive system
 - - with hollow shaft motors up to 75 Nm
 - - with linear motors up to 20,000 N

Inverters and servocontrollers based on the same concept

The **c-line** DRIVES are ideal for virtually any task. They include the CDE/CDB inverters with the Voltage Frequency Control (VFC) method, Field Oriented Regulation (FOR) with encoder evaluation, and Sensorless Flux Control (SFC). The CDD servocontrollers include a highly dynamic speed/torque/position control. For applications with high-torque motors there is the CTC TORQUECHAMPION for direct drives.

All **c-line** DRIVES drive controllers have the same basis, with a wide range of variants for specific solutions. A platform of this kind enables rapid, cost-effective response to new developments.

Common features of the **c-line** DRIVES :

- their design, metal enclosure and cooling method for
 - wall mounting
 - cold plate
 - push-through heat sink
- their excellent EMC performance
- their user-friendly operation with the DRIVEMANAGER PC tool
- easy serial startups with KEYPAD and Chipcard
- the modular networking concept
- the comprehensive range of accessories and complementary components

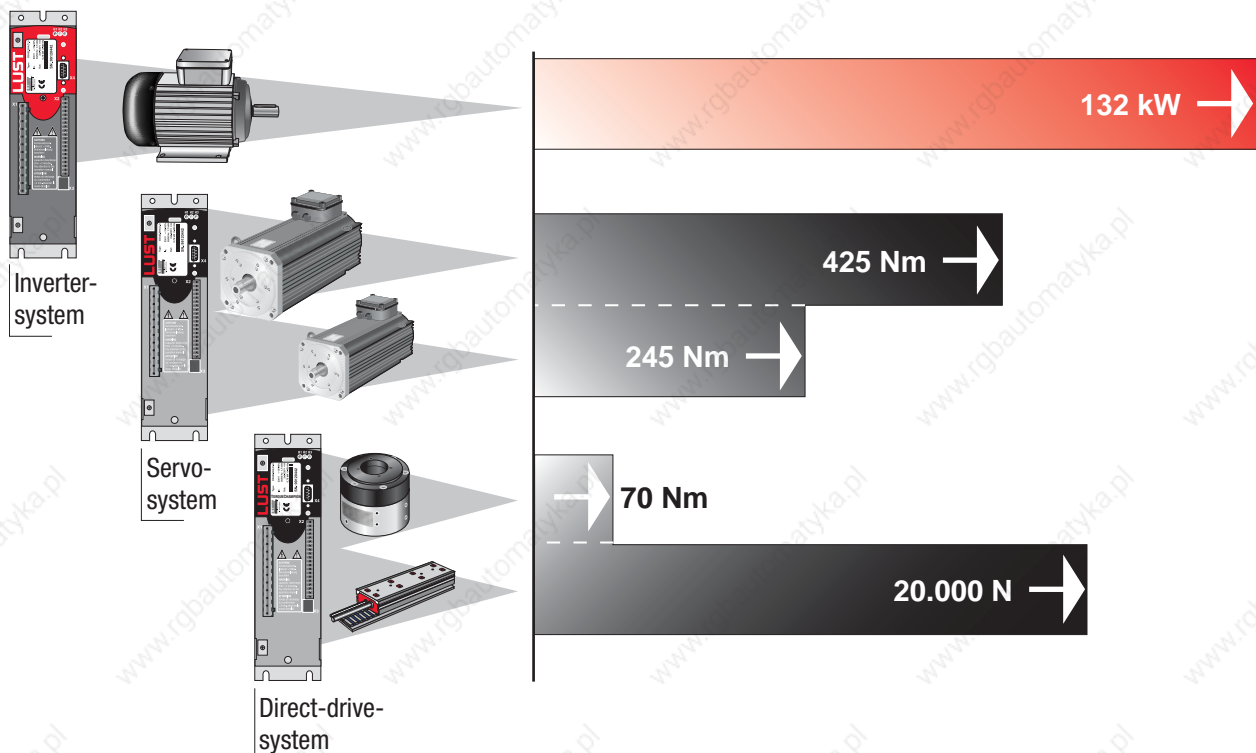



Inverter drive system CDA3000 1-1
Features..... 1-3
Acceptance tests 1-4
Cooling methods 1-5
Motor control method 1-6



Easy first commissioning.....	1-7
Basic-Firmware	1-8
PLC-Firmware.....	1-9
Service	1-11

System summary



Current load capacity of inverter modules.....	2-2
CDA3000 up to 7,5 kW.....	2-4
CDA3000 up to 15 kW.....	2-12
CDA3000 up to 37 kW.....	2-14
CDA3000 up to 55 kW.....	2-16
CDA3000 up to 132 kW.....	2-18

Inverter modules

2



Operator modules	3-2
Operator Panels + cables	3-4
PLCeditor.....	3-10
DRIVEMANAGER	3-11
Terminal cover	3-13
EMV-shield connection.....	3-14
Heat sink BG1 + BG2	3-16

Accessories for inverter modules

3



User modules	
UM-8140(Terminal extension)....	4-2
Communication modules	
CM-CAN1 (CAN _{Lust})	
CM-CAN2 (CAN _{open})	
CM-DPV1 (PROFIBUS-DP)	4-3
Mounting set/Modules.....	4-5

User and communication modules

4



Line chokes.....	5-2
Braking resistors	5-5
Mains filter	5-8
Motor choke and filter	5-12
Inverter ED1200 for simple applications.....	5-16
User information	5-17

Supplementary components

5

Inverter system CDA3000

Experience and vision

CDA 3000 is the result of years of practical experience in drive technology for automation of machinery and plant. This inverter system is fit for the ever shortening innovation cycle in the automation of machinery.

Founded on tradition

We have continued our long-standing tradition of setting control standards in the drive technology as well as creating standards for the future-oriented flexibility in machinery and plant.

Fit for the future

The inverter module is the central unit of the system and information carrier for the various operator, user and communication modules. All modules are standalone components with all necessary certificates and are tested in terms of connectivity. The interfaces to the docking modules are open for new automation design concepts in future.

Very easy setting via automatic identification of the motor and by means of self-setting of all control circuits. The motto of the CDA3000 is „Starting and run“.

Fast and easy

The concept of the new inverter system is that the user can configure and commission the optimum drive solution more easily and faster, in spite of extended functions and extensive system components.

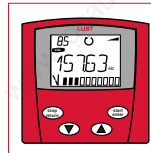

With KEYPAD and the PC-user software DRIVEMANAGER comfortable setting and analysis possibilities are available for all LUST drive controllers. They convince by their stability and didactic sophistication.

Ready-made solutions for traction, lifting and rotation drives highlight only the important parameters. The underlying complexity can only be guessed.

EMV with safety

All devices from 750 W up to 132 kW with sheet-steel housing with aluminium/zinc surface. The housing offers a high protection against interference to the direct environment. To reduce the interference RFI filters are always included in the inverter modules (up to 7.5 kW). This results in a reduction of expenditure as well as in the costs of the whole installation.

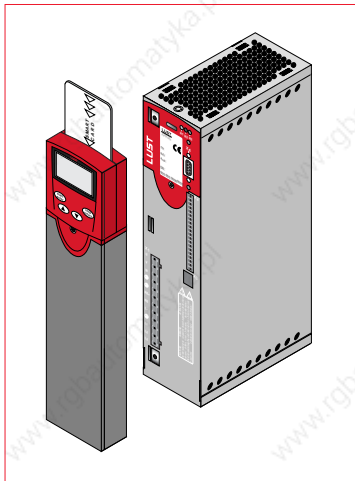

Keep cool

Fully used power components require a cool inverter. The modular cooling concept offers free selection of the given mounting method. Using cold plate or heat sink in- or outside the mounting place depends on the situation.

Automatically more torque

Mature new technologies results in functional improvements with reliable specifications. With the sensorless flux control (SFC) of LUST attributes like higher output torques, dynamic disturbance control and a wide

speed manipulating range can be safely and reproducibly achieved.

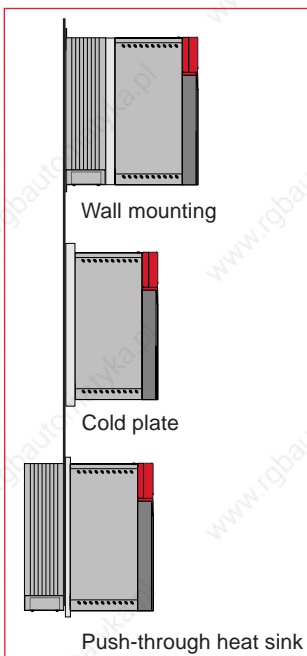

Wall mounting

Cold plate

Push-through heat sink

The system architecture for the flexible solutions of the future

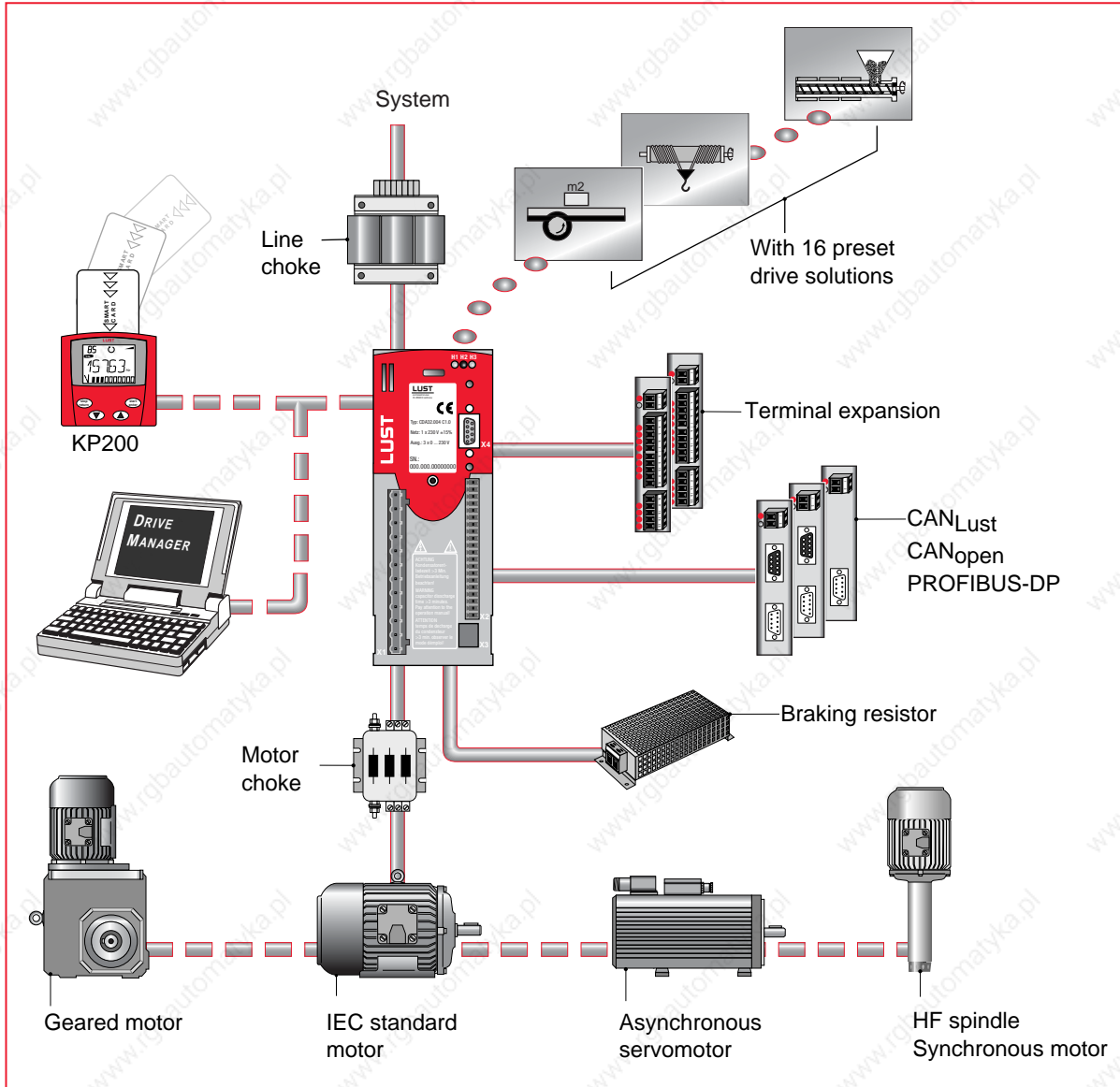

System selection

Invertermodule

Accessories for Invertermodule

User- und Communicationmodule

Supplementary Components

Features

Inverter modules for 230 V systems:

Inverter modules	Rec. 4-pole standard motor [kW]	Device rated power [kVA]	Rated current [A]	Peak current [A]	Size [BG]	Dimensions [mm] width x height x depth
CDA32.004,Cx.x	0.75	1.7	4.0 A	7.2 ¹⁾	BG1	70 x 193 x 152.5
CDA32.006,Cx.x	1.1	2.3	5.5 A	9.9 ¹⁾	BG2	70 x 218 x 177.5
CDA32.008,Cx.x	1.5	3.0	7.1 A	12.8 ¹⁾	BG2	70 x 218 x 177.5
Mains voltage 1 x 230 V -20 % +15 %					1) 1.8 x I _N for 30 s	
Cooling air temperature (1000 m above zero) 45 °C at power stage switching frequency 4 kHz						
Rotating field frequency 0 ... 400 Hz						

Inverter modules for 400/460 V systems:

Inverter modules	Rec. 4-pole standard motor [kW]	Device rated power [kVA]	Rated Current [A]	Peak current [A]	Size [BG]	Dimensions [mm] width x height x depth
CDA34.003,Cx.x	0.75	1.6	2.2	4.0 ¹⁾	BG2	70 x 218 x 177.5
CDA34.005,Cx.x	1.5	3.0	4.1	7.4 ¹⁾	BG2	70 x 218 x 177.5
CDA34.006,Wx.x	2.2	4.2	5.7	10.3 ¹⁾	BG2	70 x 218 x 177.5
CDA34.008,Wx.x	3.0	5.7	7.8	14 ¹⁾	BG3	70 x 303 x 250.5
CDA34.010,Wx.x	4.0	7.3	10	18 ¹⁾	BG3	70 x 303 x 250.5
CDA34.014,Wx.x	5.5	10.2	14	25 ¹⁾	BG4	120 x 303 x 250.5
CDA34.017,Wx.x	7.5	12.4	17	31 ¹⁾	BG4	120 x 303 x 250.5
CDA34.024,Wx.x	11	17.5	24	43 ¹⁾	BG5	170 x 303 x 250.5
CDA34.032,Wx.x	15	23.3	32	58 ¹⁾	BG5	170 x 303 x 250.5
CDA34.045,Wx.x	22	32.8	45	68 ²⁾	BG6	250 x 345 x 325
CDA34.060,Wx.x	30	43.8	60	90 ²⁾	BG6	250 x 345 x 325
CDA34.072,Wx.x	37	52.5	72	108 ²⁾	BG6	250 x 345 x 325
CDA34.090,Wx.x	45	65.6	90	135 ²⁾	BG7	300 x 550 x 305
CDA34.110,Wx.x	55	80.0	110	165 ²⁾	BG7	300 x 550 x 305
CDA34.143,Wx.x	75	104.0	143	214 ²⁾	BG8	412 x 500 x 362
CDA34.170,Wx.x	90	124.0	170	255 ²⁾	BG8	412 x 500 x 362
CDA34.250,Wx.x	132	173.0	250	300 ³⁾	BG8	412 x 500 x 362
Mains voltage 3 x 460 V -25 % +10 %					1) 1.8 x I _N for 30 s	
Rotating field frequency 0 ... 400 Hz (0,7 to 22 kW)					2) 1.5 x I _N for 60 s	
Rotating field frequency 0 ... 200 Hz (30 to 132 kW)						

Acceptance tests/ Ambient conditions

CE mark

The inverter modules¹⁾ meet the requirements of the Low Voltage Directive DIN EN 50178 and of the product norm EN 61800-3 (EMV).

The inverter modules¹⁾ thus meet the requirements for the installation in a machine or plant under the terms of the Machinery Directive 98/37/EG.

The inverter modules CDA3000¹⁾ are marked according to CE. The CE mark on the name plate signifies conformance with the above mentioned directives.

On request we will be pleased to issue a Declaration of Conformity.

cUL approbation

The inverter modules¹⁾ 0,75 up to 55 kW have the cUL-approbation. For inverter modules¹⁾ 75 up to 132 kW the cUL approbation is in preparation. This cUL approbation is equivalent to UL and CSA approbation.

EMV acceptance tests

All inverter modules¹⁾ have a sheet-steel housing with an aluminium/zinc surface in order to enhance the interference resistance (acc. to EN61800-3, environments 1 and 2).

To limit line-bound interference emission to the permissible level, all inverter modules up to 7.5 kW are equipped with integrated mains filters, in order to comply with EMV product norm DIN EN 61800-3:

Public Low Voltage Network:
Residence up to 10 m motor cable

Industrial Low Voltage Network:
Industry up to 25 m motor cable

Additionally an extensive product line with external mains filters for side and substructure mounting is available. For detailed information see chapter „Supplementary Components“.

Feature		Inverter module	User and communication module and KP200
Operation temperature		-10 ...45 ° C (BG1 ... BG5) 0 ... 40 ° C (BG6 ... BG8) with power reduction up to 55 ° C	-10 ... 55 ° C
Storage temperature		-25 ... +55 ° C	
Transport temperature		-25 ... +70 ° C	
Relative air humidity		15 ... 85 %, condensation is not permitted	
Mechanical strength acc. IEC 68-2-6	during stationary use	Vibration: 0.075 mm in frequency range 10 ... 58 Hz Shock: 9.8 m/s ² in frequency range >58 ... 500 Hz	
	during transport	Vibration: 3.5 mm in frequency range 5 ... 9 Hz Shock: 9.8 m/s ² in frequency range >9 ... 500 Hz	
Protection	Device	IP20 (NEMA 1)	
	Cooling method	Cold Plate IP20 Push-through heat sink IP54 (3 ...15 kW)	Convection IP20
Touch protection		VBG 4	
Mounting height		up to 1000 m above MSL, over 1000 m above MSL with power reduction, max. 2000 m above MSL	

1) applies to user and communication modules, too.

Cooling methods

The basic model of the inverter offers three different mounting and cooling methods (e.g. size 3):

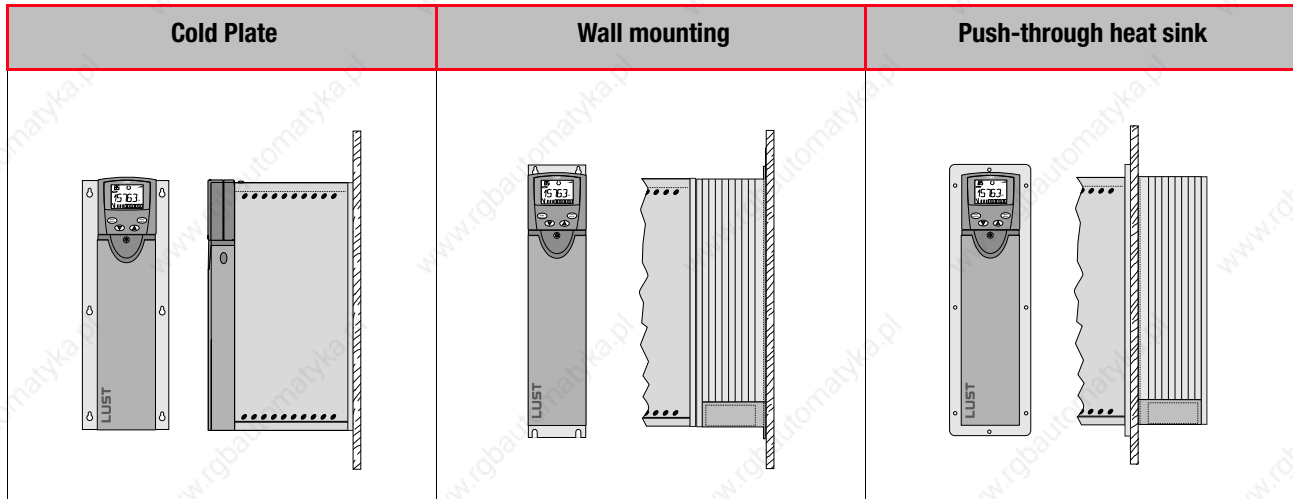

Size	Output	Inverter module	Cold Plate	Wall mounting	Push-through heat sink
BG1	0.75 kW	CDA32.004	YES	YES ¹⁾	NO
BG2	1.1 kW	CDA32.006	YES	YES ¹⁾	NO
	1.5 kW	CDA32.008			
	0.75 kW	CDA34.003			
	1.5 kW	CDA34.005			
BG2	2.2 kW	CDA34.006	YES ³⁾	YES	NO
BG3	3.0 kW	CDA34.008	YES ³⁾	YES	YES ²⁾
	4.0 kW	CDA34.010			
BG4	5.5 kW	CDA34.014	YES ³⁾	YES	YES ²⁾
	7.5 kW	CDA34.017			
BG5	11 kW	CDA34.024	YES ³⁾	YES	YES ²⁾
	15 kW	CDA34.032			
BG6	22 kW	CDA34.045	NO	YES	NO
	30 kW	CDA34.060			
	37 kW	CDA34.072			
BG7	45 kW	CDA34.090	NO	YES	NO
	55 kW	CDA34.110			
BG8	75 kW	CDA34.143	NO	YES	NO
	90 kW	CDA34.170			
	110/132 kW	CDA34.250			

1) Corresponds to cold plate with heat sink HS3X.xxx as accessories, not in design wall mounting CDA3 ..., Wx.x.
 2) Type of protection IP54
 3) For sufficient cooling an additional active cooler is necessary.

Motor control method

During commissioning of the inverter three different control methods can be selected.

The necessary identification of the motor is provided automatically by the inverter module based on the „start and run“ concept. All control circuits are optimized in the process as well.

Voltage frequency control (VFC)

With the VFC the voltage of the motor is changed proportionally to the output frequency of the inverter module. This method is suitable for drives of pumps, fans, extruders as well as traction and lifting drives with low dynamic equipped with special motors like reluctance motors.

Sensorless Flux Control (SFC)

The new control method SFC, applicable for asynchronous motors, calculates the rotor speed and the current angle of the rotor from the electrical variables. Based on the calculated information, the currents for the torque formation can favourably be fed into the motor. So it is possible to attain excellent control characteristics without using an expensive encoder.

Field-Oriented Regulation (FOR)

With the FOR rotor and speed positions are calculated with one encoder. Based on those measurement variables, flux and torque can be set independently. Maximum dynamic and high speed accuracy can be reached.

Characteristics	VFC Voltage frequency control	SFC Sensorless flux control	FOR Field-oriented regulation
Torque rise time	20-30 ms	< 2 ms	< 2 ms
Dynamic disturbance correction	NO	YES	YES
Standstill torque	NO	NO	YES
Acceleration torque ($I_{\text{Inverter}} = 2 \cdot I_{\text{Motor}}$)	$1.2 \cdot M_{\text{Nenn}}$	$1.8 \cdot M_{\text{Nenn}}$	$2 \cdot M_{\text{Nenn}}$
Current usage of inverter	60%	90%	100%
Anti-stall protection	limited	YES	YES
Speed manipulating range $M = M_{\text{Nenn}}$	1:20	1:20	1:10000
Static speed accuracy (refers to rated speed)	typically 1 to 5%	typically 0.5%	quartz accurate
Frequency resolution	0.01 Hz	0.0625 Hz	2^{-16} Hz
Motor principle	asynchronous synchronous reluctance	asynchronous	asynchronous

Easy first commissioning

With the PC-user software DRIVEMANAGER the first commissioning of the drive will be comfortable and plain. All you need to do is „click through“.

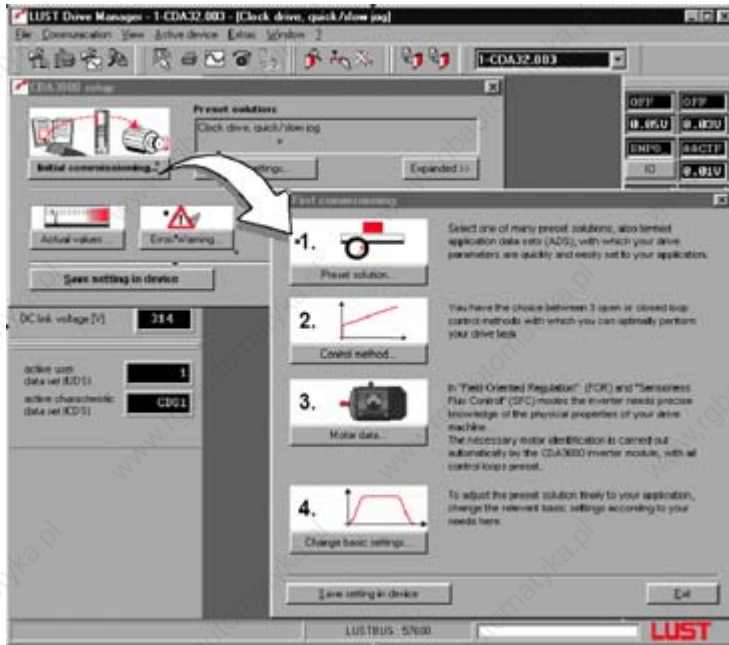

PC-user software DRIVEMANAGE „First commissioning“

1. Preset drive solution

Opens a dialog for selecting the required ready made settings via clicking-on.

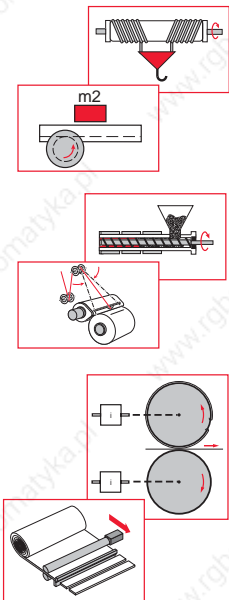

- Conveyor belt drive, rack drive, carriage drive and lifting drive
- Spindle drive, extruder, stirrer, disperser and winding drive
- Electronic gear for worm drives, pack distribution plants and master shaft replacement
- Network operation via CANopen or PROFIBUS-DP

2. Control method

Opens a dialog for selecting one of three control methods:

- Voltage frequency control
- Sensorless speed control
- Field-oriented regulation

3. Motor identification

Starts a menu, supporting you at the input of the motor plate data. The automatic identification of the connected asynchronous motor with the automatic parameter setting of the control circuits completes this step.

4. Basic setting

Starts a menu for fine-adjustment of your drive.

Basic - Firmware

Among the hardware aspects the efficiency of the device firmware will be more and more significant. Finally only the firmware has the intelligence for managing the movement tasks in machinery and plants.

The firmware of the inverter modules CDA3000 supports a number of application features, unthinkable some years ago. The application features can be activated via the graphic user interface, to solve the complete movement tasks acc. to the given situation.

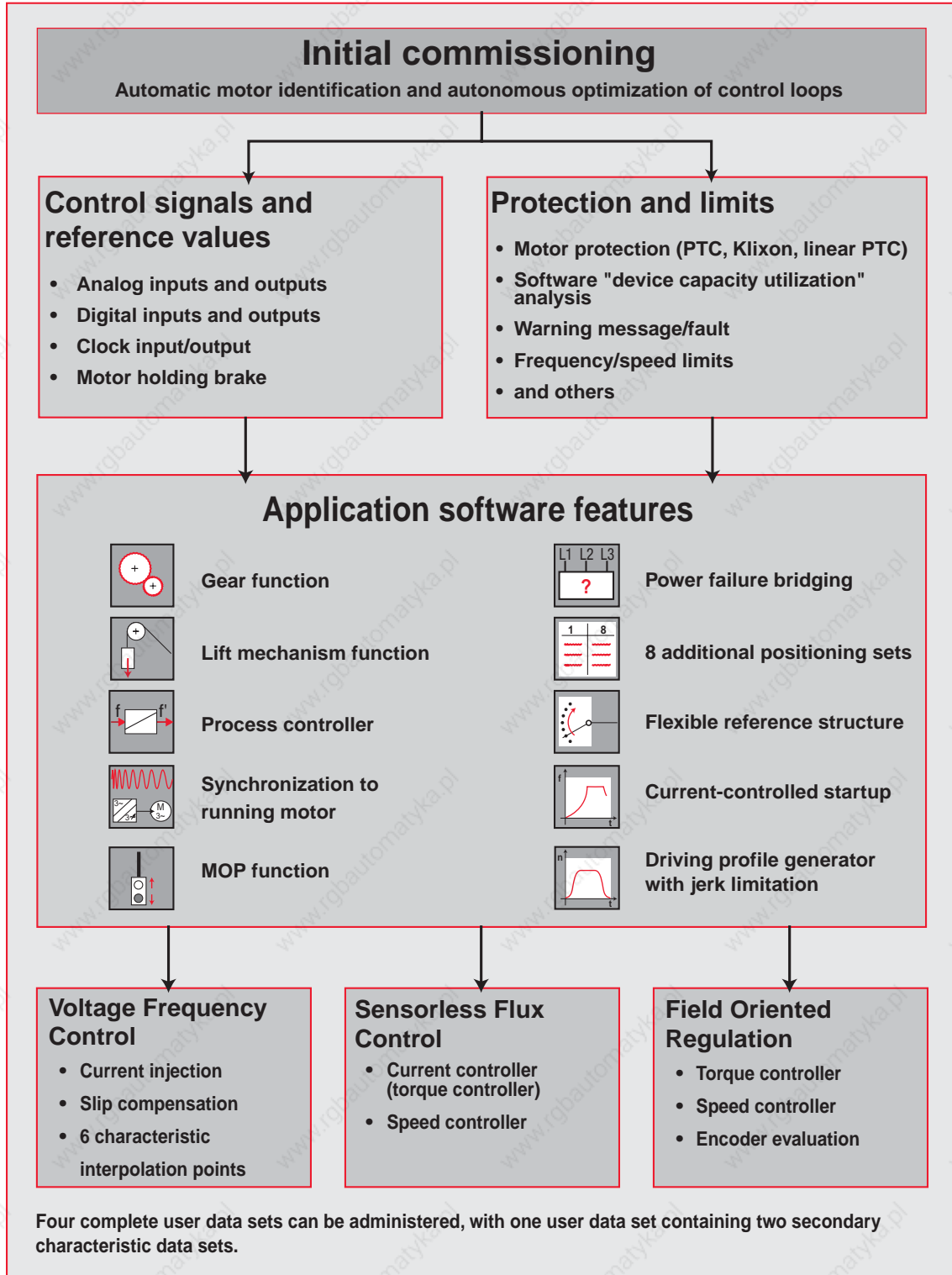

PLC-Firmware

The new PLC firmware consists of the software performance of the basic firmware and an extending PLC-user platform.

Execution of the basic firmware is possible without support of the four user data sets and motor identification via KEYPAD. Therefore we included support of the standard CAN_{OPEN} protocol, in order to manage the structure of a CAN_{OPEN} network via a low cost communication module CM-CAN1.

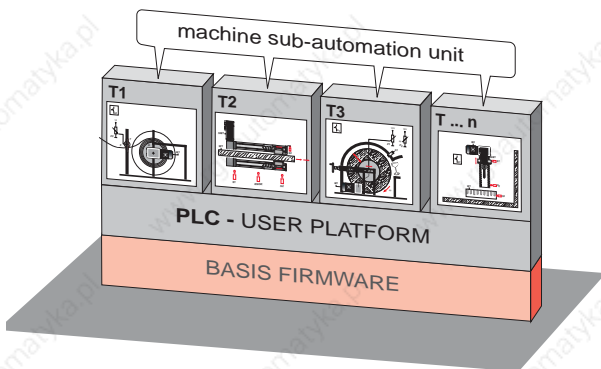

PLC-user Platform

Programming the PLC process program is line-oriented and similar to the program language BASIC. It reduces the time exposure for learning the amount of instructions. Furthermore it has the advantage that the user can read the programs without knowing the exact instruction sets.

PLC-Process Program allows

- flexible setting of control and reference information for all motor control types
- set/read analog and digital i/O's
- direct writing/reading access for all parameters
- mathematic operands (+, -, *, modulo, ABS, round)
- timer and counter functions (12 timer, 11 counter)
- using integer variables, floating point variables and flags
- easy position control

Instruction set consists of:

- Jump signals
- Subroutine call
- Set signals
- Wait signals
- Control, positioning and process signals

PLC-Editor

The PLC editor is a part of the PC-user software DRIVEMANAGER and only necessary for engineering and initial commissioning of your PLC program. The serial commissioning of inverter modules will be effected via the known DriveManager data set or the new SMARTCARD SC-XL.



The PLC-program editor offers the functions:

- Program generation
 - Editor for program generation
 - Generation of a text declaration file <project name>.txt for the variables to indicate application-specific tests in the DRIVEMANAGER
 - Syntax check of opcode
 - Renumbering line numbers
- Program handling:
 - Load/Save/Print/Regeneration of programs
 - Load/Save a program from/in a connected drive control.
 - Load/Save a program from/in DRIVEMANAGER-data sets
- Online help to PLC-Editor and to the command syntax with examples

All PLC-functions can be selected via function buttons.

New solution with PLC-firmware

The operational area of PLC-user platform for the generation of automation programs allows a number of new solutions. Solutions, supported by graduated series of Operator Panels.

Already solved machine sub-automation units are:

I/O oriented processes

Motion solution, mainly defining the sequences of the sub-automation process via I/O-signals from the working procedures. Typical applications are:

- Feed unit for drilling and lowering
- Belt and carriage drives
- Drives for doors and gates
- Pumping stations with float switch
- Lifting and rotating tables

Time-controlled processes

Motion solution, mainly defining the sequences of the sub-automation process temporarily. Typical applications are:

- Melting and mixing plants for paints
- different centrifuges and dispersers
- Mills and shredders

Regulated processes

Motion solution, to keep process sizes like torque, traction, pressure, temperature or position constant during the working procedure. It deals with sub-automation processes, like:

- Warbler or dancer control for winders
- Block protection control for shredder
- Simple positioning controls for drives of doors and gates, carriage and rotating drives
- classic pressure, temperature and flow control

Example: Drill feed unit

Process program

```
;Inputs:
;M001=Start feed
;IS01=Pre-stop opener
;IS02=Upper limit switch opener
;IS03=Lower limit switch closer
%TEXT (feed)
DEF H000 = Reference_0
DEF H001 = Timer_1
DEF M002 = Initialisation
DEF H002 = Quick-jog frequency
DEF H003 = Slow-jog frequency
DEF H004 = Waiting time
DEF H010 = Quick-jog_positive
DEF H011 = Quick-jog_negative
DEF H012 = Slow-jog_positive
DEF H013 = Slow-jog_negative
DEF M001 = Start motion
```

END



Bild: Bohrerschubereinheit

```
; Process program for CDA-PLC
%P00
N005 SET H000=0; Reference 0
N010 SET H001=1000; Value for timer 1
N015 JMP (M002=1) N031; Jump over initialising
N020 SET H002=70; Reference feed Hz
N030 SET H003=20; Slow-jog
N031 SET H004=200; Waiting time working point
N032 SET M002=1
N040 SET H010=H002; Variable quick-jog positive
N041 SET H011=H002; Variable quick-jog negative
N042 INV H011
N050 SET H012=H003; Variable slow-jog positive
N051 SET H013=H003
N052 INV H013
N060 JMP (M001=1) N100; Start feed motion
N065 JMP (IS02=0) N040; Upper limit switch reached
N070 SET REFFRQ=H010; Move to upper limit switch
N075 JMP (IS02=1) N075; Wait for reaching limit switch
N080 SET REFFRQ=H000; Stop axis
N081 SET OS00=1; Axis in upper position
N082 SET OS01=0
N085 JMP N040; Close loop
N100 SET REFFRQ=H011; Start feed quick-jog
N105 SET OS00=0; Axis runs
N109 JMP (M001=0) N040
N110 JMP (IS01=1) N109; Control contact pre-stop
N120 SET REFFRQ=H013; Switch-over to low-jog
N129 JMP (M001=0) N040
N130 JMP (IS03=0) N129; Wait for lower limit switch
N140 SET REFFRQ=H000; Stop axis
N150 JMP (M001=0) N040
N151 SET REFFRQ=H012; Move back to pre-stop
N152 JMP (M001=0) N040
N153 JMP (IS01=0) N152
N154 WAIT H004
N155 JMP N120; Feed
N190 JMP N040

END ;End of program
```

Service

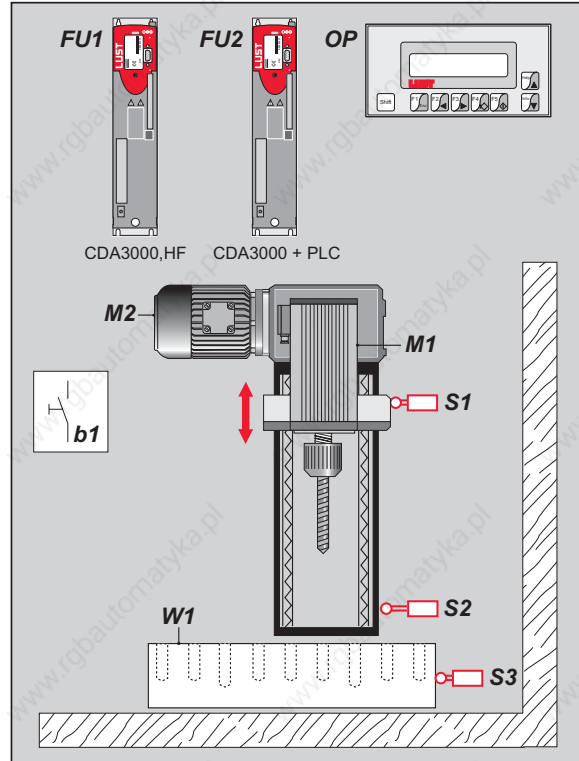
Lust Antriebstechnik offers a lot of information via internet.

Please visit our homepage - <http://www.lust.tec.de> - for further technical information of our products or engineering, or contact your nearest local office.

Software-Update-Service

As a part of our product maintenance function we are continuously improving the quality of the drive systems. Our software-update-service provides you with information on new releases and revisions of the various software versions.

This information, together with the latest firmware, is available for downloading on our info server.

Design-In

An important part for a common success is a professional project management, to keep the time and cost schedule. The earlier your new solution will enter the market the better. We will assist you in:

- the analysis of the requirements
- engineering and design
- working out the specification
- the analysis of the total costs
- the project management

Logistics

We are of course willing to support your logistic concept and it would be a pleasure to coordinate the following with you:

- KANBAN-concept
- KANBAN with control via webcam
- Buffer storage
- Delivery just in time
- Complete shipment of systems
- Commissioning
- Delivery of replacement parts and devices

After Sales

We will assist and support you whenever and wherever it is required. Based on our flexibility, quick reaction times, high technical know-how and a lot of application experience we offer the following services

- Commissioning on site
- Advice and Trainings
- Repair/ Service concept

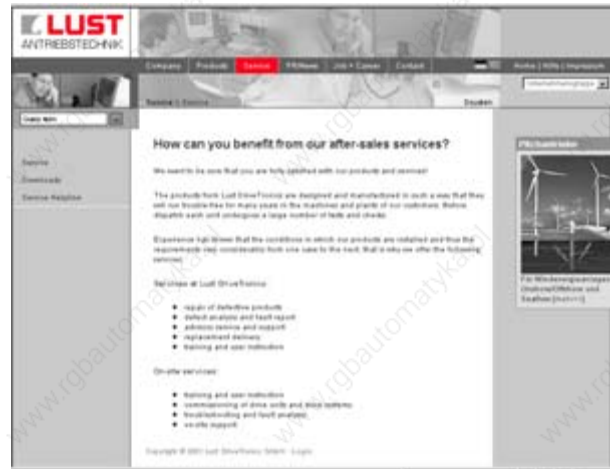

Helpline

The helpline will be glad to support you with:

- commissioning of standard products and systems by phone
- evaluation of error and diagnose indications
- localizing and clearing of reproducible failures and
- software-updates

Availability:

Mo.-Th.: 8 a.m. to 4.30 p.m.

Fr.: 8 a.m. to 4 p.m.

Fon: +49 (0) 6441/966-180

Fax: +49 (0) 6441/966-177

e-mail: helpline@lust-tec.de

Overview inverter modules 0.7 to 132 kW

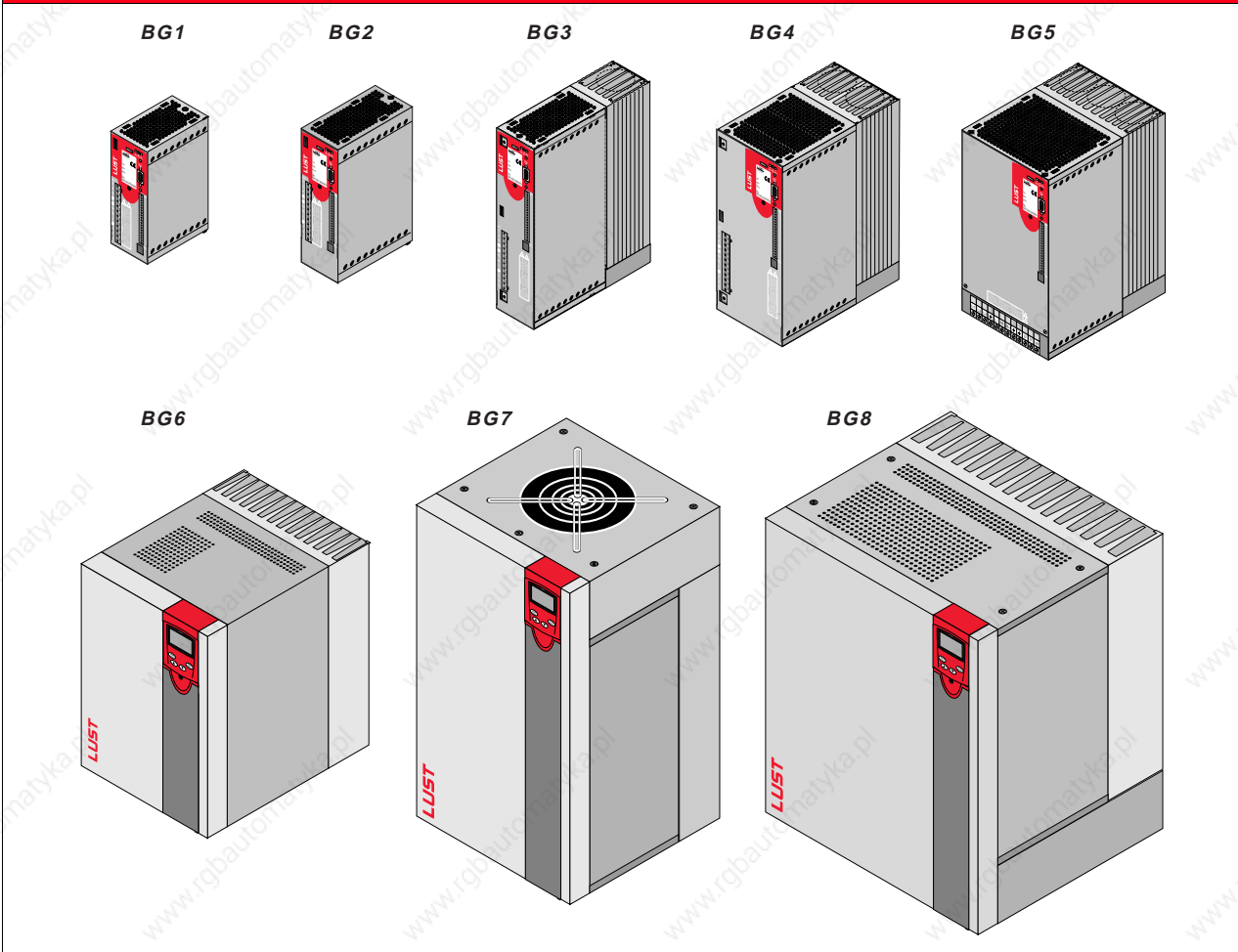

Inverter series CDA3000 size	BG1	BG2	BG2	BG3	BG4	BG5	BG6	BG7	BG8
Inverter power stages	0.75 kW	1.1 kW 1.5 kW	0.75 kW 1.5 kW 2.2 kW	3.0 kW 4.0 kW	5.5 kW 7.5 kW	11 kW 15 kW	22 kW 30 kW 37 kW	45 kW 55 kW	75 kW 90 kW 132 kW
Mains voltage	1 x 208, 230, 240 V			3 x 400, 440, 460 V					
Output current	1.8-fold rated current for 30 s						1.5-fold rated current for 60 s		
Basic-firmware	incl. in standard delivery								
PLC-firmware	Available on CD-ROM, see chapter „accessories for inverter modules“. Software can be load in any inverter module.								
Page	2 - 4	2 - 6	2 - 4 2 - 6	2 - 8	2 - 10	2 - 12	2 - 14	2 - 16	2 - 18

Current capacity of inverter modules

The maximum allowed inverter output current and the peak current are depending on the mains voltage, the motor cable length, the power stage switching frequency and the ambient temperature. A changing of the conditions causes a changing of the maximum allowed current capacity of the inverter modules. Please find the allowed current capacities under changed conditions in the following table, shown as characteristic lines.

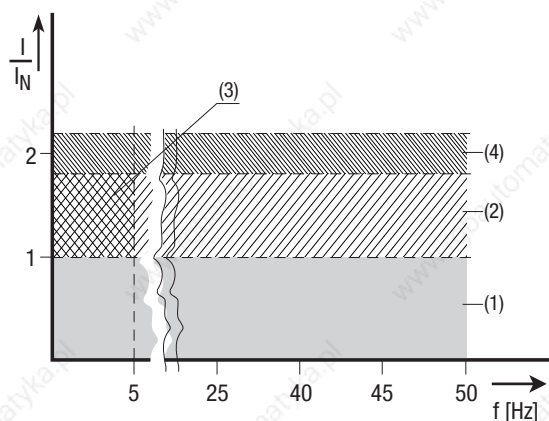

- (1) **Continuous mode**
- (2) **Intermittent mode* > 5 Hz rotating field frequency**
Inverter modules 0,7 to 15 kW
 $I/I_N = 1.8$ for 30 s at 4 kHz
 $I/I_N = 1.8$ for 30 s at 8 kHz
 $I/I_N = 1.8$ for 30 s at 16 kHz
Inverter modules 22 to 132 kW
 $I/I_N = 1.5$ for 60 s at 4 kHz
 $I/I_N = 1.5$ for 60 s at 8 kHz
- (3) **Intermittent mode* 0 to 5 Hz rotating field frequency**
Inverter modules 0,7 to 15 kW
 $I/I_N = 1.8$ für 30 s at 4 kHz
 $I/I_N = 1..25-1.8$ for 30 s at 8 kHz
Inverter modules 22 to 132 kW
 $I/I_N = 1.5$ for 60 s at 4 kHz
 $I/I_N = 1-1.5$ for 60 s at 8 kHz
- (4) **Pulse mode**
Inverter modules 0,7 to 15 kW
 $I/I_N = \text{approx. } 2.2$ at 4, 8, 16 kHz
Inverter modules 22 to 132 kW
 $I/I_N = \text{approx. } 1.8$ at 4, 8 kHz

Features

* Intermittent mode $I_N > I_{eff}$ $I_{eff} = \sqrt{\frac{1}{T} \cdot \sum_{i=1}^n I_i^2 \cdot t_i}$

Inverter modules for 230 V systems:

Inverter module	Rec. 4-pole standard motor [kW]	Switching frequency of power stage [kHz]	Rated current [A]	Peak current for intermittent mode 0 to 5 Hz [A]	Peak current for intermittent mode > 5 Hz [A]
CDA32.004,Cx.x ¹⁾	0.75	4	4	7.2	7.2
		8	4	7.2	7.2
		16	3	5.4	5.4
CDA32.006,Cx.x ¹⁾	1.1	4	5,5	9.9	9.9
		8	5,5	9.9	9.9
		16	4,3	7.7	7.7
CDA32.008,Cx.x ¹⁾	1.5	4	7,1	12.8	12.8
		8	7,1	12.8	12.8
		16	5,5	8	9.9
Peak current for 30 s at inverter modules 0.7 to 15 kW Cooling air temperature 45 °C at power stage switching frequency 4 kHz 40 °C at power stage switching frequency 8, 16 kHz 1) with heat sink HS3... or additional cooling surface			Mains voltage 1 x 230 V -20 % +15 % Motor cable length 10 m Mounting height 1000m above MSL End-to-end mounting		

Inverter modules for 400/460 V systems:

Inverter module	Rec. 4-pole standard motor [kW]	Switching frequency of power stage [kHz]	Rated current I_N [A] at 400 V ²⁾	Rated current I_N [A] at 460 V ³⁾	Peak current for intermittend mode 0 to 5 Hz [A]	Peak current for intermittend mode > 5 Hz [A]
CDA34.003,Cx.x	0.75	4	2.2	2.2	4	4
		8	2.2	2.2	4	4
		16	1.0	1.0	1.1	1.8
CDA34.005,Cx.x ¹⁾	1.5	4	4.1	4.1	7.4	7.4
		8	4.1	3.6	7.4	7.4
		16	2.4	-	4.3	4.3
CDA34.006,Cx.x ¹⁾	2.2	4	5.7	5.7	10.3	10.3
		8	5.7	5.7	10.3	10.3
		16	2.6	-	4.7	4.7
CDA34.008,Wx.x	3.0	4	7.8	7.8	14	14
		8	7.8	7.8	14	14
		16	5	-	7.8	9
CDA34.010,Wx.x	4.0	4	10	10	18	18
		8	10	8.8	16.5	18
		16	6.2	-	7.8	11
CDA34.014,Wx.x	5.5	4	14	14	25	25
		8	14	12.2	21	25
		16	6.6	-	9.2	11.9
CDA34.017,Wx.x	7.5	4	17	17	31	31
		8	17	13.5	21,2	31
		16	8	-	9.2	14.4
CDA34.024,Wx.x	11	4	24	24	43	43
		8	24	24	40	43
		16	15	-	22	27
CDA34.032,Wx.x	15	4	32	32	58	58
		8	32	28	40	58
		16	20	-	22	36
CDA34.045,Wx.x	22	4	45	45	68	68
		8	45	39	54	68
CDA34.060,Wx.x	30	4	60	60	90	90
		8	60	52	71	90
CDA34.072,Wx.x	37	4	72	72	112	112
		8	72	62	78	112
CDA34.090,Wx.x	45	4	90	90	135	135
		8	90	78	104	135
CDA34.110,Wx.x	55	4	110	110	165	165
		8	110	96	110	165
CDA34.143,Wx.x	75	4	143	143	215	215
		8	143	124	143	215
CDA34.170,Wx.x	90	4	170	170	255	255
		8	170	147	212	255
CDA34.250,Wx.x	110	4	210	210	300	300
		132	4	250	250	300

Peak current for 30 s at inverter modules 0.37 to 15 kW

Peak current for 60 s at inverter modules 22 to 132 kW

Cooling air temperature 45 °C at power stage switching frequency 4 kHz (up to CDA34.032)

40 °C at power stage switching frequency 8, 16 kHz (up to CDA34.032)

40 °C at power stage switching frequency 4 kHz (from CDA34.045)

1) with heat sink HS3... or additional cooling surface

2) Mains voltage 3 x 400 V ±10 %

3) Mains voltage 3 x 460 V ±10 %

Motor cable length 10 m

Mounting height 1000m above MSL

End-to-end mounting

Inverter modules up to 0.75 kW (BG1 + 2)



Type CDA-32.004, C1.0

Order code

CDA3 ., x.x, , ...

Technical data

Cooling concept

Version

For complete ordering data please refer to the following tables.

Techn. data	Order code	CDA32.004	CDA34.003
Output, motor side			
Recommended rated power with 4-pole standard motor		0.75 kW	0.75 kW
Device rated power		1.7 kVA	1.6 kVA
Voltage		3 x 0 ... 230 V	3 x 0 ... 400/460 V ¹⁾
Effected rated current (I _N at 4/8 kHz)		4.0 A	2.2 A
Peak current 1,8 x I _N (4/8 kHz) for 30s		7.2 A ²⁾	4.0 A ²⁾
Rotating field frequency		0 ... 400 Hz	
Switching frequency of power stage		4, 8, 16 kHz (factory setting 8 kHz at 40° C cooling air temperature)	
Input, mains side			
Mains voltage		1 x 230 V -20 % +15 %	3 x 460 V -25 % +10 %
Asymmetry of mains voltage		-	±3 % max.
Frequency		50/60 Hz ±10 %	
Power loss 4, 8 (16) kHz		48, 55 W	55, 70 W
Braking chopper power electronics			
Minimum ohmic resistance of an externally installed braking resistor		100 Ω	180 Ω
<p>1) Allowed currents at 460 V are documented on page 2-2 and 2-3</p> <p>2) For further data of currents see page 2-2 and 2-3</p>			

Colling method	CDA32.004, C x.x	CDA34.003, C x.x
Mechanics		
Protection type	IP20	
Cooling air temperature	45 °C (at 4 kHz switching frequency of power stage)	
Weight	1.6 kg	2.3 kg
Mounting		
Single mounting	additional cooling via mounting plate (unvarnished) of 0.3 m ²	
End-to-end mounting of multiple inverter modules	with accessories HS32.1BR	with accessories HS32.200 or HS34.2BR
Dimensions	BG1 [mm]	BG2 [mm]
W (width)	70	70
H (height)	193	218
D (depth)	120	145
A	50	50
C	205	230
E	215	240
D \emptyset	\emptyset 4.8	\emptyset 4.8
Dimensional drawings		



Note: For appropriated heat sinks see page 3-9.



Type CDA-34.004, C1.0

Order code

CDA3 ., x.x, , ...

Technical data

Cooling method

Version

For complete ordering data please refer to the following tables.

Order code	CDA32.006	CDA32.008	CDA34.005	CDA34.006
Techn. data				
Output motor side				
Recommended rated power with 4-pole standard motor	1.1 kW	1.5 kW	1.5 kW	2.2 kW
Device rated power	2.3 kVA	3.0 kVA	3.0 kVA	4.2 kVA
Voltage	3 x 0 ... 230 V	3 x 0 ... 230 V	3 x 0 ... 400/460 V ¹⁾	3 x 0 ... 400/460 V ¹⁾
Effective rated current (I _N at 4/8 kHz)	5.5 A	7.1 A	4.1 A	5.7 A
Peak current 1,8 x I _N (4,8 kHz) for 30s	9.9 A ²⁾	12.8 A ²⁾	7.4 A ²⁾	10.3 A ²⁾
Rotating field frequency	0 ... 400 Hz			
Switching frequency of power stage	4, 8, 16 kHz (factory setting 8 kHz at 40 °C cooling air temperature)			
Input mains side				
Mains voltage	1 x 230 V -20 % +15 %	1 x 230 V -20 % +15 %	3 x 460 V -25 % +10 %	3 x 460 V -25 % +10 %
Asymmetry of mains voltage	-	-	±3 % max.	
Frequency	50/60 Hz ±10 %			
Power loss 4, 8 (16) kHz	75/ 82 W	95/ 105 W	80/ 112 W	106/ 148 W
Braking chopper power electronics				
Peak braking power with internal braking resistor (only version CDA34 ..., Wx.x, BR)	-	-	-	1,6 kW at 360 Ω
Minimum ohmic resistance of an externally installed braking resistor	56 Ω	56 Ω	180 Ω	180 Ω
<p>1) Allowed currents at 460 V are documented on page 2-2 and 2-.</p> <p>2) For further data of currents see page 2-2 and 2-3.</p>				

Cooling method	CDA32.006, C x.x	CDA32.008, C x.x	CDA34.005, C x.x	Drawing
Mechanics				
Protection type	IP20			
Cooling air temperature	45°C (at 4kHz switching frequency of power stage)			
Weight	2.3 kg			
Mounting				
Single mounting	additional cooling via switching cabinet mounting plate (unvarnished) of 0.3 m ²			
End-to-end mounting of multiple inverter modules	only with accessories HS32.200 or HS32.2BR	only with accessories HS32.200 / HS34.2BR		
Dimensions	BG2 [mm]			
W (width)	70			
H (height)	218			
D (depth)	145			
A	50			
C	230			
E	240			
D	∅ 4.8			
				vertical mounting, Cold Plate

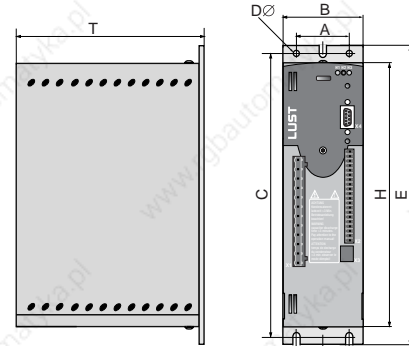

Cooling method	CDA34.006, W x.x	Drawing
Mechanics		
Protection type	IP20	
Cooling air temperature	45°C (at 4kHz switching frequency of power stage)	
Weight	3.5 kg	
Dimensions	BG2[mm]	
W (width)	70	
H (height)	240	
D (depth)	220	
A	40	
C	260	
E	270	
D	∅ 4.8	
		vertical mounting, Cold Plate

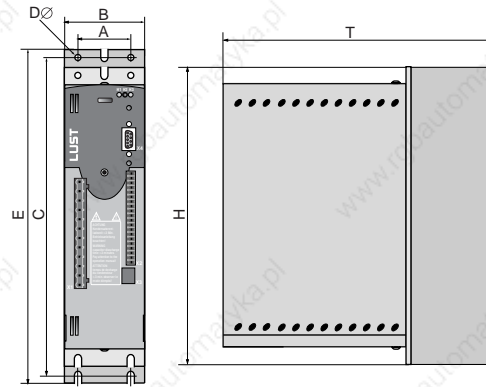

Version	Characteristics
CDA34.006, Wx.x, BR	Internal braking resistor



Note: For appropriate heat sinks see page 3-9.



Type CDA-34.008, W1.0

Order code

CDA3 ., x.x, , ...

Technical Data

Cooling method

Version

For complete ordering data please refer to the following tables.

Order code	CDA34.008	CDA34.010
Techn. data		
Output motor side		
Recommended rated power with 4-pole standard motor	3.0 kW	4.0 kW
Device rated power (400V)	5.7 kVA	7.3 kVA
Voltage	3 x 0 ... 400/460 V ¹⁾	
Effective rated current (I _N at 4/8 kHz)	7.8 A	10 A
Peak current 1,8 x I _N (4 kHz) for 30 s	14 A ²⁾	18 A ²⁾
Rotating field frequency	0 ... 400 Hz	
Switching frequency of power stage	4, 8, 16 kHz (factory setting 8 kHz at 40 °C cooling air temperature)	
Input mains side		
Mains voltage	3 x 460 V -25 % +10 %	3 x 460 V -25 % +10 %
Asymmetry	±3 % max.	
Frequency	50/60 Hz ±10 %	
Power loss 4, 8 (16) kHz	135/ 162 W	172/ 207 W
Braking chopper power electronics		
Peak braking power with internal braking resistor (only version CDA34 ..., Wx.x, BR)	6.0 kW at 90 Ω	6.0 kW at 90 Ω
Minimum ohmic resistance of an externally installed braking resistor	81 Ω	81 Ω
<p>1) Allowed currents at 460 V are documented on page 2-2 and 2-3</p> <p>2) For further data of currents see page 2-2 and 2-3</p>		

	CDA34 ..., W x.x	CDA34 ..., C x.x	CDA34 ..., D x.x
Cooling method	Wall mounting	Cold Plate	Push-through heat sink
Mounting method	vertical mounting, unhindered air flow	vertical mounting on mounting plate or cooling profile section	vertical mounting, heat sink pushed through mounting plate
Protection kind	IP20	IP20	IP20 (device) IP54 (heat sink size)
Cooling air temp.	45°C (at 4 kHz switching frequency of power stage)		
Weight	4.4 kg	3.2 kg	4.6 kg
Maße	BG3 [mm]	BG3 [mm]	BG3 [mm]
W (width)	70	70 (100)	70 (110)
H (height)	300	300	300
D (depth)	218	150	T1 138, T2 80
A	40	85	90
C	320	200	320
D	∅ 4.8	∅ 5.5	∅ 4.8
E	330	--	340
F	--	100	200

Drawings

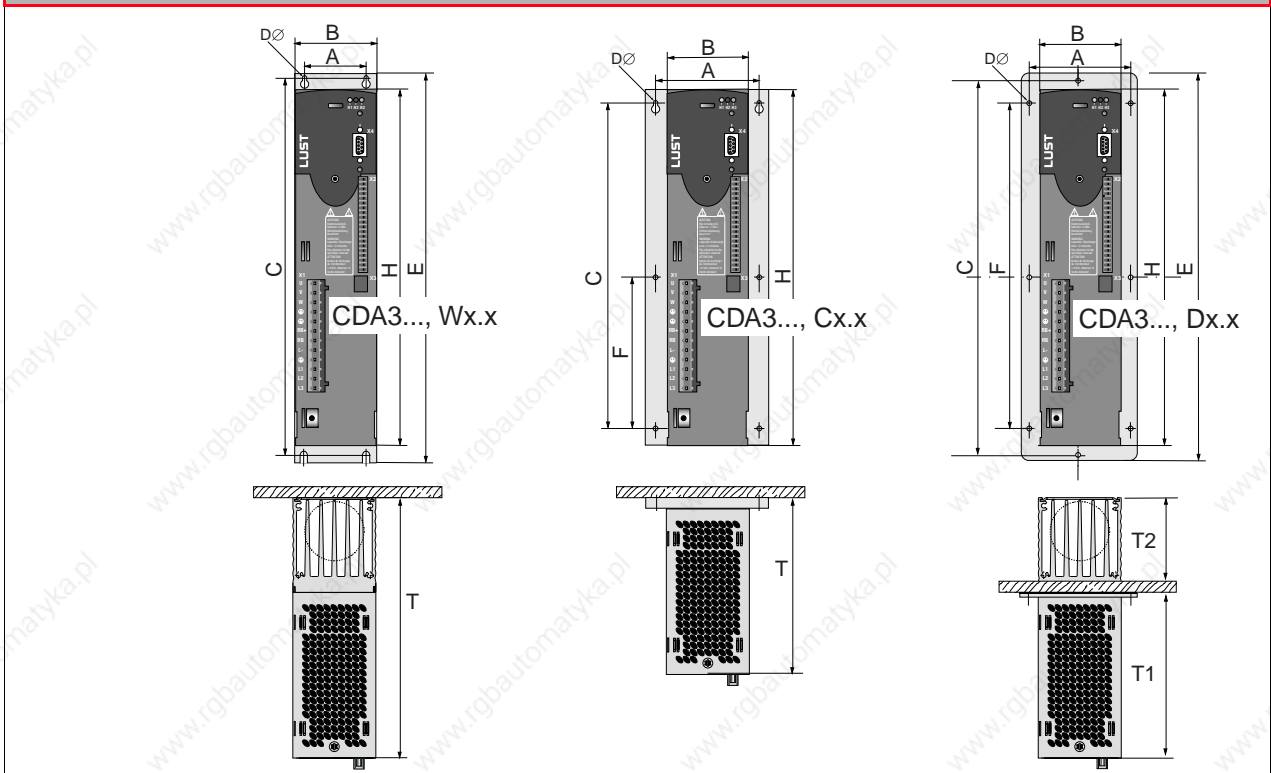

Version	Characteristics
CDA34.xxx, BR	Internal braking resistor only for devices with cooling method CDA34 ..., W x.x or CDA34 ..., D x.x



Note: Please note that for the cold plate and push-through heat sink cooling methods special conditions regarding the dissipation of power loss must be met. For more details see CDA3000 operation manual.



Type CDA-34.014, W1.0

Order code

CDA3 . , x.x, , ...

Technical Data

Cooling method

Version

For complete ordering data please refer to the following tables.

Order code	CDA34.014	CDA34.017
Techn. data		
Output motor side		
Recommended rated power with 4-pole standard motor	5.5 kW	7.5 kW
Device rated power (400V)	10.2 kVA	12.4 kVA
Voltage	3 x 0 ... 400/460V ¹⁾	
Effective rated current (I_N at 4/8 kHz)	14 A	17 A
Peak current $1,8 \times I_N$ (4 kHz) for 30 s	25 A ²⁾	31 A ²⁾
Rotating field frequency	0 ... 400 Hz	
Switching frequency of power stage	4, 8, 16kHz (factory setting 8 kHz at 40 °C cooling air temperature)	
Input mains side		
Mains voltage	3 x 460 V -25 % +10 %	3 x 460 V -25 % +10 %
Asymmetry	±3 % max.	
Frequency	50/60Hz ±10%	
Power loss 4, 8 (16) kHz	210, 268 W	255, 325 W
Braking chopper power electronics		
Peak braking power with internal braking resistor (only version CDA34 ..., Wx.x, BR)	6.0 kW at 90 Ω	6.0 kW at 90 Ω
Minimum ohmic resistance of an externally installed braking resistor	47 Ω	47 Ω
<p>1) Allowed currents at 460 V are documented on page 2-2 and 2-3.</p> <p>2) For further data of currents see page 2-2 and 2-3.</p>		

	CDA3..., <u>W</u> x.x	CDA3..., <u>C</u> x.x	CDA3..., <u>D</u> x.x
Cooling method	Wall mounting	Cold Plate	Push-through heat sink
Mounting method	vertical mounting, unhindered air flow	vertical mounting on mounting plate or cooling profile section	vertical mounting, heat sink pushed through mounting plate
Protection kind	IP20	IP20	IP20 (device) IP54 (heat sink side)
Cooling air temp.	45°C (at 4 kHz switching frequency of power stage)		
Weight	6.5 kg	5.2 kg	6.7 kg
Dimensions	BG4 [mm]	BG4 [mm]	BG4 [mm]
W (width)	120	120 (150)	120 (160)
H (height)	300	300	300
D (depth)	218	150	T1 138, T2 80
A	80	135	A 140 , A1 80
C	320	200	320
D	∅ 4.8	∅ 5.5	∅ 4.8
E	330	--	340
F	--	100	200

Drawings

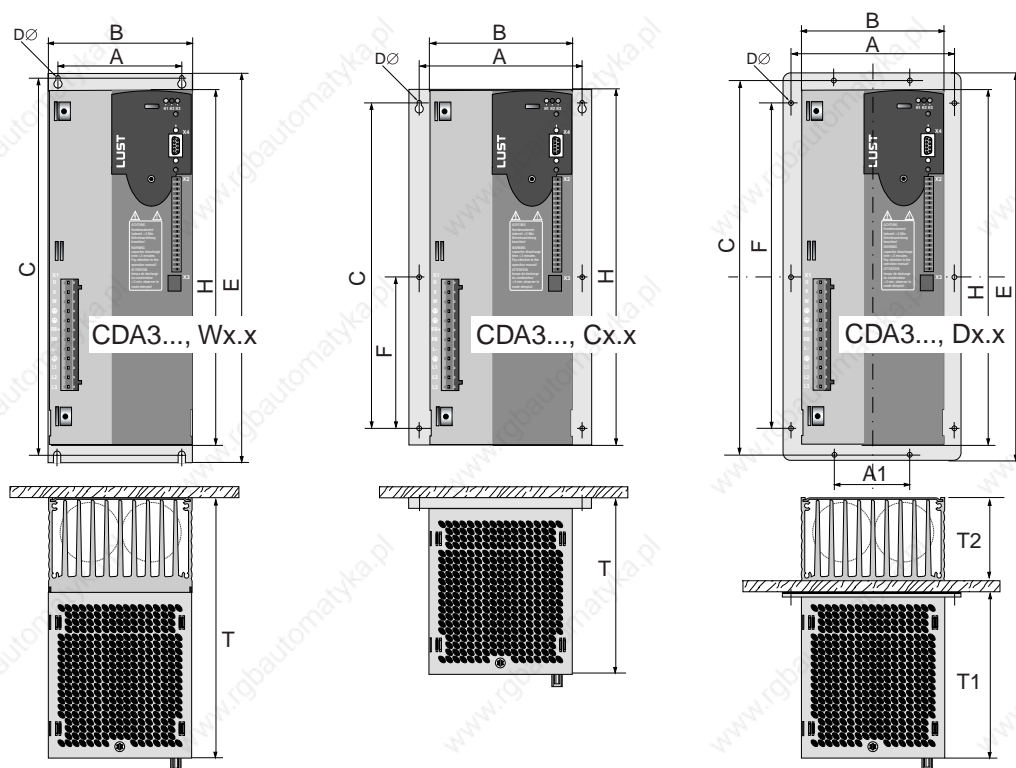

Version	Characteristics
CDA34.xxx, <u>BR</u>	Internal braking resistor only for devices with cooling method CDA34, Wx.x or CDA34, Dx.x

Note:

Please note that for the cold plate and push-through heat sink cooling methods special conditions regarding the dissipation of power loss must be met. For more details see CDA3000 operation manual.

Inverter module 11 and 15 kW (BG5)

Type CDA-34.024, C1.0

Order code

 CDA3 ., x.x, , ...
Technical Data
Cooling method
Version

For complete ordering data please refer to the following tables.

Order code	CDA34.024	CDA34.032
Techn. data		
Output motor side		
Recommended rated power with 4-pole standard motor	11 kW	15 kW
Device rated power (400V)	17.5 kVA	23.3 kVA
Voltage	3 x 0 ... 400/460 V ¹⁾	
Effective rated current (I_N at 4/8 kHz)	24 A	32 A
Peak current 1,8 x I_N (4 kHz) for 30 s	43 A ²⁾	58 A ²⁾
Rotating field frequency	0 ... 400 Hz	
Switching frequency of power stage	4, 8, 16 kHz (factory setting 8 kHz at 40 °C cooling air temperature)	
Input mains side		
Mains voltage	3 x 460 V -25 % +10 %	3 x 460 V -25 % +10 %
Asymmetry	±3 % max.	
Frequency	50/60 Hz ±10 %	
Power loss 4, 8 (16) kHz	315/ 400 W	400/ 510 W
Braking chopper power electronics		
Peak braking power with internal braking resistor (only version CDA34 ..., Wx.x, BR)	6.0 kW at 90 Ω	6.0 kW at 90 Ω
Minimum ohmic resistance of an externally installed braking resistor	22 Ω	22 Ω
1) Allowed currents at 460 V are documented on page 2-2 and 2-3. 2) For further data of currents see page 2-2 and 2-3.		

	CDA3 ..., <u>W</u> x.x	CDA3 ..., <u>C</u> x.x	CDA3 ..., <u>D</u> x.x
Cooling method	Wall mounting	Cold Plate	Push-through heat sink
Mounting method	vertical mounting, unhindered air flow	vertical mounting on mounting plate or cooling profile section	vertical mounting, heat sink pushed through mounting plate
Protection kind	IP20	IP20	IP20 (device) IP54 (heat sink side)
Cooling air temp.	45°C (at 4 kHz switching frequency of power stage)		
Weight	7.2 kg	6.4 kg	7.4 kg
Dimensions	BG5 [mm]	BG5 [mm]	BG5 [mm]
W (width)	170	170 (200)	170 (210)
H (height)	300	300	300
D (depth)	218	150	T1 138, T2 135
A	130	185	A 190 , A1 100
C	320	200	320
D	∅ 4.8	∅ 5.5	∅ 4.8
E	330	--	340
F	--	100	200

Drawings

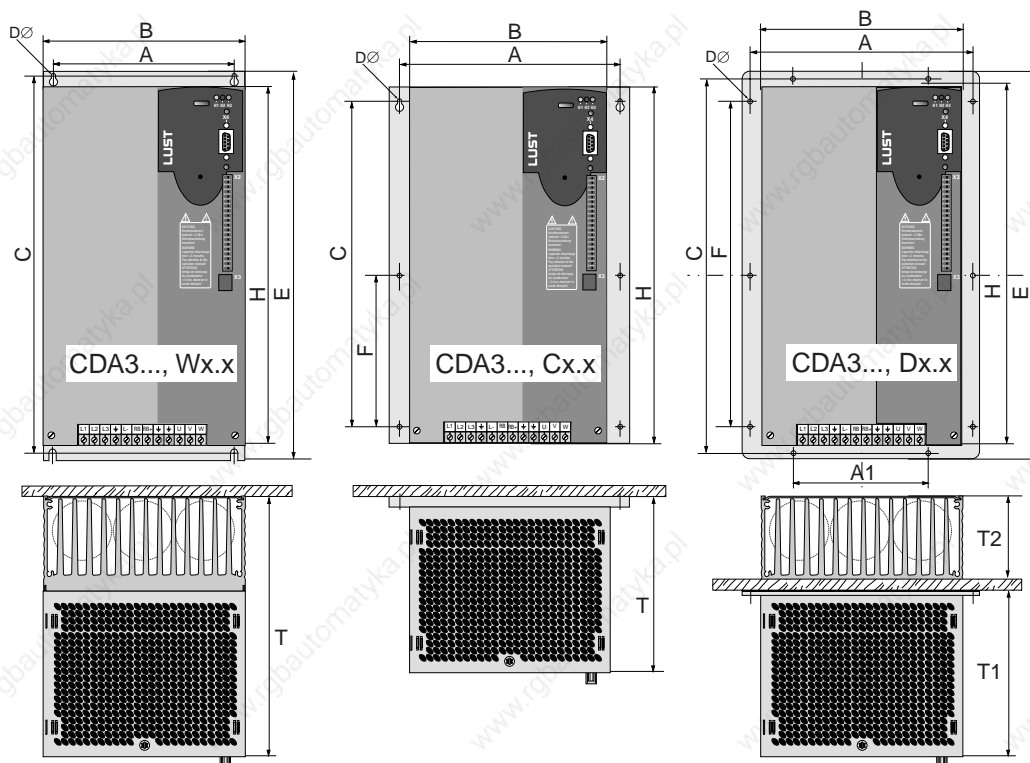

Version	Characteristics
CDA34.xxx, <u>BR</u>	Internal braking resistor only for devices with cooling method CDA34 ..., <u>W</u> x.x or CDA34 ..., <u>D</u> x.x



Note: Please note that for the cold plate and push-through heat sink cooling methods special conditions regarding the dissipation of power loss must be met. For more details see CDA3000 operation manual.

Inverter module 22, 30 and 37 kW (BG6)

Type CDA-34.045, W1.0

Order code

 CDA3 ., x.x, , ...
Technical Data
Cooling method
Version

For complete ordering data please refer to the following tables.

Order code			
Techn. data	CDA34.045	CDA34.060³⁾	CDA34.072³⁾
Output motor side			
Recommended rated power with 4-pole standard motor	22 kW	30 kW	37 kW
Device rated power (400V)	32.8 kVA	43.8 kVA	52.5 kVA
Voltage	3 x 0 ... 400/460 V ¹⁾		
Effective rated current (I_N at 4/8 kHz)	45 A	60 A	72 A
Peak current $1,8 \times I_N$ (4 kHz) for 30 s	68 A ²⁾	90 A ²⁾	108 A ²⁾
Rotating field frequency	0 ... 200 Hz		
Switching frequency of power stage	4, 8 kHz (factory setting 4 kHz)		
Input mains side			
Mains voltage	3 x 460 V -25 % +10 %	3 x 460 V -25 % +10 %	3 x 460 V -25 % +10 %
Asymmetry	±3 % max.		
Frequency	50/60 Hz ±10 %		
Power loss 4, 8 (16) kHz	777/ 933 W	1010/ 1220 W	1270/ 1530 W
Braking chopper power electronics			
Peak braking power with internal braking resistor (only version CDA34 ..., Wx.x, BR)	18 Ω	18 Ω	13 Ω
1) Allowed currents at 460 V are documented on page 2-2 and 2-3 2) For further data of currents see page 2-2 and 2-3 3) Inverter modules have to be operated with line chokes, see chapter „ supplementary components“			

	CDA3..., W x.x
Cooling method	Wall mounting
Mounting method	vertical mounting, unhindered air flow
Protection kind	IP20
Cooling air temperature	45°C (at 4 kHz switching frequency of power stage)
Weight	20 kg
Dimensions	BG6 [mm]
W (width)	250
H (height)	345
D (depth)	325
A	215
C	360
D	∅ 6.0
E	375

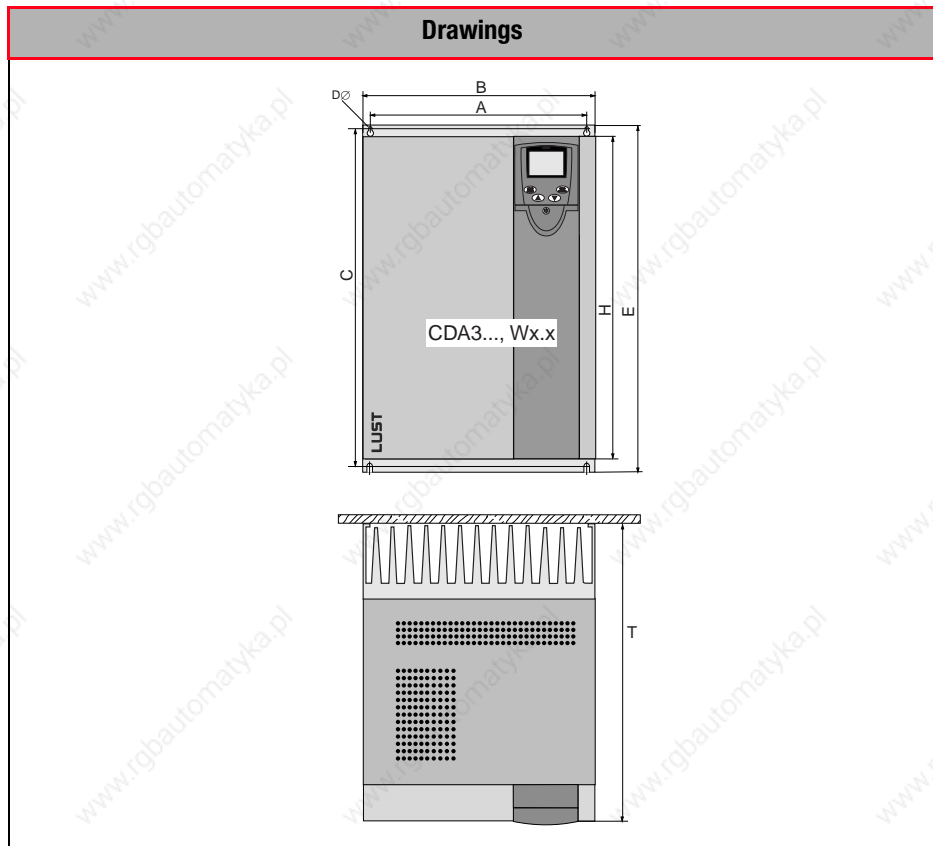

Note: Please note that for the cold plate and push-through heat sink cooling methods special conditions regarding the dissipation of power loss must be met. For more details see CDA3000 operation manual.

Inverter module 45 and 55 kW (BG7)

Type CDA-34.090, W1.0

Order code

 CDA3 . , x.x, , ...
Technical Data
Cooling method
Version

For complete ordering data please refer to the following tables.

Order code	CDA34.090 ³⁾	CDA34.110 ³⁾
Techn. data		
Output motor side		
Recommended rated power with 4-pole standard motor	45 kW	55 kW
Device rated power (400V)	65.6 kVA	80 kVA
Voltage	3 x 0 ... 400/460 V ¹⁾	
Effective rated current (I_N at 4/8 kHz)	90 A	110 A
Peak current 1,8 x I_N (4 kHz) for 30 s	135 A ²⁾	165 A ²⁾
Rotating field frequency	0 ... 200 Hz	
Switching frequency of power stage	4, 8 kHz (factory setting 4 kHz)	
Input mains side		
Mains voltage	3 x 460 V -25 % +10 %	3 x 460 V -25 % +10 %
Asymmetry	±3 % max.	
Frequency	50/60 Hz ±10 %	
Power loss 4, 8 (16) kHz	1510/ 1820 W	1890/ 2290 W
Braking chopper power electronics		
Peak braking power with internal braking resistor (only version CDA34 ..., Wx.x, BR)	12 Ω	10 Ω
1) Allowed currents at 460 V are documented on page 2-2 and 2-3. 2) For further data of currents see page 2-2 and 2-3. 3) Inverter modules have to be operated with line chokes, see chapter „ supplementary components“.		

	CDA34 ..., W x.x
Cooling method	Wall mounting
Mounting method	vertical mounting, unhindered air flow
Protection kind	IP20
Cooling air temperature	45°C (at 4 kHz switching frequency of power stage)
Weight	31 kg
Dimensions	BG7 [mm]
W (width)	300
H (height)	550
D (depth)	305
A	265
C	555
D	∅ 9
E	600

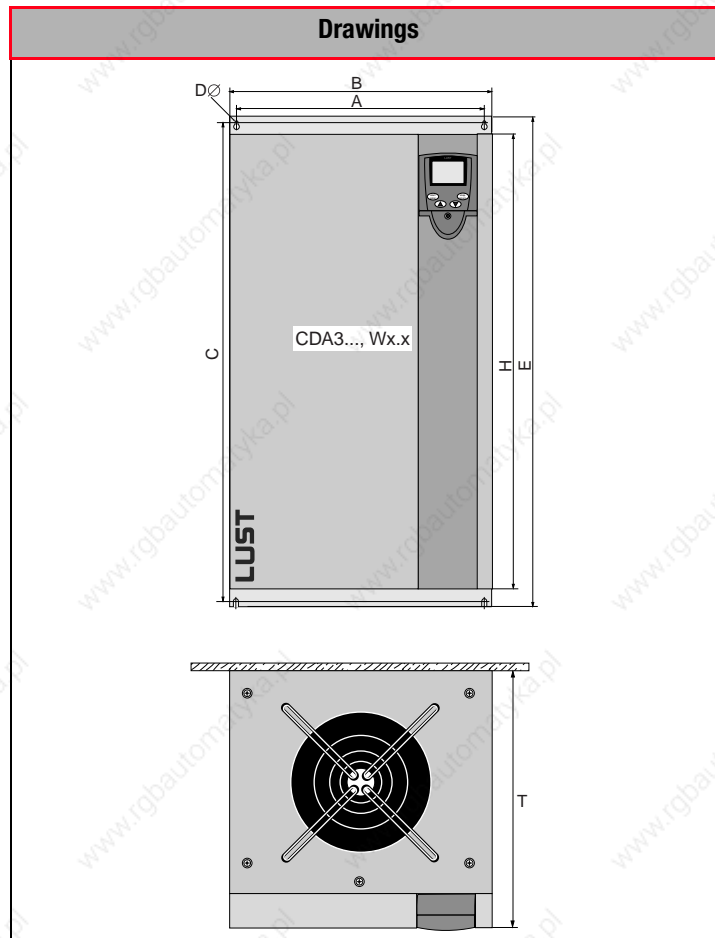

Inverter module 75 to 132 kW (BG8)

Type CDA-34.170, W1.0

Order code

 CDA3 , x.x , , ...
Technical Data
Cooling method
Version

For complete ordering data please refer to the following tables.

Order code	CDA34.143, Wx.x ³⁾	CDA34.170, Wx.x ³⁾	CDA34.250, Wx.x ³⁾
Techn. data			
Output motor side			
Recommended rated power with 4-pole standard motor	75 kW	90 kW	110/132 kW
Device rated power (400V)	104 kVA	124 kVA	145/173 kVA
Voltage	3 x 0 ... 400/460 V ¹⁾		
Effective rated current (I_N at 4/8 kHz)	143 A	170 A	210/250 A
Peak current $1,8 \times I_N$ (4 kHz) for 30 s	214 A ²⁾	255 A ²⁾	300 A ²⁾
Rotating field frequency	0 ... 200 Hz		
Switching frequency of power stage	4 kHz (factory setting 4 kHz)		
Input mains side			
Mains voltage	3 x 460 V -25 % +10 %		
Asymmetry	±3 % max.		
Frequency	50/60 Hz ±10 %		
Power loss 4, 8 (16) kHz	2450 W 2970 W	2930W 3550 W	3405/ 4043 W -
Braking chopper power electronics			
Peak braking power with internal braking resistor (only version CDA34 ..., Wx.x, BR)	5.6 Ω	5.6 Ω	5.6 Ω
1) Allowed currents at 460 V are documented on page 2-2 and 2-3. 2) For further data of currents see page 2-2 and 2-3. 3) Inverter modules have to be operated with line chokes, see chapter „ supplementary components“.			

	CDA34 ..., W x.x
Cooling method	Wall mounting
Mounting method	vertical mounting, unhindered air flow
Protection kind	IP20
Cooling air temperature	40°C
Weight	60 kg
Dimensions	BG8 [mm]
W (width)	412
H (height)	500
D (depth)	370
A	340
C	485
D	∅ 9
E	510

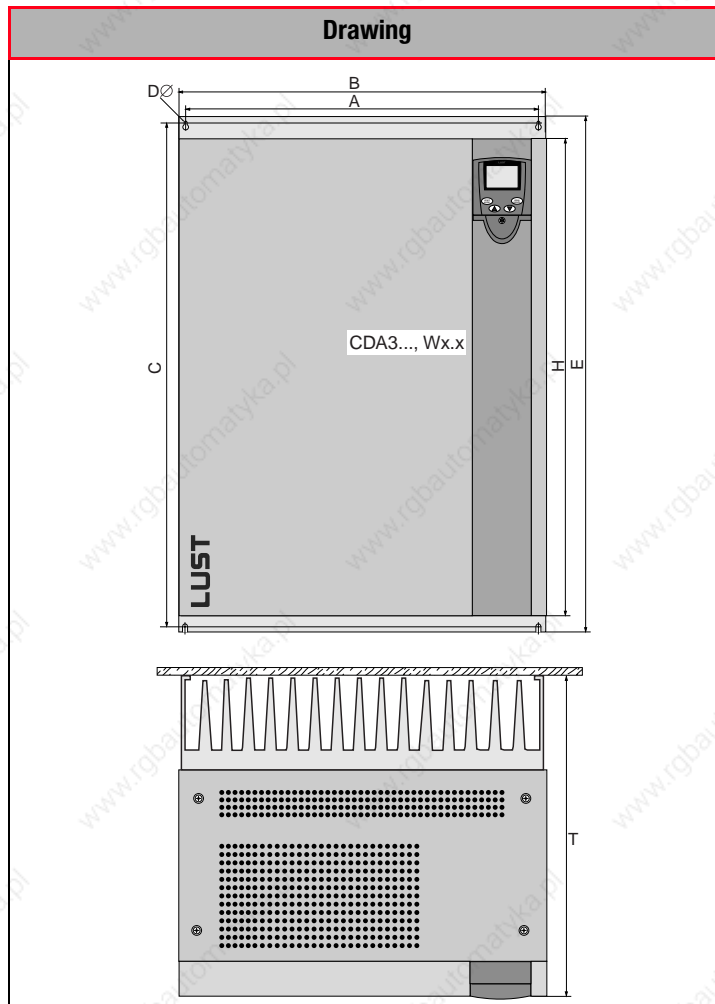

Overview of accessories for inverter module

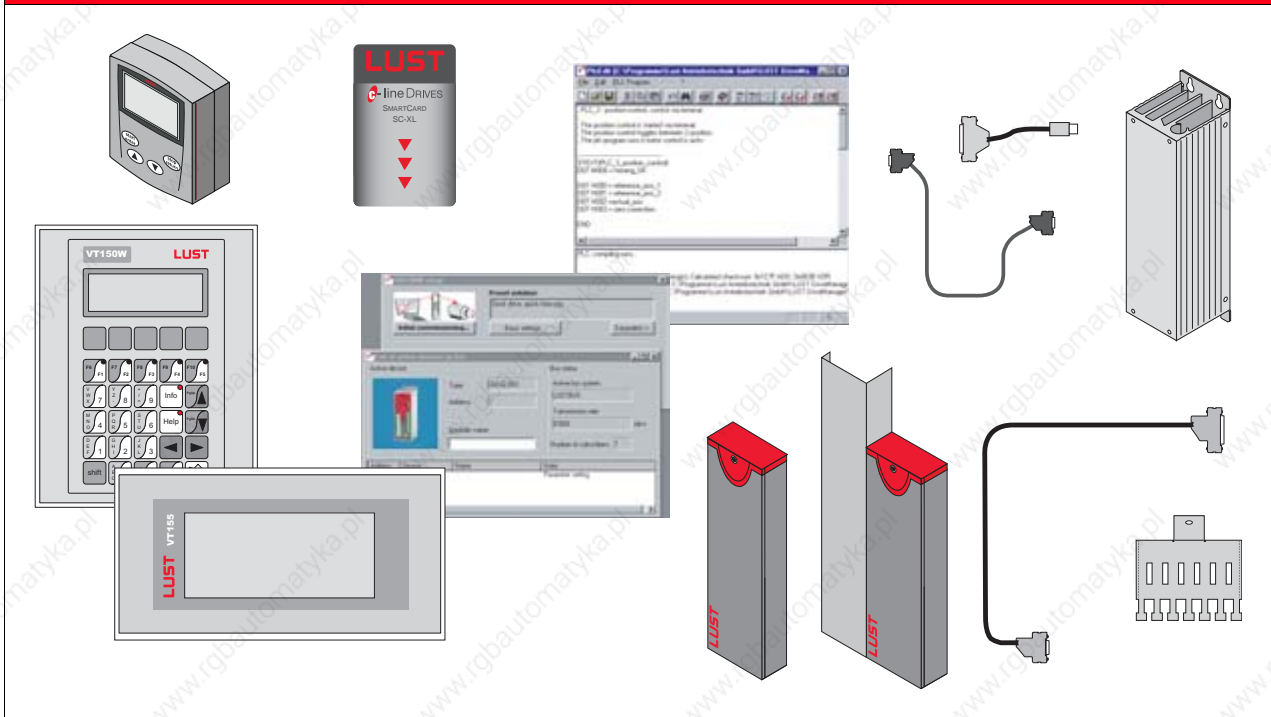

Accessory	Operator module	Memory card	Operator Panels	PLC-Programming	User software	Connecting cable	Terminal cover
Type	KP100 KP200 KP200-XL	SC SC-XL	VT050 VT150W VT155W VT505W	PLCEditor	DRIVEMANAGER	CCD-SUB90X	TB1 ... TB5
Page	3 - 2	3 - 3	3 - 4	3 - 10	3 - 11	3 - 12	3 - 13

Accessory	EMV-shield connection	Heat sink for BG1 + 2
Type	ST02 ... ST05 SMC50 SMB50	HS32.1BR HS32.200 HS32.2BR HS34.2BR
Page	3 - 14	3 - 16

System selection

Invertermodule

Accessories for Invertermodule

User- und Communicationmodule

Supplementary Componentes



KP200

KP200-XL (Symbolic graph)

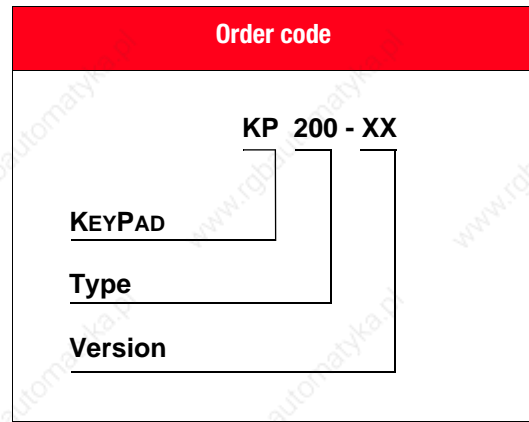

Order code	Short explanation
KP100 (w/o picture)	KEYPAD for parameter setting, actual value indication and serial commissioning of ED1200 inverter. The KEYPAD supports the SMARTCARD „SC“.
KP200	KEYPAD for parameter setting, actual value indication and serial commissioning of inverter modules with firmware: „Basis and HF“. The KEYPAD supports the SMARTCARD „SC“.
KP200-XL	KEYPAD for parameter setting, actual value indication and serial commissioning of inverter modules with firmware: „Basis, HF and PLC“. The KEYPAD supports the SMARTCARD „SC-XL“.

Mechanic KP100 (w/o picture)	
Dimension	62 x 158 x 21 mm (W x H x D)
Weight	170 g

Mechanic KP200 und KP200-XL	
Dimension (see picture)	70 x 73 x 33 mm (W x H x D)
Weight	150 g
Connection (RS232)	
Standard (6)	can be plugged directly into inverter module

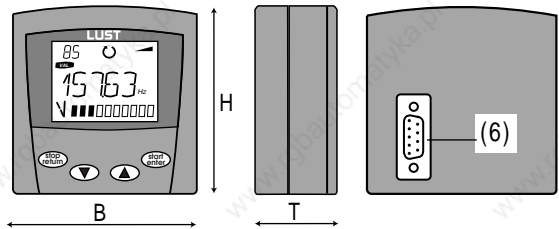

Cable connection	Installation in switching cabinet door
Connection between KP200/ KP200-XL and inverter module CDA3000 via cable CCD-SUB90X	<p>Mounting in the cabinet door requires two holes for the fixing screws and a break-through for the connector.</p> <p>Please use only self-tapping screws for thermoplastics (e.g. EJOT PT screw, Type K30 x 8 WN1412).</p>

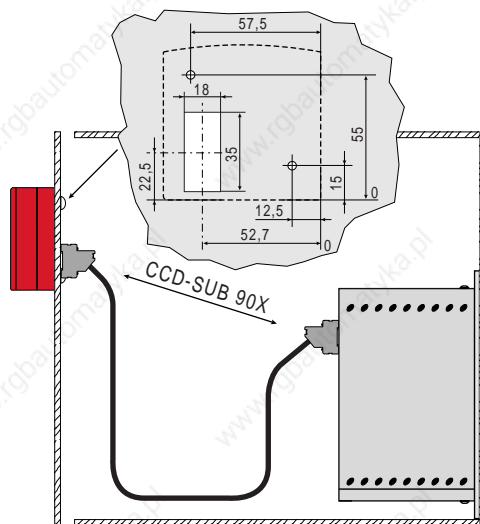

SMARTCARD

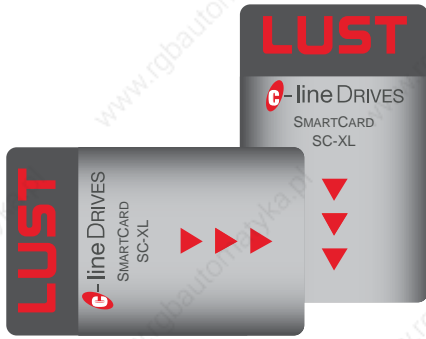

Order code

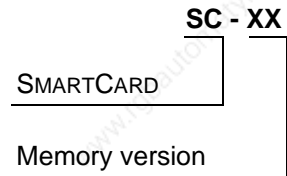

Order code	Short explanation
SC	Data of inverter modules can be saved and transferred to further inverter modules without problems. Suitable for KP100 and KP200.
SC-XL	Data set of inverter modules with firmware „PLC“ can be saved and transferred to further inverter modules without problems. Suitable for KP200-XL.

System layout	Explanation
	<ol style="list-style-type: none"> (1) Connection X4 for operating modules or PC-connection (RS232 interface) (2) Chip card SC/ SC-XL (3) Operator module KP200/ KP200-XL (4) PC with user software DRIVEMANAGER

Operator Panels with text-display



VT050



VT150W

Order code	VT050	VT150W
Technical data		
Voltage supply	24 VDC (18 - 32 VDC)	
Power consumption at 24 VDC	5 W	15 W
Protection fuse	315 mA (Fine protection Type F)	800 mA (Fine protection Type F)
Protection kind	IP65 (Front side)	
Operating, storage and transport temperature	0 ... +50° C / -20° ... +60° C	
Humidity	0 ... 85%	
Certification/Conformity	CE, NEMA12	
Dimension (outer) W x H x D [mm]	166 x 86 x 41	148 x 188 x 41
Mounting frame W x H [mm]	157 x 77	123 x 175
Weight	0.5 kg	0.7 kg

Article code of panel:	Characteristics of panels:	Characteristics of panels:
	VT050 000 00N	VT150W 000 00N
	VT050 000 CNN	VT150W 000 CNN

Display					
Type	Text LCD	●	●	Text LCD	● ●
Background lighting	LED	●	●	LED	● ●
Lines x characters	2 x 20	●	●	4 x 20	● ●
Representational format [mm]	73.5 x 11.5	●	●	70.4 x 20.8	● ●
Character matrix in text mode [Pixel]	5 x 7	●	●	5 x 7	● ●
Size of characters [mm]	3.2 x 5.5	●	●	2.95 x 4.75	● ●
Contrast adjustment	Trim Pot	●	●	Trim Pot	● ●
Character sets	ASCII, Katakana	●	●	ASCII, Katakana	● ●
Keyboard					
System-/ function-/alphanumeric keys	8 / 5 / -	●	●	9 / 5 / 11	● ●
LEDs for function-/operating keys	-	●	●	5 / 2	● ●

Article code of panel:	Characteristics of panels:		Characteristics of panels:	
	VT050 000 00N		VT150W 000 00N	
	VT050 000 CNN		VT150W 000 CNN	
User memory				
Project (Flash EPROM) [kB]	256 kB	• •	256 kB	• •
Interfaces				
Serial port MSP, 25 pin female	RS232	• •	RS232	• •
Serial port ASP-8, pin female (only for programming)	RS232	•	RS232	•
Networks				
Integrated	CAN _{open}	•	CAN _{open}	•
Characteristics				
Project languages	4	• •	6	• •
Password level /Bit password	- / 8 bit	• •	10/ 8 bit	• •
Pages/Variables per page	127 / 8	• •	1024 / 30	• •
Variable format	DEC, HEX, BIN, BCD, ASCII, Floating Point	• •	DEC, HEX, BIN, BCD, ASCII, Floating Point	• •
Dynamic texts	Depending on size of project memory	• •	Depending on size of project memory	• •
ISA-Alarms/Information messages	- / 128	• •	- / 1024	• •
Message help (page/information message/alarms)	127/128/-	• •	1024/1024/-	• •
Automatic operations	16	• •	16	• •
Timer /time basis 100 ms)	16	• •	16	• •
Equations	32	• •	32	• •

Dimensions	VT050	VT150W
W (Width)	166 mm	148 mm
H (Height)	86 mm	188 mm
D (Depth)	41 mm	41 mm
Mounting frame A (Height)	77 mm	175 mm
Mounting frame C (Width)	157 mm	123 mm
D	4 mm	4,5 mm
E	27 mm	110 mm
Drawing		

Article code of panel:	Characteristics of panels:	Characteristics of panels:
	VT155 000 00N	VT505W 000 00N
	VT155 000 CNN	VT505W 000 CNN

Networks

Integrated	CAN _{open}			CAN _{open}		
		•			•	

Characteristics

	VT155			VT505W		
Project languages	4	•	•	4	•	•
Password level/Bit-password	10/ 8 bit	•	•	10/ 8 bit	•	•
Pages/Variables per page	64/ 32	•	•	128/ 34	•	•
Variable format	DEC, HEX, BIN, BCD, ASCII, Floating Point	•	•	DEC, HEX, BIN, BCD, ASCII, Floating Point	•	•
Dynamic texts/ picture index	depending on size of project memory	•	•	depending on size of project memory	•	•
ISA-Alarms/Information messages	256 / 256	•	•	- / 256	•	•
Message help (page/information message/ alarm)	64/256/256	•	•	128/256/-	•	•
Alarm buffer	220	•	•	-	•	•
Macros (Total, commands per Macro)	1024/16	•	•	1024/16	•	•
Printed pages (Total/ Fields per page)	64/128	•	•	-	•	•
Automatic operations	16	•	•	16	•	•
Timer (time basis 100 ms)	16	•	•	16	•	•
Equations	32	•	•	32	•	•
Bar graphs per page	32	•	•	34	•	•
Buttons per page	24	•	•	24	•	•
Hardware clock	with condensator	•	•	-	•	•

Dimensions	VT155W	VT505W
W (Width)	166 mm	210 mm
H (Height)	100 mm	158 mm
D (Depth)	39,6 mm	54 mm
Mounting frame A (Height)	91 mm	148 mm
Mounting frame C (Width)	157 mm	198 mm
Mounting frame high A1	157 mm	-
Mounting frame high C1	91 mm	-
D	4 mm	6 mm
E	102 mm	86 mm

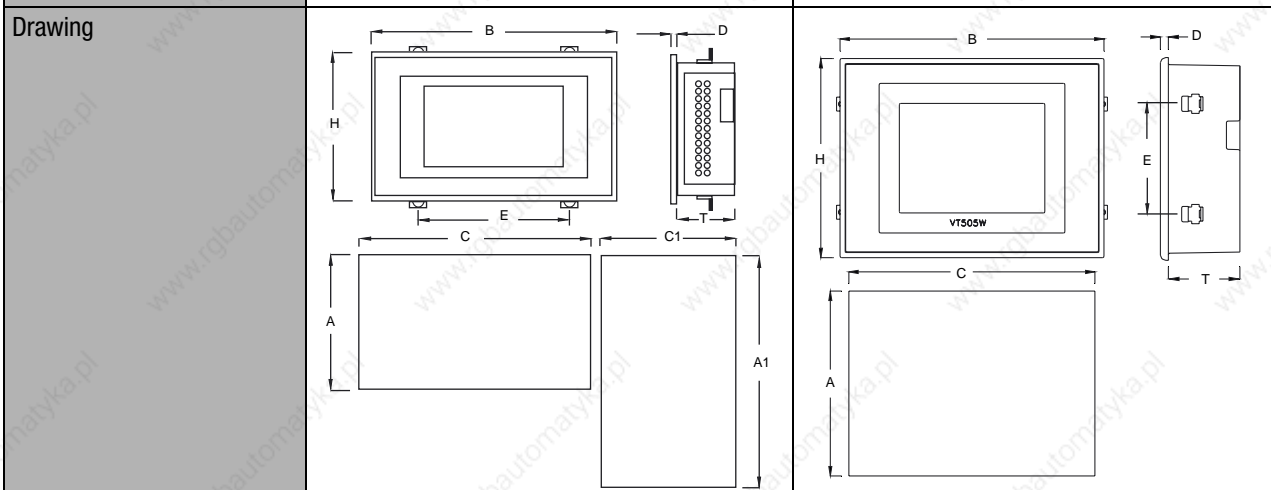

Programming of Operator Panels



VTWINCD

Order code

VTWIN

Program software
VT-series

Order code	VTWIN
Techn. data	
Software performance	<p>The program software VTWIN offers the following functions:</p> <ul style="list-style-type: none"> - Only one software for all Operator Panels - Configuration of RS232-interface - Configuration of CANopen-network - Text and graphic display free programmable - Set-up of Touch-Buttons (only VT155W and VT505W) - Project conversion of projects between the operator panels - free updates for new drivers and new functions
Hard- and software requirements	<ul style="list-style-type: none"> - Microsoft Windows® 95/98/ME or Windows® NT, 2000, XP - CD-ROM drive (recommended min. read 24-fold)
Supply package	<ul style="list-style-type: none"> - 1 CD-ROM to install VTWIN - Hard- and Software Manuals
Languages	<ul style="list-style-type: none"> - Selection out of five languages (German, English, French, Italian, Spanish)

Order Code	Licences
VTWIN	<ul style="list-style-type: none"> - Contains the full scope for parameter setting, control and monitoring. The software licence permits simultaneous use on any number of workstations. - We supply always the actual software version at time of delivery.

Cables for Operator Panels



Progming cable
CVCOM 11102

Adapter for programming cable
CVCOM 25F8M

RS-232 Interface cable to drive device OPK-
RS03

Order Code	Short explanation	Use
CVCOM 11102	Programming cable for connection between PC + Operator Panel (PC 9poles --> MSP 25poles)	necessary for all Operator Panels
CVCOM 25F8M	Adapter for programming cable, of PC 25poles --> ASP 8poles DIN-round plug (CVCOM 11102 must be available)	necessary for - VT050 000 CNN - VT150W 000 CNN - VT505W 000 CNN - VT155W 000 00N - VT155W 000 CNN
OPK-RS03 (Length = 3 m)	Serial RS232-interface cable to connect the Operator Panels with the drive device	suitable for - VT050 000 00N - VT150W 000 00N - VT505W 000 00N - VT155W 000 00N
OPK-RS05 (Length = 5 m)	Serial RS232-interface cable to connect the Operator Panels with the drive device	suitable for - VT050 000 00N - VT150W 000 00N - VT505W 000 00N - VT155W 000 00N

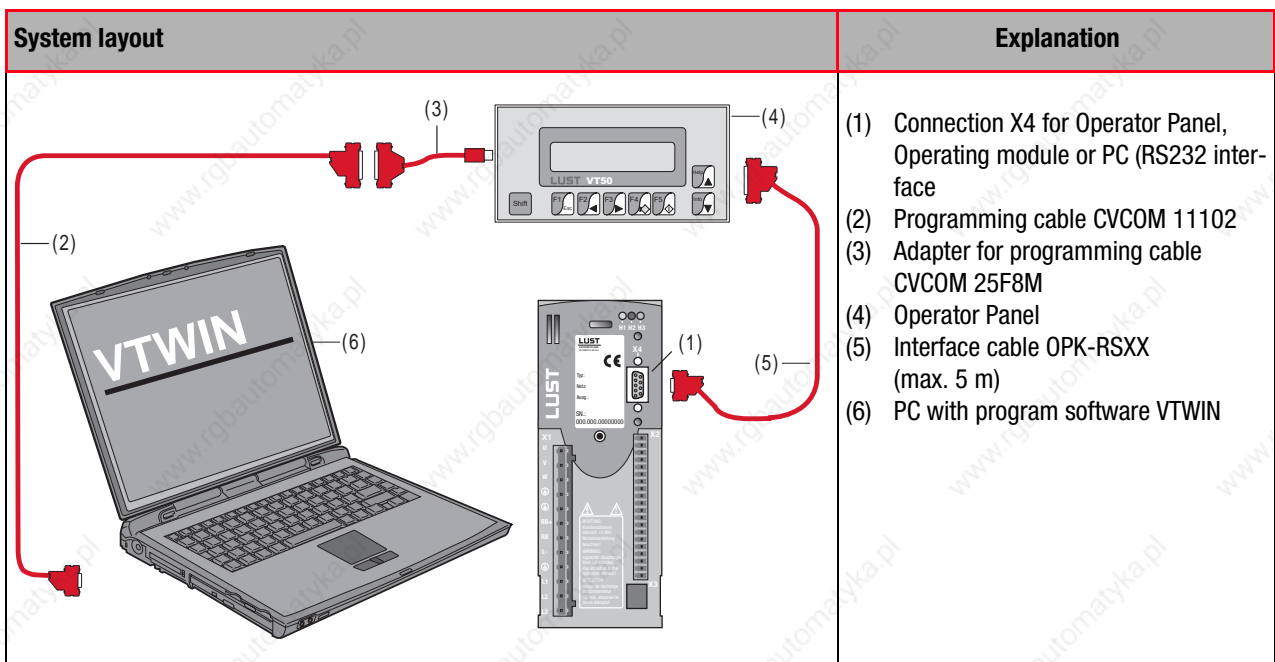



PLCEditor

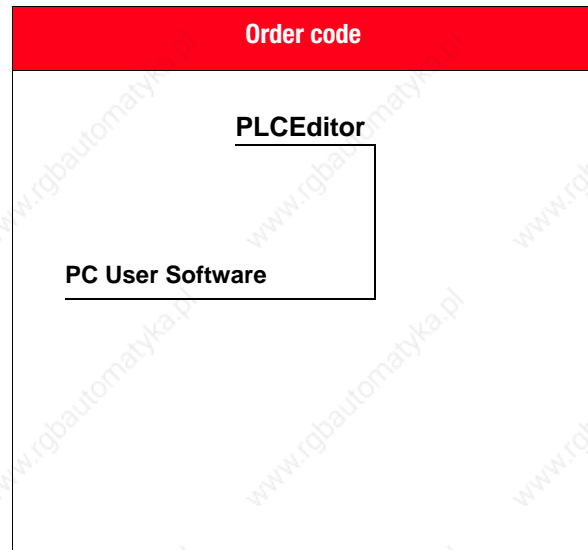

Order code	PLC-editor
Techn. data	
Software performance	<p>PC-User software „PLCEditor“ is a supplement to the DRIVEMANAGER:</p> <ul style="list-style-type: none"> • Editor for making of PLC-process program • Program-Handling <ul style="list-style-type: none"> – Load/ Save/ Print/ Regeneration of programs – Load/ Save a program from/in DRIVEMANAGER data set – Load/ Save a program from/in a connected drive device • Online-Help to the PLC-editor and to the command syntax with examples
Hard- and software requirements	<ul style="list-style-type: none"> - Microsoft Windows® 95/98/ME or Windows® NT, 2000, XP - Working memory (RAM) min 32 MB (recommended 64 MB) - CD-ROM drive (recommended read min. 24-fold)
Supply package	<ul style="list-style-type: none"> - 1 CD-ROM with PLC-program editor, PLC-program examples, - PLC-System manual as PDF (on CD-ROM) - Firmware CDA3000,PLC
Languages	<ul style="list-style-type: none"> - During installation selected German or English.

Order code	Licences
PLC-Editor	<ul style="list-style-type: none"> - Contains the full scope for programming of the PLC-firmware. The software licence permits simultaneous use on any number of workstations.

PC-User Software



DRIVEMANAGER 3.x

Order code

DRIVEMANAGER, 3.x

PC User Software

Software version

Order code	DRIVEMANAGER 3.x
Techn. data	
Software performance	<p>PC-User software „DRIVEMANAGER“ offers the following functions:</p> <ul style="list-style-type: none"> - Can be operated via comfortable adjusting masks, so easy handling is guaranteed - Status indication to control the operation-specific actual values and references - Direct control of the inverter via PLC - Comfortable four-channel digital scope for real-time recording of actual values, like current curve or VFC-diagram - Comparing function to solve problems, data management and print functions.
Hard- and software requirements	<ul style="list-style-type: none"> - Microsoft Windows® 95/98/ME or Windows® NT, 2000, XP - Working memory (RAM) min. 32 MB (recommended 64 MB) - CD-ROM drive (recommend min. 24-fold read)
Supply package	<ul style="list-style-type: none"> - 1 CD-ROM to install the user software DRIVEMANAGER - Manual DRIVEMANAGER - All application manuals as well as software descriptions of the single device series as pdf-documents.
Languages	<ul style="list-style-type: none"> - At installation select German, English or French.

Order Code	Licences
DRIVEMANAGER 3.x TEST	- Contains the full scope of functions and is intended for test and demo purposes. The runtime is limited to 180 days from date of installation.
DRIVEMANAGER 3.x	- Contains the full scope for parameter setting, control and monitoring. Unlimited running time. The software licence permits simultaneous use on any number of workstations.

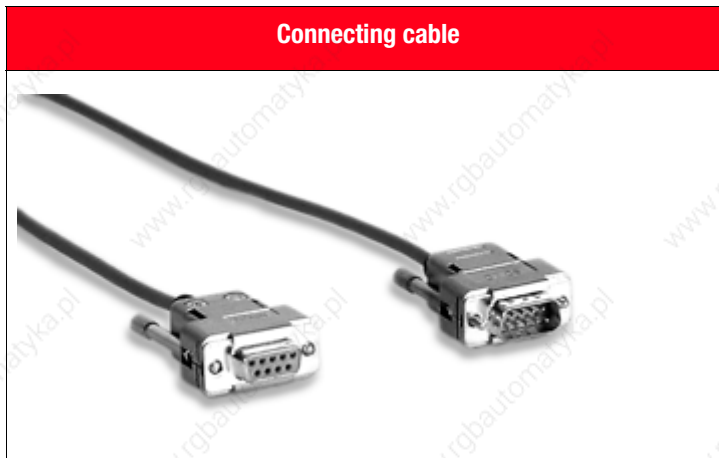

CCD-SUB 90x

Order code

	CC D-SUB 9 0x	
Connecting Cable		
Cable type D-SUB		
Cable length in meters		

Order code	Technical data
CCD-SUB 901	Cable for the connection between inverter module and KP200 or inverter module and PC with DRIVEMANAGER, length 1 m
CCD-SUB 902	Cable for the connection between inverter module and KP200 or inverter module and PC with DRIVEMANAGER, length 2 m
CCD-SUB 903	Cable for the connection between inverter module and KP200 or inverter module and PC with DRIVEMANAGER, length 3 m

System layout	Explanation
	<ol style="list-style-type: none"> (1) Connection X4 for operator module or PC RS232 interface (2) Chipcard SMARTCARD (3) Operator module KP200 (4) PC with user software DRIVEMANAGER (5) Connecting cable CCD-SUB90X, x.x



TB3

TB5

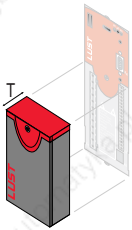
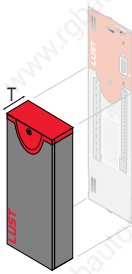
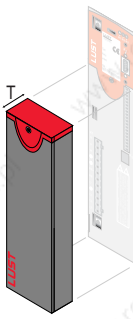
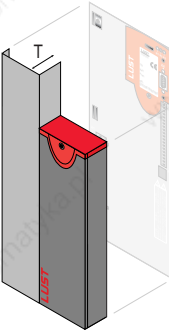
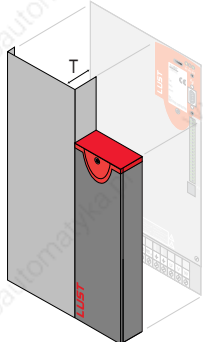
Order Code	TB1	TB2	TB3	TB4	TB5
Suitable for inverter module	CDA32.004	CDA32.006 CDA32.008 CDA34.003 CDA34.005 CDA34.006	CDA34.008 CDA34.010	CDA34.014 CDA34.017	CDA34.024 CDA34.032
Power output of inverter module	0.75 kW	1.1 kW 1.5 kW 0.75 kW 1.5 kW 2.2 kW	3.0 kW 4.0 kW	5.5 kW 7.5 kW	11.0 kW 15.0 kW
D(depth)	32.5 mm	32.5 mm	32.5 mm	32.5 mm	32.5 mm
Picture					



Hinweis: On inverter modules sizes 6, 7, 8 the terminal cover is included in delivery.

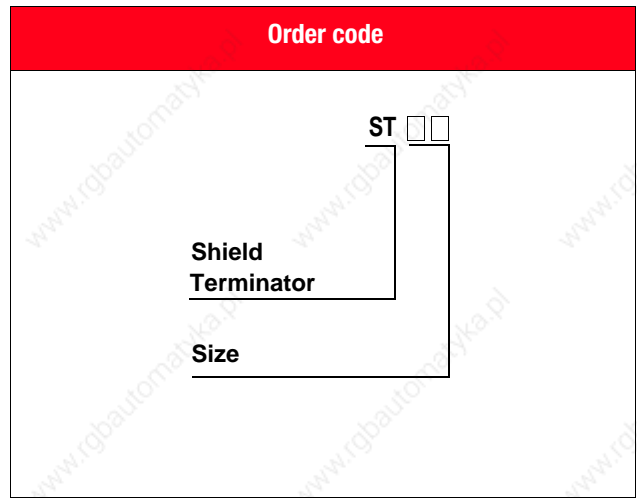
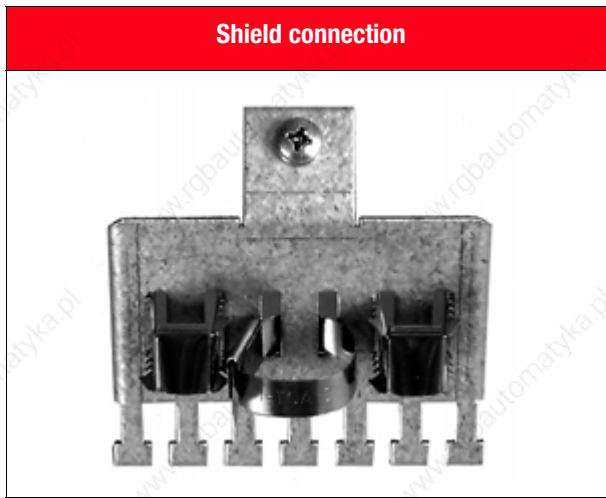

ST02 (incl. metal clips, metal cable binder and screw)

Order code	ST02			ST04	ST05
Techn. data					
Suitable for inverter module	CDA32.004	CDA32.006 CDA32.008 CDA34.003 CDA34.005 CDA34.006	CDA34.008 CDA34.010	CDA34.014 CDA34.017	CDA34.024 CDA34.032
Output power of inverter module	0.75 kW	0.75 .. 2.2 kW	3.0 ... 4.0 kW	5.5 ... 7.5 kW	11.0 ... 15.0 kW
H (height)	238 mm	263 mm	345 mm	345 mm	355 mm
Pictures					



Hinweis: For the inverter modules sizes 6,7,8 (cable cross-section >32 mm²) we recommend to connect the shields of the motor/mains lead directly to a shield rails in the cabinet.



Metal clips

SMC50

Order code

SMC

Shield Metal Clip

360° - contacts

Quantity of packing unit

Order code	Packing unit	suitable for EMV-shielding	useable for cable shield diameter	Material
SMC50	50 pcs.	ST xx	< 12 mm ²	spring steel

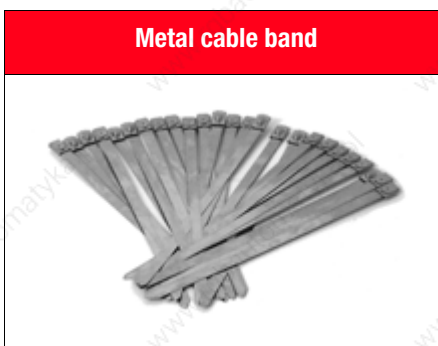

Metal cable band

SMB50

OcCode

SMB

Shield Metal Band

360° - contacts

Quantity of packing unit

Order code	Packing unit	suitable for EMV-shielding	useable for cable shield diameter	Material
SMB50	50 pcs.	ST xx	> 12mm ²	stainless steel

System layout



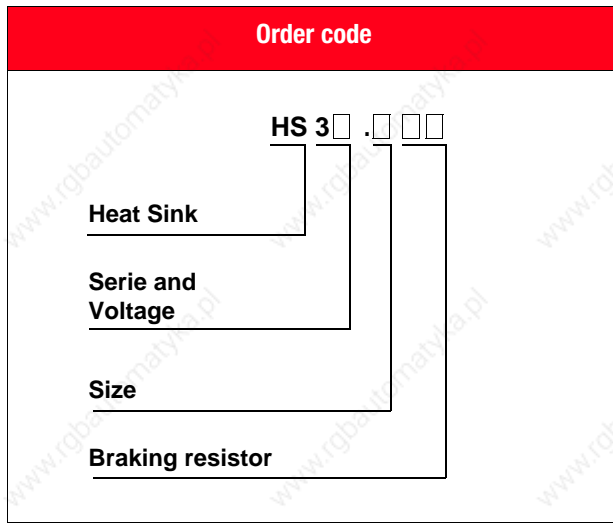
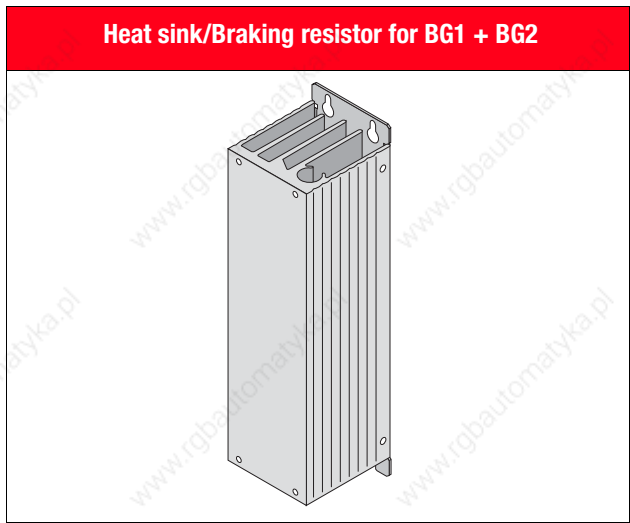

HS3X.xxx

Order code	HS32.1BR	HS32.200	HS32.2BR	HS34.2BR
Tech. data				
Continuous braking power at mounting on inverter module	CDA32.004 / 25 W	-	CDA32.006 / 30 W CDA32.008 / 0 W	CDA34.003 / 35 W CDA34.005 / 5 W
Braking resistor	162 Ω	-	90 Ω	360 Ω
Peak braking power	0.9 kW	-	1.7 kW	1.6 kW
Heat sink for end-to-end mounting of inverter modules	-	CDA32.006 CDA32.008 CDA34.005	-	-

Order code	Description	Dimensions						
		W (Width) [mm]	H (Height) [mm]	D (Depth) [mm]	A [mm]	C [mm]	D [mm]	E [mm]
HS32.1BR	Heat sink with integrated braking resistor (230 V Net)	70	215	75	40	235	∅4.8	245
HS32.200	Heat sink	70	240	75	40	260	∅4.8	270
HS32.2BR	Heat sink with integrated braking resistor (230 V Net)							
HS34.2BR	Heat sink with integrated braking resistor (460 V Net)							

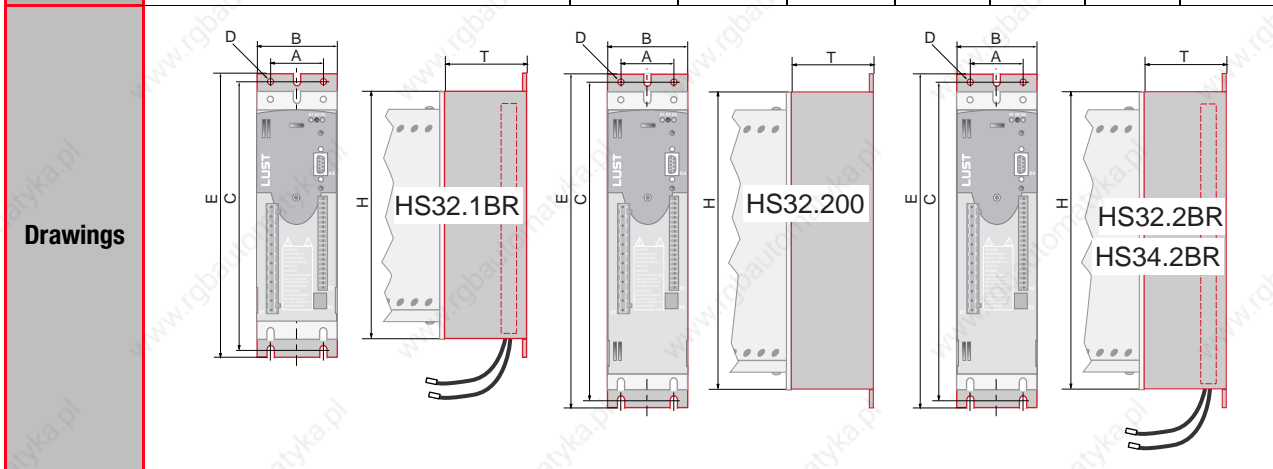

Overview user and communication modules

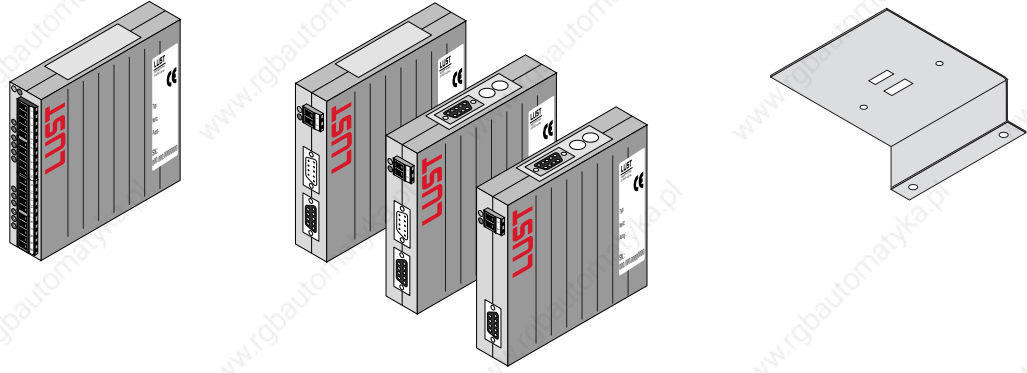

Index	User modules	Communication modules	Mounting package
Type	UM-8I40	CM-CAN1 CM-CAN2 CM-DPV1	MP-UMCM
Page	4 - 2	4 - 3	4 - 5

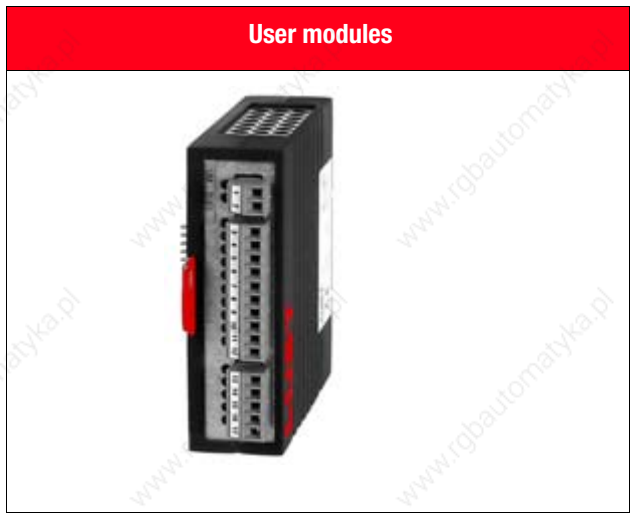

UM-8140

Order code

UM - □□□□

User Module

Characteristics

8 | 4 | 0 (e.g.)

Terminal extension by 4 outputs

Terminal extension by 8 inputs

Order code	Short description
UM-8140	Terminal extension by 8 inputs and 4 outputs, programmable functions of I/O's

Technical data	UM-8140		
Supply voltage	24 VDC ±20 %		
Current consumption	0.6 A		
Eight inputs	Input voltage for signal „0“	from 0 to 5 V	
	Input voltage for signal „1“	>15 V	
	Input voltage with signal „1“	3.5 mA to 7.0 mA (6 mA at 24 VDC)	
Four outputs	Output current	allowed range with signal „1“	min. 5 mA max. 0.5 A
		Mean	125 mA
		Total current	0,5 A
		Short-circuit current per output	max. 1.2 A short-time
Dimensions (W x H x D)	28 x 90 x 90 [mm]		

System layout UM-8140	Explanation
	<ol style="list-style-type: none"> (1) Inverter module CDA3000 (2) User module UM-8140 (3) External power pack 24 VDC (4) Eight control inputs (programmable) (5) Four control outputs (programmable)

Communication modules



CM-CAN1, CM-CAN2, CM-DPV1

Order code

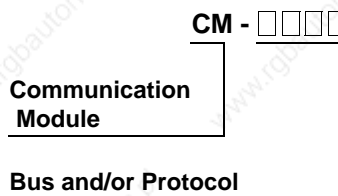

Order code	Short description
CM-CAN1	Communication module for CAN-Bus with data transfer protocol CAN _{Lust}
CM-CAN2	Communication module for CAN-Bus with data transfer protocol CAN _{open}
CM-DPV1	Communication module for PROFIBUS-DPV1 (for actual GSD-file see our homepage www.lust-tec.de)

Technical data	CM-CAN1	CM-CAN2	CM-DPV1
Standardization	ISO 11898	ISO 11898	EN 50170
Communication	CiA/ DS102	CiA/ DS301	Directive 2.084
Device profile	DRIVECOM	CiA/ DS402	PROFIBUS
Transfer rate/ cable length	25 kBit/s up to 1000 m 500 kBit/s up to 100 m	20 kBit/s up to 1000 m 1 MBit/s up to 40 m	9.6 kBit/s up to 1200 m 12 MBit/s up to 100 m
Voltage supply	19 ... 29 VDC	18 ... 30 VDC	18 ... 30 VDC
Current consumption	max. 80 mA	max. 100 mA	max. 250 mA
Dimensions (W x H x D)	28 x 90 x 90 [mm]		

System layout CAN_{LUST}/ CAN_{open}

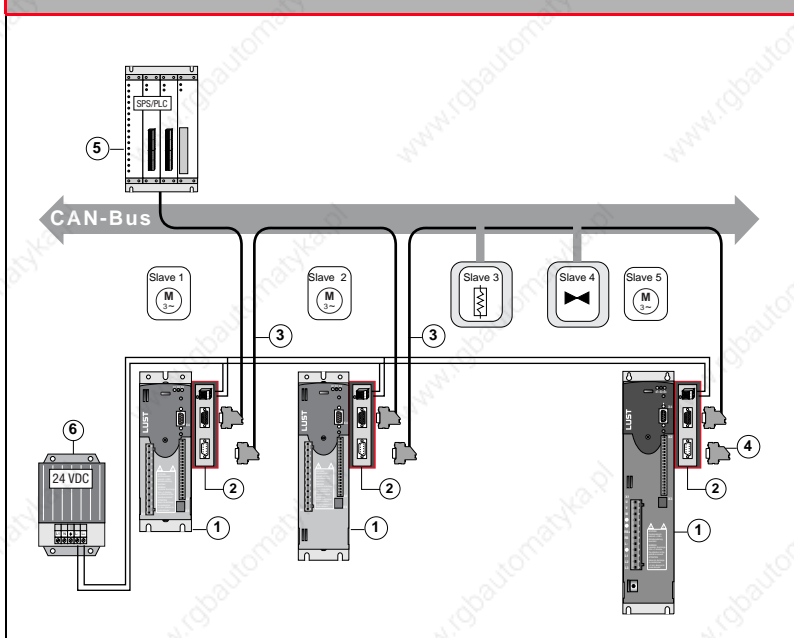

Explanation

- (1) Inverter module CDA3000
- (2) Communication module CM-CAN1 or CM-CAN2
- (3) Connecting cable CCD 90x, x.x
- (4) Bus termination plug
- (5) CAN-Bus control
- (6) Power pack (24 VDC)

max. 100 stations

System layout PROFIBUS-DP

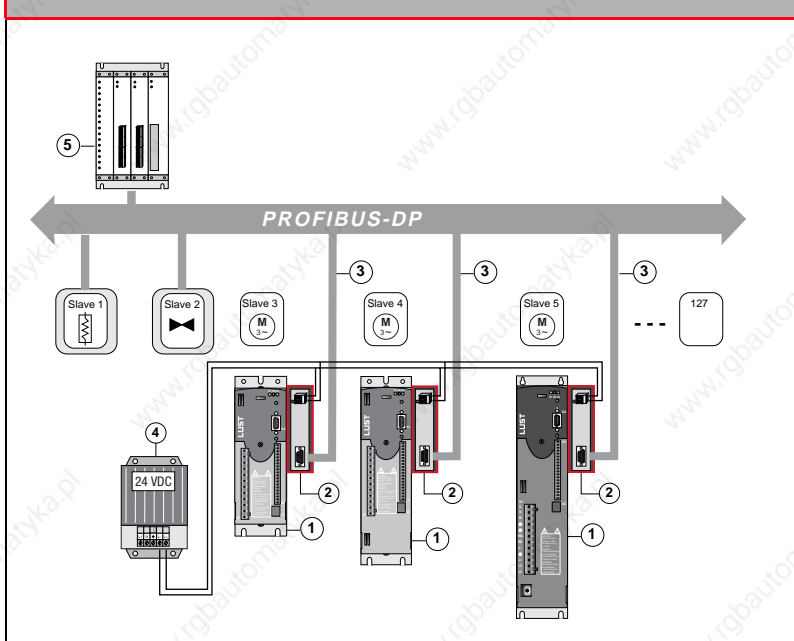

Explanation

- (1) Inverter module CDA3000
- (2) Communication module CM-DPV1
- (3) PROFIBUS-DP system cable
- (4) Power pack 24 VDC
- (5) DP-Master

max. 127 stations

Mounting package for UMxxx and CMxxx

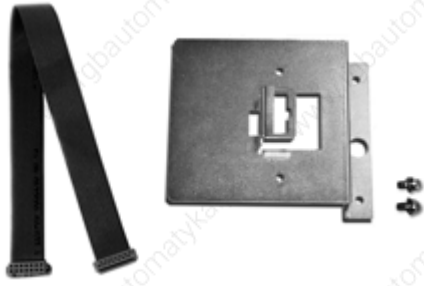

MP-UMCM

Order code

MP -

Mounting Package

Type

System selection

Invertermodule

Accessories for Invertermodule

User- und Communicationmodule

Supplementary Componentes

LUST

Order code	Short description
MP-UMCM	The mounting package is for fixing the user/communication module to inverter modules size BG6, BG7 and BG8.

System layout	Explanation
	<ol style="list-style-type: none"> (1) Plug-in connection X7 (communication module) (2) Plug-in connection X6 (user module) (3) Control terminals (4) KP200 (5) Slot for user module (z.B. UM-8140) (6) Slot for communication module 2 (e.g. CM-CAN1)

Overview supplementary components

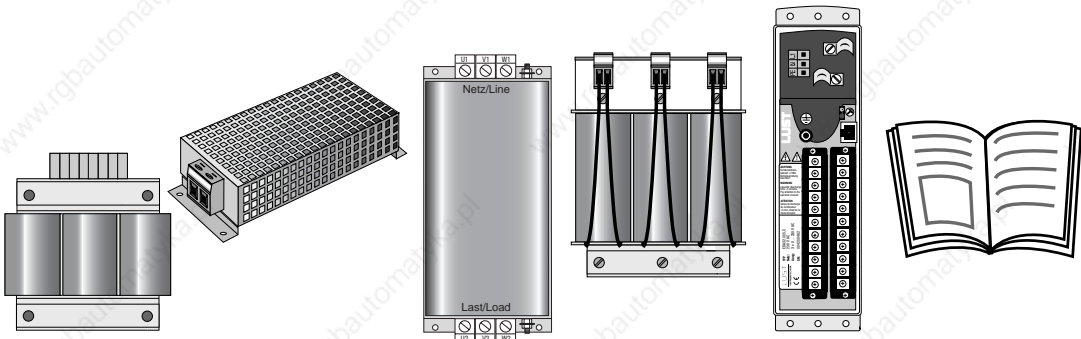

Index

	Line chokes	Braking resistors	Mains filters	Motor choke motor filter	Inverter for simple applications	User information
Type	LR 32.4 LR32.8 LR34.4 LR34.170	BR-270.01, 540 ... BR-010.80, 541	EMCxxx.X	MR34.xxx MRF34.xxx	ED1200	all paper documents
Page	5 - 2	5 - 5	5 - 8	5 - 12	5 - 16	5 - 17

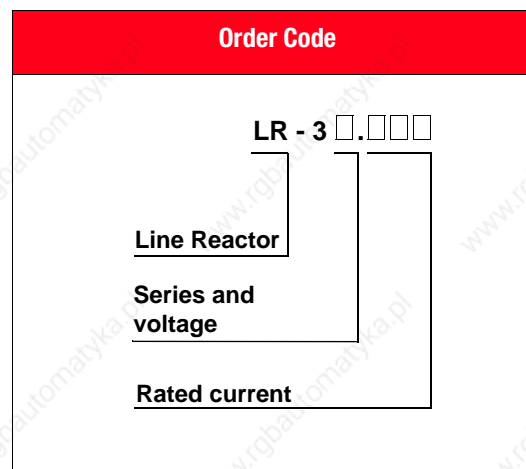

LR34.10

Ambient conditions	LR 32. xxx	LR 34. xxx
Rated voltage	1 x 230 V, -20 % +15 %, 50/60 Hz ¹⁾	3 x 460 V, -25 % +10 %, 50/60 Hz ¹⁾
Overload factor	1.8 x I _N for 40 s	1.8 x I _N for 40 s up to rated current of 32 A 1.5 x I _N for 60 s from rated current of 45 A
Ambient temperature	-25° C up to +45° C, with power loss up to 60° C (1,3 % / °C)	
Mounting height	1000 m, with power loss up to 4000 m (6 % / 1000 m)	
Relative humidity	15 ... 95 %, condensation not permitted	
Storage temperature	-25° C up to +70° C	
Protection kind	IP00, terminals VBG4	
Short-circuit voltage	U _K 4 % at 230 V = 9,2 V	U _K 4 % at 400 V = 9,24 V
Permissible contamination	P2 according to EN 61558-1	P2 according to EN 61558-1
Thermal configuration	I _{eff} < I _N	
UL-Recognition	Execution LR3X.xxx-UR has the UL-Recognition for the markets in USA and Canada	

¹⁾ at mains frequency 60 Hz the power loss increases by approx. 5 - 10 %.

Single-phase line chokes						
Techn. data	Suitable for inverter modules	Rated current [A]	Power loss total [W]	Inductance [mH]	Weight [kg]	Connection [mm ²]
Order code						
LR32.8/ LR32.8-UR	CDA32.004, ED1200	8	10	3.66	0.8	4
LR32.14/ LR32.14-UR	CDA32.006 CDA32.008	14	16	2.1	1.5	4
LR32.5/ LR32.5-UR ¹⁾	CDA32.004, ED1200 (Recommended rated power with 4-pole standard motor = 550 W)	4.5	11	9.76	0.7	4

¹⁾ U_K = 6% at 230V = 13,8V (to conform to EN 61000-3-2).

Single-phase line chokes			
Dimensions [mm]	LR32.8	LR32.5	LR32.14
W (Width)	60	60	85
H (Height)	75	75	100
D (Depth)	57	57	65
A	44	44	64
C	46	46	50
D	∅ 4.8	3.6	∅ 4.8
Drawing:			

Three-phase line chokes							
Order code	Techn. data	Suitable for inverter modules	Rated current [A]	Power loss total [W]	Inductance [mH]	Weight [kg]	Connection [mm ²]
LR34.4/ LR34.4-UR		CDA34.003	4.2	20	7	1.6	4
LR34.6/ LR34.6-UR		CDA34.005 CDA34.006	6	26.1	4.88	2.0	4
LR34.8/ LR34.8-UR		CDA34.008	8	29	3,66	2.4	4
LR34.10/ LR34.10-UR		CDA34.010	10	33	2.93	3.0	4
LR34.14/ LR34.14-UR		CDA34.014	14	45	2.09	3.8	4
LR34.17/ LR34.17-UR		CDA34.017	17	45	1.72	4.5	4
LR34.24/ LR34.24-UR		CDA34.024	24	50	1.22	5.8	4
LR34.32/ LR34.32-UR		CDA34.032	32	67	0.92	6.7	10
LR34.45/ LR34.45-UR		CDA34.045	45	73	0.65	8.5	10
LR34.60/ LR34.60-UR		CDA34.060	60	85	0.49	10.0	10
LR34.72/ LR34.72-UR		CDA34.072	72	111	0.41	14.0	16
LR34.90/ LR34.90-UR		CDA34.090	90	135	0.33	20.0	35
LR34.110/ LR34.110-UR		CDA34.110	110	126	0.27	22.0	35
LR34.143/ LR34.143-UR		CDA34.143	143	168	0.21	28.0	70
LR34.170/ LR34.170-UR		CDA34.170	170	218	0.18	30.0	70
LR34.250/ LR34.250-UR		CDA34.250	250	270	0.135	40.0	M10

Three-phase line chokes																
Dimensions [mm]	LR34.4	LR34.6	LR34.8	LR34.10	LR34.14	LR34.17	LR34.24	LR34.32	LR34.45	LR34.60	LR34.72	LR34.90	LR34.110	LR34.143	LR34.170	LR34.250
W (Width)	100	125	125	125	155	155	155	190	190	190	230	230	230	265	300	300
H (Height)	120	140	140	140	160	160	160	195	195	195	275	280	280	330	360	360
D (Depth)	70	65	65	75	80	80	95	85	95	105	125	150	150	145	155	200
A	63	100	100	100	130	130	130	170	170	170	180	180	180	215	240	240
C	50	47	47	57	57	57	74	57	67	77	98	122	122	118	120	137
D \varnothing	5,8	5	5	5	8	8	8	8	8	8	8	8	8	11	11	11
Drawing:																

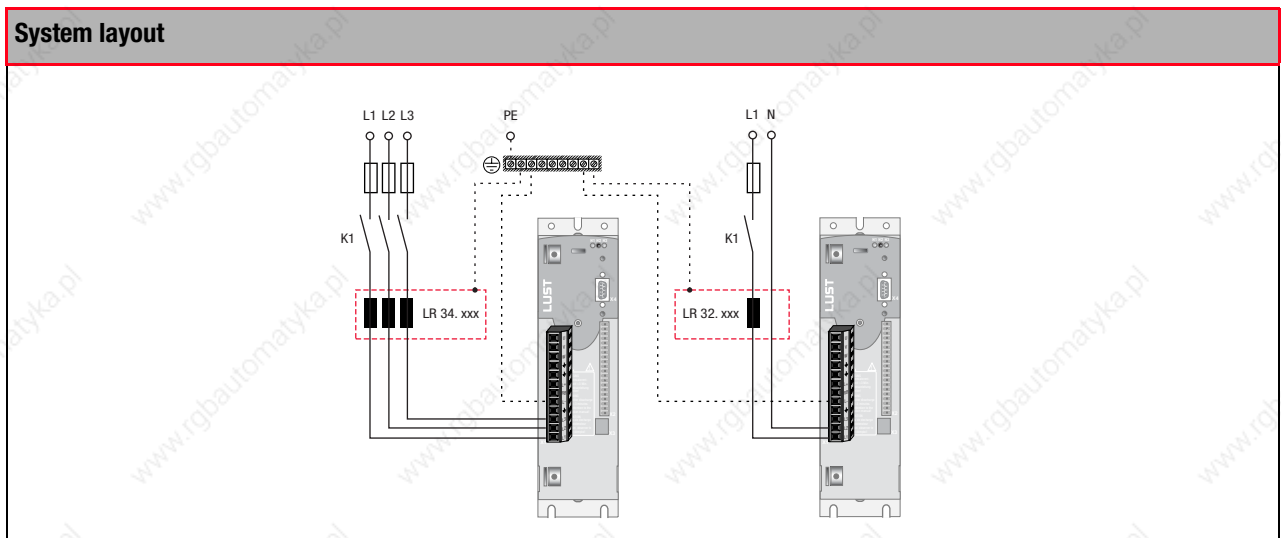

Braking resistor

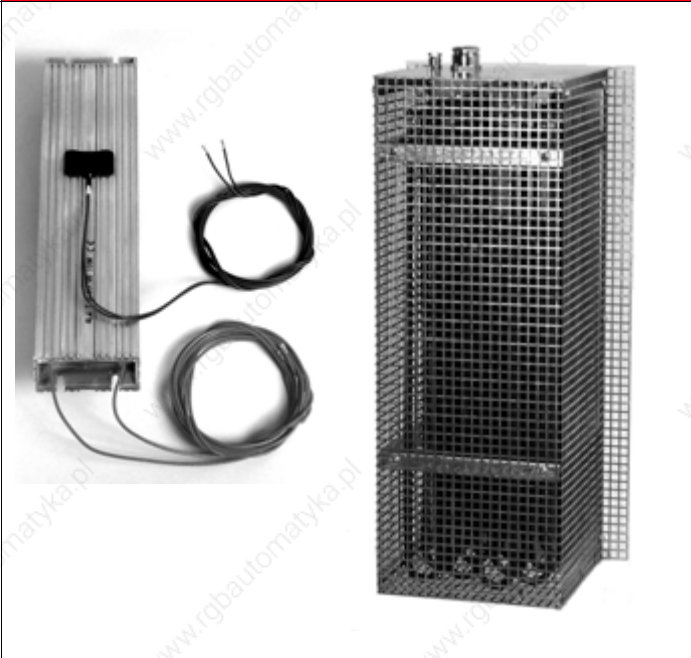

BR-270.02, 540

BR-042.20, 201

Order code

BR - □□□.□□, □□□

Braking Res.

Ω Value

Power in [W]
01 = 100 W
10 = 1 kW

Termination

1 = with touch protection
0 = w/o touch protection

Design	as per diagram A1 and A11	as per diagram A2	as per diagram A3 and A4
Technical data			
Surface temperature	> 200° C	< 80° C	< 80° C
Touch protection	no	yes (< 80° C)	yes (< 80° C)
Voltage	max. 800 V	max. 800 V	max. 800 V
High-voltage strength	4000 V	4000 V	1800 V
Temperature control	yes with bimetal protector (switching capacity 0.5 A/ 230 V)		
Acceptances	CE-conform		
UL-Recognition	in preparation		no
Connection	1 m long PTFE - insulated litz wire	Ceramic terminals	Ceramic terminals
Diagrams			

Braking resistors						
Techn. data Order code	Cont. brake power [W]	Resistor [$\Omega \pm 10\%$]	Peak braking power [W]		Protection	Diagram
			390 VDC ¹⁾	750 VDC ²⁾		
BR-270.01, 540 ⁴⁾	35	270	560	2080	IP23	A11
BR-160.01, 540 ⁴⁾	35	160	950	3)	IP23	A11
BR-090.01, 540 ⁴⁾	35	90	1690	3)	IP23	A11
BR-110.01, 540 ⁴⁾	35	110	1380	3)	IP23	A11
BR-110.02, 540 ⁴⁾	150	110	1380	5110	IP23	A1
BR-200.02, 540 ⁴⁾	150	200	760	2810	IP23	A1
BR-270.02, 540 ⁴⁾	150	270	560	2080	IP23	A1
BR-160.02, 540 ⁴⁾	150	160	950	3500	IP23	A1
BR-110.03, 541	300	110	1380	5110	IP23 ⁵⁾	A2
BR-200.03, 541	300	200	760	2810	IP23 ⁵⁾	A2
BR-270.03, 541	300	270	560	2080	IP23 ⁵⁾	A2
BR-160.03, 541	300	160	950	3500	IP23 ⁵⁾	A2
BR-090.03, 541	300	90	1690	6250	IP23 ⁵⁾	A2
BR-090.10, 201	1000	90	1690	6250	IP20	A3
BR-090.10, 541	1000	90	1690	6250	IP23 ⁵⁾	A4
BR-042.20, 201	2000	42	-	13390	IP20	A3
BR-042.20, 541	2000	42	-	13390	IP23 ⁵⁾	A4
BR-015.60, 541	6000	15	-	37500	IP23 ⁵⁾	A4
BR-010.80, 541	8000	10	-	56250	IP23 ⁵⁾	A4

1) 1 x 230 V mains connection -20% +15%

2) 3 x 460 V mains connection -25% +10%

3) Not permitted for operation on inverter modules with 3 x 400/460 V mains connection.

4) The braking resistors can be operated at double continuous braking power if provided with optimum cooling.

5) Adapter box in IP54

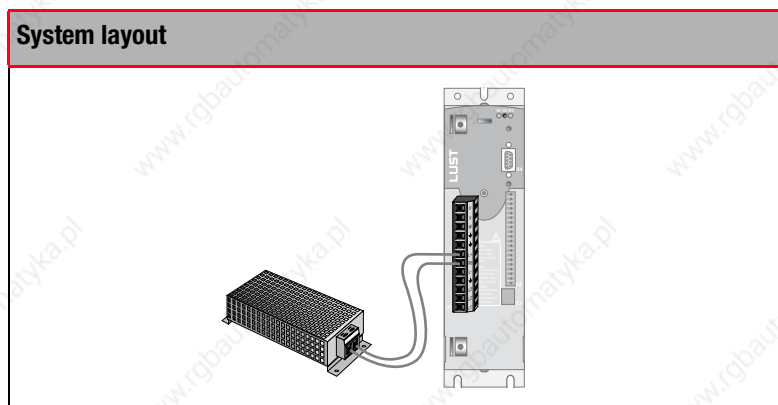

Braking resistors

Dimension [mm]	BR-270.01, 540	BR-160.01, 540	BR-090.01, 540	BR-110.01, 540	BR-110.02, 540	BR-200.02, 540	BR-270.02, 540	BR-160.02, 540
W (Width)	40	40	40	40	80	80	80	80
H (Height)	160	160	160	160	300	300	300	300
D (Depth)	26	26	26	26	20	20	20	20
A	-	-	-	-	41.5	41.5	41.5	41.5
C	146	146	146	146	282	282	282	282
DØ	6.0	6.0	6.0	6.0	5.5	5.5	5.5	5.5
Diagram	A11	A11	A11	A11	A1	A1	A1	A1

Dimensions [mm]	BR-110.03, 541*)	BR-200.03, 541*)	BR-270.03, 541*)	BR-160.03, 541*)	BR-090.03, 541*)	BR-090.10, 201*)	BR-090.10, 541*)	BR-042.20, 201*)	BR-042.20, 541*)	BR-015.60, 541*)	BR-010.80, 541*)
W (Width)	102	102	102	102	102	200	200	200	200	200	200
H (Height)	400	400	400	400	400	550	605	550	605	605	605
D (Depth)	80	80	80	80	80	200	200	200	200	200	200

A

C

DØ

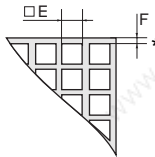

*) Fixing brackets are made of perforated sheet metal
Web width F = 2 mm
Grid square E = 8 mm

Diagram	A2	A2	A2	A2	A2	A3	A4	A3	A4	A4	A4
---------	----	----	----	----	----	----	----	----	----	----	----

Drawings

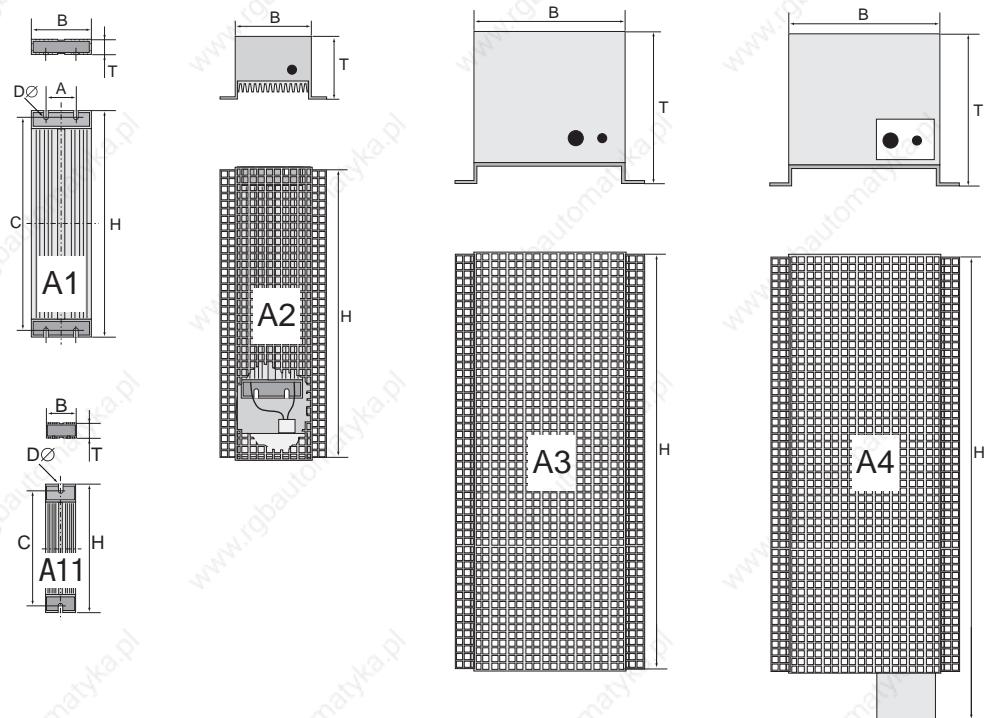

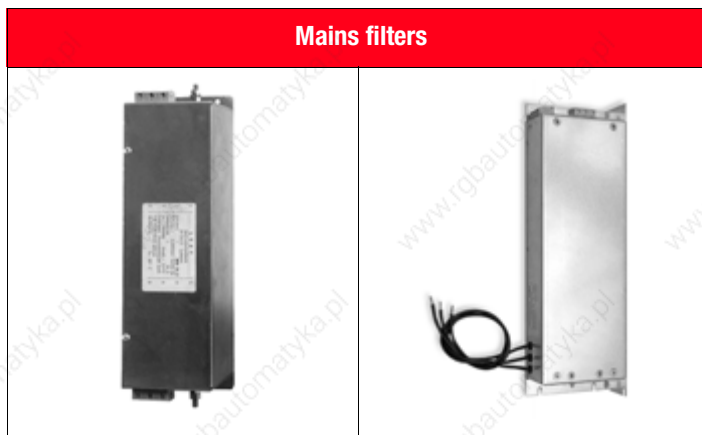

EMC50.0

EMC17.U/S

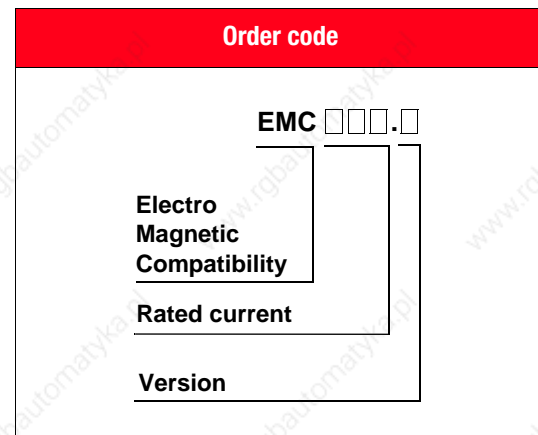

Ambient conditions	EMCxx.x
Mains voltage	3 x 480 V, max. +10 %, 50/60 Hz
Ambient temperature	typical -25° C up to +40° C, with power loss up to 60° C (1.3 % / ° C)
Mounting height	1000 m, with power loss up to 4000 m (6 % / 1000 m)
Relative humidity	15 ... 85 %, condensation not permitted
Transport / Storage temperature	-25° C up to +70° C/ -40° C up to +85° C
Protection	IP00, Input terminals VBG4
Permissible contamination	P2 according to EN 61558-1
UL-Recognition	Version EMCxxx-UR has UL Recognition for the USA and Canadian markets
Radio interference suppression EN61800-3 -residential-	Motor cable length up to 100 m permitted
Radio interference suppression EN61800-3 -industrial-	Motor cable length up to 150 m permitted

Three-phase mains filters						
Techn. data Order code	Suitable for inverter modules	Rated current [A]	Power loss total [W]	Inductance [mH]	Weight [kg]	Connection [mm ²]
EMC 10.0, EMC 10.0-UR	CDA34.008 CDA34.010	10	13	< 1.3	1.7	0.2...4, PE M5
EMC 17.0 EMC 17.0-UR	CDA34.014 CDA34.017	17	21	< 1.2	1.8	0.2...4, PE M5
EMC 35.0 EMC 35.0-UR	CDA34.024 CDA34.032	35	27	< 1.1	2.5	0.2...6, PE M5
EMC 50.0 EMC 50.0-UR	CDA34.045 ¹⁾	50	31	< 1.1	3.4	0.5...16, PE M5
EMC 63.0	CDA34.060 ¹⁾	63	53	< 1.1	6.0	0.5...16, PE M6
EMC 80.0	CDA34.072 ¹⁾	80	68	< 1.1	6.0	0.75...35, PE M8
EMC 100.0	CDA34.090 ¹⁾	100	68	< 1.3	6.0	0.75...35, PE M8
EMC 125.0	CDA34.110 ¹⁾	125	82	< 1.3	10.0	16...50, PE M10
EMC 150.0	CDA34.143 ¹⁾	150	88	< 1.4	10.0	35...95, PE M10
EMC 180.0	CDA34.170 ¹⁾	180	150	< 1.1	15.5	Bolt M12
EMC 250.0	CDA34.250 ¹⁾	250	180	< 1.5	18.2	Bolt M12

1) Inverter modules (CDA34.045 to CDA34.250) have to be operated with line chokes.

Three-phase mains filters

Dimensions [mm]	EMC 10.0/ 17.0/35.0	EMC 50.0	EMC 63.0	EMC 80.0	EMC 100.0	EMC 125.0	EMC 150.0	EMC 180.0	EMC 250.0
Drawing	Type Ia	Type Ib	Type II				Type III		
W (Width)	270	290	330	325	325	345	345	490	490
H (Height)	55	90	150	150	150	175	175	170	230
D (Depth)	100	100	103	107	107	127	135	158	158
G	260	325	366	340	340	416	428	629	655
C	260	275	315	310	310	330	330	470	260
E	36	76	105	105	105	120	120	110	170
DØ	Ø 4.5	Ø 4.5	Ø 7	Ø 7	Ø 7	Ø 7	Ø 7	Ø 8.5	Ø 8.5

Drawing: Type Ia +Ib

1) litz wire at type Ia:
 EMC10.0: litz wire AWG 14/
 2,08 qmm, length 400 mm
 EMC17.0: litz wire AWG 12/
 3,31 qmm, length 400 mm
 EMC35.0: litz wire AWG 10/
 5,26 qmm, length 400 mm

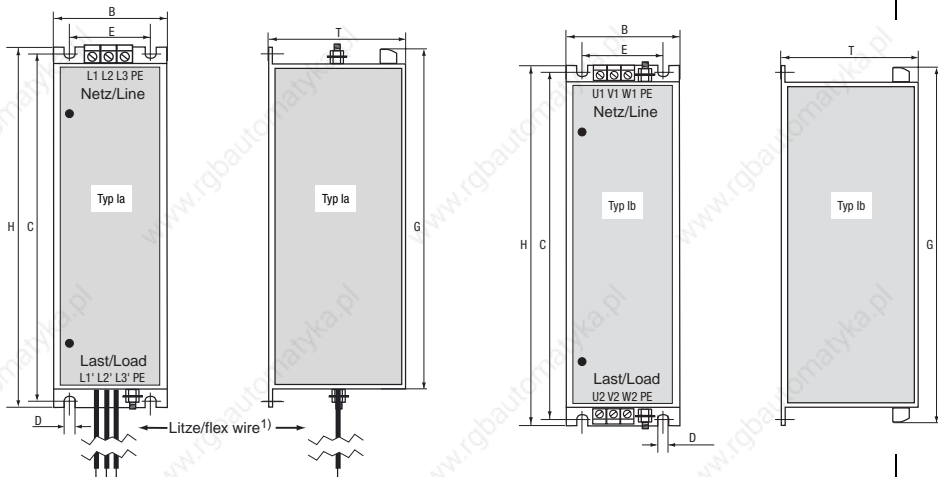

Drawing: Type II

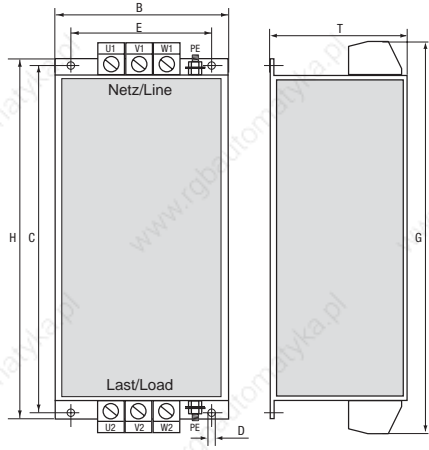

Drawing: Type III

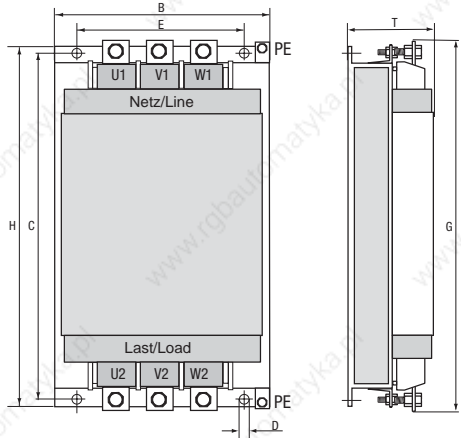

Three-phase base-side mounting mains filters						
Techn. data Order code	Suitable for inverter modules	Rated current [A]	Power loss total [W]	Inductance [mH]	Weight [kg]	Connection [mm ²]
EMC10.U/S EMC10.U/S-UR	CDA34.008 CDA34.010	10	12.5	< 1.3	2.0	0.2 ... 4.0 PE M5
EMC17.U/S EMC17.U/S-UR	CDA34.014 CDA34.017	17	21	< 1.2	3.5	0.2 ... 4.0 PE M5
EMC35.U/S EMC35.U/S-UR	CDA34.024 CDA34.032	35	21	< 1.1	4.0	0.2 ... 6.0 PE M5
EMC 50.U EMC 50.U-UR	CDA34.045	50	31	< 1.1	4.5	0.5...16, PE M8
EMC 63.U	CDA34.060	63	53	< 1.1	8.1	0.5...16, PE M8
EMC 80.U	CDA34.072	80	68	< 1.1	8.2	10...25, PE M8

Three-phase base-side mounting mains filters				
Dimensions[mm]	EMC10.U/S	EMC17.U/S	EMC35.U/S	EMC 50.U, EMC 63.U, EMC 80.U
W (Width)	385	385	385	430
H (Height)	70	120	170	250
D (Depth)	55	55	55	100
A	40	40	40	-
C	370	370	370	415
E	50	80	130	190
F	40	80	130	215
M	320			360
O	340			390
DØ	Ø 5.5			Ø 7

*The filters in base-mounting execution are only suitable for mounting under inverter modules version CDA34.xxx.W.

Three-phase base-side mounting mains filters

Dimensions[mm]	EMC10.U/S	EMC17.U/S	EMC35.U/S	EMC 50.U, EMC 63.U, EMC 80.U
Drawing: EMC10.U/S EMC17.U/S EMC35.U/S				
Drawing: EMC50.U EMC63.U EMC80.U				

*The filters in base-mounting execution are only suitable for mounting under inverter modules version CDA34.xxx.W.

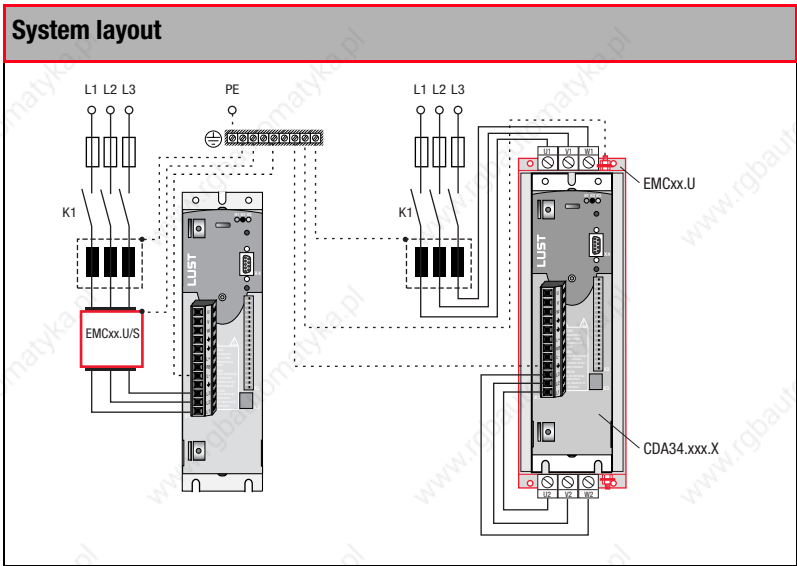

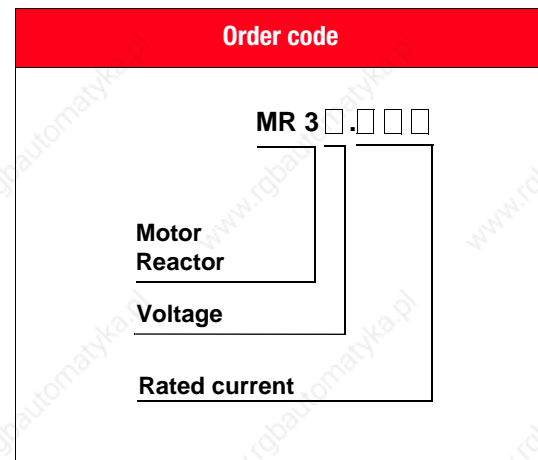

MR34.10

Ambient conditions	MR34.xxx
Rated voltage	3 x 460 V, +10 %
Overload factor	1.8 x I _N for 40 s up to a rated current of 32 A 1.5 x I _N for 60 s at rated current from 45 up to 170 A
Ambient temperature	-25° C up to +45° C, with power loss up to 60° C (2.5 % / ° C)
Mounting height	1000 m, with power loss up to 2000 m (12.5 % / 1000 m)
Relative humidity	15 ... 85 %, condensation is not permitted
Storage temperature	-25° C up to +70° C
Protection	IP00, terminals VBG4
Permissible contamination	P2 according to EN 61558-1, vertical wall mounting
Connections	up to type MR34.24 screw terminals, larger motor chokes flat terminals with threaded bolt
UR-Recognition	all motor chokes have the UL-Recognition for the markets in the USA and Canada
Rotating field frequency/ clock frequency power stage	max. 150 Hz/ 4 up to 8 kHz
Standstill torque (Rotating field zero)	all 120 s, max. 5 s
du/dt	typical < 1000 V/ μs

Motor chokes							
Techn. data Order code	Suitable for inverter module	Rated current [A]	Power loss [W]	Motor cable max. length [m]	max. capacitance per unit length [pF/m]	Inductanc e [mH]	Weight [kg]
MR34.10	CDA32.004 bis CDA34.010	9.4	70	30	L - L = 140 L - screen = 210	0.9	4.5
MR34.24	CDA34.014 bis CDA34.024	24	120	50	L - L = 140 L - screen = 210	0.45	10
MR34.45	CDA34.032 CDA34.045	46	130	50	L - L = 170 L - screen = 260	0.15	10.3
MR34.90	CDA34.060 bis CDA34.090	91	145	30	L - L = 190 L - screen = 300	0.05	10.5
MR34.110	CDA34.110	150	160	50	L - L = 190 L - screen = 300	0.05	20
MR34.170	CDA34.143 CDA34.170	176	210	30	L - L = 190 L - screen = 300	0.05	28

Motor chokes							
Dimensions[mm]	MR34.10	MR34.24	MR34.45	MR34.90	MR34.110	MR34.170	MR34.250
Drawing	Type I			Type II			
W (Width)	160	193	182	182	205	205	?
H (Height)	155	190	210	210	240	240	?
D (Depth)	85	115	120	120	131	165	?
D	130	170	175	175	190	190	?
E	70	75	85	85	95	129	?
G	90	100	105	105	121	155	?
C	M5	M6	M6	M6	M8	M8	?
Drawing: Type I							
Drawing: Type II							

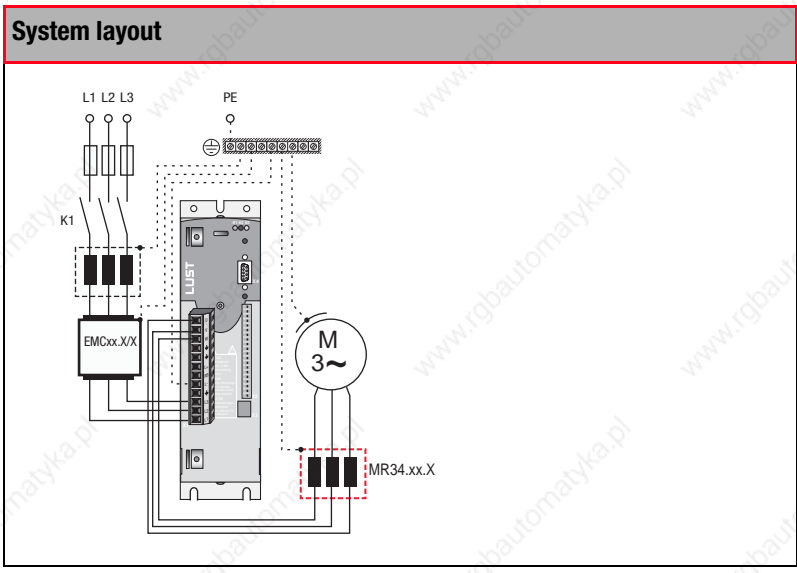



MRF34.45

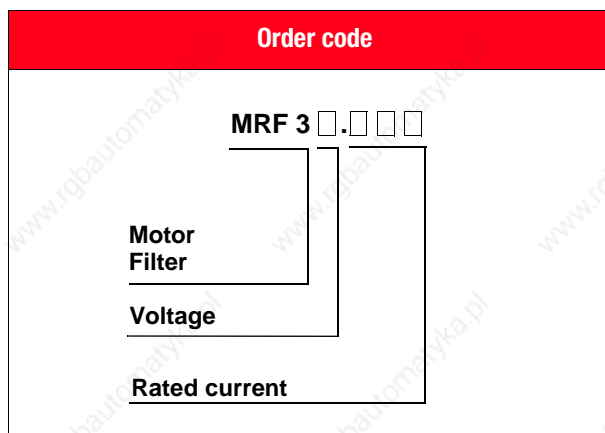

Ambient conditions	MRF34.xxx
Execution	Motor choke with condenser for inverters acc. to EN61558, VDE0570
Rated voltage	3 x 460 V, +10 %
Overload factor	1.8 x I _N for 40 s up to rated current of 32 A 1.5 x I _N for 60 sat rated current from 45 up to 250 A
Ambient temperature	-25° C up to +45° C, with power loss up to 60° C (2.5 % / ° C)
Mounting height	1000 m, with power loss up to 2000 m (7.5 % / 1000 m)
Relative humidity	15 ... 85 %, condensation is not permitted
Storage temperature	-25° C up to +70° C
Protection/ Connections	IP00, terminals VBG4 / screw terminals
Permissible contamination	P2 acc. to EN 61558-1, vertical wall mounting
UL-Recognition	all motor filters have the UL-Recognition for the markets in USA and Canada
Rotating field frequency/Clock frequency of power stage	max. 150 Hz from 4 up to 8 kHz
Standstill torque (rotating field zero)	max. 5 s, all 120 s
Motor cable length screened	max. 250 m
Output voltage	sinozoidal with low, overlaid ripple voltage

Motor filters						
Techn. data Order code	Suitable for inverter modules	Rated current [A]	Power loss [W]	max. capacitance per unit length of motor cable [pF/m]	Connection cross section [mm ²]	Weight [kg]
MRF34.10	CDA32.004 bis CDA34.010	10	70	L - L = 140 L - Screen = 210	4	5.5
MRF34.17	CDA34.014	16.5	120		10	8.5
MRF34.24	CDA34.024	24	150		16	14.5
MRF34.32	CDA34.032	32	170	L - L = 170 L - Screen = 260	16	19
MRF34.45	CDA34.045	48	190		16	25.5
MRF34.60	CDA34.060	61	220		35	33.5
MRF34.72	CDA34.072	72	250	L - L = 190 L - Screen = 300	35	37
MRF34.90	CDA34.090	90	290		50	53
MRF34.110	CDA34.110	115	350		95	66
MRF34.170	CDA34.143 CDA34.170	180	450		150	75

Motor filter		MRF 34.10	MRF 34.17	MRF 34.24	MRF 34.32	MRF 34.045	MRF 34.060	MRF 34.072	MRF 34.090	MRF 34.110	MRF 34.170
Dimension [mm]											
W (Width)		160	185	280	280	280	315	315	320	415	415
H (Height)		155	190	240	240	240	300	300	300	360	360
D (Depth)		120	160	190	200	220	228	240	270	210	240
D		130	170	190	190	190	240	240	240	264	264
E		71	67	105	105	125	133	145	172	125	154
Fixing screws C		M5	M5	M6	M6	M6	M8	M8	M8	M8	M10
Drawings											

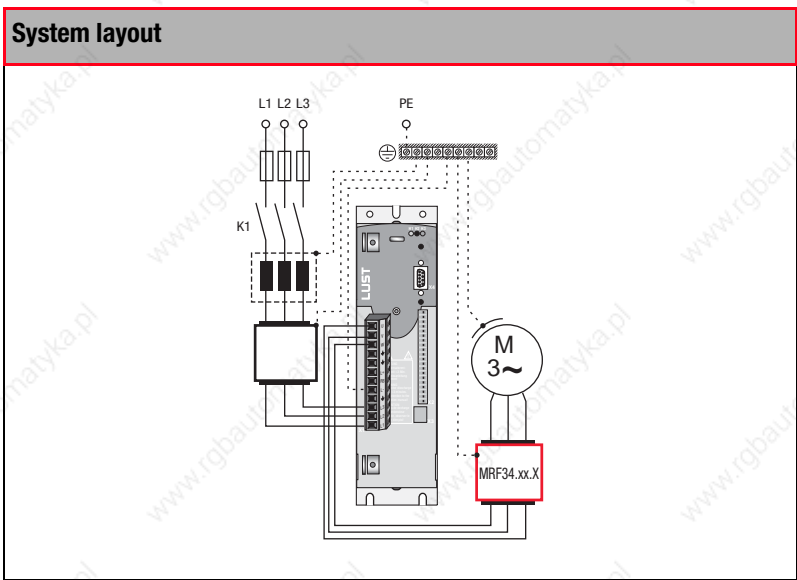

Inverter ED12.005,C for simple applications



Order Code

ED 12 . □□□, □x.x

Type

Technical data

Cooling method

For complete ordering data please refer to the following tables.

Order code	ED12.005
Techn. data	
Output motor side	
Recommended rated power with 4-pole standard motor	0.25 kW up to 0.75 kW
Device rated power	1.4 kVA
Voltage	3 x 0 ... 230 V
Effective rated current (at 4/8 kHz)	3.5 A
Peak current (4/8 kHz) for 10 s	7.0 A
Rotating field frequency	0 ... 400 Hz
Switching frequency of power stage	4, 8 kHz (factory setting 8 kHz at 40° C cooling air temperature)
Input mains side	
Mains voltageq	1 x 230 V -20 % +15 %
Frequency	50/60 Hz ±10 %
Power loss (at 4/8 kHz)	35 W

Order code	ED12.005
Ambient cond.	
Temperature range	
during operation	0 ... 40 °C, with power loss up to 50 °C (2,5 %/°C)
during storage	-25 ... +55 °C
during transport	-25 ... +70 °C
Relative humidity	15 ...85% no condensation
Mechanical strength (IEC68-2-6)	
stationary use	Vibration: 0.075 mm (10 ... 58 Hz) Shock: 9.8 m/s ² (>9 ... 500 Hz)
during transport	Vibration: 3.5 mm (5 ... 9 Hz) Shock: 9.8 m/s ² (>9 ... 500 Hz)
Protection	
Device	IP00 (NEMA 1)
Touch protection	VBG 4
Monting height	up to 1000 m above MSL, with power loss up to max. 2000 m above MSL

Norms/Acceptances	ED12.005
CE-mark	Conform to the requirements of the low voltage directive DIN EN 50178. The inverter is conform to the requirements for installation in a machine or plant under the terms of the Machinery Directive 98/37/EG.
UL-Approbation	The inverter ED1200 is „UL-Recognized“  . It is equivalent to UL and CSA for „UL-Recognized Components“.
EMV-acceptance	By taking the installation notes into consideration (see operation manual) the EMV product norm will EN 61800-3 will be met. Including <ul style="list-style-type: none"> • Public low voltage system: Residential areas up to 10 m motor cable length • Industrial low voltage system: Industrial area up to 25 m motor cable length

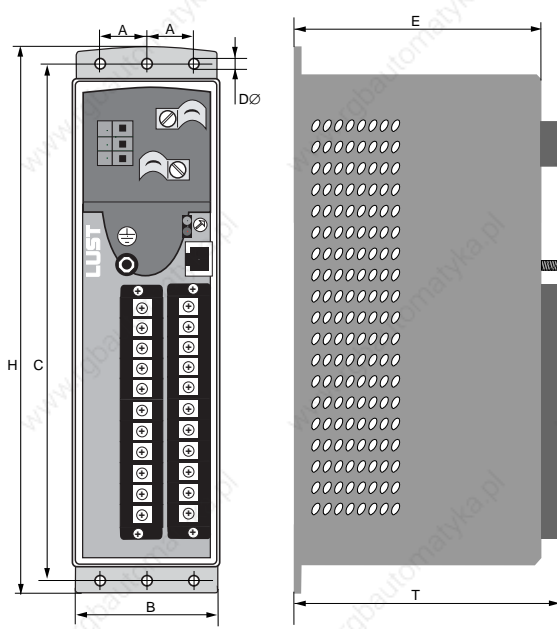
Cooling method	ED12.005, C x.x	Drawing
Mechanics		
Cooling air temperature	40 °C (at 4/8 kHz switching frequency)	
Weight	1.3 kg	
Mounting method	vertical mounting	
Single mounting	Additional cooling via mounting plate (unvarnished) of 0.25 m ²	
Dimensions	[mm]	
W (Width)	65	
H (Height)	233	
D (Depth)	120	
A	20	
C	220	
E	105	
DØ	Ø 4.8	

Order code	Short description
HS12.005	Heat sink for use at thermically insulated mounting areas
ED12.005,C1x.x with HS12.005	Drawing

Order code		Short description
Dimensions	[mm]	
W (Width)	65	
H (Height)	232.5	
D (Depth)	67.5	
A	32.5	
C	246.5	
D	∅ 4.8	
E	256.5	
F	187.5	
Weight	[kg]	
Heat sink	0.9	

User information on paper (selection)



Order Code

0XXX . XXB . X-xx

Docu Id.-No.

Stand

For complete ordering data please refer to the following tables.

User information	Method	Order code	Language
Operating manual CDA3000	Presents the mechanical and electrical installation of the CDA3000 inverter module. Guide to quick and save initial commissioning.	0840.00B.x	German/English/ Frenchh/Italien/ Spain
Application manual CDA3000	Presents the adaptation of the drive system to the application (software-based).	0840.02B.x 0840.22B.x	German English
User manual, communication modules CM-CAN1	Project planning, installation and commissioning of the CDA3000 to field bus CAN _{Lust} .	0916.01B.x 0916.21B.x	German English
User manual, communication modules CM-CAN2	Project planning, installation and commissioning of the CDA3000 to field bus CAN _{open} .	0916.02B.x 0916.22B.x	German English
User manual communication modules CM-DPV1	Project planning, installation and commissioning of the CDA3000 to field bus PROFIBUS-DP.	0916.00B.x 0916.20B.x	German English
CDA3000-PLC System manual	Presents machine sub-automation solutions with c-line DRIVES in connection with VTxxxx Operator Panels	0840.12B.x	German English
ED1200 Operating manual	Presents the mechanical and electrical installation of the ED 12.005,C inverter. Guide to quick and save initial commissioning.	0994.01B.x 0994.21B.x	German English

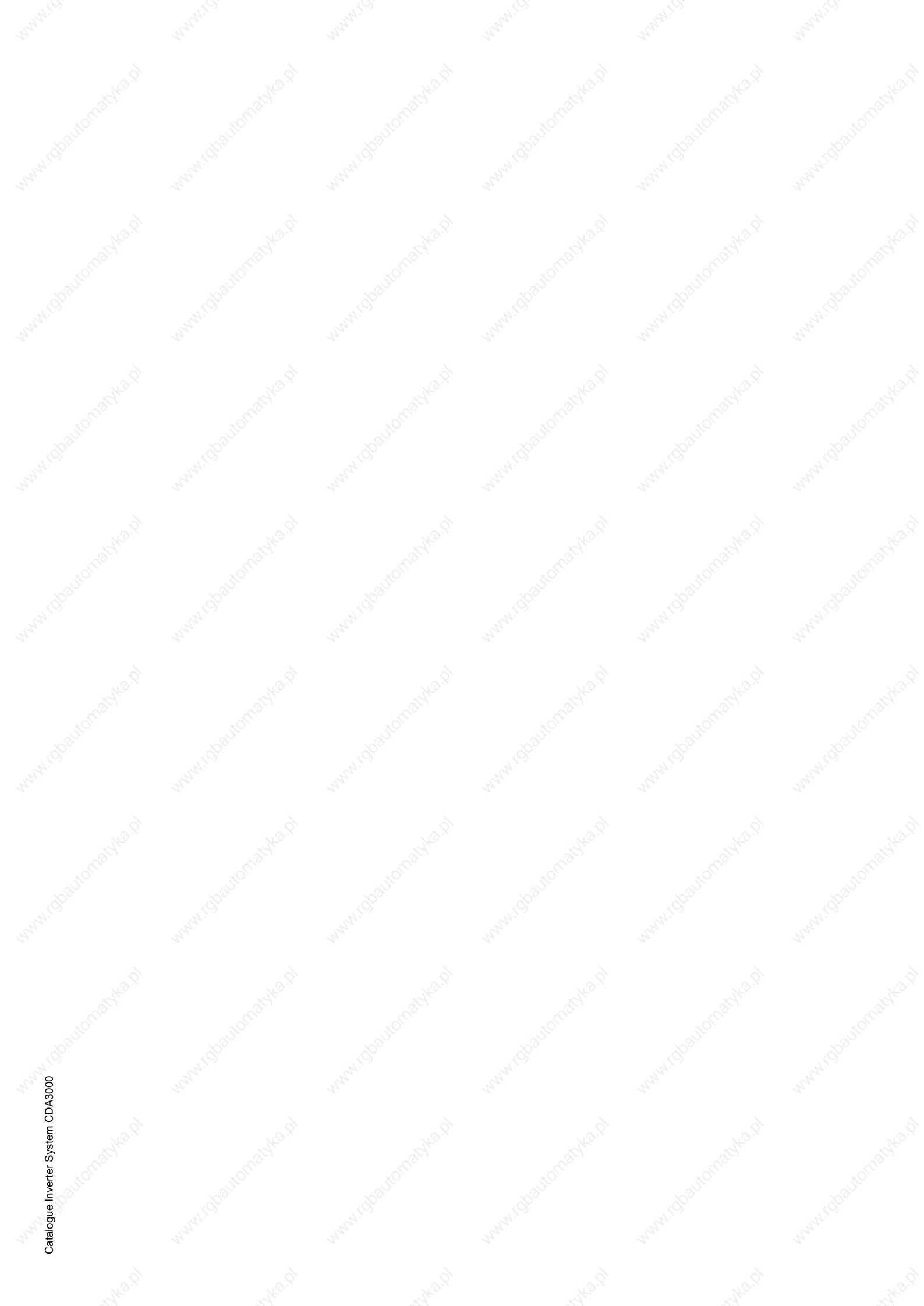



Lust Antriebstechnik GmbH

Gewerbestr. 5-9 • D-35633 Lahnau

Fon: +49 (0) 64 41 / 9 66-0 • Fax: +49 (0) 64 41 / 9 66-137

Internet: <http://www.lust-tec.de> • e-Mail: info@lust-tec.de

Id-No: 0840.24B.4-00 • Date: 01/04

We reserved the right to make technical changes.