

## Technical data

Features at env. 25°C	Description			
Total configurability	From keypad or serial communications, the user selects: type of input - associated functions and corresponding outputs - type of control algorithm - type of output and safe conditions - alarm types and functionality - control parameter values			
PV input (for signal ranges see table 1)	Common characteristics	A/D converter with 50.000 points Update measurement time : 0.2 sec Sampling time : 0.5 sec Input shift: - 60... + 60 digit Input filter : 1...30 sec (OFF= 0)		
	Accuracy	0.25% ± 1 digit (T/C and RTD) 0.1% ± 1 digit (mA and mV)	Between 100 and 240V ~error is minimal	
	Resistance thermometer (for ΔT: R1+R2 must be <320Ω)	Pt100Ω at 0°C (IEC 751) °C/°F selectable	2 or 3 wire connection Burnout (with any combination)	Line: 20 Ω max (3wire) Thermal drift 0.35°C/10°C env. T. <0.35°C/10 Ω line exist.
	Thermocouple	L, J, T, K, S, R, B, N, E, W3, W5 (IEC 584) °C/°F selectable	Internal cold junction compensation with NTC Error 1°C/20°C ± 0.5°C Burnout	Line: 150 Ω max Thermal drift <2µV/°C env. T. <5µV/10 Ω line resist.
	DC input (current)	0/4...20mA, 2.5Ω ext. shunt Rj >10MΩ	Burnout. Engineering units, floating decimal point, configurable	Input drift: <0.1% / 20°C env. T. <5µV/10 Ω line resist.
	DC input (voltage)	0/10...50mV Rj >10MΩ	Low Range -999...9999 High Range -999...9999 100 digits minimum	
Auxiliary inputs	Remote Setpoint (option) Not isolated accuracy 0.1%	Current 0/4...20mA Rj = 30Ω Voltage 1-5/0-5/0-10V Rj = 300KΩ	Bias in engineering units and ± range Ratio from -9.99...+99.99 Local + Remote	
	CT current transformer	50 or 100mA input hardware selectable	Current visualization 10...200 A with 1A resolution and Heater break alarm	
Operating modes	1 single or double action P.I.D. loop or ON/OFF with 1, 2 or 3 alarms			
Control mode	Algorithm	P.I.D. with overshoot control or ON/OFF		
	Proport. band (P)	0.5...999.9%	User Enabled/Disabled	
	Integral time (I)	0.1...100.0 min		
	Derivative time (D)	0.01...10.00 min		
	Error dead band	0.1...10.0 digit		
	Overshoot control	0.01...1.00	Single action PID algorithm	
	Manual reset	0.0...100.0%		
	Cycle time (Time proportional only)	1...200 sec		
	Control output high limit	10.0...100.0%		
	Soft-start output value	0.1...100.0%		User Enabled/Disabled
	Output safety value	0.0...100.0% (-100.0...100.0% for Heat/Cool)	ON/OFF algorithm	
	Control output hysteresis	0.1...10.0%		
	Dead band	-10.0...10.0%		
Relative cool gain	0.1...10.0			
Cycle time (Time proportional only)	1...200 sec	Double action PID algorithm (Heat/Cool) with overlap		
Cool output high limit	10.0...100.0%			
Cool output hysteresis	0.1...10.0%			
OP1-OP2 outputs	SPST relay N.O., 2A/250V~ for resistive load Triac, 1A/250V~ for resistive load			
OP3 output	SPDT relay N.O., 2A/250V~ for resistive load			
OP4 output	SSR drive not isolated: 0/5V-, ± 10%, 30mA max.			

Input type	Scale range
RTD Pt100 IEC751	-99.9...300.0 °C
	-99.9...572.0 °F
RTD Pt100 IEC751	-200...600 °C
	-328...1112 °F
TC L Fe-Const DIN43710	0...600 °C 32...1112 °F
TC J Fe-CU45% NI IEC584	0...600 °C 32...1112 °F
TC T Cu-CuNi	-200...400 °C
	-328...752 °F
TC K Cromel- Alumel IEC584	0...1200 °C 32...2192 °F
TC S Pt10% Rh-Pt IEC584	0...1600 °C 32...2912 °F
TC R Pt13% Rh Pt IEC584	0...1600 °C 32...2912 °F
TC B Pt30% Rh Pt 6% IEC584	0...1800 °C 32...3272 °F
TC N Nicrosil- Nisil IEC584	0...1200 °C 32...2192 °F
TC E Ni10% CR CuNi IEC584	0...600 °C 32...1112 °F
TC Ni-NiMo18%	0...1100 °C 32...2012 °F
TC W3%Re W25%Re	0...2000 °C 32...3632 °F
TC W5%Re W26%Re	0...2000 °C 32...3632 °F
0/4...20 mA 0/10...50 mV mV Custom scale	Configurable engineering units mA, mV, V, bar, psi, Rh, ph On request

Table 1: PV input

## Special functions

To improve the instrument performance and to reduce the wiring and installation costs, two special functions are available:

### - Start-up

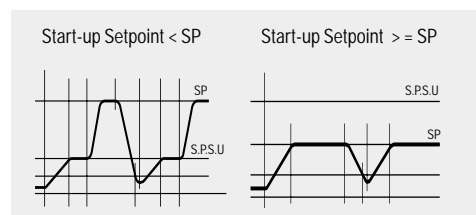

### - Timer

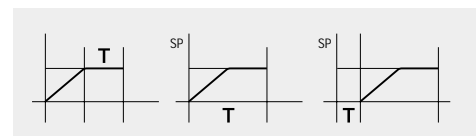

The use of these functions avoids additional device installation (e.g. external timer), therefore allowing a significant costs reduction.

Moreover there are:

- **Keypad lock/unlock** function, to avoid incorrect operator actions
- **Outputs lock/unlock** function, at any moment it is possible to stop the control action, but not the process variable display, without switching-off the power supply.

## Technical data

Features at env. 25°C	Description		
OP5 (option) analogue output	PV/SP retransmission	Galvanically isolated: 500V~ /1min Resolution: 12 bit Accuracy: 0.1%	In current: 0/4...20mA, 750Ω /15V max
AL1- AL2 - AL3 alarms	Hysteresis	0.1...10.0%	
	Action	Active high	Action type
		Active low	Deviation threshold ± range
		Special functions	Band threshold 0...range
		Absolute threshold, whole range	
		Sensor break, Heater break and Loop break detection	
		Acknowledge (latching), activation inhibit (blocking)	
		Connected to Timer or program (if options installed)	
Setpoint	Local	Up and down ramps 0.1...999.9 digit/min.	
	Local plus two stored (tracking or Stand-by)	(OFF=0)	
	Local and Remote	Low limit:	
	Local with trim	High limit:	
	Remote with trim	If option installed	from low range to high limit
Special functions (options)	Timer	Automatic start at the power on, manual start by keypad or serial comm.s	
	Start-up	Setting time: 1...9999 sec/min	
		Stand-by Setpoint: from Setpoint low limit to Setpoint high limit	
One-shot Fuzzy-Tuning	Depending on the process condition, the controller applies the best method	Step response	Natural frequency
Serial comm.s (option)	RS 485 isolated, Modbus/Jbus protocol 1200, 2400, 4800, 9600 bit/sec, three wires		
Auxiliary power supply	+24V- ±20%, 30 mA max for external transmitter supply		
Operational safety	Measure input	Detection of out of range, short circuit or sensor break with automatic activation of the safety strategies and alerts on display	
	Control output	Safety value: -100%...100%	
	Parameters	A non volatile memory stores for unlimited time all the configuration and parameter values	
	Password	Password to access the configuration and parameters data, keypad lock, outputs lock	
General characteristics	Power supply (fuse protected)	100-240~ (-15% + 10%) 50/60Hz or 24~ (-15% + 25%) 50/60Hz and 24V- (analogue) (-15% + 25%)	Power consumption 4W max
	Safety	Compliance EN61010-1 (IEC 1010-1), installation class 2 (2500V), pollution class 2, class II instrument	
	Electromagnetic compatibility	Compliance to the CE standards for industrial system and equipment	
	Approval UL and cUL	File E176452	
	Protection EN60529 (IEC529)	IP65 front panel	
Dimensions	1/8 DIN - 48 x 96, depth 110 mm, weight 250g appr.		

## Electrical wirings

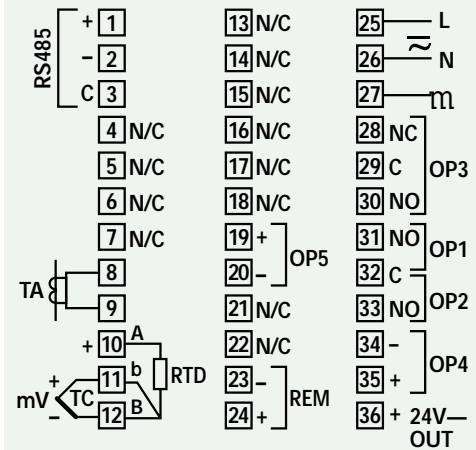

## Fuzzy-Tuning

Two methods of tuning are available:

- **Auto-Tuning "one shot"**
- **Natural frequency "one shot"**

The **Fuzzy-Tuning** automatically selects one of the two methods which assure the best result for each condition.

The **Auto-Tuning** method works best on the step response basis.

When activated, if a deviation exists between the Setpoint and process variable larger than 5% of scale range, the controller modifies the output value. Then, in a short time, it calculates the PID parameters and the new algorithm is operational immediately.

The main advantages of this method are fast calculation and quick implementation.

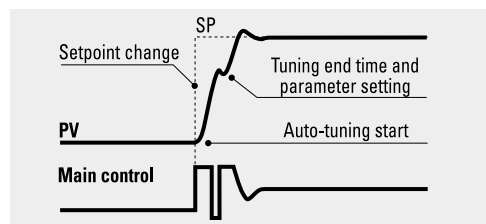

The **Natural frequency** method works best when the process variable is very near to the Setpoint. When activated, it causes a process oscillation around the Setpoint value.

The main advantage of this method is a reduced disturbance to the process.

