



WITTENSTEIN

motion control

TPM⁺ power

Control Techniques Unidrive SP

Quick Startup Guide

Revision history

Revision	Date	Comment	Chapter
01	08.07.2009	First release	All
02	14.04.2010	Completion TPM+ Power 050 / 110	5

Service

In case you have technical questions,
please contact:

WITTENSTEIN motion control GmbH

Customer Service

Walter-Wittenstein-Straße 1

D-97999 Igersheim

Tel.: +49 (0) 79 31 / 493- 10900

Fax: +49 (0) 79 31 / 493- 10903

E-Mail: service-wmc@wittenstein.de

© WITTENSTEIN motion control GmbH 2010

This documentation is copyright protected.

WITTENSTEIN motion control GmbH reserves all the rights to photo-mechanical reproduction, copying, and the distribution by special processes (such as computers, file media, data networks), even in parts.

Subject to technical and content changes without notice.

1 Table of Contents

1	Table of Contents	2
2	General Information	3
2.1	Description, designations	3
2.2	Whom does this manual concern?	3
2.3	Which signs and symbols are referred to in this manual?	3
2.4	Exclusion of liability	3
2.5	EC low-voltage directive / EMC regulations	3
2.6	Copyright	3
3	Safety	4
3.1	Intended use	4
3.2	Improper use	4
3.3	Safety Instructions	4
3.3.1	General safety instructions	4
4	Type plate information – identification	6
4.1	Identification plate, designation	6
5	Setting the parameters	7
5.1	TPM+ motor feedback Resolver	7
5.2	TPM+ motor feedback Heidenhain EnDat	7
5.3	TPM+ motor feedback Sick-Stegmann Hiperface	8
5.4	TPM+ power 560 V – Ratio 4 – 35	9
5.5	TPM+ power 560 V – Ratio 40 – 100	10
5.6	TPM+ power 320 V – Ratio 4 – 35	11
5.7	TPM+ power 320 V – Ratio 40 – 100	12
6	Connection schematic TPM+ power	13
6.1	TPM+ power with resolver	13
6.2	TPM+ power with absolute encoder Heidenhain EnDat ECN1113 / EQN 1125	14
6.3	TPM+ power with absolute encoder Stegmann SKS 36 / SKM 36	15

2 General Information

2.1 Description, designations

The AC servo actuator **TPM⁺** (hereafter referred to as servo actuator) is a combination of a low-backlash planetary gearhead and an AC servo motor.

The following manual contains the following points:

- Safety Instructions
- Parameter lists for the **TPM⁺** series
- Connection schematic for **TPM⁺**

2.2 Whom does this manual concern?

This manual concerns all persons who install, operate, or maintain this servo actuator.

They may only carry out work on the servo actuator, if they have read and understood this operating manual. Please pass the safety instructions on to other persons as well.

2.3 Which signs and symbols are referred to in this manual?

- ➔ An “action instruction”, which requires you to carry out an action.
- ▽ With a “check” you can specify whether the device is ready for the next work stage.
- ☺ A “usage tip” shows you an option of facilitating or improving operations.

The safety instructions symbols are described in section [3 “Safety”](#).

2.4 Exclusion of liability

WITTENSTEIN motion control is not liable for damages or injury caused by:

- Improper utilization of the servo actuator and the servo amplifier or
- Incorrect setting of operating parameters.

2.5 EC low-voltage directive / EMC regulations

The servo actuator has been constructed in accordance with EC directive 73/23/EEC.

During installation and connection of the electrical components, the relevant regulations have to be observed (for example wire cross sections, fuse protection, etc.).

Meeting all requirements for the entire system is the responsibility of the system's manufacturer. You may only operate the equipment if you comply to the national EMC regulations (refer to the servo amplifier documentation for installation information pertaining to EMC) as they are defined for the given application.

2.6 Copyright

© 2009, **WITTENSTEIN motion control GmbH**

All of the product brand names which appear in this manual are trademarks of the relevant companies. If the ® and/or ™ symbols are omitted, this does imply that the name is a free brand name.

3 Safety

3.1 Intended use

The servo actuator is designed for industrial applications. Its purpose is to drive machines. Please refer to our catalogue or our Internet page for the maximum permitted speeds and torques: www.w-m-c.de.

- ➡ Please consult our technical service if your servo actuator is more than a year old. In this way you receive valid data.
- ➡ Please be sure to read the documentation provided by the manufacturer of the servo actuator.

3.2 Improper use

Any use transgressing the above-named restrictions (especially higher torques and speeds) is not compliant with the regulations, and is thus prohibited.

The operation of the servo actuator is prohibited if:

- It was not installed according to regulations (for example fastening bolts).
- The servo actuator is very dirty, damaged or blocked.
- It is operated without lubricant.
- The cables are damaged or improperly connected.
- The operating parameters have not been set properly.

3.3 Safety Instructions

The following symbols are used in this manual to warn you of hazards:



DANGER!

This symbol warns you of danger of injury to yourself and others.



Attention

This symbol warns you of the risk of damage to the servo actuator.



Environment

This symbol warns of environmental pollution risk.

3.3.1 General safety instructions

Working on the servo actuator



DANGER!

Improperly executed work can lead to injury and damage.

- ➡ Always ensure that the servo actuator is only installed, maintained, and dismantled by trained technicians.

**DANGER!**

Current-flow through the body or arcing can lead to grave injury and death.

- Only perform tasks on the electrical system if you are:
 - A trained electrician.
 - A person trained in electro-technology, working under the supervision of a specialist electrician.
- Always adhere to the five safety rules for the de-energised state:
 - De-energise.
 - Secure against being turned on (for example by locking it).
 - Ensure that de-energised state exists.
 - Attach ground line and short-circuit the equipment.
 - Cover and safeguard any live parts in the immediate vicinity.

**DANGER!**

Impurities spinning through the air can cause grave injury.

- Before putting the servo actuator into operation, check that there are no impurities or tools near it.

Maintenance**DANGER!**

An unintentional start of the machine during maintenance work can lead to serious accidents.

- Ensure that no one can start the machine while you are working on it.

**DANGER!**

Even only briefly running the machine during maintenance work can lead to accidents if the safety devices are not operating.

- Check that all safety devices have been mounted and are activated.

Wiring**DANGER!**

Incorrect wiring can lead to injuries and damage.

- Only use power and signal cables recommended by WITTENSTEIN motion control.
- Do not cut off power and signal cables, and do not insert extensions.
- Make sure that the U-U, V-V and W-W motor phases are correctly connected.
- Make sure that the motor encoder interface of the servo controller is compatible to the servo actuator.
- Observe the prescribed voltage for the brakes (usually 24 V DC) and the polarity.

4 Type plate information – identification

- ➔ The technical specifications can be found on your servo actuator's type plate according to the following scheme.

4.1 Identification plate, designation

The following specifications can be found on the identification plate:

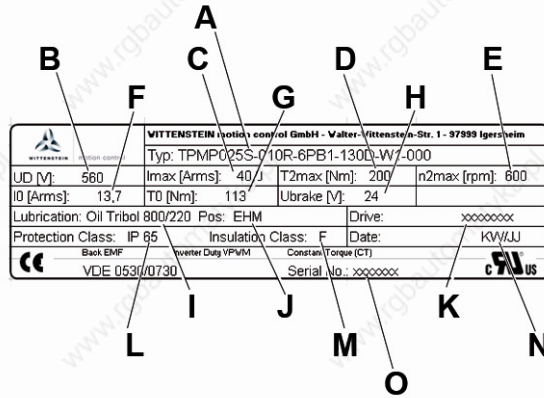

- A Ordering code
- B DC-Bus voltage
- C Maximum current
- D Maximum torque at gear output
- E Maximum gear output speed
- F Continuous stall current
- G Continuous stall torque at gear output
- H Brake voltage
- I Lubricant
- J Mounting position
- K For use with drive
- L Type of protection
- M Insulation class
- N Manufacturing date
- O Serial number

Bild 4.2

Designation:

TPM 010S-110R -6PB1-055S-W1

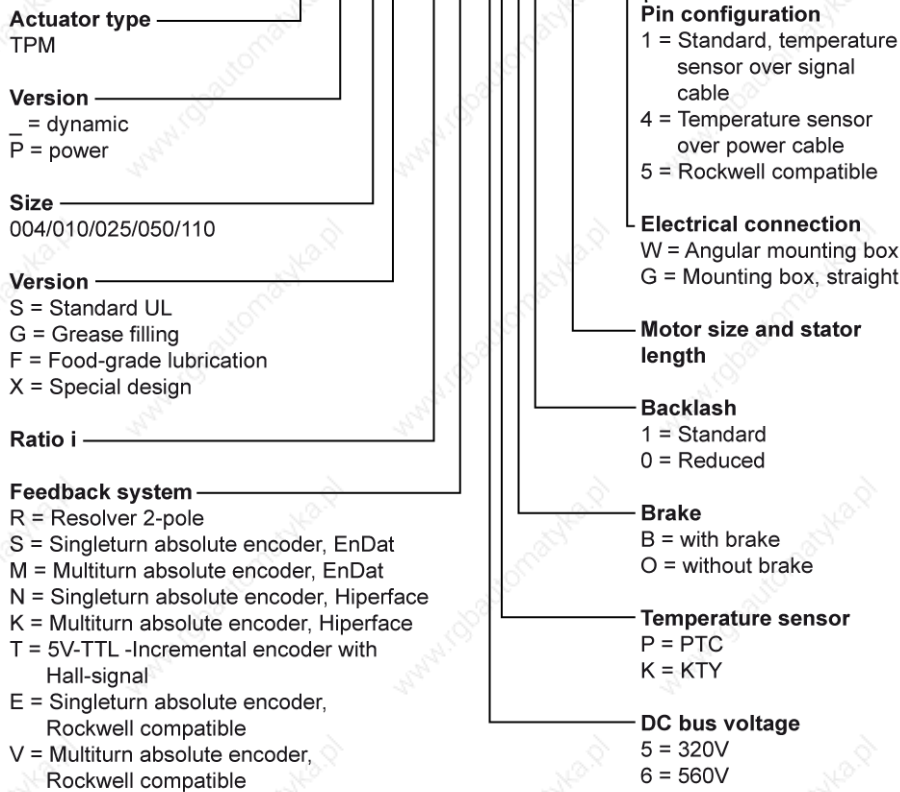

5 Setting the parameters

The tables in chapter 5 contain all of the parameters that are required for the initial start-up of a **TPM⁺ power** servo actuator from WITTENSTEIN motion control at a servo drive **Control Techniques Unidrive SP**.

When the servo actuator and the servo drive are properly connected, these parameters guarantee that the servo actuator can be operated at idle with speed control.

Based on these default settings, you can optimize the dynamics of the speed controller depending on the application.

Follow the details of the type plate.

Data for combinations not shown here are available on demand.

5.1 TPM⁺ motor feedback Resolver

The parameter of the motor feedback has to be entered before connecting the motor.

Wrong parameters can damage the motor feedback or the drive.

Parameter	Function	Unit	TPM 004S	TPM 010S	TPM 025S	TPM 050S	TPM 110S	
03.26	Speed feedback selector		Slot 1, Slot 2 or Slot 3 depending on slot for SM-Resolver					
03.40	Drive encoder error detection level		0	0	0	0	0	
xx.10	Equivalent lines per revolution		1024	1024	1024	1024	1024	
xx.13	Resolver excitation		1 (2:1)	1 (2:1)	1 (2:1)	1 (2:1)	1 (2:1)	
xx.15	Resolver poles		2Poles (0)	2Poles (0)	2Poles (0)	2Poles (0)	2Poles (0)	
00.43	Encoder phase angle	°	180	180	180	180	180	

5.2 TPM⁺ motor feedback Heidenhain EnDat

The parameter of the motor feedback has to be entered before connecting the motor.

Wrong parameters can damage the motor feedback or the drive.

Parameter	Function	Unit	TPM 004S	TPM 010S	TPM 025S	TPM 050S	TPM 110S	
03.26	Speed feedback selector		drv (0)					
03.36	Drive encoder supply voltage		5V	5V	5V	5V	5V	
03.38	Drive encoder type		SC.EnDat	SC.EnDat	SC.EnDat	SC.EnDat	SC.EnDat	
03.41	Drive encoder auto-configuration		ON (1)	ON (1)	ON (1)	ON (1)	ON (1)	
00.43	Encoder phase angle	°	180	180	180	180	180	



5.3 TPM+ motor feedback Sick-Stegmann Hiperface

The parameter of the motor feedback has to be entered before connecting the motor.
Wrong parameters can damage the motor feedback or the drive.

Parameter	Function	Unit	TPM 004S	TPM 010S	TPM 025S	TPM 050S	TPM 110S	
03.26	Speed feedback selector		drv (0)					
03.36	Drive encoder supply voltage		8V	8V	8V	8V	8V	
03.38	Drive encoder type		SC.Hiper	SC.Hiper	SC.Hiper	SC.Hiper	SC.Hiper	
03.41	Drive encoder auto-configuration		ON (1)	ON (1)	ON (1)	ON (1)	ON (1)	
00.43	Encoder phase angle	°	120	120	120	120	120	

5.4 TPM⁺ power 560 V – Ratio 4 – 35

Par.	Description	Unit	TPMP004S	TPMP010S	TPMP025S	TPMP050S	TPMP110S
0,07	Speed controller proportional gain (Kp1)	1/rad s ⁻¹	0,005	0,005	0,01	0,01	0,01
0,08	Speed controller integral gain (Ki1)	1/rad	1	1	1	1	1
0,09	Speed controller differential feedback gain (Kd1)	s	0,00	0,00	0,00	0,00	0,00
0.38 ¹	Current controller Kp gain	-	See note 1				
0.39 ¹	Current controller Ki gain	-	See note 1				
0,41	Maximum switching frequency	kHz	16	16	16	16	16
0,42	Number of motor poles	-	8	12	12	12	12
0,46	Motor rated current	Arms	1,56	5,40	13,70	19,00	38,60
0,48	Operating mode selector	-	SERVO	SERVO	SERVO	SERVO	SERVO
1,06	Maximum reference clamp	RPM	6000	6000	6000	5000	5000
4.05 ²	Motoring current limit	%	333	315	292	334	259
4.06 ²	Regen current limit	%	333	315	292	334	259
4.07 ²	Symmetrical current limit	%	333	315	292	334	259
4,15	Thermal time constant	s	100	200	400	400	400
4,16	Thermal protection mode	-	1 or 0 depending on application				
5,08	Rated Speed	RPM	6000	6000	6000	5000	5000
5,17	Stator resistance	Ohm	21,30	2,20	0,45	0,27	0,08
5,24	Transient inductance (Ls)	mH	22,80	6,00	3,00	2,10	0,90
5,32	Motor torque per amp, Kt	Nm/Arms	0,97	0,98	1,00	1,19	1,09
7,15	T8 analogue input 3 mode	-	th	th	th	th	th

¹ Automatic calculation by setting #0.40 to 6 after input of R and L in #5.17 and 5.24.

² Subject to static and dynamic loads as well as the lambda factor the max. acceleration motor current has to be reduced. We recommend a detailed calculation with Cymex.

5.5 TPM+ power 560 V – Ratio 40 – 100

Par.	Description	Unit	TPMP004S	TPMP010S	TPMP025S	TPMP050S	TPMP110S
0,07	Speed controller proportional gain (Kp1)	1/rad s-1	0,005	0,005	0,01	0,01	0,01
0,08	Speed controller integral gain (Ki1)	1/rad	1	1	1	1	1
0,09	Speed controller differential feedback gain (Kd1)	s	0,00	0,00	0,00	0,00	0,00
0.38 ¹	Current controller Kp gain	-	See note 1				
0.39 ¹	Current controller Ki gain	-	See note 1				
0,41	Maximum switching frequency	kHz	16	16	16	16	16
0,42	Number of motor poles	-	8	12	12	12	12
0,46	Motor rated current	Arms	1,00	1,86	4,00	7,50	21,90
0,48	Operating mode selector	-	SERVO	SERVO	SERVO	SERVO	SERVO
1,06	Maximum reference clamp	RPM	6000	6000	6000	5000	5000
4.05 ²	Motoring current limit	%	300	323	300	440	228
4.06 ²	Regen current limit	%	300	323	300	440	228
4.07 ²	Symmetrical current limit	%	300	323	300	440	228
4,15	Thermal time constant	s	100	200	400	400	400
4,16	Thermal protection mode	-	1 or 0 depending on application				
5,08	Rated Speed	RPM	6000	6000	6000	5000	5000
5,17	Stator resistance	Ohm	40,00	13,50	4,00	1,81	0,25
5,24	Transient inductance (Ls)	mH	30,00	18,90	11,10	5,10	1,90
5,32	Motor torque per amp, Kt	Nm/Arms	0,78	1,02	0,97	0,91	1,08
7,15	T8 analogue input 3 mode	-	th	th	th	th	th

¹ Automatic calculation by setting #0.40 to 6 after input of R and L in #5.17 and 5.24.

² Subject to static and dynamic loads as well as the lambda factor the max. acceleration motor current has to be reduced. We recommend a detailed calculation with Cymex.

5.6 TPM⁺ power 320 V – Ratio 4 – 35

Par.	Description	Unit	TPMP004S	TPMP010S	TPMP025S
0,07	Speed controller proportional gain (Kp1)	1/rad s-1	0,005	0,005	0,01
0,08	Speed controller integral gain (Ki1)	1/rad	1,00	1,00	1,00
0,09	Speed controller differential feedback gain (Kd1)	s	0	0	0
0.38 ¹	Current controller Kp gain	-	See note 1		
0.39 ¹	Current controller Ki gain	-	See note 1		
0,41	Maximum switching frequency	kHz	16	16	16
0,42	Number of motor poles	-	8	12	12
0,46	Motor rated current	Arms	2,70	9,35	23,73
0,48	Operating mode selector	-	SERVO	SERVO	SERVO
1,06	Maximum reference clamp	RPM	6000	6000	6000
4.05 ²	Motoring current limit	%	333	314	295
4.06 ²	Regen current limit	%	333	314	295
4.07 ²	Symmetrical current limit	%	333	314	295
4,15	Thermal time constant	s	100	200	400
4,16	Thermal protection mode	-	1 or 0 depending on application		
5,08	Rated Speed	RPM	6000	6000	6000
5,17	Stator resistance	Ohm	7,10	0,73	0,13
5,24	Transient inductance (Ls)	mH	7,33	2,00	1,00
5,32	Motor torque per amp, Kt	Nm/Arms	0,56	0,56	0,58
7,15	T8 analogue input 3 mode	-	th	th	th

¹ Automatic calculation by setting #0.40 to 6 after input of R and L in #5.17 and 5.24.

² Subject to static and dynamic loads as well as the lambda factor the max. acceleration motor current has to be reduced. We recommend a detailed calculation with Cymex.

5.7 TPM+ power 320 V – Ratio 40 – 100

Par.	Description	Unit	TPMP004S	TPMP010S	TPMP025S
0,07	Speed controller proportional gain (Kp1)	1/rad s-1	0,005	0,005	0,01
0,08	Speed controller integral gain (Ki1)	1/rad	1,00	1,00	1,00
0,09	Speed controller differential feedback gain (Kd1)	s	0	0	0
0.38 ¹	Current controller Kp gain	-	See note 1		
0.39 ¹	Current controller Ki gain	-	See note 1		
0,41	Maximum switching frequency	kHz	16	16	16
0,42	Number of motor poles	-	8	12	12
0,46	Motor rated current	Arms	1,73	3,22	6,93
0,48	Operating mode selector	-	SERVO	SERVO	SERVO
1,06	Maximum reference clamp	RPM	6000	6000	6000
4.05 ²	Motoring current limit	%	300	323	303
4.06 ²	Regen current limit	%	300	323	303
4.07 ²	Symmetrical current limit	%	300	323	303
4,15	Thermal time constant	s	100	200	400
4,16	Thermal protection mode	-	1 or 0 depending on application		
5,08	Rated Speed	RPM	6000	6000	6000
5,17	Stator resistance	Ohm	13,30	4,50	1,33
5,24	Transient inductance (Ls)	mH	10,00	6,30	3,70
5,32	Motor torque per amp, Kt	Nm/Arms	0,45	0,59	0,56
7,15	T8 analogue input 3 mode	-	th	th	th

¹ Automatic calculation by setting #0.40 to 6 after input of R and L in #5.17 and 5.24.

² Subject to static and dynamic loads as well as the lambda factor the max. acceleration motor current has to be reduced. We recommend a detailed calculation with Cymex.

6 Connection schematic TPM+ power

- ➔ Detailed information on cable design and the type of shielding can be found in the documentation from the servo drive manufacturer.

6.1 TPM+ power with resolver

WITTENSTEIN motion control offers pre-manufactured and drag chain compatible cablesets for this servo drive. Please take the required order informations from the TPM+ catalogue.

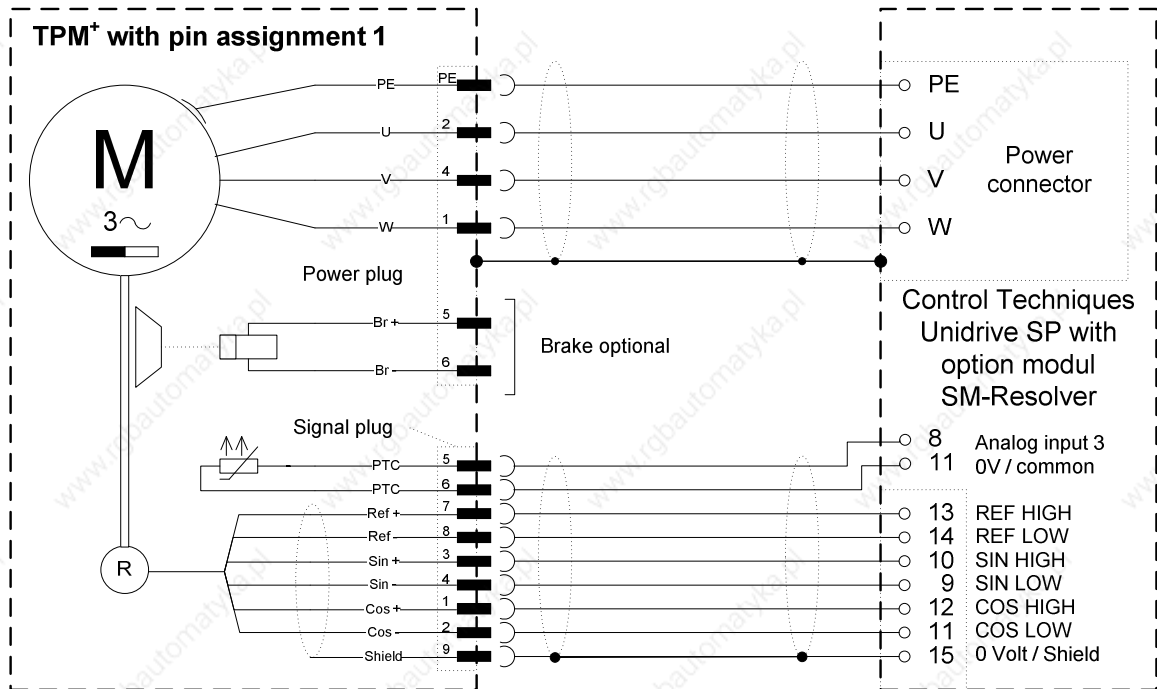

6.2 TPM+ power with absolute encoder Heidenhain EnDat ECN1113 / EQN 1125

WITTENSTEIN motion control offers pre-manufactured and drag chain compatible cables for this servo drive. Please take the required order informations from the TPM+ catalogue.

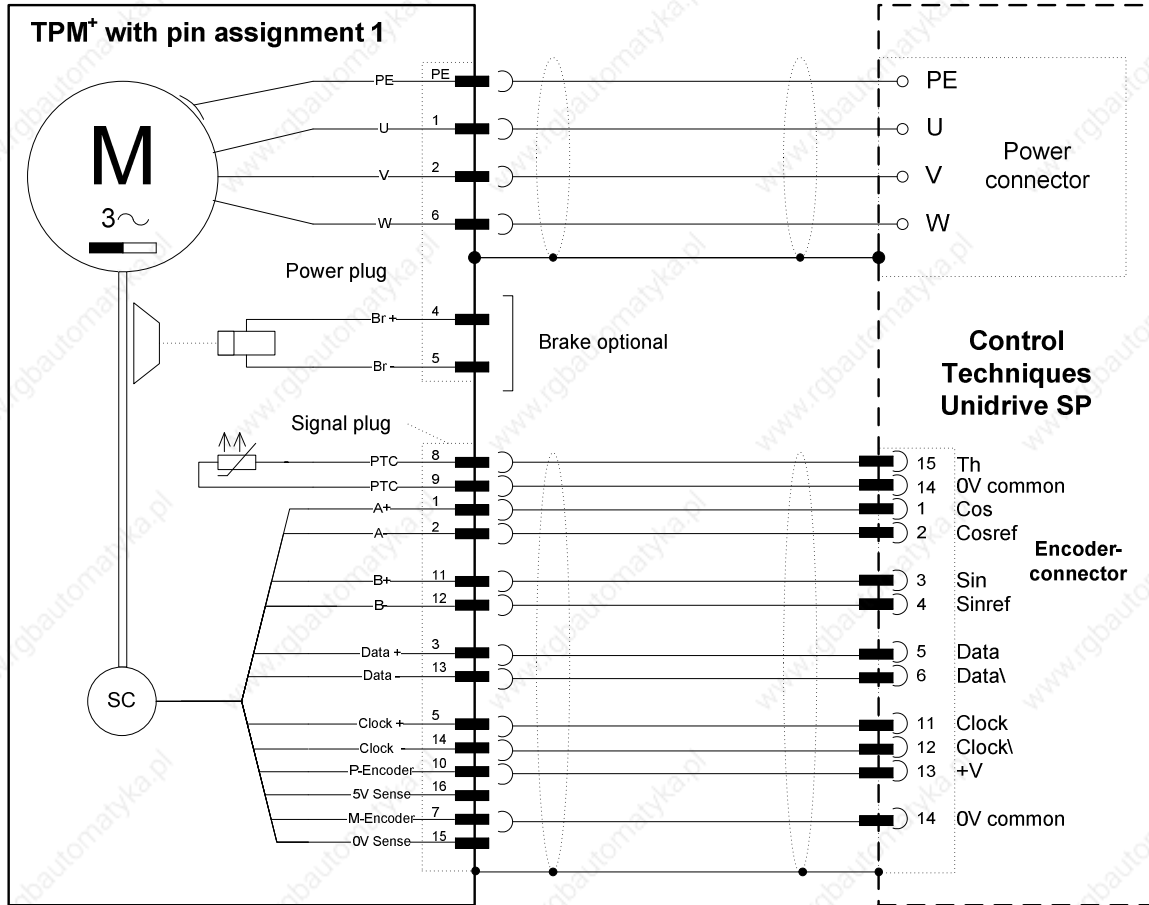

6.3 TPM+ power with absolute encoder Stegmann SKS 36 / SKM 36

WITTENSTEIN motion control offers pre-manufactured and drag chain compatible cablesets for this servo drive. Please take the required order informations from the TPM+ catalogue.

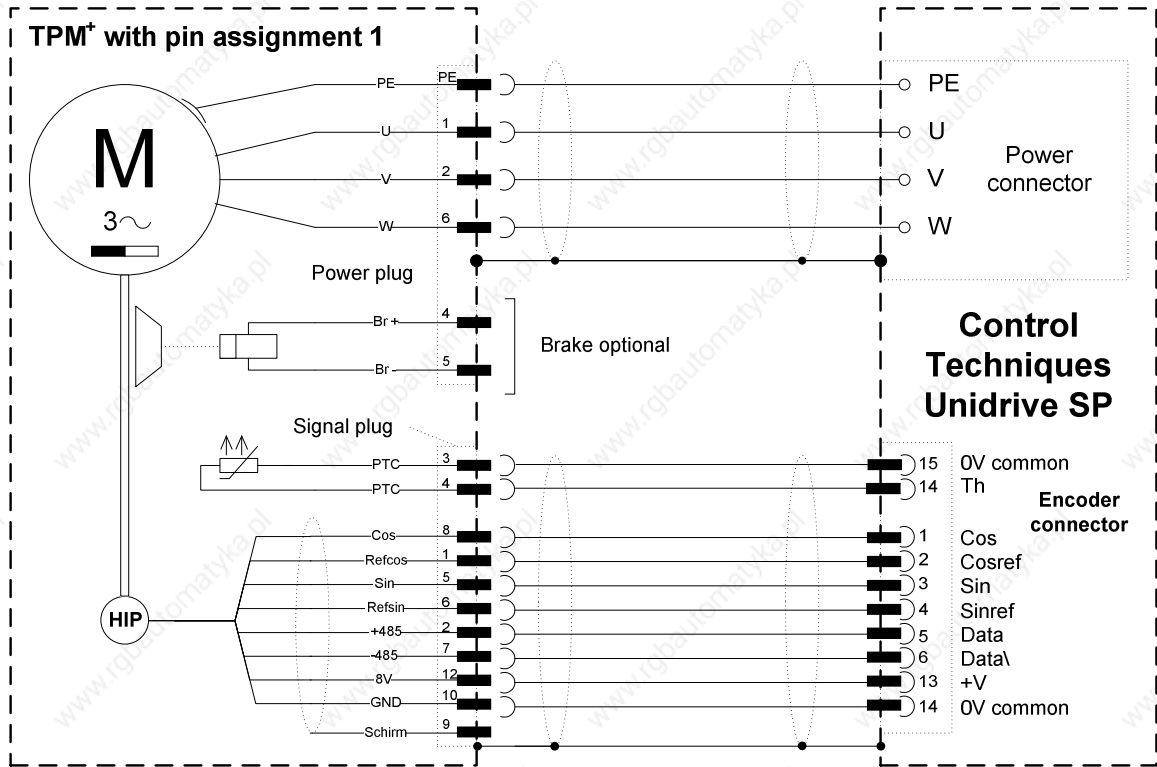



WITTENSTEIN

motion control

WITTENSTEIN motion control GmbH
Walter-Wittenstein-Straße 1
97999 Igersheim

WITTENSTEIN - being one with the future

www.wittenstein.de