

MINI-BEAM SM31E/R Opposed Mode Sensors

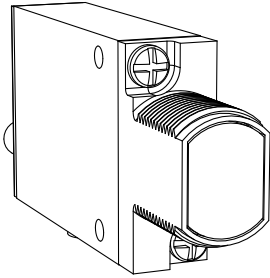

Datasheet



- Compact, self-contained opposed mode modulated infrared sensor pairs for 10 to 30 V dc operation
- Standard sensor pairs have 3 m (10 ft) range; long range sensor pairs have 30 m (100 ft) range
- Switch-selectable for light operate or dark operate; highly repeatable, 1 millisecond response
- Both sourcing and sinking outputs (150 mA maximum each)
- Receivers include Banner's exclusive AID™ alignment system, US patent number 4356393
- Rugged, epoxy-encapsulated construction: meets NEMA standards 1, 2, 3, 3S, 4, 4X, 6, 12, and 13, IEC IP67
- Physically and electrically interchangeable with 18 mm barrel-type photoelectrics



WARNING: Not To Be Used for Personnel Protection

Never use this device as a sensing device for personnel protection. Doing so could lead to serious injury or death. This device does not include the self-checking redundant circuitry necessary to allow its use in personnel safety applications. A sensor failure or malfunction can cause either an energized or de-energized sensor output condition.

Models ¹ ²	Range	Cable	Excess Gain	Beam Pattern
SM31E (Emitter) SM31R (Receiver) SM31EQD (Emitter) SM31ROD (Receiver)	3 m (10 ft)	2 m (6.5 ft) 4-Pin Euro QD		
SM31EL (Emitter) SM31RL (Receiver) SM31ELQD (Emitter) SM31RLQD (Receiver)	30 m (100 ft)	2 m (6.5 ft) 4-Pin Euro QD		

¹ To order the 9 m (30 ft) cable models, add the suffix "W/30" to the model number of any cabled sensor (e.g., SM31EL W/30). To order the 150 mm (6 inch) long pigtail cable with attached QD connector models, add the suffix "QDP" to the model number of any MINI-BEAM sensor (e.g., SM31ELQDP). Models with a QD connector require an accessory mating cable.

² To order emitters and receivers with 0.3 millisecond on/off response, add the suffix "MHS" to the model numbers (e.g., SM31EMHS & SM31RMHS). This modification reduces sensing range (and excess gain).



Installation and Alignment

Proper operation of the sensors requires they be mounted securely and aligned properly. Excessive movement or vibration can cause intermittent or false operation due to loss of alignment. For maximum mechanical stability, final-mount these sensors in 18-mm holes by their threaded barrels or use a mounting bracket .

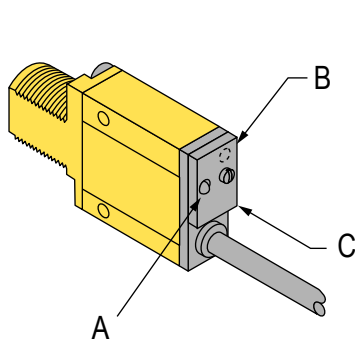

Figure 1. Receiver Adjustments

A - "AID" Indicator LED lights when the sensor sees the reflection of its own modulated light and pulses at a rate proportional to the strength of the received light signal

B - 15 turn gain adjustment and light/dark operate switch

C - Gasketed acrylic cover

Regarding the light/dark operate switch:

- Turn switch fully clockwise for light operate (sensor outputs conduct when sensing light is received)
- Turn switch fully counterclockwise for dark operate (sensor outputs conduct when sensing light is not received)

1) Begin with the emitter mounted securely in place. For small-parts counting applications, stretch a string between the emitter and receiver lenses to ensure the sensing beam passes through the center of the sensing location. For less critical applications, the receiver may be initially positioned by line-of-sight placement. Mount the receiver, leaving a means for movement.

2) Apply power to the emitter and receiver, and advance the receiver's 15-turn GAIN control to maximum (clockwise end of rotation). The GAIN control is clutched at both ends to avoid damage and will "free-wheel" when either endpoint is reached.

If the receiver is "seeing" the emitter's light beam, the receiver alignment LED is on. Move the receiver up-down-right-left (include angular rotation) to obtain the fastest receiver LED pulse rate. If a pulse is not observable (too fast to count), reduce the GAIN control (counterclockwise rotation) to obtain a countable pulse rate of one to five beats per second. Note: to aid alignment at short ranges, it may help to further reduce the strength of the light signal by temporarily masking the emitter and/or receiver lens with tape or a sheet of paper.

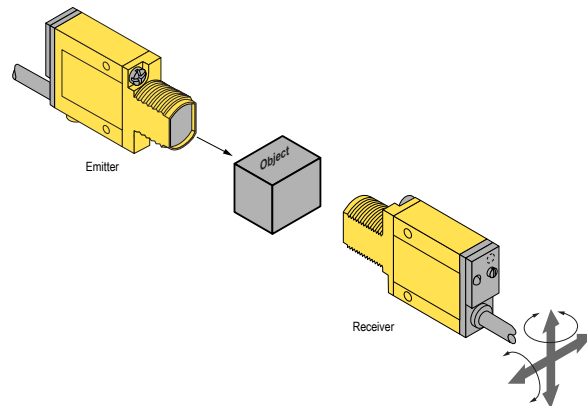

Figure 2. Opposed Mode Alignment. Move the receiver to obtain the fastest LED pulse rate.

3) Repeat the alignment motions after each GAIN reduction. When you have found the receiver orientation that produces the fastest pulse rate, mount the receiver solidly in that position. Remove any masking material, and increase the receiver GAIN to maximum. Test the system by placing the object to be detected into the sensing position. The receiver LED indicator should go off. If it does not go off, the cause is probably either "flooding" or "burn-through".

Flooding occurs when a portion of the effective beam passes around the object to be sensed and activates the receiver. Check that the object completely breaks the beam and that the beam is centered on the object. Add apertures, if necessary, to tailor the effective beam to the size or profile of the object being sensed. Burn-through refers to a portion of the emitter's light energy passing through a thin or translucent object and activating the receiver. Try sensing at a reduced GAIN setting or consider an alternative sensing scheme.