

### Electrical & Optical Specifications (Ta=25C) :

Parameter	Symbol	Min.	Typ.	Max.	Units	Conditions
Supply Current	I <sub>CC</sub>		230		μA	LUX=1K, V <sub>CC</sub> =3V
Photo Current output (I)	I <sub>PH1</sub>	21	30	39	uA	Lux=1K, V <sub>CC</sub> =3V (Note 1,3)
Photo Current output (II)	I <sub>PH2</sub>		36			Lux=1K, V <sub>CC</sub> =3V (Note 2,3)
Light Current Ratio	I <sub>PH2</sub> /I <sub>PH1</sub>		1.2			
Rise Time	Tr		0.2		mSec	Rload = 27K ohms, 1K lux, V <sub>CC</sub> = 3V
Fall Time	Tf		0.2		mSec	Rload = 27K ohms, 1K lux, V <sub>CC</sub> = 3V
Peak sensitivity wavelength	λ		560		nm	
SD Current	I <sub>CC-SD</sub>			1	μA	V <sub>CC</sub> =3V, SD=3V
Output Compliance Voltage	V <sub>out</sub>	V <sub>CC</sub> -0.5			Volts	RLoad=100K, V <sub>CC</sub> =3V (Refer Figure 7)

Notes :

1. White LED is used as light source
2. Illuminance by incandescent lamp
3. Photo Current (I out) = 10uA x Log (Lux)

### Functional Block Diagram

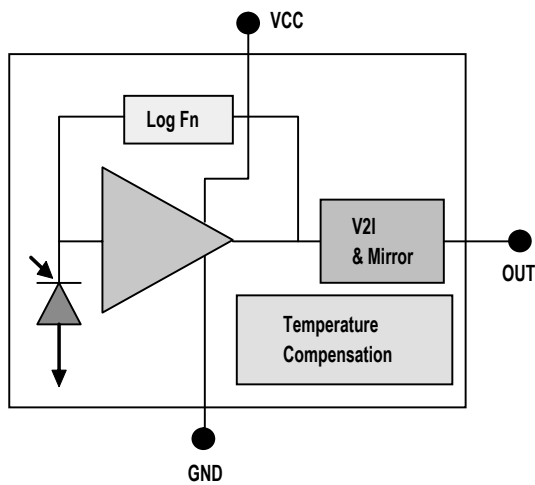

### Light Measurement Circuit and Waveforms

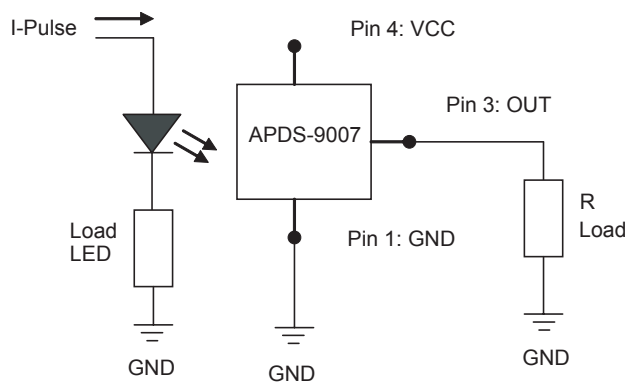

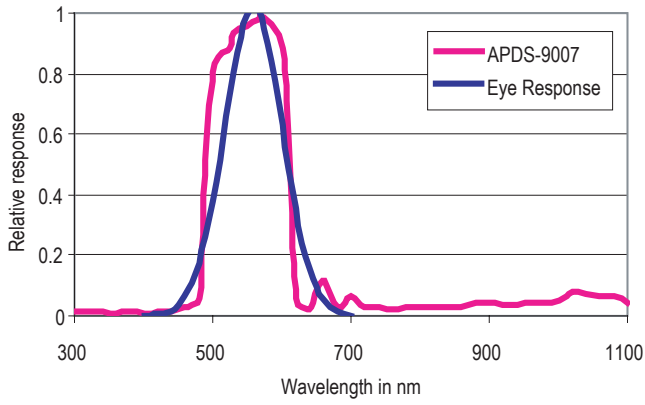

Figure 1. Spectral Response

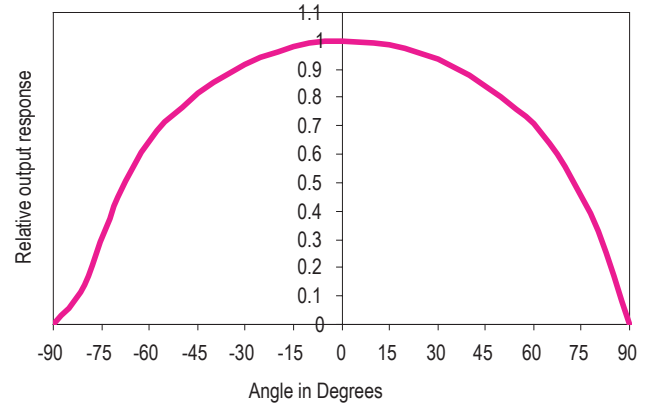

Figure 2. Angular Response plot

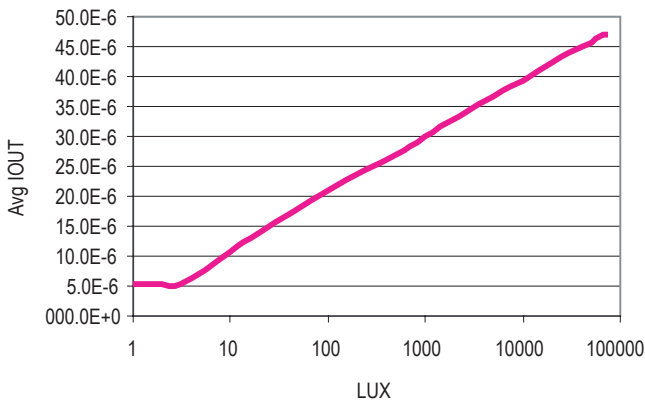

Figure 3. Average Iout vs Lux, T=25°C

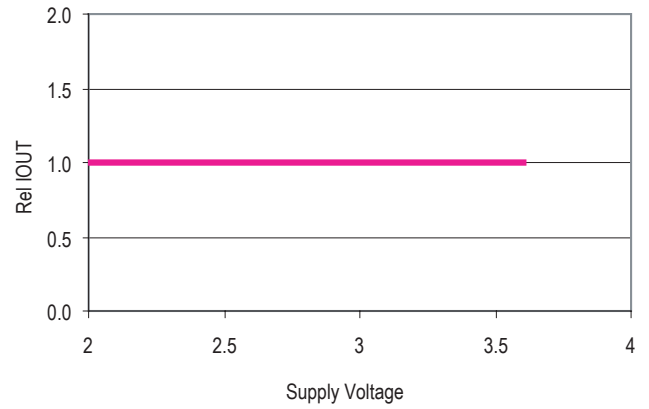

Figure 4. Relative Iout Vs Vcc @ 1K LUX, T=25°C

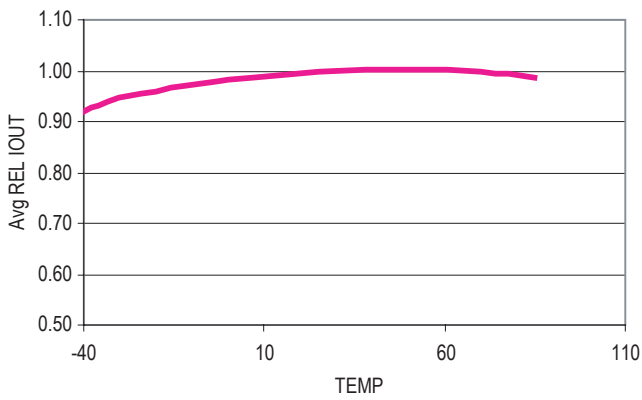

Figure 5. Relative Iout Vs Temperature

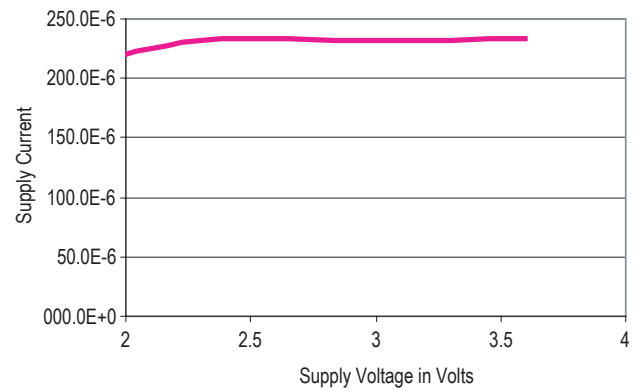

Figure 6. Icc Vs Vcc, T=25°C