

LED Indicators

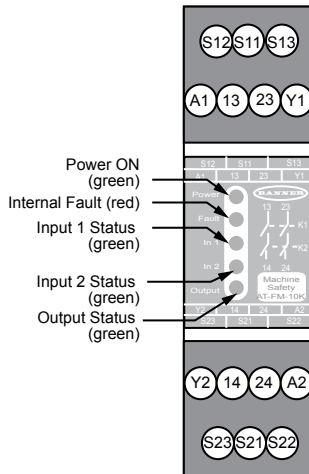

Figure 1. Status indicators and terminal locations

LED	ON	OFF	Flashing
Power ON	Power is applied	No power	—
Fault	Simultaneity is not met or External wiring fault	—	Internal fault condition is detected
Input 1 Status Input 2 Status	Touch button is activated	Button is not activated	External wiring fault is detected
Output Status	Both relays (K1 and K2) are energized	—	Feedback error

Module Operation



CAUTION: Not an Anti-Repeat Control Device

Anti-repeat control is not a function of this Two-Hand Control Safety Module. The user of this device must provide a suitable means of accomplishing anti-repeat control for any single-stroke or single-cycle machine.

The Two-Hand Control Safety Module may be used as an initiation device for most powered machinery when machine cycling is controlled by a machine operator.

Using a two-hand control system makes the operator a “hostage” while the hazard is present, thus limiting or preventing exposure to the hazard. The two-hand control actuators must be located in a way that hazardous motion is completed or stopped before the operator can release one or both of the buttons and reach the hazard (see Separation Distance).

The Safety Module’s safety inputs are used to monitor the actuation of the hand controls to comply with the functionality of Type III requirements of IEC60204-1 and ISO 13851 (Type IIIa/Cat 4) and the requirements of ANSI NFPA79 and ANSI B11.19 for two-hand control, which include:

- Concurrent (simultaneous) actuation by both hands within a 500 ms time frame
- Where this time limit is exceeded, a requirement that both hand controls must be released before operation is initiated
- Continuous actuation during hazardous condition
- Cessation of hazardous condition if either hand control was released
- Release and re-actuation of both hand controls to re-initiate the hazardous motion or condition (i.e., “anti-tie down”)
- The appropriate performance level of the safety-related function (e.g., Control Reliability, Category/Performance Level, or SIL) as determined by a risk assessment or the applicable regulation and standards.

In addition, the Safety Module logic will not permit the safety outputs to turn ON when power is initially supplied and if the hand controls (actuators) are in their Run state (e.g. both actuators tie-down). The hand controls must change to their Stop state and return to the Run state before the safety outputs can turn ON.

The actuating devices must be protected from accidental or unintended operation. This can be accomplished by their mounting position and/or through the use of protective shields such as rings, guards or shields; see Mechanical Installation.

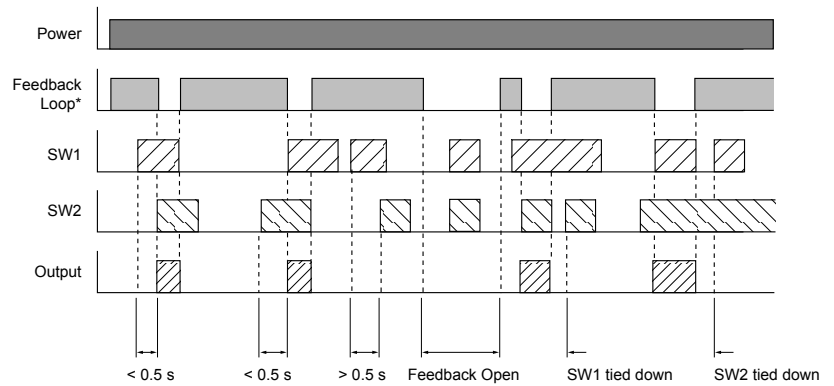

Figure 2. Model AT-FM-10K timing logic

Part- and Full-Revolution Clutched Machinery

When used on **part-revolution clutched machinery** that can be stopped at any point during the cycle, the Safety Module can be used for the following function types: “inch” (jog), “single-stroke,” or “continuous” (run).

When used on **full-revolution clutched machinery** (that can not be stopped until the end of the cycle), the Safety Module is used to *initiate* the cycle and is known as a “two-hand trip device.”

In either situation, the hand controls must be safely located and protected from false operation (see Mechanical Installation and Separation Distance) and the Safety Module must be appropriately interfaced to the machine (see Electrical Installation).

When used in single-cycle or single-stroke mode, the machine control must provide an anti-repeat feature so that the operator must release the two-hand control actuators after each machine cycle, before a new cycle can be initiated.



NOTE: Two-hand control and two-hand trip safeguarding protect **only the operator's hands**. Additional safeguarding (e.g., additional two-hand controls) may be required. **Refer to the relevant standards for additional requirements.**

Mechanical Installation

Install the Safety Module inside an enclosure rated **NEMA 3 (IEC IP54), or better**. It is not designed for exposed wiring. The Module mounts directly onto a standard 35 mm DIN rail.

Heat Dissipation Considerations

For reliable operation, ensure that the operating specifications are not exceeded. The enclosure must provide adequate heat dissipation, so that the air closely surrounding the Module does not exceed the maximum operating temperature stated in the Specifications. Methods to reduce heat build-up include venting, forced airflow (e.g., exhaust fans), adequate enclosure exterior surface area, and spacing between modules and other sources of heat.

Installation of Hand Controls



CAUTION: Hand Controls

The environment in which hand controls are installed must not adversely affect the means of actuation. Severe contamination or other environmental influences may cause slow response or false ON conditions of mechanical or ergonomic buttons. **This may result in exposure to a hazard.**



CAUTION: Install Hand Controls to Prevent Accidental Actuation

Total protection for the two-hand control system from “defeat” is not possible. However, **the user is required by OSHA regulations to arrange and protect hand controls to minimize possibility of defeat or accidental actuation.**