

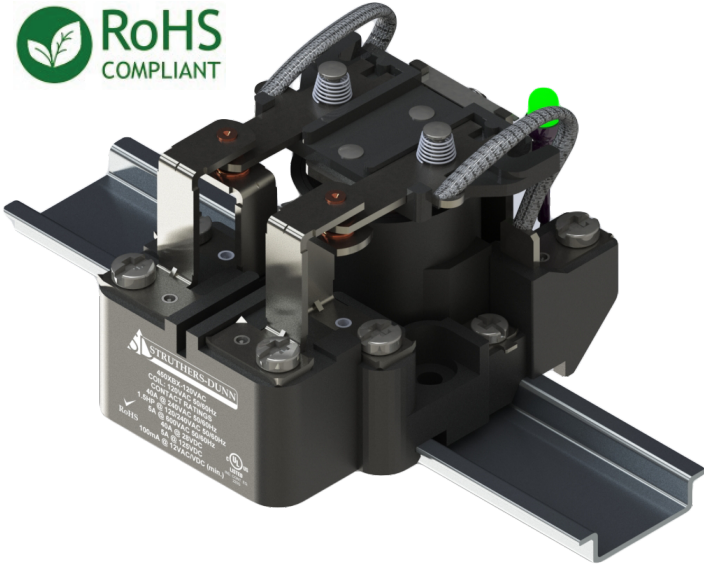

450 SERIES HEAVY DUTY POWER RELAY



- UL Standard 60947-1 (UL 508) Qualified
- Standard Base with DIN Rail and Panel Mount Option
- 10,000,000 Cycles Mechanical and 100,000 Cycles Electrical
- Optional LED - Coil Power Indication
- Optional Polycarbonate Protective Cover
- Class F (155°C) Insulation System
- Max. Rating: 40 Amps or 50 Amps
 - 40 Amps @ 277 VAC - 50 Amps @ 240VAC
 - 40 Amps @ 28 VDC - 50 Amps @ 28VDC



GENERAL CHARACTERISTICS

Insulation System	Class F (155°C)	
Mechanical Life	10,000,000 operations	
Electrical Life	100,000 operations	
Operate Time	20ms	
Release Time	15ms	
Dielectric	Between coil and contact	2200VAC
	Between poles	2200VAC
	Between contacts	1500VAC
Ambient Temperature	AC Coil	-55°C to 70°C
	DC Coil	-55°C to 105°C
Connection	Listed wire connectors required for UL Listed Installations	
Weight	227-311 g	

INPUT CHARACTERISTICS

Rated Voltage	6, 12, 24, 120, 208, 220, 240, 277, 480VAC 6, 12, 24, 48, 110/125, 250VDC
Operating Range	AC: 85% to 110% of Rated Voltage DC: 80% to 110% of Rated Voltage
Dropout Voltage	10% of Rated Voltage
Insulation Resistance	1000 MΩ @ 500VDC

COIL CHARACTERISTICS

Nominal Voltage	Power Consumption	Coil Resistance
6 VAC	~10VA	0.85Ω
12VAC		2.85Ω
24VAC		12Ω
120VAC		290Ω
208VAC		850Ω
220VAC		1040Ω
240VAC		1200Ω
277VAC	1500Ω	
480VAC	4500Ω	
6VDC	~2W	18Ω
12VDC		70Ω
24VDC		290Ω
48VDC		1200Ω
110/125VDC		6000Ω
250VDC		34000Ω

*Additional Coil Voltages Available Upon Request

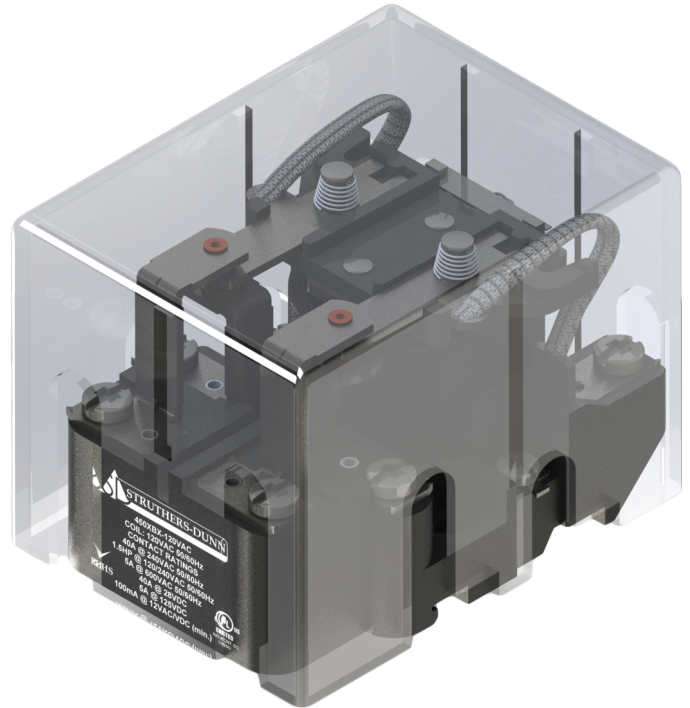

CONTACT CHARACTERISTICS

Configurations	XAX (SPDT) (1 Form C); XBX (DPDT) (2 Form C); BXX (DPST) (2 Form A); HXX (SPST-NO-DM) (Form X); XXH (SPST-NC-DB) (Form Y); XHX (SPDT-DM-DB) (Form Z)	
Contact Material:	AgSnO ₂ - Silver Tin Oxide	
AC Rating:	40A	50A
	40A @ 277VAC 50/60Hz 20A @ 600VAC 50/60Hz 30A @ 120VAC (Ballast) 15A @ 240VAC (Ballast)	50A @ 240VAC 50/60Hz 10A @ 600VAC 50/60Hz
Motor Load Rating:	2HP @ 120/240VAC 50/60Hz	2HP @ 120/240VAC 50/60Hz
DC Rating (With Blowout Magnet):	40A @ 28VDC	50A @ 28VDC
	20A @ 125VDC	20A @ 125VDC
	4A @ 250VDC	4A @ 250VDC
	1A @ 500VDC	2A @ 500VDC
Minimum Load Rating:	100mA @ 12 VAC/DC (min.)	100mA @ 12 VAC/DC (min.)
Auxiliary Switch Rating:	10A @ 125/250VAC	10A @ 125/250VAC
Pilot Duty:	A300	A300
Certifications:	UL/CUL Listed, UL/CUL Recognized	

*Tungsten Contacts Also Available

STRUTHERS-DUNN

www.struthers-dunn.com

407 E. Smith Street - Suite B • Timmonsville, SC 29161 • Phone: (843) 346-4427 • Fax: (843) 346-4465 • Email: info@struthers-dunn.com



450 SERIES HEAVY DUTY POWER RELAY

SPECIAL FEATURES

*Optional Auxiliary Switch - (Code "90")
*Dual Auxiliary Switch Available - (Code "91")

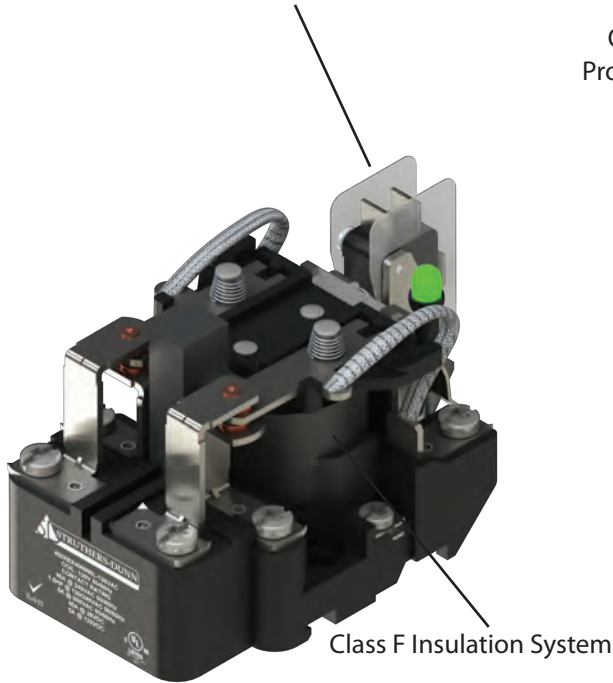

Optional Polycarbonate Protective Cover - (Code "C")

Optional Coil Suppression Diode - (Code "V")
(DC Version Only)

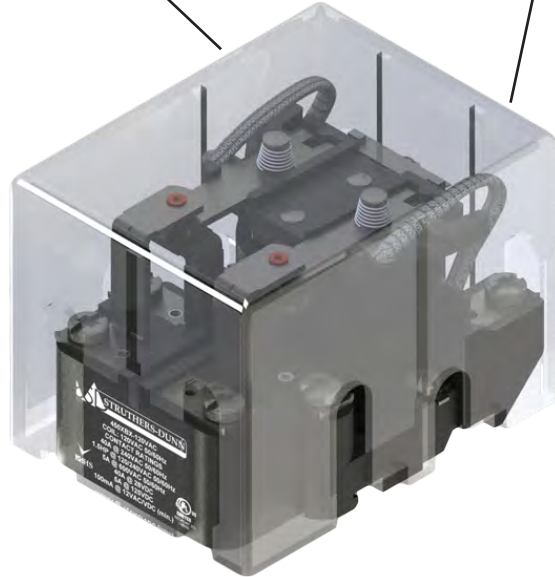

Optional Blowout Magnet - (Code "69")
(Not Available with XXH Contact Combination)

Optional Green LED Indicator - (Code "L")

*Optional Quick Connect Terminals - (Code "Q")

Standard Din Rail & Panel Mount Combination

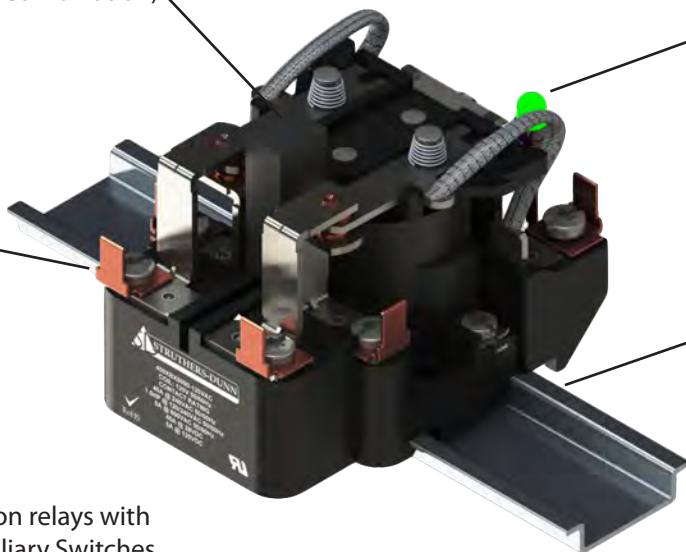

*Note: Covers can not be used on relays with Quick Connect Terminals or Auxiliary Switches