

REFERENCE DATA

1. Max. switching capacity (AC resistive load)

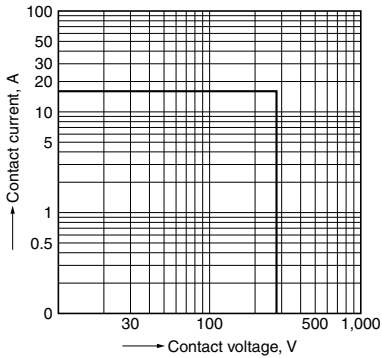

2. Coil temperature rise (Ave.)

Tested sample: ALZN1F12, 6pcs.
Contact current: 16A
Ambient temperature: Normal temperature • 85°C
185°F • 105°C 221°F
Measured portion: inside the coil

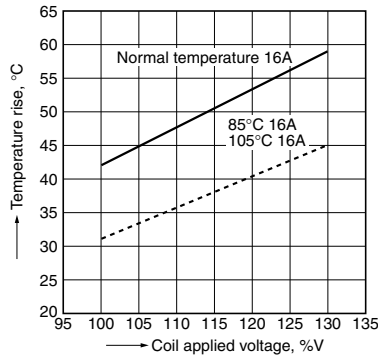

3. Ambient temperature characteristics (Ave.)

Tested sample: ALZN1F12, 6pcs.
Contact carrying current: 0A, 16A
Measured portion: inside the coil

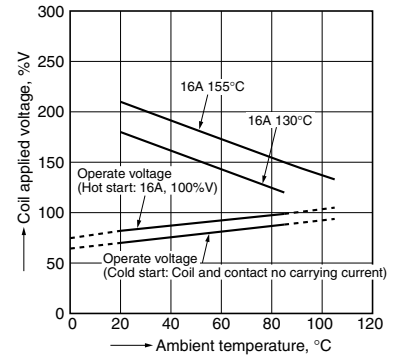

DIMENSIONS (mm inch)

The CAD data of the products with a **CAD** mark can be downloaded from: <http://industrial.panasonic.com/ac/e/>

1. 1 Form A type

CAD



External dimensions

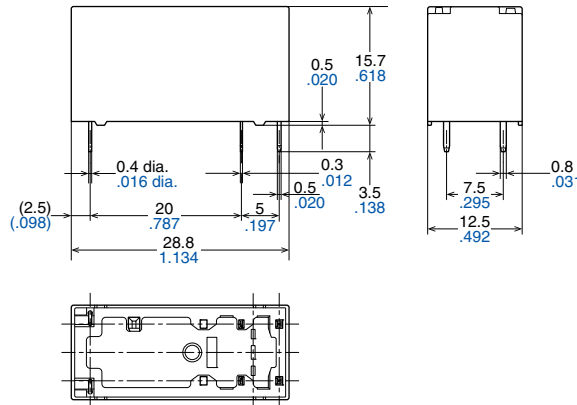

PC board pattern

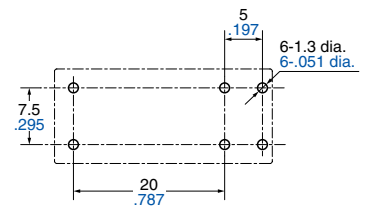

Tolerance: $\pm 0.1 \pm 0.04$

Schematic (Bottom view)

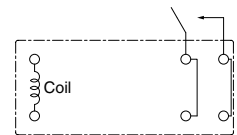

Dimension:
Less than 1mm **.039inch**:
Min. 1mm **.039inch** less than 3mm **.118 inch**:
Min. 3mm **.118 inch**:

Tolerance
 $\pm 0.1 \pm 0.04$
 $\pm 0.2 \pm 0.08$
 $\pm 0.3 \pm 0.12$

2. 1 Form C type

CAD



External dimensions

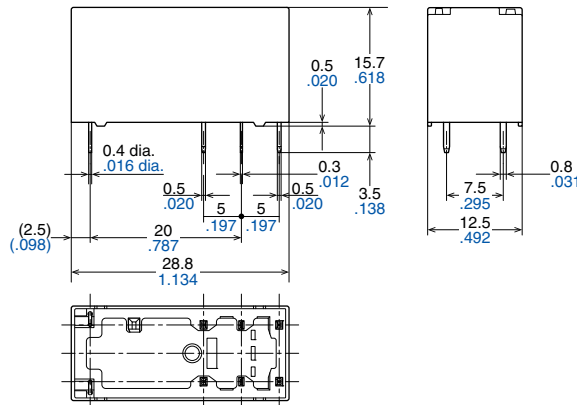

PC board pattern

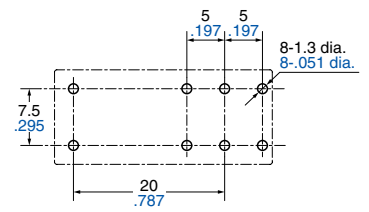

Tolerance: $\pm 0.1 \pm 0.04$

Schematic (Bottom view)

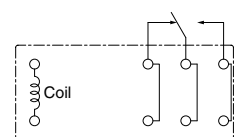

Dimension:
Less than 1mm **.039inch**:
Min. 1mm **.039inch** less than 3mm **.118 inch**:
Min. 3mm **.118 inch**:

Tolerance
 $\pm 0.1 \pm 0.04$
 $\pm 0.2 \pm 0.08$
 $\pm 0.3 \pm 0.12$

SAFETY STANDARDS

UL/C-UL and VDE in process

NOTES

1. For cautions for use, please read “GENERAL APPLICATION GUIDELINES”.