

EX-20 SERIES Ver.2

Related Information

- General terms and conditions..... F-7
- Sensor selection guide P.271~
- Glossary of terms / General precautions .P.1455~ / P.1458~
- Korea's S-mark..... P.1506



panasonic.net/id/pidsx/global



Miniature-sized and still mountable with M3 screws

Miniaturization by using single chip optical IC

The beam-receiving photodiode and the A/D conversion circuit have been fabricated on a single chip optical IC (full custom). Hence, in spite of its miniature size, it has a performance and reliability which is equal to or better than the conventional product.

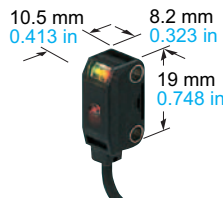

Incorporates a sensitivity adjuster even in this size

The sensor incorporates a sensitivity adjuster in spite of its miniature size. It is convenient when you need fine adjustment. Further, the receiver of the thru-beam, side sensing type sensor incorporates an operation mode switch which can change the output operation.



BASIC PERFORMANCE

Long sensing range

The EX-20 series achieves long distance sensing [thru-beam type: 2 m **6.562 ft**, retroreflective type: 200 mm **7.874 in** (when using the attached reflector), diffuse reflective type: 160 mm **6.299 in**], despite its miniature size. Hence, it is usable even on a wide conveyor.

Thru-beam type

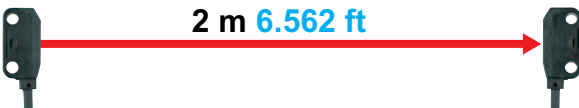

Retroreflective type

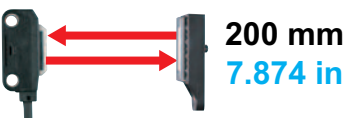

Diffuse reflective type



Clear beam spot using red LED dot light source

The emission area of a dot light source is smaller than that of a conventional LED flat light source, and it is possible to design a high power, narrow beam. Since a red LED dot light source is used, the red beam spot is clear even at a far place, so that alignment and confirmation of sensing position is easy. Further, since the thru-beam type, too, incorporates a visible narrow beam, it can also reliably detect small parts, such as, chip components, lead frames, etc.

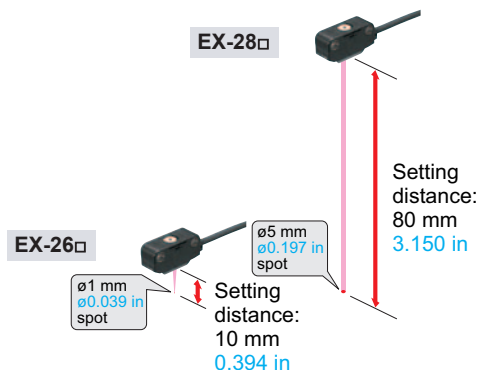

Selection Guide
Amplifier Built-in
Power Supply Built-in
Amplifier-separated

CX-400
CY-100
EX-10
EX-20
EX-30
EX-40
CX-440
EQ-30
EQ-500
MQ-W
RX-LS200
RX
RT-610

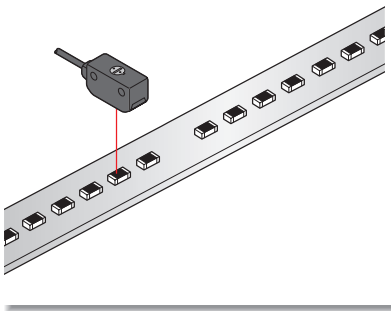
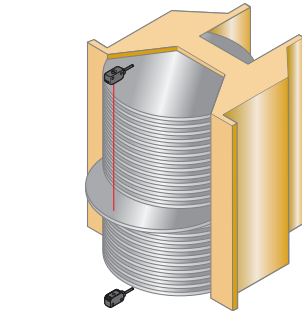
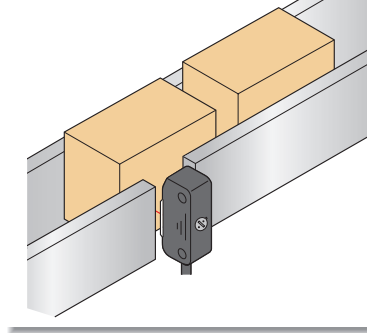
APPLICATIONS**Detecting presence of chip components****Checking protrusion of wafer****Sensing objects from an opening****BASIC PERFORMANCE****Electric power saving***

The EX-20 series achieves reductions in power consumption of up to 65%. These sensors contribute to environmental friendliness.

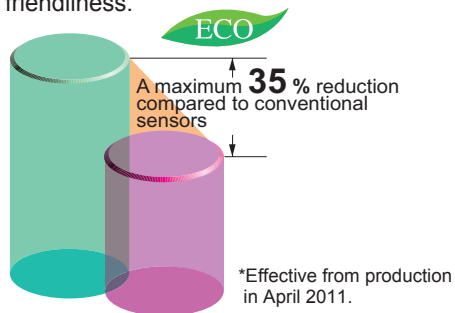
**ENVIRONMENTAL RESISTANCE****Waterproof IP67 (IEC)**

The sensor can be hosed down because of its IP67 construction. Further, the sensor mounting bracket is also made of stainless steel.

Note: However, take care that if it is exposed to water splashes during operation, it may detect a water drop itself.

Incorporated an inverter countermeasure circuit*

The EX-20 series become significantly stronger against inverter light and other extraneous light.

*Effective from production in April 2011.

MOUNTING**Identical size**

Front sensing type of thru-beam type and diffuse reflective type sensors have identical appearance. Moreover, since the mounting holes are symmetrical with respect to the beam axis center, the design becomes easy.

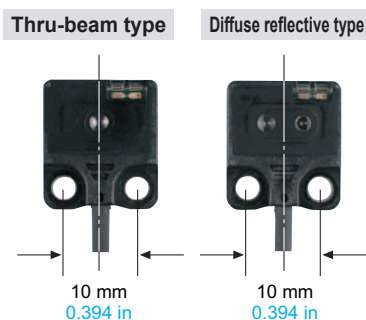
**Mounting section reinforced**

It can be tightened with M3 screws. Moreover, metal inserts have been provided in the mounting holes so that the product is not damaged even in case of excess tightening.

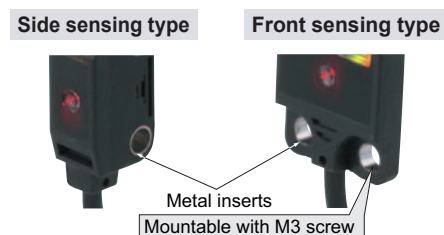
**OPTIONS****Universal sensor mounting bracket is available**

Universal sensor mounting bracket MS-EXL2-4 (for EX-22/23/26/28/29□) and MS-EX20-5 (for EX-23□ only) which can freely adjust the height and the angle of the sensor is available.

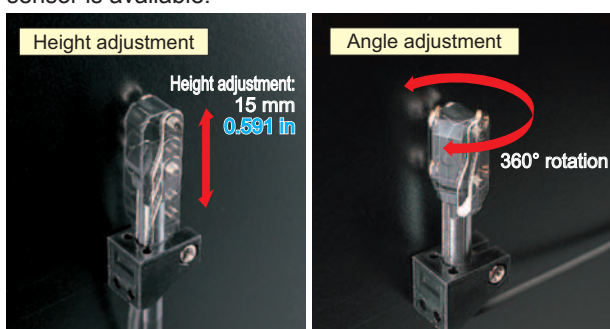
**Mounting spacer for front sensing type is available**

Mounting of the front sensing type is possible from the rear side by using the mounting spacer.

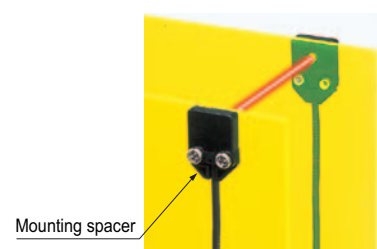
**Slit mask is available**

ø0.5 mm ø0.020 in round slit mask and 0.5 × 3 mm 0.020 × 0.118 in rectangular slit mask are available for both side sensing type and front sensing type sensors.

FIBER SENSORS

LASER SENSORS

PHOTOELECTRIC SENSORS

MICRO PHOTOELECTRIC SENSORS

AREA SENSORS

LIGHT CURTAINS / SAFETY COMPONENTS

PRESSURE / FLOW SENSORS

INDUCTIVE PROXIMITY SENSORS

PARTICULAR USE SENSORS

SENSOR OPTIONS

SIMPLE WIRE-SAVING UNITS

WIRE-SAVING SYSTEMS

MEASUREMENT SENSORS

STATIC ELECTRICITY PREVENTION DEVICES

LASER MARKERS

PLC

HUMAN MACHINE INTERFACES

ENERGY CONSUMPTION VISUALIZATION COMPONENTS

FA COMPONENTS

MACHINE VISION SYSTEMS

UV CURING SYSTEMS

Selection Guide

Amplifier Built-in

Power Supply Built-in

Amplifier-separated

CX-400

CY-100

EX-10

EX-20

EX-30

EX-40

CX-440

EQ-30

EQ-500

MQ-W

RX-LS200

RX

RT-610