

Electrical Specifications

Parameter	Conditions	Value
Average current ¹⁰	Update interval 2 s	19 mA
Max. current	During measurement	75 mA
DC supply voltage (V _{ddmin} - V _{ddmax})	Min. and max. criteria to operate SCD30	3.3 V – 5.5 V
Interface	-	UART (Modbus Point to Point), PWM and I ² C
Input high level voltage (V _{IH})	Min. and max. criteria to operate SCD30	1.75 V – 5.5 V
Input low level voltage (V _{IL})	Min. and max. criteria to operate SCD30	- 0.3 V – 0.9 V
Output low level voltage (V _{OL})	I _{IO} = +8 mA, Max. criteria	0.4 V
Output high level voltage (V _{OH})	I _{IO} = -6 mA, Min. criteria	2.4 V

Table 4 SCD30 electrical specifications

Operation Conditions, Lifetime and Maximum Ratings

Parameter	Conditions	Value
Temperature operating conditions	Valid for CO ₂ sensor.	0 – 50°C
Humidity operating conditions	Non-condensing. Valid for CO ₂ sensor.	0 – 95 %RH
DC supply voltage	Exceeding specified range will result in damage of the sensor.	- 0.3 V – 6.0V
Voltage to pull up selector-pin	Max criteria	4.0 V
Storage temperature conditions	Exceeding specified range will result in damage of the sensor.	- 40°C – 70°C
Maintenance Interval	Maintenance free when ASC field-calibration algorithm ¹¹ is used.	None
Sensor lifetime	-	15 years

Table 5: SCD30 operation conditions, lifetime and maximum ratings

¹⁰ Average current including idle state and processing. Other update rates for small power budgets can be selected via the digital interface.

¹¹ CO₂ concentrations < 400 ppm may result in sensor drifts. For proper function of ASC field-calibration algorithm SCD30 has to be exposed to air with 400 ppm regularly.

2 Package Outline Drawing

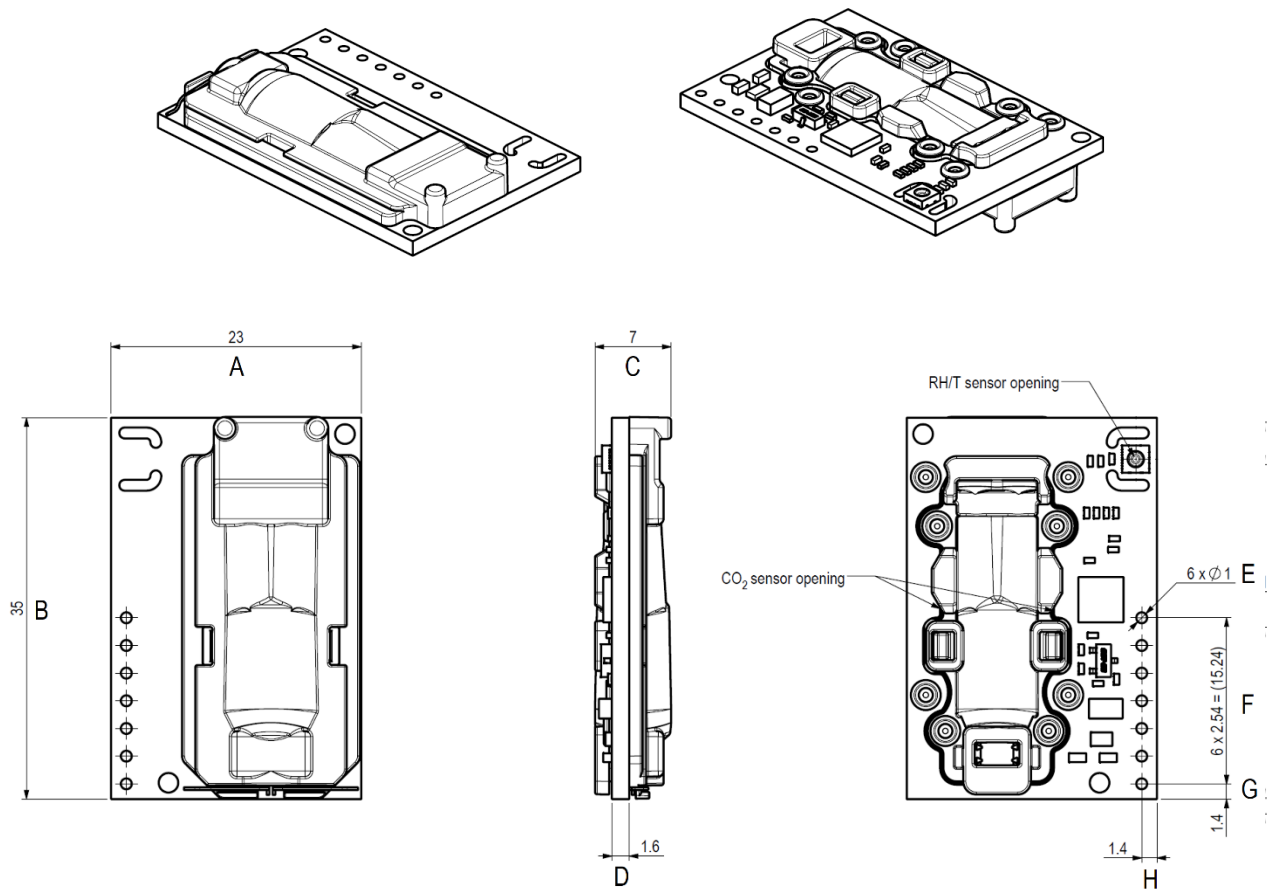

Figure 1 Product outline drawing of SCD30. Pictures on the left show top-view, pictures on the right bottom-view.

Sensor height is 7 mm at the thickest part of SCD30. The weight of one SCD30 sensor is 3.4 g.

Table 6: Nominal dimensions and tolerances SCD30

Dimension	A	B	C	D	E	F	G	H
Nominal [mm]	23.00	35.00	7.00	1.60	1.00	15.24	1.40	1.40
Tolerance [mm]	± 0.20	± 0.20	± 0.70	± 0.20	± 0.15	± 0.30	± 0.15	± 0.15