

High Accuracy Ambient Light Sensor with I²C Interface

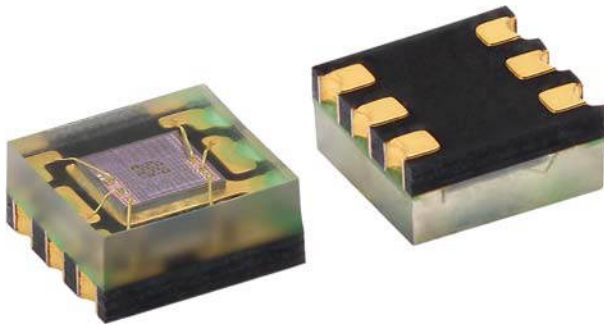

DESCRIPTION

VEML6030 is a high accuracy ambient light digital 16-bit resolution sensor in a miniature transparent 2 mm x 2 mm package. It includes a high sensitive photodiode, a low noise amplifier, a 16-bit A/D converter and supports an easy to use I²C bus communication interface and additional interrupt feature.

The ambient light result is as digital value available.

APPLICATIONS

- Ambient light sensor for mobile devices (e.g. smart phones, touch phones, PDA, GPS) for backlight dimming
- Ambient light sensor for industrial on- / off-lighting operation
- Optical switch for consumer, computing, and industrial devices and displays

FEATURES

- Package type: surface mount
- Dimensions (L x W x H in mm): 2 x 2 x 0.85
- Integrated modules: ambient light sensor (ALS)
- Supply voltage range V_{DD}: 2.5 V to 3.6 V
- Communication via I²C interface
- I²C bus H-level range: 1.7 V to 3.6 V
- Floor life: 72 h, MSL 4, according to J-STD-020
- Low stand by current consumption: typ. 0.5 μA
- Material categorization: for definitions of compliance please see www.vishay.com/doc?99912



AMBIENT LIGHT FUNCTION

- Filtron™ technology adaption: close to real human eye response
- O-Trim™ technology adoption: ALS output tolerance ≤ 10 %
- 16-bit dynamic range for ambient light detection from 0 lx to about 120 klx with resolution down to 0.0036 lx/ct, supports low transmittance (dark) lens design
- 100 Hz and 120 Hz flicker noise rejection
- Excellent temperature compensation
- High dynamic detection resolution
- Software shutdown mode control

PRODUCT SUMMARY

PART NUMBER	OPERATING RANGE (mm)	OPERATING VOLTAGE RANGE (V)	I ² C BUS VOLTAGE RANGE (V)	AMBIENT LIGHT RANGE (lx)	AMBIENT LIGHT RESOLUTION (lx)	OUTPUT CODE	ADC RESOLUTION PROXIMITY / AMBIENT LIGHT
VEML6030	n/a	2.5 to 3.6	1.7 to 3.6	0 to 120 000	0.0036	16 bit, I ² C	- / 0.0036

ORDERING INFORMATION

ORDERING CODE	PACKAGING	VOLUME ⁽¹⁾	REMARKS
VEML6030	Tape and reel	MOQ: 3000	2.0 mm x 2.0 mm x 0.85 mm
VEML6030-GS15		MOQ: 10 000	

Note

⁽¹⁾ MOQ: minimum order quantity

ABSOLUTE MAXIMUM RATINGS ($T_{amb} = 25\text{ }^{\circ}\text{C}$, unless otherwise specified)					
PARAMETER	TEST CONDITION	SYMBOL	MIN.	MAX.	UNIT
Supply voltage		V_{DD}	0	4	V
Operation temperature range		T_{amb}	-25	+85	$^{\circ}\text{C}$
Storage temperature range		T_{stg}	-25	+85	$^{\circ}\text{C}$
Total power dissipation	$T_{amb} \leq 25\text{ }^{\circ}\text{C}$	P_{tot}	-	50	mW
Junction temperature		T_j	-	110	$^{\circ}\text{C}$

BASIC CHARACTERISTICS ($T_{amb} = 25\text{ }^{\circ}\text{C}$, unless otherwise specified)						
PARAMETER	TEST CONDITION	SYMBOL	MIN.	TYP.	MAX.	UNIT
Supply voltage		V_{DD}	2.5	3.3	3.6	V
Shut down current ⁽²⁾	V_{DD} is 3.3 V	I_{sd}	-	0.5	-	μA
Operation mode current ⁽¹⁾	V_{DD} is 3.3 V, PSM = 11, refresh time 4100 ms	I_{DD}	-	2	-	μA
	V_{DD} is 3.3 V, PSM = 00, refresh time 600 ms	I_{DD}	-	8	-	μA
	V_{DD} is 3.3 V, PSM_EN = 0, refresh time 100 ms	I_{DD}	-	45	-	μA
I ² C clock rate range		f_{SCL}	10	-	400	kHz
I ² C bus input H-level range	V_{DD} is 3.3 V	V_{ih}	1.3	-	3.6	V
I ² C bus input L-level range	V_{DD} is 3.3 V	V_{il}	-	-	0.4	V
Digital current out (low, current sink)		I_{ol}	3	-	-	mA
Digital resolution (LSB count)	with ALS_GAIN = "01"		-	0.0036	-	lx/step
Detectable minimum illuminance	with ALS_GAIN = "01"	$E_{V\ min.}$	-	0.0072	-	lx
Detectable maximum illuminance	with ALS_GAIN = "10"	$E_{V\ max.}$	-	120 000	-	lx
Dark offset ⁽¹⁾	with ALS_GAIN = "01"		-	3	-	step

Notes

- (1) Light source: white LED
 (2) Light conditions: dark

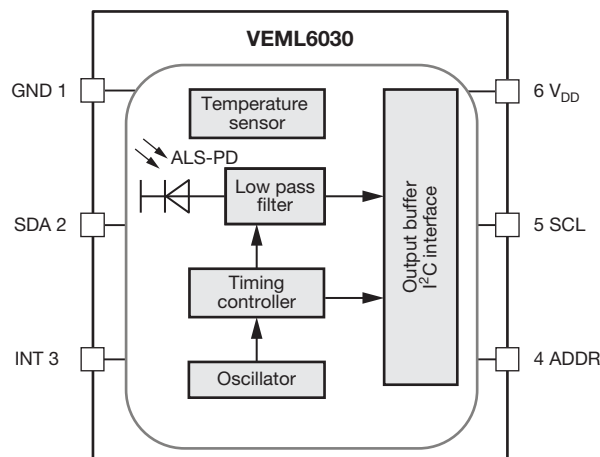
CIRCUIT BLOCK DIAGRAM

Fig. 1 - Block Diagram