

CNC

**AC SERVO/SPINDLE
MDS-A/B Series**

SPECIFICATIONS MANUAL

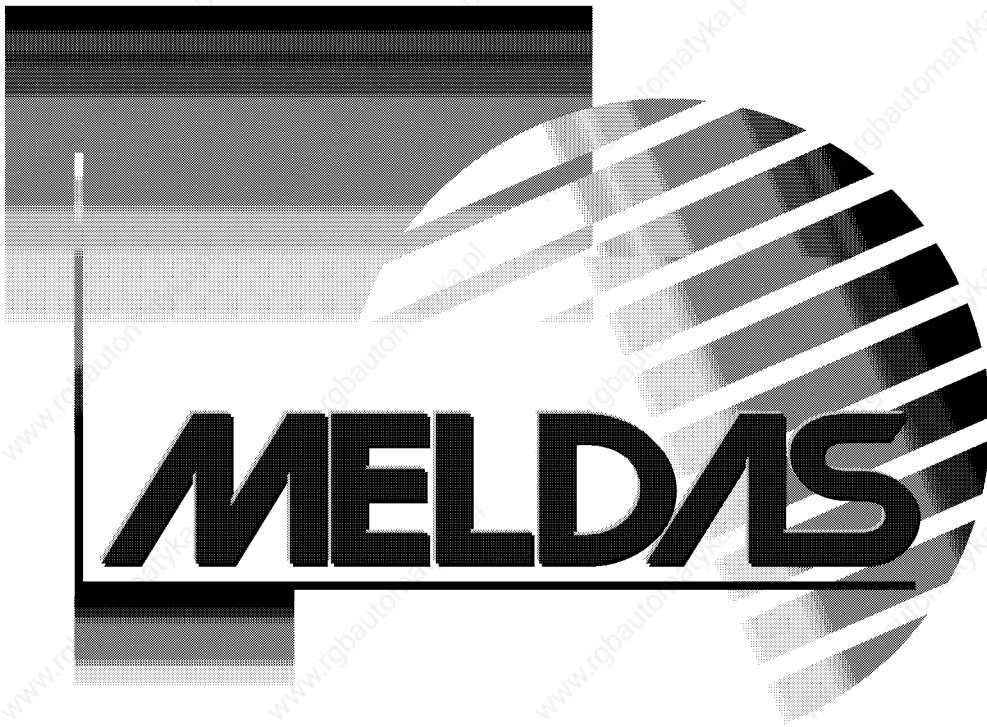

Introduction

Thank you for selecting the Mitsubishi numerical control unit.

This instruction manual describes the handling and caution points for using this AC servo/spindle.

Incorrect handling may lead to unforeseen accidents, so always read this instruction manual thoroughly to ensure correct usage.

Make sure that this instruction manual is delivered to the end user.

Always store this manual in a safe place.

All specifications for the MDS-B Series are described in this manual. However, each CNC may not be provided with all specifications, so refer to the specifications for the CNC on hand before starting use.

Notes on Reading This Manual

- (1) Since the description of this specification manual deals with NC in general, for the specifications of individual machine tools, refer to the manuals issued by the respective machine manufacturers. The "restrictions" and "available functions" described in the manuals issued by the machine manufacturers have precedence to those in the manual.
- (2) The manual describes as many special operations as possible, but it should be kept in mind that items not mentioned in this manual cannot be performed.
- (3) Of the MDS Series, the CV, SP, V1 and V2 units have been sequentially changed from the MDS-A Series to the MDS-B Series during February to May 1996. All of the above models are produced as the MDS-B Series, but to express the difference from the MDS-A Series, the MDS-A Series is also described. If there is no differentiating expression between the A Series and B Series, the item is common for the A Series and B Series. An effort has been made to describe the A Series and B Series type for the common items. However, due to space restrictions, this is abbreviated as A/B-V1. If only the A Series or B Series expression is used, that item is targeted only for the respective series.

Precautions for safety

Please read this manual and auxiliary documents before starting installation, operation, maintenance or inspection to ensure correct usage. Thoroughly understand the device, safety information and precautions before starting operation.

The safety precautions in this instruction manual are ranked as "WARNING" and "CAUTION".



DANGER



WARNING

When a dangerous situation may occur if handling is mistaken leading to fatal or major injuries.

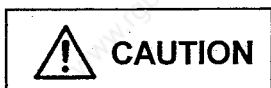

CAUTION

When a dangerous situation may occur if handling is mistaken leading to medium or minor injuries, or physical damage.

Note that some items described as  **CAUTION** may lead to major results depending on the situation. In any case, important information that must be observed is described.

The numeric control unit is configured of the control unit, operation board, servo amplifier, spindle amplifier, power supply + servo drive or spindle drive, servomotor, and spindle motor, etc.

In this manual, the following items are generically called the "servomotor".

- Servomotor
- Spindle motor

In this manual, the following items are generically called the "servo amplifier".

- Servo amplifier
- Spindle amplifier
- Power supply + servo drive or spindle drive

Changes in terminal names

The terminal names have been changed in two stages as shown below.

| | Prior to March 95 | April 95 to March 96 | Following April 96 (MDS-B Series) |
|---------------|-------------------|----------------------|--------------------------------------|
| Terminal name | R | R / L1 | L1 |
| | S | S / L2 | L2 |
| | T | T / L3 | L3 |
| | P | L+ / P | L+ |
| | N | L- / N | L- |
| | Ro | L11 / Ro | L11 |
| | So | L21 / So | L21 |
| | G | G / ⊕ | ⊕ |



DANGER



WARNING

1. Electric shock prevention



Do not open the front cover while the power is ON or during operation. Failure to observe this could lead to electric shocks.



Do not operate the unit with the front cover removed. The high voltage terminals and charged sections will be exposed, and can cause electric shocks.



Do not remove the front cover even when the power is OFF unless carrying out wiring work or periodic inspections. The inside of the servo amplifier is charged, and can cause electric shocks.



Wait at least 10 minutes after turning the power OFF before starting wiring or inspections. Failure to observe this could lead to electric shocks.



Ground the servo amplifier and servomotor with Class 3 grounding or higher.



Wiring and inspection work must be done by a qualified technician.



Wire the servo amplifier and servomotor after installation. Failure to observe this could lead to electric shocks.



Do not touch the switches with wet hands. Failure to observe this could lead to electric shocks.



Do not damage, apply forcible stress, place heavy items or engage the cable. Failure to observe this could lead to electric shocks.



CAUTION

1. Fire prevention



Install the servo amplifier, servomotor and regenerative resistor on noncombustible material. Direct installation on combustible material or near combustible materials could lead to fires.



Shut off the power on the servo amplifier side if a fault occurs in the servo amplifier. Fires could be caused if a large current continues to flow.



Shut off the power with an error signal when using the regenerative resistor. The regenerative resistor could abnormally overheat and cause a fire due to a fault in the regenerative transistor, etc.

CAUTION

2. Injury prevention



Do not apply a voltage other than that specified in Instruction Manual on each terminal. Failure to observe this item could lead to ruptures or damage, etc.



Do not mistake the terminal connections. Failure to observe this item could lead to ruptures or damage, etc.



Do not mistake the polarity (\oplus , \ominus). Failure to observe this item could lead to ruptures or damage, etc.



Do not touch or place parts (cables, etc.) near the servomotor, etc., while the power is turned ON or immediately after turning the power OFF. These parts may reach high temperatures, and can cause burns or part damage.

3. Various precautions

Observe the following precautions. Incorrect handling of the unit could lead to faults, injuries and electric shocks, etc.

(1) Transportation and installation



Correctly transport the product according to its weight.



Use the servomotor's suspension bolts only when transporting the servomotor. Do not transport the servomotor when it is installed on the machine.



Do not stack the products above the tolerable number.



Do not hold the cables, axis or detector when transporting the servomotor.



Do not hold the connected wires or cables when transporting the servomotor.



Do not hold the front cover when transporting the servo amplifier. The unit could drop.



Follow this Instruction Manual and install the unit in a place where the weight can be borne.



Do not get on top of or place heavy objects on the unit.



Always observe the installation directions.



Secure the specified distance between the servo amplifier and control panel, or between the servo amplifier and other devices.



Do not install or run a servo amplifier or servomotor that is damaged or missing parts.



Do not block the intake or exhaust ports of the servomotor provided with a cooling fan.



Do not let foreign objects enter the servo amplifier or servomotor. In particular, if conductive objects such as screws or metal chips, etc., or combustible materials such as oil enter, rupture or breakage could occur.



The servo amplifier and servomotor are precision devices, so do not drop them or apply strong impacts to them.



CAUTION



Store and use the units under the following environment conditions.

| Environment | Conditions | |
|---------------------|--|--|
| | Servo amplifier | Servomotor |
| Ambient temperature | 0°C to +55°C (with no freezing) | 0°C to +40°C (with no freezing) |
| Ambient humidity | To follow separate specifications | 80%RH or less (with no dew condensation) |
| Storage temperature | To follow separate specifications | -15°C to +70°C |
| Storage humidity | To follow separate specifications | 90% RH or less (with no dew condensation) |
| Atmosphere | Indoors (Where unit is not subject to direct sunlight) With no corrosive gas, combustible gas, oil mist or dust | |
| Altitude | 1000m or less above sea level | |
| Vibration | To follow separate specifications | |



Securely fix the servomotor to the machine. Insufficient fixing could lead to the servomotor slipping off during operation.



Always install the servomotor with reduction gears in the designated direction. Failure to do so could lead to oil leaks.



Never touch the rotary sections of the servomotor during operations. Install a cover, etc., on the shaft.



When coupling to a servomotor shaft end, do not apply an impact by hammering, etc. The detector could be damaged.



Do not apply a load exceeding the tolerable load onto the servomotor shaft. The shaft could break.



When storing for a long time, please contact the Service Center or Service Station.



CAUTION

(2) Wiring



Correctly and securely perform the wiring. Failure to do so could lead to runaway of the servomotor.



Do not install a condensing capacitor, surge absorber or radio noise filter on the output side of the servo amplifier.



Correctly connect the output side (terminals U, V, W). Failure to do so could lead to abnormal operation of the servomotor.



Do not directly connect a commercial power supply to the servomotor. Doing so could lead to faults.



When using an inductive load such as a relay, always connect a diode as a noise measure parallel to that load.



When using a capacitance load such as a lamp, always connect a protective resistor as a noise measure serial to that load.



When connecting a DC relay for the control output signals, do not mistake the polarity of the diode. Failure to observe this could cause the signals not to be output due to a fault or the protective circuit to fail.

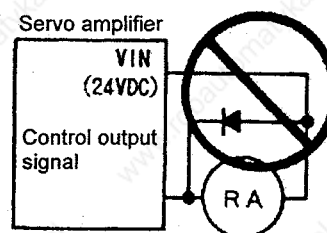

Do not connect/disconnect the cables connected between the units while the power is ON.



Securely tighten the cable connector fixing screw or fixing mechanism. An insecure fixing could cause the cable to fall off while the power is ON.



When use of a shielded cable is instructed in the connection diagrams, always ground the cable with a cable clamp, etc.



Always separate the signals wires from the drive wire and power line.



Use wires and cables that have a wire diameter, heat resistance and flexibility that conforms to the system.

(3) Trial operation and adjustment



Check and adjust each program and parameter before starting operation. Failure to do so could lead to unforeseen operation of the machine.



Do not make remarkable adjustments and changes as the operation could become unstable.

⚠ CAUTION

(4) Usage methods

- ⚠ Install an external emergency stop circuit so that the operation can be stopped and power shut off immediately.
- ⚠ Turn the power OFF immediately if smoke, abnormal noise or odors are generated from the spindle motor or spindle amplifier.
- ⚠ Unqualified persons must not disassemble or repair the unit.
- ⚠ Never make modifications.
- ⚠ Reduce magnetic damage by installing a noise filter. The electronic devices used near the servo amplifier could be affected by magnetic noise.
- ⚠ Use the spindle motor, spindle amplifier and regenerative resistor with the designated combination. Failure to do so could lead to fires or trouble.
- ⚠ The brakes (magnetic brakes) assembled into the servomotor are for holding, and must not be used for normal braking.
- ⚠ There may be cases when holding is not possible due to the magnetic brake's life or the machine construction (when ball screw and servomotor are coupled via a timing belt, etc.). Install a stop device to ensure safety on the machine side.
- ⚠ After changing the parameters or after maintenance and inspection, always test the operation before starting actual operation.
- ⚠ Do not enter the movable range of the machine during automatic operation. Never place body parts near or touch the spindle during rotation.
- ⚠ Follow the power supply specification conditions given in the separate specifications manual for the power (input voltage, input frequency, tolerable power failure time, etc.).

(5) Troubleshooting

- ⚠ If a hazardous situation is predicted during power failure or product trouble, use a servomotor with magnetic brakes or install an external brake mechanism.

- ⚠ Use a double circuit configuration that allows the operation circuit for the magnetic brakes to be operated even by the external emergency stop signal.

Shut off with NC brake control PLC output.

With a servo amplifier not provided with the EM1/EM2 output, provide double protection with the emergency stop signal (EMG).

Shut off with the servo amplifier output (EMG1/EMG2).

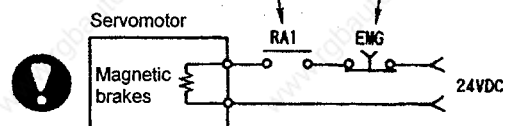

- ⚠ Always turn the input power OFF when an alarm occurs.
- ⚠ Never go near the machine after restoring the power after a failure, as the machine could start suddenly. (Design the machine so that personal safety can be ensured even if the machine starts suddenly.)



CAUTION

(6) Maintenance, inspection and part replacement



Always backup the servo amplifier programs and parameters before starting maintenance or inspections.



The capacity of the electrolytic capacitor will drop due to deterioration. To prevent secondary damage due to failures, replacing this part every five years when used under a normal environment is recommended. Contact the Service Center or Service Station for replacement.



Do not perform a megger test (insulation resistance measurement) during inspections.



If the battery low warning is issued, save the machining programs, tool data and parameters with an input/output unit, and then replace the battery.



Do not short circuit, charge, overheat, incinerate or disassemble the battery.

(7) Disposal



Treat this unit as general industrial waste.

If the heat radiating fins are protruding from the rear of the MDS Series, substitute Freon is used. Do not dispose of this type of unit as general industrial waste. Always contact the Service Station or Service Center for disposal.



Do not disassemble the spindle motor or spindle amplifier.



Dispose of the battery according to local laws.

(8) General precautions

The drawings given in this Specifications and Maintenance Instruction Manual show the covers and safety partitions, etc., removed to provide a clearer explanation. Always return the covers or partitions to their respective places before starting operation, and always follow the instructions given in this manual.

CONTENTS

Chapter I MDS-A/B Series Servo/Spindle System Configuration

| | |
|---|------|
| 1. Outline | I-1 |
| 2. Drive Section System Configuration | I-4 |
| (1) Basic system configuration | I-5 |
| (2) List of units | I-6 |
| (3) List of unit dimensions | I-7 |
| 3. Unit Installation | I-8 |
| 4. Connection of Each Unit | I-10 |
| 4.1 Layout of each unit | I-11 |
| 4.2 Link bar specifications | I-11 |
| 4.3 Unit separated layout | I-13 |
| 4.4 Precautions for installing multiple power supply units | I-14 |
| 4.5 Precautions for installing only one power supply unit for the 2CH communication specifications with the NC | I-16 |
| 4.6 Connection of battery unit | I-17 |
| 5. Drive Section Connector and Cable Specifications | I-18 |
| 5.1 Half pitch cable connection system | I-18 |
| 5.2 Cable details | I-20 |
| 5.2.1 Communication cable SH21 (semi ordered product) | I-20 |
| 5.2.2 Terminator A-TM (ordered part) | I-20 |
| 5.2.3 Servo drive unit detector cable | I-21 |
| (1) HA053/13 motor built-in detector cable | I-21 |
| (2) Cables for OHE25K-□, OHA25K-□, OSE104□, OSA104□, OSE105□ and OSA105□ detectors | I-22 |
| 5.2.4 Brake cable | I-23 |
| 5.2.5 Communication cable SH21 connector | I-24 |
| (a) 10320-3210-000 | I-24 |
| (b) 10320-52F0-008 | I-24 |
| 5.2.6 Cannon plug for servomotor detector | I-25 |
| 1. Standard plug | I-25 |
| 2. JIS corresponding plugs (Hirose) | I-27 |
| 5.2.7 Cable materials | I-29 |
| 5.2.8 Cable protection tube (Measures against noise) | I-30 |
| 5.2.9 Oil proof type AC servomotor cable connectors (Recommendation 1) | I-31 |
| 5.2.10 Oil proof type servomotor cable connectors (Recommendation 2) | I-32 |
| 5.2.11 Cable clamp | I-33 |
| 5.2.12 Spindle control circuit cable list | I-34 |
| (1) CNP5 cable | I-37 |
| (2) CNP6M cable | I-38 |
| (3) CNP6A cable | I-39 |
| (4) CNP7A cable | I-40 |
| (5) CNP7B cable | I-41 |
| (6) CNP7H cable | I-42 |
| (7) CNP67A cable | I-43 |
| (8) CNP71A cable | I-44 |
| (9) CNP71B cable | I-45 |
| (10) CNP71H cable | I-46 |
| (11) CNP5H cable | I-47 |
| (12) CNP8 cable | I-48 |
| 5.2.13 Cable assembly procedure | I-49 |

| | |
|--|------|
| 6. Outline Drawing | I-53 |
| 6.1 Outline list | I-53 |
| 6.2 Power supply unit | I-54 |
| 6.3 1-axis servo drive unit | I-55 |
| 6.4 2-axis servo drive unit | I-56 |
| 6.5 Spindle drive unit | I-56 |
| 6.6 Battery unit | I-57 |
| 6.7 AC reactor | I-58 |
| 6.8 Dynamic brake unit..... | I-59 |
| 6.9 Contactor | I-59 |
| 6.10 NFB | I-59 |
| 7. Heating Value | I-60 |
| 8. Selection of Capacity | I-61 |
| 8.1 Selection of power supply unit | I-61 |
| 8.2 Selection of power supply capacity | I-63 |
| 8.3 Selection of wire size | I-64 |
| 8.4 Selection of AC reactor, contactor and NFB | I-69 |

Chapter II MDS-A-CV, MDS-B-CV Power Regeneration Type/Power Supply Section
MDS-A-CR Resistance Regeneration Type/Power Supply Section A

| | |
|---|-------|
| 1. Power Regeneration Type Power Supply | |
| 1.1 Outline | II-1 |
| 1.2 Model configuration | II-1 |
| 1.3 List of specifications | II-2 |
| 1.4 Hardware setting | II-3 |
| 1.5 Status display | II-4 |
| 1.5.1 7-segment LED display | II-4 |
| 1.5.2 Charge lamp | II-4 |
| 1.6 List of alarms and warnings | II-5 |
| (1) Alarms | II-5 |
| (2) Warning | II-6 |
| 1.7 Explanation of connectors and terminal block | II-7 |
| 1.8 Functions added with MDS-B Series (Power supply external emergency stop function)..... | II-8 |
| 1.9 Main circuit connection | II-10 |
| 2. Resistance Regeneration Type Power Supply | II-12 |
| 2.1 Outline | II-12 |
| 2.2 Mode configuration | II-12 |
| 2.3 List of specifications | II-13 |
| 2.4 Capacity selection | II-13 |
| 2.4.1 Regenerative resistor unit capacity selection | II-13 |
| 2.5 Hardware and parameter settings | II-15 |
| 2.6 Status display | II-17 |
| 2.7 List of alarms and warnings | II-18 |
| 2.8 Resistance regeneration converter unit outline drawing..... | II-19 |
| 2.9 Connection of each unit..... | II-20 |
| 2.10 Resistance regeneration converter wiring diagram | II-21 |
| 2.11 Regenerative resistor unit outline drawing | II-24 |

Chapter III MDS-A-Vx, MDS-B-Vx Servo System Section

| | |
|--|--------|
| 1. Outline | III-1 |
| 2. Motor | III-2 |
| 2.1 Outline | III-2 |
| 2.2 Model configuration | III-3 |
| 2.3 Main equipment list | III-4 |
| 2.4 Specifications list | III-5 |
| 2.5 Outline dimension drawing | III-7 |
| 2.6 Data sheet | III-20 |
| (1) Characteristics list | III-20 |
| (2) Torque-speed characteristic | III-24 |
| (3) Duty drive characteristic | III-29 |
| 2.7 Motor connection | III-30 |
| (1) Cannon plugs to be used | III-30 |
| (2) Terminal box type motors | III-32 |
| (3) Cables to be used | III-34 |
| 2.8 Motors with electromagnetic brake | III-35 |
| (1) Outline of motors with electromagnetic brake | III-35 |
| (2) Characteristics of electromagnetic brakes | III-36 |
| (3) Using electromagnetic brake | III-37 |
| (a) Brake excitation power | III-37 |
| (b) Safety considerations | III-38 |
| (c) Precautions for sequence | III-39 |
| 2.9 Motor vibration resistance | III-40 |
| 2.10 Motor shaft strength | III-41 |
| 3. Detectors | III-43 |
| 3.1 List of model names | III-43 |
| 3.2 Specification | III-44 |
| 3.3 Machine end detector outline drawing | III-45 |
| 3.4 Serial pulse encoder | III-47 |
| 3.4.1 Features | III-47 |
| 3.4.2 Types | III-47 |
| 3.4.3 Outline drawing | III-48 |
| 3.4.4 Cable connection diagram | III-49 |
| 3.4.5 Compatibility | III-51 |
| 3.4.6 Maintenance | III-53 |
| 4. Servomotor and Detector Installation | III-54 |
| 4.1 Installation | III-54 |
| 4.2 Coupling with the load | III-58 |
| (1) Direct coupling | III-58 |
| (2) Gear coupling | III-59 |
| (3) Span ring | III-59 |
| (4) Taper gauge | III-60 |
| (5) Other reference items | III-60 |
| 5. MDS-A/B-V1 Servo Drive | III-61 |
| 5.1 Model configuration | III-61 |
| 5.2 Servo drive specifications | III-62 |
| 5.3 Connection of dynamic brake unit | III-62 |
| 5.4 Hardware setting | III-64 |
| 5.5 Parameter settings | III-65 |
| (1) Parameter screens | III-65 |
| (2) Explanation of parameters | III-66 |

| | |
|--|---------|
| (3) Parameter details | III-72 |
| (4) Supplement explanation | III-77 |
| (a) Lost motion and overshooting compensation + and – directions | III-77 |
| (b) Limits regarding PC1 and PC2 | III-77 |
| (c) Current limits | III-78 |
| (5) Standard parameters per motor | III-79 |
| 1. 2000rpm motor | III-79 |
| 2. 3000rpm motor | III-80 |
| 3. Low inertia motor | III-81 |
| (6) Parameters per servo system | III-82 |
| 5.6 Alarm and warnings | III-83 |
| 5.7 Explanation of connector and terminal block | III-87 |
| 5.8 Main circuit and brake connection | III-88 |
| 5.8.1 Main circuit | III-88 |
| 5.8.2 Brake | III-90 |
| 5.9 Wiring system diagrams for systems | III-91 |
| (1) Servo system configuration table | III-92 |
| (2) Cable system drawings for each specification | III-93 |
| 5.10 D/A output function | III-95 |
| 5.10.1 Outline | III-95 |
| 5.10.2 Hardware specifications | III-95 |
| 5.10.3 Parameters | III-96 |
| 5.10.4 Output data No. | III-96 |
| 5.10.5 Setting of output magnification | III-97 |
| 5.10.6 Others | III-97 |
| 6. MDS-A/B-V2 Servo Drive | III-98 |
| 6.1 Model configuration | III-98 |
| 6.2 Servo drive unit specifications | III-99 |
| 6.3 Hardware setting | III-102 |
| 6.4 Status display | III-103 |
| 6.5 Explanation of terminal block and connectors | III-105 |
| 6.6 Main circuit connection | III-106 |
| 7. Selection of Capacity | III-108 |
| 7.1 Selection of servo system | III-108 |
| 7.1.1 Types of drive systems | III-108 |
| 7.1.2 Selection of servomotor | III-109 |
| 7.2 Determining the coasting amount with emergency stop | III-120 |

Chapter IV MDS-A-SP, MDS-B-SP Spindle System Section
MDS-A-CSP Large Capacity Spindle Drive Section

| | |
|---|------|
| 1. Outline | IV-1 |
| 1.1 Features of the MDS-A-SP and MDS-B-SP spindle system | IV-1 |
| 1.2 Precautions for use | IV-1 |
| 1.3 Model configuration | IV-2 |
| 1.4 Configuration | IV-3 |
| 1.4.1 Basic configuration (no added functions) | IV-3 |
| 1.4.2 With orientation function | IV-3 |
| 1.4.3 High-speed synchronous tap/spindle synchronization/with orientation function | IV-5 |
| 1.4.4 OSE90K + 1024 encoder C-axis control/with orientation function | IV-6 |
| 1.4.5 OSE90K + 1024 encoder C-axis control and high-speed synchronous tap/ spindle synchronization/with orientation function | IV-7 |

| | | |
|--------------------|--|----------------|
| 1.4.6 | MBE90K encoder C-axis control/with orientation function | IV-8 |
| 1.4.7 | MBE90K encoder C-axis control and high-speed synchronous tap/ spindle synchronization/with orientation function | IV-8 |
| 1.4.8 | MHE90K encoder C-axis control/with orientation function | IV-9 |
| 1.4.9 | MHE90K encoder C-axis control and high-speed synchronous tap/ spindle synchronization/with orientation function | IV-9 |
| 1.5 | Device-to-device connections | IV-10 |
| 2. | Specifications..... | IV-11 |
| 2.1 | AC spindle motor and controller specifications | IV-11 |
| 2.2 | Output characteristics | IV-15 |
| 2.3 | Outline Dimension drawings | IV-17 |
| 2.3.1 | Motor | IV-17 |
| 3. | Functions | IV-24 |
| 3.1 | Control input signals | IV-24 |
| 3.2 | Control output signals | IV-27 |
| 3.3 | Meter outputs | IV-30 |
| 3.4 | Output interface | IV-32 |
| 4. | Status Display and Parameter Settings..... | IV-33 |
| 4.1 | Status display with 7-segment LED | IV-33 |
| 4.2 | Spindle parameters | IV-34 |
| 4.3 | Spindle specification parameters screen | IV-52 |
| 4.4 | Spindle monitor screen | IV-53 |
| 4.5 | Alarm and warning table | IV-57 |
| 5. | Optional Specifications and Parts | IV-58 |
| 5.1 | Orientation specifications (optional) | IV-58 |
| 5.1.1 | 1-point orientation using magnesensor | IV-58 |
| 5.1.2 | 4096-point orientation using encoder | IV-66 |
| 5.1.3 | 4096-point orientation using motor built-in encoder | IV-69 |
| 5.1.4 | Operation of orientation | IV-69 |
| 5.2 | Synchronous tap function (option) | IV-72 |
| 5.2.1 | Closed type synchronous tap | IV-72 |
| 5.2.2 | Semi-closed type synchronous tap | IV-72 |
| 5.2.3 | Operation of synchronous tap..... | IV-72 |
| 5.3 | C-axis control (optional) | IV-73 |
| 5.3.1 | When using encoder (OSE90K + 1024 BKO-NC6336H01) | IV-73 |
| 5.3.2 | When using built-in encoder (MBE90K) | IV-76 |
| 5.3.3 | When using built-in encoder (MHE90K) | IV-76 |
| 5.4 | Single parts (optionally supplied parts) | IV-77 |
| 5.4.1 | Power step-down transformer | IV-77 |
| 5.4.2 | Noise filter | IV-79 |
| 5.5 | Other optional specifications | IV-81 |
| 5.6 | Theoretical acceleration and deceleration times | IV-82 |
| 6. | Large Capacity Spindle Drive | IV-83 |
| 6.1 | Outline dimensions..... | IV-83 |
| 6.2 | Connection of each unit..... | IV-85 |
| 6.3 | Drive section connector and cable specifications..... | IV-86 |
| 6.4 | Electrical specifications | IV-87 |
| Appendix 1. | EN Standards Step-down Insulation Transformer | A I-1 |
| Appendix 2. | EMC Installation Guidelines | A II-1 |
| Appendix 3. | Unit Systems | A III-1 |
| Supplement | | S-1 |

I. MDS-A/B Series Servo/Spindle System Configuration

1. Outline

MDS-B Series servo and spindle system outline

The MDS-A Series is a drive system that corresponds to the MELDAS M500 Series NC that has been developed to totally connected the servo drive and spindle drive sections. The MDS-B Series is the successor to the MDS-A Series, and has been developed to satisfy European Safety Standards. This Series has the following features.

(1) Compact and lightweight

The converters that were conventionally built in each servo and spindle drive have been integrated into one unit. The drive system volume, installation area and weight have been drastically reduced with the incorporation of high density mounted electronic parts IGBT-IPM (Intelligent Power Module) and the high performance heat radiating fin.

(2) Standardization of dimensions

The outline has been standardized to the book end type, and by unifying the height and depth dimensions, installation in cabinets has been made easy. Furthermore, by matching the shape with the NC unit, an integrated appearance with the NC has been realized.

(3) Low heat generation

By incorporating the IPM and using power supply regeneration in the servo drive, the amount of heat generated has been greatly reduced.

(4) High speed and precision processing

A high speed CPU has been mounted on the control PCB, and a 100,000 pulse/rotation sub micron detector has been incorporated as a standard to allow faster and more precise interpolation.

By incorporating the stable position loop control (SHG control) method, having an outstanding response, the positioning time and tracking have been improved and the machine vibration during acceleration/deceleration has been reduced.

The cutting performance and cutting precision during position control have been improved by using the high speed CPU also for the spindle drive.

(5) High speed spindle orientation

Smooth operations and minimum orientation times have been realized by using the high speed orientation method while allows direct orientation from the high speed during the spindle drive.

(6) Features of the MDS-B Series

(a) European Safety Standards compliant

This Series complies with the European Safety Standards (LVD). Refer to the section "Compliance to European EC Directives" for details.

(7) Addition of power supply emergency stop input line

With the B Series, the external contactor can be directly shut off from the power supply even when the emergency stop hot line from the NC does not function for any reason.

(This function is validated with the rotary switch and connected drive parameter settings. Thus, the functions do not change from the conventional functions when used in the same manner as the A Series.)

Compliance to European EC Directives

1. European EC Directives

The European EC Directives were issued to unify Standards within the EU Community and to smooth the distribution of products of which the safety is guaranteed. In the EU Community, the attachment of a CE mark (CE marking) to the product being sold is mandatory to indicate that the basic safety conditions of the Machine Directives (issued Jan. 1995), EMC Directives (issued Jan. 1996) and the Low-voltage Directives (issued Jan. 1997) are satisfied. The machines and devices in which the servo and spindle drive are assembled are a target for CE marking.

The servo and spindle drive are components designed not to function as a single unit but to be used with a combination of machines and devices. Thus, these are not subject to the EMC Directives, and instead the machines and devices in which the servo is assembled are targeted.

The MDS-B Series complies with the Standards related to the Low-voltage Directives in order to make CE marking of the assembled machines and devices easier. The EMC INSTALLATION GUIDELINES (BNP-B8582-45) which explain the servo amplifier installation method and control panel manufacturing method, etc., has been prepared to make compliance to the EMC Directives easier. Contact Mitsubishi or your dealer for more information. (Refer to Appendix 2.)

2. Cautions for EC Directive compliance

Use the Low Voltage Directive compliance part for the servo/spindle drive and servo/spindle motor. In addition to the items described in this instruction manual, observe the items described below.

(1) Configuration

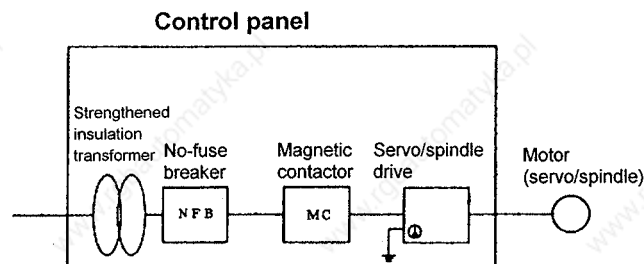

(2) Environment

The servo/spindle drive must be used within an environment having a Pollution Class of 2 or more as stipulated in the IEC664. For this, install the servo amplifier in a control panel having a structure (IP54) into which water, oil, carbon and dust cannot enter.

(3) Power supply

- ① The servo/spindle drive must be used with the overvoltage category II conditions stipulated in IEC664. For this, prepare a reinforced insulated transformer that is IEC or EN Standards complying at the power input section.

(4) Earthing

- ① To prevent electric shocks, always connect the servo amplifier protective earth (PE) terminal (terminal with ⊕ mark) to the protective earth (PE) on the control panel. (Always carry this out even when using a leakage breaker.)
- ② When connecting the earthing wire to the protective earth (PE) terminal, do not tighten the wire terminals together. Always connect one wire to one terminal.



1. Outline

(5) Wiring

- ① Always use solderless terminals with insulation tubes so that the wires connected to the servo amplifier terminal block do not contact the neighboring terminals.

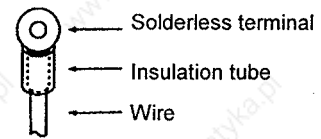

(6) Peripheral devices and options

- ① Use a no-fuse breaker and magnetic contactor that comply with the EN/IEC Standards.
- ② Select the wire size according to EN60204.

(7) Others

Refer to the EMC INSTALLATION GUIDELINES for other EMC Directive measures.

2. Drive Section System Configuration

WARNING

1. Wiring and inspection work must be done by a qualified technician.
2. Wait at least 10 minutes after turning the power OFF before starting wiring or inspections. Failure to observe this could lead to electric shocks.
3. Wire the servo amplifier and servomotor after installation. Failure to observe this could lead to electric shocks.
4. Do not damage, apply forcible stress, place heavy items or engage the cable. Failure to observe this could lead to electric shocks.

CAUTION

1. Correctly carry out the wiring. Failure to do so could lead to runaway of the servomotor, or to injuries.
2. Do not mistake the terminal connections. Failure to observe this item could lead to ruptures or damage, etc.
3. Do not mistake the polarity (\oplus , \ominus). Failure to observe this item could lead to ruptures or damage, etc.
4. When connecting a DC relay for the control output signals, do not mistake the polarity of the diode. Failure to observe this could cause the signals not to be output due to a fault or the protective circuit to fail.
5. Magnetic noise may affect the electronic devices used near the control unit or servo amplifier. Keep the effect of magnetic obstacles to a minimum by installing a noise filter, etc. (Refer to Option Specifications Parts 5.4.2.)
6. Do not install a phase advancing capacitor, surge absorber or radio noise filter (option LF-) on the power wire of the servomotor.
7. Shut off the power with the fault signal. Failure to do so could lead the regenerative resistor to abnormally overheat and to fires if the transistor fails, etc.
8. Do not make any modifications to the unit.
9. Some parts are the MDS-B Series instead of the MDS-A Series. The basic specifications do not differ, but if newly added functions or a newly added capacity is being used, always confirm the changed points before starting use.

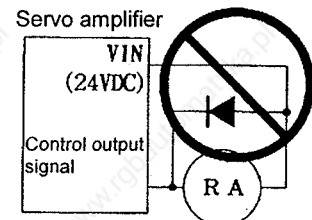

CAUTION

Cautions for using MDS-B Series

- 1) The power supply unit MDS-B-CV-370 has a different rush sequence from the other supplies. Thus, always install an external contactor. Do not share the contactor with other power supplies.
- 2) The servo drive unit MDS-B-V1-110/150 does not have built-in dynamic brakes. Thus, always use an external dynamic brake unit.

2. Drive Section System Configuration

(1) Basic system configuration (Example: Spindle + 3-axis servo)

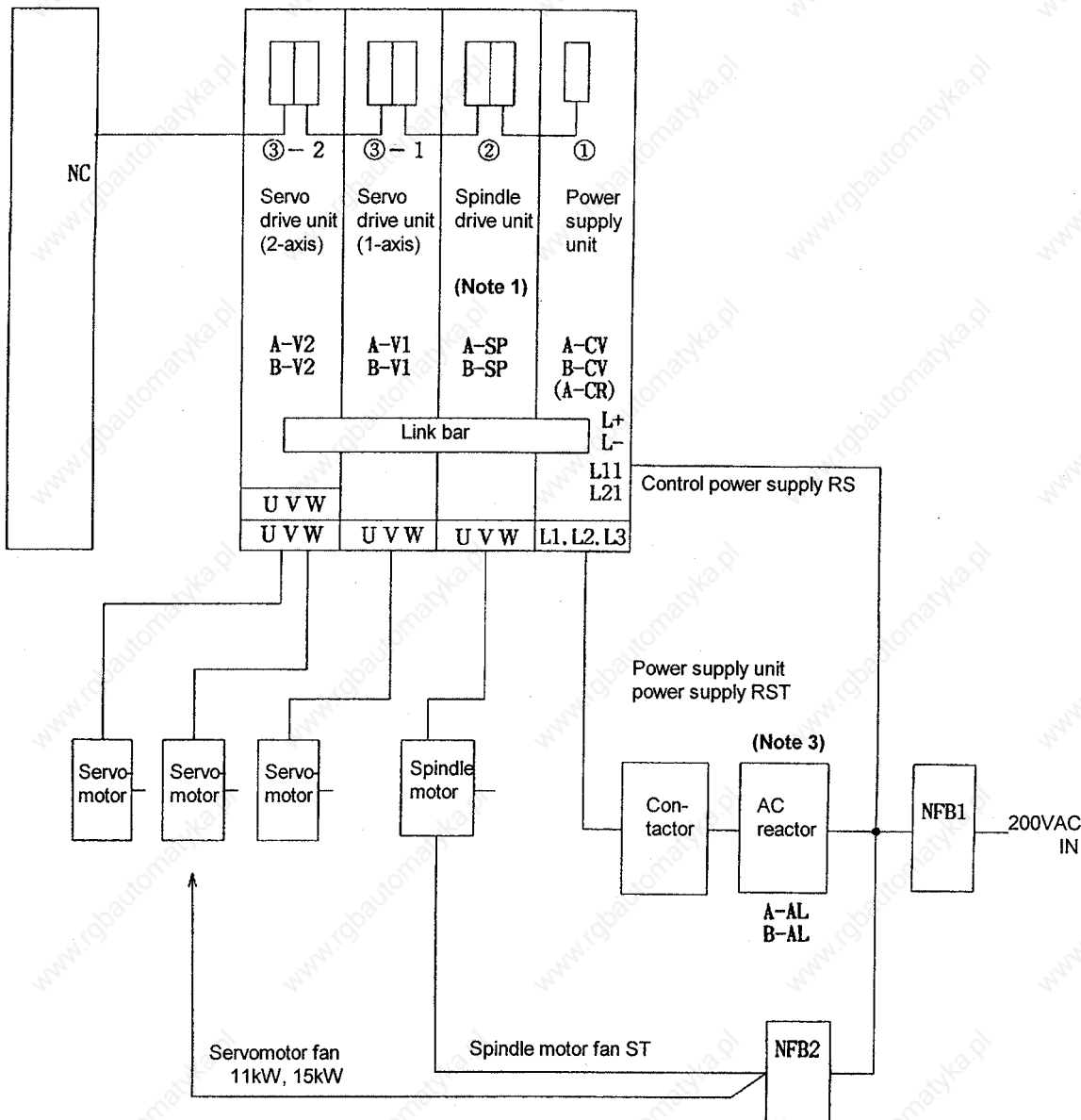

(Note 1) In systems which use a spindle drive unit, the spindle drive unit must be placed next to the power supply unit as shown above. Also install the 11kW and higher servo drive unit next to the power supply unit.

If also using spindle drive units, arrange the units next to the power supply in order of drive capacity size.

(Note 2) Excluding the MDS-B-CV-370, the use of a contactor can be selected.

Excluding the MDS-B-CV-370, use is possible without a contactor, but use of a contactor is recommended for safety purposes.

The rotary switch on the power supply unit must be set as follows according to whether the contactor is installed.

{ Contactor installed Rotary switch setting = 0
 { Contactor not installed Rotary switch setting = 1

With the A-CR, the rotary switch is fixed to 0. Always install a contactor. Also install a contactor for the MDS-B-CV-370.

(Note 3) Always install the AC reactor. (The AC reactor is shipped from Mitsubishi.)

Note that this is not required for the A-CR. Wire the AC reactor to the front (NF) side of the contactor.

2. Drive Section System Configuration

| ③ Servo drive unit ... Servomotor control | | | | | | | | | | | | | | | | | | | | | | | | |
|---|-----|-------------|---------------|------------|-------|------|--------------------|----|----|----|----|----|----|----|-----|-----|-----|-----|-----|-----|-----|-----|-----|--|
| No. of axes | No. | Model | Capacity (kW) | Dimensions | | Axis | Drive motor (HA**) | | | | | | | | | | | | | | | | | |
| | | | | MDS-A | MDS-B | | 053 | 13 | 23 | 33 | 40 | 43 | 80 | 83 | 100 | 103 | 200 | 203 | 300 | 700 | 900 | 11K | 15K | |
| 1-axis type | 1 | A/B-V1-01 | 0.1 | A0 | A0 | | | | | | | | | | | | | | | | | | | |
| | 2 | A/B-V1-03 | 0.3 | | | | | | | | | | | | | | | | | | | | | |
| | 3 | A/B-V1-05 | 0.5 | | | | | | | | | | | | | | | | | | | | | |
| | 4 | A/B-V1-10 | 1.0 | A1 | A1 | | | | | | | | | | | | | | | | | | | |
| | 5 | A/B-V1-20 | 2.0 | | | | | | | | | | | | | | | | | | | | | |
| | 6 | A/B-V1-35 | 3.5 | | | | | | | | | | | | | | | | | | | | | |
| | 7 | A/B-V1-45 | 4.5 | B1 | B1 | | | | | | | | | | | | | | | | | | | |
| | 8 | A/B-V1-70 | 7.0 | C1 | C1 | | | | | | | | | | | | | | | | | | | |
| | 9 | A/B-V1-90 | 9.0 | | | | | | | | | | | | | | | | | | | | | |
| | 10 | B-V1-110 | 11.0 | | | | | | | | | | | | | | | | | | | | | |
| | 11 | B-V1-150 | 15.0 | | D1 | | | | | | | | | | | | | | | | | | | |
| 2-axis type | 1 | A/B-V2-0101 | 0.1×2 | A0 | A0 | L/M | | | | | | | | | | | | | | | | | | |
| | 2 | A/B-V2-0301 | 0.3+0.1 | | | L | | | | | | | | | | | | | | | | | | |
| | 3 | A/B-V2-0303 | 0.3×2 | | | M | | | | | | | | | | | | | | | | | | |
| | 4 | A/B-V2-0501 | 0.5+0.1 | | | L/M | | | | | | | | | | | | | | | | | | |
| | 5 | A/B-V2-0503 | 0.5+0.3 | | | L | | | | | | | | | | | | | | | | | | |
| | 6 | A/B-V2-0505 | 0.5+0.1 | | | M | | | | | | | | | | | | | | | | | | |
| | 7 | A/B-V2-1005 | 1.0+0.5 | A1 | A1 | L | | | | | | | | | | | | | | | | | | |
| | 8 | A/B-V2-1010 | 1.0×2 | | | M | | | | | | | | | | | | | | | | | | |
| | 9 | A/B-V2-2010 | 2.0+1.0 | | | L/M | | | | | | | | | | | | | | | | | | |
| | 10 | A/B-V2-2020 | 2.0×2 | B1 | B1 | L | | | | | | | | | | | | | | | | | | |
| | 11 | A/B-V2-3510 | 3.5+1.0 | | | M | | | | | | | | | | | | | | | | | | |
| | 12 | A/B-V2-3520 | 3.5+2.0 | | | L | | | | | | | | | | | | | | | | | | |
| | 13 | A/B-V2-3535 | 3.5×2 | | | M | | | | | | | | | | | | | | | | | | |
| | 14 | B-V2-4520 | 4.5+2.0 | | | L/M | | | | | | | | | | | | | | | | | | |
| | 15 | B-V2-4535 | 4.5+3.5 | | | L | | | | | | | | | | | | | | | | | | |

* Refer to Chapter III "Servo System Section 5.2 Servo drive specifications" for the combination of the low inertia motor and amplifier.

(3) List of unit dimensions

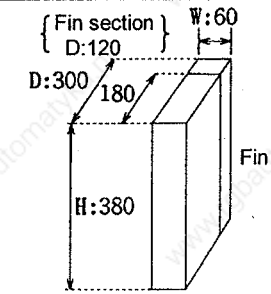
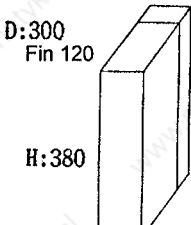
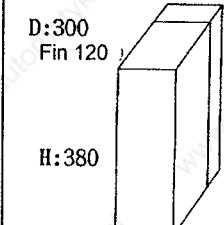
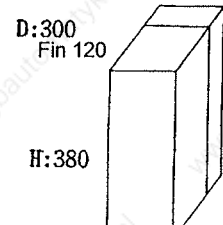
| Outline type | A0/A1 | B1 | C1 | D1 |
|----------------------|--|---|--|---|
| H×W×Dmm | A0: 380×60×180 A1: 380×60×300 | 380×90×300 | 380×120×300 | 380×150×300 |
| Outline drawing (mm) |  <p style="font-size: small;">The A0 type has no fin (Depth: 180)</p> |  |  |  |

3. Unit Installation

|  CAUTION |
|--|
| <ol style="list-style-type: none"> 1. Transport the product with the correct method according to the weight. Failure to do so could lead to injuries. 2. Do not stack products past the limit. 3. Install the unit on a non-combustible material. Direct installation on combustible material or near combustible material could lead to fires. 4. Install the unit according to the instruction manual in a place where the weight can be withstood. 5. Do not get on or place heavy objects on the product. Failure to do so could lead to injuries. 6. Use the unit within the designated environmental condition range. 7. Do not allow conductive matter such as screw or cutting chips or combustible matter such as oil enter the servo amplifier or servomotor. 8. Do not block the intake/outtake ports of the servo amplifier or servomotor. Failure to observe this could lead to faults. 9. The servo amplifier and servomotor are precision machines, so do not drop or apply strong impacts on them. 10. Do not install or operate servo amplifiers or servomotors that are damaged or that have missing parts. 11. When storing the unit for a long time, contact the Service Center or Service Station. |

- (1) Each unit is designed to be installed in a cabinet such as a power distribution box. Avoid installation in direct sunlight, near heat generating objects or outdoors.
 - (2) The inner working environment (temperature, humidity, vibration, atmosphere) of the cabinet must be within the limits given in the "Specifications for each unit". The cabinet for the cutting machine must be a totally closed type cabinet.
 - (3) Make considerations so that inspections and replacement during maintenance is easy. The required space around each unit is shown in the outline dimensions drawing.
 - (4) Each unit generates some heat, so leave a space on the top and bottom when installing other equipment or parts.
- Refer to the outline drawing for the square hole dimensions. In this case, insert packing between the unit and power distribution box. Refer to the following installation examples for the installation of the servo amplifier.

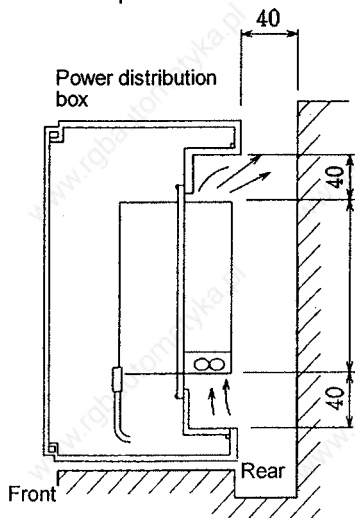

Example 1. Leave space for air flow when the power distribution box is at the rear of the machine.

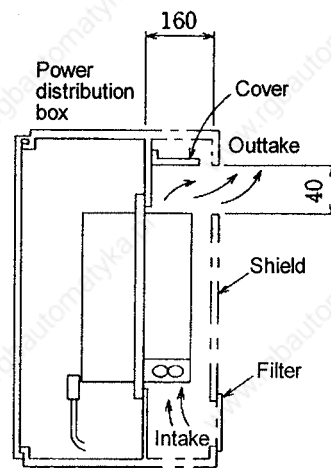

Example 2. When the outdoor air cooling section is to protrude from the power distribution box, make sure that cutting chips, etc., do not enter the outtake section.

3. Unit Installation

⚠ CAUTION

1. Do not hold the front cover when transporting the servo amplifier. The amplifier could drop and lead to injuries.
2. Always observe the installation directions. Failure to do so could lead to faults.
3. Secure the specified distance between the servo amplifier and inner side of the control panel and the other devices. Failure to do so could lead to faults.

Note 1. When installing in a poor environment (factories with large quantities of oil mist), install a filter on the intake section shield shown with the dotted line.

Note 2. When assembling the control panel, make sure that drill cutting chips, etc., do not enter the amplifier.

Note 3. Make sure that oil, water and cutting chips do not enter the amplifier from the control panel clearances or fan on top panel.

Note 4. When using the unit in places having high levels of toxic gases or dust, protect the amplifier by air purging (preventing the entry of toxic gases and dust by feeding clean air from an external source, so that inner pressure of control panel is higher than the outer pressure).

(5) Installation of cooling fan

- 1) Each unit (excluding types without fins) are individually provided with cooling fans (FAN1 shown below). However, to continue operation when the fan stops due to deterioration of the fan's ambient environment, and in terms of maintenance improvement, the user should install the additional fan (FAN2 shown below.).

When using the totally closed type unit installation method and the box structure in which cutting oil and dust, etc., easily enters the unit's fan and fin section (a structure where the fan may stop easily due to the working environment), the user should install a fan at the position indicated as FAN2 below. Forced cooling should then be performed with a velocity of 2m/sec or higher. Also consider the maintainability in this case.

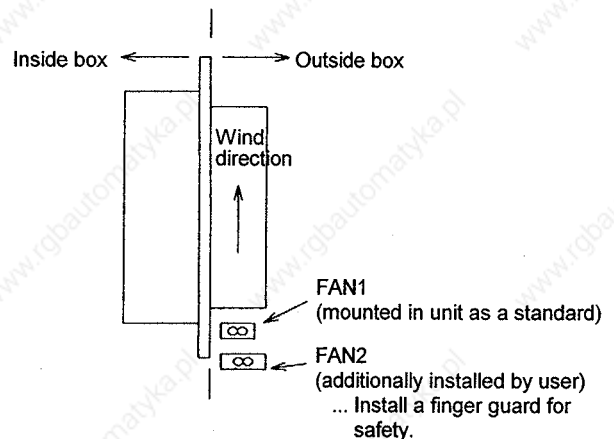

- 2) Due to the structure, heat will tend to accumulate that the top of each unit. Thus, install a fan in the distribution panel to mix the heat at the top of each unit.

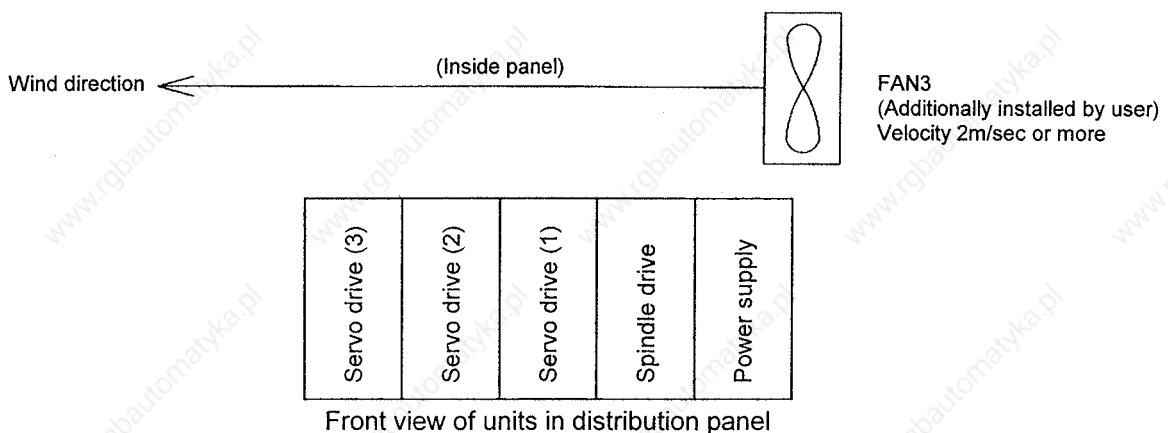

4. Connection of Each Unit

4. Connection of Each Unit

CAUTION

1. Shut off the power on the servo amplifier side if a fault occurs in the servo amplifier. Fires could be caused if a large current continues to flow.
2. Shut off the power with a fault signal. The regenerative resistor could abnormally overheat and cause a fire due to a fault in the regenerative transistor, etc.
3. Use a double circuit configuration that allows the operation circuit for the magnetic brakes to be operated even by the external emergency stop switch when the power is OFF • an alarm has occurred, or the servo ON signal is OFF.
4. Always install the MDS-B-CV-370 external contactor.
Do not share the contactor with the other CV power supply units. Failure to observe this could lead to breakage.
5. The MDS-B-V1-110/150 does not have built-in dynamic brakes. Always use an external dynamic brake unit.

Wire the power supply and main circuit as shown below.
Always use a no-fuse breaker (NF) for the power supply input wire.

Standard connection

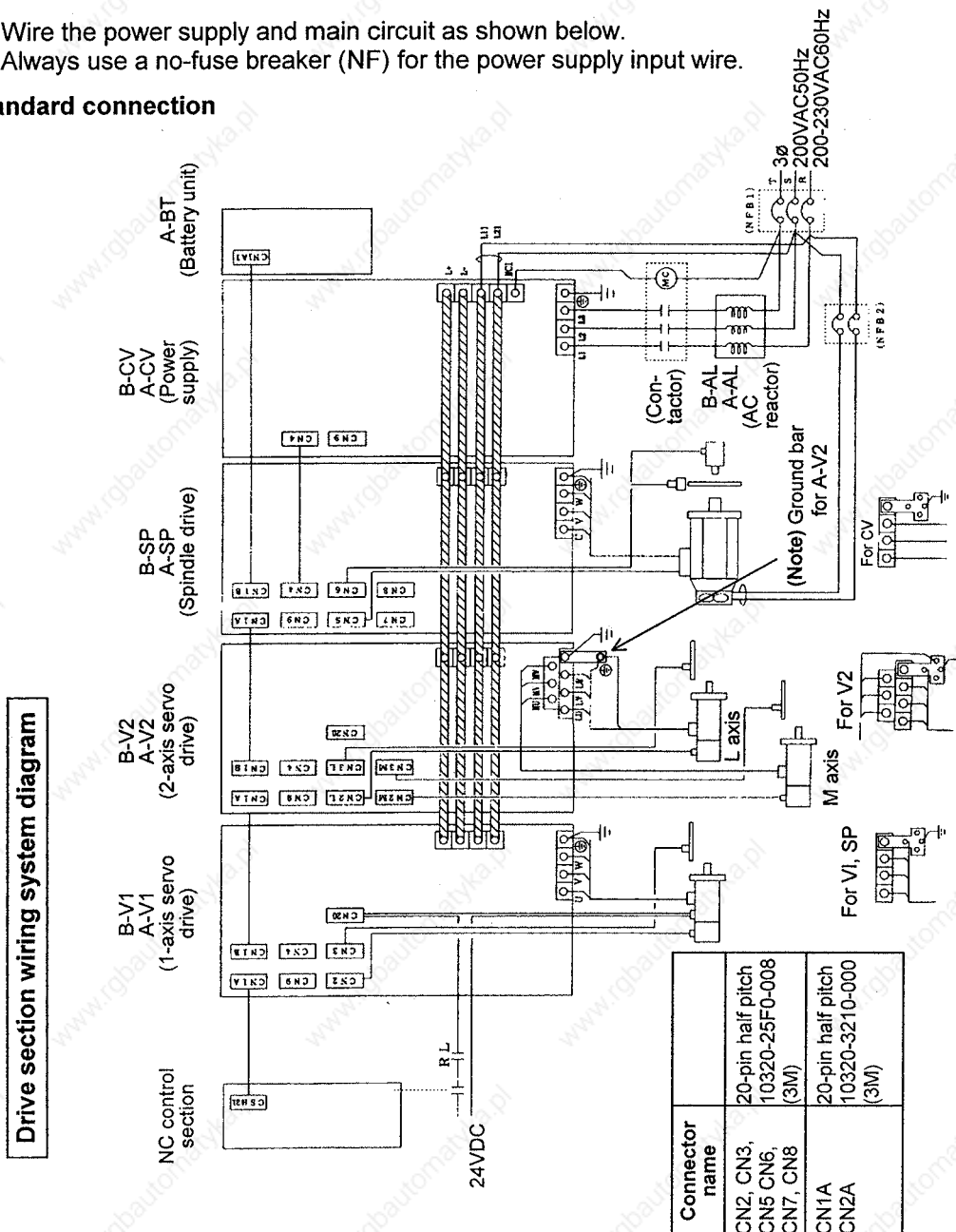

Note 3. Devices (contactor, magnetic brakes, relay) that generate high levels of noise are installed near the power supply and drive unit. If the unit may malfunction, install a surge killer on the noise generating device, so as to suppress the noise.

Note 2. Each unit is shipped with an earth bar, as of production starting April 1995. Wire as shown in the drawings so that the earth wire is not tightened commonly.

4. Connection of Each Unit

4.1 Layout of each unit

Layout the units according to the following reference as a principle.

- (1) When total of spindle motor output and servomotor output is 38kW or less
 Σ (Spindle motor output) + k Σ (servomotor output) \leq 38kW

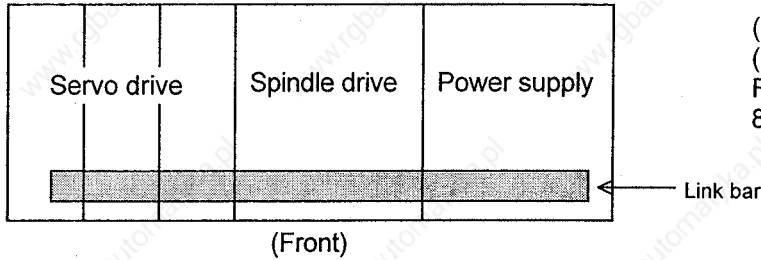

(K = 1 with 1-axis servo)
 (K = 0.7 with 2 or more axes)
 Refer to section
 8. Selection of Capacity for details.

- (2) When total of spindle motor output and servomotor output is larger than 31kW
 Σ (Spindle motor output) + k Σ (servomotor output) > 38kW

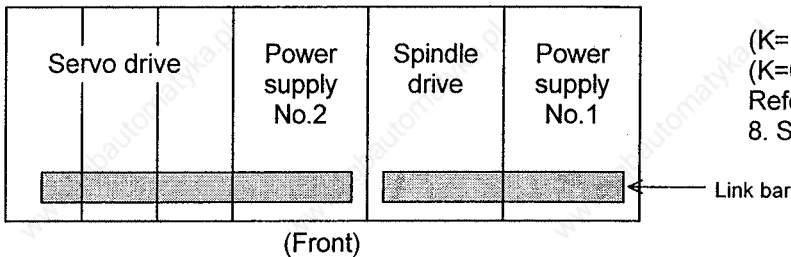

(K=1 with only 1-axis servo)
 (K=0.7 with 2 or more axes)
 Refer to section
 8. Selection of Capacity for details.



CAUTION

Always connect the power supply No. 1 and No. 2 L+ and L- link bars independently.

(Note) The clearance between each unit should generally be 3cm or less.
 If the spindle drive unit and servo drive unit must be separated by more than 3cm,
 observe the conditions listed in section 4.3.

4.2 Link bar specifications

The link bar is the following part, and must be manufactured by the user:

L+, L- — A connection wire used to supply the converter's DC voltage from the power supply unit to each drive unit.

L11, L21 — A connection wire used to supply the 200VAC control power to each unit.

This does not necessary need to be a bar (plate), but can be a wire.

Link bar specifications — The terminal block for link bar connection is the following regardless of the capacity:

{ L+, L- M6 screw
 { L11, L21 M4 screw

An outline connection drawing is shown on the following page for reference.

4. Connection of Each Unit

(1) Outline connection drawing

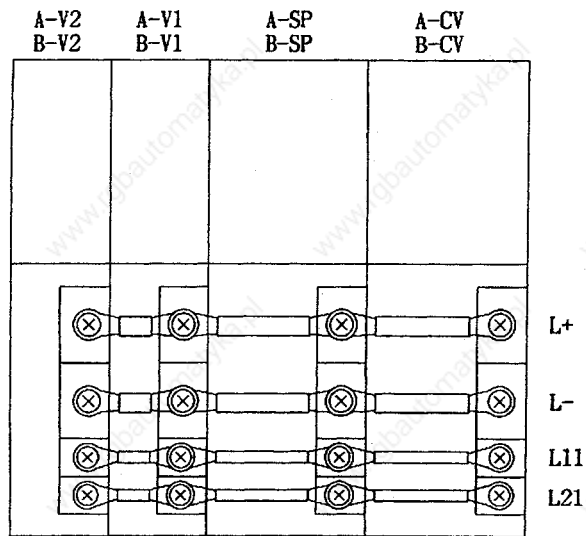

(Note) Mount the terminal cover after wiring as shown above. The terminal cover differs for each unit width. Refer to section 8.3 for selecting the wire size.

4. Connection of Each Unit

4.3 Unit separated layout

When installing vertically, avoid separating the spindle drive unit (A/B-SP) and power supply unit (A/B-CV) as shown in <Example 1> below. Do not separate the 11kw and higher servo drive units either. When using both spindle drive units and 11kw and higher servo drive units, arrange them next to the power supply unit in the following order of priority.

V1-150 > V1-110 > SP-300 > SP-260 > SP-220 > SP-185 > SP-150

For example, when using a combination of SP-260 and V1-150, place the V1-150 next to the power supply unit, and the SP-260 next to that.

The 9kW and below servo drive unit can be installed vertically as shown in <Example 2>. Note that the relay link bar length must be 50cm or less, and two bars must be bundled.

<Example 1> NG

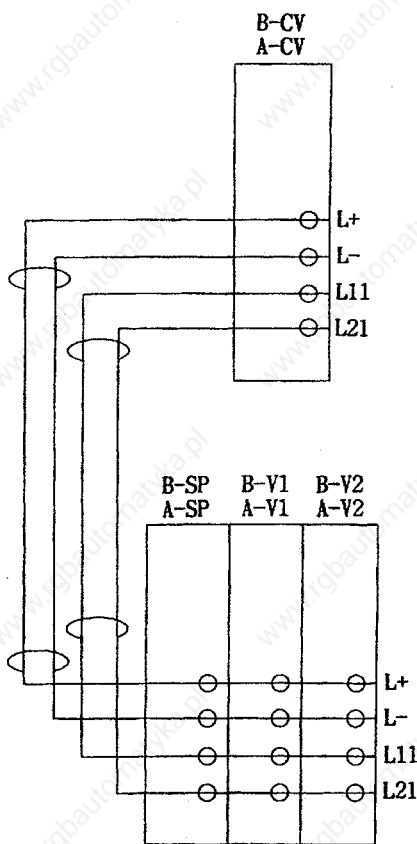

<Example 2> OK

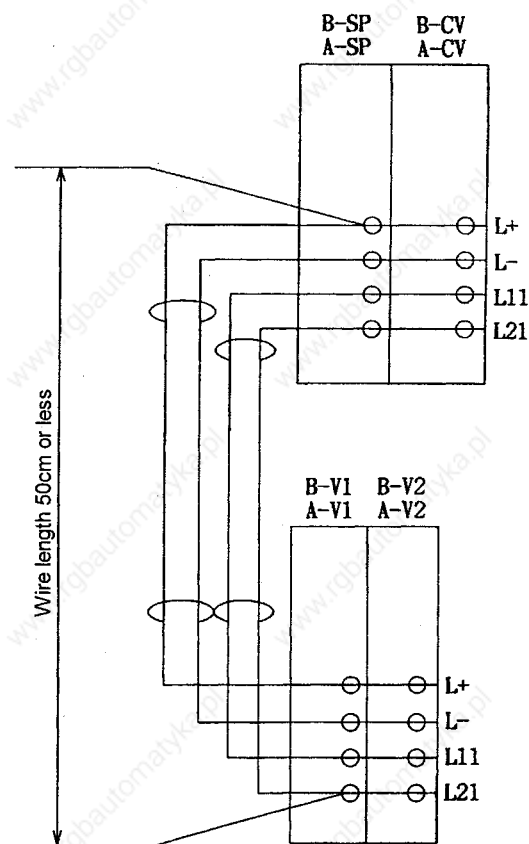

(Note) The above details also apply when separating the units to the left and right and installing.

4. Connection of Each Unit

4.4 Precautions for installing multiple power supply units (Refer to section 8.1 ^(Note 4))

(1) When not using a contactor

⚠ Always use this wiring when using the MDS-B-CV-370.

The rush circuit and contactor operation sequence of the MDS-B-CV-370 differs from the other power supply units (A/B-CV). Thus, always install an independent contactor. If the contactor is not used or if shared with other power supply units, damage will occur.

A system in which a power supply unit (A/B-CV (No. 1)) is installed for the spindle drive unit and one (A/B-CV (No. 2)) is installed for the servo drive unit is explained as a representative example of multiple power supply unit installation. The same connections are used for other multiple installation systems.

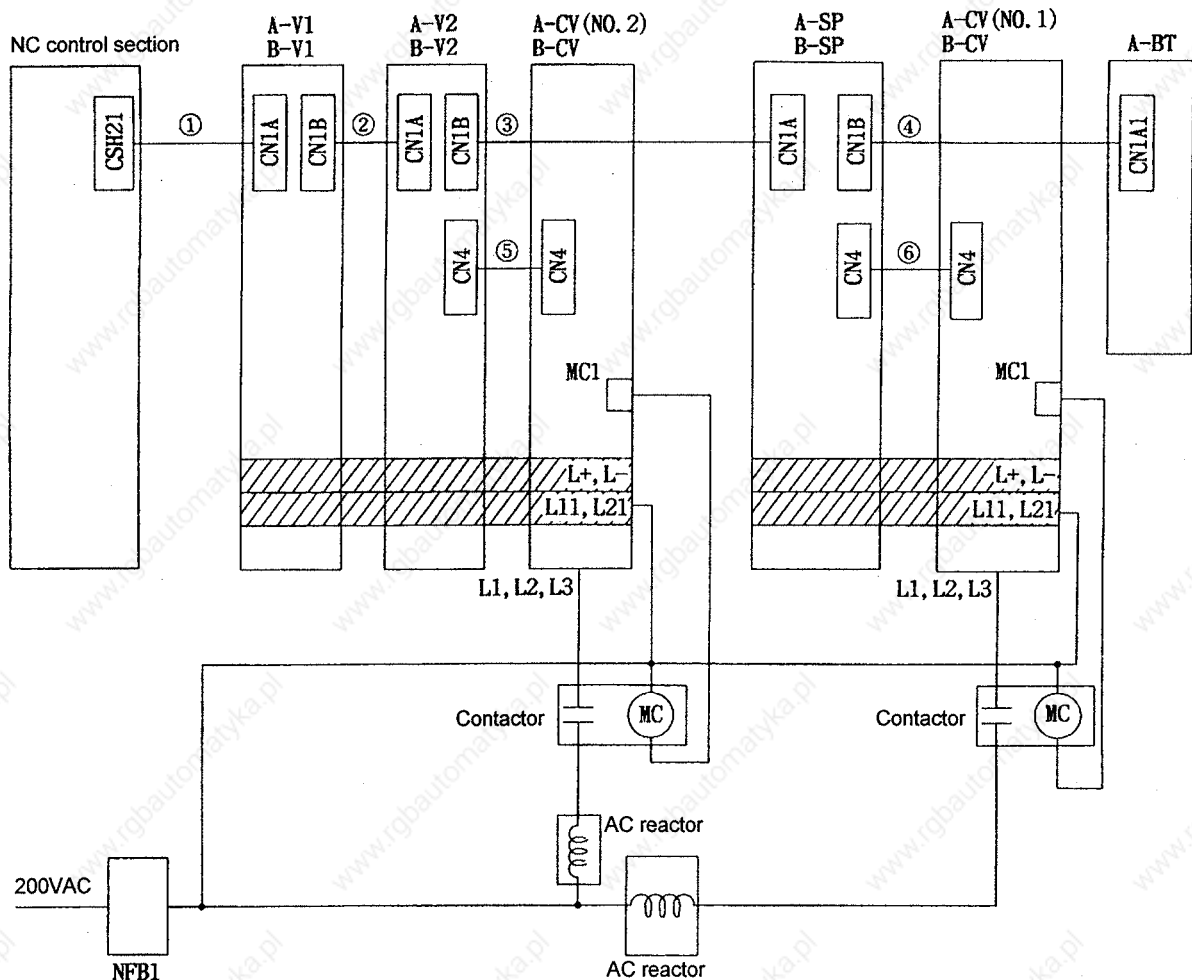

Fig. 1

- 1) Connection of NC communication cable
 - <1> When battery unit (A-BT) is required (when absolute position detection specifications are used)
 - Connect with the lines ① to ④ above.
 - <2> When battery unit (A-BT) is not required (when absolute position detection specifications are not used).
 - The ④ connection cable and battery unit will not be required so insert a terminator (A-TM) into the terminating axis CN1B (A/B-SP above).
- 2) Connection of communication cable between drive unit and power supply unit
 - Connect the ⑥ cable to A/B-CV (No. 1) and the ⑤ cable to A/B-CV (No. 2) as shown above.

4. Connection of Each Unit

- 3) Connection of L+, L-, L11 and L21 link bars
As shown in Fig. 1, the link bar for A/B-CV (No. 1) and for A/B-CV (No. 2) are connected independently. Make sure that neither of the link bars are short circuited and connected.
- 4) Connection of AC reactor
Always use one AC reactor per power supply unit, and install the AC reactor for the A/B-CV (No. 1) and A/B-CV (No. 2) separately as shown in Fig. 1.
- 5) Connection of contactor
When using the MDS-B-CV-370, a contactor cannot be used, so install separately as shown in Fig. 1.

(2) To share contactors

In this section, the system in which the power supply unit (A/B-CV (No. 1)) for the spindle drive unit, and the power supply unit (A/B-CV (No. 2)) for the servo drive unit are installed as shown below is explained as a special example of using one contactor with multiple power supply units. The same connection is used for multiple systems. When sharing the contactor, set the power supply unit that does not control the contactor as "No contactor". At this time some alarms (ground fault, external contact welding) will be invalidated.

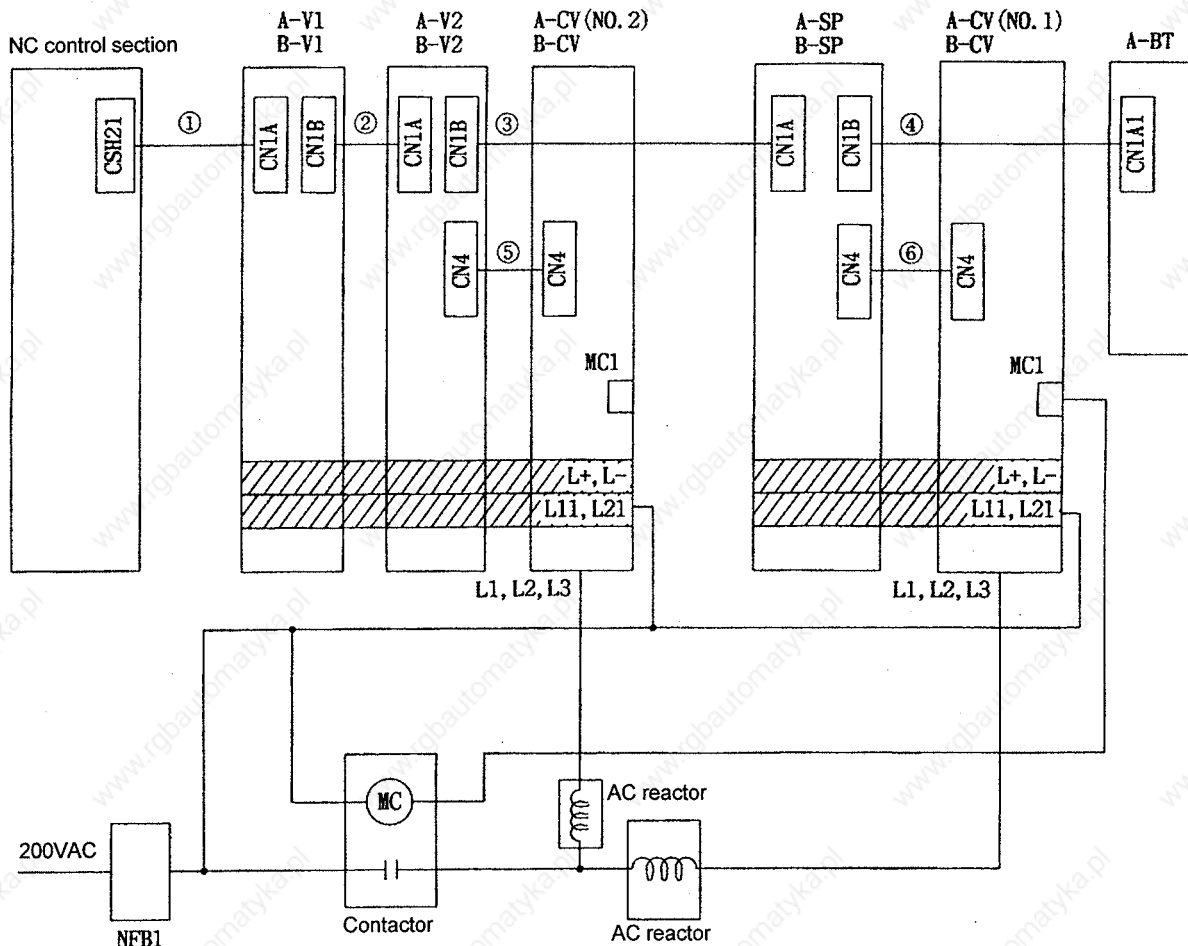

- 6) Connection and selection of NFB1, contactor and AC reactor
For the NFB and contactor, basically only one unit each needs to be installed for the A/B-CV (No. 1) and A/B-CV (No. 2) as shown in Fig. 1. However, each power supply should be provided with an AC reactor, so separately install the AC reactors for the A/B-CV (No. 1) and A/B-CV (No. 2) as shown in Fig. 1.
- 7) Connection of MC1 terminal (power supply unit)
If one batch connector is installed as shown in Fig. 1, the contactor coil exciting terminal (MC1) is connected only to the power supply unit (=A/B-CV (No.1)) connected to the terminating axis.

4. Connection of Each Unit

4.5 Precautions for installing only one power supply unit for the 2CH communication specifications with the NC (For 2-system control)

※ Note that this method cannot be used with the A-CR.

The following systems will be explained in this section. The other 2CH systems also use the same specifications.

- CH1 A/B-V1 + A/B-V2
- CH2 A/B-V2 + A/B-SP

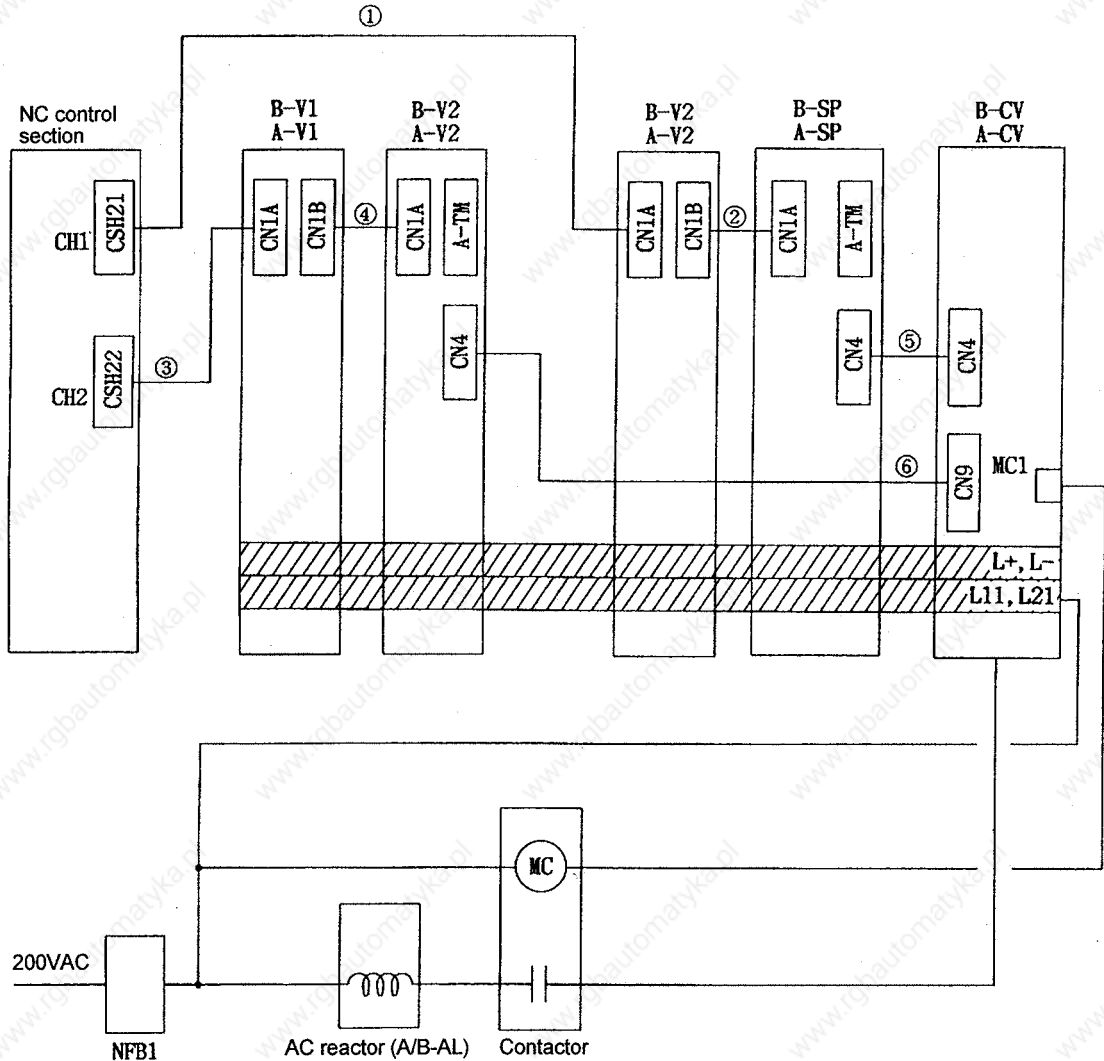

Fig. 2

- 1) Connection of NC communication cable
 - <1> CH1
Connect with the lines ① to ② shown in Fig. 2.
 - <2> CH2
Connect with the lines ③ to ④ shown in Fig. 2.
- 2) Connection of communication cable between drive unit and power supply unit
 - <1> CH1
Connect from the CH1 terminating axis (A/B-SP in Fig.2) with the line ⑤. The pin assignments for cable ⑤ are the same as the standard specifications. (Refer to section 5.2.1.)
 - <2> CH2
Connect from the CH2 terminating axis (A/B-V2 in Fig. 2) with the line ⑥. The pin assignments for cable ⑥ are the same as the standard specifications.

4. Connection of Each Unit

4.6 Connection of battery unit

Unit configuration

① Without battery unit

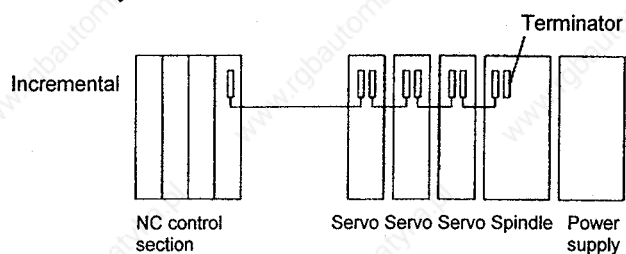

② With battery unit

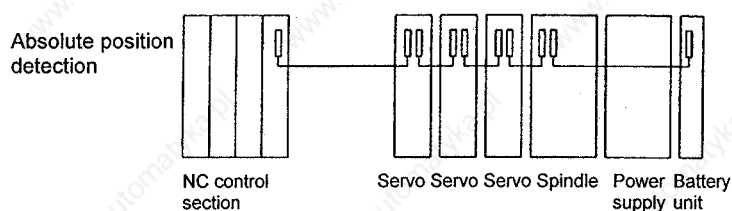

The terminator is not required for the absolute position detection.
(The connector is built in the battery unit.)

The battery unit model is as follows according to the battery capacity (quantity). Select so that the No. of axis for absolute position detector is less than the No. of batteries.

| | | |
|-----------|---|--|
| MDS-A-BT- | 2 | } No. of batteries (≥ No. of absolute value axes) |
| | 4 | |
| | 6 | |
| | 8 | |

※ The battery does not differ for the MDS-B Series, so prepare the conventional MDS-A-BT-□ type.

5. Drive Section Connector and Cable Specifications

5.1 Half pitch cable connection system

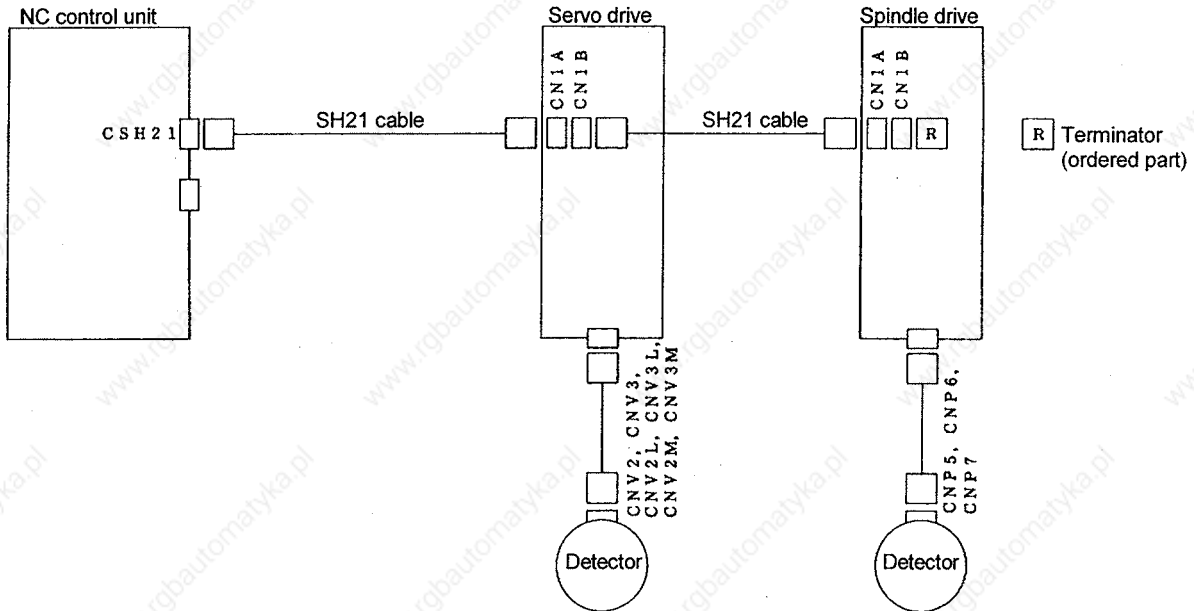

| Cable name | Connector name on controller side (Maker) | Recommended connector name on cable side (Maker) | Cable maker | Cable creation tool (Maker) |
|--|---|---|--|--|
| SH21 cable | 10220-52A2JL 20220-52A2JL | Shell (Crimp type) : 10320-3210-000(3M) Plug (Crimp type) : 10120-6000EL (3M) | UL2789 AWG28 (DDK) IOPVV-SB AWG28X10P (3M) | Press machine unit (with gauge block) : 3794-1000 Locator plate : 3795-1A Platen : 3795-2A Cutting unit : 3795-3A Fixture unit : 3796-1A Fixture unit : 3796-2A Fixture unit : 3796-5A Fixture block : 3796-3A Cable clamp : 3796-4 |
| Servo drive CNV2, CNV3, CNV2L, CNV3L, CNV2M, CNV3M Each cable | Same as above | (1)Controller side Plug (soldered-type) : 10120-3000VE (3M) Shell (soldered-type) : 10320-52F0-008 (3M) (2)Detector side → ① (Straight) 2-type Cannon connector : MS3106B22-14S (Japan Aviation Electronics) Connector clamp : MS3057-12A (Japan Aviation Electronics) ② (Right angle) 3-type Cannon connector : MS3108B22-14S (Japan Aviation Electronics) Connector clamp : MS3057-12A (Japan Aviation Electronics) ③ (Amplifier terminal) E-type Amplifier terminal : V1.25-4 | TSI-91026 2PX0.3SQ+10PX0.2SQ (DDK) The HA053/13 motor built-in encoder uses a different cannon plug. (Refer to section 5.2.3 (1).) | |

5. Drive Section Connector and Cable Specifications

Half pitch cable connection system (continued)

| | Cable name | Connector name on controller side (Maker) | Recommended connector name on cable side (Maker) | Cable maker | Cable creation tool (Maker) |
|---------------|------------|---|--|---|-----------------------------|
| Spindle drive | CNP5 | 20220-52A2JL | (1)Controller side Plug (soldered-type) : 10120-3000VE (3M) Shell (soldered-type) : 10320-52F0-008 (3M) (2)Detector side Connector : AMP-350720-1 (Japan Amplifier) Pin : AMP-350689-1 (Japan Amplifier) | TP-91026 2PX0.3SQ+10PX0.2SQ (DDK) | — |
| | CNP6 | Same as above | (1)Controller side Plug (soldered-type) : 10120-3000VE (3M) Shell (soldered-type) : 10320-52F0-008 (3M) (2)Detector side ① Magnesensor : TRC116-12A10-7F10.5 (Tajimi Musen) ② Encoder : MS3106A20-29S (Cannon) | Same as above | — |
| | CNP7 | Same as above | (1)Controller side Plug (soldered-type): 10120-3000VE (3M) Shell (soldered-type): 10320-52F0-008 (3M) (2)Detector side MS3106A20-29S (Cannon) | Same as above | — |

Cable name system

CN□□□□ - □□ - □ - □

| | |
|---------------------------------|--|
| Connector fixed type | None: One-touch type lock S : Screw type lock |
| Connector type | E : E-type (crimp terminal on lead end) 2 : 2-type (cannon plug straight type or designated connector) 3 : 3-type (cannon plug L type) |
| Axis No. (Axis 1 to 9) | 1~9 : Axis 1 ~ 9 |
| System No. | None: Axis 1 system 2 : Axis 2 system ↓ 5 : Axis 5 system P : PLC axis |
| Servo and spindle detector type | None: Servo standard detector or spindle PLG S : Servo small capacity detector (HA053/HA13) F : Servo special motor (HA-FH053C-Y) A : Spindle shaft type encoder B : Spindle built-in type encoder M : Spindle magnesensor |
| Connection connector | 2 : CN2L or CN2M (servo drive: semi-closed) 3 : CN3L or CN3M (servo drive: closed) 5 : CN5 (spindle drive: speed detection) 6 : CN6 (spindle drive: orientation) 7 : CN7 (spindle drive: C axis) 67 : CN6 + CN7 (spindle drive: orientation + C axis) 71 : CN7 (spindle drive: C axis) + CES11 (NC: threading) |
| Model | V : For servo P : For spindle |

5. Drive Section Connector and Cable Specifications

5.2 Cable details

CAUTION

Do not mistake the connection when manufacturing the detector cable. Failure to observe this could lead to runaway.

5.2.1 Communication cable SH21 (semi ordered product)

| Application | Connector 1 | Connector 2 | L |
|---------------------------|-------------|-------------|-----------------|
| NC ↔ drive unit | CSH21/22 | CN1A | |
| Drive unit ↔ drive unit | CN1B | CN1A | Standard: 350mm |
| Drive unit ↔ power supply | CN4 | CN4 | Standard: 350mm |
| Drive unit ↔ battery unit | CN1B | CN1A1 | Standard: 350mm |

| Part No. | Part name | Model | Maker |
|----------|---------------------------|--------------------------------|-------|
| 000 | | | |
| 101 | Connector (plastic shell) | 10320-3210-000 | 3M |
| 102 | Cable | 10PVV-SB AWG28×10P(BK0-NC9072) | 3M |
| 103 | Connector (plug) | 10120-6000EL | 3M |

5.2.2 Terminator A-TM (ordered part)

| Model |
|-------|
| A-TM |

5. Drive Section Connector and Cable Specifications

5.2.3 Servo drive unit detector cable

(1) HA053/13 motor built-in detector cable

(a) ① CNV2, CNV3, CNV2L, CNV2M, CNV3L, CNV3M (cable length ≤ 20m)

| Part No. | Part name | Model | Qty/type | | | Maker |
|----------|-------------------|-----------------------------|----------|--------|--------|---------------------------------|
| | | | 2-type | 3-type | E-type | |
| 101 | Connector (shell) | 10320-52F0-008 | 1 | 1 | 1 | 3M |
| 102 | Connector (plug) | 10120-3000VE | 1 | 1 | 1 | 3M |
| 103 | | | | | | |
| 104 | Cable | TS-91026 2P×0.3SQ+10P×0.2SQ | 1 | 1 | 1 | DDK |
| 105 | Cannon connector | MS3108B20-29S | | 1 | | DDK, Japan Aviation Electronics |
| 106 | Connector clamp | MS3057-12A | 1 | 1 | | DDK, Japan Aviation Electronics |
| 107 | | | | | | |
| 108 | Cannon connector | MS3106B20-29S | 1 | | | DDK, Japan Aviation Electronics |

Amplifier connector
F-DPEVSB 2P×0.3SQ+10P×0.2SQ

| Pin No. | Color |
|---------|--------|
| 2 | Green |
| 12 | White |
| 3 | Red |
| 13 | White |
| 4 | Purple |
| 14 | White |
| 6 | Yellow |
| 16 | Brown |
| 7 | Green |
| 17 | Brown |
| 8 | Red |
| 18 | Brown |
| 9 | Purple |
| 19 | Brown |
| 10 | Blue |
| 20 | Black |
| 1 | Black |
| 11 | Yellow |

Connect the shield to the connector case

Detector connector
Built-in encoder

| Pin No. | Phase |
|---------|----------------|
| A | A-phase |
| B | A-phase |
| C | B-phase |
| D | B-phase |
| F | Z-phase |
| G | Z-phase |
| H | U-phase |
| J | U-phase |
| K | V-phase |
| L | V-phase |
| M | W-phase |
| T | W-phase |
| E | |
| S | ((+5V)) |
| R | GND |
| N | Case grounding |

B24-9
() not required for scale
(()) not required for 5V built-in type scale

Length L (L ≤ 20m)

* The HA053/13 does not have a thermal relay built into the detector.
* Refer to "5.2.7 Cable materials" for details on the cable wire material.

(Note)
The connector shell on the servo drive unit is the 3M "10320-52F0-008" but, this is a shell with a one-touch locking mechanism that does not require screw locking. When ordering the cables from Mitsubishi, the shell "10320-52F0-008" with this one-touch lock mechanism will be used. However, if the cable is to be manufactured by the user, the shell "10320-52A0-008" (3M) with the screw lock mechanism can be used instead of the above shell.

(b) ② CNV2, CNV3, CNV2L, CNV2M, CNV3L, CNV3M (20m < cable length ≤ 30m)

Amplifier connector
F-DPEVSB 2P×0.3SQ+10P×0.2SQ

| Pin No. | Color |
|---------|--------|
| 2 | Green |
| 12 | White |
| 3 | Red |
| 13 | White |
| 4 | Purple |
| 14 | White |
| 6 | Yellow |
| 16 | Brwbn |
| 7 | Green |
| 17 | Brwbn |
| 8 | Red |
| 18 | Brwbn |
| 9 | Purple |
| 19 | Brwbn |
| 10 | Blue |
| 20 | Black |
| 1 | Black |
| 11 | Yellow |

Fix the shield to the connector case

Detector connector
Built-in encoder

| Pin No. | Phase |
|---------|----------------|
| A | A-phase |
| B | A-phase |
| C | B-phase |
| D | B-phase |
| F | Z-phase |
| G | Z-phase |
| H | U-phase |
| J | U-phase |
| K | V-phase |
| L | V-phase |
| M | W-phase |
| T | W-phase |
| E | |
| S | ((+5V)) |
| R | GND |
| N | Case grounding |

B24-9
() not required for scale
(()) not required for 5V built-in type scale

Length L (20 < L ≤ 30m)

* The HA053/13 does not have a thermal relay built into the detector.
* Refer to "5.2.7 Cable materials" for details on the cable wire material.

(Note 1)
For the 11.20 pin connection on the amplifier side connector, bundle the cable wires, connect the wires by soldering, and insulate with a heat contraction tube.

(Note) The cable length must be 30m or less.

5. Drive Section Connector and Cable Specifications

(2) Cables for OHE25K-□, OHA25K-□, OSE104□, OSA104□, OSE105□ and OSA105□ detectors

(a) ① CNV2, CNV3, CNV2L, CNV2M, CNV3L, CNV3M (cable length ≤ 20m)

| Part No. | Part name | Model | Qty/type | | | Maker |
|----------|-------------------|-----------------------------|----------|--------|--------|---------------------------------|
| | | | 2-type | 3-type | E-type | |
| 101 | Connector (shell) | 10320-52F0-008 | 1 | 1 | 1 | 3M |
| 102 | Connector (plug) | 10120-3000VE | 1 | 1 | 1 | 3M |
| 103 | | | | | | |
| 104 | Cable | TS-91026 2P×0.3SQ+10P×0.2SQ | 1 | 1 | 1 | DDK |
| 105 | Cannon connector | MS3108B22-14S | | 1 | | DDK, Japan Aviation Electronics |
| 106 | Connector clamp | MS3057-12A | 1 | 1 | | DDK, Japan Aviation Electronics |
| 107 | | | | | | DDK, Japan Aviation Electronics |
| 108 | Cannon connector | MS3106B22-14S | 1 | | | |

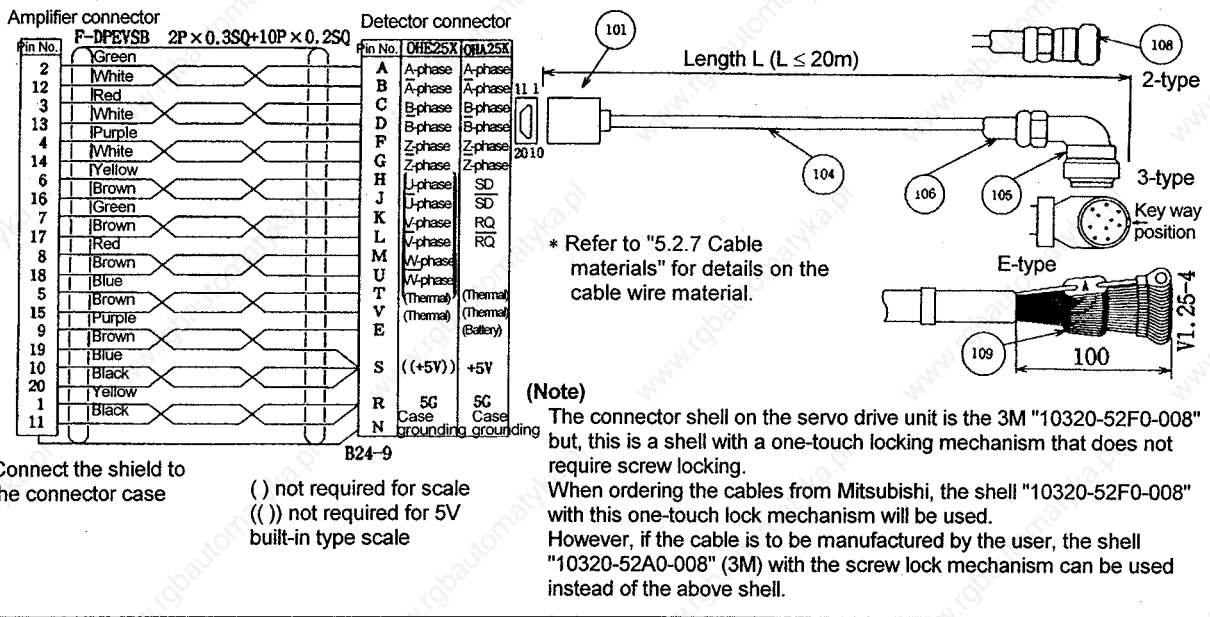

(b) ② CNV2, CNV3, CNV2L, CNV2M, CNV3L, CNV3M (20m < cable length ≤ 30m)

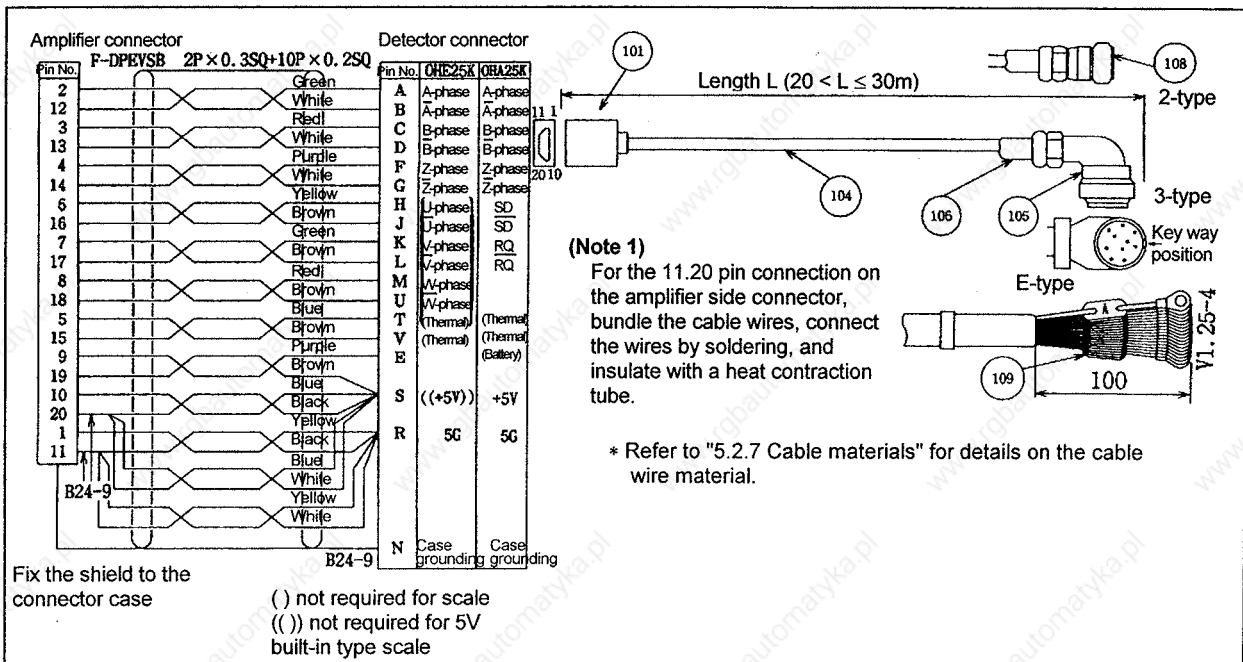

(Note) The cable length must be 30m or less.

5. Drive Section Connector and Cable Specifications

5.2.4 Brake cable

(1) 9kW and below Mechanical brakes

| Part No. | Part name | Model | Maker |
|----------|-----------|------------|-----------------|
| 101 | Connector | 1-178128-3 | Japan Amplifier |
| 102 | Contact | 1-175218-2 | Japan Amplifier |

Line size : 0.5 ~ 1.25SQ

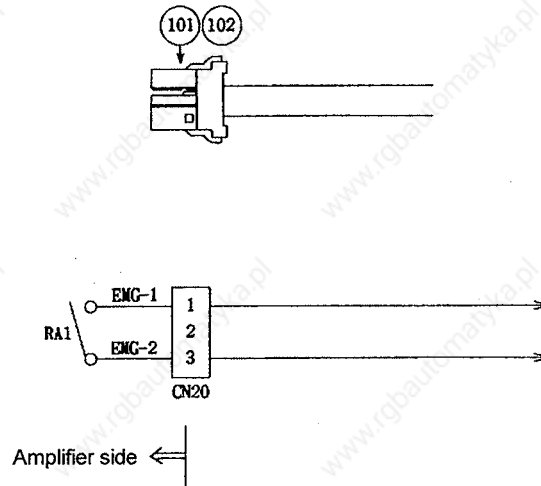

(2) 11kW, 15kW Mechanical brakes and dynamic brakes

| Part No. | Part name | Model | Maker |
|----------|-----------|------------|-----------------|
| 101 | Connector | 1-178128-3 | Japan Amplifier |
| 102 | Contact | 1-175218-2 | Japan Amplifier |

Line size : 0.5 ~ 1.25SQ

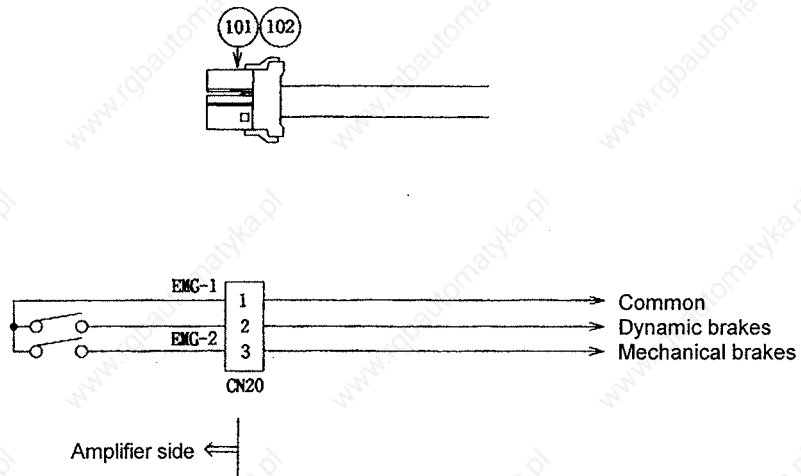

5. Drive Section Connector and Cable Specifications

5.2.5 Communication cable SH21 connector

(a) 10320-3210-000

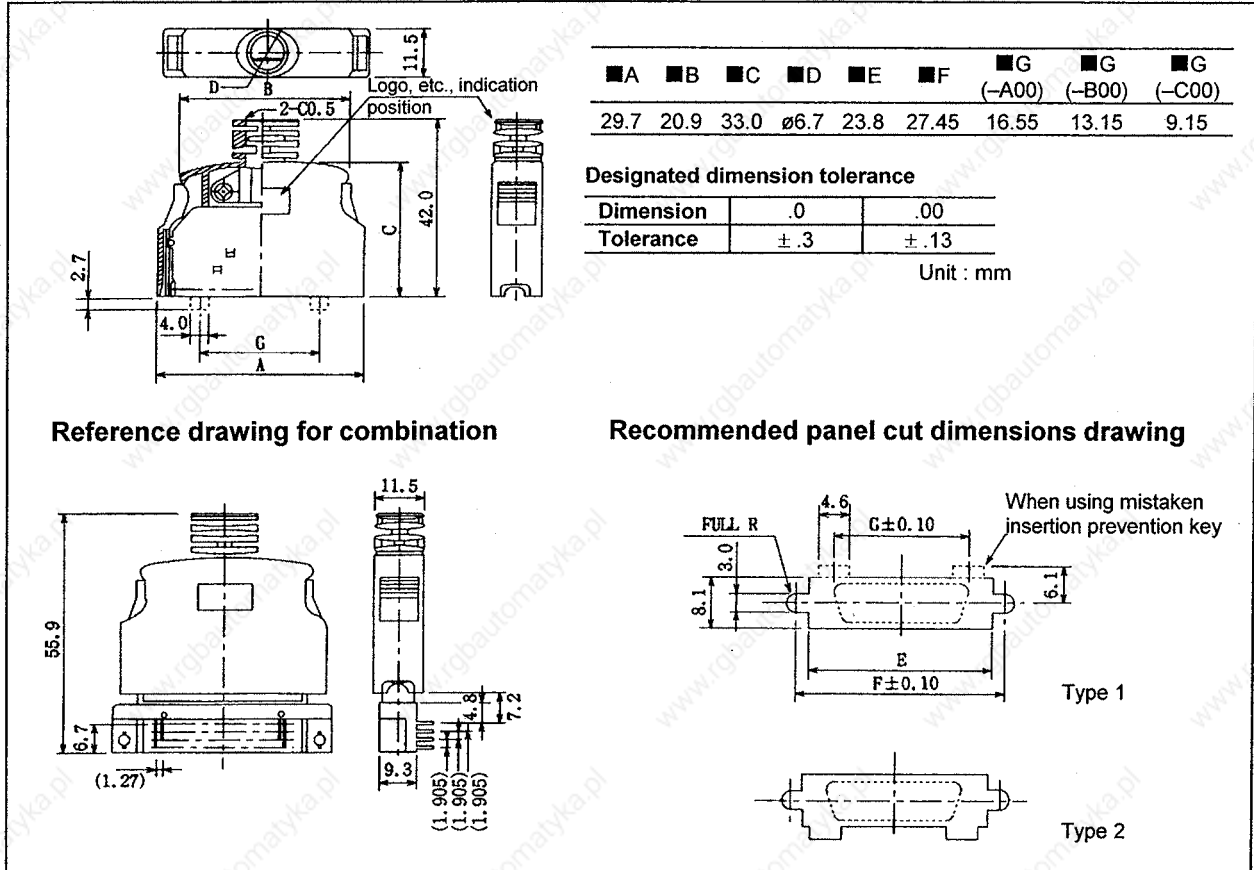

(b) 10320-52F0-008

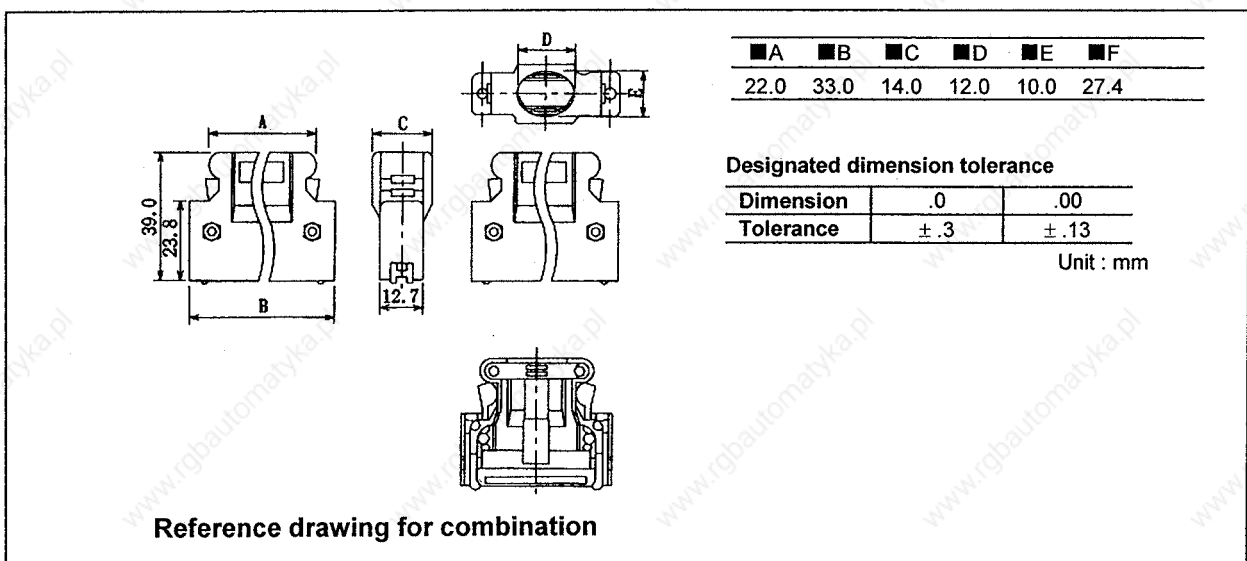

5. Drive Section Connector and Cable Specifications

5.2.6 Cannon plug for servomotor detector

1. Standard plug

- (1) Angle plug MS3108B20-29S (for HA053/13 motor built-in encoder)

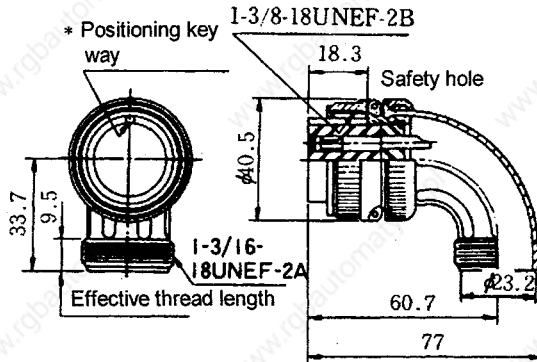

* Key position of cannon connector : motor flange direction

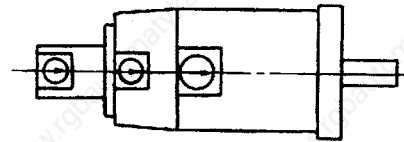

- (2) Straight plug MS3106B20-29S (for HA053/13 motor built-in encoder)

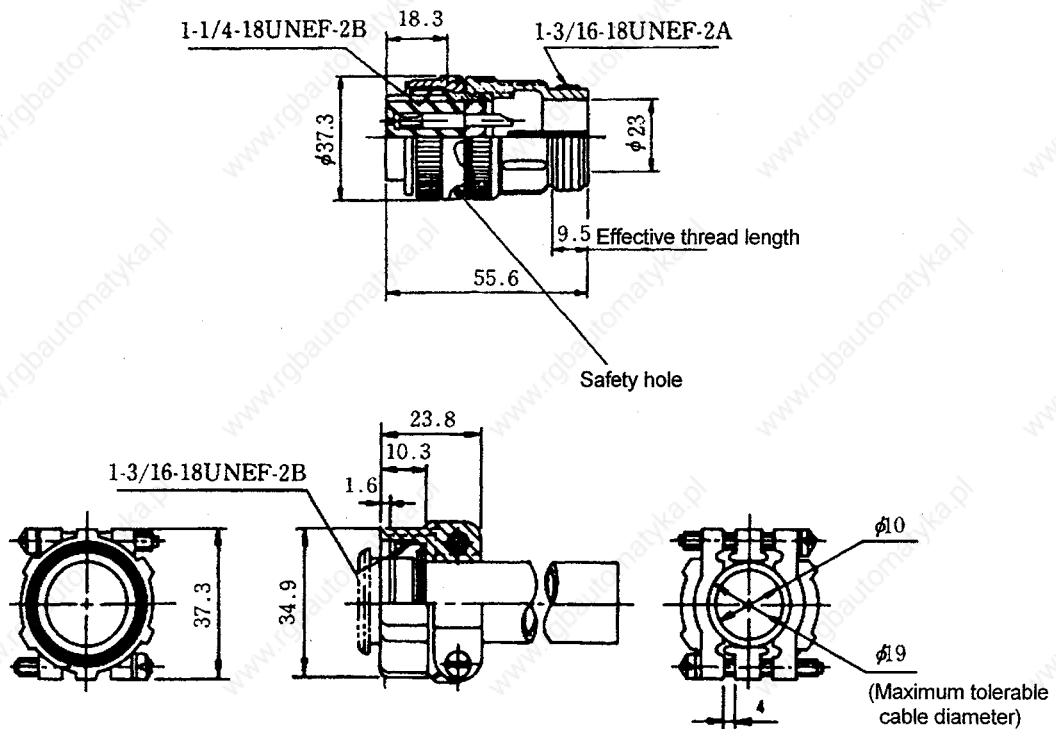

The servo drive unit and the motor are not provided with connector and cables.

5. Drive Section Connector and Cable Specifications

- (3) Angle plug MS3108B22-14S
(for OHE25K-□/ OHA25K-□/ OSE104□/ OSA104□/ OSE105□/ OSA105)

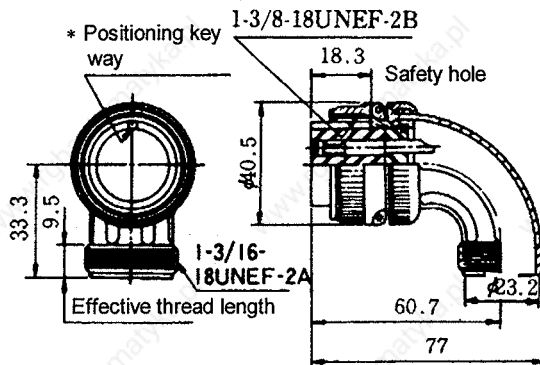

* Key position of cannon connector : motor flange direction

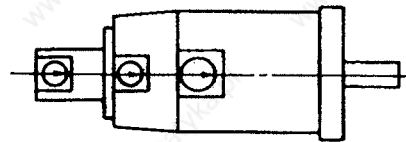

- (4) Straight plug MS3106B22-14S
(for OHE25K-□/ OHA25K-□/ OSE104□/ OSA104□/ OSE105□/ OSA105)

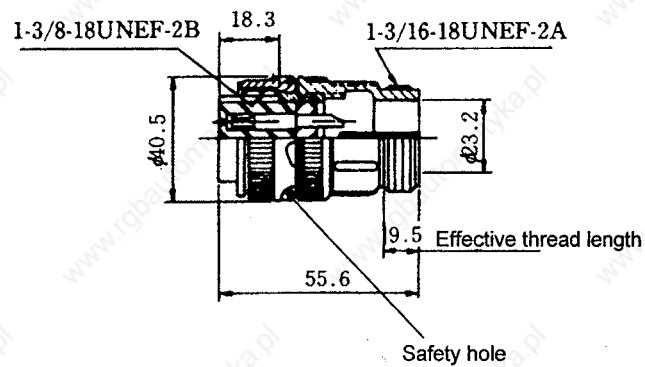

The servo drive unit and the motor are not provided with connector and cables.

5. Drive Section Connector and Cable Specifications

2. JIS corresponding plugs (Hirose)

If the JIS B6015 standards must be followed, use the following connectors.

(JIS B6015 standards)

- In accordance to MIL-C-5015 (US military standards)
- Structure in which grounding is connected before other circuits are connected, and shut off after other circuits are shut off.
- Waterproof and oil-proof.

(1) Angle plug H/MS3108B20-29S-N (for HA053/13 motor built-in encoder)

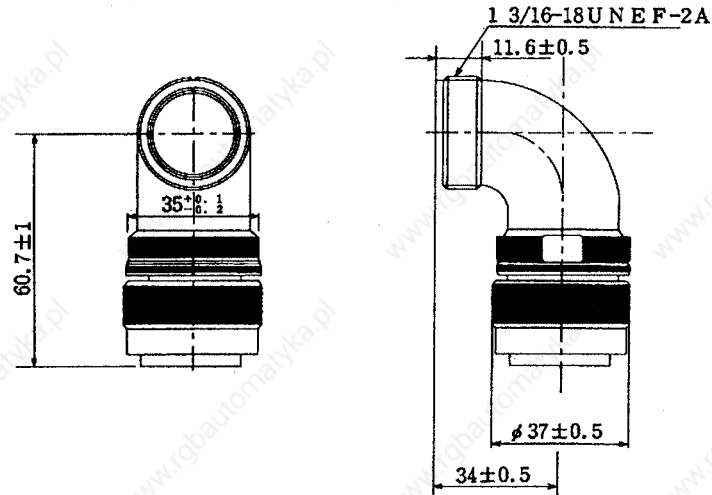

(2) Straight plug H/MS3106A20-29S-N (for HA053/13 motor built-in encoder)

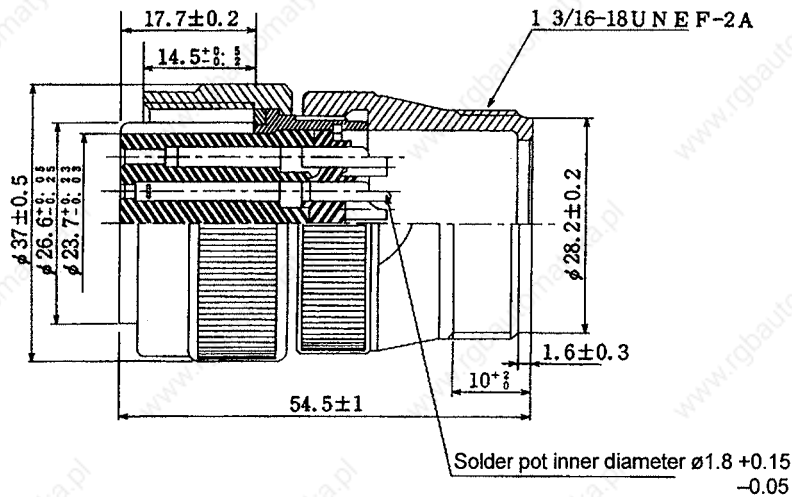

5. Drive Section Connector and Cable Specifications

- (3) Angle plug H/MS3108B22-14S-N
 (for OHE25K-□/ OHA25K-□/ OSE104□/ OSA104□/ OSE105□/ OSA105)

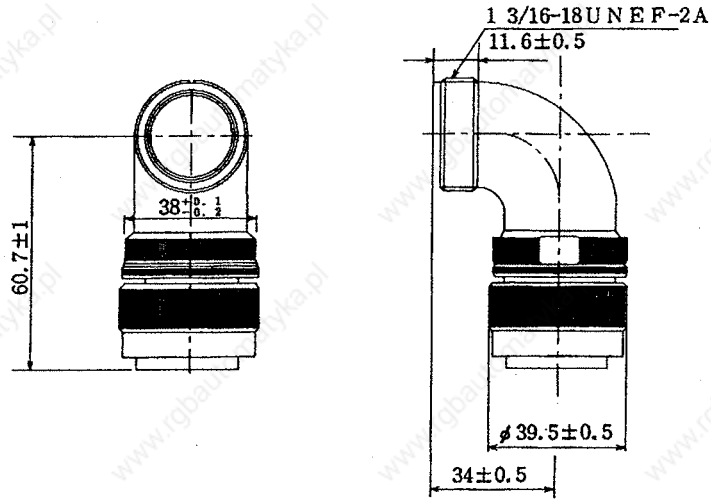

- (4) Straight plug H/MS3106A22-14S-N
 (for OHE25K-□/ OHA25K-□/ OSE104□/ OSA104□/ OSE105□/ OSA105)

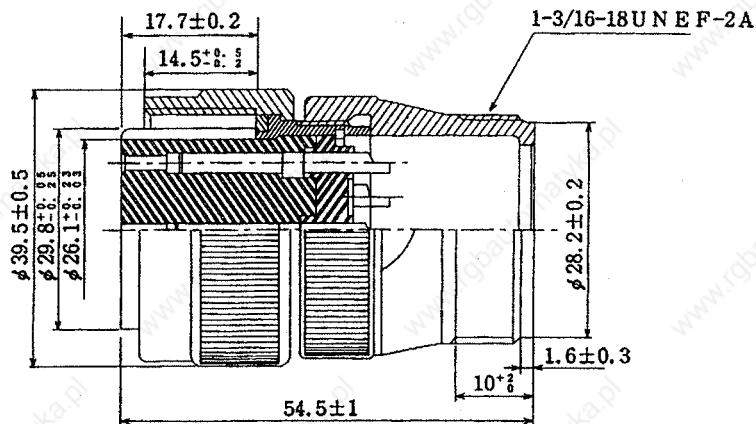

5. Drive Section Connector and Cable Specifications

5.2.7 Cable materials

When the wiring length between the motor and the amplifier is long and the motor moves, high bending resistant cables should be used.

The following table represents the typical types of the cables made by Mitsubishi.

12 pair shield cable

Model: TS-91026 $0.3\text{mm}^2 \times 2 \text{ pairs} + 0.2\text{mm}^2 \times 10 \text{ pairs}$
(DDK)

| Type | No. of wire cores and size | Finished outer diameter | Characteristics of one wire | | | | Bending resistance property | Color |
|------|------------------------------|-------------------------|-----------------------------|---------------------------------|-------------------|---|--|-------|
| | | | Configuration | Conductor resistance | Withstand voltage | Insulation resistance | | |
| A | 2 pairs 0.3mm^2 | 11.6mm | 60/0.08mm | $63\Omega/\text{km}$ or less | 750VAC/min. | $60\text{M}\Omega/\text{km}$ or more | Approx. 140×10^4 times at R200 | Black |
| B | 10 pairs 0.2mm^2 | | 40/0.08mm | $95\Omega/\text{km}$ or less | | | | |

Structural drawing

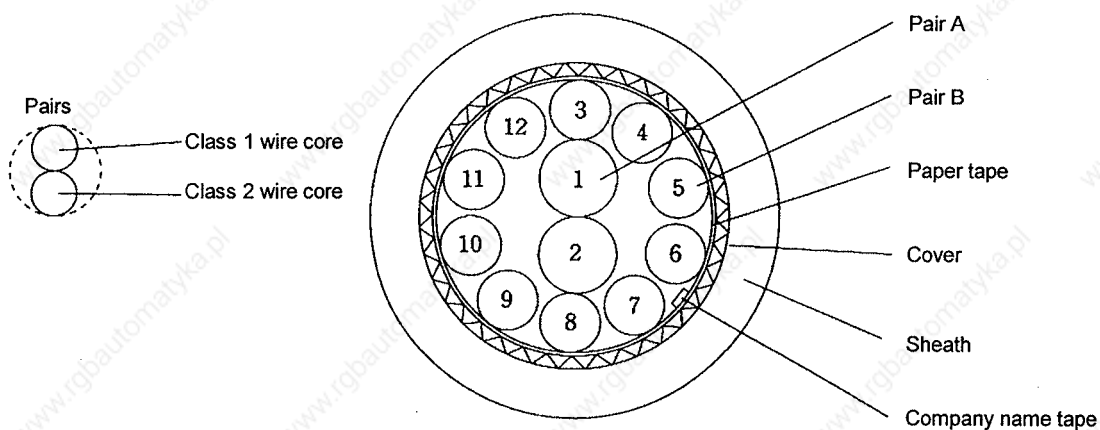

Core identification table

| Type of pair | A | | B | | | | | | | | | |
|------------------------------------|-------|--------|-------|-------|--------|-------|--------|-------|-------|--------|-------|--------|
| | 1 | 2 | 3 | 4 | 5 | 6 | 7 | 8 | 9 | 10 | 11 | 12 |
| Class 1 wire core insulation color | Blue | Yellow | Green | Red | Purple | Blue | Yellow | Green | Red | Purple | Blue | Yellow |
| Class 2 wire core insulation color | White | White | White | White | White | Brown | Brown | Brown | Brown | Brown | Black | Black |

5. Drive Section Connector and Cable Specifications

5.2.8 Cable protection tube (Measures against noise)

When noise cannot be prevented or the noise-proof property is laxed, the following metal tube should be selected and the signal cable should be passed through the tube.

The tube is also used when the cable sheath is cut or abraded by cutting chips. In addition, on the detector side, the cable clamps MS3057 cannot be mounted; when the cables are exposed to bending and vibration, or the cable may break. As the cable type 0.2SQ cannot be used, a cable type with a large conductor area should be used. The shield cable or the twist cable should be selected according to the instructions of Mitsubishi.

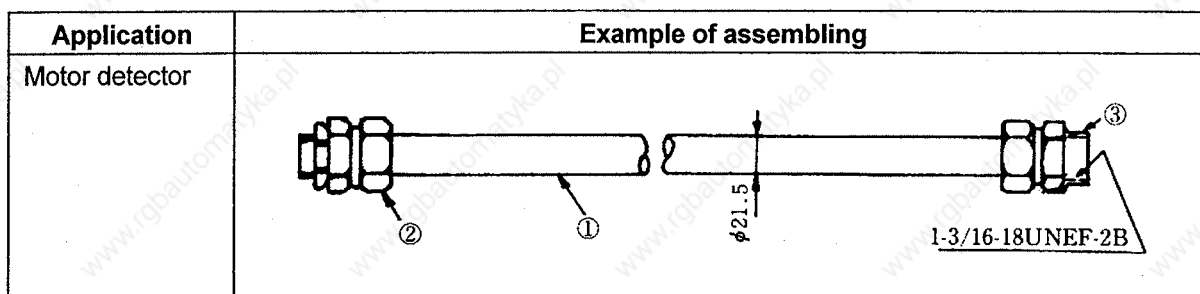

| ① Tube | Connector | | | Manufacturer |
|---|--|--|------------------|---------------------|
| | ② Amplifier | Installation screw | ③ Motor detector | |
| FBA-4 (FePb wire blade sheath) | RBC-104(Straight) RBC-204 (45°) RBC-304 (90°) | G16 G16 G16 | RCC-104-CA2022 | Nippon Flex K/K |
| Preca tube PA-2 #17 (FePb sheath) | BC-17 (Straight) | Conduit thread 15 | PDC20-17 | Sankei S/S |
| High flex PT #17 (FePb sheath) | PSG-104 (Straight) PLG-17 (90°) PS-17 (Straight) | Thread dia. ϕ 26.4 Thread dia. ϕ 26.4 PF 1/2 | PDC20-17 | Daiwa Dengyo K/K |

5. Drive Section Connector and Cable Specifications

5.2.9 Oil proof type AC servomotor cable connectors (Recommendation 1)

When using the motor and cable in an environment where cutting fluids or lubricants may come in contact at all, use the oil-proof specification cable connector (plug) shown below for the motor and encoder.

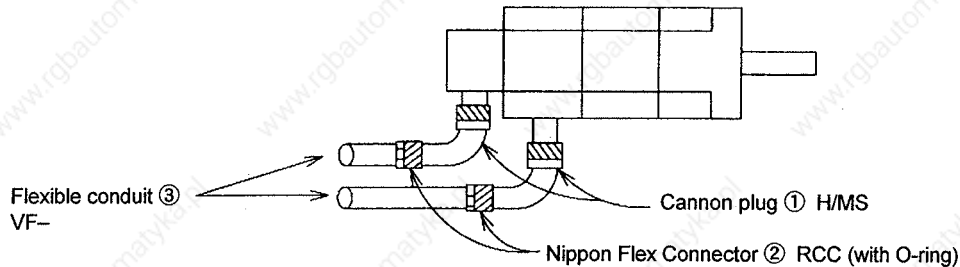

For motor connector

| Servomotor model | | ① Canon plug (Plug unit) | | ② Nippon Flex connector | ③ Flexible conduit | |
|--|------------------------|--|--|--|--------------------|--------------|
| | | 1) Hirose, 2) Japan Aviation Electronics, 3) DDK | | | Nippon Flex | Nippon Flex |
| | | 90° angle type | Straight type | | | |
| HA053C HA13C HA23NC HA33NC | Standard | 1) H/MS3108A18-12S-D | 1) H/MS3106A18-12S-D | RCC-103CA18 (with O-ring) | VF-03 | 10.6 |
| | European standard part | 2) JL04V-8A18-12SE-EB 3) CE05-8A18-12SD-B-BAS | 2) JL04V-6A18-12SE-EB 3) CE05-6A18-12SD-B-BSS | RCC-104CA18 (with O-ring) RCC-106CA18 (with O-ring) | VF-04 VF-06 | 14.0 19.0 |
| HA40NC~HA80NC HA43NC~HA83NC HA50LC~HA150LC HA53LC~HA153LC | Standard | 1) H/MS3108A22-23S-D | 1) H/MS3106A22-23S-D | RCC-104CA2022 (with O-ring) | VF-04 | 14.0 |
| | European standard part | 2) JL04V-8A22-23SE-EB 3) CE05-8A22-23SD-B-BAS | 2) JL04V-6A22-23SE-EB 3) CE05-6A22-23SD-B-BSS | RCC-106CA2022 (with O-ring) RCC-108CA2022 (with O-ring) | VF-06 VF-08 | 19.0 24.4 |
| HA100NC~HA300NC HA103NC~HA203NC HA200LC~HA500LC HA203LC~HA303LC | Standard | 1) H/MS3108A24-10S-D | 1) H/MS3106A24-10S-D | RCC-104CA2428 (with O-ring) | VF-04 | 14.0 |
| | European standard part | 2) JL04V-8A24-10SE-EB 3) CE05-8A24-10SD-B-BAS | 2) JL04V-6A24-10SE-EB 3) CE05-6A24-10SD-B-BSS | RCC-106CA2428 (with O-ring) RCC-108CA2428 (with O-ring) | VF-06 VF-08 | 19.0 24.4 |

For brake cable

| | | | | | |
|----------------------------------|-----------------------|-----------------------|------------------------------|-------|-----|
| HA053CB~33NCB HA100NCB~300NCB | H/MS 3108A 10SL-4S | H/MS 3106A 10SL-4S | RCC-102CA12 (with O-ring) | VF-02 | 8.3 |
|----------------------------------|-----------------------|-----------------------|------------------------------|-------|-----|

For detector cable

| | | | | | |
|--|------------------------|------------------------|--|----------------|--------------|
| HA053/13 motor built-in encoder | H/MS 3108B 20-29S-N | H/MS 3106A 20-29S-N | RCC-104CA2022 (with O-ring) | VF-04 | 14.0 |
| | | | RCC-106CA2022 (with O-ring) | VF-06 | 19.0 |
| OHE25K-□ OHA25K-□ OSE104□ OSA104□ OSE105□ OSA105□ | H/MS 3108B 22-14S-N | H/MS 3106A 22-14S-N | RCC-104CA2022 (with O-ring) | VF-04 | 14.0 |
| | | | RCC-106CA2022 (with O-ring) RCC-108CA2022 (with O-ring) | VF-06 VF-08 | 19.0 24.4 |

5. Drive Section Connector and Cable Specifications

5.2.10 Oil-proof type servomotor connectors (Recommendation 2)

When using the motor and cable in an environment where cutting fluids or lubricants may come in contact at all, use the oil-proof specification connector (plug) shown below for the motor and encoder.

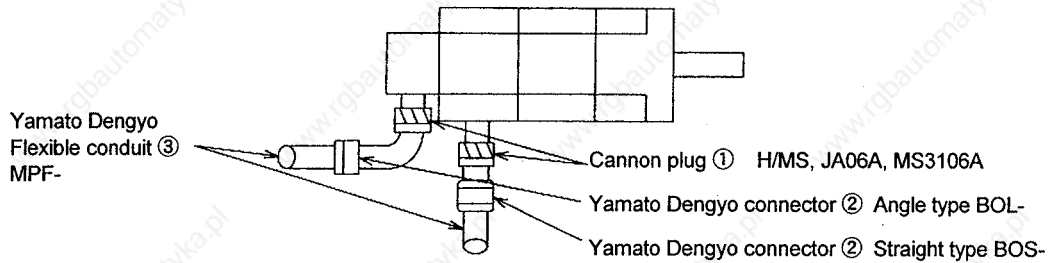

For motor connector

| Servomotor model | ① Cannon plug (Plug unit) | | ② Yamato Dengyo connector | ③ Yamato Dengyo flexible conduit | |
|--|--|---|---------------------------|----------------------------------|-------|
| | 1) Hirose, 2) Japan Aviation Electronics, 3) DDK straight type | | | Model | Model |
| | Standard | European standard part | | | |
| HA053C HA13C HA23NC HA33NC | 1) H/MS3106A18-12S-D (03) 2) JA06A-18-12S-J1 3) MS3106A18-12S (D190) | 2) JL04V-6A18-12SE 3) CE05-6A18-12SD-B | BOS-18-13 BOL-18-13 | MPF-13 | 11.4 |
| | | | BOS-18-15 BOL-18-15 | MPF-15 | 14.2 |
| | | | BOS-18-19 BOL-18-19 | MPF-19 | 17.2 |
| HA40NC~HA80NC HA43NC~HA83NC HA50LC~HA150LC HA53LC~HA153LC | 1) H/MS3106A22-23S-D (03) 2) JA06A-22-23S-J1 3) MS3106A22-23S (D190) | 2) JL04V-6A22-23SE 3) CE05-6A22-23SD-B | BOS-22-15 BOL-22-15 | MPF-15 | 14.2 |
| | | | BOS-22-19 BOL-22-19 | MPF-19 | 17.2 |
| | | | BOS-22-25 BOL-22-25 | MPF-25 | 23.5 |
| HA100NC~HA300NC HA103NC~HA203NC HA200LC~HA500LC HA203LC~HA303LC | 1) H/MS3106A24-10S-D (03) 2) JA06A-24-10S-J1 3) MS3108B24-10S (D190) | 2) JL04V-6A24-10SE 3) CE05-6A24-10SD-B | BOS-24-15 BOL-24-15 | MPF-15 | 14.2 |
| | | | BOS-24-19 BOL-24-19 | MPF-19 | 17.2 |
| | | | BOS-24-25 BOL-24-25 | MPF-25 | 23.5 |

For brake cable

| | | | | | |
|----------------------------------|---|---|----------------------|-------|-----|
| HA053CB~33NCB HA100NCB~300NCB | H/MS 3106A10SL-4S (03) JA06A-10SL-4S-JI MS3106A10SL-4S (D190) | (Hirose) (Japan Aviation Electronics) (DDK) | BOS-10-9 BOL-10-9 | MPF-9 | 8.2 |
|----------------------------------|---|---|----------------------|-------|-----|

For detector cable

| | | | | | |
|--|-------------------------|------------------------------|------------------------|--------|------|
| HA053/13 motor built-in encoder | H/MS 3106A20-29S-N (03) | (Hirose) | BOS-20-15 BOL-20-15 | MPF-15 | 14.2 |
| | JA06A-20-29S-JI | (Japan Aviation Electronics) | BOS-20-19 BOL-20-19 | MPF-19 | 17.2 |
| | MS3106A20-29S (D190) | (DDK) | | | |
| OHE25K-□ OHA25K-□ OSE104□ OSA104□ OSE105□ OSA105□ | H/MS 3106A22-14S-N (03) | (Hirose) | BOS-22-15 BOL-22-15 | MPF-15 | 14.2 |
| | JA06A-22-14S-JI | (Japan Aviation Electronics) | BOS-22-19 BOL-22-19 | MPF-19 | 17.2 |
| | MS3106A22-14S (D190) | (DDK) | BOS-22-25 BOL-22-25 | MPF-25 | 23.5 |
| | | | | | |

5. Drive Section Connector and Cable Specifications

5.2.11 Cable clamp

Mount the grounding plate near the servo amplifier, peel the cable sheath, and press the peeled shield cable to the grounding plate using the cable clamp. If the cable is thin, clamp several cables.

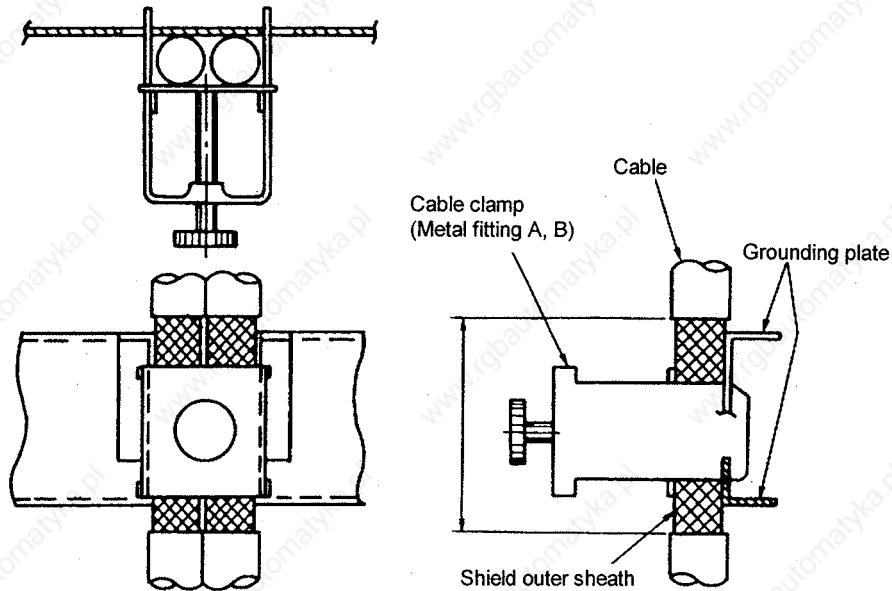

Clamp section drawing

The earth plate D and cable clamps A and B can be supplied by Mitsubishi.

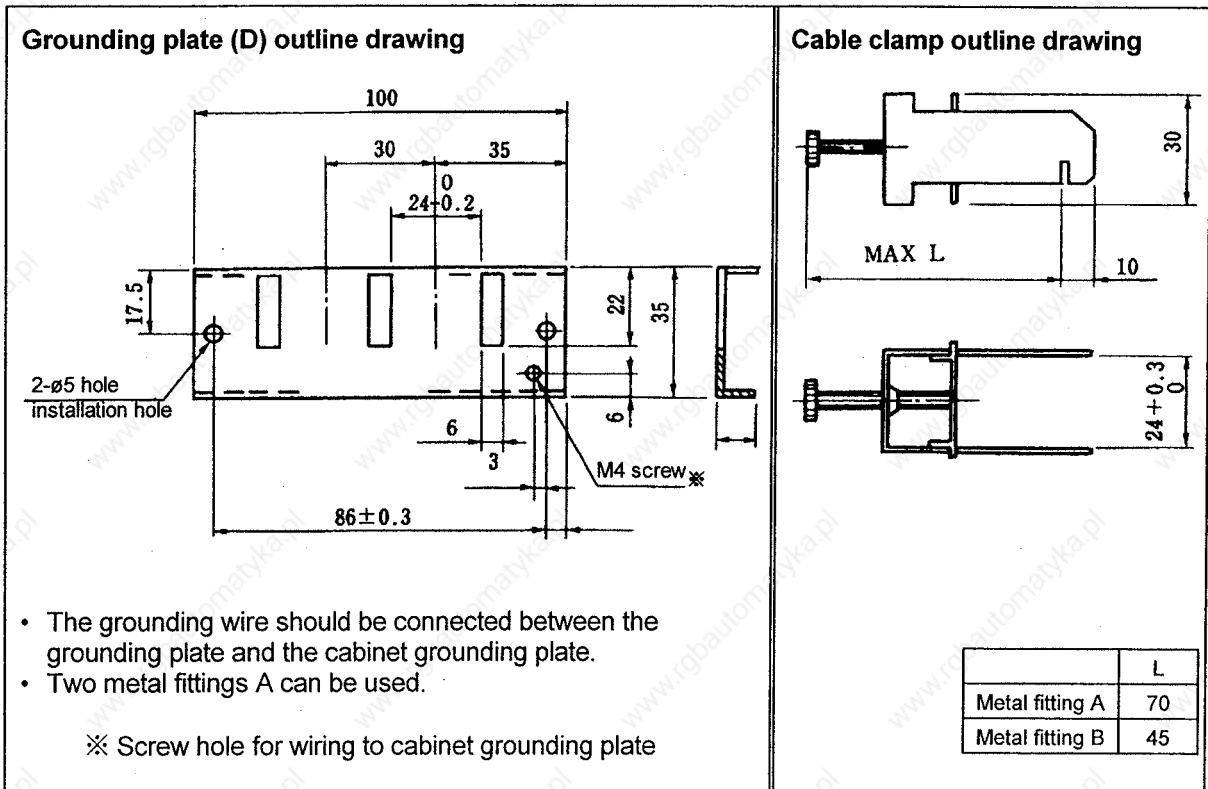

5. Drive Section Connector and Cable Specifications

5.2.12 Spindle control circuit cable list

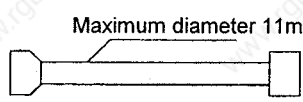
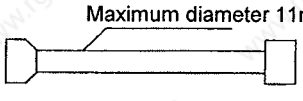
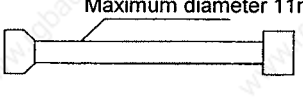
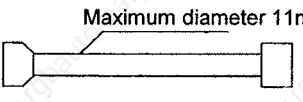
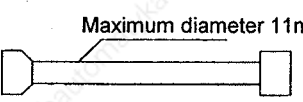
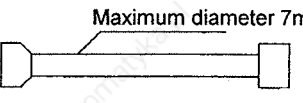
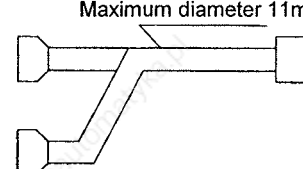
| No. | Application | Drive unit side connection connector | Cable name | Connected device | Arranged by | Applicable cable finished state | Connected device | Arranged by |
|-----|--|--------------------------------------|--------------|---------------------------------------|-------------------|--|---|-------------------------------------|
| | | | | Parts name | | | Parts name | |
| | | | | Maker | | | | |
| (1) | Motor temperature switch signal Motor speed detection signal | CN5 | CNP5 cable | Spindle drive unit | Semi ordered part | Twisted pair batch shield cable 0.2SQ  Maximum diameter 11mm | Motor (connector) Motor (lead wire terminal) | Enclosed with motor |
| | | | | (Shell) 10320-52F0-008 | | | (Connector) AMP-350720-1 (Pin) AMP-350689-1 | |
| | | | | (Plug) 10120-3000VE Sumitomo 3M | | | Japan Amplifier | |
| (2) | Orientation detection signal Magnesensor | CN6 | CNP6M cable | Spindle drive unit | Semi ordered part | Twisted pair batch shield cable 0.2SQ  Maximum diameter 11mm | Magnesensor amplifier | Enclosed with magnesensor amplifier |
| | | | | (Shell) 10320-52F0-008 | | | TRC116-12A0-7F10.5 | |
| | | | | (Plug) 10120-3000VE Sumitomo 3M | | | Tajimi Musen | |
| (3) | Orientation detection signal Encoder | CN6 | CNP6A cable | Spindle drive unit | Semi ordered part | Twisted pair batch shield cable 0.2SQ  Maximum diameter 11mm | Encoder (RFH-1024-) | Enclosed with encoder |
| | | | | (Shell) 10320-52F0-008 | | | MS3106A20-29S | |
| | | | | (Plug) 10120-3000VE Sumitomo 3M | | | DDK | |
| (4) | C-axis detection signal C-axis encoder (OSE90K + 1024) | CN7 | CNP7A cable | Spindle drive unit | Semi ordered part | Twisted pair batch shield cable 0.2SQ  Maximum diameter 11mm | Encoder (OSE90K+1024) | Enclosed with encoder |
| | | | | (Shell) 10320-52F0-008 | | | MS3106A20-29S | |
| | | | | (Plug) 10120-3000VE Sumitomo 3M | | | DDK | |
| (5) | C-axis detection signal C-axis built-in encoder (MBE90K) | CN7 | CNP7B cable | Spindle drive unit | Semi ordered part | Twisted pair batch shield cable 0.2SQ  Maximum diameter 11mm | Encoder (MBE90K) | Enclosed with encoder |
| | | | | (Shell) 10320-52F0-008 | | | (Housing) 69176-020 (Pin) 48235-000 | |
| | | | | (Plug) 10120-3000VE Sumitomo 3M | | | DuPont | |
| (6) | C-axis detection signal C-axis built-in encoder (MHE90K) | CN7 | CNP7H cable | Spindle drive unit | Ordered part | Twisted pair batch shield cable 0.2SQ  Maximum diameter 7mm | Encoder (MHE90K) | Enclosed with encoder |
| | | | | (Shell) 10320-52F0-008 | | | (Housing) JAC-15P (Pin) J-SP1140 | |
| | | | | (Plug) 10120-3000VE Sumitomo 3M | | | Japan Solderless | |
| (7) | C-axis encoder C-axis detection signal + orientation detection signal (OSE90K + 1024) | CN6 + CN7 | CNP67A cable | Spindle drive unit | Semi ordered part | Twisted pair batch shield cable 0.2SQ  Maximum diameter 11mm | Encoder (OSE90K+1024) | Enclosed with encoder |
| | | | | (Shell) 10320-52F0-008 x2 | | | MS3106A20-29S | |
| | | | | (Plug) 10120-3000VE x2 Sumitomo 3M | | | DDK | |

5. Drive Section Connector and Cable Specifications

- (Note 1)** The connector shell on the spindle drive unit is the 3M "10320-52F0-008" but, this is a shell with a one-touch locking mechanism that does not require screw locking. When ordering the cables from Mitsubishi, the shell "10320-52F0-008" with this one-touch lock mechanism will be used. However, if the cable is to be manufactured by the user, the shell "10320-52A0-008" (3M) with the screw lock mechanism can be used instead of the above shell.
- (Note 2)** Each cable length must be 30m or less. The cable for the C-axis built-in encoder MHE90K must be 10m or less.

5. Drive Section Connector and Cable Specifications

● (1) CNP5 cable ●

| Part No. | Part name | Abbr. | Model | Qty/type | |
|----------|---------------------|-------|-------------------------|----------|--------|
| | | | | E-type | 2-type |
| 000 | | | | | |
| 101 | Connector (shell) | CON | 10320-52F0-008 | 1 | 1 |
| 102 | Connector (plug) | CON | 10120-3000VE | 1 | 1 |
| 103 | | | | | |
| 104 | Cable | SEN | F-DPEVSB TS-91026 (DDK) | 1 | 1 |
| 105 | Connector (housing) | CON | 350720-1 | 1 | 1 |
| 106 | Connector (pin) | CON | 350689-1 | | 8 |

Cable name

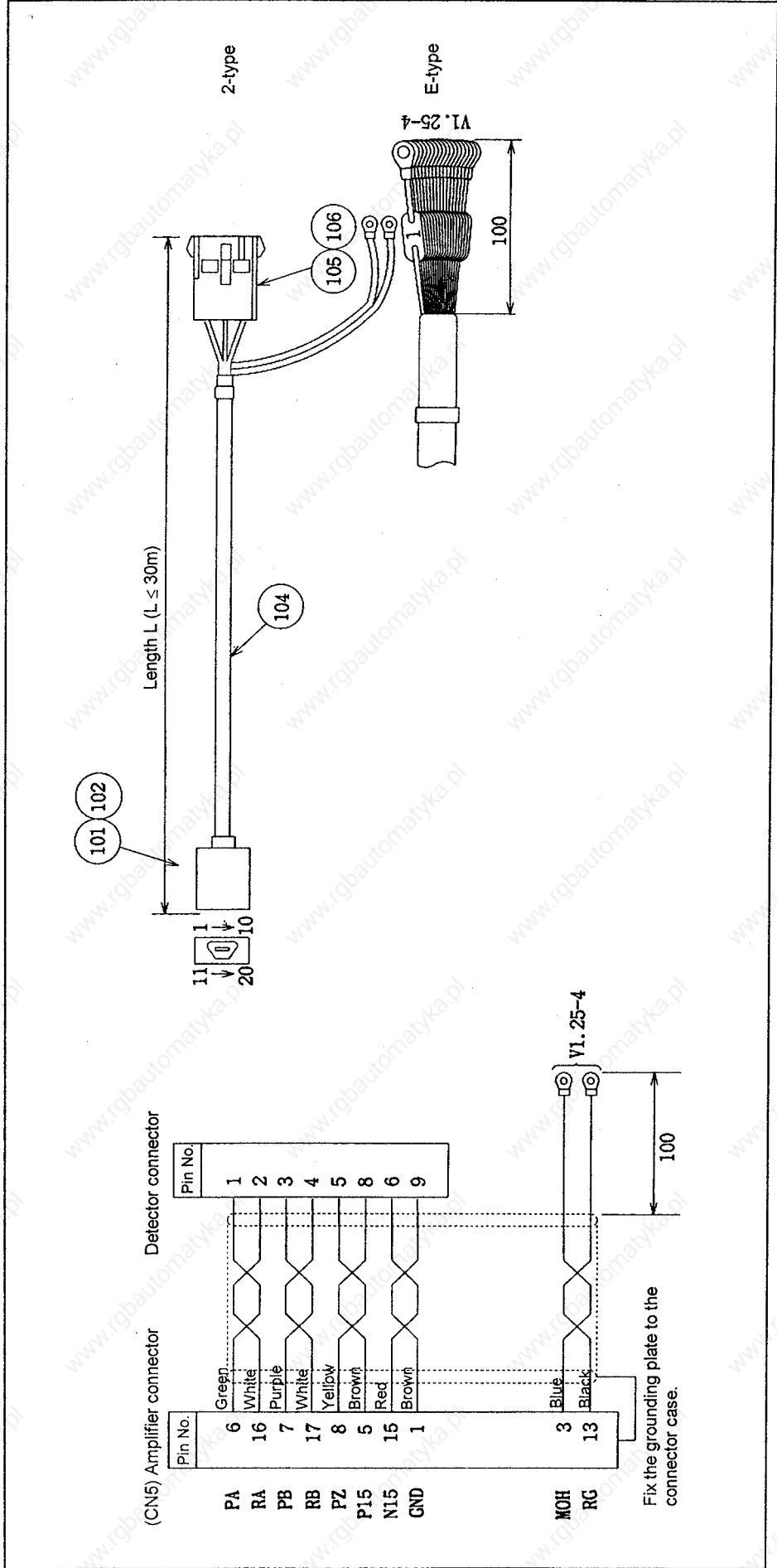
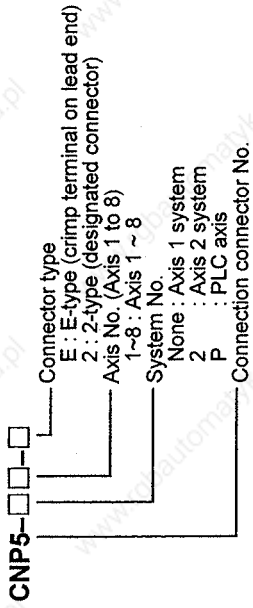

5. Drive Section Connector and Cable Specifications

● (3) CNP6A cable ●

| Part No. | Part name | Abbr. | Model | Qty/type | | |
|----------|-----------------------------|-------|-------------------------|----------|--------|--------|
| | | | | E-type | 2-type | 3-type |
| 000 | | | | | | |
| 101 | Connector (shell) | CON | 10320-52F0-008 | 1 | 1 | 1 |
| 102 | Connector (plug) | CON | 10120-3000VE | 1 | 1 | 1 |
| 103 | | | | | | |
| 104 | Cable | SEN | F-DPEVSB TS-91026 (DDK) | 1 | 1 | 1 |
| 105 | Cannon connector (angle) | CON | MS3108B20-29S | | | 1 |
| 106 | Connector clamp | CON | MS3057-12A | | 1 | 1 |
| 107 | | | | | | |
| 108 | Cannon connector (straight) | CON | MS3106B20-29S | | | 1 |

Cable name

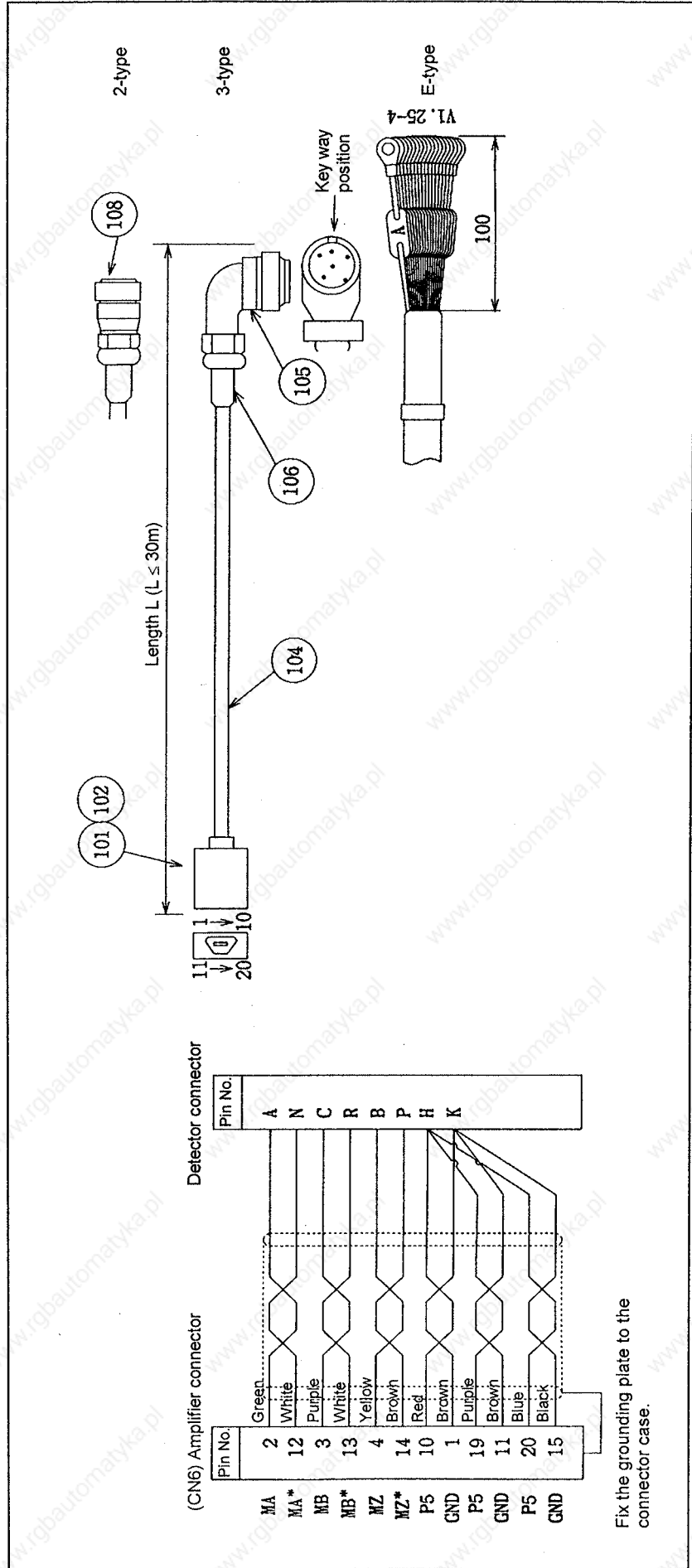
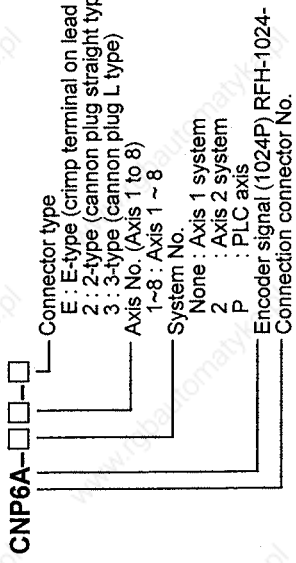

Fix the grounding plate to the connector case.

5. Drive Section Connector and Cable Specifications

● (4) CNP7A cable ●

| Part No. | Part name | Abbr. | Model | Qty/type | | |
|----------|-----------------------------|-------|-------------------------|----------|--------|--------|
| | | | | E-type | 2-type | 3-type |
| 000 | | | | | | |
| 101 | Connector (shell) | CON | 10320-52F0-008 | 1 | 1 | 1 |
| 102 | Connector (plug) | CON | 10120-3000VE | 1 | 1 | 1 |
| 103 | | | | | | |
| 104 | Cable | SEN | F-DPEVSB TS-91026 (DDK) | 1 | 1 | 1 |
| 105 | Cannon connector (angle) | CON | MS3108B20-29S | | | 1 |
| 106 | Connector clamp | CON | MS3057-12A | | 1 | 1 |
| 107 | | | | | | |
| 108 | Cannon connector (straight) | CON | MS3106B20-29S | | | 1 |

Cable name

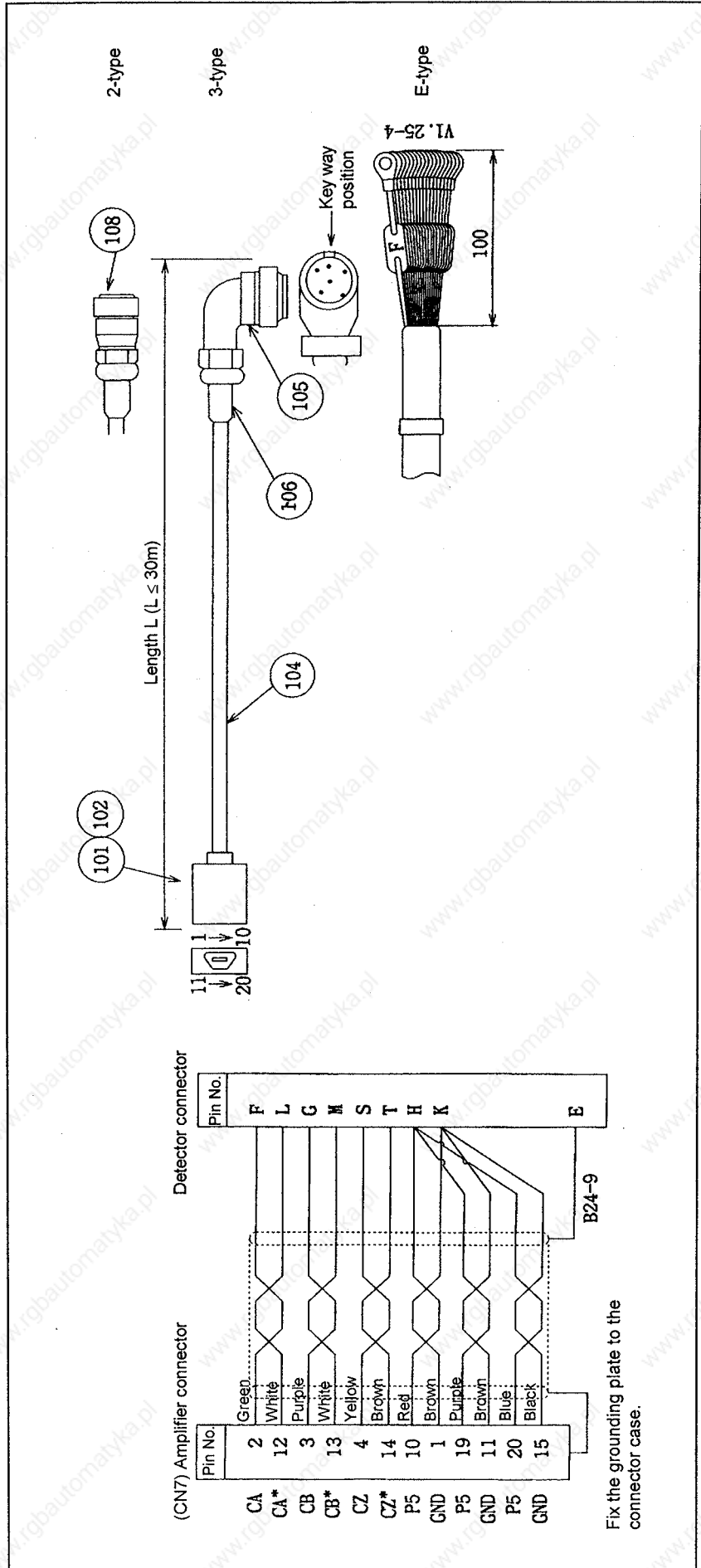
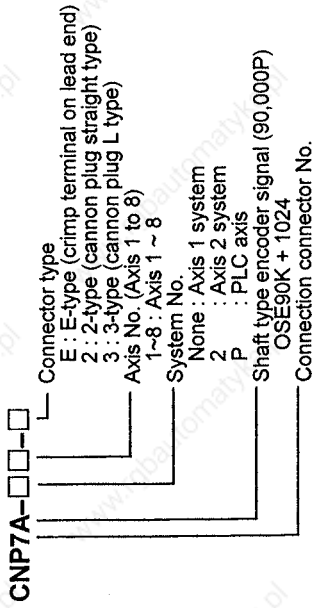

5. Drive Section Connector and Cable Specifications

● (6) CNP7H cable ●

| Part No. | Part name | Abbr. | Model | Qty/type | |
|----------|---------------------|-------|----------------|----------|--------|
| 000 | | | | E-type | 2-type |
| 101 | Connector (shell) | CON | 10320-52F0-008 | 1 | 1 |
| 102 | Connector (plug) | CON | 10120-3000VE | 1 | 1 |
| 103 | | | | | |
| 104 | Cable | SEN | | 1 | 1 |
| 105 | Connector (housing) | CON | JAC-15P | 1 | |
| 106 | Connector (pin) | CON | J-SP1140 | | 7 |
| 107 | | | | | |
| 108 | | | | | |

Cable name

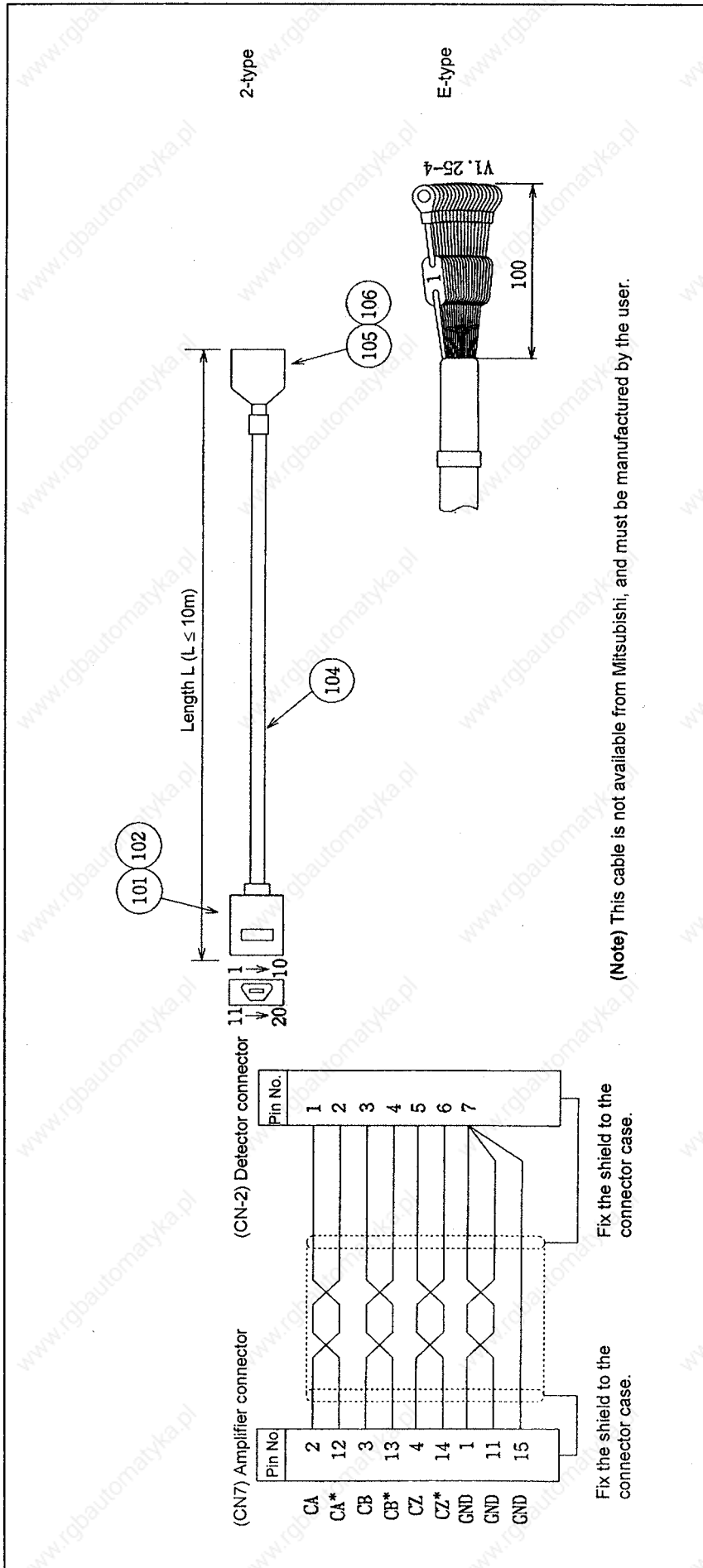
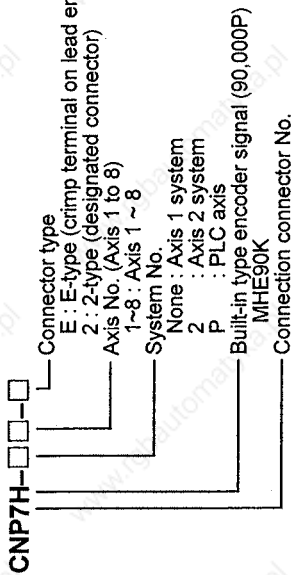

(Note) This cable is not available from Mitsubishi, and must be manufactured by the user.

Fix the shield to the connector case.

Fix the shield to the connector case.

5. Drive Section Connector and Cable Specifications

● (8) CNP71A cable ●

| Part No. | Part name | Abbr. | Model | Qty/type | | |
|----------|-----------------------------|-------|-------------------------|----------|--------|--------|
| | | | | E-type | 2-type | 3-type |
| 000 | | | | | | |
| 101 | Connector (shell) | CON | 10320-52FO-008 | 1 | 1 | 1 |
| 102 | Connector (plug) | CON | 10120-3000VE | 1 | 1 | 1 |
| 103 | Cannon connector (straight) | CON | MS3106B20-29S | | 1 | |
| 104 | Cable | SEN | F-DPEVSB TS-91026 (DDK) | 2 | 2 | |
| 105 | Cannon connector (angle) | CON | MS3108B20-29S | | | 1 |
| 106 | Connector clamp | CON | MS3057-12A | | 1 | 1 |
| 107 | Connector | CON | CDA-15P | 1 | 1 | 1 |
| 108 | Contact | CON | CD-PC-111 | 6 | 6 | 6 |
| 109 | Case | CON | HDA-CTF | 1 | 1 | 1 |

Cable name

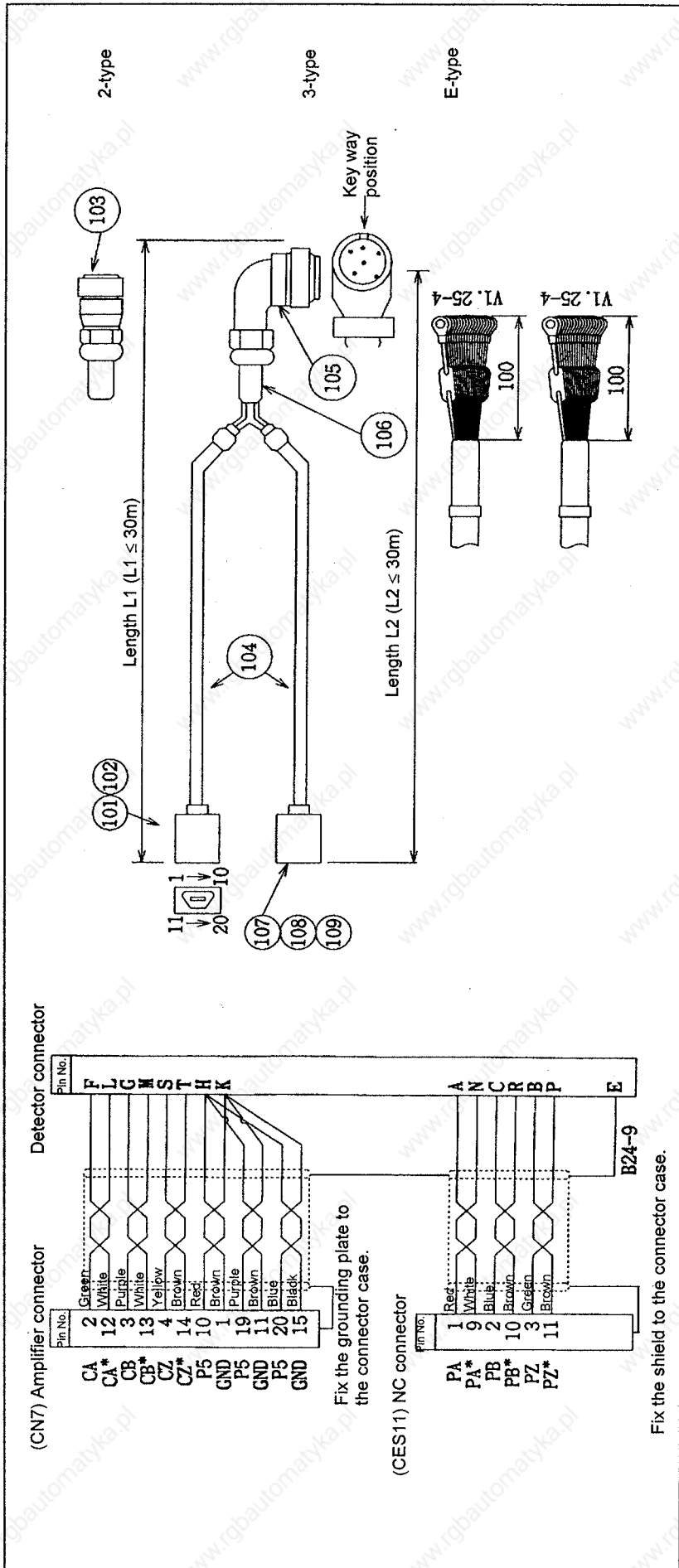
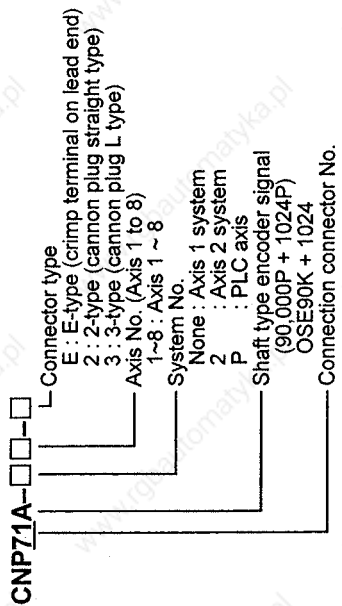

5. Drive Section Connector and Cable Specifications

● (9) CNP71B cable ●

| Part No. | Part name | Abbr. | Model | Qty/type | |
|----------|---------------------|-------|-------------------------|----------|--------|
| | | | | E-type | 2-type |
| 000 | | | | | |
| 101 | Connector (shell) | CON | 10320-52F0-008 | 1 | 1 |
| 102 | Connector (plug) | CON | 10120-3000VE | 1 | 1 |
| 103 | | | | | |
| 104 | Cable | SEN | F-DPEVSB TS-91026 (DDK) | 2 | 2 |
| 105 | Connector (housing) | CON | 69176-020 | | 1 |
| 106 | Connector (pin) | CON | 48235-000 | | 19 |
| 107 | Connector | CON | CDA-15P | 1 | 1 |
| 108 | Contact | CON | CD-PC-111 | 6 | 6 |
| 109 | Case | CON | HDA-CTF | 1 | 1 |

Cable name

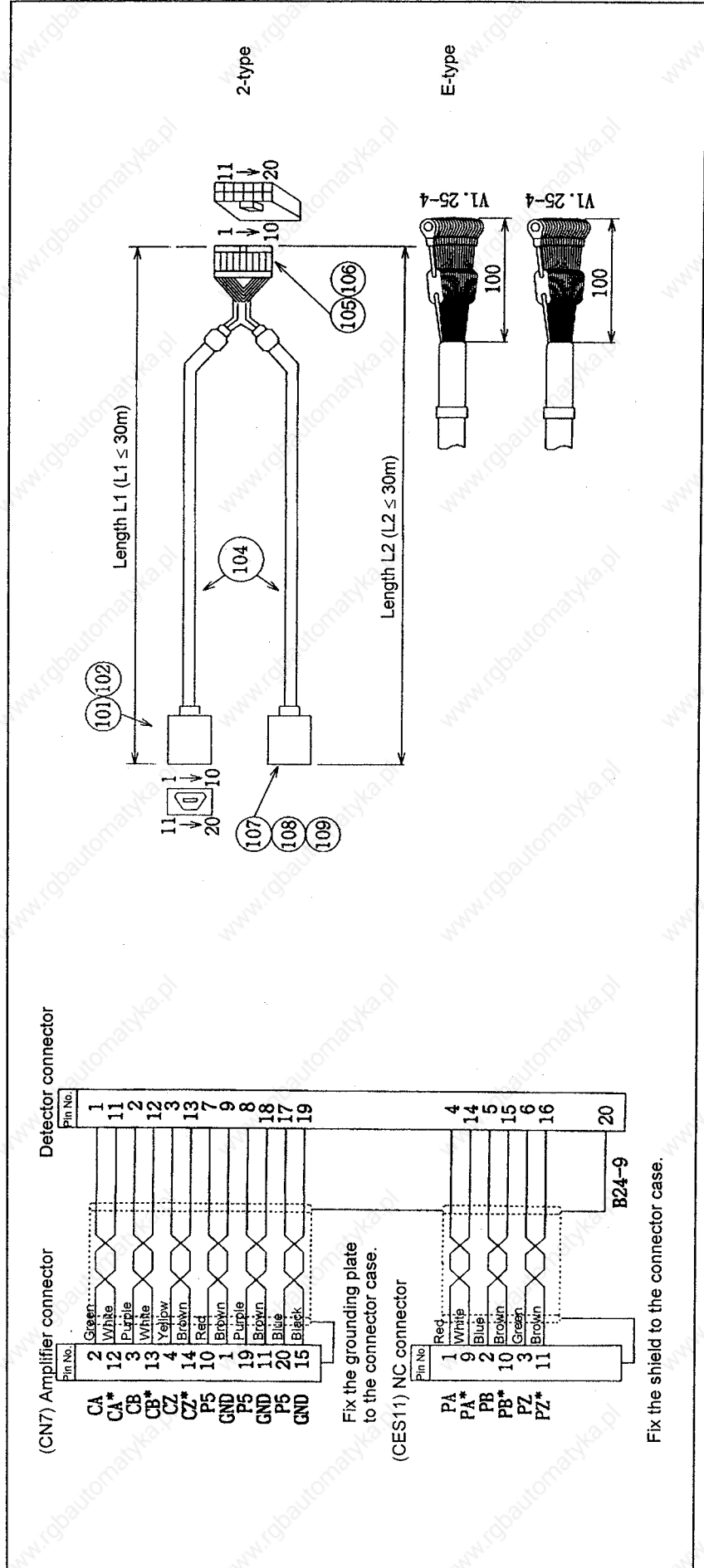
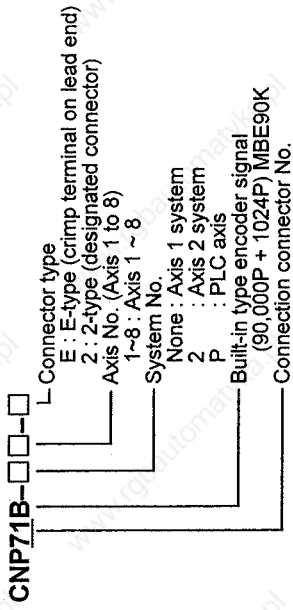

5. Drive Section Connector and Cable Specifications

● (10) CNP71H cable ●

| Part No. | Part name | Abbr. | Model | Qty/type | |
|----------|---------------------|-------|-------------------------|----------|--------|
| 000 | | | | E-type | 2-type |
| 101 | Connector (shell) | CON | 10320-52F0-008 | 1 | 1 |
| 102 | Connector (plug) | CON | 10120-3000VE | 1 | 1 |
| 103 | | | | | |
| 104 | Cable | SEN | F-DPEVSB TS-91026 (DDK) | 2 | 2 |
| 105 | Connector (housing) | CON | JAC-15P | 2 | 2 |
| 106 | Connector (pin) | CON | J-SP1140 | 13 | 13 |
| 107 | Connector | CON | CDA-15P | 1 | 1 |
| 108 | Contact | CON | CD-PC-111 | 6 | 6 |
| 109 | Case | CON | HDA-CTF | 1 | 1 |

Cable name

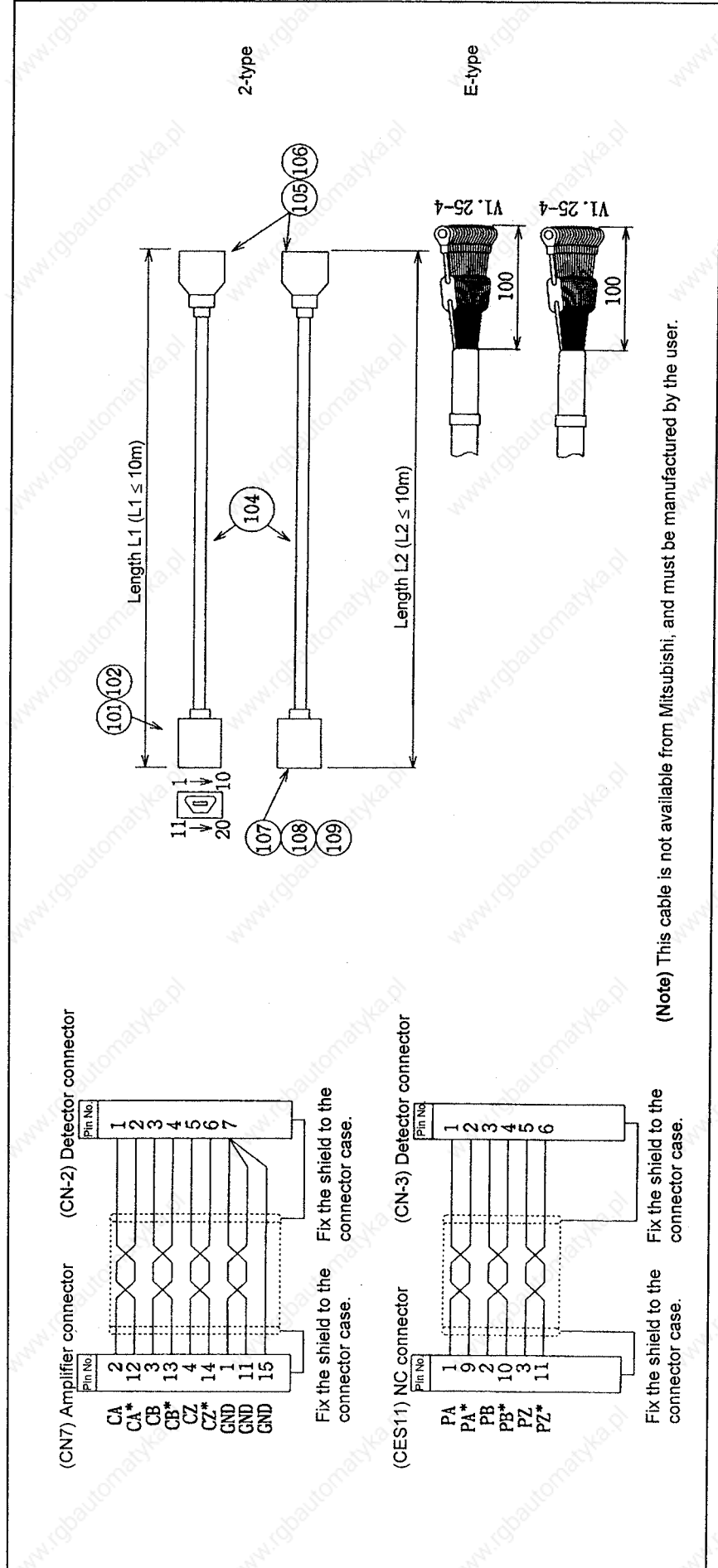
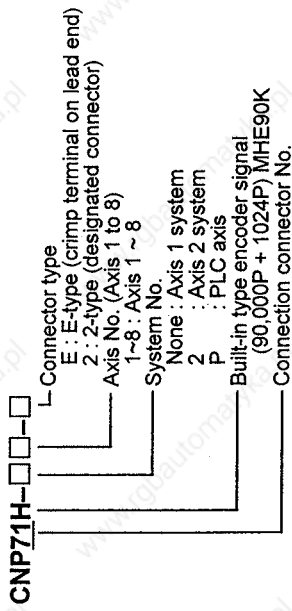

(Note) This cable is not available from Mitsubishi, and must be manufactured by the user.

5. Drive Section Connector and Cable Specifications

● (12) CNP8H cable ●

| Part No. | Part name | Abbr. | Model | Qty/type |
|----------|-------------------|-------|-------------------------|----------|
| 000 | | | | |
| 101 | Connector (shell) | CON | 10320-52F0-008 | 1 |
| 102 | Connector (plug) | CON | 10120-3000VE | 1 |
| 103 | | | | |
| 104 | Cable | SEN | F-DPEVSB TS-91026 (DDK) | 1 |
| 105 | Connector | CON | CDA-15P | 1 |
| 106 | Contact | CON | CD-PC-111 | 14 |
| 107 | Case | CON | HDA-CTF | 1 |

(Note) When using the 2-axis spindle, the required quantity of part Nos. (101) to (104) on the left will be two.

Cable name
CNP8

_____ Connection connector No.

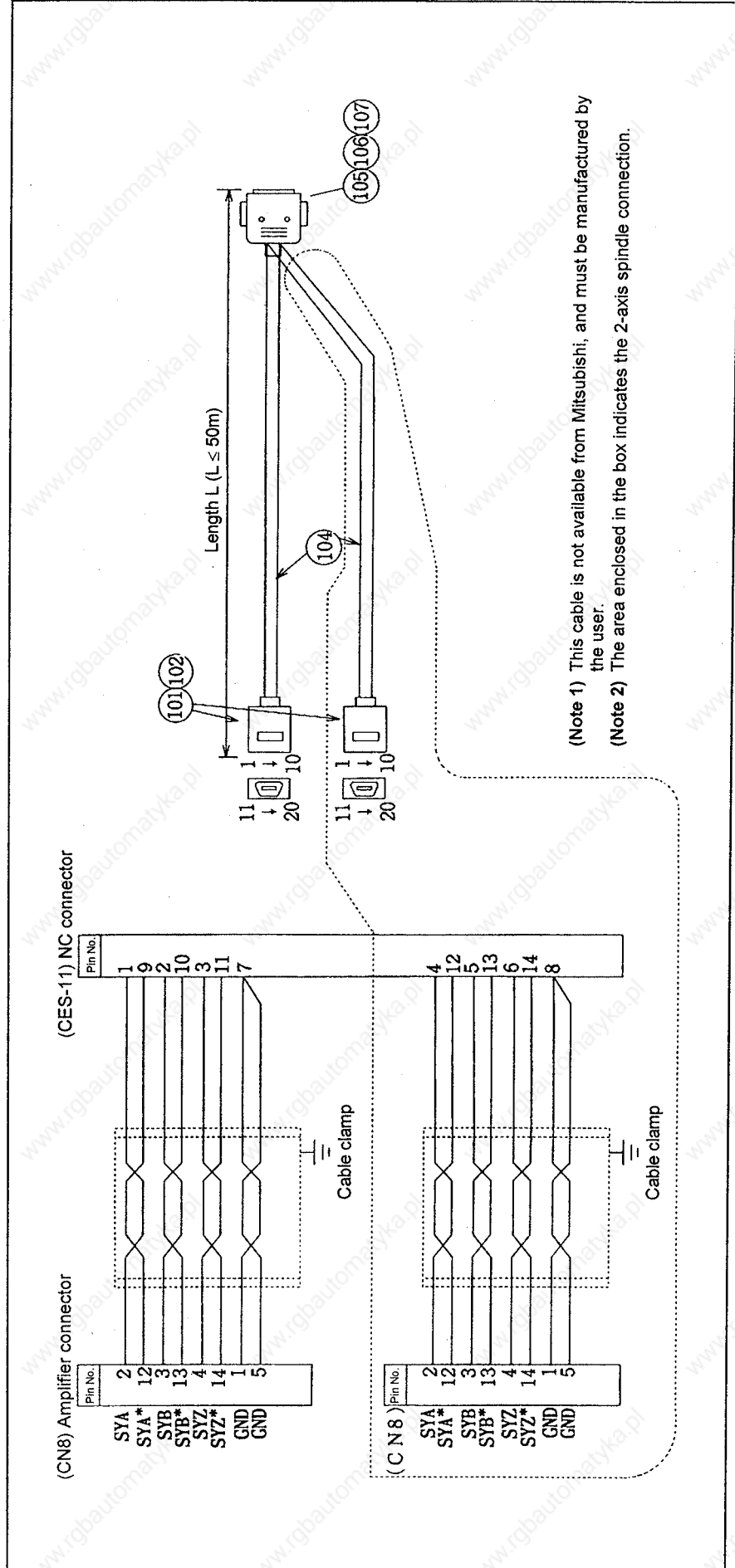

5. Drive Section Connector and Cable Specifications

5.2.13 Cable assembly procedure (Excluding SH21 cable)

(1) Non-shield shell assembly procedure I

One-touch locking type

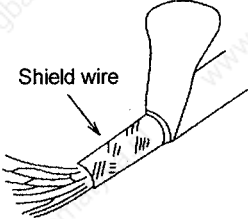
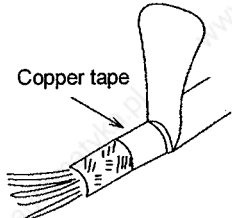
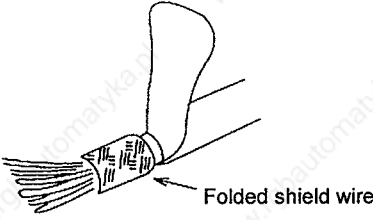
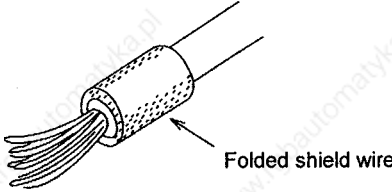
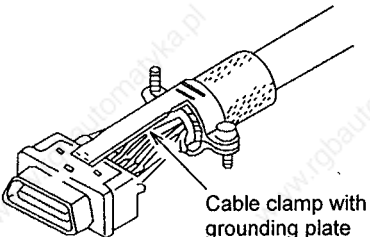
| | |
|--|--|
| <p>①</p>  | <p>Peel the outer sheath so that the shield wires are exposed.</p> |
| <p>②</p>  | <p>Wrap copper tape or vinyl tape around part of the shield wire section.</p> |
| <p>③</p>  | <p>Fold the shield wire over the wrapped copper tape or vinyl tape.</p> |
| <p>④</p>  | <p>Cut off any excess sheath.</p> |
| <p>⑤</p>  | <p>After connecting the connector and cable, mount the cable clamp approx. 1 to 2mm from the cable end, and tighten the screw until the cable clamp screw section face contacts closely.</p> <p>Note. Adjust the No. of copper tape windings in step ② so that the shield wire and clamp contact without looseness and so that the clamp's screw section face is closely contacted.</p> |

5. Drive Section Connector and Cable Specifications

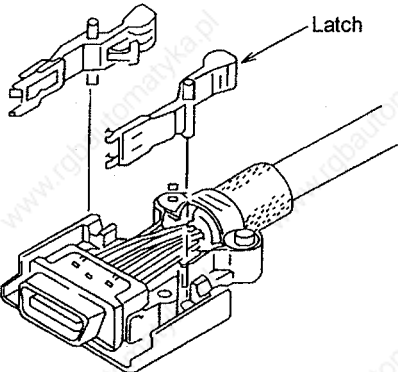
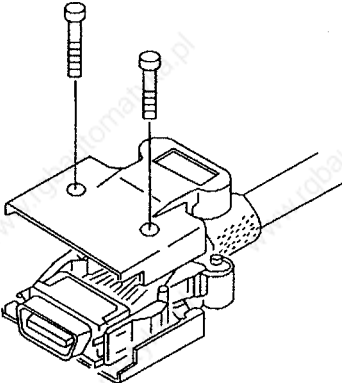
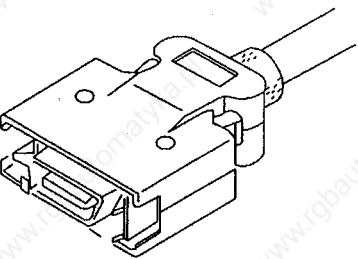
| | |
|--|--|
| <p>⑥</p>  | <p>Store a connector and latch at the respective positions on one end of the shell. (The shell is reversible, so store on either side.)</p> <p>Note. Make sure that the cable does not rise up or exceed the shell's inner wall to prevent breakage of the cable.</p> |
| <p>⑦</p>  | <p>Set the other shell and tighten with a screw.</p> <p>Note. Recommended screw tightening torque: 3kgf·cm</p> |
| <p>⑧</p>  | <p>Completion</p> <p>Confirmation items :</p> <ul style="list-style-type: none">• There is no clearance on the shell engaging face.• The latch can be correctly opened and closed when moved with a finger. |

5. Drive Section Connector and Cable Specifications

(2) Non-shield shell assembly procedure II

Jack screw (screw lock) type

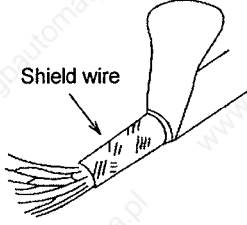
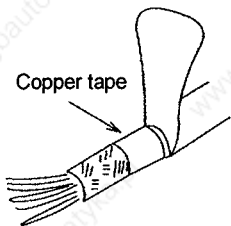
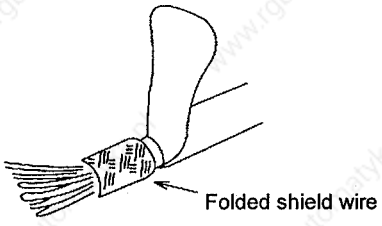
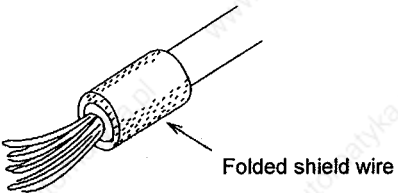
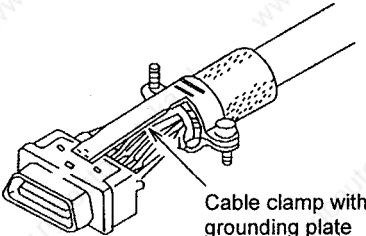
| | |
|--|--|
| <p>①</p>  | <p>Peel the outer sheath so that the shield wires are exposed.</p> |
| <p>②</p>  | <p>Wrap copper tape or vinyl tape around part of the shield wire section.</p> |
| <p>③</p>  | <p>Fold the shield wire over the wrapped copper tape or vinyl tape.</p> |
| <p>④</p>  | <p>Cut off any excess sheath.</p> |
| <p>⑤</p>  | <p>After connecting the connector and cable, mount the cable clamp approx. 1 to 2mm from the cable end, and tighten the screw until the cable clamp screw section face contacts closely.</p> <p>Note. Adjust the No. of copper tape windings in step ② so that the shield wire and clamp contact without looseness and so that the clamp's screw section face is closely contacted.</p> |

5. Drive Section Connector and Cable Specifications

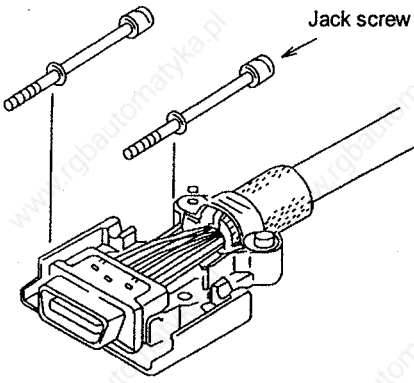
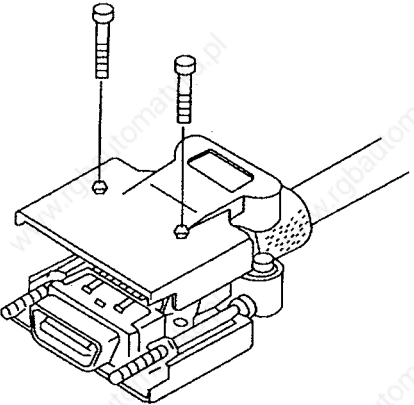
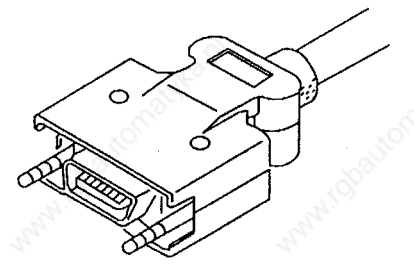
| | |
|--|---|
| <p>⑥</p>  | <p>Store a connector and jack screw at the respective positions on one end of the shell. (The shell is reversible, so store on either side.)</p> <p>Note. Make sure that the cable does not rise up or exceed the shell's inner wall to prevent breakage of the cable.</p> |
| <p>⑦</p>  | <p>Set the other shell and tighten with a screw.</p> <p>Note. Recommended screw tightening torque: 3kgf·cm</p> |
| <p>⑧</p>  | <p>Completion</p> <p>Confirmation items :</p> <ul style="list-style-type: none">• There is no clearance on the shell engaging face. |

6. Outline Drawing

6.2 Power supply unit

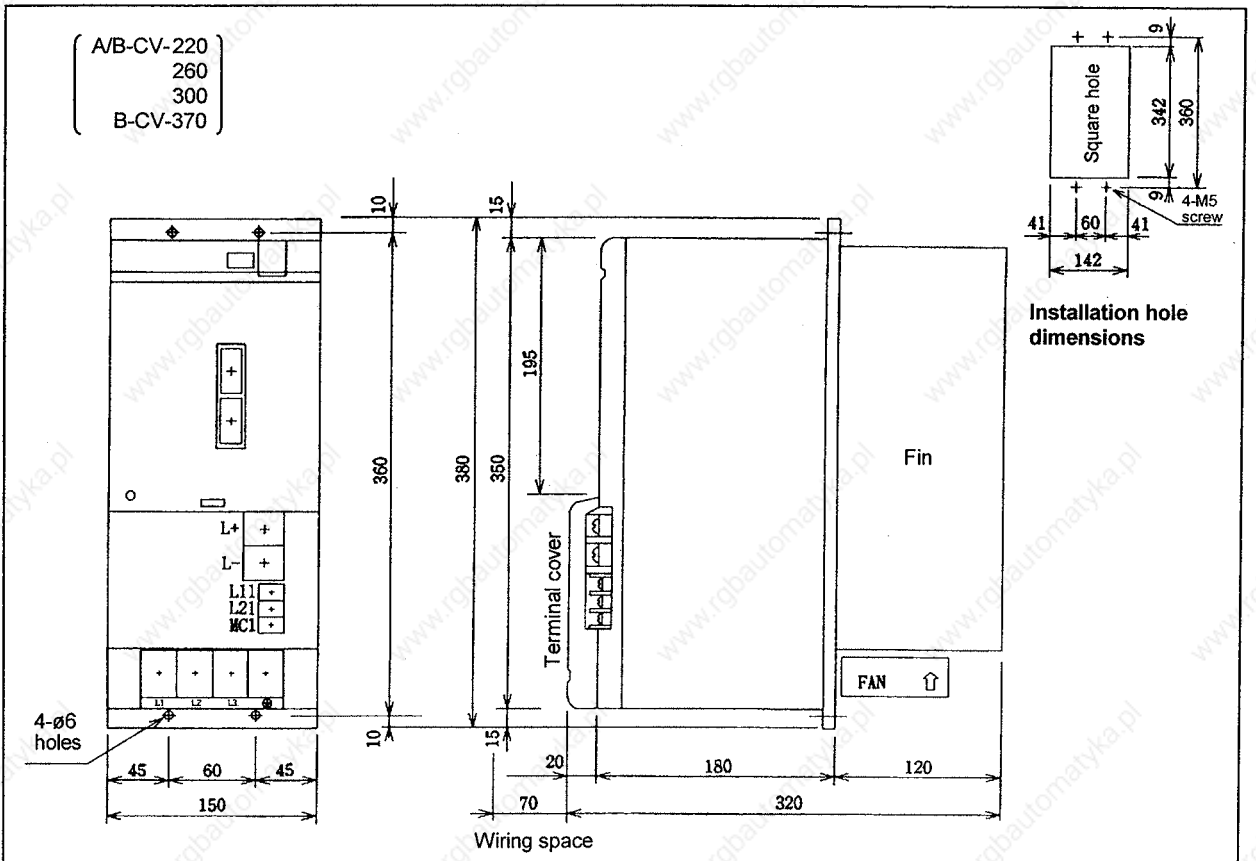
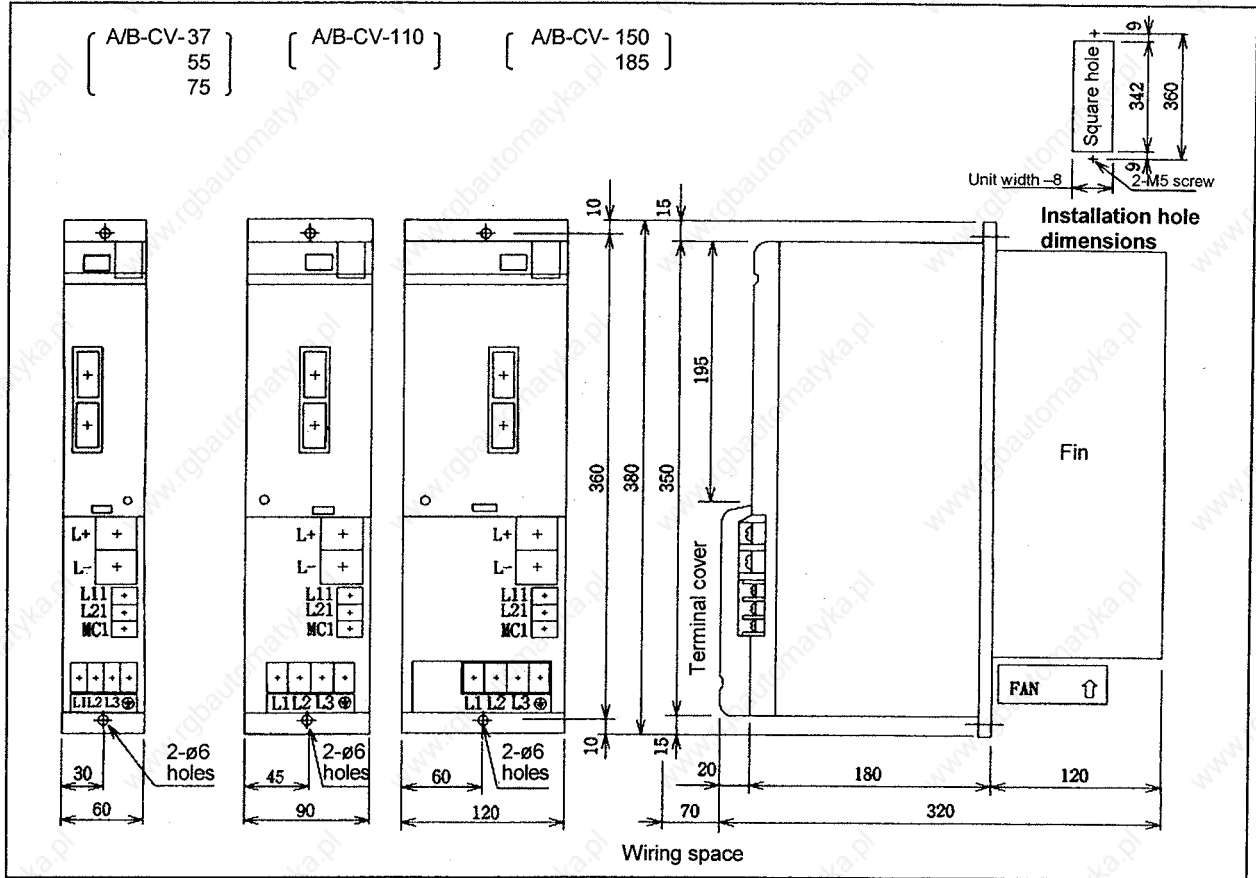

6. Outline Drawing

6.3 1-axis servo drive unit

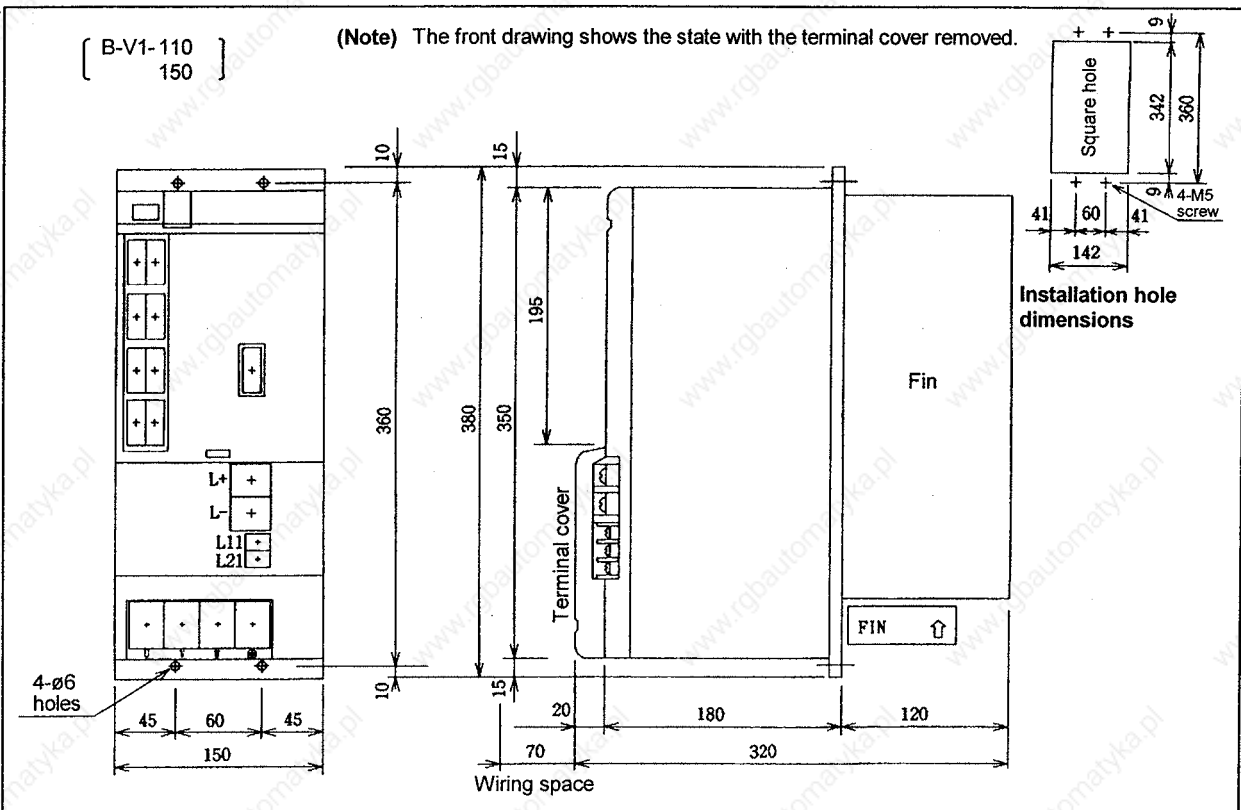
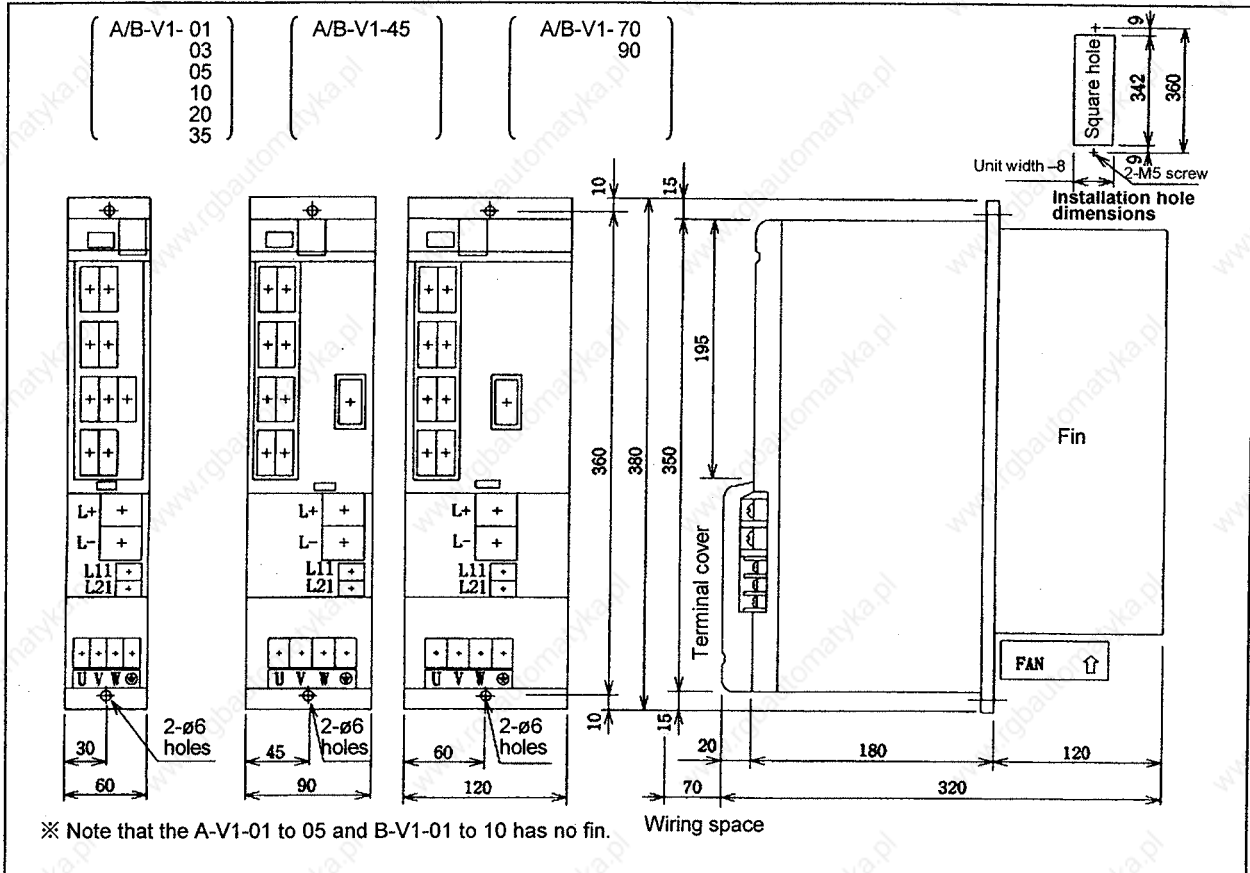

6. Outline Drawing

6.4 2-axis servo drive unit

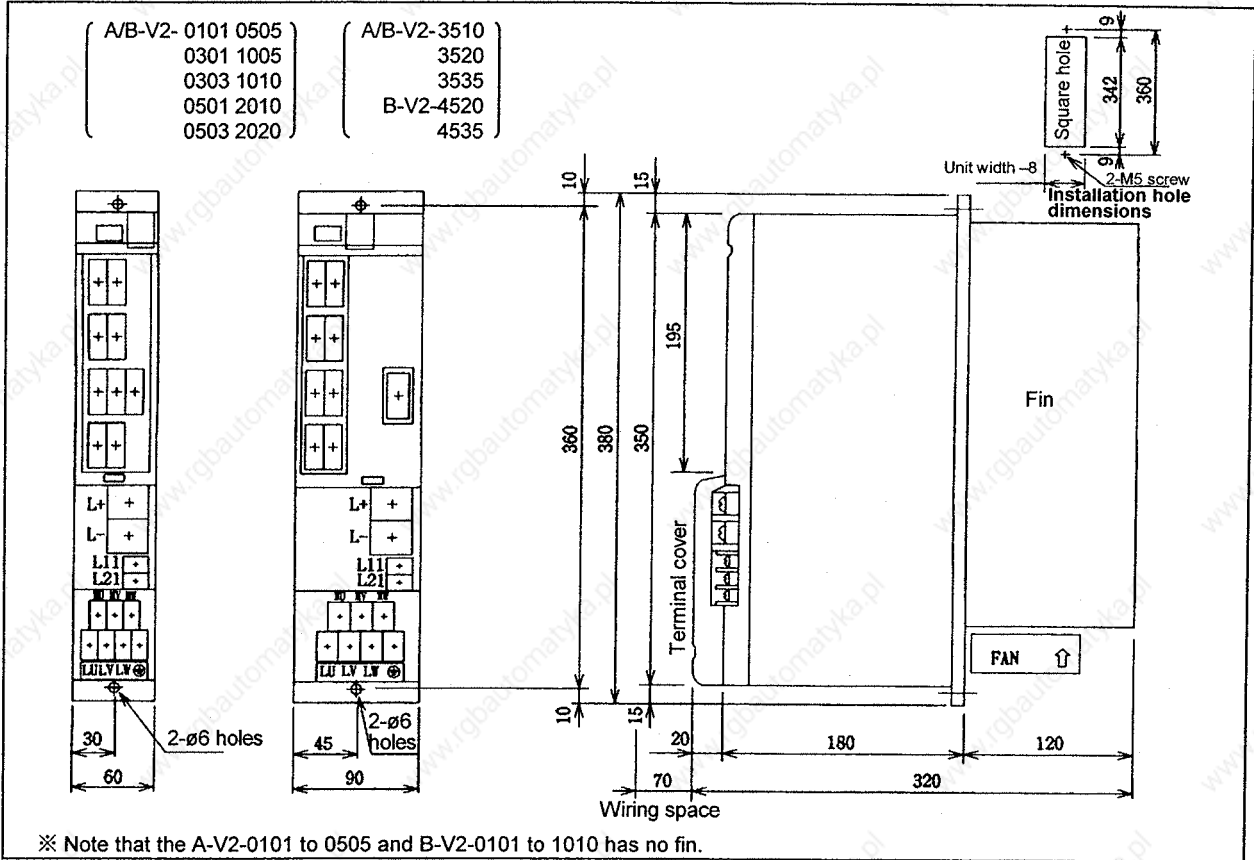

6.5 Spindle drive unit

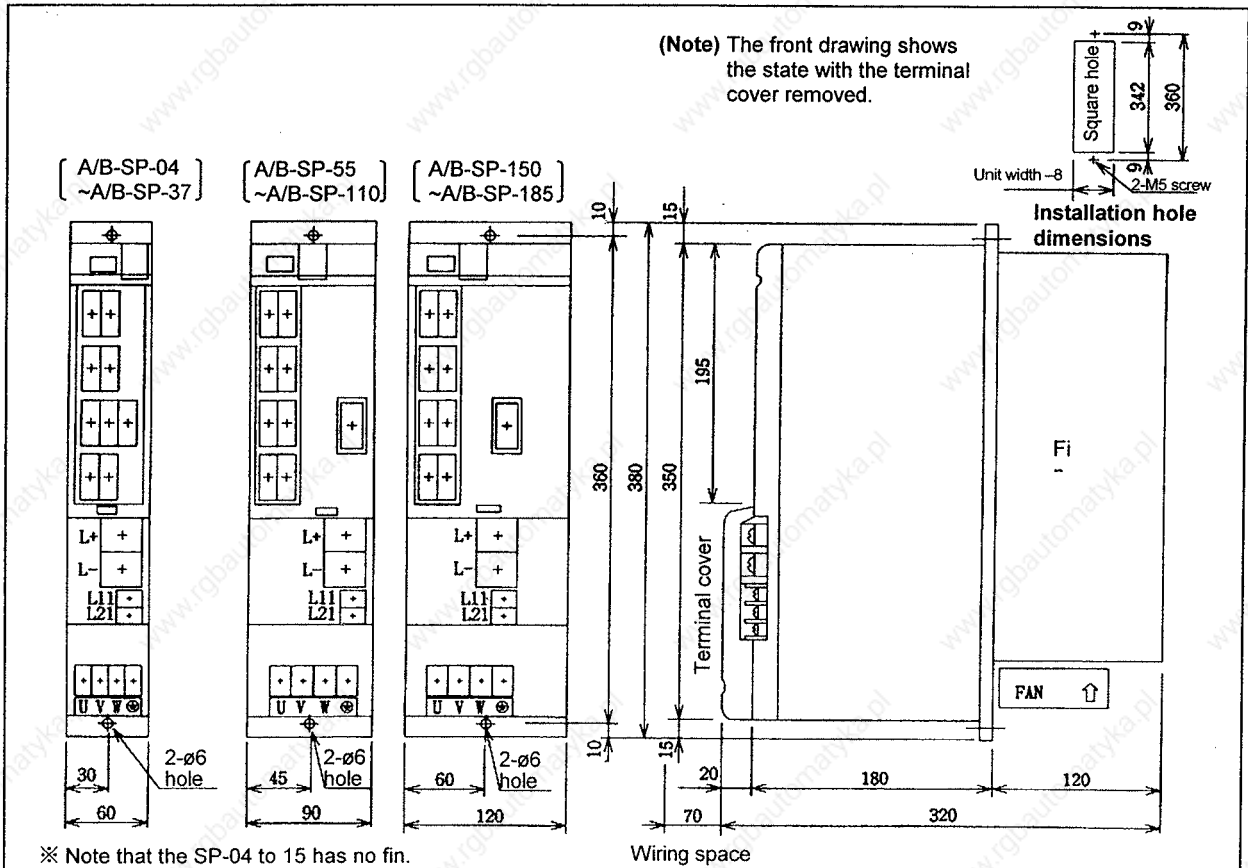

7. Heating Value

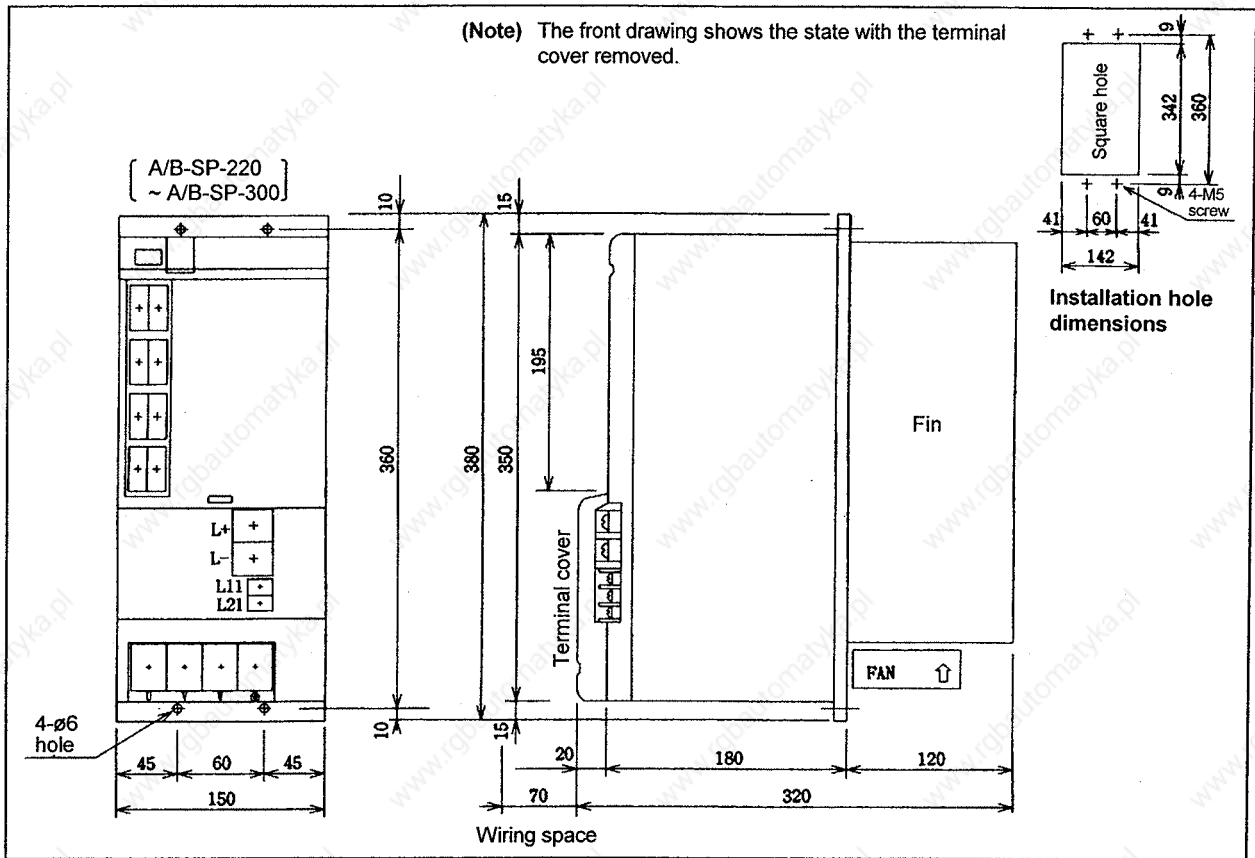

6.6 Battery unit

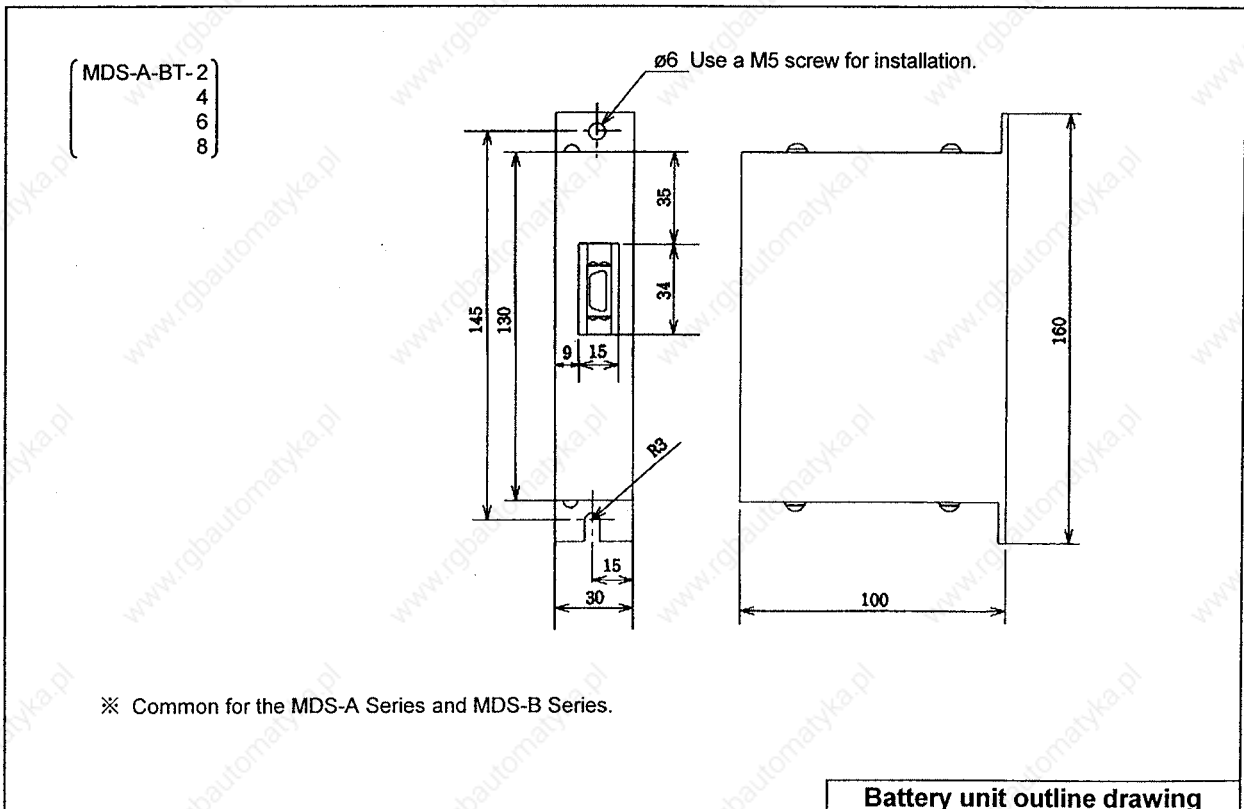

※ Common for the MDS-A Series and MDS-B Series.

7. Heating Value

6.7 AC reactor

(1) Conventional part (production terminated)

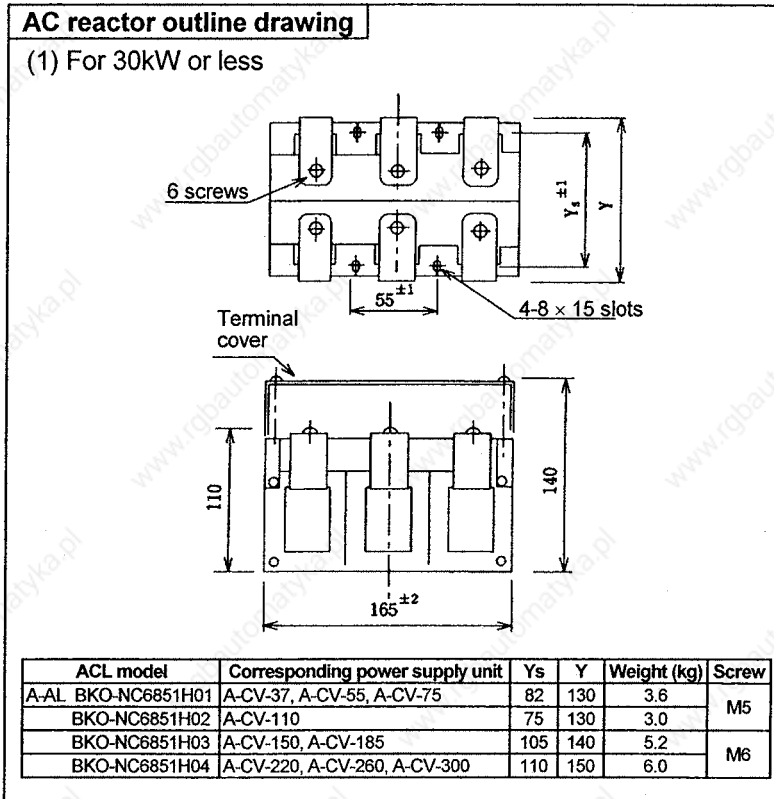

(2) European Standards compliant part

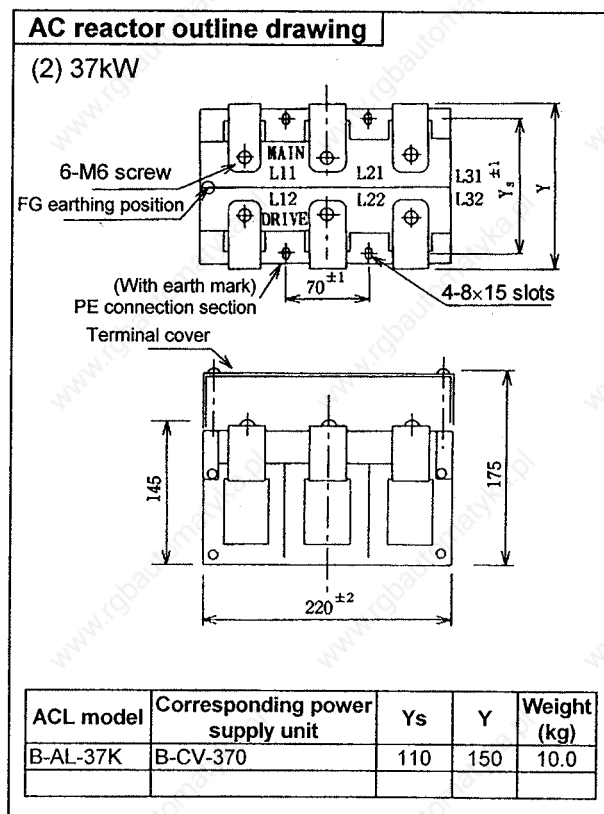
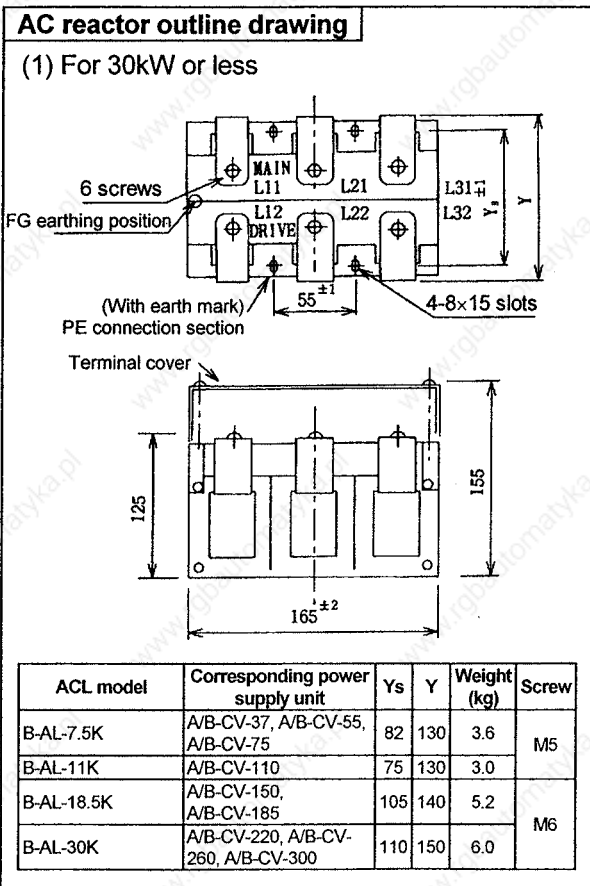

7. Heating Value

Note 1. This AC reactor has a PE (protection earthing) terminal for electric shock prevention and an FG (function earthing) terminal for noise measures. Observe the following cautions for treating each terminal.

① PE terminal (⊕)

- a. When AC reactor installation side is PE
Install the AC reactor unit with screws (bolts) in all four installation holes.
Always insert a loosening-prevention washer and spring washer in the screw (bolt) used for the ⊕ mark installation hole, and tighten the screw.
- b. When AC reactor installation side is not PE
Install the AC reactor unit with screws (bolts) in all four installation holes.
Always insert a loosening-prevention washer and spring washer and tighten the screw together with the earthing wire (PE) crimp terminal at the ⊕ mark installation hole.
The earthing wire used is the same type as the earthing wire connected to the power supply unit.

② FG terminal (FG)

Screw the function earthing wire crimp terminal at the terminal marked as "FG" on the top of the AC reactor (terminal block).

(With this treatment, the built-in filter's earth will be directly connected to the earth, and the noise withstand level will be improved.)

- * Function earthing wire:
This is an earthing wire not used for protection earthing. Thus, do not use a green/yellow spiral wire.

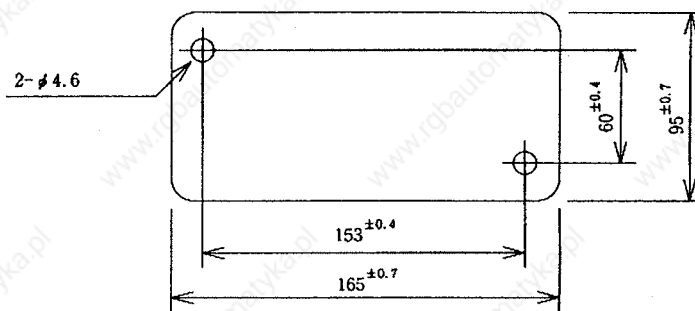

Note 2. The dimensions of the terminal cover are as shown on the right. When separately manufacturing a cover, refer to the dimensions on the right.

6.8 Dynamic brake unit

(Unit : mm)

Technical drawing of the dynamic brake unit. The front view shows dimensions A, B, C, D, and E. The side view shows dimensions F, G, and 2.3. The front view also shows a dimension of 100 and 5.

| Model | MDS-B-DBU-150 |
|----------------------------|---------------|
| A | 200 |
| B | 190 |
| C | 140 |
| D | 20 |
| E | 5 |
| F | 200 |
| G | 193.8 |
| Weight (kg) | 2 |
| Applicable servo amplifier | V1-110/150 |

6.9 Contactor

Refer to the section 8.4 Selection of AC reactor, contactor and NFB.

6.10 NFB

Refer to the section 8.4 Selection of AC reactor, contactor and NFB.

7. Heating Value

7. Heating Value

1) Power supply unit

| Model | Heating value (W) | |
|--------|-------------------|----------|
| | A series | B series |
| CV-37 | 55 | 55 |
| CV-55 | 65 | 65 |
| CV-75 | 80 | 80 |
| CV-110 | 130 | 125 |
| CV-150 | 160 | 155 |
| CV-185 | 200 | 195 |
| CV-220 | 220 | 210 |
| CV-260 | 270 | 260 |
| CV-300 | 330 | 320 |
| CV-370 | – | 400 |

2) Spindle drive unit

| Model | Heating value (W) | |
|--------|-------------------|----------|
| | A series | B series |
| SP-04 | * 30 | * 30 |
| SP-075 | * 45 | * 40 |
| SP-15 | * 55 | * 50 |
| SP-22 | 70 | 70 |
| SP-37 | 80 | 80 |
| SP-55 | 110 | 110 |
| SP-75 | 140 | 140 |
| SP-110 | 190 | 185 |
| SP-150 | 250 | 240 |
| SP-185 | 360 | 350 |
| SP-220 | 390 | 375 |
| SP-260 | 510 | 495 |
| SP-300 | 650 | 635 |

3) 1-axis servo drive unit 4) 2-axis servo drive unit

| Model | Heating value (W) | |
|--------|-------------------|----------|
| | A series | B series |
| V1-01 | * 20 | * 20 |
| V1-03 | * 25 | * 25 |
| V1-05 | * 35 | * 35 |
| V1-10 | 55 | * 50 |
| V1-20 | 80 | 80 |
| V1-35 | 115 | 115 |
| V1-45 | 165 | 160 |
| V1-70 | 255 | 245 |
| V1-90 | 295 | 285 |
| V1-110 | – | 400 |
| V1-150 | – | 550 |

| Model | Heating value (W) | |
|---------|-------------------|----------|
| | A series | B series |
| V2-0101 | 40 | 35 |
| V2-0303 | 45 | 40 |
| V2-0503 | 60 | 50 |
| V2-0505 | 70 | 60 |
| V2-1005 | 90 | 75 |
| V2-1010 | 110 | 90 |
| V2-2010 | 140 | 135 |
| V2-2020 | 160 | 155 |
| V2-3510 | 170 | 165 |
| V2-3520 | 190 | 185 |
| V2-3535 | 230 | 225 |
| V2-4520 | – | 230 |
| V2-4535 | – | 265 |

(Note 1) The heating value for the spindle drive unit is for during continuous rated output; and for the servo drive unit is for during rated output.

(Note 2) For the total heating value for the amplifier, add the heating value for the corresponding unit above that is mounted on the actual machine.

Example) When mounted unit is B-CV-185, B-SP-110, B-V1-35, B-V2-2020
 Total amplifier heating value (W) = 195 + 185 + 115 + 155 = 650 (W)

(Note 3) When using the fully closed installation method, the heating value outside the panel should follow equation ④ below.

| | MDS-A Series | MDS-B Series |
|-----------------------------|--|---|
| (1) Power supply unit | Heating value outside panel = (A-CV heating value –17) × 0.8 | Heating value outside panel = (B-CV heating value –15) × 0.85 |
| (2) Spindle drive unit | Heating value outside panel = (A-SP heating value –20) × 0.8 | Heating value outside panel = (B-SP heating value –20) × 0.85 |
| (3) 1-axis servo drive unit | Heating value outside panel = (A-V1 heating value –16) × 0.8 | Heating value outside panel = (B-V1 heating value –15) × 0.85 |
| (4) 2-axis servo drive unit | Heating value outside panel = (A-V2 heating value –28) × 0.8 | Heating value outside panel = (B-V2 heating value –20) × 0.85 |

However, the units marked with * above are types without fins, so the heating value inside the panel will be applied instead of equation ④.

(Note 4) When designing the panel for the fully closed installation, consider the actual load ratio as the heating value inside the servo drive unit panel, and use the following equation.

$$\text{Heating value inside servo drive unit panel (considering load ratio)} = \text{heating value inside panel obtained with equation ④} \times 0.5$$

(However, this excludes the power supply unit and spindle drive unit.)

If it is clear that the load ratio is larger than 0.5, substitute that load ratio for (× 0.5) in the above equation.

Example) If the mounted servo drive unit is B-V1-35:
 Heating value inside panel (during rated output)
 = 115 – (115 – 15) × 0.85 = 30 (W)
 Thus,
 Heating value inside panel (considering load ratio)
 = 30 × 0.5 = 15 (W).

(Inside panel)
 Velocity 2m/sec or more

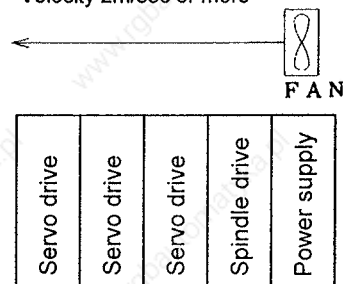

(Note 5) Due to the structure, heat will tend to accumulate that the top of each unit. Thus, install a fan in the distribution panel to mix the heat at the top of each unit.

8. Selection of Capacity

8.1 Selection of power supply unit

The selection will differ according to the following standards.

- 1) When using 1-axis servomotor

$$\text{Power supply unit capacity} > \Sigma (\text{Spindle motor output}) + (\text{Servomotor output}) \quad \text{..... } \textcircled{1}$$

- 2) When using 2 or more axes servomotor

$$\text{Power supply unit capacity} > \Sigma (\text{Spindle motor output}) + 0.7 \times \Sigma (\text{Servomotor output}) \quad \text{..... } \textcircled{2}$$

(Note 1) Σ (spindle motor output) is the total of the spindle motor's 30 minute rated output (kW).

Σ (servomotor output) is the total of the servomotor rated output (kW).

Note that, the motor output and drive unit capacity will not always match (for example, servo drive unit for servomotor HA103=2kW is V1-35=3.5kW). Thus, substitute the motor rated output instead of the drive unit capacity in the spindle motor output and servomotor output items in equations ① and ② above.

Furthermore, the spindle motor is used with differing outputs during the acceleration and constant speeds, so in this case, substitute the larger output in the spindle motor output item.

(Note 2) The power supply unit capacity is the minimum line up capacity that establishes equations ① and ②.

Example 1) If the value obtained on the right side of equations ① and ② is 10kW, the power supply unit capacity will be 11kW (CV-110)

Example 2) If the value obtained on the right side of equations ① and ② is 23kW, the power supply unit capacity will be 26kW (CV-260)

(Note 3) With the power regenerative type power supply CV, if the value obtained on the right of equations ① and ② is suppressed to less than 0.5kW more than line up CV unit capacity, the excessive amount can be ignored when selecting the CV unit capacity. For capacities exceeding 22kW, excessive values can be ignored when selecting the CV unit capacity.

Example 1) If the value obtained on the right sides of equations ① and ② is 15.5kW, the power supply unit capacity will be 15kW.

Example 2) If the value obtained on the right sides of equations ① and ② is 15.6kW, the power supply unit capacity will be 18.5kW.

Example 3) If the value obtained on the right sides of equations ① and ② is 22.9kW, the power supply unit capacity will be 22kW.

Example 4) If the value obtained on the right sides of equations ① and ② is 23.1kW, the power supply unit capacity will be 26kW.

With the resistance regeneration type power supply CR, when the capacity is 3.7kW to 9kW, if the value obtained on the right of equations ① and ② is suppressed to less than 0.5kW more than the line up CR unit capacity, the excessive amount can be ignored.

8. Selection of Capacity

(Note 4) If the value obtained on the right sides of equations ① and ② is larger than 31kW, there is no corresponding power supply unit. Thus,

<1> When Σ (spindle motor output) < 31kW

Power supply unit (No. 1) capacity > Σ (spindle motor output)

Power supply unit (No. 2) capacity > $k \times \Sigma$ (servomotor output)

* However, select two power supply units so that coefficient k is k=1 when the servomotor has one axis; and k=0.7 when the servomotor has two or more axes.

<2> When Σ (spindle motor output) > 38kW

Power supply unit (No. 1) capacity > Σ (spindle motor output 1)

* Where, Σ (spindle motor output 1) is the total of the spindle motor output that is 38kW or less.

Power supply unit (No. 2) capacity
> Σ (spindle motor output 2) + $K \times \Sigma$ (servomotor output)

* Where, two power supply units for Σ (spindle motor output 2) so that the spindle motor output coefficient k that is not added to the power supply unit (No. 1) is k=1 when the servomotor has one axis and k=0.7 when the servomotor has two or more axes.

<3> If the value obtained on the right sides of equations ① and ② is more than 76kW, three or more power supply units will be required. However, even in this case, the same selection method as <2> is used.

(Note 5) When the servomotor has two or more axes, the value is calculated as k = 0.7. However, if the capacity of the power supply unit determined by the calculation is smaller than the largest output of the servomotor being used, select a power supply unit capacity that is the same as the largest servomotor output.

8. Selection of Capacity

8.2 Selection of power supply capacity

The power supply capacity reference values for the power supply unit selected in section 8.1 are as follow:

| Power regeneration type power supply unit | A/B-CV-37 | A/B-CV-55 | A/B-CV-75 | A/B-CV-110 | A/B-CV-150 | A/B-CV-185 | A/B-CV-220 | A/B-CV-260 | A/B-CV-300 | B-CV-370 |
|--|-----------|-----------|-----------|------------|------------|------------|------------|------------|------------|----------|
| Power supply capacity reference values (kVA) | 7 | 9 | 12 | 17 | 23 | 28 | 33 | 37 | 44 | 54 |

| Resistance regeneration type power supply unit | A-CR-10/15 | A-CR-22 | A-CR-37 | A-CR-55 | A-CR-75 | A-CR-90 |
|--|------------|---------|---------|---------|---------|---------|
| Power supply capacity reference values (kVA) | 3 | 4 | 7 | 9 | 12 | 17 |

The actually required power supply capacity is calculated with the following equation based on the above power supply capacity reference values.

| |
|--|
| $\text{Power supply capacity (kVA)} = \frac{\text{Right side value (kW) obtained in equations ① and ② in section 8.1}}{\text{Power supply unit capacity (kW) selected from section 8.1}} \times \text{power supply capacity reference value (kVA)} \dots\dots\dots \text{③}$ |
|--|

When using multiple power supply units, the total of the power supply capacity for each power supply unit obtained in equation ③ will be the total power supply capacity.

Example) When the value obtained in 8.1 equations ① and ② is 13.5kW, the CV-150 power supply unit will be selected, so the power supply capacity reference value (kVA) will be 23. Thus, from equation ③, the power supply capacity (kVA) will be $(13.5/15) \times 23 = 20.7$ (kVA).

8. Selection of Capacity

8.3 Selection of wire size

(1) Recommended power lead-in wire size

Select the wire size based on the power supply unit capacity as shown below regardless of the motor type.

| | A-CR-10 A-CR-15 A-CR-22 | A/B-CV-37 A-CR-37 | A/B-CV-55 A-CR-55 | A/B-CV-75 A-CR-75 A-CR-90 | A/B-CV-110 | A/B-CV-150 | A/B-CV-185 | A/B-CV-220 |
|-------------------------------------|-------------------------------|-------------------------|---------------------------|---------------------------------|-------------------------|-------------------------|-------------------------|-------------------------|
| Recommended power lead-in wire size | IV2SQ | IV3.5SQ or HIV2SQ | IV3.5SQ or HIV3.5SQ | HIV5.5SQ | IV14SQ or HIV14SQ | IV22SQ or HIV14SQ | IV30SQ or HIV22SQ | IV38SQ or HIV30SQ |

| A/B-CV-260 | A/B-CV-300 | B-CV-370 |
|-------------------------|-------------------------|----------|
| IV50SQ or HIV38SQ | IV60SQ or HIV38SQ | HIV50SQ |

(2) Recommended wire size for spindle motor output wire

Select the wire size based on the spindle drive unit capacity as shown below regardless of the motor type.

| Spindle drive unit capacity | 0.4K | 0.75K | 1.5K | 2.2K | 3.7K | 5.5K | 7.5K | 11K |
|---|-----------------------|-----------------------|-------------------------|-------------------------|-------------------------|-------------------------|---------------------------|-------------------------|
| Recommended wire size for spindle motor output wire | IV2SQ or HIV2SQ | IV2SQ or HIV2SQ | IV3.5SQ or HIV2SQ | IV3.5SQ or HIV2SQ | IV3.5SQ or HIV2SQ | IV3.5SQ or HIV2SQ | IV5.5SQ or HIV3.5SQ | IV8SQ or HIV5.5SQ |

| 15K | 18.5K | 22K | 26K | 30K |
|-------------------------|-------------------------|-------------------------|-------------------------|-------------------------|
| IV14SQ or HIV14SQ | IV22SQ or HIV14SQ | IV30SQ or HIV22SQ | IV38SQ or HIV30SQ | IV60SQ or HIV38SQ |

(3) Recommended wire size for servomotor output wire

Select the wire size based on the servo drive unit capacity as shown below regardless of the motor type.

| Servo drive unit capacity | 0.1K | 0.3K | 0.5K | 1.0K | 2.0K | 3.5K | 4.5K | 7.0K |
|---|-----------------------------|-----------------------------|-----------------------|-----------------------|-------------------------|---------------------------|---------------------------|-------------------------|
| Recommended wire size for servo motor output wire | IV1.25SQ OR HIV1.25SQ | IV1.25SQ or HIV1.25SQ | IV2SQ or HIV2SQ | IV2SQ or HIV2SQ | IV3.5SQ or HIV2SQ | IV5.5SQ or HIV3.5SQ | IV5.5SQ or HIV3.5SQ | IV8SQ or HIV5.5SQ |

| 9.0K | 11K | 15K |
|-----------------------|-------------------------|-------------------------|
| IV8SQ or HIV8SQ | IV14SQ or HIV14SQ | IV30SQ or HIV22SQ |

(Note) The wire sizes recommended in (1) to (3) above are selected with conditions of an ambient temperature of 30°C and three wires in the same tube.
During actual use, select the wire based on the above reference while considering the ambient temperature, wire material, and wiring state.

8. Selection of Capacity

(4) Wire size for L11, L21 link bar

Regardless of the power supply unit and drive unit capacity, the wire size must be IV2SQ or more. The wire between NFB ↔ L11 and L21 must also be IV2SQ or more.

(5) Wire size for L+, L- link bar

[Selection method 1]

To unify the L+ and L- link bar size:

To unify the L+ and L- link bar size, use the wire sizes given below or a larger wire size for the L+ and L- link bar connected to the same power supply unit according to the power supply unit capacity.

| Power supply unit | A-CR-10 A-CR-15 A-CR-22 | A/B-CV-37 A-CR-37 | A/B-CV-55 A-CR-55 | A/B-CV-75 A-CR-75 | A-CR-90 | A/B-CV-110 | A/B-CV-150 |
|------------------------------|-------------------------------|-------------------------|-------------------------|---------------------------|-------------------------|------------------------|-------------------------|
| L+ and L- link bar wire size | IV2SQ | IV3.5SQ or HIV2SQ | IV3.5SQ or HIV2SQ | IV5.5SQ or HIV3.5SQ | IV8SQ or HIV5.5SQ | IV14SQ or HIV8SQ | IV14SQ or HIV14SQ |

| A/B-CV-185 | A/B-CV-220 | A/B-CV-260 | A/B-CV-300 | B-CV-370 |
|-------------------------|-------------------------|-------------------------|-------------------------|-------------------------|
| IV22SQ or HIV14SQ | IV22SQ or HIV14SQ | IV38SQ or HIV22SQ | IV60SQ or HIV38SQ | IV60SQ or HIV50SQ |

[Selection method 2]

To suppress the L+ and L- link bar size to the minimum required for each unit:

To suppress the L+ and L- link bar size to the minimum required for each unit, select the wire based on the current value that actually flows to the link bar.

The following drawing shows an example of a spindle and 3-axis servo system. The same selection method is used for other systems.

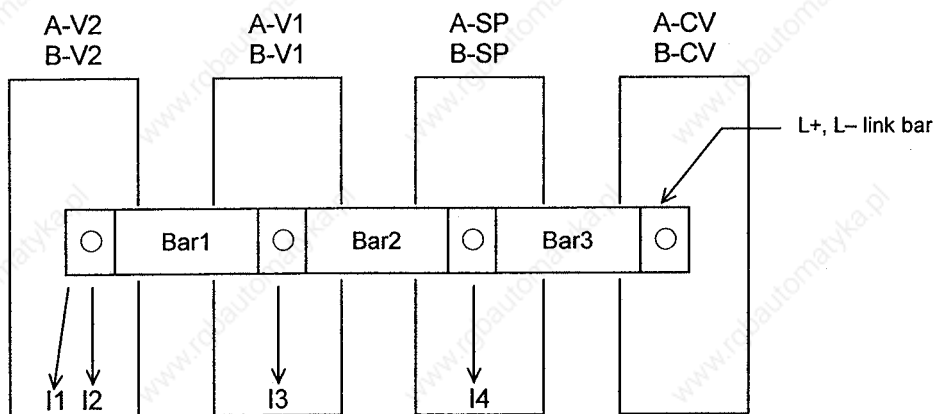

<1> If the current that flows through the L+, L- bus bars of each drive unit is I1 to I4, the current that flows through each link bar (Bar 1 to Bar 3) will be as follows:

$$\left. \begin{aligned}
 I(\text{Bar 1}) &= I_1 + I_2 \\
 I(\text{Bar 2}) &= I_1 + I_2 + I_3 \\
 I(\text{Bar 3}) &= I_1 + I_2 + I_3 + I_4
 \end{aligned} \right\} \dots\dots \textcircled{6}$$

Thus, the wire for each L+, L- link bar should tolerate the above current as a minimum.

8. Selection of Capacity

<2> The I1 to I4 values are actually obtained with the following equation:

$$(I1 \text{ to } I4) = \text{Motor output current} \times 1.1 \quad \dots\dots \textcircled{7}$$

However, the motor output current in equation $\textcircled{7}$ is obtained with the following.

(A) Spindle motor

Substitute the following according to the spindle drive unit capacity :

| | | | | | | | | | | | | | |
|------------------------------------|-------------|--------------|-------------|-------------|-------------|-------------|-------------|------------|------------|--------------|------------|------------|------------|
| Spindle drive unit capacity | 0.4K | 0.75K | 1.5K | 2.2K | 3.7K | 5.5K | 7.5K | 11K | 15K | 18.5K | 22K | 26K | 30K |
| Motor output current (A) | 4 | 6 | 10 | 17 | 25 | 30 | 40 | 60 | 74 | 94 | 103 | 127 | 165 |

(B) Servomotor

Substitute the following according to the servomotor name:

| | | | | | | | | | | | | |
|--------------------------|-----------------------|-------------|-------------|-------------|-------------|-------------|-------------|--------------|--------------|--------------|--------------|--------------|
| Motor name | HA053 HA13 | HA23 | HA33 | HA40 | HA43 | HA80 | HA83 | HA100 | HA103 | HA200 | HA203 | HA300 |
| Motor output current (A) | 1.4 | 3.0 | 3.0 | 3.6 | 5.0 | 6.6 | 8.8 | 14.0 | 19.6 | 22.0 | 34.5 | 37.0 |

| | | | | | | | | | | | | |
|--------------------------|--------------|--------------|--------------|--------------|--------------|---------------|---------------|---------------|---------------|---------------|-----------------------|-----------------------|
| Motor name | HA303 | HA700 | HA703 | HA900 | HA50L | HA100L | HA150L | HA200L | HA300L | HA500L | HA-LH 11K2 | HA-LH 15K2 |
| Motor output current (A) | 55 | 49.0 | 68 | 56.0 | 4.0 | 8.0 | 11.5 | 18.2 | 25.0 | 44.0 | 84.0 | 100.0 |

<3> Based on the values I1 to I4 obtained with equation $\textcircled{7}$, find I (Bar 1) to I (Bar 3) with equation $\textcircled{6}$. Match the obtained value with the values given below, and select the IV wire size.

| Wire size | Tolerable current |
|------------------|--------------------------|
| IV2SQ | 27 A |
| IV3.5SQ | 37 A |
| IV5.5SQ | 49 A |
| IV8SQ | 61 A |
| IV14SQ | 88 A |
| IV22SQ | 115 A |
| IV38SQ | 162 A |
| IV60SQ | 217 A |

(Ambient temperature 30°C or less)

8. Selection of Capacity

<4> A selection example is shown below.

| Drive unit | Motor | Motor output current |
|-------------|----------|----------------------|
| A/B-SP-75 | SJ-7.5A | Substitute 40A |
| A/B-V1-20 | HA100 | Substitute 14A |
| A/B-V2-1010 | HA80 × 2 | Substitute 6.6A × 2 |

* The power supply unit capacity is as follows according to equation ② in section 8.1:

Power supply unit capacity >
 $7.5 + 0.7 \times (2 + 1 + 1) = 10.3 \rightarrow 11(\text{kW})$.
 Thus, select CV-110.

For the above drive system, the following applies:

$$\begin{cases} I1 = 6.6\text{A} \times 1.1 = 7.3\text{A} \\ I2 = 6.6\text{A} \times 1.1 = 7.3\text{A} \\ I3 = 14\text{A} \times 1.1 = 15.4\text{A} \\ I4 = 40\text{A} \times 1.1 = 44.0\text{A} \end{cases}$$

Thus,

$$\begin{cases} I(\text{Bar1}) = I1 + I2 = 14.6\text{A} \\ I(\text{Bar2}) = I1 + I2 + I3 = 30.0\text{A} \\ I(\text{Bar3}) = I1 + I2 + I3 + I4 = 74.0\text{A} \end{cases}$$

Therefore, the following is selected according to the table in <3>:

$$\begin{cases} \text{Bar1} \dots\dots \text{IV2SQ} \\ \text{Bar2} \dots\dots \text{IV3.5SQ} \\ \text{Bar3} \dots\dots \text{IV14SQ} \end{cases}$$

(6) Amplifier connection screw size

The screw size for each unit is as follows.

| | Resistance regeneration type power supply unit | Power regeneration type power supply unit | | | | Spindle drive unit | | | | Servo drive unit | | | | | |
|---------------|--|---|----|---------|-------|--------------------|--------|---------|-------|------------------|-----|-----|--------|-------|-----------|
| | | | | | | | | | | 1-axis | | | 2-axis | | |
| Capacity (kW) | 1.0~9.0 | ~7.5 | 11 | 15~18.5 | 22~37 | ~3.7 | 5.5~11 | 15~18.5 | 22~30 | ~3.5 | 4.5 | 7~9 | 11~15 | ~2 *2 | ~4.5 *3.5 |
| Unit width | 60 | 60 | 90 | 120 | 150 | 60 | 90 | 120 | 150 | 60 | 90 | 120 | 150 | 60 | 90 |
| L1, L2, L3, ⊕ | M4 | M4 | M5 | M5 | M8 | - | - | - | - | - | - | - | - | - | - |
| U, V, W, ⊕ | - | - | - | - | - | M4 | M5 | M5 | M8 | M4 | M5 | M5 | M8 | M4 | M5 |
| L+, L- | M6 | M6 | M6 | M6 | M6 | M6 | M6 | M6 | M6 | M6 | M6 | M6 | M6 | M6 | M6 |
| L11, L21 | - | M4 | M4 | M4 | M4 | M4 | M4 | M4 | M4 | M4 | M4 | M4 | M4 | M4 | M4 |
| MC1 | M4 | M4 | M4 | M4 | M4 | - | - | - | - | - | - | - | - | - | - |
| MC2, C | M4 | - | - | - | - | - | - | - | - | - | - | - | - | - | - |

8. Selection of Capacity

- (7) Select the wire size as follows for EC Directive compliance. (The sizes are all mm² units.)
The wire types are as follow.

PVC : Polyvinyl chloride
EPR : Ethylene polypropylene
SIR : Silicone rubber

- ① MDS-A/B-CV (L1, L2, L3, PE)

| Unit | | 37 | 55 | 75 | 110 | 150 | 185 | 220 | 260 | 300 | 370 |
|---------------------|-----|-----|-----|-----|-----|-----|-----|-----|-----|-----|-----|
| Wire | PVC | 2.5 | 2.5 | 4 | 6 | 10 | 16 | 25 | 35 | 50 | 70 |
| | EPR | 1.5 | 2.5 | 4 | 6 | 10 | 16 | 25 | 35 | 35 | 50 |
| | SIR | 1.0 | 1.5 | 2.5 | 4 | 6 | 10 | 16 | 16 | 25 | 25 |
| Terminal screw size | | M4 | | | M5 | | | M8 | | | |

- ② MDS-A/B-SP (U, V, W, PE)

| Unit | | 04 | 075 | 15 | 22 | 37 | 55 | 75 | 110 | 150 | 185 | 220 | 260 | 300 |
|---------------------|-----|-----|-----|-----|-----|-----|-----|-----|-----|-----|-----|-----|-----|-----|
| Wire | PVC | 1.0 | 1.0 | 1.0 | 1.0 | 1.5 | 2.5 | 4 | 6 | 10 | 16 | 25 | 35 | 70 |
| | EPR | 1.0 | 1.0 | 1.0 | 1.0 | 1.5 | 2.5 | 4 | 6 | 10 | 16 | 25 | 35 | 50 |
| | SIR | 1.0 | 1.0 | 1.0 | 1.0 | 1.0 | 1.0 | 2.5 | 4 | 6 | 10 | 10 | 16 | 25 |
| Terminal screw size | | M4 | | | | M5 | | | | M8 | | | | |

- ③ MDS-A/B-V1, V2 (U, V, W, PE)

| Unit | | 01 | 03 | 05 | 10 | 20 | 35 | 45 | 70 | 90 | 110 | 150 |
|---------------------|-----|-----|-----|-----|-----|-----|-----|-----|-----|----|-----|-----|
| Wire | PVC | 1.0 | 1.0 | 1.0 | 1.0 | 1.5 | 2.5 | 4 | 6 | 10 | 25 | 35 |
| | EPR | 1.0 | 1.0 | 1.0 | 1.0 | 1.0 | 1.5 | 4 | 6 | 10 | 16 | 25 |
| | SIR | 1.0 | 1.0 | 1.0 | 1.0 | 1.0 | 1.0 | 2.5 | 2.5 | 4 | 10 | 16 |
| Terminal screw size | | M4 | | | | | | M5 | | M8 | | |

- ④ Wire size for L11 and L21 link bar

Regardless of the power supply unit and drive unit capacity, the wire size must be 1.5mm² or more. (This also applies to the wire between NPB-L11 and L21.)

- ⑤ Wire size for L+ and L- link bar (for size unification)

| Power supply unit | A-CV-37 | A-CV-55 | A-CV-75 | A-CV-110 | A-CV-150 | A-CV-185 | A-CV-220 | A-CV-260 | A-CV-300 | A-CV-370 | |
|---------------------|---------|---------|---------|----------|----------|----------|----------|----------|----------|----------|----|
| Wire | PVC | 2.5 | 2.5 | 6 | 10 | 16 | 25 | 35 | 50 | 70 | — |
| | EPR | 1.5 | 2.5 | 4 | 10 | 16 | 25 | 35 | 35 | 70 | 70 |
| | SIR | 1.0 | 1.5 | 2.5 | 4 | 10 | 10 | 16 | 25 | 35 | 35 |
| Terminal screw size | | M6 | | | | | | | | | |

- ※ The above wire sizes follow EN60204 under the following conditions.

- Ambient temperature: 40°C
- Wire installed on wall or open cable tray

When using under other conditions, refer to Table 5 of EN60204 and Appendix C.

8. Selection of Capacity

8.4 Selection of AC reactor, contactor and NFB

<1> Select the AC reactor, contactor and NFB from the following table when using only one power supply unit.

| Power supply unit capacity | ~ 7.5kW | 11kW | 15 ~ 18.5kW | 22 ~ 30kW | 37kW | | | | | | | | | | | | | | | | | | | | | | |
|---|---|----------------|------------------|------------------|------------------|---------------------------------|----|--------------------------------|-----------|-----------|-----|-----|--|----------------------------|-----------|-----------|--------------------------------|------|------|------|------|------|------|--|--------------------------------|------|------|
| AC reactor (ordered product) | B-AL-7.5K (Mitsubishi Electric) * Refer to section 6. Outline Drawing for the dimensions | B-AL-11K | B-AL-18.5K | B-AL-30K | B-AL-37K | | | | | | | | | | | | | | | | | | | | | | |
| Recommended contactor (non-ordered part) | SK25-AC200V (Mitsubishi Electric) * Refer to section 6. Outline Drawing for the dimensions | SK35-AC200V | SK50-AC200V | SK80-AC200V | SK150-AC200V | | | | | | | | | | | | | | | | | | | | | | |
| Recommended NFB1 (non-ordered part) | NF50CS3P-40A05 (Mitsubishi Electric) * Refer to section 6. Outline Drawing for the dimensions | NF50CS3P-50A05 | NF100CS3P-100A05 | NF225CS3P-150A05 | NF225CS3P-175A05 | | | | | | | | | | | | | | | | | | | | | | |
| Recommended NFB2 (non-ordered part) | <p>An NFB or CP (circuit protector) can be used as the breaker for the motor fan. Select the NFB or CP by doubling the motor fan rated current value as a guideline. Contact the NFB or CP maker for the recommended wire size.</p> <table border="1" style="width: 100%; border-collapse: collapse;"> <tr> <td style="text-align: center;">Spindle motor frame size</td> <td style="text-align: center;">71</td> <td style="text-align: center;">90</td> <td style="text-align: center;">112</td> <td style="text-align: center;">132</td> <td style="text-align: center;">160</td> <td style="text-align: center;">180</td> <td style="width: 20px;"></td> <td style="text-align: center;">Servomotor capacity</td> <td style="text-align: center;">HA-LH11K2</td> <td style="text-align: center;">HA-LH15K2</td> </tr> <tr> <td style="text-align: center;">Motor fan rated current</td> <td style="text-align: center;">0.1A</td> <td style="text-align: center;">0.2A</td> <td style="text-align: center;">0.2A</td> <td style="text-align: center;">0.2A</td> <td style="text-align: center;">0.6A</td> <td style="text-align: center;">0.6A</td> <td></td> <td style="text-align: center;">Motor fan rated current</td> <td style="text-align: center;">0.2A</td> <td style="text-align: center;">0.2A</td> </tr> </table> <p>* A rush current that is approximately double the above rated current will flow when the fan is started.</p> | | | | | Spindle motor frame size | 71 | 90 | 112 | 132 | 160 | 180 | | Servomotor capacity | HA-LH11K2 | HA-LH15K2 | Motor fan rated current | 0.1A | 0.2A | 0.2A | 0.2A | 0.6A | 0.6A | | Motor fan rated current | 0.2A | 0.2A |
| Spindle motor frame size | 71 | 90 | 112 | 132 | 160 | 180 | | Servomotor capacity | HA-LH11K2 | HA-LH15K2 | | | | | | | | | | | | | | | | | |
| Motor fan rated current | 0.1A | 0.2A | 0.2A | 0.2A | 0.6A | 0.6A | | Motor fan rated current | 0.2A | 0.2A | | | | | | | | | | | | | | | | | |

(Note) The following applies to the above table:

- ① Ordered parts refer to parts ordered by the user and shipped from Mitsubishi.
- ② Non-ordered parts refer to parts not ordered, but arranged by the user.

(Note) Use the EN/IEC Standards compliant parts for the contactor and NFB to comply with the EC Directives.

8. Selection of Capacity

<2> Select the batch NFB1 and contactor as follows when using two or more power supply units.

(A) NFB1, contactor

(Note) With the MDS-B-CV-370, the contactor cannot be shared with other power supplies.

$$\text{Total input current (A)} = \text{CV (No.1) input current (A)} + \text{CV (No.2) input current (A)}$$

Substitute the following for the above equation of right side and obtained the total input current (A):

| | | | | | | |
|--------------------------|--------------------|---------------------------------|----------------------|----------------------|-----------------------|------------|
| Power supply unit | A-CR-10 A-CR-15 | A/B-CV-37 A-CR-22 A-CR-37 | A/B-CV-55 A-CR-55 | A/B-CV-75 A-CR-75 | A-CR-90 A/B-CV-110 | A/B-CV-150 |
| Input current (A) | 10 | 20 | 30 | 40 | 60 | 70 |

| | | | | |
|------------|------------|------------|------------|----------|
| A/B-CV-185 | A/B-CV-220 | A/B-CV-260 | A/B-CV-300 | B-CV-370 |
| 80 | 100 | 120 | 135 | 160 |

Substitute the total input current (A) value in the following :

- { NFB1 Rated current (A) in recommended NFB1 table
- { Contactor..... Rated conductivity current (A) in recommended contactor table

Select the NFB1 and contactor having a rated current larger than the total input current.

<3> The AC reactor cannot be shared between two and more power supply units. Always use one AC reactor for each power supply unit.

8. Selection of Capacity

[Reference for contactor selection]

Mitsubishi Electric contactor

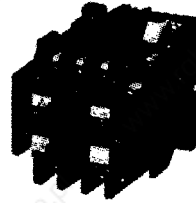
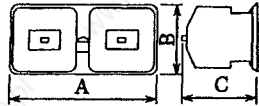
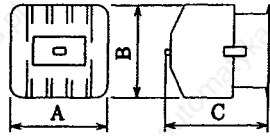

S-K21 type

AC operation AC electromagnetic contactor

| Name | Model | AC Class 3 rated working current (A) | | Rated conductivity current (A) | Support contact | | Dimensions (mm) | | |
|---------------------|--------|--------------------------------------|------------|--------------------------------|-----------------|---------|-----------------|-----|------|
| | | 200 ~ 220V | 380 ~ 440V | | Standard | Special | A | B | C |
| Open type | S-K10 | 11 | 7 | 20 | 1a | 1b | 44 | 66 | 78 |
| Non-reversible type | S-K11 | 13 | 9 | 20 | 1a | 1b | 44 | 66 | 78 |
| | S-K12 | 13 | 9 | 20 | 1a1b | 2a | 53 | 66 | 75 |
| | S-K18 | 18 | 13 | 25 | — | — | 45 | 67 | 87.5 |
| | S-K20 | 20 | 20 | 32 | 1a1b | 2a | 68 | 78 | 88 |
| | S-K21 | 20 | 20 | 32 | 2a2b | — | 68 | 78 | 96 |
| | S-K25 | 26 | 24 | 50 | 2a2b | — | 80 | 89 | 102 |
| | S-K35 | 35 | 32 | 60 | 2a2b | — | 80 | 89 | 102 |
| | S-K50 | 50 | 46 | 80 | 2a2b | — | 88 | 106 | 106 |
| | S-K65 | 65 | 62 | 100 | 2a2b | — | 88 | 106 | 106 |
| | S-K80 | 80 | 75 | 135 | 2a2b | 4a4b | 100 | 124 | 127 |
| | S-K95 | 93 | 93 | 135 | 2a2b | 4a4b | 100 | 124 | 127 |
| | S-K100 | 100 | 100 | 150 | 2a2b | 4a4b | 100 | 150 | 136 |
| | S-K125 | 125 | 120 | 150 | 2a2b | 4a4b | 100 | 150 | 136 |
| | S-K150 | 150 | 150 | 200 | 2a2b | 4a4b | 120 | 160 | 145 |
| | S-K180 | 180 | 180 | 260 | 2a2b | 4a4b | 138 | 204 | 174 |
| | S-K220 | 220 | 220 | 260 | 2a2b | 4a4b | 138 | 204 | 174 |
| S-K300 | 300 | 300 | 350 | 2a2b | 4a4b | 163 | 243 | 195 | |
| S-K400 | 400 | 400 | 450 | 2a2b | 4a4b | 163 | 243 | 195 | |
| S-K600 | 630 | 630 | 660 | 2a2b | 4a4b | 290 | 310 | 234 | |
| S-K800 | 800 | 800 | 800 | 2a2b | 4a4b | 290 | 310 | 234 | |

Note 1. The contactor is currently being switched from the "S-K Series" to the "S-N Series".

There are some types for which the installation dimensions are not compatible. Thus, confirm before purchasing.

Note 2. Noise is generated when the contactor turns ON to OFF, so use of a type with built-in surge absorber is recommended.

8. Selection of Capacity

[Reference for NFB selection]

Mitsubishi Electric NFB

| Frame A | | 30 | | 50 | | 60 | | 100 | | 225 | | 400 | | 600 | | 800 | |
|--|--|---|--|-------------------------------------|--|---|--|---------------------------------|--|--------------------------------------|--|---------------------------------|--|-------------------------------|--|-------------------------------|--|
| Model | | NF30-CB | | NF50-CP | | NF60-CP | | NF100-CP | | NF225-CP | | NF400-CS | | NF600-CS | | NF800-CS | |
| Appearance | | | | | | | | | | | | | | | | | |
| Rated current (A) Reference ambient temp. General use: 40°C For ships : 45°C | | 3 5 10 15 20 30 | | 10 15 20 30 40 50 | | (10)(15)(20) (30)(40)(50) 60 (*2) | | (50) 60 75 100 | | (*3) (100) 125 150 175 200 225 | | 250 300 350 400 | | 500 600 | | Adjustable 600 700 800 | |
| No. of poles | | 2 3 | | 2 3 | | 2 3 | | 2 3 | | 2 3 | | 2 3 | | 3 | | 3 | |
| Rated voltage (V) | | AC 250 DC — | | 600 (*) 250 | | 600 (*) 250 | | 600 (*) 250 | | 600 (*) 250 | | 600 (*) 250 | | 600 (*) 250 | | 600 | |
| JIS (sym) | | AC 550V — 460V — 220V 2.5 | | 1.5 2.5 5 | | 1.5 2.5 5 | | 7.5 10 25 | | 10 15 25 | | 15 25 35 | | 18 35 50 | | 18 35 50 | |
| IEC [IEC157-1] [BS4752-1] [P1] (svm) | | DC 250V — 500V — 415V — 380V — 240V 2.5 | | 2.5 — 2.5 5 | | 2.5 — 2.5 5 | | 7.5 — 7.5 10 | | 10 — 10 15 | | 20 — 25 35 | | 20 — 25 35 | | 20 — 25 35 | |
| NK (sym) | | AC 250V 2.5 DC 250V — | | 5 2.5 | | 5 2.5 | | 25 7.5 | | 25 10 | | 35 25 | | 50 35 | | 50 35 | |
| Dimensions (mm) | | | | a 45 67.5 b 96 c 52 c a 67 | | 50 75 130 68 86 | | 50 75 130 68 86 | | 60 90 155 68 86 | | 105 140 86 110 | | 140 257 103 132 | | 210 275 103 155 | |
| Surface type product weight (kg) | | 0.25 0.35 | | 0.45 0.65 | | 0.45 0.65 | | 0.85 1.1 | | 2.0 2.5 | | 5.0 5.8 | | 9.5 | | 10.9 | |
| Connection methods | | Page | | 82 | | 82 | | 82 | | 82 | | 82 | | 82 | | 82 | |
| Surface type (F) | | For crimp terminal | | For crimp terminal | | For crimp terminal | | With barrier for crimp terminal | | With barrier for crimp terminal | | With bar terminal and barrier | | With bar terminal and barrier | | With bar terminal and barrier | |
| Rear surface type (B) | | — | | Round stud | | Round stud | | Round stud | | Bar stud | | Bar stud | | Bar stud | | Bar stud | |
| Inlaid type (FP) | | — | | — | | — | | — | | — | | — | | — | | — | |
| Insertion type (PM) | | — | | — | | — | | — | | — | | — | | — | | — | |
| With accessory devices | | 92 | | 92 | | 92 | | 92 | | 92 | | 92 | | 92 | | 92 | |
| Alarm switch (AL) | | — | | — | | — | | — | | — | | — | | — | | — | |
| Auxiliary switch (AX) | | — | | — | | — | | — | | — | | — | | — | | — | |
| Voltage trip device (SHT) | | — | | — | | — | | — | | — | | — | | — | | — | |
| Undervoltage trip device (UVT) | | — | | — | | — | | — | | — | | — | | — | | — | |
| Electrical operation type (NFM) | | 118 | | 118 | | 118 | | 118 | | 118 | | 118 | | 118 | | 118 | |
| Machine interlock (M1) | | — | | △ | | △ | | △ | | △ | | △ | | △ | | △ | |
| Lead wire terminal block (LT) | | 97 | | 97 | | 97 | | 97 | | 97 | | 97 | | 97 | | 97 | |
| Boxed | | 106 | | 106 | | 106 | | 106 | | 106 | | 106 | | 106 | | 106 | |
| Closed type (S) | | — | | — | | — | | — | | — | | — | | — | | — | |
| Dust-proof type (1) | | — | | — | | — | | — | | — | | — | | — | | — | |
| Waterproof type (W) | | — | | — | | — | | — | | — | | — | | — | | — | |
| Optional parts | | 116 | | 116 | | 116 | | 116 | | 116 | | 116 | | 116 | | 116 | |
| Door lock device (*4) (HL) (LC) | | — | | — | | — | | — | | — | | — | | — | | — | |
| Operation door handle (TOTTE) | | 98 | | 98 | | 98 | | 98 | | 98 | | 98 | | 98 | | 98 | |
| F type | | — | | — | | — | | — | | — | | — | | — | | — | |
| S type | | — | | — | | — | | — | | — | | — | | — | | — | |
| Terminal cover (TC-L, S) (BTC) | | 110 | | 110 | | 110 | | 110 | | 110 | | 110 | | 110 | | 110 | |
| Surface stud (B-ST) | | 84 | | 84 | | 84 | | 84 | | 84 | | 84 | | 84 | | 84 | |
| Inlaid installation frame | | 84 | | 84 | | 84 | | 84 | | 84 | | 84 | | 84 | | 84 | |
| Insert terminal block | | 85 | | 85 | | 85 | | 85 | | 85 | | 85 | | 85 | | 85 | |
| Electrical part type approval (▽ obtained) | | ▽ | | ▽ | | ▽ | | ▽ | | — | | — | | — | | — | |
| Approval from Shipping Federation (☆ obtained, □ pending) (NK, LR, BV, AB, GL) | | ☆ (Excluding AB) | | — | | ☆ | | ☆ | | ☆ | | ☆ | | ☆ NK, AB, LR □ GL | | — | |
| Standard trip method | | Fully electromagnetic | | Fully electromagnetic | | Fully electromagnetic | | Fully electromagnetic | | Heat — electromagnetic | | Heat-adjustable electromagnetic | | Electronic (adjustable) | | — | |
| Trip button | | — | | Yes | | Yes | | Yes | | Yes | | Yes | | Yes | | Yes | |
| Outline / characteristics page | | 124 | | 126 | | 132 | | 136 | | 144 | | 154 | | 160 | | 166 | |

(Notes) *1 : Specify when using for DC.

*2 : The same structure as NF50-CS will be used for 50A or less.

*3 : The NF225-CS rated current 100A indicates the shut-off capacity for the rated voltage 380VAC or higher (JIS, IEC)

II. MDS-A-CV, MDS-B-CV

Power Regeneration Type

Power Supply Section

MDS-A-CR

Resistance Regeneration Type

Power Supply Section A

1. Power Regeneration Type Power Supply

1. Power Regeneration Type Power Supply

1.1 Outline

MDS-A/B-CV power supply outline

- (1) The converter section that was conventionally built in each servo drive unit and spindle drive unit has been integrated into one unit for common use.
- (2) The heat generation has been greatly reduced by using an IPM (Intelligent Power Module).
- (3) The 37.0kW unit has been newly added to the MDS-B Series.
Always install a contactor when using the 37.0kW unit.
- (4) With the MDS-B Series, an emergency stop signal input from an external source can be added, and the contactor directly shut off from the power supply.

1.2 Model configuration

Power supply unit model configuration

MDS-A-CV-

MDS-B-CV-

Power supply capacity class symbol

| Symbol | Capacity (kW) |
|--------|---------------|
| 37 | 3.7 |
| 55 | 5.5 |
| 75 | 7.5 |
| 110 | 11.0 |
| 150 | 15.0 |
| 185 | 18.5 |
| 220 | 22.0 |
| 260 | 26.0 |
| 300 | 30.0 |
| 370 | 37.0 |

* The 37.0kW is available only with the MDS-B Series.



WARNING

1. Do not omit the external contactor when using the MDS-B-CV-370. Failure to install it could lead to damage.

1. Power Regeneration Type Power Supply

1.3 List of specifications

| | Unit | Power supply unit model name | | | | | | | | | |
|-------------------------------------|--------|---|--------------------|--------------------|----------------------|----------------------|----------------------|----------------------|----------------------|----------------------|----------|
| | | A-CV-37 B-CV-37 | A-CV-55 B-CV-55 | A-CV-75 B-CV-75 | A-CV-110 B-CV-110 | A-CV-150 B-CV-150 | A-CV-185 B-CV-185 | A-CV-220 B-CV-220 | A-CV-260 B-CV-260 | A-CV-300 B-CV-300 | B-CV-370 |
| Output voltage | | 270V ~ 311V | | | | | | | | | |
| Main circuit method | | Converter with regenerative circuit (with IPM incorporated) | | | | | | | | | |
| Tolerable ambient temperature | °C | 0 ~ 55°C | | | | | | | | | |
| Tolerable ambient relative humidity | % | 90% or less (with no dew condensation) | | | | | | | | | |
| Storage temperature | °C | -15°C ~ 70°C | | | | | | | | | |
| Storage relative humidity | % | 90% or less (with no dew condensation) | | | | | | | | | |
| Atmosphere | | No toxic gas or dust | | | | | | | | | |
| Tolerable vibration | G | 0.5G | | | | | | | | | |
| Tolerable shock | G | 5G (acceleration) : When packaged | | | | | | | | | |
| Maximum heating value | W | 55 | 65 | 80 | 130 | 160 | 200 | 220 | 270 | 330 | 420 |
| Weight | kg | 5.0 | 5.0 | 5.0 | 8.5 | 10.5 | 10.5 | 12.5 | 12.5 | 12.5 | 12.5 |
| Capacity | kW | 3.7 | 5.5 | 7.5 | 11.0 | 15.0 | 18.5 | 22.0 | 26.0 | 30.0 | 37.0 |
| Tolerable power voltage | V | 200/200 ~ 230V ^{+10%} _{-15%} 50/60Hz ±3Hz | | | | | | | | | |
| Noise | dB (A) | Less than 55dB | | | | | | | | | |

1. Power Regeneration Type Power Supply

1.4 Hardware setting

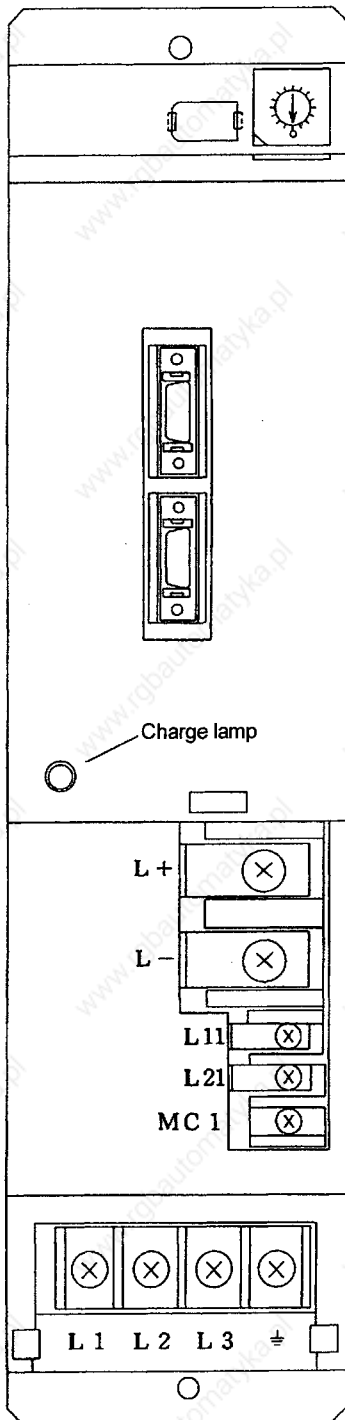

Set the rotary switch (SW1) as shown below.

| SW1 setting | A-CV usage state | B-CV usage state | |
|-------------|---|---|-------------------------|
| 0 | During operation with contactor (deposits are detected) | During operation with contactor (deposits are detected) | External emergency stop |
| 1 | During operation with no contactor | During operation with no contactor | When not used |
| 2 | Setting prohibited | Setting prohibited | |
| 3 | | | |
| 4 | | During operation with contactor (deposits are detected) | External emergency stop |
| 5 | | During operation with no contactor | When used |
| 6 | | Setting prohibited | |
| 7 | | | |
| 8 | Setting prohibited | | |
| 9 | | | |
| 10 | | | |
| 11 | | | |
| 12 | | | |
| 13 | | | |
| 14 | | | |
| 15 | | | |

By opening the lid (to right of LED status display window) on the upper front of the power supply unit and turning the rotary switch, the use of the externally installed contactor can be set.

The example on the left shows the settings with the contactor. Note that the external contactor cannot be omitted for the MDS-B-CV-370. Therefore, the "1" and "5" settings of SW1 are prohibited.

1. Power Regeneration Type Power Supply

1.5 Status display

|  WARNING |
|--|
| 1. Do not touch the switches with wet hands. Failure to observe this could lead to electric shocks. |
| 2. Do not operate the unit with the front cover removed. The high voltage terminals and charged sections will be exposed, and can cause electric shocks. |
| 3. Do not open the front cover while the power is ON or during operation. Failure to observe this could lead to electric shocks. |

|  CAUTION |
|--|
| 1. Check and adjust each parameter before starting operation. Failure to do so could lead to unforeseen operation of the machine. |
| 2. The servo amplifier's radiating fins, regenerative resistor and servomotor, etc., will be hot while operating and for some time after the power is turned OFF. Thus, do not touch these parts. Failure to observe this could lead to burns. |

1.5.1 7-segment LED display

- 1) Power ON

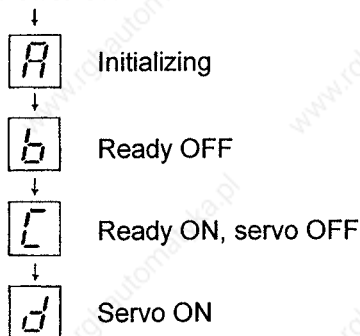

- 2) Display during alarm (example shows overvoltage alarm)

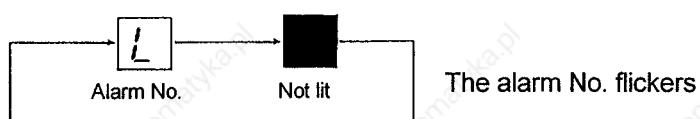

- 3) Display during warning (example shows instantaneous stop warning)

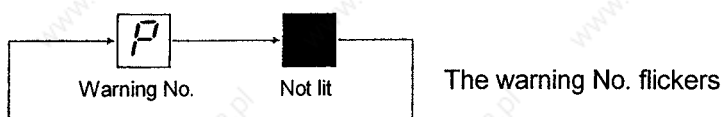

- 4) Watch dog alarm



1.5.2 Charge lamp

This lamp lights when the rectifying voltage between P and N is charged over a set level. Always confirm that the charge lamp is not lit, and using a tester, confirm that the voltage has been discharged before starting maintenance work such as replacing the unit.

1. Power Regeneration Type Power Supply

1.6 List of alarms and warnings

| |
|--|
| ⚠ CAUTION |
| When an alarm occurs, remove the cause of the alarm, confirm that an operation signal is not being input, and secure the safety. Then reset the alarm to resume operation. |

When an alarm occurs in the servo amplifier, the base will be shut off and the motor will coast to a stop. Turn the power OFF with an external sequence. (Refer to 1.9 Main circuit connection.)
When resetting the alarm, remove the cause, and then turn the power ON.

(1) Alarms

[Alarm No.] Alarm No. displayed on drive unit connected with power supply unit
 [LED display] LED display on power supply unit
 [Release] AR : Release by turning power supply on again
 PR : Release by turning the NC power supply on again
 NR : Release with the NC RESET key

| Alarm No. | LED display | Name | Meaning | Release |
|--------------|-------------|---|---|----------------|
| 61 [61] | 1 | Power module overcurrent | An overcurrent (Ic) was detected in the power module (IPM). | PR |
| 63 [63] | 3 | Auxiliary regeneration error | The auxiliary circuit transistor stays on. | PR |
| 65 [65] | 5 | Rush relay error | The rush resistance short circuit relay does not turn on. | PR |
| 67 [67] | 7 | Open phase | One of the input power phases (R,S,T) is open. | PR |
| 68 [68] | 8 | Watch dog | The power supply software process did not complete within the set time. | AR |
| 69 [69] | 9 | Ground fault | There is a ground fault in the motor. This is detected only at READY ON. | PR |
| 6A [6A] | A | External contactor melt | The externally installed contactor turned on even during ready OFF. | PR |
| 6B [6B] | b | Rush relay melt | The rush resistance short circuit relay is still on. | PR |
| 6C [6C] | C | Main circuit error | The main circuit capacitor charging operation is not normal. | PR |
| 6E [6E] | E | Memory error | An error occurred in the memory circuit. | AR |
| 6F [6F] | F | AD converter error Power supply error | An AD converter error or power supply error was detected. | AR |
| 71 [71] | H | Instantaneous stop External emergency stop | The external contactor turned off even during ready ON. An instantaneous power stop occurred for 55ms or more. | NR |
| *1 73 [73] | J | Over-regeneration | The regeneration performance limit of the power supply was exceeded. | PR (Note 1) |
| 75 [75] | L | Overvoltage | The voltage between L+ and L- exceeded 410V. | NR |
| *1 76 [76] | n | External emergency stop setting error | The rotary switch setting and parameter (PTYP) setting do not match. | AR |
| 77 [77] | n | Power module overheat | Overheating of the power module (IPM) was detected. | AR |

1. Power Regeneration Type Power Supply

Note 1) With alarm "73", to prevent immediately resumption of operation from the over-regeneration state, the alarm cannot be released unless the control power (L11, L12) continuity state has continued for 15 minutes or more after the alarm has occurred. The alarm cannot be released even if the NC power or control power is turned ON immediately after the alarm occurs. If the power is turned ON immediately after the alarm occurred, wait 15 minutes or more in the continuity state, and then turn the power ON again.

(2) Warning

| Alarm No. | LED display | Name | Meaning |
|------------|-------------|---------------------------------------|--|
| E8 (EB) | o (o) | Auxiliary regeneration frequency over | The regeneration frequently exceeds the power supply regeneration capacity limit. |
| E9 (E9) | P (P) | Instantaneous stop warning | An instantaneous power stop occurred for 25ms or more. (As the main circuit voltage has not dropped, an alarm has not occurred.) |
| *1 EA (EA) | q (q) | External emergency stop input | The external emergency stop input signal was input. (24V is not applied on the CN23 connector.) |
| EB (Eb) | r (r) | Over-regeneration warning | 80% of the over-regeneration alarm level was reached. |

*1) These alarms and warning have been added from the MDS-B Series.

1. Power Regeneration Type Power Supply

1.7 Explanation of connectors and terminal block

The CN23 external emergency stop connection connector has been added to the MDS-B Series.

| | | Name | Application | Remarks |
|----------------|-----|---------------------|---|-------------------|
| Connector | | CN4 CN9 CN23 | For connection of servo and spindle amplifier (CH1) For connection of servo and spindle amplifier (CH2) For connection of the external emergency stop | Added with MDS-B. |
| Terminal block | TE2 | L+ L- | Converter voltage output (+) Converter voltage output (-) | |
| | TE3 | L11 L12 MC1 | } 200VAC single phase input For externally installed contactor relay control | |
| | TE1 | L1 L2 L3 ⊕ | } 3-phase input power 200/220VAC Grounding | |

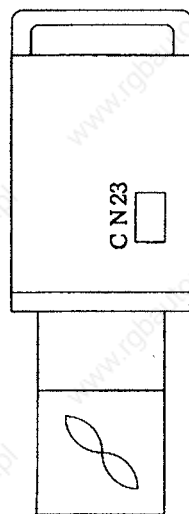

View A

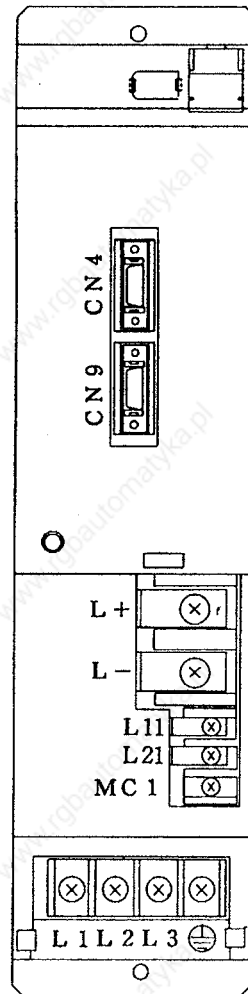

A

1.8 Functions added with MDS-B Series (Power supply external emergency stop function)

(1) Outline

An independent emergency stop signal from an external source has been added in addition to the emergency stop signal from the NC bus line, allowing double protection. When this function is not used, the specifications are the same as the A Series.

(2) Details of detection

1) Setting

When using the external emergency stop, the protection setting must be validated with the rotary switch on the front of the MDS-B-CV and the parameter (PTYP) of the connected drive unit.

Rotary switch : External contact valid Set to 4 

External contact invalid..... Set to 5 

Parameter (PTYP) : Add 0040 to the currently set value.

(Example)

| Current | Setting value |
|---------|---------------|
| 0008 | 0048 |
| 0030 | 0070 |

Note) If either of the settings are not made, an "external emergency stop setting error" will occur.

2) Detection details

If the external emergency stop input is detected continuously for 200ms or more, this function will start.

If the contactor OFF command from the NC is not received within 30 seconds after the external emergency stop input is detected, the CV itself will turn the contactor OFF.

3) Alarm (Warning) list

| CV display (flicker) | Connected amplifier display | Alarm/warning details |
|----------------------|-----------------------------|---|
| m | 76 | External emergency stop setting error |
| q | EA | Emergency stop state from NC when external emergency stop input is input |
| q | 6F | When emergency stop from NC is not applied even when the external emergency stop is input |

1. Power Regeneration Type Power Supply

(3) Connection

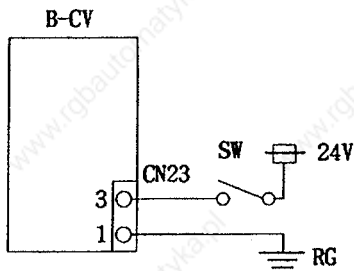
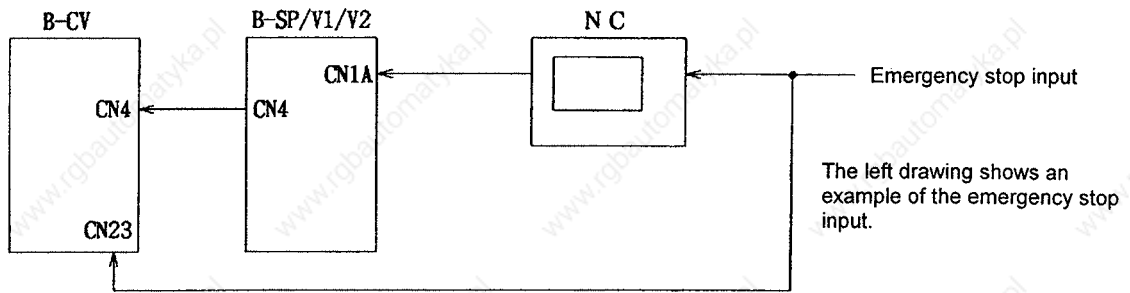

- * The current that flows when the contact is ON is 15mA. Make sure not to mistake the polarity. (This function will not work if the 24VDC polarity is mistaken.)
- * The emergency stop operation is applied when the switch in the diagram opens.

(4) Connector name

| Part No. | Name | Type | Maker |
|----------|-----------|------------|-----------|
| 101 | Connector | 2-178288-3 | Japan AMP |
| 102 | Contact | 1-175218-2 | Japan AMP |

Wire size: 0.5 to 1.25SQ

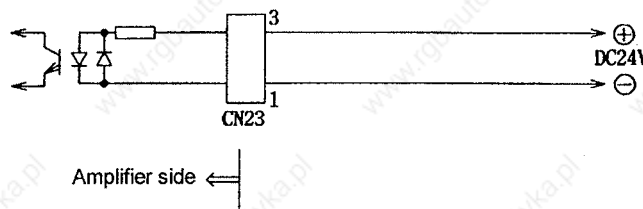
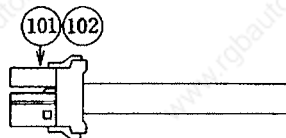

1. Power Regeneration Type Power Supply

1.9 Main circuit connection



WARNING

Ground the servo amplifier and servomotor with Class 3 grounding or higher.



CAUTION

1. Correctly connect the servo amplifier and servomotor power supply phases (U, V, W). The servomotor will operate abnormally.
2. Do not apply a voltage other than that specified on each terminal. Failure to observe this could lead to breakage or trouble.

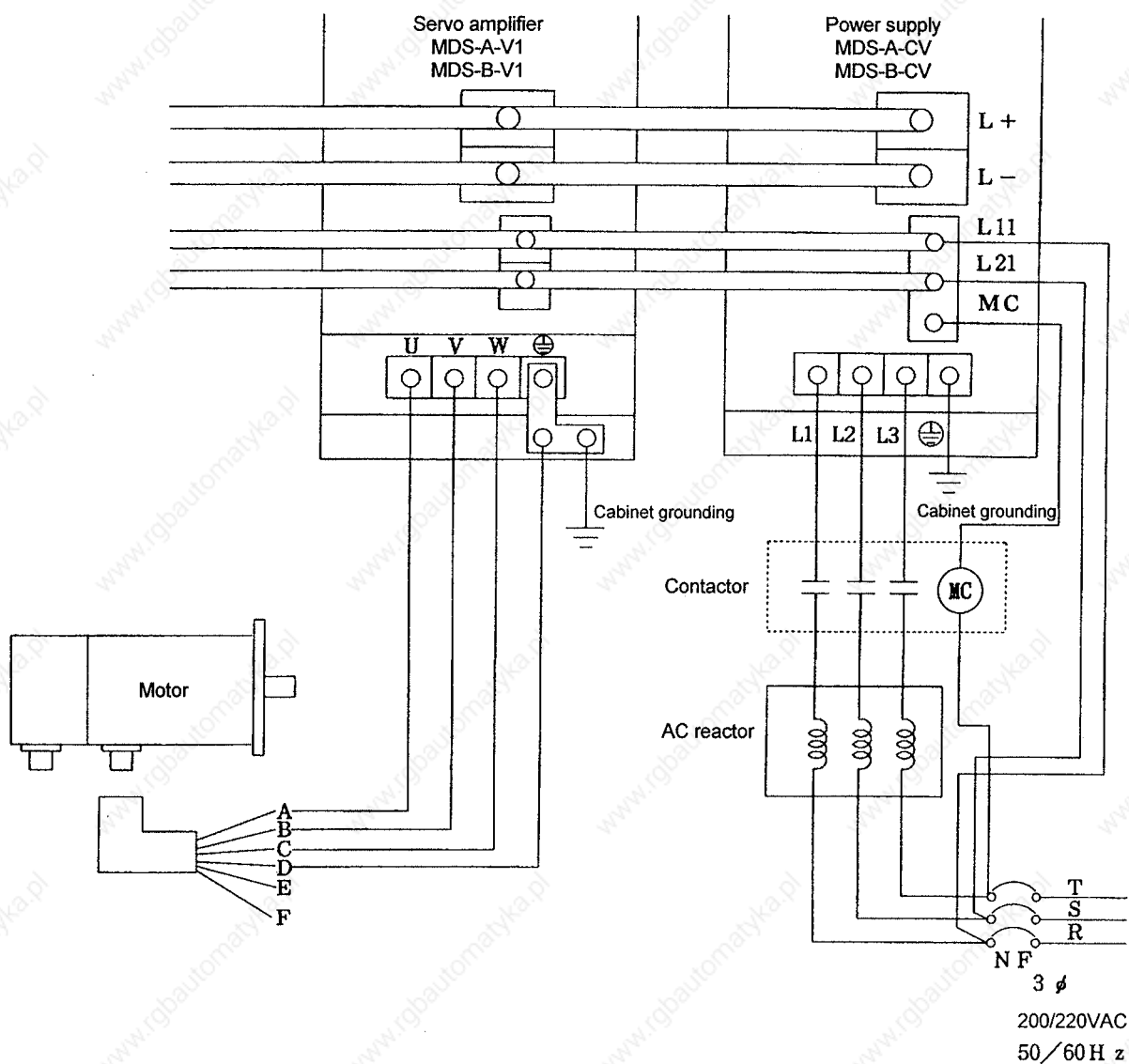

1. Power Regeneration Type Power Supply

- * A grounding bar is enclosed with each unit manufactured after April 1995. Use separate wiring as shown below so that the grounding is not commonly tightened.

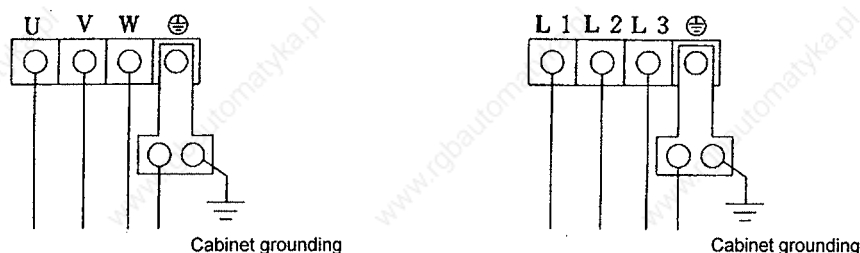

Precautions for connections

- (1) The wires and crimp terminals will differ according to the capacity.
(Refer to section 8.3 in the Chapter I Servo/spindle system configuration.)
- (2) A 200V class power supply is used.
The main circuit section does not have a transformer so always ground it.
- (3) The phase order of the power supply terminals L1, L2, L3 is random.
- (4) Refer to Section 8.3 in the Servo/Spindle system configuration for the selection of the contactor, AC reactor and non-fuse breaker connected to the power supply.
- (5) The specified power supply must be connected to the amplifier power supply terminals (L1, L2 and L3). Use a transformer when the power supply is not as specified.
- (6) The power supply wires (R, S, T) must not be connected to the motor output terminals (U, V, W).
- (7) The output terminal (U, V, W) and motor terminal (A, B, C) phases must match.
- (8) Do not directly apply commercial power on the motor.
- (9) Check once again that the wires are connected correctly as indicated in the connection diagram.

2. Resistance Regeneration Type Power Supply

2.1 Outline

The following items differ from the power supply unit (MDS-A/B-CV).
Refer to 2.10 Resistance regeneration converter wiring diagram for details.

- (1) Input the following into connector CN22.
 - Control power supply 24V (current capacity 500mA)
 - Resistor unit's thermal signal(Prepare 24VDC for control, and input.)
- (2) Make sure that the control 24VDC power supply described in (1) above, is turned ON before the servo and spindle drives and the NC.
- (3) The conventional control power supply 200VAC input is not required.
(The resistor unit R1 and conductor excitation signal are wired to the terminal block where the conventional 200VAC was input.)
- (4) The resistance regeneration converter unit series does not have the external heat radiating fins.
(These are installed inside, so the conventional square hole for sealing is not required.)
- (5) A standalone regenerative resistor unit is required.
- (6) The power is not regenerated, so the AC reactor is not required.

2.2 Model configuration

Resistance regeneration converter unit model configuration

MDS-A-CR-

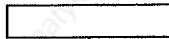

Resistance regeneration converter capacity class symbol

| Symbol | Capacity (kW) |
|--------|---------------|
| 10 | 1.0 |
| 15 | 1.5 |
| 22 | 2.2 |
| 37 | 3.7 |
| 55 | 5.5 |
| 75 | 7.5 |
| 90 | 9.0 |

2. Resistance Regeneration Type Power Supply

2.3 List of specifications

| | | Resistance regeneration converter unit model name | | | | | | | |
|-------------------------------------|----------------------|---|--|---------|---------|---------|---------|---------|---------|
| | | Unit | A-CR-10 | A-CR-15 | A-CR-22 | A-CR-37 | A-CR-55 | A-CR-75 | A-CR-90 |
| Output voltage | | | 270V | | | | | | |
| Main circuit method | | | Converter with resistance regeneration circuit | | | | | | |
| Tolerable ambient temperature | | °C | 0 ~ 55°C | | | | | | |
| Tolerable ambient relative humidity | | % | 90% or less (with no dew condensation) | | | | | | |
| Storage temperature | | °C | -15°C ~ 70°C | | | | | | |
| Storage relative humidity | | % | 90% or less | | | | | | |
| Atmosphere | | | No toxic gas or dust | | | | | | |
| Tolerable vibration | | G | 0.5G | | | | | | |
| Tolerable shock | | G | 5G (acceleration) : When packaged | | | | | | |
| Maximum heating value | | W | 21W | 24W | 33W | 43W | 52W | 62W | 80W |
| Weight | | kg | 2.0 | 2.0 | 2.0 | 2.0 | 2.0 | 2.5 | 2.5 |
| Capacity | | kW | 1.0 | 1.5 | 2.2 | 3.7 | 5.5 | 7.5 | 9.0 |
| Tolerable power voltage | RST | V | 200/200 ~ 230VAC $\pm 10\%$ -10% 50/60Hz $\pm 3\text{Hz}$ | | | | | | |
| | Control power supply | V | 24VDC $\pm 15\%$ | | | | | | |

2.4 Capacity selection

2.4.1 Regenerative resistor unit capacity selection

(1) List of regenerative resistor units

The regenerative resistor units (external installation) compatible with the resistance regeneration converter units are as follow.

| No. | Type | Tolerable regenerative capacity (WR) | Outline drawing | Thermal signal | FAN |
|--------|-------------------|--------------------------------------|-----------------|----------------|--------------|
| Note 1 | ① GZG200W26OHMJ | 80W | Fig. 1 | Not provided | Not provided |
| | ② GZG300W13OHMJ×2 | 150W | Fig. 1 | Not provided | Not provided |
| | ③ MR-RB30 | 300W | Fig. 2 | Provided | Not provided |
| Note 2 | ④ MR-RB50 | 500W | Fig. 3 | Provided | Not provided |
| | ⑤ GZG200W20OHMJ×3 | 350W | Fig. 1 | Not provided | Not provided |
| Note 2 | ⑥ GZG300W20OHMJ×3 | 500W | Fig. 1 | Not provided | Not provided |
| | ⑦ R-UNIT-1 | 700W | Fig. 4 | Provided | Provided |
| | ⑧ R-UNIT-2 | 700W | Fig. 4 | Provided | Provided |
| | ⑨ R-UNIT-3 | 2.1Kw | Fig. 5 | Provided | Provided |

Refer to section 2.11 Regenerative resistor unit outline drawing.

Note 1. This is a 2-unit serial type.

Note 2. This is a 3-unit parallel type.

2. Resistance Regeneration Type Power Supply

(2) Selection of the regenerative resistor unit

Select the corresponding regenerative resistor unit from the following table.

| Regenerative resistor converter capacity | Spindle motor capacity (kW) | Servomotor capacity (for 2 or more axes) | Servomotor capacity (for 1 axis) (kW) | Corresponding regenerative resistor unit No. |
|--|-----------------------------|--|---------------------------------------|--|
| 9kW (A-CR-90) | 7.5 | 2.8kW or less | 2.0 | ⑧, ⑨ |
| | 5.5 | 5.7kW or less | 3.5 | ⑧, ⑨ |
| | 3.7 | 8.2kW or less | 4.5 | ⑤, ⑥ |
| | 2.2 | 10.4kW or less | 7.0 | ⑤, ⑥ |
| | 1.5 | 11.4kW or less | 9.0 | ⑤, ⑥ |
| | – | 13.5kW or less | 9.0 | ⑤, ⑥ |
| 7.5kW (A-CR-75) | 7.5 | 0.7kW or less | 0.5 | ⑧, ⑨ |
| | 5.5 | 3.5kW or less | 2.0 | ⑧, ⑨ |
| | 3.7 | 6.1kW or less | 3.5 | ⑤, ⑥ |
| | 2.2 | 8.2kW or less | 4.5 | ⑤, ⑥ |
| | 1.5 | 9.2kW or less | 4.5 | ⑤, ⑥ |
| | – | 10.6kW or less | 7.0 | ⑤, ⑥ |
| 5.5kW (A-CR-55) | 5.5 | 0.7kW or less | 0.5 | ⑧, ⑨ |
| | 3.7 | 3.2kW or less | 2.0 | ⑧, ⑨ |
| | 2.2 | 5.4kW or less | 3.5 | ③, ④ |
| | 1.5 | 6.4kW or less | 4.5 | ③, ④ |
| | 0.75 | 7.5kW or less | 4.5 | ③, ④ |
| | – | 8.5kW or less | 4.5 | ③, ④ |
| 3.7kW (A-CR-37) | 3.7 | 0.7kW or less | 0.5 | ⑧, ⑨ |
| | 2.2 | 2.8kW or less | 2.0 | ⑧, ⑨ |
| | 1.5 | 3.8kW or less | 2.0 | ③, ④ |
| | 0.75 | 4.9kW or less | 3.5 | ③, ④ |
| | – | 6.0kW or less | 3.5 | ③, ④ |
| 2.2kW (A-CR-22) | 2.2 | 0kW or less | 0 | ⑦ |
| | 1.5 | 1.0kW or less | 0.5 | ⑦ |
| | 0.75 | 2.0kW or less | 1.0 | ⑦ |
| | 0.4 | 2.5kW or less | 1.0 | ② |
| | – | 3.1kW or less | 2.0 | ② |
| 1.5kW (A-CR-15) | 1.5 | 0kW or less | 0 | ⑦ |
| | 0.75 | 1.0kW or less | 0.5 | ② |
| | 0.4 | 1.5kW or less | 1.0 | ② |
| | – | 2.1kW or less | 1.0 | ① |
| 1.0kW (A-CR-10) | 0.75 | 0.3kW or less | 0.1 | ② |
| | 0.4 | 0.8kW or less | 0.5 | ② |
| | – | 1.4kW or less | 1.0 | ① |

Note 1. Confirm that the regenerative energy under the working conditions is within the tolerable regeneration capacity (Refer to regenerative resistor unit list) of the regenerative resistor unit. (The following expression must be satisfied.)

$$WR \geq \sum_{i=1}^m \frac{ni}{120} \left\{ \frac{Ji}{100000} \left[\frac{2\pi Ni}{60} \right]^2 + Wi \cdot g \cdot \frac{hi}{1000} \cdot 0.8 \right\}$$

WR : Tolerable regeneration capacity of resistor unit [W]

m : No. of axes

ni : i axis acceleration/deceleration frequency (repeated positioning frequency) [times/min]

Ji : i axis motor shaft conversion inertia [$\times 10^{-4}$ kg·m²]

Ji = JLi + JMi

JLi : Motor shaft conversion load inertia [$\times 10^{-4}$ kg·m²]

JMi : Working motor rotor inertia [$\times 10^{-4}$ kg·m²]

Ni : i axis motor speed [rpm]

g : 9.80665 [m/s²]

Wi : i axis unbalance weight [kg]

hi : Vertical shaft full stroke (i axis) [mm]

Note 2. One regenerative resistor must be installed for each resistance regeneration converter unit. Conversely, multiple regenerative resistance units cannot be installed on one resistance regeneration converter unit.

2. Resistance Regeneration Type Power Supply

External regenerative resistor and power supply (A-CR) compatibility table

| External regenerative resistor type | rtyp | CR-10 | CR-15 | CR-22 | CR-37 | CR-55 | CR-75 | CR-90 |
|-------------------------------------|------|-------|-------|-------|-------|-------|-------|-------|
| GZG200W260HMJ | 01 | ○ | ○ | ○ | ○ | ○ | ○ | ○ |
| GZG300W130HMJ × 2 | 02 | ○ | ○ | ○ | ○ | ○ | ○ | ○ |
| MR-RB30 | 03 | × | × | × | ○ | ○ | ○ | ○ |
| MR-RB50 | 04 | × | × | × | ○ | ○ | ○ | ○ |
| GZG200W200HMJ × 3 | 05 | × | × | × | × | × | ○ | ○ |
| GZG300W200HMJ × 3 | 06 | × | × | × | × | × | ○ | ○ |
| R-UNIT-1 | 07 | ○ | ○ | ○ | ○ | ○ | ○ | ○ |
| R-UNIT-2 | 08 | × | × | × | ○ | ○ | ○ | ○ |
| R-UNIT-3 | 09 | × | × | × | ○ | ○ | ○ | ○ |

2.6 Status display

| |
|---|
|  WARNING |
| <ol style="list-style-type: none"> 1. Do not touch the switches with wet hands. Failure to observe this could lead to electric shocks. 2. Do not operate the unit with the front cover removed. The high voltage terminals and charged sections will be exposed, and can cause electric shocks. 3. Do not open the front cover while the power is ON or during operation. Failure to observe this could lead to electric shocks. |

| |
|---|
|  CAUTION |
| <ol style="list-style-type: none"> 1. Check and adjust each parameter before starting operation. Failure to do so could lead to unforeseen operation of the machine. 2. The servo amplifier's radiating fins, regenerative resistor and servomotor, etc., will be hot while operating and for some time after the power is turned OFF. Thus, do not touch these parts. Failure to observe this could lead to fires. |

(1) 7-segment LED display

(a) Power ON

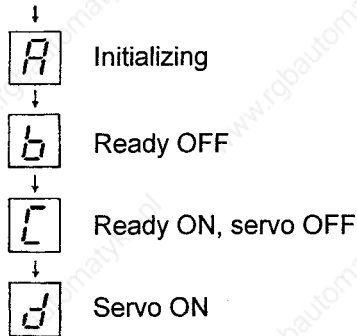

(b) Display during alarm (example shows overvoltage alarm)



(c) Display during warning (example shows instantaneous stop warning)

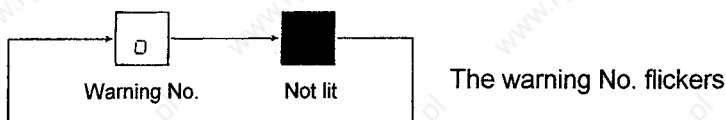

(d) Watch dog alarm



(2) Charge lamp

This lamp lights when the rectifying voltage between P and N is charged over a set level. Always confirm that the charge lamp is not lit before starting maintenance such as replacing the unit.

2. Resistance Regeneration Type Power Supply

2.7 List of alarms and warnings

| |
|--|
|  CAUTION |
| When an alarm occurs, remove the cause of the alarm, confirm that an operation signal is not being input, and secure the safety. Then reset the alarm to resume operation. |

When an alarm occurs in the servo amplifier, the base will be shut off and the motor will coast to a stop. Turn the power OFF with an external sequence. (Refer to 5.7 Main circuit connection.)
When resetting the alarm, remove the cause, and then turn the power ON.

IMPORTANT

When a regeneration alarm (AL63) occurs, if operation is repeated by turning the power OFF and ON, trouble could occur due to heating of the external regenerative resistor. Exercise caution in this case.

(1) Alarms

| | |
|---------------|--|
| [Alarm No.] | Alarm No. displayed on drive unit connected with resistance regeneration converter unit |
| [LED display] | LED display on resistance regeneration converter unit |
| [Release] | AR : Releases by turning the resistance regeneration converter unit power on again PR : Release by turning the NC power supply on again NR : Release with the NC RESET key |

| Alarm No. | LED display | Name | Meaning | Release |
|-----------|-------------|--------------------------------|---|---------|
| 60 | 0 | Instantaneous stop | The 24VDC dropped. | PR |
| 63 | 3 | Regeneration error | The regeneration transistor turned ON while the regeneration command was OFF. | PR |
| 65 | 5 | Rush relay error | The rush relay does not turn on, and chattering occurs. | PR |
| 68 | 8 | Watch dog | CPU runaway | AR |
| 69 | 9 | Ground fault | Driver UVW ground fault | PR |
| 6B | b | Rush relay melt | The rush relay did not turn OFF | PR |
| 6C | c | Main circuit error | The bus is short circuited, the charge to the main circuit is abnormal | PR |
| 6D | d | Parameter error | The regenerative resistor setting is not adequate | PR |
| 6E | e | Memory error | The memory cannot be read/written correctly | AR |
| 73 | j | Over-generation | The regeneration load was exceeded | PR |
| 74 | t | Regeneration resistor overheat | The regenerative resistor thermal functioned | PR |
| 75 | L | Overvoltage | The bus voltage rose. | NR |
| 77 | n | PCB overheat | Overheating of thermal in amplifier | PR |

(2) Warning

| | | | | |
|----|---|---------------------------|--|--|
| E8 | o | Over-regeneration warning | 80% of the over-regeneration alarm level | |
|----|---|---------------------------|--|--|

2. Resistance Regeneration Type Power Supply

2.8 Resistance regeneration converter unit outline drawing

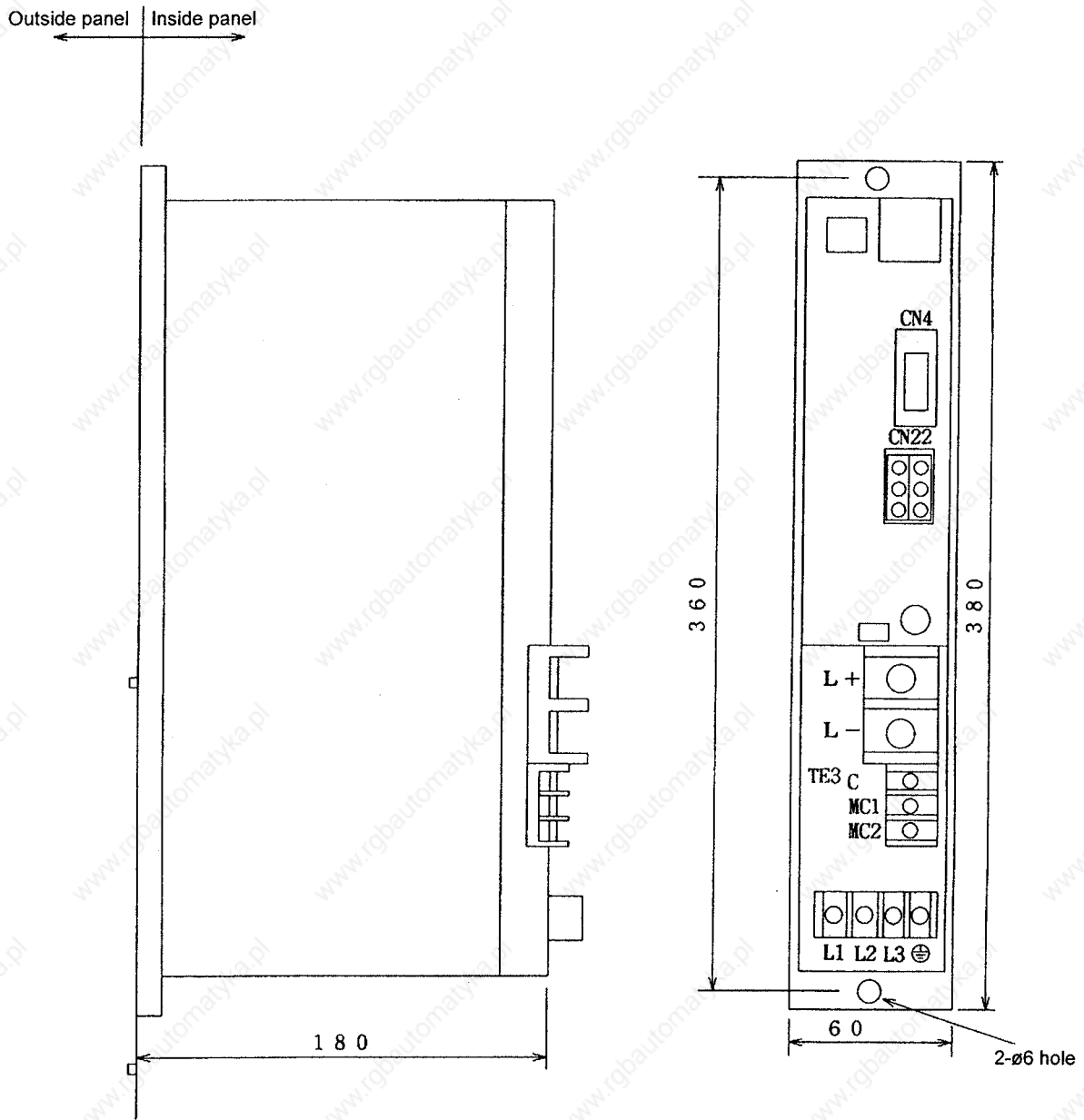

2. Resistance Regeneration Type Power Supply

2.9 Connection of each unit

CAUTION
Do not apply a voltage other than that specified on each terminal. Failure to observe this could lead to breakage or trouble.

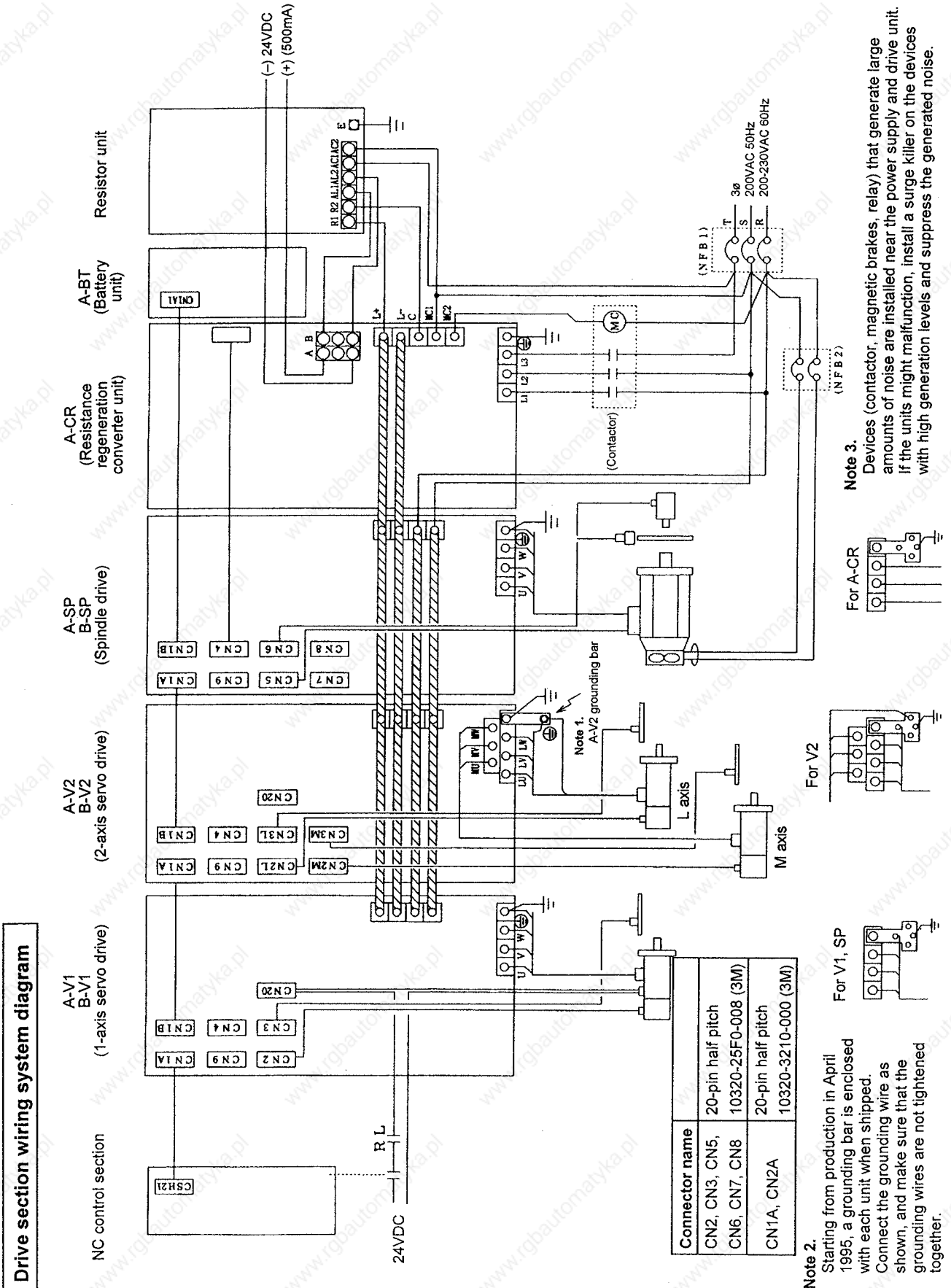

2. Resistance Regeneration Type Power Supply

2.10 Resistance regeneration converter wiring diagram

(1) For GZG type resistor unit

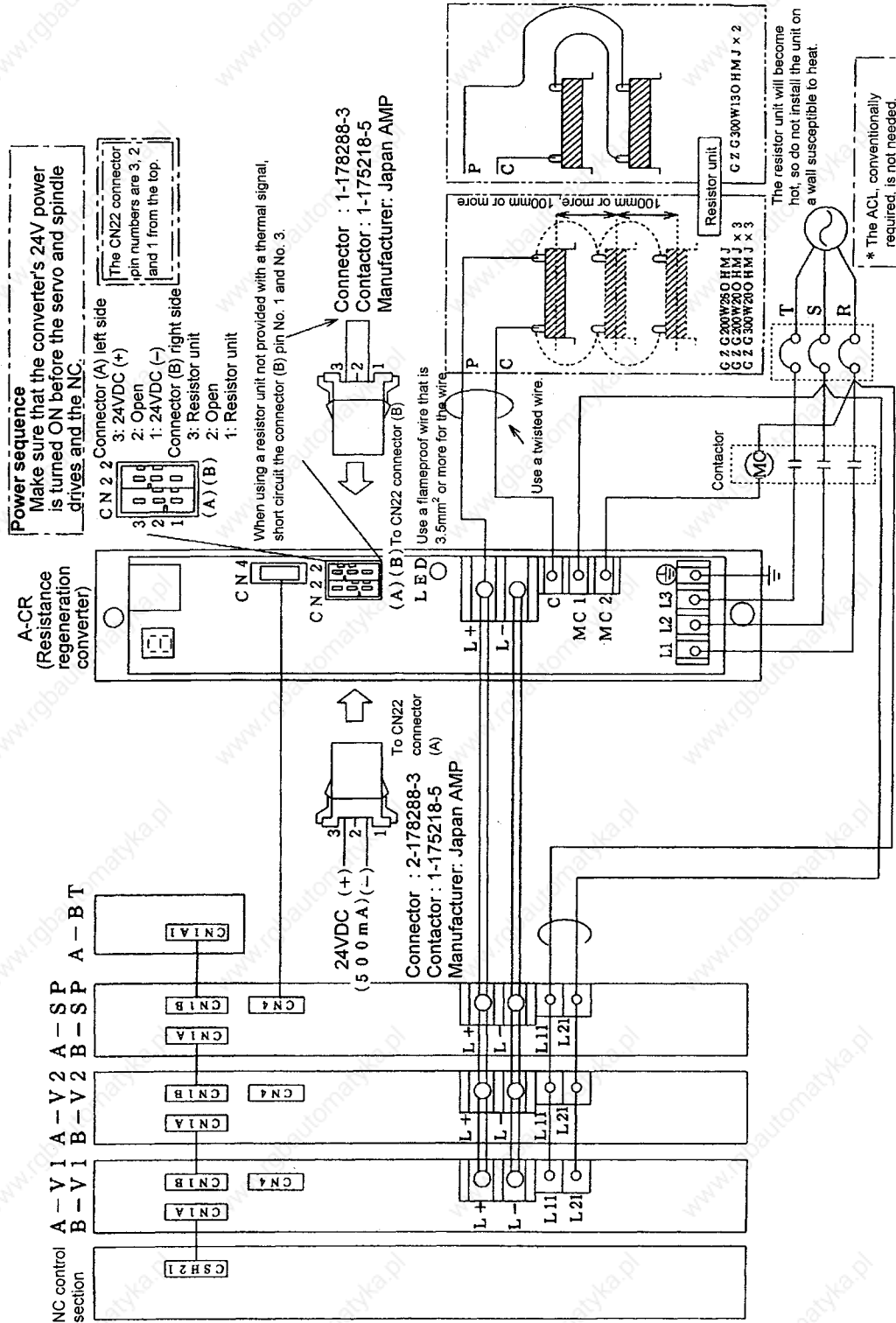

2. Resistance Regeneration Type Power Supply

(2) For MR-RB type resistor unit

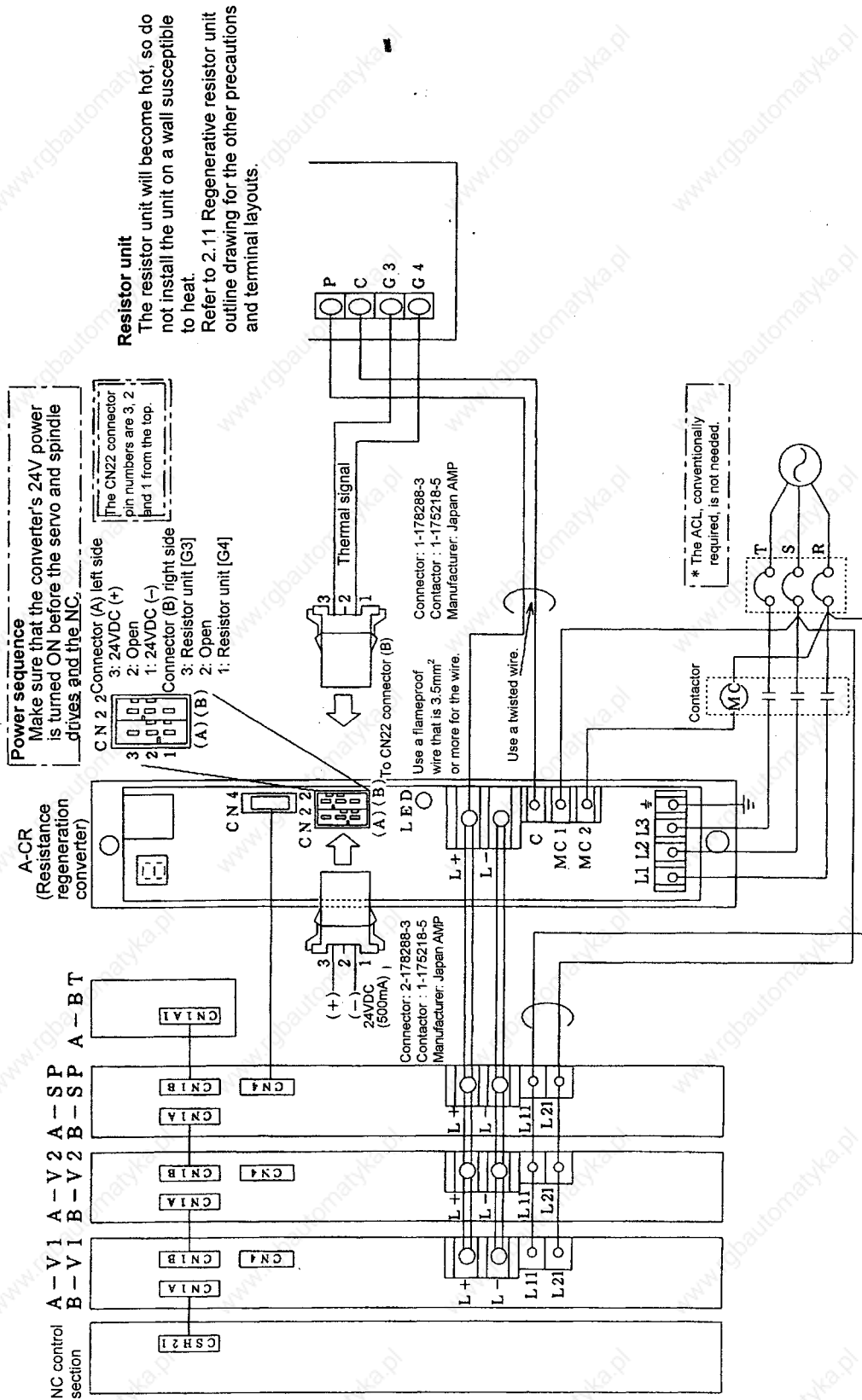

2. Resistance Regeneration Type Power Supply

(3) For R-UNIT type resistor unit

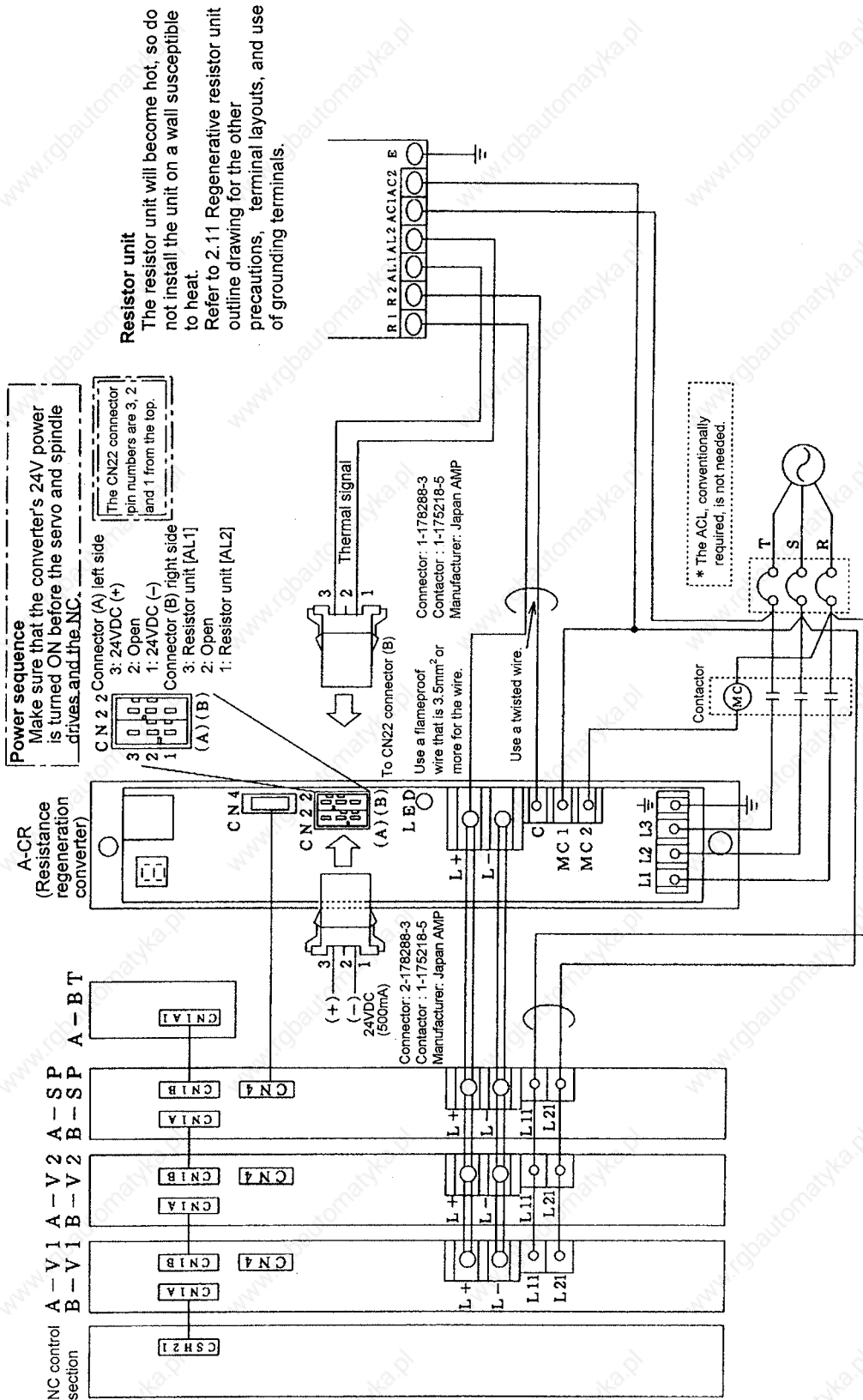

2. Resistance Regeneration Type Power Supply

Fig. 3

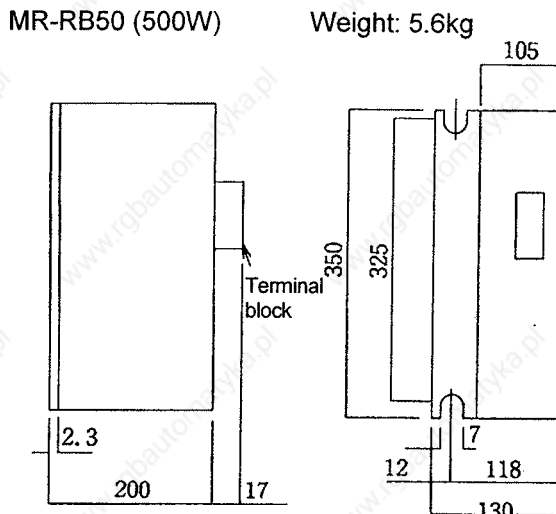

Note) Forcibly cool with a cooling fan (approx. 3.5m/s or more, □92).

Fig. 4

R-UNIT-1, R-UNIT-2

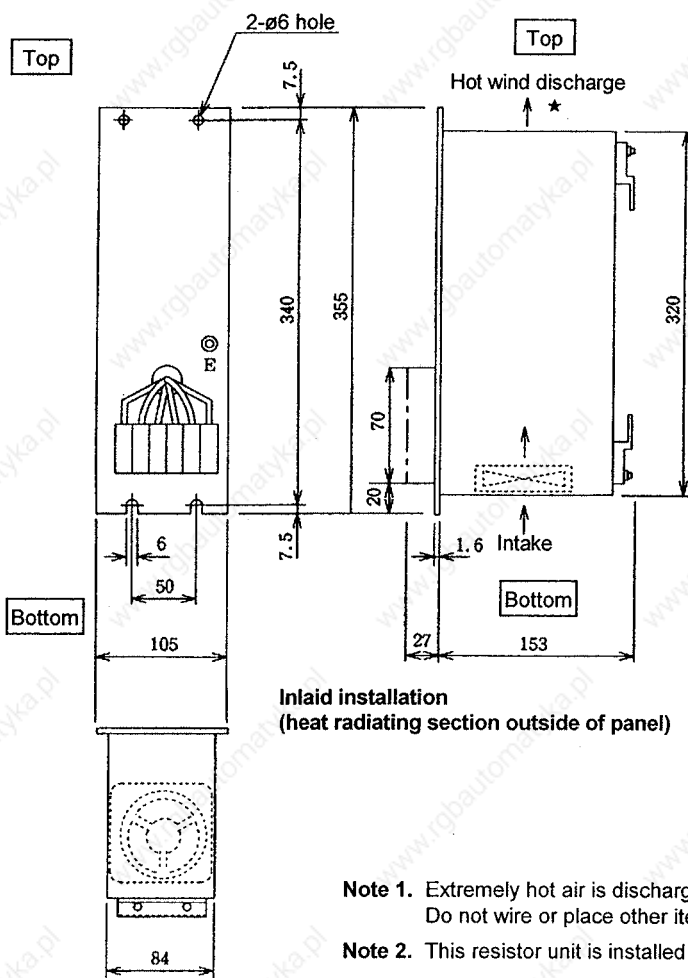

Terminal layout

| | | | | | |
|----|----|-----|-----|-----|-----|
| R1 | R2 | AL1 | AL2 | AC1 | AC2 |
|----|----|-----|-----|-----|-----|

Terminal screw size
M4 x 0.7 screw

Applicable crimp terminal
Bare round type up to 5.5-4

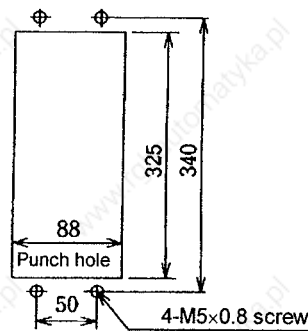

Installation hole dimensions for inlaid installation

Note 1. Extremely hot air is discharged from the sections marked with a ★.
Do not wire or place other items here.

Note 2. This resistor unit is installed with the **Top** up and the **Bottom** down.

Note 3. Touching the resistor unit while it is hot could lead to burns.
Install a protective cover, or consider the installation position so that workers will not touch the unit.

2. Resistance Regeneration Type Power Supply

Fig. 5
R-UNIT-3

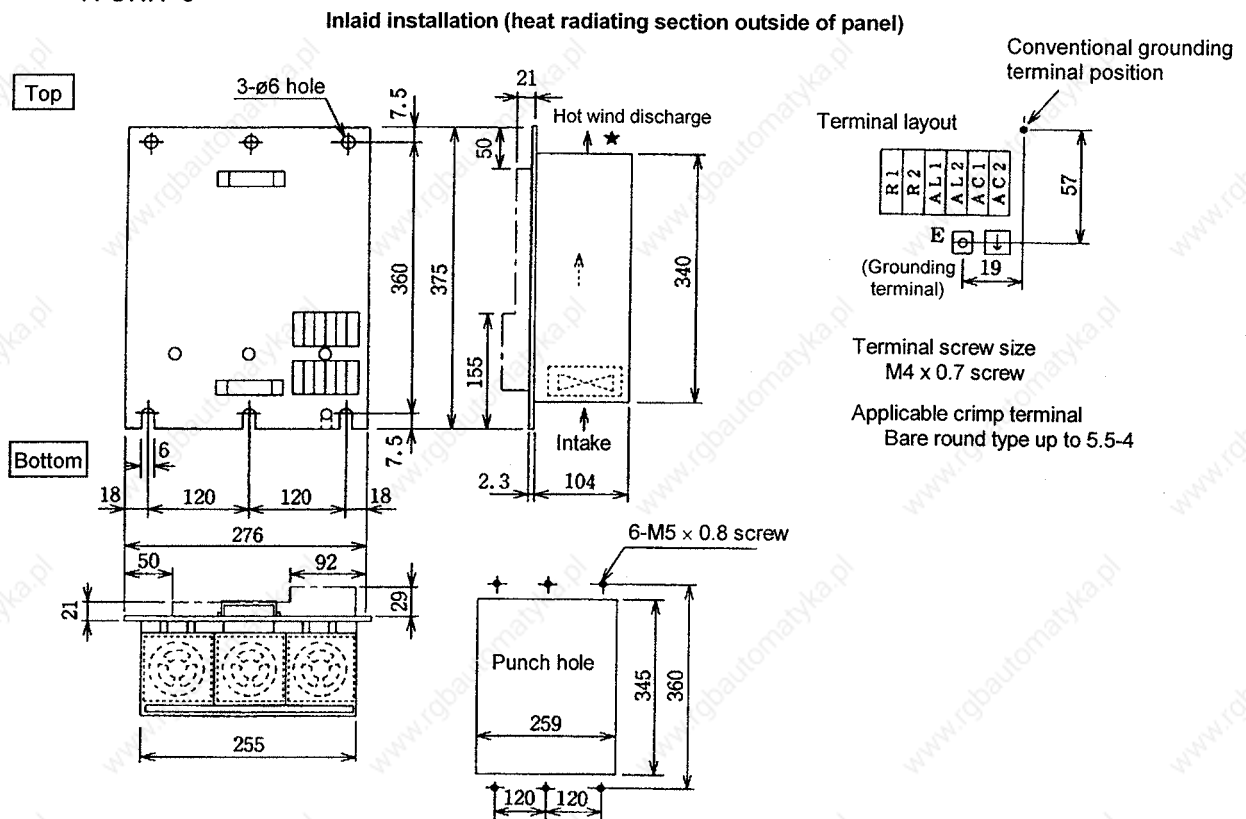

Note 1. The ventilation area is approx. 100×120 .

Note 2. Attach packing at the position where the flange is installed.

Note 3. Extremely hot air is discharged from the sections marked with a ★.
Do not wire or place other items here.

Note 4. This resistor unit is installed with the **Top** up and the **Bottom** down.

Note 5. Touching the resistor unit while it is hot could lead to burns.
Install a protective cover, or consider the installation position so that workers will not touch the unit.

III. MDS-A-Vx, MDS-B-Vx Servo System Section

1. Outline

Outline of MDS servo system

1. The converter that was conventionally built into the MR-S servo drive unit has been congregated in the power supply unit and standardized with the drive unit for other axes. This allows a great reduction in size and weight.
2. By using a high-speed CPU and 100,000 pulse/rev. (max. 3000rpm) submicron detector as a standard, high-speed and accurate machining is possible.
3. By using the same feedback interface for the detector, an interface PCB does not need to be prepared for each specification (scale feed back, submicron, absolute position detection, etc.).
4. The following models have been added to the line up with the changes from the MDS-A-Vx Series to the MDS-B-Vx Series.
The 110/150 servo drive unit has been added to MDS-B-V1.
The 4535/4520 servo drive unit has been added to MDS-B-V2.

2. Motor

2.1 Outline

Outline of motor for MDS-A-Vx, MDS-B-Vx servo system

- (1) A high precision 100,000 pulse /rev. detector has been incorporated as a standard.
- (2) The differences with the conventional motors for the M300 series are as follow:
 - a. All models have an oil seal.
 - b. The wiring for the thermal protector has been placed inside the detector's cannon plug.
 - c. Conventionally, the terminal box type could be handled even with the standard cannon connector method motor by using special specifications, but this is not possible with the MDS-A/B-Vx series.

2. Motor

2.2 Model configuration

HA motor model configuration

HA -

- D5 : IP65
 D7 : IP67
 No symbol : IP54 (Note that the 11K2/15k2 is equivalent to IP44.)
- R : HA303, HA700, HA703, HA900 sealed type terminal box
 No symbol : Other
- S : Shaft end with oil seal
- T : Tapered shaft
 (applicable only to HA23, 33)
 No symbol : Straight shaft
 (other than HA40, 43, 80, 83)

| Motor | Symbol | Shaft |
|------------------|--------|----------|
| HA23, 33 | T | Tapered |
| | None | Straight |
| HA40, 80, 43, 83 | None | Tapered |
| | S | Straight |

- B : With electromagnetic brake
 No symbol : No electromagnetic brake
- C : Main circuit cannon connector type
 No symbol : Main circuit terminal box type
- N : Motor for M500 Series
 NL : Low inertia motor for M500 Series
 L : Conventional low inertia motor
 (Already changed to the same specification NL type)
 No symbol : Conventional motor

Motor power class

| N-type 2000r/min | | N-type 3000r/min | | L-type 2000r/min | | L-type 3000r/min | |
|---------------------|-----|---------------------|------|---------------------|------|---------------------|-----|
| Motor | kW | Motor | kW | Motor | kW | Motor | kW |
| 40 | 0.5 | 053 | 0.05 | 50 | 0.5 | 53 | 0.5 |
| 80 | 1.0 | 13 | 0.1 | 100 | 1.0 | 103 | 1.0 |
| 100 | 2.0 | 23 | 0.3 | 150 | 1.5 | 153 | 1.5 |
| 200 | 3.5 | 33 | 0.45 | 200 | 2.0 | 203 | 2.0 |
| 300 | 4.5 | 43 | 0.5 | 300 | 3.0 | 303 | 3.0 |
| 700 | 7.0 | 83 | 1.0 | 500 | 5.0 | 503 | 5.0 |
| 900 | 9.0 | 103 | 2.0 | -LH11K2 | 11.0 | | |
| | | 203 | 3.5 | -LH15K2 | 15.0 | | |
| | | 303 | 4.5 | | | | |
| | | 703 | 7.0 | | | | |

2. Motor

2.3 Main equipment list

HA motor main equipment

| Maximum speed | | 2000r/min | | | 3000r/min | | | | |
|------------------------|------------------|----------------|----------------------------|------------------|---------------|----------------|----------------|------------------|------------------|
| Motor model | | HA40N HA80N | HA100N HA200N HA300N | HA700N HA900N | HA053 HA13 | HA23N HA33N | HA43N HA83N | HA103N HA203N | HA303N HA703N |
| Item | | | | | | | | | |
| Oil seal | Presence | ○ | ○ | ○ | ○ | ○ | ○ | ○ | ○ |
| | Absence | × | × | × | × | × | × | × | × |
| Shaft end | Straight shaft | △ | ○ | ○ | ○ | ○ | △ | ○ | ○ |
| | Tapered shaft | ○ | × | × | × | ○ | ○ | × | × |
| Electro-magnetic brake | Presence | ○ | ○ | ○ | ○ | ○ | ○ | ○ | ○ |
| | Absence | ○ | ○ | ○ | ○ | ○ | ○ | ○ | ○ |
| Connector type | Cannon connector | ○ | ○ | △ | ○ | ○ | ○ | ○ | × |
| | Terminal box | × | × | ○ | × | × | × | × | ○ |
| IP65/67 compatible | | △ | △ | × | × | △ | △ | △ | × |

○ : Standard product △ : Special product × : No specification

| Maximum speed | | 2000r/min | | | 3000r/min | | |
|------------------------|------------------|------------------------------|-------------------------------|------------------------|------------------------------|--------------------|---------|
| Motor model | | HA50NL HA100NL HA150NL | HA200NL HA300NL HA500NL | HA-LH11K2 HA-LH15K2 | HA53NL HA103NL HA153NL | HA203NL HA303NL | HA503NL |
| Item | | | | | | | |
| Oil seal | Presence | ○ | ○ | ○ | ○ | ○ | ○ |
| | Absence | × | × | × | × | × | × |
| Shaft end | Straight shaft | ○ | ○ | ○ | ○ | ○ | ○ |
| | Tapered shaft | ○ | × | × | ○ | × | × |
| Electro-magnetic brake | Presence | × | × | × | × | × | × |
| | Absence | ○ | ○ | ○ | ○ | ○ | ○ |
| Connector type | Cannon connector | ○ | ○ | × | ○ | ○ | × |
| | Terminal box | × | × | ○ | × | × | ○ |
| IP65/67 compatible | | × | × | × | × | × | × |

○ : Standard product △ : Special product × : No specification

2. Motor

2.4 Specifications list

Servomotor specifications list

| Item | | Motor model | HA40N | HA80N | HA100N | HA200N | HA300N | HA700N | HA900N | HA053 | |
|---|-------------------------------------|--|--|----------------------|--------|--------|--------|-----------------------|--------|------------------|----|
| Motor characteristics during rated speed | Rated output | kW | 0.5 | 1.0 | 2.0 | 3.5 | 4.5 | 7 | 9 | 0.05 | |
| | Rated torque | N·m | 2.39 | 4.78 | 9.55 | 16.7 | 21.5 | 33.4 | 43.0 | 0.16 | |
| Stall torque | | N·m | 2.94 | 5.88 | 13.7 | 22.6 | 37.3 | 49.0 | 58.8 | 0.25 | |
| Maximum torque for drive unit combination | | N·m | 14.2 | 25.5 | 42.0 | 59.8 | 87.6 | 120 | 153 | 0.69 | |
| Rated speed | | r/min | 2000 | | | | | | | 3000 | |
| Motor inertia | Without brake | Jm $\times 10^{-4} \text{kg}\cdot\text{m}^2$ | 9.8 | 19.6 | 68.6 | 131.0 | 192.0 | 254.0 | 319.0 | 0.18 | |
| | | GD $\times 10^{-4} \text{kg}\cdot\text{m}^2$ | 39.2 | 78.4 | 274 | 525 | 768 | 1015 | 1274 | 0.74 | |
| | With brake | Jm $\times 10^{-4} \text{kg}\cdot\text{m}^2$ | 10.8 | 20.6 | 72.6 | 135.0 | 196.0 | 258.0 | 323.0 | 0.20 | |
| | | GD $\times 10^{-4} \text{kg}\cdot\text{m}^2$ | 41.9 | 81.1 | 291 | 542 | 785 | 1032 | 1291 | 0.80 | |
| Weight | Without brake | kg | 8 | 12 | 21 | 32 | 43 | 56 | 80 | 1.1 | |
| | With brake | kg | 10 | 14 | 27 | 38 | 49 | 62 | 85 | 1.5 | |
| Equipped parts | Thermal protector | | Built-in motor | | | | | | | | |
| | Shaft through-hole section oil seal | | Provided | | | | | | | | |
| | Electromagnetic brake | | 24VDC 15W 5.9N·m | 24VDC 15W 29.4N·m | | | | 24VDC 5.2W 0.39N·m | | | |
| | Cable connector | | Cannon connector | | | | | Terminal box | | Cannon connector | |
| | Motor shaft end detector | | Detector model name should be specified. | | | | | | | | *1 |
| Tolerable shaft end radial load | | kg | Tapered shaft 40 | | 210 | | | 250 | | 8 | |
| | | | Straight shaft 100 | | | | | | | | |
| Operating environment | | Ambient temperature: 0 to 40°C, free from oil and water, no condensation | | | | | | | | | |

| Item | | Motor model | HA13 | HA23N | HA33N | HA43N | HA83N | HA103N | HA203N | HA303N | HA703N |
|---|-------------------------------------|--|-----------------------|--|---------------------|----------------------|-------|--------|--------|--------------|--------|
| Motor characteristics during rated speed | Rated output | kW | 0.1 | 0.3 | 0.45 | 0.5 | 1.0 | 2.0 | 3.5 | 4.5 | 7.0 |
| | Rated torque | N·m | 0.32 | 0.95 | 1.43 | 1.60 | 3.19 | 6.37 | 11.2 | 14.3 | 22.3 |
| Stall torque | | N·m | 0.49 | 0.98 | 1.96 | 2.94 | 5.88 | 13.7 | 22.6 | 37.3 | 49.0 |
| Maximum torque for drive unit combination | | N·m | 1.37 | 2.7 | 5.59 | 10.2 | 19.2 | 40.2 | 55.9 | 79.8 | 105 |
| Rated speed | | r/min | 3000 | | | | | | | | |
| Motor inertia | Without brake | Jm $\times 10^{-4} \text{kg}\cdot\text{m}^2$ | 0.36 | 0.98 | 1.96 | 9.8 | 19.6 | 68.6 | 131.0 | 192.0 | 254.0 |
| | | GD $\times 10^{-4} \text{kg}\cdot\text{m}^2$ | 1.43 | 3.92 | 7.84 | 39.2 | 78.4 | 274 | 525 | 768 | 1015 |
| | With brake | Jm $\times 10^{-4} \text{kg}\cdot\text{m}^2$ | 0.37 | 1.08 | 2.06 | 10.8 | 20.6 | 72.6 | 135.0 | 196.0 | 258.0 |
| | | GD $\times 10^{-4} \text{kg}\cdot\text{m}^2$ | 1.49 | 4.72 | 8.64 | 41.9 | 81.1 | 291 | 542 | 785 | 1032 |
| Weight | Without brake | kg | 1.5 | 3.5 | 4.5 | 8 | 12 | 21 | 32 | 43 | 56 |
| | With brake | kg | 1.9 | 4.5 | 5.5 | 10 | 14 | 27 | 38 | 49 | 62 |
| Equipped parts | Thermal protector | | Built-in motor | | | | | | | | |
| | Shaft through-hole section oil seal | | Provided | | | | | | | | |
| | Electromagnetic brake | | 24VDC 5.2W 0.39N·m | 24VDC 12W 2.0N·m | 24VDC 15W 5.9N·m | 24VDC 25W 29.4N·m | | | | | |
| | Cable connector | | Cannon connector | | | | | | | Terminal box | |
| | Motor shaft end detector | | *1 | Detector model name should be specified. | | | | | | | |
| Tolerable shaft end radial load | | kg | 8 | 25 | | Tapered shaft 40 | | 210 | | | |
| | | | | | | Straight shaft 100 | | | | | |
| Operating environment | | Ambient temperature: 0 to 40°C, free from oil and water, no condensation | | | | | | | | | |

(Note) *1: Detector model name need not be specified.

2. Motor

Low inertia servomotor specifications list

| Motor model | | | HA50NL | HA100NL | HA150NL | HA200NL | HA300NL | HA500NL | HA-LH11K2 |
|---|-------------------------------------|--|---|---------|---------|---------|---------|---------|--------------|
| Motor characteristics during rated speed | Rated output | kW | 0.5 | 1 | 1.5 | 2 | 3 | 5 | 11 |
| | Rated torque | N·m | 2.39 | 4.78 | 7.16 | 9.55 | 14.3 | 23.8 | 52.5 |
| Stall torque | | N·m | 2.94 | 5.88 | 8.83 | 13.7 | 22.6 | 37.3 | 70.6 |
| Maximum torque for drive unit combination | | N·m | 13.0 | 20.9 | 31.4 | 31.7 | 52.0 | 72.6 | 158 |
| Rated speed | | r/min | 2000 | | | | | | |
| Motor inertia | Without brake | Jm $\times 10^{-4} \text{kg}\cdot\text{m}^2$ | 2.75 | 5.49 | 8.24 | 19.6 | 29.4 | 88.3 | 118.0 |
| | | GD $\times 10^{-4} \text{kg}\cdot\text{m}^2$ | 11 | 22 | 33 | 78.4 | 118 | 353 | 470 |
| Weight | Without brake | kg | 6.5 | 9.5 | 12.5 | 16 | 22 | 35 | 70 |
| Equipped parts | Shaft through-hole section oil seal | | Provided | | | | | | |
| | Cable connector | | Cannon connector | | | | | | Terminal box |
| | Motor shaft end detector | | Detector model name should be specified (corresponding to INC or ABS). | | | | | | |
| Tolerable shaft end radial load | kg | Tapered shaft 40 | | 210 | | | 250 | | |
| | | Straight shaft 100 | | | | | | | |
| Operating environment | | | Ambient temperature: 0 to 40°C, free from oil and water, no condensation. | | | | | | |

| Motor model | | | HA-LH15K2 | HA53NL | HA103NL | HA153NL | HA203NL | HA303NL | HA503NL |
|---|-------------------------------------|--|---|------------------|---------|---------|---------|---------|--------------|
| Motor characteristics during rated speed | Rated output | kW | 15 | 0.5 | 1 | 1.5 | 2 | 3 | 5 |
| | Rated torque | N·m | 71.6 | 1.60 | 3.19 | 4.77 | 6.36 | 9.55 | 16.0 |
| Stall torque | | N·m | 91.7 | 2.94 | 5.88 | 8.82 | 13.7 | 22.5 | 37.3 |
| Maximum torque for drive unit combination | | N·m | 215 | 14.1 | 22.5 | 22.8 | 37 | 60 | 78 |
| Rated speed | | r/min (rpm) | 3000 | | | | | | |
| Motor inertia | Without brake | Jm $\times 10^{-4} \text{kg}\cdot\text{m}^2$ | 290.0 | 2.7 | 5.5 | 8.2 | 19.6 | 29.4 | 88.3 |
| | | GD $\times 10^{-4} \text{kg}\cdot\text{m}^2$ | 1160 | 11 | 22 | 33 | 78.4 | 117.6 | 352.8 |
| Weight | Without brake | kg | 108 | 6.5 | 9.5 | 12.5 | 16 | 22 | 35 |
| Equipped parts | Shaft through-hole section oil seal | | Provided | | | | | | |
| | Cable connector | | Terminal box | Cannon connector | | | | | Terminal box |
| | Motor shaft end detector | | Detector model name should be specified (corresponding to INC or ABS). | | | | | | |
| Tolerable shaft end radial load | kg | Tapered shaft 40 | | 210 | | | 250 | | |
| | | Straight shaft 100 | | | | | | | |
| Operating environment | | | Ambient temperature: 0 to 40°C, free from oil and water, no condensation. | | | | | | |

2. Motor

| Encoder | |
|-------------------------|---------|
| INC | OHE2500 |
| Not compatible with AMS | |

| Motor model | Dimensions | | Weight (kg) | Tolerable shaft end radial load (kg) | Shaft shape | Electromagnetic brake |
|-------------|------------|----|-------------|--------------------------------------|----------------|-----------------------|
| | A | B | | | | |
| HA053CB-S | 156 | 81 | 1.5 | 8 | Straight shaft | 24VDC 0.39N·m |
| HA13CB-S | 173 | 98 | 1.9 | | | |

- Notes:
1. It is recommended that the cannon connector be mounted in a downward orientation to improve its splash-proof performance.
 2. The wiring side plug is optional. It is only provided when ordered.
 3. The detector connector direction cannot be changed.

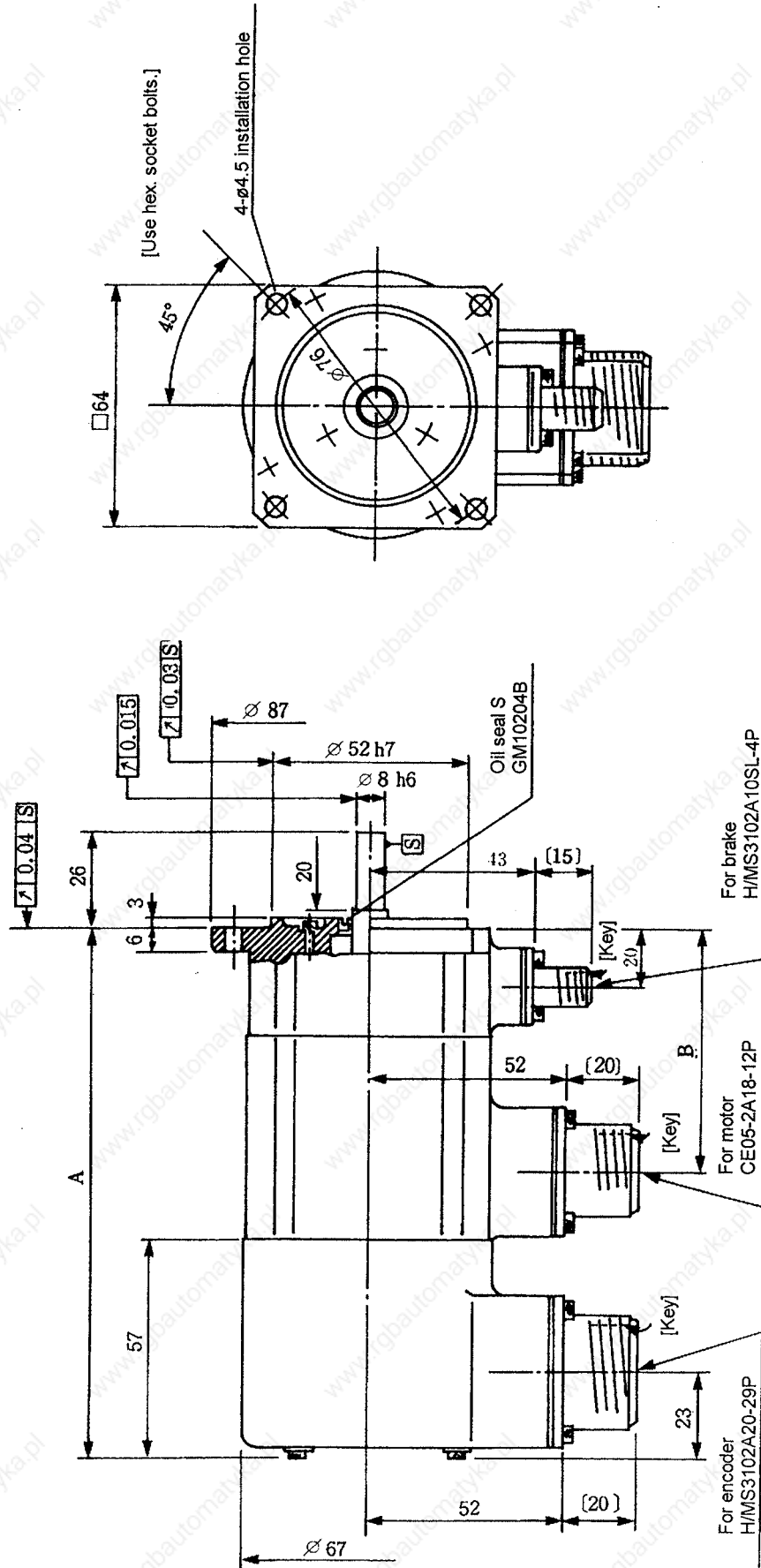

Outline dimension drawing

2. Motor

| Serial encoder | | |
|----------------|-----------------|-------------|
| Spec. | Model name | Dimension C |
| INC | OSE104S/OSE105S | 45 |
| ABS | OSA104S/OSA105S | 45 |

| Conventional encoder | | |
|----------------------|------------|-------------|
| Spec. | Model name | Dimension C |
| INC | OHE25K-85 | 70 |
| ABS | OHA25K-85 | 70 |

| Motor model | Dimensions | | Weight (kg) | Tolerable shaft end radial load (kg) | Shaft shape | Electro-magnetic brake |
|-------------|------------|-----|-------------|--------------------------------------|----------------|------------------------|
| | A | B | | | | |
| HA23NC-TS | 125 | 81 | 3.5 | 25 | Tapered shaft | 24VDC 1.96N·m |
| HA33NC-TS | 155 | 111 | 4.5 | | Straight shaft | |
| HA23NC-S | 125 | 81 | 3.5 | | | |
| HA33NC-S | 155 | 111 | 4.5 | | | |

Notes: 1. It is recommended that the cannon connector be mounted in a downward orientation to improve its splash-proof performance.
2. The wiring side plug is optional. It is only provided when ordered.

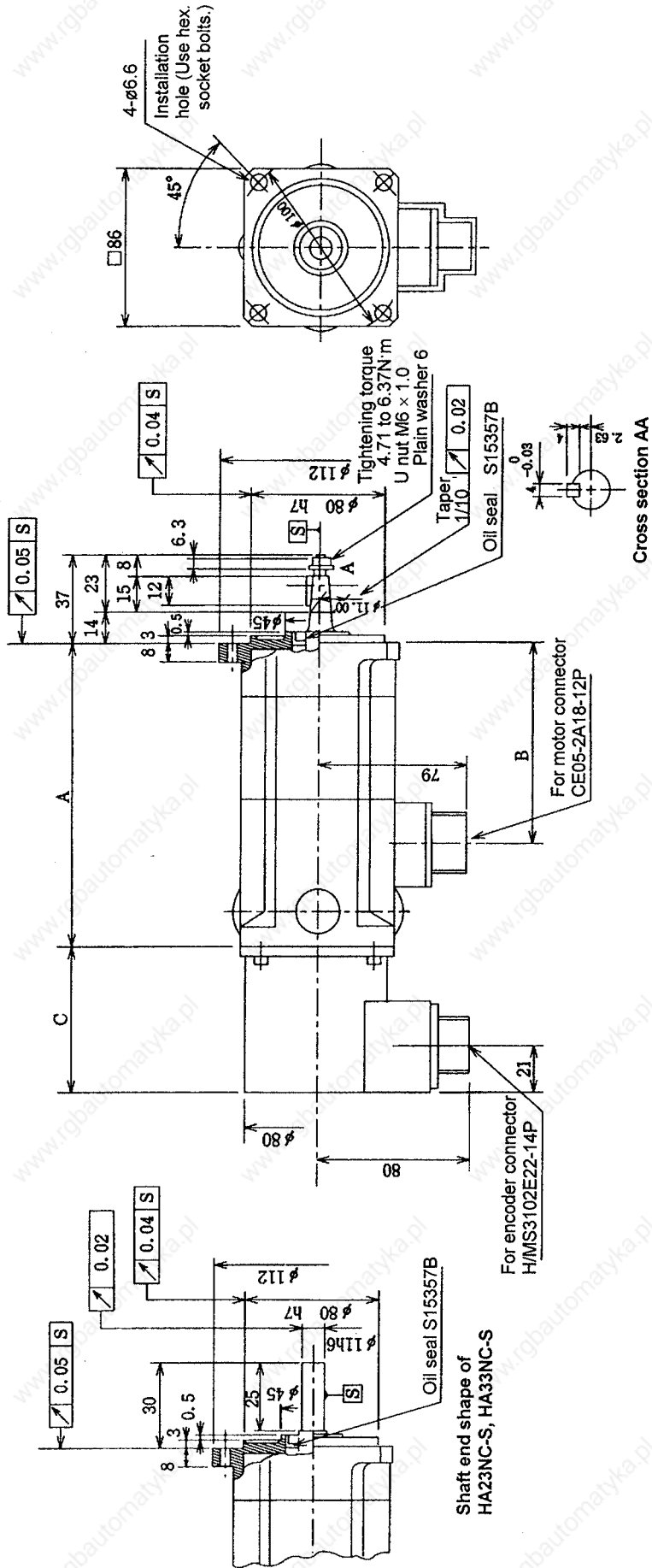

Outline dimension drawing

2. Motor

| Serial encoder | |
|----------------|-----------------|
| Spec. | Model name |
| INC | OSE104S/OSE105S |
| ABS | OSA104S/OSA105S |
| | Dimension C |
| | 45 |

| Conventional encoder | |
|----------------------|-------------|
| Spec. | Model name |
| INC | OHE25K-85 |
| ABS | OHA25K-85 |
| | Dimension C |
| | 70 |

| Motor model | Dimensions | | Weight (kg) | Tolerable shaft end radial load (kg) | Shaft shape | Electro-magnetic brake |
|-------------|------------|-----|-------------|--------------------------------------|----------------|------------------------|
| | A | B | | | | |
| HA23NCB-TS | 162 | 81 | 4.5 | 25 | Tapered shaft | 24VDC 1.92N·m |
| HA33NCB-TS | 192 | 111 | 5.5 | | Straight shaft | |
| HA23NCB-S | 162 | 81 | 4.5 | | | |
| HA33NCB-S | 192 | 111 | 5.5 | | | |

Notes: 1. It is recommended that the cannon connector be mounted in a downward orientation to improve its splash-proof performance.
2. The wiring side plug is optional. It is only provided when ordered.

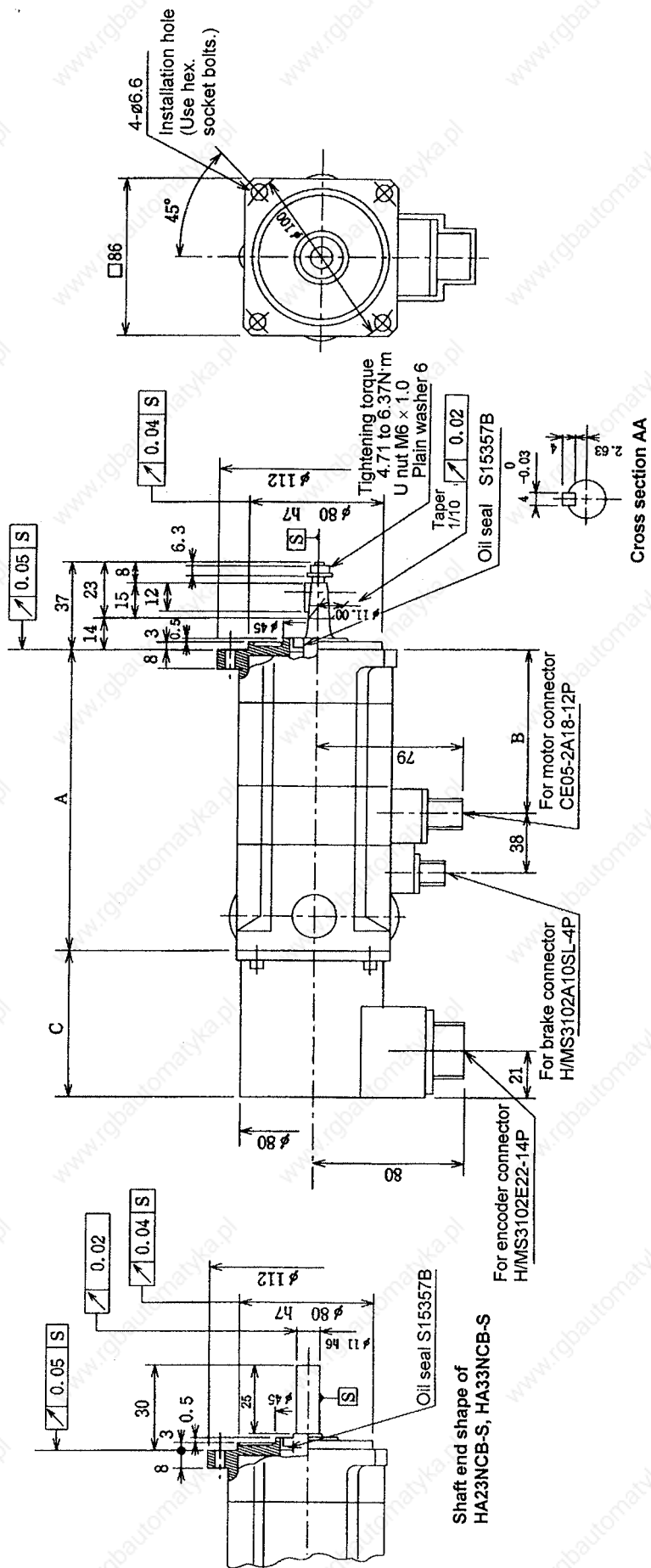

Outline dimension drawing

2. Motor

| Motor model | Dimensions | | Weight (kg) | Tolerable shaft end radial load (kg) | Shaft shape | Electromagnetic brake | Encoder |
|-------------------------|------------|-----|-------------|--------------------------------------|----------------|-----------------------|--|
| | A | B | | | | | |
| HA40NC-S • HA43NC-S | 214 | 131 | 8 | 40 | Tapered shaft | None | INC OHE25K-6, OSE104, OSE105 ABS OHA25K-4, OSA104, OSA105 |
| HA80NC-S • HA83NC-S | 254 | 171 | 12 | | | | |
| HA40NCB-S • HA43NCB-S | 270 | 131 | 10 | | | | |
| HA80NCB-S • HA83NCB-S | 310 | 171 | 14 | | | | |
| HA40NC-SS • HA43NC-SS | 214 | 131 | 8 | 100 | Straight shaft | None | |
| HA80NC-SS • HA83NC-SS | 254 | 171 | 12 | | | | |
| HA40NCB-SS • HA43NCB-SS | 270 | 131 | 10 | | | | |
| HA80NCB-SS • HA83NCB-SS | 310 | 171 | 14 | | | | |

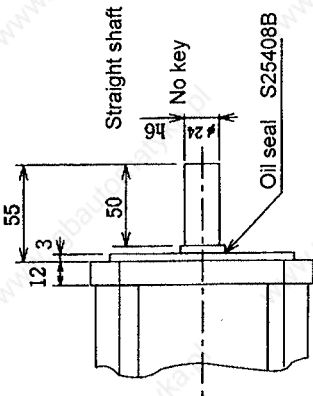

[Use hex. socket bolts.]

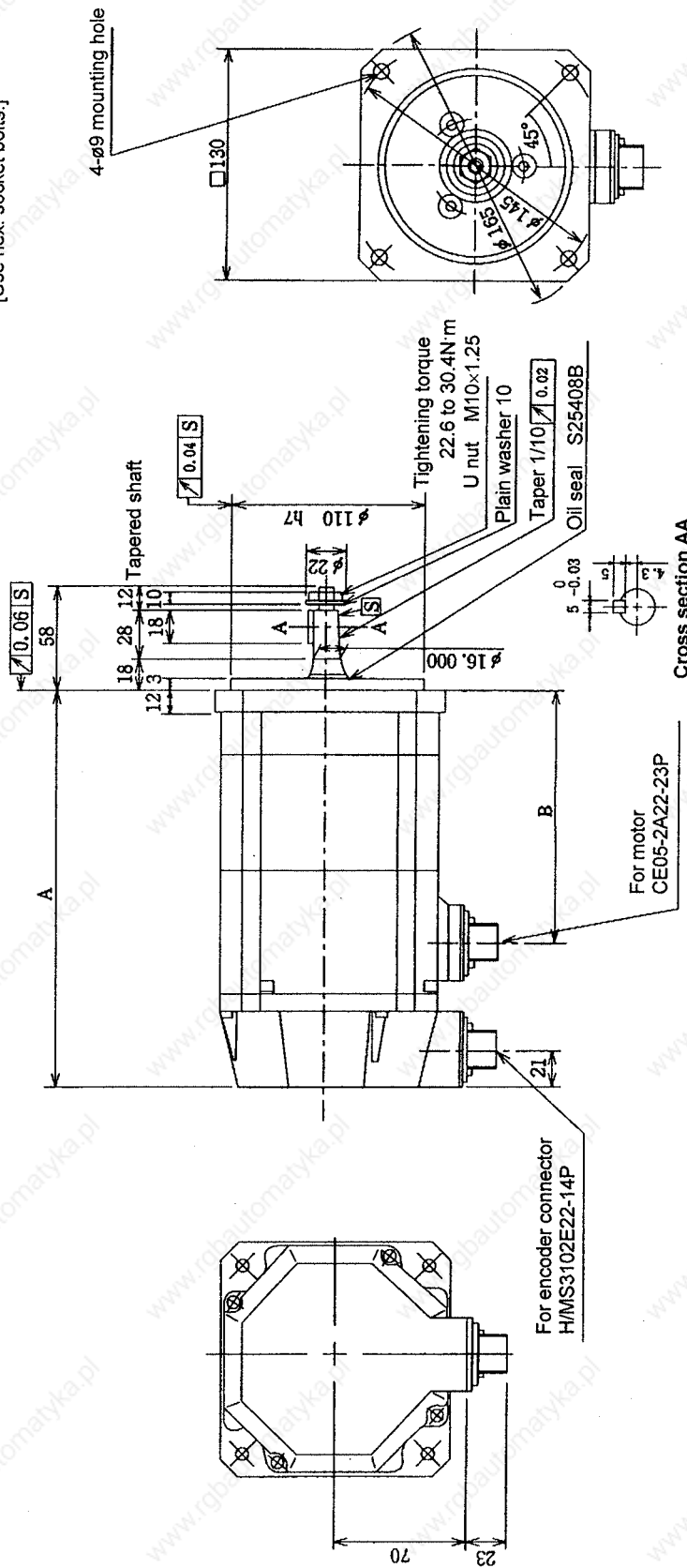

Outline dimension drawing

Notes: 1. It is recommended that the cannon connector be mounted in a downward orientation to improve its splash-proof performance.
2. The wiring side plug is optional. It is only provided when ordered.

2. Motor

| Encoder | |
|---------|--------------------------|
| INC | OHE25K-6, OSE104, OSE105 |
| ABS | OHA25K-4, OSA104, OSA105 |

| Motor model | Dimensions | | Weight (kg) | Tolerable shaft end radial load (kg) | Shaft shape | Electro-magnetic brake |
|-------------------------|------------|-----|-------------|--------------------------------------|----------------|------------------------|
| | A | B | | | | |
| HA303N-SR | 395 | 280 | 43 | 210 | Straight shaft | None |
| HA700N-SR • HA703N-SR | 479 | 364 | 56 | | | |
| HA303NB-SR | 472 | 280 | 49 | | | |
| HA700NB-SR • HA703NB-SR | 556 | 364 | 62 | | | |

4- ϕ 13.5 installation hole
Use hex. socket bolts.

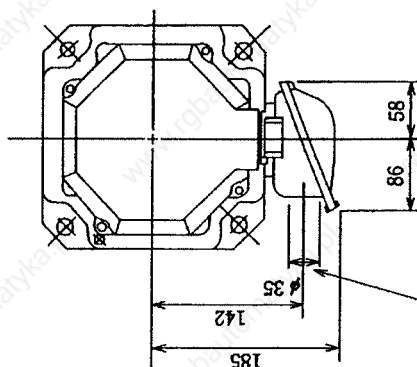
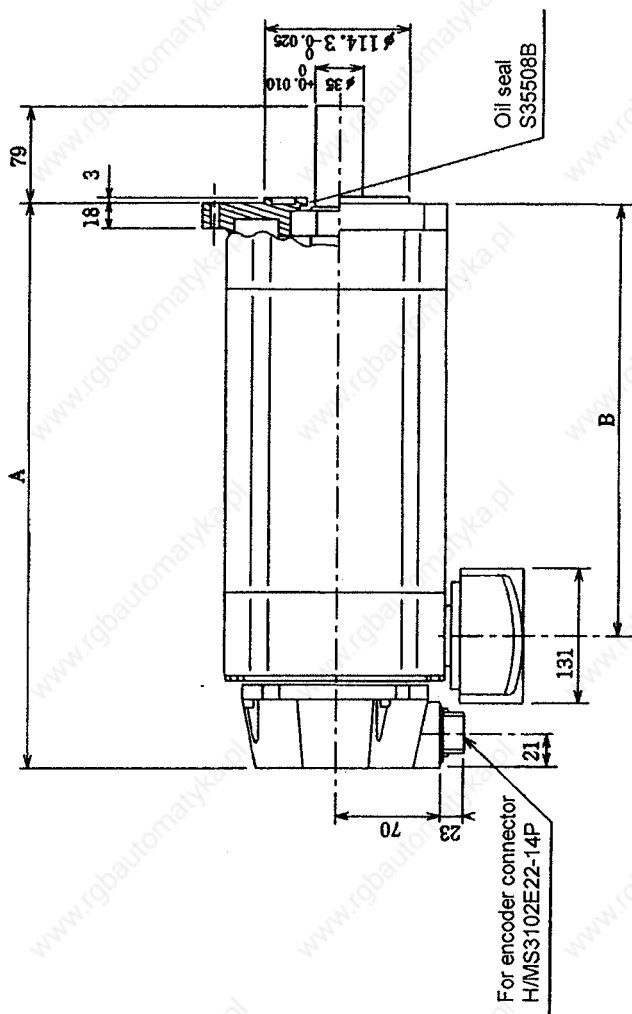

The motor terminal box lead outlet direction can be changed forward/backward/right/left with a 90° angle.
A steel sealed type terminal box is used.

Outline dimension drawing

2. Motor

| Motor model | | Dimensions | | Weight (kg) | Tolerable shaft end radial load (kg) | Shaft shape | Electro-magnetic brake | Encoder | |
|-------------|--|------------|-----|-------------|--------------------------------------|----------------|------------------------|--------------------------|-----|
| | | A | B | | | | | INC | ABS |
| HA900N-SR | | 565 | 450 | 79 | 250 | Straight shaft | None | OHE25K-6, OSE104, OSE105 | |
| HA900NB-SR | | 642 | 450 | 85 | | | | OHA25K-4, OSA104, OSA105 | |

| Motor model | Dimensions | | Weight (kg) | Tolerable shaft end radial load (kg) | Shaft shape | Electro-magnetic brake |
|-------------|------------|-----|-------------|--------------------------------------|----------------|------------------------|
| | A | B | | | | |
| HA900N-SR | 565 | 450 | 79 | 250 | Straight shaft | None |
| HA900NB-SR | 642 | 450 | 85 | | | 29.4N·m with 24VDC |

4- \varnothing 15 installation hole
Use hex. socket bolts.

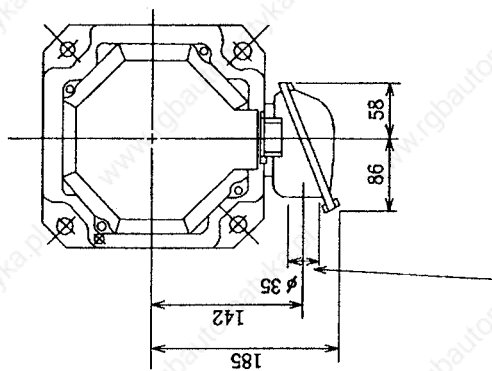
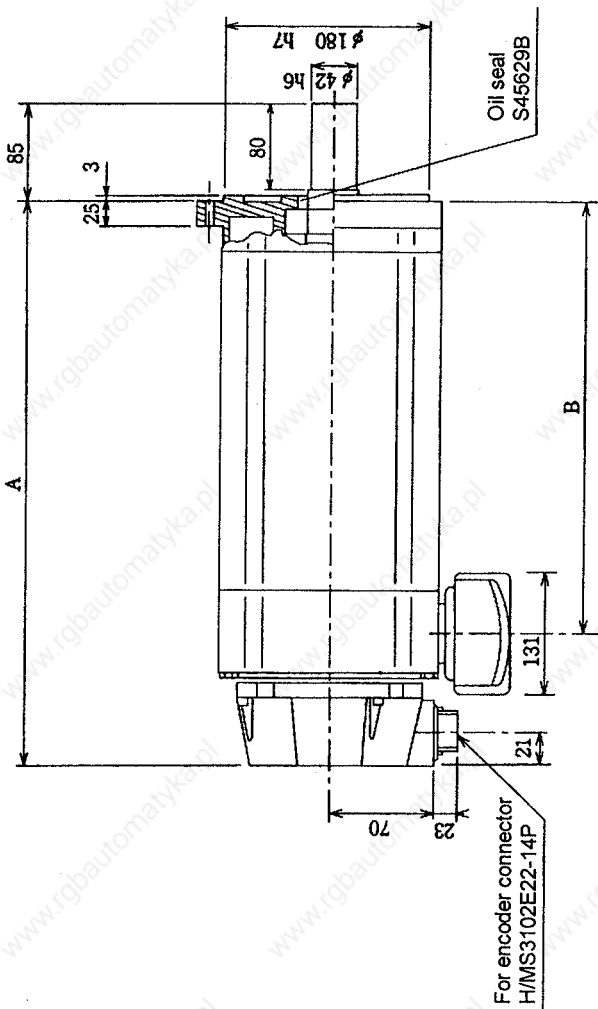

Outline dimension drawing

2. Motor

| Spec. | Serial encoder | |
|-------|-----------------|----------------|
| | Model name | Adaptor dim. E |
| INC | OSE104S/OSE105S | 45 |
| ABS | OSA104S/OSA105S | 28 |

| Spec. | Conventional encoder | |
|-------|----------------------|--------|
| | Model name | Dim. C |
| INC | OHE25K-108 | 98 |
| ABS | OHA25K-108 | 98 |

| Motor model | Dimensions A | | Dimension B | Weight (kg) | Tolerable shaft end radial load (kg) | Shaft shape |
|-------------------------|--------------|--------------|-------------|-------------|--------------------------------------|----------------|
| | OHE/OHA type | OSE/OSA type | | | | |
| HA50LC-TS·HA53LC-TS | 238 | 213 | 117 | 6.5 | 40 | Tapered shaft |
| HA100LC-TS·HA103LC-TS | 278 | 253 | 157 | 9.5 | | |
| HA150LC-TS·HA153LC-TS | 328 | 303 | 207 | 12.5 | 100 | Straight shaft |
| HA50LC-S·HA53LC-S | 238 | 213 | 117 | 6.5 | | |
| HA100LC-S·HA103LC-S | 278 | 253 | 157 | 9.5 | 40 | Tapered shaft |
| HA150LC-S·HA153LC-S | 328 | 303 | 207 | 12.5 | | |
| HA50NLC-TS·HA53NLC-TS | - | 213 | 117 | 6.5 | 100 | Straight shaft |
| HA100NLC-TS·HA103NLC-TS | - | 253 | 157 | 9.5 | | |
| HA150NLC-TS·HA153NLC-TS | - | 303 | 207 | 12.5 | 40 | Tapered shaft |
| HA50NLC-S·HA53NLC-S | - | 213 | 117 | 6.5 | | |
| HA100NLC-S·HA103NLC-S | - | 253 | 157 | 9.5 | 100 | Straight shaft |
| HA150NLC-S·HA153NLC-S | - | 303 | 207 | 12.5 | | |

Notes: 1. It is recommended that the cannon connector be mounted in a downward orientation to improve its splash-proof performance.

2. The wiring side plug is optional. It is only provided when ordered.

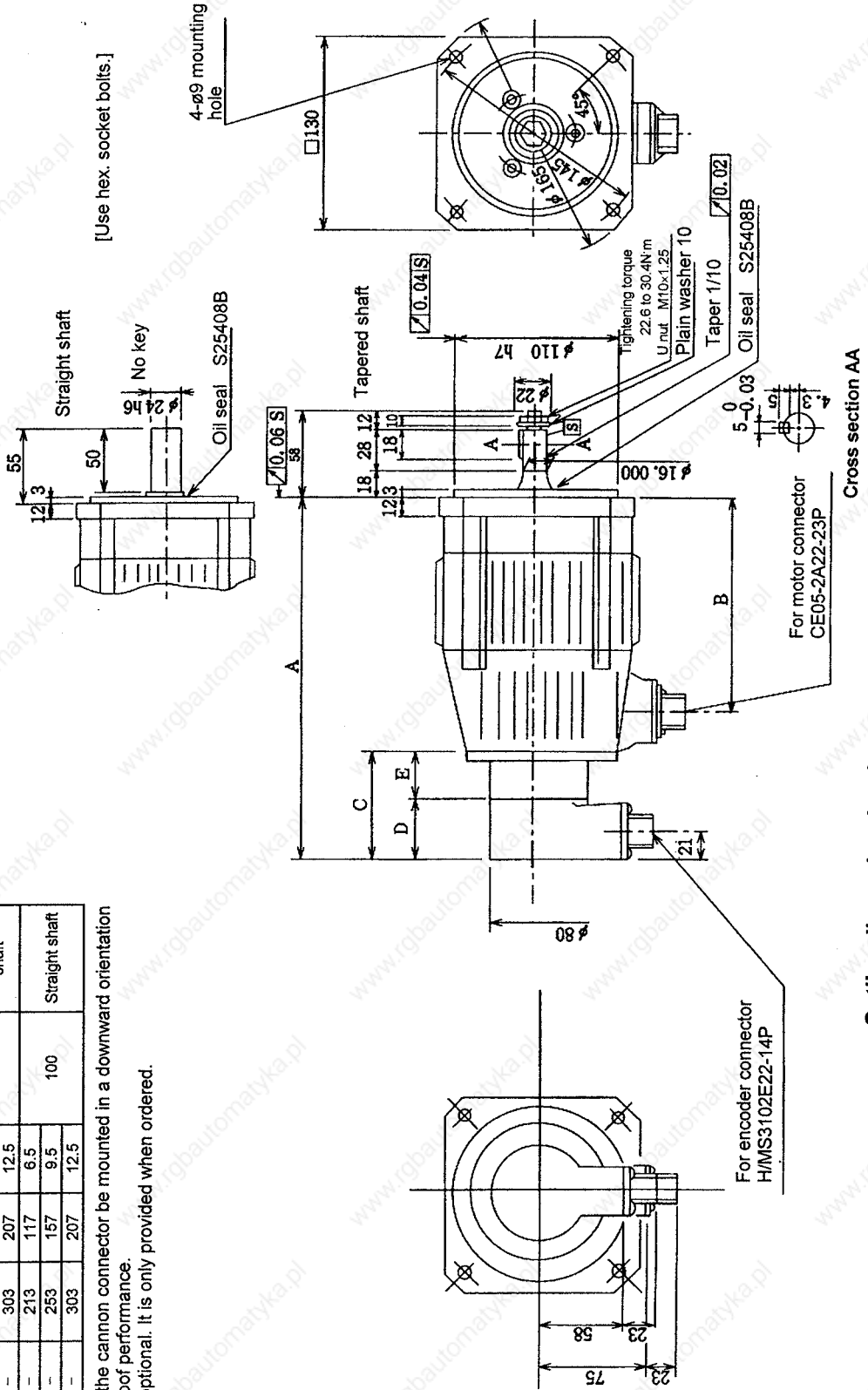

Outline dimension drawing

2. Motor

| Spec. | Serial encoder | |
|-------|-----------------|----------------|
| | Model name | Encoder dim. E |
| INC | OSE104S/OSA105S | 45 |
| ABS | OSA104S/OSA105S | 45 |

| Spec. | Conventional encoder | |
|-------|----------------------|--------|
| | Model name | Dim. C |
| INC | OHE25K-108 | 98 |
| ABS | OHA25K-108 | 98 |

| Motor model | Dimensions A | | Tolerable shaft end radial load (kg) | Shaft shape |
|-----------------------|--------------|--------------|--------------------------------------|----------------|
| | OHE/OHA type | OSE/OSA type | | |
| HA200LC-S-HA203LC-S | 293 | 268 | 210 | Straight shaft |
| HA300LC-S-HA303LC-S | 333 | 308 | | |
| HA200NLC-S-HA203NLC-S | - | 268 | 210 | Straight shaft |
| HA300NLC-S-HA303NLC-S | - | 308 | | |

- Notes:
1. It is recommended that the cannon connector be mounted in a downward orientation to improve its splash-proof performance.
 2. The wiring side plug is optional. It is only provided when ordered.

Use hex. socket bolts for motor installation.

4- ϕ 13.5
Installation holes

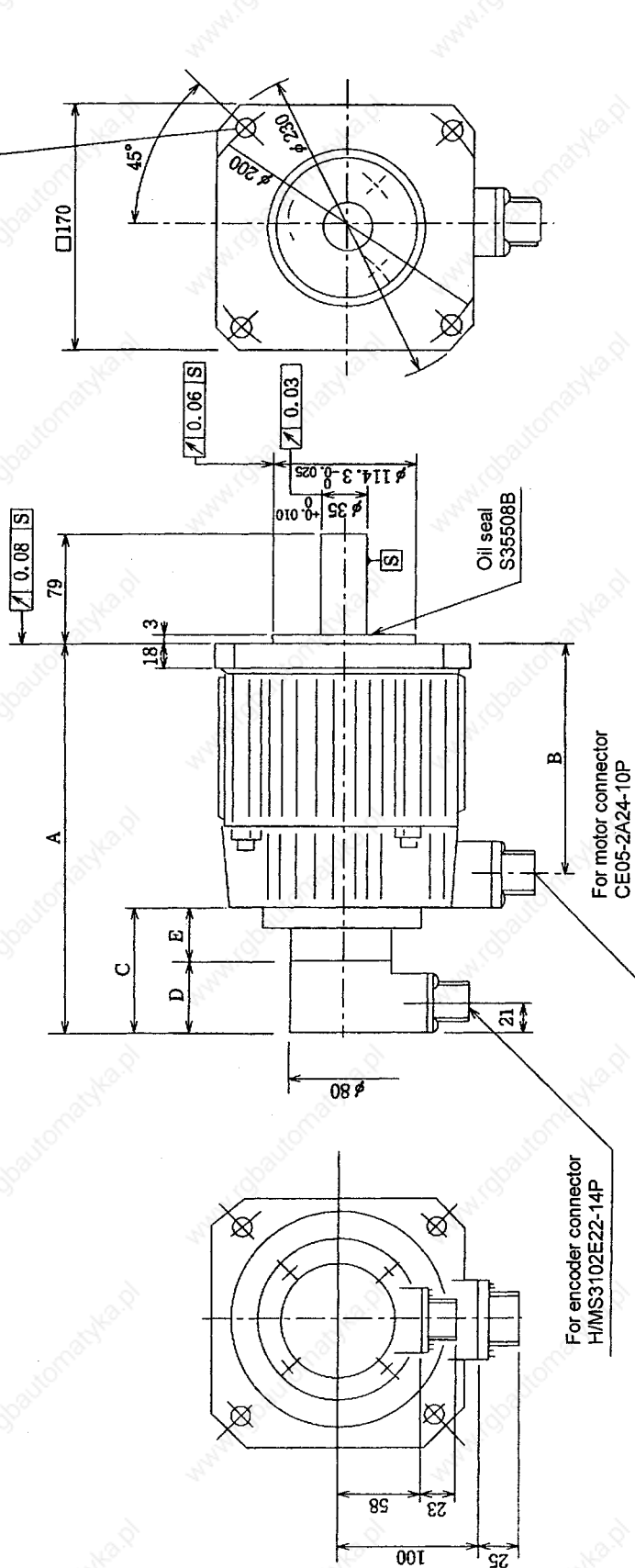

Outline dimension drawing

2. Motor

| Motor model | Dimensions A | | Tolerable shaft end radial load (kg) | Weight (kg) | Shaft shape | Conventional encoder | | Serial encoder | | | |
|-------------|--------------|--------------|--------------------------------------|-------------|----------------|----------------------|------------|----------------|-----------------|----------------|----------------|
| | OHE/OHA type | OSE/OSA type | | | | Model name | Dim. C | Spec. | Model name | Encoder dim. D | Adaptor dim. E |
| HA500LC-S | 353 | 338 | 250 | 35 | Straight shaft | INC | OHE25K-108 | INC | OSE104S/OSE105S | 45 | 28 |
| HA500NLC-S | - | 338 | 250 | 35 | Straight shaft | ABS | OHA25K-108 | ABS | OSA104S/OSA105S | 45 | 28 |

| Motor model | Dimensions A | | Tolerable shaft end radial load (kg) | Weight (kg) | Shaft shape | Conventional encoder | | Serial encoder | | | |
|-------------|--------------|--------------|--------------------------------------|-------------|----------------|----------------------|------------|----------------|-----------------|----------------|----------------|
| | OHE/OHA type | OSE/OSA type | | | | Model name | Dim. C | Spec. | Model name | Encoder dim. D | Adaptor dim. E |
| HA500LC-S | 353 | 338 | 250 | 35 | Straight shaft | INC | OHE25K-108 | INC | OSE104S/OSE105S | 45 | 28 |
| HA500NLC-S | - | 338 | 250 | 35 | Straight shaft | ABS | OHA25K-108 | ABS | OSA104S/OSA105S | 45 | 28 |

Notes: 1. It is recommended that the cannon connector be mounted in a downward orientation to improve its splash-proof performance.

2. The wiring side plug is optional. It is only provided when ordered.

3. M8 screw holes for suspension bolts are machined in the positions marked ※1 to ※3.

Use hex. socket bolts for motor installation.

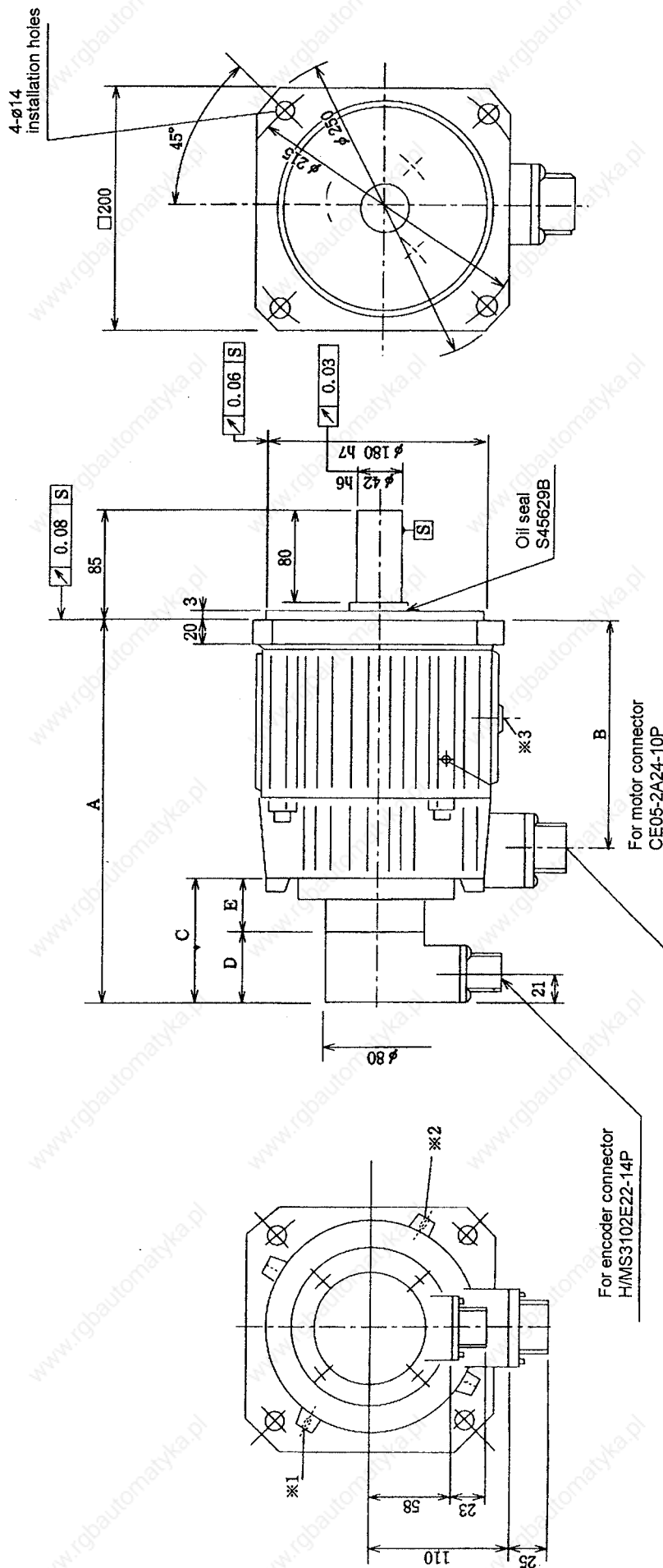

Outline dimension drawing

● Servomotor HA-LH11K2-S1 ~ HA-LH15K2-S1

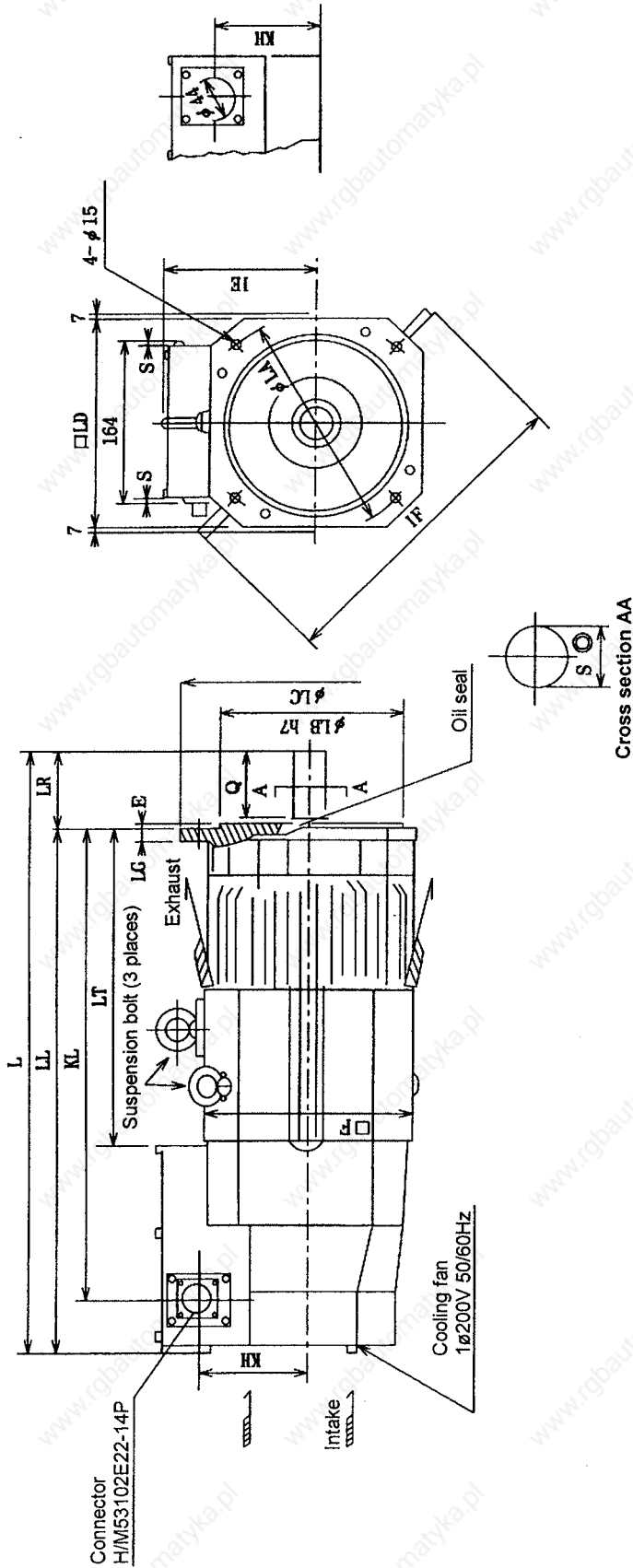

| Model | Motor | | | | | | | | | | | | | | Shaft end | | | | Weight (kg) | | |
|--------------|-------|-----|-----|-----|-----|-----|----|-----|-----|-----|-----|-----|-----|-----------------|-----------|-----|-----|----|-------------|---------|----------|
| | F | L | LA | LB | LC | LD | LG | LL | LT | KL | KH | IE | IF | Suspension bolt | E | LR | Q | S | | ⊙ | Oil seal |
| HA-LH11K2-S1 | 208 | 614 | 215 | 180 | 250 | 204 | 20 | 529 | 316 | 478 | 102 | 152 | 317 | M10 | 3 | 85 | 80 | 42 | h6 | S45G29B | 70 |
| HA-LH15K2-S1 | 254 | 688 | 265 | 230 | 300 | 250 | 25 | 578 | 365 | 527 | 117 | 180 | 376 | M12 | 3 | 110 | 100 | 55 | m6 | S60S29B | 108 |

Unit : mm

- (Note)
1. Leave 30mm or more between the cooling fan and wall.
 2. Do not use a friction coupling (spun ring, etc.) for the coupling with the load.
 3. When removing the suspension bolts and using the motor, plug the screw holes with bolts.
 4. This motor is equivalent to IP44, so take care to oil.

2. Motor

2.6 Data sheet

(1) Characteristics list

Standard motor data sheet

| Item | Symbol | Unit | HA40N | HA80N | HA100N | HA200N | HA300N | HA700N | HA900N | |
|--|----------------|---|-------|-------|--------|--------|--------|--------|--------|--|
| Nominal output | P_R | kW | 0.5 | 1.0 | 2.0 | 3.5 | 4.5 | 7.0 | 9.0 | |
| | T_R | N·m | 2.39 | 4.78 | 9.55 | 16.7 | 21.5 | 33.4 | 43.0 | |
| Rated speed | I_R | A | 3.0 | 5.5 | 10 | 16 | 22 | 33.5 | 42 | |
| | T_S | N·m | 2.94 | 5.88 | 13.7 | 22.6 | 37.3 | 49.0 | 58.8 | |
| Stall state | L_S | A | 3.6 | 6.6 | 14 | 22 | 37 | 49 | 56 | |
| | T_{PS} | N·m | 14.7 | 29.4 | 68.6 | 112.7 | 186 | 245 | 294 | |
| Maximum characteristics in stall state | I_P | A | 18 | 33 | 70 | 110 | 185 | 245 | 280 | |
| | Q_P | kW/sec | 220 | 440 | 686 | 967 | 1805 | 2364 | 2713 | |
| Instantaneous characteristics | a_p | rad/sec ² | 15000 | 15000 | 10000 | 8582 | 9694 | 9652 | 9230 | |
| | N_{max} | r/min | 2000 | | | | | | | |
| Rated speed | GD^2_M | $\times 10^{-4} \text{kg}\cdot\text{m}^2$ | 39.2 | 78.4 | 274 | 525 | 768 | 1015 | 1274 | |
| Rotor inertia | J_M | $\times 10^{-4} \text{kg}\cdot\text{m}^2$ | 9.8 | 19.6 | 68.6 | 131.0 | 192.0 | 254.0 | 319.0 | |
| Armature resistance (one phase, 20°C) | R_a | Ω | 2.23 | 0.89 | 0.31 | 0.136 | 0.067 | 0.058 | 0.045 | |
| Armature inductance (one phase) | L_a | mH | 9.6 | 4.9 | 3.6 | 1.8 | 1.1 | 0.86 | 0.8 | |
| Induced voltage constant (one phase, 20°C) | K_E | mV/rpm $\pm 10\%$ | 29.2 | 32 | 34.9 | 36.7 | 35.8 | 37 | 38 | |
| Torque constant | K_T | N·m/A $\pm 10\%$ | 0.83 | 0.91 | 1.00 | 1.05 | 1.03 | 1.06 | 1.09 | |
| Electrical time constant | t_e | msec | 4.3 | 5.5 | 11.6 | 13 | 16 | 14.8 | 17.8 | |
| Mechanical time constant | t_m | msec | 9.4 | 6.2 | 6.4 | 4.9 | 3.7 | 4.0 | 3.3 | |
| Thermal time constant | t_{th} | min | 40 | 45 | 60 | 65 | 65 | 65 | 65 | |
| Static frictional torque | T_f | N·m | 0.108 | 0.157 | 0.137 | 0.216 | 0.294 | 0.373 | 0.686 | |
| Armature winding temperature rise limit θ_{max} | θ_{max} | °C | 130 | 130 | 130 | 130 | 130 | 130 | 130 | |
| Weight (motor only) | — | kg | 7 | 11 | 20 | 31 | 42 | 55 | 79 | |
| Armature insulation class | Class F | | | | | | | | | |

2. Motor

Standard motor data sheet

| Item | Symbol | Unit | HA053 | HA13 | HA23N | HA33N | HA43N | HA83N | HA103N | HA203N | HA303N | HA703N |
|--|------------------------------|-------------------------------------|---------|-------|-------|-------|-------|-------|--------|--------|--------|--------|
| Nominal output | P _R | kW | 0.05 | 0.1 | 0.3 | 0.45 | 0.5 | 1.0 | 2.0 | 3.5 | 4.5 | 7.0 |
| | T _R | N·m | 0.16 | 0.32 | 0.95 | 1.43 | 1.60 | 3.19 | 6.37 | 11.2 | 14.3 | 22.3 |
| Rated speed | I _R | A | 0.95 | 0.95 | 2.9 | 2.2 | 2.8 | 4.9 | 9.2 | 18 | 21 | 31 |
| Stall state | T _s | N·m | 0.25 | 0.49 | 0.98 | 1.96 | 2.94 | 5.88 | 13.7 | 22.6 | 37.3 | 49.0 |
| | L _s | A | 1.4 | 1.4 | 3.0 | 3.0 | 5 | 8.8 | 19.6 | 34.5 | 55 | 68 |
| Maximum characteristics in stall state | T _{ps} | N·m | 1.22 | 2.45 | 4.9 | 9.8 | 15.7 | 29.4 | 68.6 | 113 | 186 | 245 |
| | I _p | A | 7.0 | 7.0 | 15 | 15 | 25 | 44 | 98 | 127.5 | 275 | 340 |
| | Q _p | kW/sec | 81.4 | 167.0 | 24500 | 490 | 220 | 440 | 686 | 967 | 1805 | 2364 |
| Instantaneous characteristics | a _p | rad/sec ² | 66490 | 68490 | 50000 | 50000 | 15000 | 15000 | 10000 | 8582 | 9694 | 9652 |
| Rated speed | N _{max} | r/min | 3000 | | | | | | | | | |
| Rotor GD ² | GD ² _M | ×10 ⁻⁴ kg·m ² | 0.74 | 1.43 | 3.92 | 7.84 | 39.2 | 78.4 | 274 | 525 | 768 | 1015 |
| Rotor inertia | J _M | ×10 ⁻⁴ kg·m ² | 0.18 | 0.36 | 0.98 | 1.96 | 9.8 | 19.6 | 68.6 | 131.0 | 192.0 | 254.0 |
| Armature resistance (one phase, 20°C) | R _a | Ω | 7.2 | 9.3 | 2.22 | 3.0 | 1.16 | 0.5 | 0.18 | 0.052 | 0.0316 | 0.0244 |
| Armature inductance (one phase) | L _a | mH | 6.4 | 10.8 | 4.4 | 8.7 | 5 | 2.8 | 2.1 | 0.72 | 0.46 | 0.42 |
| Induced voltage constant (one phase, 20°C) | K _E | mV/rpm±10% | 6.2 | 12.4 | 12.1 | 24.2 | 21 | 23.9 | 24.8 | 23 | 24.5 | 25.8 |
| Torque constant | K _T | N·m/A±10% | 0.18 | 0.35 | 0.34 | 0.69 | 0.60 | 0.69 | 0.71 | 0.66 | 0.71 | 0.75 |
| Electrical time constant | t _e | msec | 0.89 | 1.16 | 2.0 | 2.9 | 4.3 | 5.6 | 11.7 | 14 | 15 | 17 |
| Mechanical time constant | t _m | msec | 12.8 | 8.0 | 5.5 | 3.7 | 9.5 | 6.3 | 7.4 | 4.6 | 3.7 | 3.4 |
| Thermal time constant | t _{th} | min | 10 | 10 | 20 | 25 | 40 | 45 | 60 | 65 | 65 | 65 |
| Static frictional torque | T _F | N·m | 0.005 | 0.007 | 0.039 | 0.059 | 0.108 | 0.157 | 0.137 | 0.216 | 0.294 | 0.373 |
| Armature winding temperature rise limit | θ max | °C | 130 | 130 | 130 | 130 | 130 | 130 | 130 | 130 | 130 | 130 |
| Weight (motor only) | — | kg | 1.1 | 1.5 | 2.0 | 3.0 | 7 | 11 | 20 | 31 | 42 | 55 |
| Armature insulation class | — | — | Class F | | | | | | | | | |

2. Motor

Low inertia AC servomotor data sheet (2000rpm/3000rpm)

| Item | Symbol | Unit | HA50LC-S HA50LC-TS | | HA100LC-S HA100LC-TS | | HA150LC-S HA150LC-TS | | HA200LC-S | | HA300LC-S | | HA500LC-S | | | | | | | | | | | | | |
|---|------------------------------------|-------------------------------------|-----------------------|-------|-------------------------|-------|-------------------------|-------|-----------|----|-----------|------|------------------------------|----------------|----------------|----------------|----------------|----------------|----------------|----------------|-----------------|----------------|-------|--------|--|--|
| | | | Pr | Tr | Ir | Ts | Ls | Tps | Ip | Qp | ap | Nmax | GD ² _M | J _M | R _a | L _a | K _E | K _T | t _e | t _m | t _{th} | T _F | θ max | Weight | | |
| Continuous Characteristics | Nominal output | P _R | kW | 0.5 | 1.0 | 1.5 | 2.0 | 3.0 | 5.0 | | | | | | | | | | | | | | | | | |
| | Output torque | T _R | N·m | 2.39 | 4.78 | 7.16 | 9.55 | 14.3 | 23.8 | | | | | | | | | | | | | | | | | |
| | Input current | I _R | A | 3.4 | 6.8 | 9.5 | 13 | 16 | 28 | | | | | | | | | | | | | | | | | |
| Stall state | Output torque | T _S | N·m | 2.94 | 5.88 | 8.83 | 13.7 | 22.6 | 37.3 | | | | | | | | | | | | | | | | | |
| | Input current | L _S | A | 4 | 8 | 11.5 | 18.2 | 25 | 44 | | | | | | | | | | | | | | | | | |
| Instantaneous Characteristics | Instantaneous torque | T _{PS} | N·m | 14.7 | 29.4 | 44.1 | 68.6 | 112.7 | 186 | | | | | | | | | | | | | | | | | |
| | Instantaneous current | I _P | A | 20 | 40 | 57.5 | 91 | 125 | 220 | | | | | | | | | | | | | | | | | |
| | Instantaneous power rate | Q _P | kW/sec | 788 | 1575 | 2362 | 2401 | 4320 | 3931 | | | | | | | | | | | | | | | | | |
| | Instantaneous angular acceleration | a _P | rad/sec ² | 53571 | 53571 | 53571 | 35000 | 36333 | 21111 | | | | | | | | | | | | | | | | | |
| Rated speed | N _{max} | r/min | 2000 | | | | | | | | | | | | | | | | | | | | | | | |
| Rotor GD ² | GD ² _M | x10 ⁻⁴ kg·m ² | 11 | 22 | 33 | 78.4 | 117.6 | 352.8 | | | | | | | | | | | | | | | | | | |
| Rotor inertia | J _M | x10 ⁻⁴ kg·m ² | 2.75 | 5.49 | 8.24 | 19.6 | 29.4 | 88.3 | | | | | | | | | | | | | | | | | | |
| Armature resistance (one phase, 20°C) | R _a | Ω | 1.36 | 0.484 | 0.29 | 0.143 | 0.112 | 0.041 | | | | | | | | | | | | | | | | | | |
| Armature inductance (one phase) | L _a | mH | 7.3 | 3.4 | 3.4 | 1.43 | 1.37 | 0.74 | | | | | | | | | | | | | | | | | | |
| Induced voltage constant (one phase, 20°C) | K _E | mV/rpm±10% (rms) | 27 | 26 | 27 | 26.5 | 32 | 30 | | | | | | | | | | | | | | | | | | |
| Torque constant | K _T | N·m/A±10% | 0.76 | 0.75 | 0.77 | 0.76 | 0.91 | 0.85 | | | | | | | | | | | | | | | | | | |
| Electrical time constant | t _e | msec | 5.4 | 7.0 | 8.3 | 10 | 12.3 | 18 | | | | | | | | | | | | | | | | | | |
| Mechanical time constant | t _m | msec | 1.9 | 1.4 | 1.2 | 1.5 | 1.2 | 1.5 | | | | | | | | | | | | | | | | | | |
| Thermal time constant | t _{th} | min | 40 | 45 | 45 | 60 | 65 | 65 | | | | | | | | | | | | | | | | | | |
| Static frictional torque | T _F | N·m | 0.108 | 0.157 | 0.206 | 0.294 | 0.392 | 0.490 | | | | | | | | | | | | | | | | | | |
| Armature winding temperature rise limit | θ max | °C | 130 | | | | | | | | | | | | | | | | | | | | | | | |
| Weight | — | kg | 6.5 | 9.5 | 12.5 | 16 | 22 | 35 | | | | | | | | | | | | | | | | | | |

The same characteristics apply to the HA□□NLC motor.

2. Motor

Low inertia AC servomotor data sheet (2000rpm/3000rpm)

| Item | Symbol | Unit | HA-LH11K2-S1 | HA-LH15K2-S1 | HA53LC-S HA53LC-TS | HA103LC-S HA103LC-TS | HA153LC-S HA153LC-TS | HA203LC-S | HA303LC-S | HA503LC-S | |
|--|----------------|------------------------------------|--------------|--------------|-----------------------|-------------------------|-------------------------|-----------|-----------|-----------|--|
| Nominal output | P_R | kW | 11.0 | 15.0 | 0.5 | 1.0 | 1.5 | 2.0 | 3.0 | 5.0 | |
| | T_R | N·m | 52.5 | 71.6 | 1.60 | 3.19 | 4.77 | 6.36 | 9.55 | 16.0 | |
| Rated speed Continuous Characteristics | I_R | A | 68.0 | 78.0 | 3.5 | 6.5 | 9.6 | 11.0 | 15.2 | 26.0 | |
| | T_S | N·m | 70.6 | 91.7 | 2.94 | 5.88 | 8.82 | 13.7 | 22.5 | 37.3 | |
| Stall state | L_S | A | 84.0 | 100.0 | 5.8 | 11.0 | 16.2 | 21 | 32 | 54 | |
| | T_{PS} | N·m | 353 | 490 | 14.7 | 29.4 | 44.1 | 68.6 | 112.7 | 186 | |
| Maximum characteristics in stall state | I_P | A | 420 | 500 | 29 | 55 | 81 | 105 | 160 | 270 | |
| | Q_P | kW/sec | 235 | 177 | 788 | 1575 | 2362 | 2401 | 4320 | 3930 | |
| Instantaneous Characteristics | a_P | rad/sec ² | 30000 | 16692 | 53571 | 53571 | 53571 | 35000 | 38333 | 21111 | |
| | N_{max} | r/min | 2000 | | | | | | | | |
| Rated speed | | | 3000 | | | | | | | | |
| Rotor GD^2 | GD^2_M | $\times 10^{-4}$ kg·m ² | 470 | 1160 | 11 | 22 | 33 | 78.4 | 117.6 | 352.8 | |
| Rotor inertia | J_M | $\times 10^{-4}$ kg·m ² | 118.0 | 290.0 | 2.7 | 5.5 | 8.2 | 19.6 | 29.4 | 88.3 | |
| Armature resistance (one phase, 20°C) | R_a | Ω | 0.03 | 0.026 | 0.6 | 0.25 | 0.142 | 0.11 | 0.066 | 0.0289 | |
| Armature inductance (one phase) | L_a | mH | 0.43 | 0.40 | 3.2 | 1.7 | 1.14 | 1.0 | 0.77 | 0.49 | |
| Induced voltage constant (one phase, 20°C) | K_E | mV/rpm $\pm 10\%$ (rms) | 29.6 | 34.3 | 18.5 | 19.8 | 20.0 | 24.2 | 25.2 | 25.5 | |
| Torque constant | K_T | N·m/A $\pm 10\%$ | 0.84 | 0.98 | 0.53 | 0.57 | 0.57 | 0.69 | 0.72 | 0.73 | |
| Electrical time constant | t_e | msec | 14.4 | 15.6 | 5.4 | 6.8 | 8.1 | 9.1 | 11.7 | 17.0 | |
| Mechanical time constant | t_m | msec | 1.6 | 2.32 | 1.8 | 1.3 | 1.1 | 1.4 | 1.1 | 1.5 | |
| Thermal time constant | t_{th} | min | 30 | 30 | 40 | 45 | 45 | 60 | 65 | 65 | |
| Static frictional torque | T_F | N·m | 0.412 | 0.539 | 0.108 | 0.157 | 0.206 | 0.294 | 0.392 | 0.490 | |
| Armature winding temperature rise limit | θ_{max} | °C | 130 | | | | | | | | |
| Weight | — | kg | 70 | 108 | 6.5 | 9.5 | 12.5 | 16 | 22 | 35 | |

The same characteristics apply to the HA□□NLC motor.

2. Motor

(2) Torque-speed characteristic

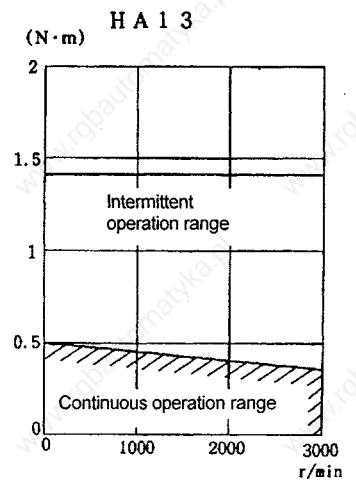
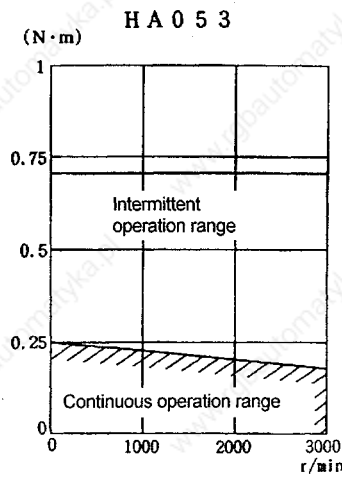
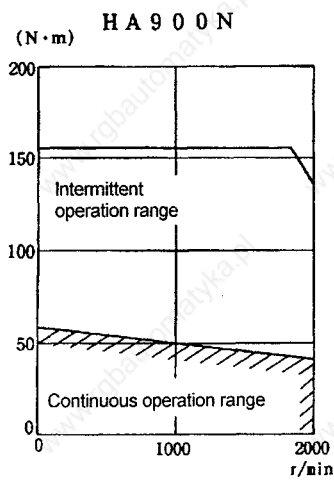
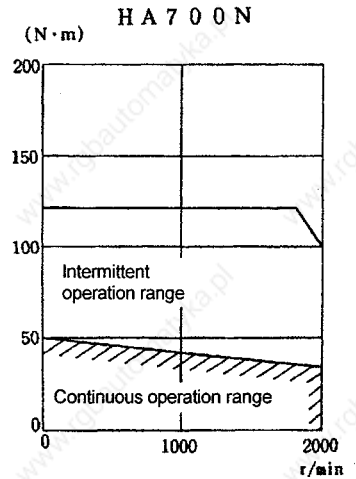
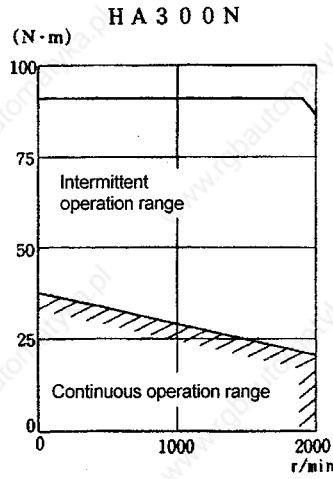
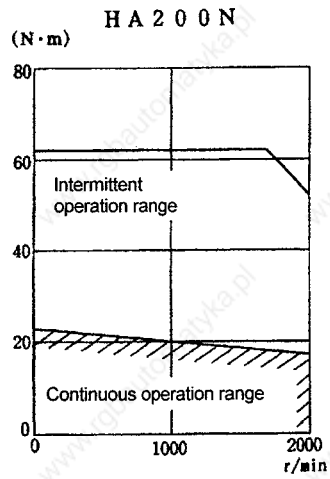
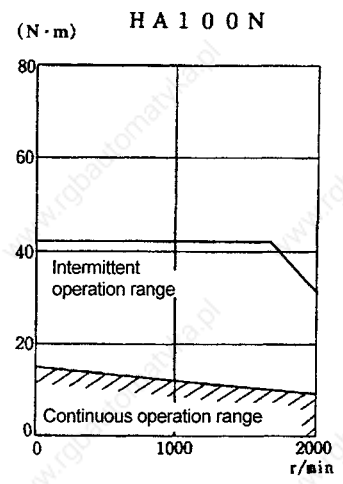
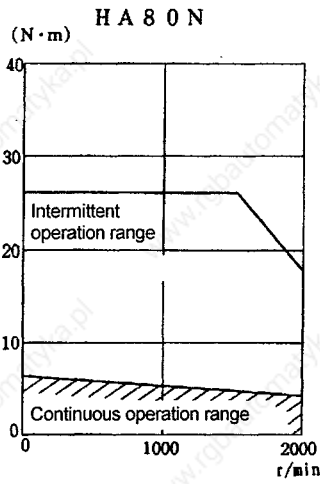
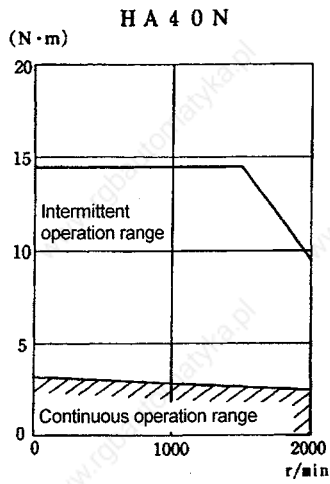

* The upper graphs show the data for the input voltage of 200VAC.

2. Motor

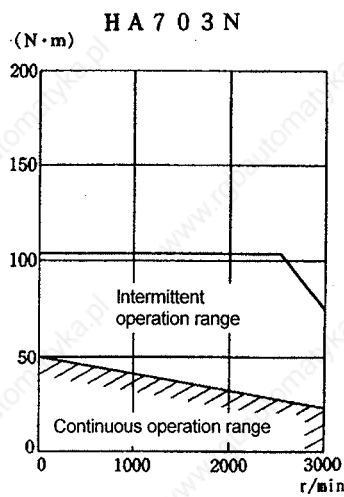
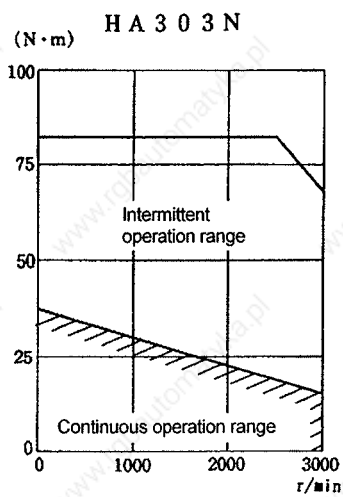
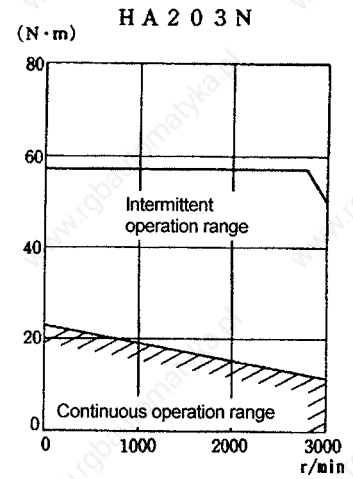
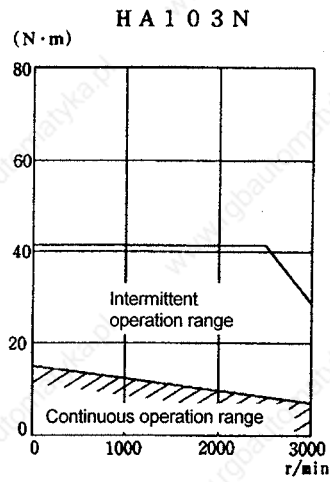
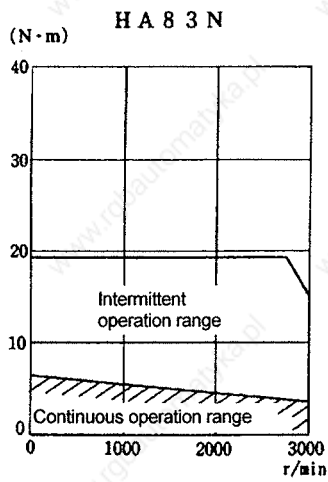
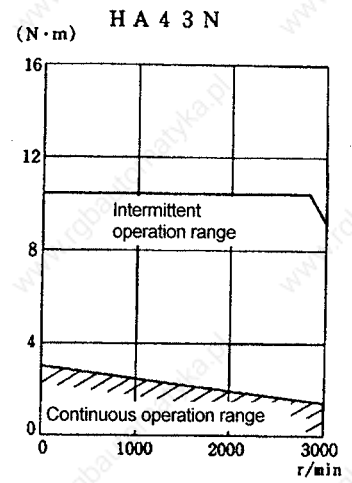
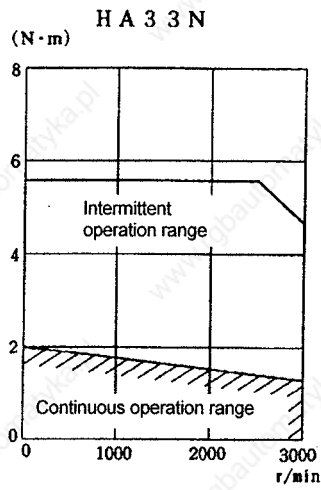
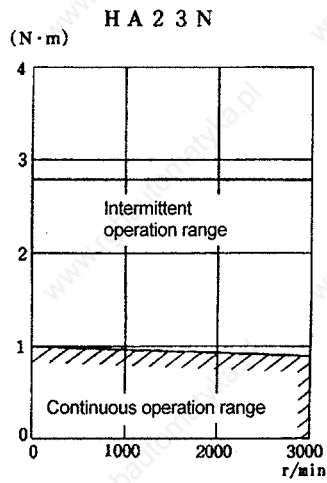

* The upper graphs show the data for the input voltage of 200VAC.

2. Motor

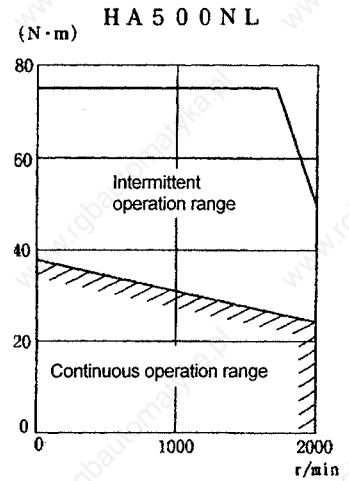
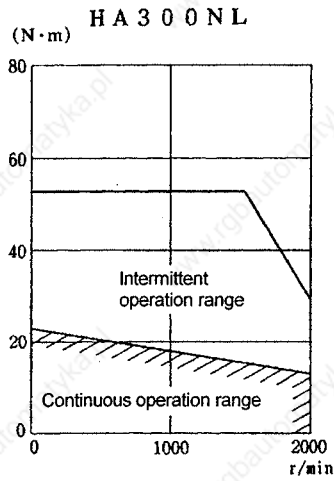
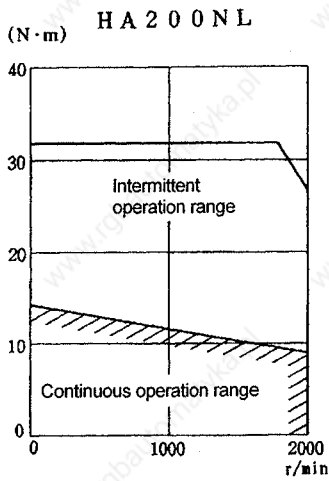
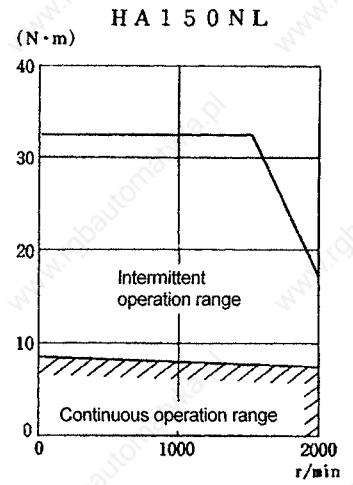
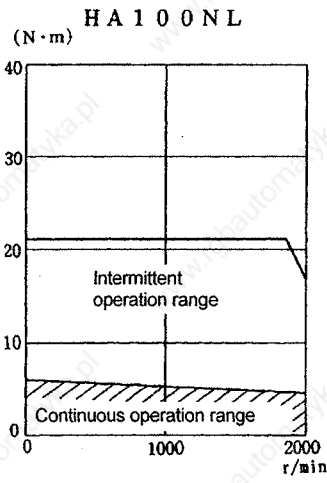
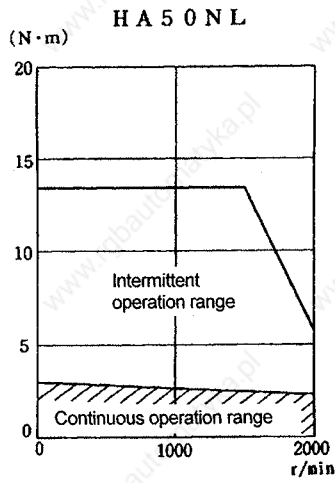

* The upper graphs show the data for the input voltage of 200VAC.

2. Motor

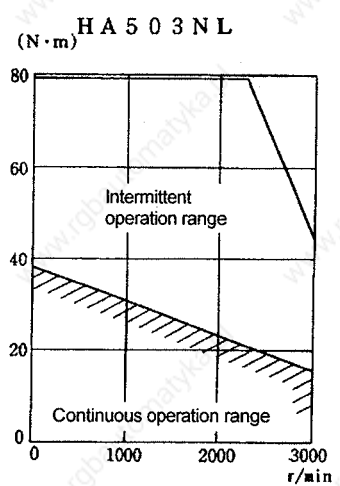
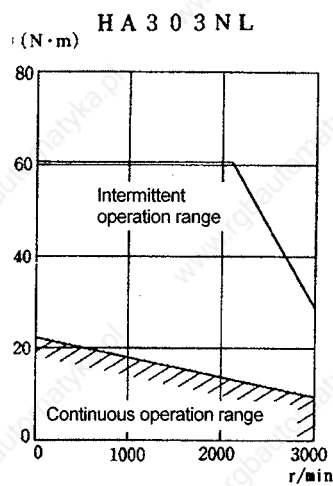
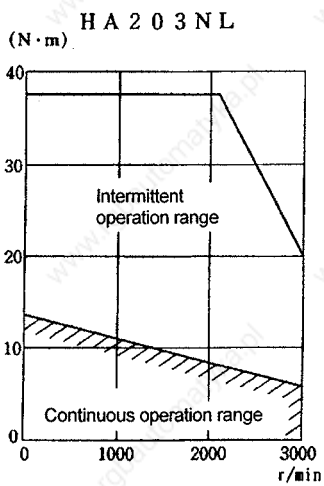
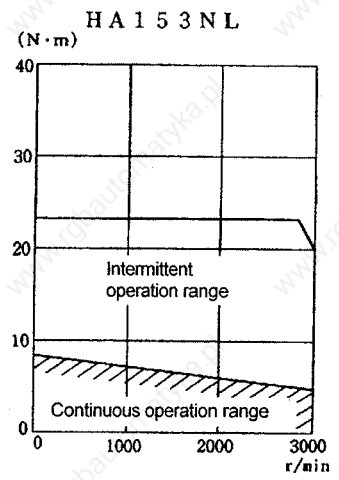
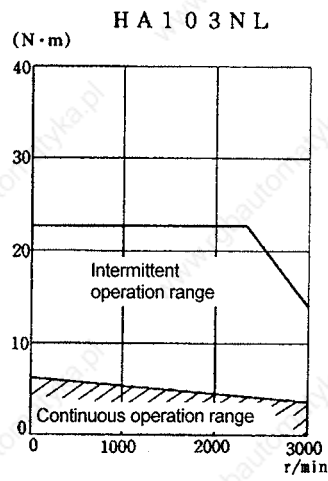
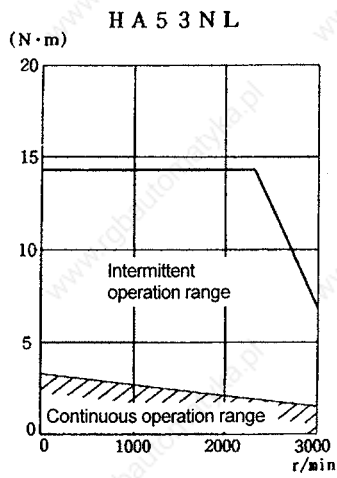

* The upper graphs show the data for the input voltage of 200VAC.

2. Motor

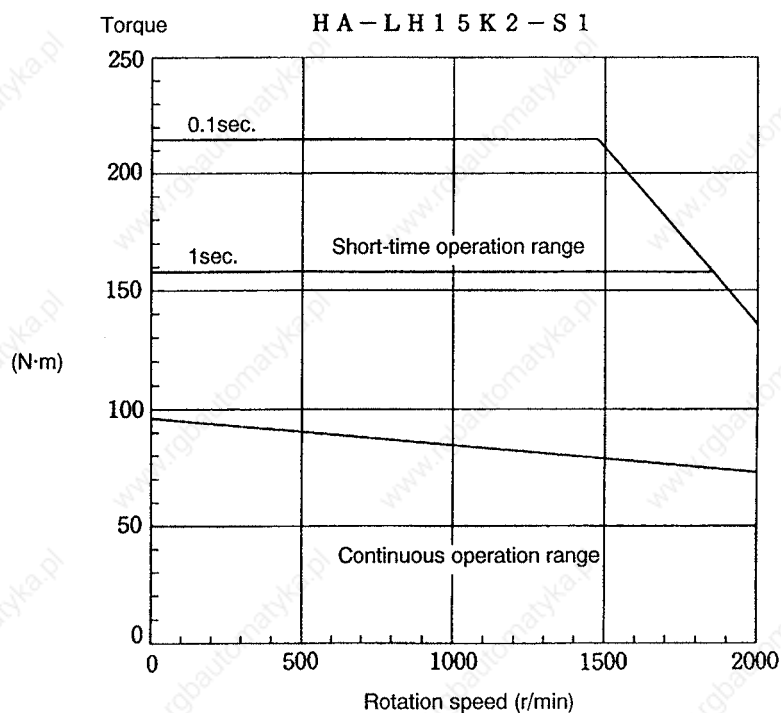
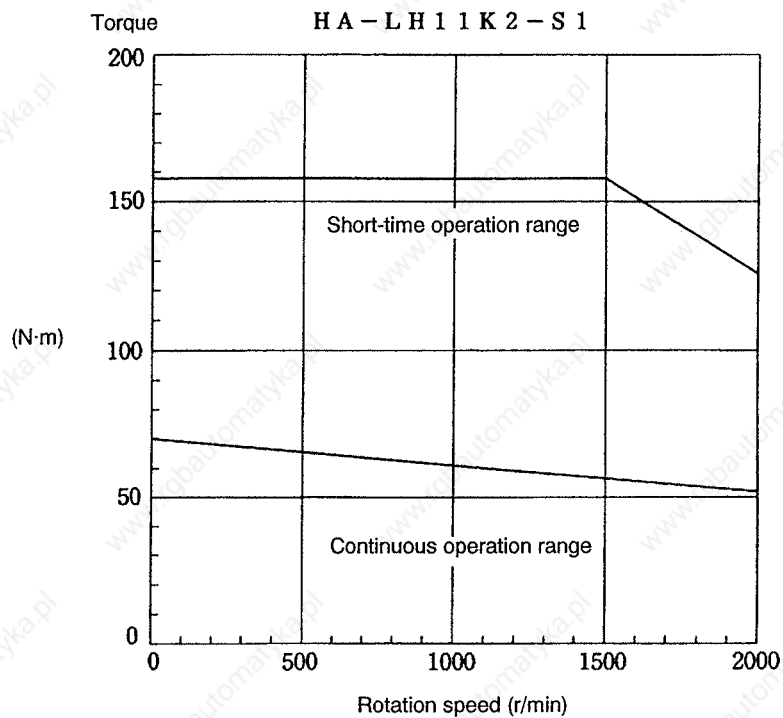

When using a combination of the HA-LH15K2-S1 and V1-150, the short-time operation range is further subdivided by the operation time.

Note) The above torque characteristics are for a 200V power voltage.

These characteristics are not guaranteed when the power voltage drops.

2. Motor

(3) Duty drive characteristic

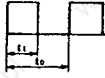

$$\text{Duty percent} = \frac{t_1}{t_0} \times 100 (\%)$$

t_1 = On time (min.)

These characteristics are limited by the servo amplifier.

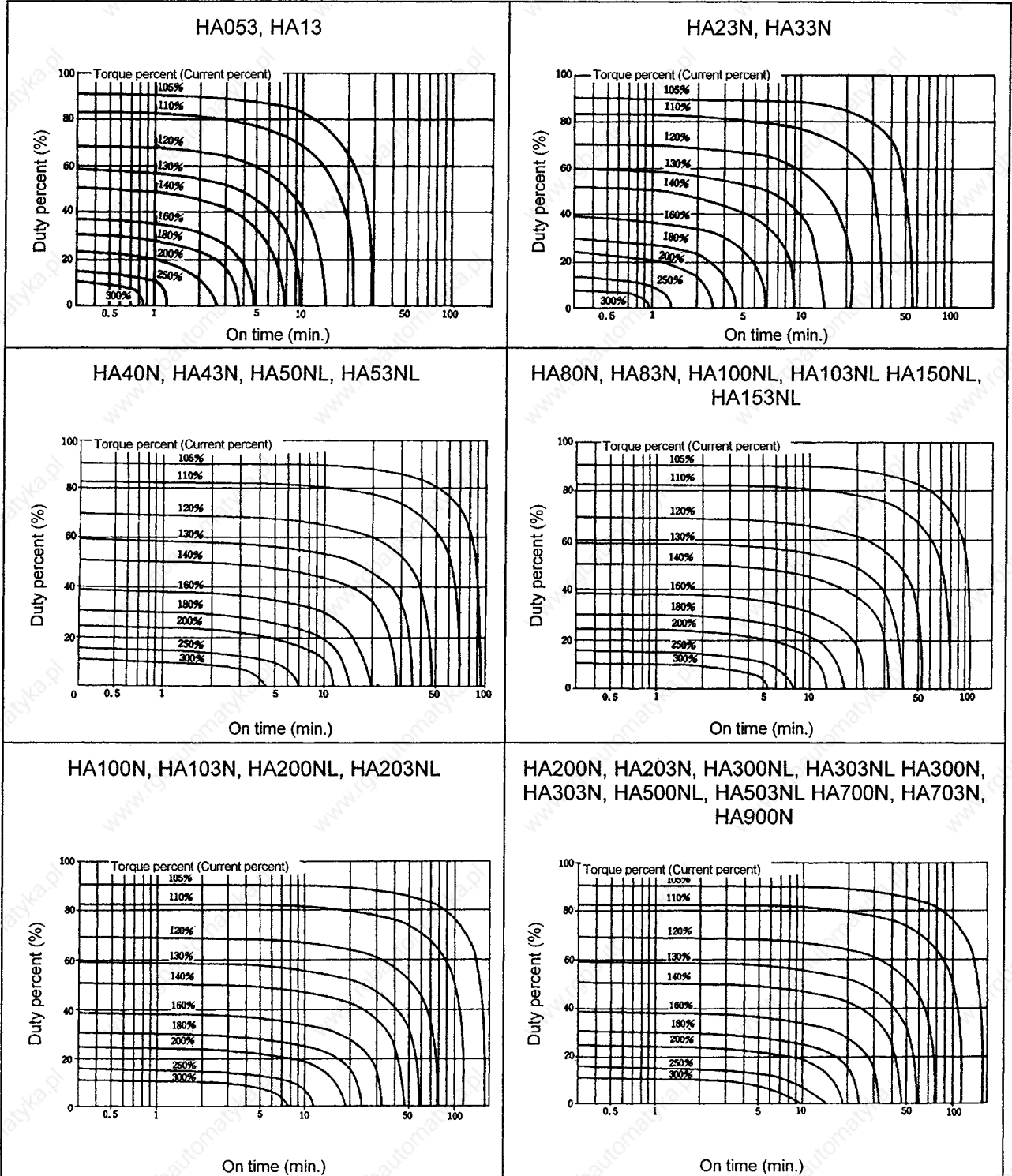

2. Motor

2.7 Motor connection



WARNING

Always insulate the connection section of the power supply terminal. Failure to do so could lead to electric shocks.



CAUTION



Do not directly connect commercial power supply to the servomotor. Doing so could lead to faults.

1. Always match the power lead phases (A, B, C) and the amplifier output terminal (U, V, W) phases.
2. Application of commercial power supply to the motor terminals (U, V, W) could cause the motor to demagnetize or burn.
The commercial power can be connected only to the servo amplifier output terminals (U, V, W).
3. Always ground with the grounding terminal E. Connect to the grounding terminal of the servo amplifier, and ground to the earth with the grounding plate in the control panel. (Refer to the Servo and Spindle System Configuration Section 4.)
4. Supply 24VDC (user-prepared, refer to 2.8 (2) Magnetic brake characteristics for the current capacity) to the brake lead of the motor with magnetic brakes.
The power supply VDD (24VDC) in the servo amplifier cannot be used.

(1) Cannon plugs to be used

| Motor model | Motor side connector | Cannon plug to be used | | | | | | | | | | | | | | |
|---|----------------------|---|---------|-----------|---|-------------------|---|-----|---|-----|---|-------------|---|---|---|---|
| HA053C HA13C HA23NC HA33NC | CE05-2A18-12P | MS3108B18 12S or MS3106B18 12S (Straight type) <table border="1" style="float: right;"> <thead> <tr> <th>Pin No.</th> <th>Lead side</th> </tr> </thead> <tbody> <tr> <td>A</td> <td>U } Motor winding</td> </tr> <tr> <td>B</td> <td>V }</td> </tr> <tr> <td>C</td> <td>W }</td> </tr> <tr> <td>D</td> <td>⊕ Grounding</td> </tr> <tr> <td>E</td> <td>—</td> </tr> <tr> <td>F</td> <td>—</td> </tr> </tbody> </table> | Pin No. | Lead side | A | U } Motor winding | B | V } | C | W } | D | ⊕ Grounding | E | — | F | — |
| Pin No. | Lead side | | | | | | | | | | | | | | | |
| A | U } Motor winding | | | | | | | | | | | | | | | |
| B | V } | | | | | | | | | | | | | | | |
| C | W } | | | | | | | | | | | | | | | |
| D | ⊕ Grounding | | | | | | | | | | | | | | | |
| E | — | | | | | | | | | | | | | | | |
| F | — | | | | | | | | | | | | | | | |
| HA40NC HA43NC HA80NC HA83NC HA50NLC HA100NLC HA150NLC HA53NLC HA103NLC HA153NLC | CE05-2A22-23P | MS3108B22 23S or MS3106B22 23S (Straight type) <table border="1" style="float: right;"> <thead> <tr> <th>Pin No.</th> <th>Lead side</th> </tr> </thead> <tbody> <tr> <td>A</td> <td>U } Motor winding</td> </tr> <tr> <td>B</td> <td>V }</td> </tr> <tr> <td>C</td> <td>W }</td> </tr> <tr> <td>D</td> <td>⊕ Grounding</td> </tr> <tr> <td>E</td> <td>—</td> </tr> <tr> <td>F</td> <td>—</td> </tr> </tbody> </table> | Pin No. | Lead side | A | U } Motor winding | B | V } | C | W } | D | ⊕ Grounding | E | — | F | — |
| Pin No. | Lead side | | | | | | | | | | | | | | | |
| A | U } Motor winding | | | | | | | | | | | | | | | |
| B | V } | | | | | | | | | | | | | | | |
| C | W } | | | | | | | | | | | | | | | |
| D | ⊕ Grounding | | | | | | | | | | | | | | | |
| E | — | | | | | | | | | | | | | | | |
| F | — | | | | | | | | | | | | | | | |
| HA100NC HA200NC HA300NC HA103NC HA203NC HA200NLC HA300NLC HA500NLC HA203NLC HA303NLC | CE05-2A24-10P | MS3108B24 10S or MS3106B24 10S <table border="1" style="float: right;"> <thead> <tr> <th>Pin No.</th> <th>Lead side</th> </tr> </thead> <tbody> <tr> <td>A</td> <td>U } Motor winding</td> </tr> <tr> <td>B</td> <td>V }</td> </tr> <tr> <td>C</td> <td>W }</td> </tr> <tr> <td>D</td> <td>⊕ Grounding</td> </tr> <tr> <td>E</td> <td>—</td> </tr> <tr> <td>F</td> <td>—</td> </tr> </tbody> </table> | Pin No. | Lead side | A | U } Motor winding | B | V } | C | W } | D | ⊕ Grounding | E | — | F | — |
| Pin No. | Lead side | | | | | | | | | | | | | | | |
| A | U } Motor winding | | | | | | | | | | | | | | | |
| B | V } | | | | | | | | | | | | | | | |
| C | W } | | | | | | | | | | | | | | | |
| D | ⊕ Grounding | | | | | | | | | | | | | | | |
| E | — | | | | | | | | | | | | | | | |
| F | — | | | | | | | | | | | | | | | |

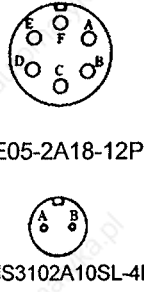
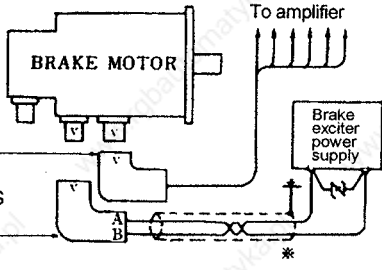
2. Motor

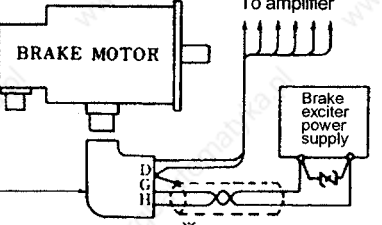
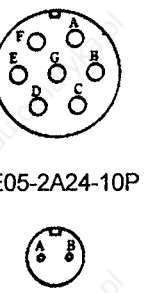
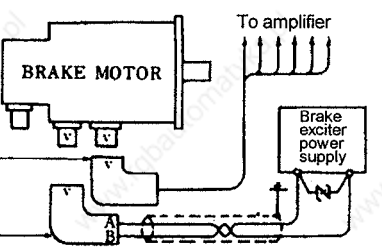
| Motor model | Motor side connector | Cannon plug to be used | | | | | | | | | | | | | | | | | | | | | | | | | | | | |
|--|--|---|---|---------|-----------|--|---|---|-----------------|---|---|---|---|---|---|-----------|---|--|--|---|--|--|---------|-----------|---------|---|--|---------|---|--|
| HA053CB HA13CB HA23NCB HA33NCB |  CE05-2A18-12P H/MS3102A10SL-4P | MS3108B18 12S or MS3106B18 12S (Straight type) MS3108B10SL 4S or MS3106B10SL 4S (Straight type) |  <table border="1" style="width: 100%; border-collapse: collapse;"> <tr> <th style="width: 15%;">Pin No.</th> <th style="width: 15%;">Lead side</th> <th></th> </tr> <tr> <td>A</td> <td>U</td> <td rowspan="3">} Motor winding</td> </tr> <tr> <td>B</td> <td>V</td> </tr> <tr> <td>C</td> <td>W</td> </tr> <tr> <td>D</td> <td>⊕</td> <td>Grounding</td> </tr> <tr> <td>E</td> <td></td> <td></td> </tr> <tr> <td>F</td> <td></td> <td></td> </tr> </table> <table border="1" style="width: 100%; border-collapse: collapse;"> <tr> <th style="width: 15%;">Pin No.</th> <th style="width: 15%;">Lead side</th> <th></th> </tr> <tr> <td>A</td> <td></td> <td rowspan="2">} Brake</td> </tr> <tr> <td>B</td> <td></td> </tr> </table> | Pin No. | Lead side | | A | U | } Motor winding | B | V | C | W | D | ⊕ | Grounding | E | | | F | | | Pin No. | Lead side | | A | | } Brake | B | |
| | | Pin No. | Lead side | | | | | | | | | | | | | | | | | | | | | | | | | | | |
| A | U | } Motor winding | | | | | | | | | | | | | | | | | | | | | | | | | | | | |
| B | V | | | | | | | | | | | | | | | | | | | | | | | | | | | | | |
| C | W | | | | | | | | | | | | | | | | | | | | | | | | | | | | | |
| D | ⊕ | Grounding | | | | | | | | | | | | | | | | | | | | | | | | | | | | |
| E | | | | | | | | | | | | | | | | | | | | | | | | | | | | | | |
| F | | | | | | | | | | | | | | | | | | | | | | | | | | | | | | |
| Pin No. | Lead side | | | | | | | | | | | | | | | | | | | | | | | | | | | | | |
| A | | } Brake | | | | | | | | | | | | | | | | | | | | | | | | | | | | |
| B | | | | | | | | | | | | | | | | | | | | | | | | | | | | | | |
| HA40NCB HA43NCB HA80NCB HA83NCB |  CE05-2A22-23P H/MS3102A10SL-4P | * Indicates "CD cut". MS3108B22-23S or MS3106B22-23S (Straight type) |  <table border="1" style="width: 100%; border-collapse: collapse;"> <tr> <th style="width: 15%;">Pin No.</th> <th style="width: 15%;">Lead side</th> <th></th> </tr> <tr> <td>A</td> <td>U</td> <td rowspan="3">} Motor winding</td> </tr> <tr> <td>B</td> <td>V</td> </tr> <tr> <td>C</td> <td>W</td> </tr> <tr> <td>D</td> <td>⊕</td> <td>Grounding</td> </tr> <tr> <td>E</td> <td></td> <td></td> </tr> <tr> <td>F</td> <td></td> <td></td> </tr> <tr> <td>G</td> <td></td> <td rowspan="2">} Brake</td> </tr> <tr> <td>H</td> <td></td> </tr> </table> | Pin No. | Lead side | | A | U | } Motor winding | B | V | C | W | D | ⊕ | Grounding | E | | | F | | | G | | } Brake | H | | | | |
| | | Pin No. | Lead side | | | | | | | | | | | | | | | | | | | | | | | | | | | |
| A | U | } Motor winding | | | | | | | | | | | | | | | | | | | | | | | | | | | | |
| B | V | | | | | | | | | | | | | | | | | | | | | | | | | | | | | |
| C | W | | | | | | | | | | | | | | | | | | | | | | | | | | | | | |
| D | ⊕ | Grounding | | | | | | | | | | | | | | | | | | | | | | | | | | | | |
| E | | | | | | | | | | | | | | | | | | | | | | | | | | | | | | |
| F | | | | | | | | | | | | | | | | | | | | | | | | | | | | | | |
| G | | } Brake | | | | | | | | | | | | | | | | | | | | | | | | | | | | |
| H | | | | | | | | | | | | | | | | | | | | | | | | | | | | | | |
| HA100NCB HA200NCB HA300NCB HA103NCB HA203NCB |  CE05-2A24-10P H/MS3102A10SL-4P | * Indicates "CD cut". MS3108B24-10S or MS3106B24-10S (Straight type) MS3108B10SL-4S or MS3106B10SL-4S (Straight type) |  <table border="1" style="width: 100%; border-collapse: collapse;"> <tr> <th style="width: 15%;">Pin No.</th> <th style="width: 15%;">Lead side</th> <th></th> </tr> <tr> <td>A</td> <td>U</td> <td rowspan="3">} Motor winding</td> </tr> <tr> <td>B</td> <td>V</td> </tr> <tr> <td>C</td> <td>W</td> </tr> <tr> <td>D</td> <td>⊕</td> <td>Grounding</td> </tr> <tr> <td>E</td> <td></td> <td></td> </tr> <tr> <td>F</td> <td></td> <td></td> </tr> </table> <table border="1" style="width: 100%; border-collapse: collapse;"> <tr> <th style="width: 15%;">Pin No.</th> <th style="width: 15%;">Lead side</th> <th></th> </tr> <tr> <td>A</td> <td></td> <td rowspan="2">} Brake</td> </tr> <tr> <td>B</td> <td></td> </tr> </table> | Pin No. | Lead side | | A | U | } Motor winding | B | V | C | W | D | ⊕ | Grounding | E | | | F | | | Pin No. | Lead side | | A | | } Brake | B | |
| | | Pin No. | Lead side | | | | | | | | | | | | | | | | | | | | | | | | | | | |
| A | U | } Motor winding | | | | | | | | | | | | | | | | | | | | | | | | | | | | |
| B | V | | | | | | | | | | | | | | | | | | | | | | | | | | | | | |
| C | W | | | | | | | | | | | | | | | | | | | | | | | | | | | | | |
| D | ⊕ | Grounding | | | | | | | | | | | | | | | | | | | | | | | | | | | | |
| E | | | | | | | | | | | | | | | | | | | | | | | | | | | | | | |
| F | | | | | | | | | | | | | | | | | | | | | | | | | | | | | | |
| Pin No. | Lead side | | | | | | | | | | | | | | | | | | | | | | | | | | | | | |
| A | | } Brake | | | | | | | | | | | | | | | | | | | | | | | | | | | | |
| B | | | | | | | | | | | | | | | | | | | | | | | | | | | | | | |

- Notes**
- (1) The angle plug (MS3108), straight plug (MS3106), cable clamp (MS3057), and wiring connector should be properly selected.
 - (2) The key position of the cannon connector should be in the direction of the motor flange.
 - (3) Refer to the following table for the European Standards compliant parts.

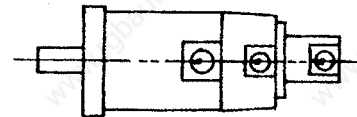

Cannon connector list

| Compatible motor | Cannon | Standard connector | European Standards compliant connector | | |
|------------------|----------|------------------------|--|---------------------|---------------------|
| | Type | Plug (with back shell) | Plug (with back shell) | Cable clamp | Plug (single block) |
| HA053-33 | Straight | MS3106A18-12S | CE05-6A18-12SD-B-BSS | CE3057-10A-□ (D265) | CE05-6A18-12SD-B |
| | Angle | MS3108B18-12S | CE05-8A18-12SD-B-BAS | | — |
| HA40-80 | Straight | MS3106A22-23S | CE05-6A22-23SD-B-BSS | CE3057-12A-□ (D265) | CE05-6A22-23SD-B |
| | Angle | MS3108B22-23S | CE05-8A22-23SD-B-BAS | | — |
| HA100-300 | Straight | MS3106A24-10S | CE05-6A24-10SD-B-BSS | CE3057-16A-□ (D265) | CE05-6A24-10SD-B |
| | Angle | MS3108B24-10S | CE05-8A24-10SD-B-BAS | | — |

* Use the cannon plug single block together with a conduit, etc.

2. Motor

(2) Terminal box type motors

Model applicable : HA700N-SR, HA900N-SR, HA303N-SR, HA703N-SR, HA700NB-SR, HA900NB-SR, HA303NB-SR, HA703NB-SR, HA503NL-SR

Motor terminal box detailed drawing

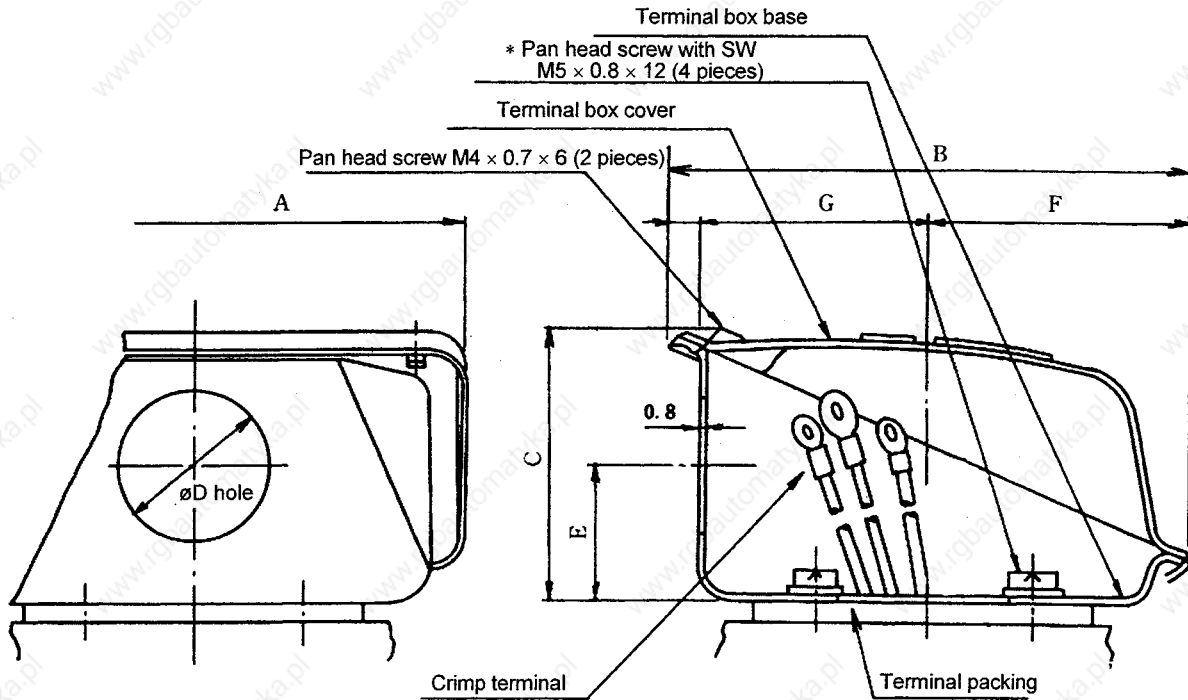

- The direction of the $\varnothing D$ hole of the terminal box can be changed every 90° . However, since the $\varnothing D$ hole is positioned as shown in the outline dimension drawing, remove the screw marked with * when the direction should be changed.
- When a spare part is required due to damage, the part should be ordered from Mitsubishi Electric along with the parts number listed in the drawing.

| Model | Changed dimensions | | | | | | | Model | |
|---|--------------------|-----|----|----|----|----|----|--------------------|-------------------|
| | A | B | C | D | E | F | G | Terminal box cover | Terminal box base |
| HA700N, HA700NB HA900N, HA900NB HA303N, HA303NB HA703N, HA703NB HA503NL | 131 | 144 | 78 | 35 | 37 | 60 | 76 | M953C771H01 | M952B407H20 |

2. Motor

Types of terminal box lead wires

| Servomotor | | | | Servo amplifier | | | | | |
|---|--------------|-----------------------------------|--------------------|-----------------|-----------|-----------|-----------|-----------|----------|
| Lead wire type | | Lead wire crimp terminal | | Terminal | A/B-V1-01 | A/B-V1-10 | A/B-V1-45 | A/B-V1-70 | B-V1-110 |
| Type | Indication | HA700/900 HA503NL HA303/703 | HALH11K HALH15K | | 03 05 | 20 30 | | 90 | 150 |
| Electromagnetic brake (when specified) | Blue Blue | M4 | – | L+ | M6 | M6 | M6 | M6 | M6 |
| Motor windig | U | M6 | M6 | L– | M4 | M4 | M4 | M4 | M4 |
| | V | | | | | | | | |
| | W | | | | | | | | |
| Motor ground | Note (2) | M5 | M5 | U | M4 | M4 | M5 | M5 | M8 |
| Motor fan | BU | – | M4 | V | | | | | |
| | BU | | | W | | | | | |
| | | | | ⊕ | | | | | |

- Notes**
- (1) For the terminal box type servomotors of special models, pay special attention to the model names.
 - (2) Use one of the screws marked with * in the terminal box detailed drawings as the motor ground.
 - (3) When an electromagnetic brake is provided, a surge absorber can be housed in the motor terminal box. See the installation procedure drawing N109D132.
 - (4) The terminals should be connected as shown in the following figure using the screws listed in the above table.
Each connection section should be insulated by winding several turns of insulation tape around it so that it is securely insulated. When housing the connection sections in the terminal box, take care not to damage the insulation section.

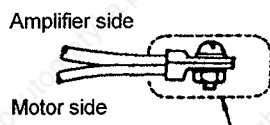

Wind the insulation tape for several turns.

- (5) For the cables to be used, see the following section.

2. Motor

(3) Cables to be used

| Model | U, V, W (Motor main circuit) | Note (2) | Note (3) |
|--|--|--|--|
| | | Grounding wire (Motor ground) | Electromagnetic brake for excitation |
| HA053 HA13 HA23N HA33N | 1.25mm ² (1.25mm ² or less) | 1.25mm ² (1.25mm ² or less) | 0.5mm ² (1.25mm ² or less) |
| HA40N HA43N | 2mm ² or more (3.5mm ² or less) | 2mm ² or more (3.5mm ² or less) | 0.5mm ² or more (3.5mm ² or less) |
| HA80N HA83N | 2mm ² or more (3.5mm ² or less) | 2mm ² or more (3.5mm ² or less) | 0.5mm ² or more (3.5mm ² or less) |
| HA100N | 3.5mm ² or more (8mm ² or less) | 3.5mm ² or more (8mm ² or less) | 0.5mm ² or more (8mm ² or less) |
| HA103N HA200N | 5.5mm ² or more (8mm ² or less) | 5.5mm ² or more (8mm ² or less) | 0.5mm ² or more (8mm ² or less) |
| HA203N HA300N | 5.5mm ² or more (8mm ² or less) | 5.5mm ² or more (8mm ² or less) | 0.5mm ² or more (3.5mm ² or less) |
| HA700N HA900N HA303N HA703N | 8mm ² or more | 8mm ² or more | 0.5mm ² or more (3.5mm ² or less) |
| HA50NLC HA100NLC HA53NLC HA103NLC | 2mm ² or more (3.5mm ² or less) | 2mm ² or more (3.5mm ² or less) | |
| HA150NLC HA153NLC | 2mm ² or more (3.5mm ² or less) | 2mm ² or more (3.5mm ² or less) | |
| HA200NLC HA300NLC HA203NLC HA303NLC | 5.5mm ² or more (8mm ² or less) | 5.5mm ² or more (8mm ² or less) | |
| HA500NLC | 5.5mm ² or more (8mm ² or less) | 5.5mm ² or more (8mm ² or less) | |
| HA503NL | 8mm ² or more | 8mm ² or more | |
| HA-LH11K2 | 14mm ² or more | 14mm ² or more | |
| HA-LH15K2 | 22mm ² or more | 22mm ² or more | |

- Notes** (1) For reference, the cable size in parentheses above represents a restricted value from the soldered cup dimensions of the cannon plug.
 (2) "Internal regulation" for identifying the grounding wire is described as follows:

| |
|---|
| <p>140-14 Green color identification of grounding wire</p> <p>1. A green identification sign shall be placed on any grounding wire for any grounding work except:</p> <ol style="list-style-type: none"> ① when only the grounding wire is connected and it can be easily identified. ② when one conductor in a cable, tough rubber sheathed cable or cord with a multiple number of conductors is used as a grounding wire and when the conductor is a bare wire or has a green and yellow stripe pattern. <p>[Note] When one conductor in a cable, tough rubber sheathed cable or cord with a multiple number of conductors is used as a grounding wire, any other conductor except for one which has a green or greenish yellow stripe pattern cannot be used as a grounding wire.</p> <p>2. If any other conductor except for one with a green or greenish yellow stripe pattern is used as a grounding wire, it is necessary to indicate that the conductor is a ground wire using green tape and the like at the terminal and proper positions.</p> |
|---|

- (3) When the electromagnetic brake works in "DC OFF", use a shielded cable.
 (4) When the motor is used in an application where it travels, select a cable type with high flexibility.
 (5) For crimp terminals connected to the servo amplifiers, see (2).

2.8 Motors with electromagnetic brake

|  CAUTION |
|--|
| <ol style="list-style-type: none"> 1. The axis will not be mechanically held even when the dynamic brakes are used. If the machine could drop when the power fails, use a servomotor with magnetic brakes or provide an external brake mechanism as holding means to prevent dropping. 2. The magnetic brakes are used for holding, and must not be used for normal braking. There may be cases when holding is not possible due to the life or machine structure (when ball screw and servomotor shaft are coupled with a timing belt, etc.). Provide a stop device on the machine side to ensure safety. 3. Use a double circuit configuration so that the magnetic brake operation circuit will activate even with the external emergency stop signal. |

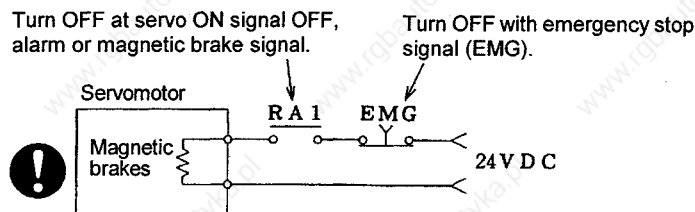

When using the motor with magnetic brakes for double dynamic safety to prevent dropping of the vertical axis or during an emergency stop, note the following cautions.

- ① The brake is a safety brake. The brakes are applied when the power (24VDC) is OFF.
- ② Always turn the servo OFF (SON signal) when applying the brakes.
- ③ When using to prevent dropping of the vertical axis, create a sequence that considers the braking delay time.

(1) Outline of motors with electromagnetic brake

(a) Types

Motors with electromagnetic brakes are a lineup of the HA series. Their specifications are described in the following paragraph.

(b) Applications

When a motor with an electromagnetic brake is used for a vertical feed axis in a machining center, and even if the hydraulic pressure of a hydraulic balancer becomes 0 due to power OFF, the brake prevents the spindle head from dropping. In robots, even if the power is abruptly turned off, this type of motor can prevent the robot body from falling down.

When this type of motor is used for the feed axis of a grinding machine, a dual interlock can be structured along with an emergency stop dynamic brake, thereby preventing collisions and spraying of ground materials.

This motor cannot be used for any other purposes than holding and braking at the time of power failure (in emergency).

(c) Features

- ① Since the electromagnetic brake is a DC excitation type,
 - The brake has a simple mechanism and high reliability.
 - The brake tap selection is not necessary for frequencies of 50Hz and 60Hz.
 - With excitation ON, no rush current and no shock occur.
 - The brake portion is smaller than the motor section.
- ② Since the electromagnetic brake is housed in the motor non-load side, the installation dimensions of this motor type are the same as those of non-brake type motors.
- ③ For electromagnetic brakes, no maintenance inspections are required.
- ④ This motor type can be safely and securely mounted in elevated locations (with eyebolt taps for the HA100NB or larger models).

2. Motor

(2) Characteristics of electromagnetic brakes

The following table lists the characteristics of the hold brakes used in the servomotors with brake.

| Item | Model | HA053B HA13B | HA23NB HA33NB | HA40NB HA43NB HA80NB HA83NB | HA100NB HA103NB HA200NB HA203NB HA300NB HA303NB HA700NB HA703NB HA900NB |
|---|--|--|---|---|---|
| | | (1) Type | Spring type safety brake | | |
| (2) Excitation coil rating (long-term continuous energization is available.) | 24VDC | | | | |
| (3) Excitation coil resistance | Cold state (20°C) | 111Ω | 49Ω | 38Ω | 23Ω |
| | Hot state | 144Ω | 64Ω | 49Ω | 30Ω |
| (4) Attraction current (when the motor is new, approx.) | 0.15A | | | | |
| (5) Drop current | 0.06A | | | | |
| (6) Static frictional torque T _B | 0.39N·m | | | | |
| (7) Inertia moment | GD ² _b (×10 ⁻⁴ kg·m ²) Note 1 | 0.06×10 ⁻⁴ kg·m ² | 0.8×10 ⁻⁴ kg·m ² | 2.7×10 ⁻⁴ kg·m ² | 17×10 ⁻⁴ kg·m ² |
| | (8) Release delay time | 0.03sec | 0.05sec | 0.07sec | 0.10sec |
| (9) Braking delay time t ₂ | AC OFF | 0.1sec | 0.20sec | 0.24sec | 0.27sec |
| | DC OFF | 0.02sec | 0.03sec | 0.04sec | 0.04sec |
| (10) Tolerable braking work amount (Note 2) | E ₁ One braking operation | 5.6J | 49.0J | 294.2J | 980.7J |
| | E ₂ One hour | 55.9J | 490.3J | 2942.0J | 9806.7J |
| (11) Brake life (Note 3) | With load of 5.6J per braking: 30000 times | With load of 49.0J per braking: 30000 times | With load of 294.2J per braking: 30000 times | With load of 980.7J per braking: 30000 times | |
| (12) Tolerable speed | 3000r/min | | | | |
| (13) Spline looseness (calculated value) | 0.25 ~ 2.5° | 0.2 ~ 1.5° | 0.16 ~ 0.57° | 0.10 ~ 0.36° | |

Note 1. GD²_b in the above table(7) is a value to be added to a motor without brake.

Note 2. The braking work amount of the brake is expressed by the following equations. The braking work amount should be less than the tolerable braking work amount in (10) of the above table.

$$E_1 = \frac{1}{2} \cdot \frac{GD_M^2 + GD_L^2}{4} \cdot \left[\frac{2\pi}{60} N_{GO} \right]^2 \times 10^{-4}$$

$$E_2 = \frac{1}{2} \cdot \frac{GD_M^2 + GD_L^2}{4} \cdot \left[\frac{2\pi}{60} N_{GO} \right]^2 \times 10^{-4} \times n = E_1 \cdot n$$

Where

E₁ : Braking work amount in one braking operation (J)

GD_M² : Motor with brake GD² (×10⁻⁴kg·m²) Note 4

GD_L² : Motor shaft conversion load GD² (×10⁻⁴kg·m²)

N_{GO} : Rapid traverse motor speed (r/min)

E₂ : Braking work amount per hour (J)

n : Braking times per hour (times)

Note 3. The brake life is the time from when the brake gap increases due the wear of the brake lining, and the attraction is inhibited (brake opening is not possible).

A life of 30,000 times is equivalent to 5 times/day for 15 years. Thus, when using the brakes exclusively for holding, there is no need to worry about the life.

Note 4. For the value of GD_M², refer to 2.6, "Data sheet."

2. Motor

(3) Using electromagnetic brake

(a) Brake excitation power

- 1) The brake terminals are connected to a cannon connector in any polarity.
The brake terminals are clearly shown on the motor's outline drawing. Do not mistake the brake terminals for another circuit.
- 2) When handling is required for aligning the machine, etc., prepare another 24VDC power and perform the operation while the brake is electrically released.
The reason why a manual release unit is not provided is to prevent workers from forgetting to restore the unit after use.
- 3) Since the system is not provided with a brake excitation power, it should be prepared on the machine side. The brake excitation power should be determined by considering both the voltage fluctuation and the excitation coil temperature so as to securely feed the flowing current. The external output for the brake is mounted on the servo amplifier. For using it, see the following (c).
- 4) The brake excitation power can be turned OFF (brakes applied) with AC OFF or DC OFF.
The "DC OFF" is effective when the braking follow-up time is important.
However, it is necessary to check the contact DC shut-off capacity and occurrence of error signal to NC. Follow these precautions.

Precautions in "DC OFF"

- The contact DC shut-off capacity should be properly provided.
- Use a surge absorber.
- In the cannon connector type, the surge absorber is located far from the switch, therefore shield the cable between the switch and the surge absorber.

- 5) When the cannon plug is connected or disconnected while the brake power is energized, the motor is damaged (the pins of the cannon plug are damaged due to sparks).
- 6) When the brake excitation current does not flow (due to a fuse blowing, contact damage, cable breakage, etc.), turn off the motor's main circuit to prevent the motor from rotating while the brake is activated.

Example of DC OFF using stabilized power

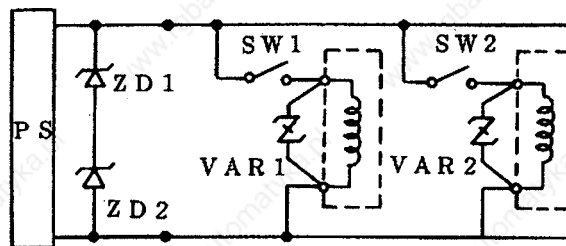

- PS : 24VDC stabilized power
 ZD1, ZD2 : Zener diode (1W, 24V; Mitsubishi: MZ424-A)
 VAR1, VAR2 : Surge absorber (220V; Matsushita Electric Works ERZ-C10DK221)

Example of AC OFF using stabilized power

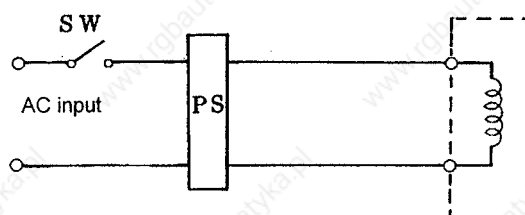

PS : 24VDC stabilized power

2. Motor

Refer to the following table for selecting the wires.

| Motor | Power supply | | |
|---|----------------------|-----------------------|-----------------------|
| | Input voltage AC (V) | Output voltage DC (V) | Output current DC (A) |
| HA053B HA13B | 100 or 200 | 24 | 0.5A or more |
| HA23NB HA33NB | 100 or 200 | 24 | 0.7A or more |
| HA40NB HA43NB HA80NB HA83NB | 100 or 200 | 24 | 0.9A or more |
| HA100NB HA103NB HA200NB HA203NB HA300NB HA303NB HA700NB HA703NB HA900NB | 100 or 200 | 24 | 1.5A or more |

(b) Safety considerations

1) Using timing belt

As shown below on the left, when the HA motor with electromagnetic brake is connected to a load (such as a ball screw) with a timing belt, if the belt is broken, a dangerous situation occurs. Even if the safety coefficient of the belt is increased, the belt may break due to over-tension or cutting chips. In this case, use the method as shown below on the right to improve the safety.

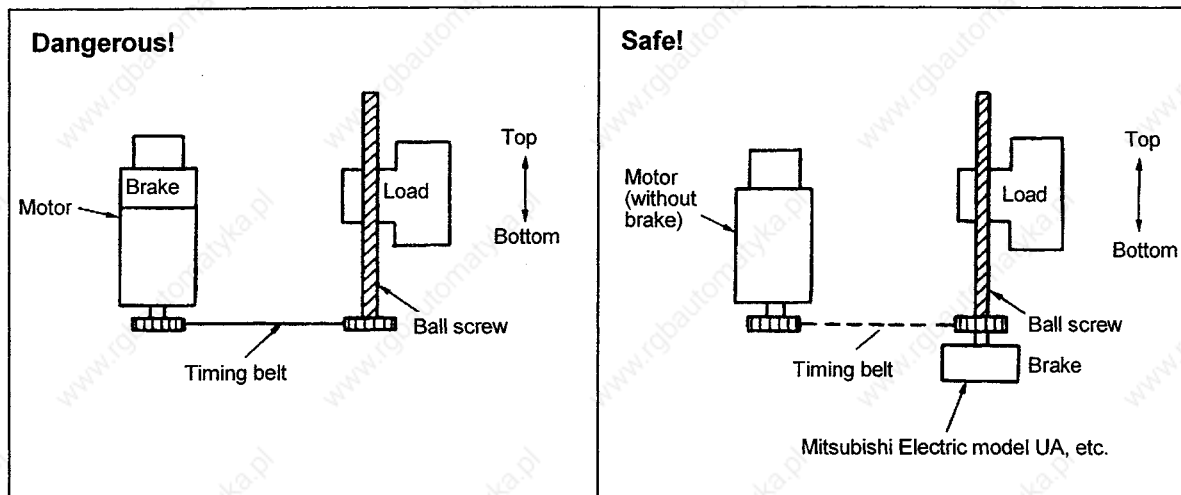

2. Motor

2) Application for grinding machine feed axis

When NC is emergency-stopped, the dynamic brake is activated and the motor stops suddenly, but even if the electromagnetic brake is used along with the dynamic brake, the coasting distance cannot be remarkably shortened.

When considering a failsafe system for the grinding machine, test the coasting distance to determine the limit of the dynamic brake, and then evaluate whether the system is safe or not. In this case, the machine decelerates and stops in the pattern shown in the drawing. The coasting distance in the rapid traverse state, L_{MAX} , is the hatched area in the following drawing, and is calculated by the following equation:

$$L_{MAX} = \frac{F_{Go} \times 10^3}{60} \left(t_1 + t_2 + \frac{t_3}{2} \right) \text{ (mm)}$$

Braking using electromagnetic brake

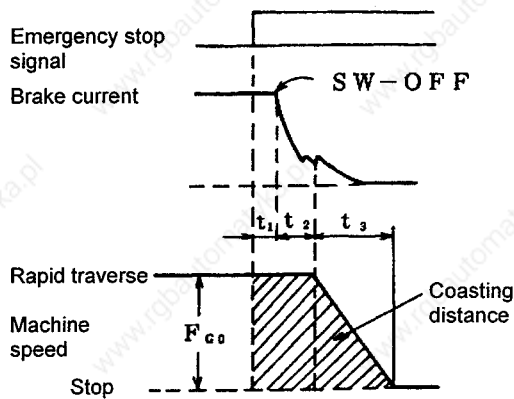

Where

F_{Go} : Machine speed in rapid traverse state (m/min)

t_1 : Delay time in NC (0.05sec)

* t_2 : Electromagnetic braking delay time (sec)

t_3 : $\frac{(GD_M^2 + GD_L^2) N_{Go}}{9.55 \times 10^4 (T_L + 0.8T_B)}$ (sec)

* GD_M^2 : GD^2 of motor with brake ($\times 10^{-4} \text{kg} \cdot \text{m}^2$)

GD_L^2 : GD^2 on load side converted into motor shaft ($\times 10^{-4} \text{kg} \cdot \text{m}^2$)

N_{Go} : Rapid traverse motor shaft (r/min)

T_L : Dynamic friction torque on motor shaft conversion load side (N·m)

* T_B : Static friction torque of electromagnetic brake (N·m)

For the asterisk mark (*), see the data in paragraph 2.8(2).

(c) Precautions for sequence

Although the brake excitation power supply should be prepared by the user, exercise the following precautions:

- 1) When the brake is released (excitation power is ON), make sure that the servo ON state takes place. The following sequence prevents the vertical axis from dropping.

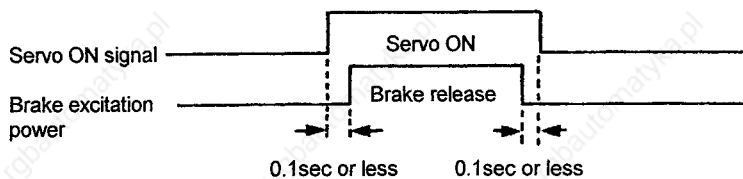

- 2) When the above sequence cannot be formed, use the "DC OFF" of the excitation power to decrease the drop distance of the vertical axis.

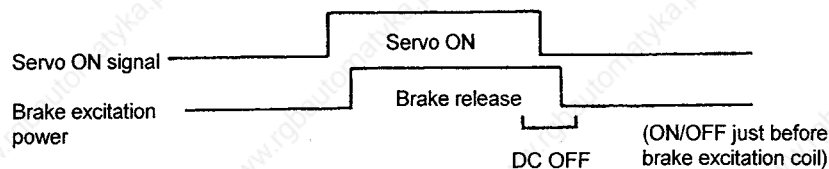

2. Motor

3) In the MDS series, the external output contacts on the servo amplifier can be used.

(Example of external contact use - DC OFF)

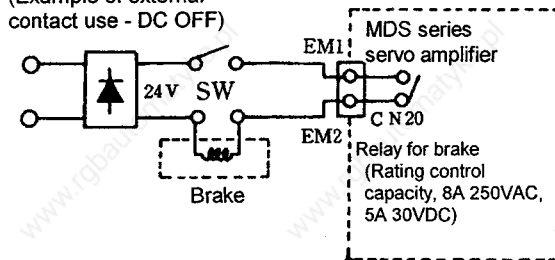

(External output contact sequence)

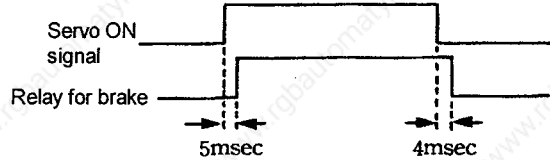

2.9 Motor vibration resistance

| Motor | Direction of vibration | |
|--|-----------------------------|-----------------------------|
| | Axial (X) | Perpendicular to axis (Y) |
| HA053, HA13, HA50L HA23N, HA33N, HA100L HA40N, HA43N, HA150L HA80N, HA83N | 9.8m/s ² (1.0G) | 24.5m/s ² (2.5G) |
| HA100N, HA103N, HA200L HA200N, HA203N, HA300L | 19.6m/s ² (2.0G) | 49.0m/s ² (5.0G) |
| HA300N, HA303N HA700N, HA703N HA500L | 11.8m/s ² (1.2G) | 29.4m/s ² (3.0G) |
| HA900N | 9.8m/s ² (1.0G) | 24.5m/s ² (2.5G) |
| HA-LH11K2, HA-LH15K2 | 9.8m/s ² (1.0G) | 24.5m/s ² (2.5G) |

Conditions

1. In the motor stop state
2. In the installed state
3. No abnormalities occur when the above vibrations are applied for 6 hours at 250Hz (check that there is no resonance point at 250Hz or less).

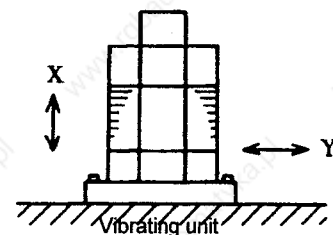

Note (1) Even if the above values are satisfied, for machines with excess vibrations, (turret punch press, press, shearer, etc.), carefully check the looseness of the cannon plug, cable condition, and cable clamps, etc. on the machine side.

2. Motor

2.10 Motor shaft strength

When the AC servomotor is connected to a load, check that the load being applied to the motor shaft does not exceed the values shown in the following table.

Motor shaft end tolerable load

| Model | Tolerable radial weight | Tolerable thrust weight |
|--|--|-------------------------|
| HA053/13 | L = 26 8kg | 5kg |
| HA23N/33N | L = 30 25kg | 15kg |
| HA50L HA40N/43N HA100L HA80N/83N HA150L HA53L HA103L HA153L | Tapered shaft L = 58 40kg Straight shaft L = 55 100kg | 50kg |
| HA200L HA100N HA300L HA103N HA203L HA200N HA303L HA203N HA300N HA303N HA700N HA703N | L = 79 210kg | 100kg |
| HA500L HA900N HA503L, HALH-LH11K2 | L = 85 250kg | 100kg |
| HA-LH15K2 | L = 100 300kg | 100kg |

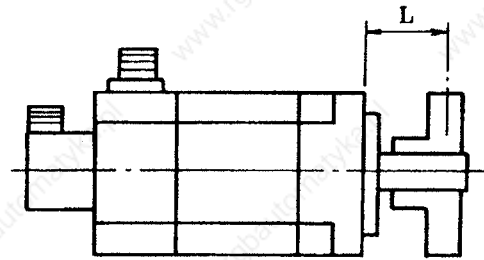

L : Distance between flange installation surface and center of load weight (mm)

- (Note)** 1. The tolerable thrust load indicates that no radial weight of the load is applied. The above tolerable values are the maximum values and are not the continuous tolerable loads. When the motor is connected to the load, the radial weight applied to the motor shaft is calculated as follows.

Direct connection:

Use flexible coupling, and align the core as much as possible. When using highly rigid coupling, further precise core alignment will be required. The radial weight applied to the shaft on which the coupling is used is obtained by the following equation.

$$P = K_R \times \delta$$

Where P : Radial weight (kg)
K_R : Spring constant in radial direction of coupling (kg/mm)
δ : Core deviation (mm)

Gear:

The radial load applied to the axis on which a gear is directly engaged to the motor shaft is obtained by the following equation.

$$P = \frac{1}{980} \cdot \frac{T_{\max}}{\frac{D}{2} \cos \alpha}$$

Where P : Radial weight (kg)
T_{max} : Maximum motor torque (N·m)
D : Gear pitch circle (cm)
α : Gear pressure angle (degree)

When the timing belt is used, obtain the total of the initial tension of the belt and the force by the load torque. For the calculation method, see the related document issued by the timing belt manufacturer.

2. Motor

(Note) 2. Cautions for mounting load (prevention of impact on shaft)

- When using the servomotor with keyway, use the screw hole at the end of the shaft to mount the pulley onto the shaft. When installing, first insert both screw bolts into the screw holes on the shaft, and press them in while tightening the nuts.
- When pulling out the pulley, use a pulley puller.
- When transporting the unit, do not put hands or ropes on the detector cover.
- When assembling, do not tap the shaft end with a hammer, etc.
(The detector could be damaged.)

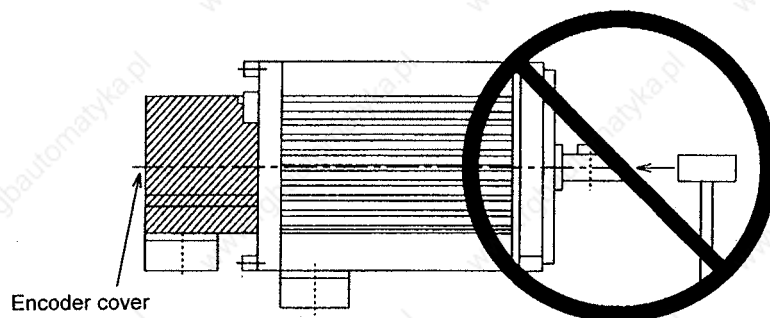

- The direction that the detector is installed on the servomotor cannot be changed.

3. Detectors

3.1 List of model names

(1) Relative position detection type

- OHE 25K-6 : Standard encoder (for motors 500W and higher)
- OHE 25K-85 : Small capacity motor encoder (for 200W and 300W motors)
- OHE 25K-108 : Low inertia motor encoder
- OHE 25K-ET : Ball screw end detection encoder

(2) Absolute position detection type

- OHA 25K-4 : Standard encoder (for motors 500W and higher)
- OHA 25K-85 : Small capacity motor encoder (for 200W and 300W motors)
- OHA 25K-108 : Low inertia motor encoder
- OHA 25K-ET : Ball screw end detection encoder

Refer to section 3.4 when using the serial pulse encoder.

3. Detectors

3.2 Specification

| Class | Type | Model name | Max. speed r/min | Power | Detector output | Output signal usage class |
|---|--|--|--|---------------------------------|---|--|
| Motor shaft end detector | Relative position detection encoder | For standard: OHE 25K-6 For small capacity motor: OHE 25K-85 For low inertia motor: OHE 25K-108 | 3000 | 5VDC +0.25V -0.5V | A, B-phase 2500p/rev | Machine position detection (100,000P/R after multiplying by four) |
| | | | | | Z-phase 1p/rev | Zero point indexing |
| | | | | | U,V,W-phase 2p/rev | Motor polarity detection |
| | Absolute position detection encoder | HA053/13 Motor built-in encoder | 3000 | 5VDC +0.25V -0.5V | A, B-phase 2500p/rev | Machine position detection (10,000P/R after multiplying by four) |
| | | | | | Z-phase 1p/rev | Zero point indexing |
| | | | | | U,V,W-phase 2p/rev | Motor polarity detection |
| Ball screw end detector | Relative position detection encoder | OHE 25K-ET | 3000 | 5VDC +0.25V -0.5V | A, B-phase 2500p/rev | Machine position detection (100,000P/R after multiplying by four) |
| | | | | | Z-phase 1p/rev | Zero point indexing |
| | | | | | A, B-phase 2500p/rev | Machine position detection (100,000P/R after multiplying by four) |
| | Absolute position detection encoder | OHA 25K-ET | 3000 | 5VDC +0.25V -0.5V | Z-phase 1p/rev | Zero point indexing |
| | | | | | Absolute value data | Absolute position detection Max. 32000 rev. |
| | | | | | A, B-phase 2500p/rev | Machine position detection (100,000P/R after multiplying by four) |
| (Reference) Machine end detector | Absolute value linear scale AT41- <input type="text"/> ↑ Scale effective length * Mitsubishi | Max. 50m/min. | 5VDC ±0.5V | A, B-phase | Machine position detection (1μm/P after multiplying by four) | |
| | | | | Z-phase | Zero point indexing (Grid width 10mm) | |
| | | | | Absolute value data 1μm unit | Absolute position detection (Full stroke) | |
| | MP scale system * Mitsubishi Heavy Industries * Product configuration: A/D converter, pre-amplifier (1 to 3-axis integrated) (1 unit/axis) | Max. 30m/min | Single phase 100/110V | A, B-phase | Machine position detection (1μm/P after multiplying by four) | |
| | | | | Z-phase | Zero point indexing (Grid width 2mm) | |
| | | | | | | |
| Note) This must be purchased from the manufacturer. | Other scales Use an incremental scale for the machine end that satisfies the conditions on the right. | | <p>* Use a scale with an A/B phase difference and Z-phase width of 0.1μsec or more at the maximum feed rate. * Use an A, B, Z-phase signal with differential output (RS-422 standard product) for the output signal.</p> | | | |
| | <p>Phase difference</p>  <p>Output circuit</p>  <p>Z-phase</p>  <p>For a scale having multiple Z phases, select the one for which the distance between neighboring Z phases is an integral mm.</p> | | | | | |

3.3 Machine end detector outline drawing

(1) OHE 25K-ET

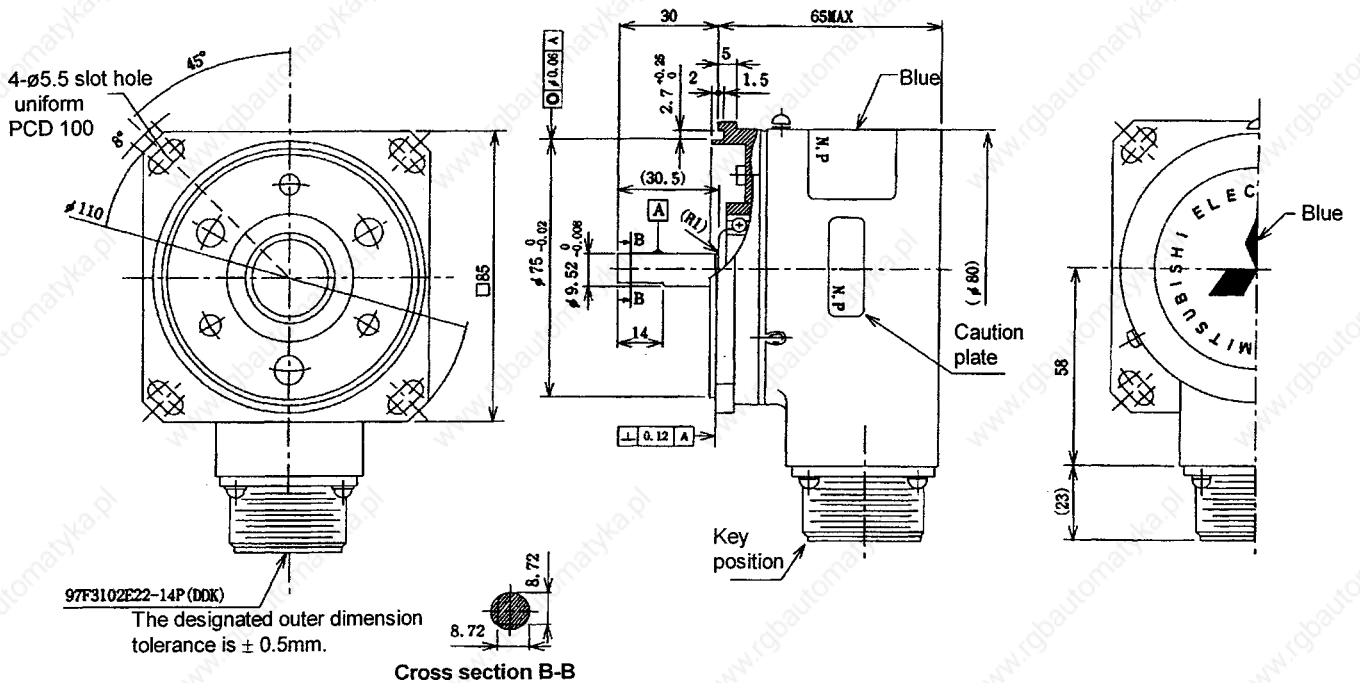

Connector: 97F3102E22-14P (DDK)

| | |
|--------------------------|---|
| Weight | 1.0kg or less |
| Moment of inertia | $0.2 \times 10^{-4} \text{kg} \cdot \text{m}^2$ or less |
| Friction torque | 0.0196N·m or less |
| Thermal relay | Functions at $85 \pm 5^\circ\text{C}$ |

| Pin No. | Function | Pin No. | Function |
|---------|-------------------------|---------|-------------------------|
| A | A-phase signal | K | V-phase signal |
| B | \bar{A} -phase signal | L | \bar{V} -phase signal |
| C | B-phase signal | M | W-phase signal |
| D | \bar{B} -phase signal | N | Case grounding |
| E | NC | P | NC |
| F | Z-phase signal | R | GND |
| G | \bar{Z} -phase signal | S | +5VDC |
| H | U-phase signal | U | \bar{W} -phase signal |
| J | \bar{U} -phase signal | T | Thermal relay |
| | | V | Thermal relay |

Cautions

- * This is an incremental encoder for the ball screw end.
- * The outline dimensions are the same as for the absolute value encoder, and only the nameplate color differs.

3. Detectors

(2) OHA 25K-ET

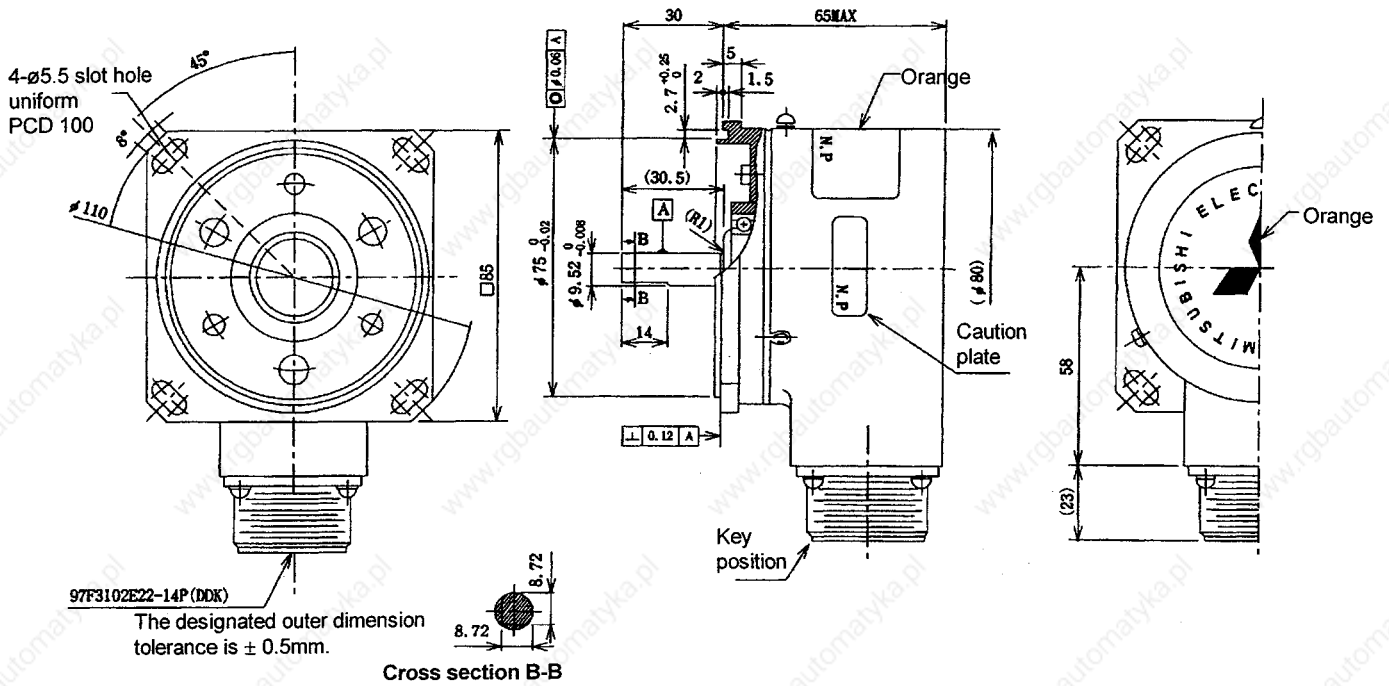

Connector: 97F3102E22-14P (DDK)

| | |
|--------------------------|--|
| Weight | 1.0kg or less |
| Moment of inertia | 0.2×10^{-4} kg·m ² or less |
| Friction torque | 0.0196N·m or less |
| Thermal relay | Functions at $85 \pm 5^\circ\text{C}$ |

| Pin No. | Function | Pin No. | Function |
|---------|--|---------|---|
| A | A-phase signal | K | RQ (Request signal) |
| B | \bar{A} -phase signal | L | \overline{RQ} ($\overline{\text{Request}}$ signal) |
| C | B-phase signal | M | NC |
| D | \bar{B} -phase signal | N | Case grounding |
| E | VB (Battery) | P | NC |
| F | Z-phase signal | R | GND |
| G | \bar{Z} -phase signal | S | +5VDC |
| H | RX signal (Serial absolute signal) | U | Thermal relay |
| | | T | NC |
| J | \overline{RX} signal (Serial absolute signal) | V | Thermal relay |

Cautions

- * This is an incremental encoder for the ball screw end.
- * The outline dimensions are the same as for the absolute value encoder, and only the nameplate color differs.

3.4 Serial pulse encoder

3.4.1 Features

- (1) With the serial pulse encoder, high resolution and high speed can be handled, allowing high resolution position detection to be selected.
- (2) The detector resolutions include the following two types.
 - ① 1,000,000p/rev (ABS/INC)
 - ② 100,000p/rev (ABS/INC)

Various detection units can now be handled according to the machine specifications.
- (3) The signal wiring can be decreased compared to the conventional A, B, Z signals.
- (4) The serial pulse encoder series is available for the standalone type encoder (ET Series). However, there are restrictions to the combination with conventional parts.
- (5) The L dimensions are approx. 25mm shorter than the conventional part for the small capacity servomotor (200/300W).
- (6) By achieving a smooth speed waveform, an improved effect of the new robust control (disturbance observer, etc.) function that carries out estimation from the speed can be anticipated.

3.4.2 Types

(1) Motor end encoder

| | Type | Resolution |
|-------------------------|--------|----------------|
| Absolute value detector | OSA105 | 1,000,000p/rev |
| | OSA104 | 100,000p/rev |
| Incremental detector | OSE105 | 1,000,000p/rev |
| | OSE104 | 100,000p/rev |

(2) Standalone encoder (machine end detection)

| | Type | Resolution |
|-------------------------|-----------|----------------|
| Absolute value detector | OSA105ET | 1,000,000p/rev |
| | OSA105ET1 | |
| | OSA104ET | 100,000p/rev |
| | OSA104ET1 | |
| Incremental detector | OSE105ET | 1,000,000p/rev |
| | OSE105ET1 | |
| | OSE104ET | 100,000p/rev |
| | OSE104ET1 | |

The ET1 has notches. (Refer to the outline drawing in section 3.4.3.)

3. Detectors

3.4.3 Outline drawing

- (1) The outline dimensions of the medium capacity series (HA40N and higher) motor and detector are the same as the M500 Series.
- (2) For the small capacity series (HA23N/33N), the motor L dimension (detector) is shorter than the current dimensions of the M500 Series.

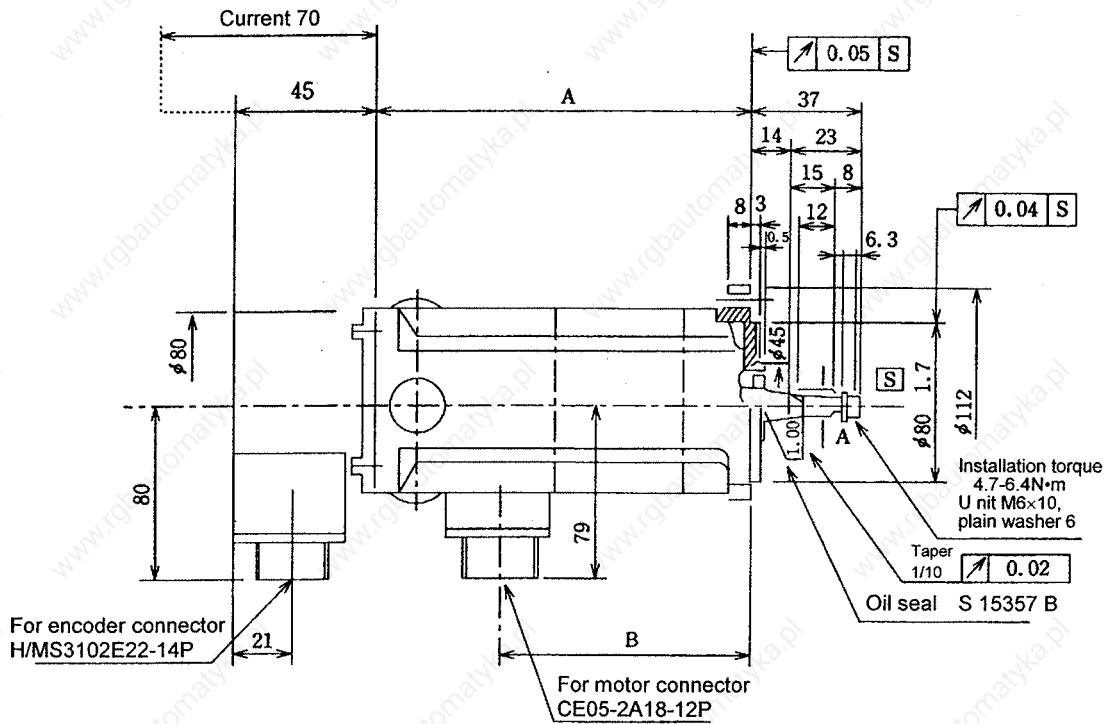

| Motor type | Changed dimensions | | Weight (kg) |
|------------|--------------------|-----|-------------|
| | A | B | |
| HA23NC-TS | 125 | 81 | 3.5 |
| HA33NC-TS | 155 | 111 | 4.5 |

The changed dimensions are equivalent to the current dimensions.

3. Detectors

(3) Standalone encoder (ET Series) outline drawings

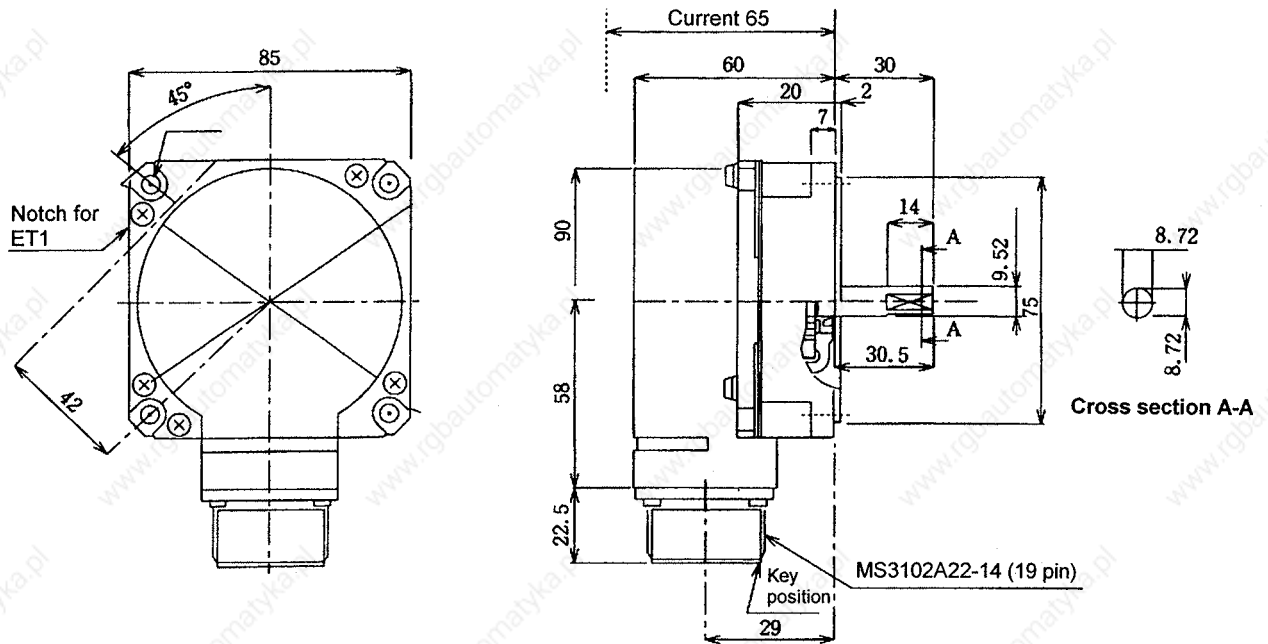

3.4.4 Cable connection diagram

CAUTION

Do not mistake the connection when manufacturing the detector cable. Failure to observe this could lead to runaway.

The conventional CNV2 and 3 can be used for the cable.
To reduce the amount of wiring, the following serial encoder dedicated cable can be used.
In this case, the conventional detector cannot be used.

3. Detectors

(1) CNV12, CNV13 cable ($L \leq 20m$)

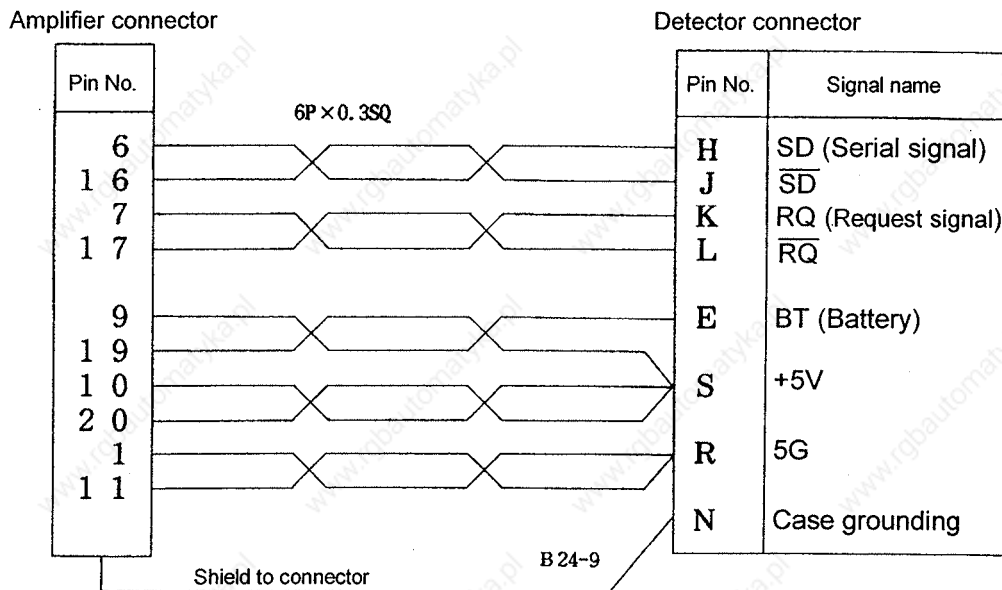

(2) CNV12, CNV13 cable ($20 \leq L \leq 30m$)

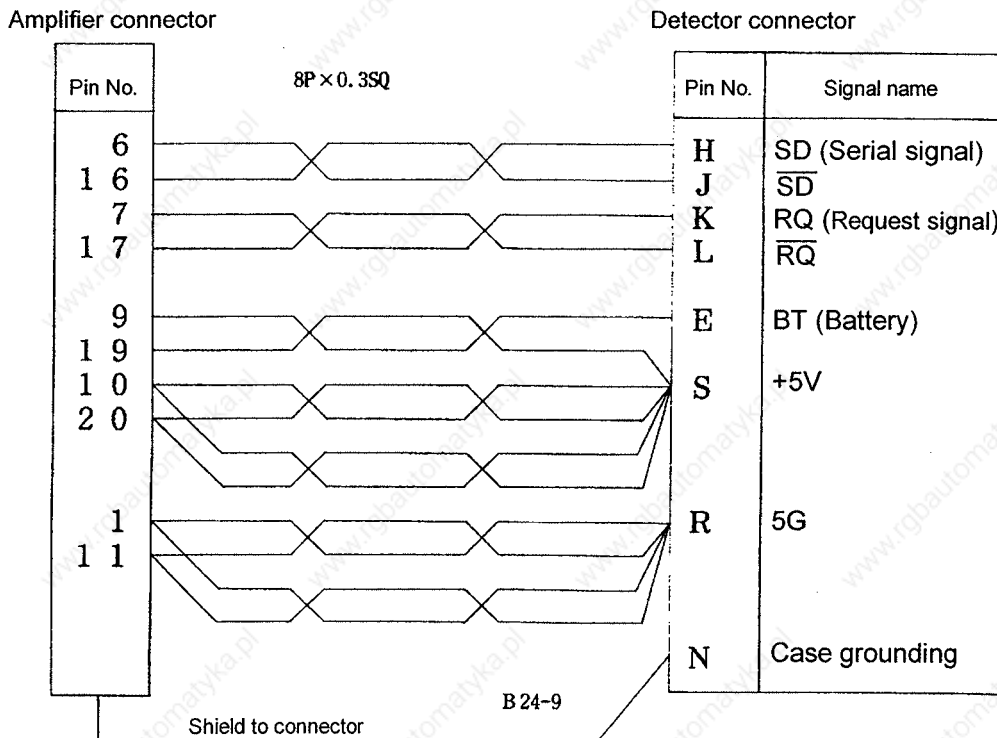

The same cables as the conventional CNV2 and 3 can be used for the amplifier side and detector side connectors.

3.4.5 Compatibility

(1) Servo amplifier

- The amplifier types that correspond to the serial pulse encoder for the MDS-A Series are the same. The indication has been change as shown below.
- The MDS-B Series has been compatible from the start.

Amplifier type indication label on upper left of front panel
 Type indicated with black characters on white base
 → Type indicated with black characters on yellow base

The servo amplifier itself can be driven by the current encoder.
 The cables used for the current encoder can be used for the detector cable.

(2) Servomotor

The servomotor type is the same as the current type.

(3) Software

- The servo software corresponding to the serial pulse encoder is as follows for the MDS-A Series.
BND-510W000-B0 and above
- Parameters requiring changes

① For 100,000 pulse encoder

The same parameter settings as the conventional detector can be used.

| No. | Name | Servo system | Current M500 compatible encoder | | Serial pulse encoder | |
|-------|------|--------------|---------------------------------|--------|----------------------|--------|
| | | | OHE25K | OHA25K | OSE104 | OSA104 |
| SV025 | MTYP | Semi-closed | 00** | 11** | 00** | 11** |
| | | Closed | 80** | 81** | 80** | 81** |

② For 1,000,000 pulse encoder

| No. | Name | Servo system | Current M500 compatible encoder | | Serial pulse encoder |
|-------|------|--------------|---------------------------------|--------|----------------------|
| | | | OHE25K | OHA25K | OSE105/OSA105 |
| SV025 | MTYP | Semi-closed | 00** | 11** | 22** |
| | | Closed | 80** | 81** | 82** |
| SV019 | RNG1 | Semi-closed | 100 | 100 | 1000 |
| | | Closed | # | # | # |
| SV020 | RNG2 | Common | 100 | 100 | 1000 |

- Set the motor type for *.
- Set the machine end detector resolution for #.
 (Resolution per ball screw pitch: k pulse)

3. Detectors

(4) Restrictions

- When using ball screw end detection, the correct combination of the motor end and ball screw end detector is limited to those shown with "⊙" in the following table.
- When using the OHA25K-ET ball screw end detector and configuring an absolute position system, alarm 18 (initial communication error) will occur, and operation will not be possible.
- Table of detector combinations for ball screw end detection
(All combinations are possible when using as an incremental system.)

| Motor end detector | Ball screw end (machine end) detector | | | |
|--------------------|---------------------------------------|-----------|----------------|----------------|
| | OHE25K-ET | OHA25K-ET | OSE104ET/105ET | OSA104ET/105ET |
| OHE25K | ⊙ | ⊙ | ○ | ○ |
| OHA25K | ⊙ | ⊙ | ○ | ○ |
| OSE104/105 | ○ | × | ⊙ | ⊙ |
| OSA104/105 | ○ | × | ⊙ | ⊙ |

⊙ : Correct combination, ○ : Not correct, but usable connection, × : Use not possible

3. Detectors

3.4.6 Maintenance



WARNING

1. Wait at least 10 minutes after turning the power OFF before starting maintenance or inspections. Failure to observe this could lead to electric shocks.
2. Only qualified persons must carry out the maintenance or inspections. Failure to observe this could lead to electric shocks. Contact your dealer for repairs or part replacements.

If any fault occurs in the configuration components, carry out service with the following procedures. Always follow the compatibility described in section 3.4.5 when servicing.

(1) Encoder

Always prepare the service parts for the conventional type and the serial encoder. As a rule, replace the detector with the same type as the original detector.

If changes are to be made, always confirm the compatibility and usable combination.

- Confirmation of encoder type
Confirm the encoder type on the nameplate attached to the motor cover, or displayed on the servo monitor screen.

Servo Monitor (SERVO DIAGNOSIS) Screen

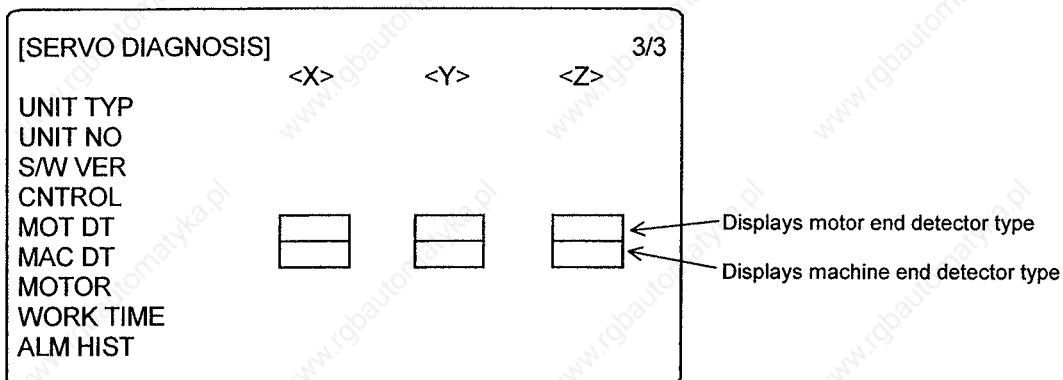

(2) Motor

If a fault occurs in the motor unit, replace the motor and encoder as a set.

- If the prepared encoder is the conventional OHE25K/OHA25K, it can be used in that state. Note that if the cable is dedicated for the serial encoder (refer to section 3.4.4 Cable connection diagram), the OHE25K/OHA25K cannot be used.
- If the prepared encoder is the serial encoder OSE/OSA, confirm that the servo drive type seal is the new yellow type, and that the servo software version is "B0" and above.

(3) Servo drive/servo software version

- The units have been changed to the new type from production starting in October 1995. Thus, all servicing of this type of servo drive is covered. Carry out servicing with this new type of servo drive.
- If the conventional encoder is installed, servicing is possible with the conventional type of servo drive. For the compatible servo software version use "B0" and above.

(4) Encoder cable

- The cable can be used commonly if it is the conventional type.
- When using the serial encoder dedicated cable, OHE25K/OHA25K cannot be used.

(5) Servo parameters.

- Changes are not required.

4. Servomotor and Detector Installation

4.1 Installation

CAUTION

1. Do not hold the cable, shaft and detector when transporting the servomotor. Failure to observe this could lead to damage or injuries.
2. Use the suspension bolts on the servomotor only to transport the servomotor. Do not transport the servomotor when it is installed on the machine.
3. Always install the servomotor with reduction gears in the designated direction. Failure to observe this could lead to oil leaks, fires and damage.
4. Securely fix the servomotor onto the machine. If fixed insufficiently, the unit could come off during operation and lead to injuries.
5. When connecting a coupling to the servomotor shaft end, do not apply an impact by using a hammer, etc. Failure to observe this could lead to detector damage.
6. Install a cover, etc., on the shaft so that the rotating sections of the servomotor are not contacted during operation.
7. Do not apply a load exceeding the tolerable load on the servomotor shaft. Failure to observe this could cause the shaft to break and to injuries.

(1) Precautions for oil and water

- a. Since the servomotor is not water/oil resistant do not splash cutting fluid or lubrication oil on the servomotor. If cutting fluid, etc., enters the servomotor or the detector, the insulation of the motor coil may be damaged or the detector failure may occur.
- b. If cutting fluid, etc., splashes on the motor, put a protection cover on the motor. Check the joints, bends, shape, and dimensions of the protection cover.
- c. Use the oil-proof specifications wiring tube and oil-proof connector when using the servomotor in an environment where it will be exposed to large amounts of cutting fluid or the protection cover is not adequate.
- d. Do not use the servomotor if part of the servomotor is submerged in oil or water. When the servomotor is located near the floor, install a water drain path on the floor to direct the flow. Do not clog the water drain path with cutting chips.
- e. Check the drain path of oil and water on the moving table and the slide cover.
Be aware of the following conditions.
 - 1) When the table arrives at a specific position, the drain hole comes to the upper section of the motor. Thus, oil or water splashes the motor.
 - 2) Depending on the movement of the slide cover and table, oil or water which stays on the slide cover or table splashes the motor.
 - 3) Depending on the shrinkage or expansion of the cover, oil or water which stays on the slide cover leaks from the wiper section and drops on the motor.
- f. The servomotor should be installed in a well ventilated place where oil and water will not splash it, and where it can be easily installed or removed.

(2) Precautions against gear oil

- a. Although the servomotor can be installed horizontally or at the upper or lower end of the axis, when the servomotor is installed at the upper end, take extra measures on the machine side to avoid oil from the gear box, etc., from entering the motor. In this situation, the oil seal of the motor is not sufficient protection.
- b. Oil level and pressure in the gear box
The oil level in the the gear box where the servomotor is horizontally mounted should be always lower than the oil seal lip of the servomotor shaft (both in the stop and rotation states). If the oil level is higher than the oil lip, oil may enter the motor. Some servomotors are not provided with shaft end oil seals. To prevent the inner pressure of the gear box from increasing, provide an intake-hole on the gear box.

4. Servomotor and Detector Installation

[Machine side]

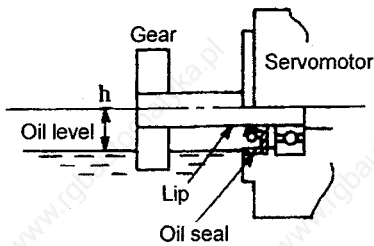

| Model | Height from center of motor shaft h (mm) |
|---|--|
| HA053 HA13 | 8 |
| HA23N HA33N | 10 |
| HA40N HA43N HA80N HA83N HA50L HA100NL HA150NL HA53NL HA103NL HA153NL | 20 |
| HA100N, HA103N, HA200N, HA203N, HA300N, HA303N, HA700N, HA703N HA200NL, HA300NL, HA203NL, HA303NL | 25 |
| HA900N HA500NL HA503NL HA-LH11K2 | 30 |
| HA-LH15K2 | 40 |

(3) Detector

- When transporting and installing the servomotor, avoid shocks to the detector on the servomotor. To prevent items from hitting the detector workers from getting on the detector and tools or workpieces from dropping on the detector, install a protection cover around the detector. Any design where a coupling should be struck to the motor shaft should be avoided to prevent damage to the detector.
- The detector cover for motors other than HA053, HA13, HA23N and 33N can be turned 90°, but design the machine so that it faces the "A" direction as a standard. The direction of the detector connector for HA053 and HA13 cannot be changed. The parameter settings must be changed when the connector is faced in the B, C or D directions for the HA23N and 33N motors. (The setting changes are complicated and the combinations may be mistaken, so the connector direction should not be changed if possible.)

Symbol of direction of detector connector
(The "A" direction is standard.)

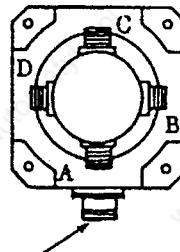

Terminal box or motor connector

- The detectors for motors other than HA23N and 33N are fixed to the motor with pins. The HA23N and 33N motor detectors are fixed to the motor with screws, but the polarity must be matched correctly when installing. If this is ignored and the detector is replaced or the detector connector direction is changed, the control will not be possible, and the motor may run out of control. The relation of the detector and motor position should not be changed after delivery from Mitsubishi.

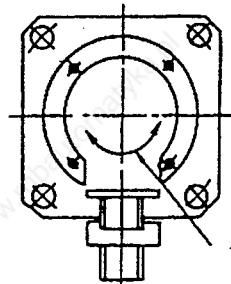

The direction of the connector cannot be changed.

- When using the low inertia motor and IP67 compatible motor, do not remove the encoder and encoder cover. The magnetic pole position of the low inertia motor has been adjusted when the encoder was installed. The IP67 compatible motor has been tested in water with the encoder and cover installed.

4. Servomotor and Detector Installation

(4) Connector and cable

- a. The connector should be located so that it faces downward.
When the motor is installed vertically or on an incline, provide a cable trap.

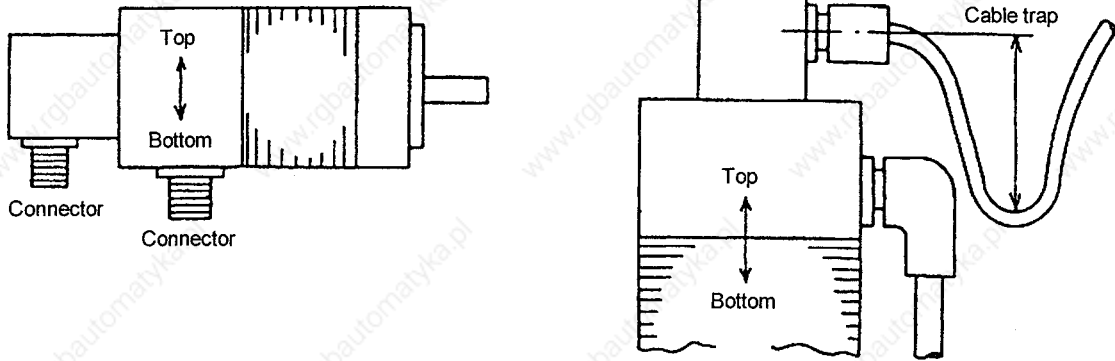

- b. The standard cannon plugs are not waterproof.
c. The cables may lead oil and water to the motor and the detector, causing negative effects. Avoid allowing the cables to lead oil and water to the motor and the detector, and do not allow the cables to dip in oil and water (see the following figure).

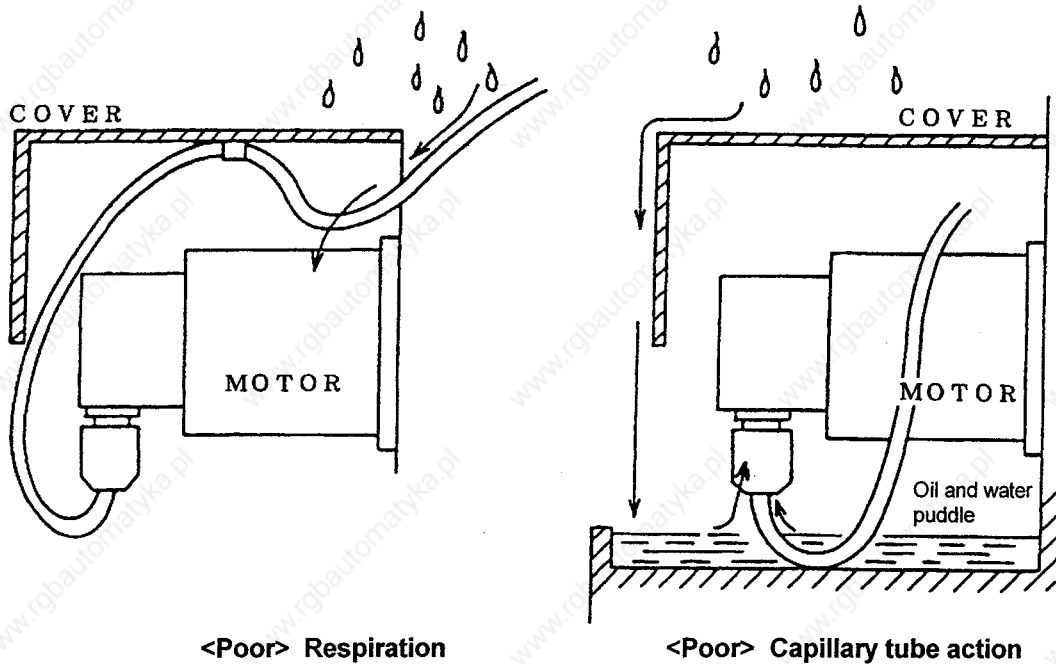

- d. Adhere to the cable clamping method and avoid bending or stressing the cable connections under the dead weight of the cable.
If the motor shifts, the cable bending radius should be determined according to the required bending life and the cable type.
e. Prevent sharp chips from cutting the cable's outer sheath and from being abraded by contact with any edge of the machine. In addition, prevent the cable from being trampled by people and automobiles.

4. Servomotor and Detector Installation

(5) Attaching/detaching connectors

- a. While the machine is turned on, do not connect or disconnect any connector to or from the machine, otherwise, the motor may be damaged. Also, avoid dropping the machine and abrupt motor start, or generation large arcs may occur.
It is recommended to tie each cannon plug with a wire.
- b. Even when the power is turned off, the absolute value detector is backed up by a battery. Thus, when the detector cable is disconnected, the absolute position is lost. It is recommended to tie this plug with a wire and indicate a warning sign "do not disconnect this plug even while power is turned off."
- c. The cannon plugs are tightened manually. Provide enough space to correctly tighten each cannon plug.

(6) Applications involving vibration

Tie the cannon plugs and cable clamps of the motor and detector with wires. Clamp carefully to avoid vibration stress and the stress of the cable dead weight on the cable connections, both of which may affect the relationship between the cable finish diameter and the clamp size. In addition, check that the clamps are not loose.

Include the retightening of the cannon plugs and the clamps in the machine manual as a periodical inspection item.

● Safety holes for protection against connector separation

If the coupling nut has safety holes, when the connector is exposed to strong shock and vibration, pass a wire through the holes and fix the connector to protect the connector from being disconnected. Under normal conditions, this treatment is not required (extracted from a catalog).

- Since the cable clamp has two safety holes which are similar to the connector, it can also be fixed.
- The safety holes differ slightly in structure depending on the manufacturer.

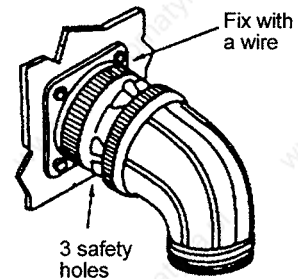

● Fixing wire (0.813ø annealed stainless steel wire)

QQ-W-423 FORM-1 FS304 CD-A 0.032 (inches) is recommended because of its mechanical strength and easy machining.

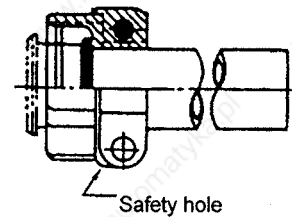

● Optimum tightening torque for coupling nuts

The connector is designed so that it can be easily tightened by turning the coupling nut manually without using a special tool. When the connector is exposed to vibration, it should be fixed with a wire. There is no regulation for the tightening torque in the MIL Standards.

When this connector is used for an airplane, the connector should be fixed with a wire by the user.

- (7) Any design which requires modification, disassembling, or additional machining of the motor should be avoided.

4. Servomotor and Detector Installation

4.2 Coupling with the load

The motor shaft is coupled to the machine by one of the following methods:

The direct coupling method, in which the motor shaft is coupled directly to the machine by a flexible joint.

The gear method, in which the motor speed is reduced when using a gear.

The timing belt method, in which the motor shaft is coupled to the machine using a timing belt.

This method is an important factor that affects the machine performance.

The following table outlines comparisons among the three methods.

| | Noise | No lubrication | Backlash | Rigidity | Reliability of coupling | Life | Torque up by speed reduction | Degree of freedom of installing motor | Cause of motor shaft breakage |
|-----------------|-------|----------------|----------|----------|-------------------------|------|------------------------------|---------------------------------------|--|
| Direct coupling | ○ | ○ | ○ | ○ | ○ Looseness of bolt | ○ | × | × | Misalignment of shaft center |
| Gear | × | × | △ | △ | △ Breakage of teeth | △ | ○ | ○ | Too small backlash, undersized pitch diameter |
| Timing belt | △ | ○ | ○ | × | × | × | ○ | ○ | Excess belt tension, undersized pitch diameter |

(1) Direct coupling

When a load is directly coupled to the motor shaft, use a flexible joint. Although the flexible joint can absorb misalignment, to maximize the durability of the machine, it is necessary to completely match the load with the shaft center during the initial installation. In addition, it is necessary to periodically adjust the misalignment. When the flexible joint is used, carefully select a joint according to the environmental conditions and operate it according to the specification manual issued by the manufacturer.

Although a coupling whose rigidity is low decreases the alignment accuracy, it is not preferable for the servomotor. To use the submicron specification, skillfully align it, and use a high rigidity coupling. When such conditions are not satisfied, the servo performance cannot be maximized, (the gain cannot be increased) and the motor shaft may break.

Example of direct coupling with load

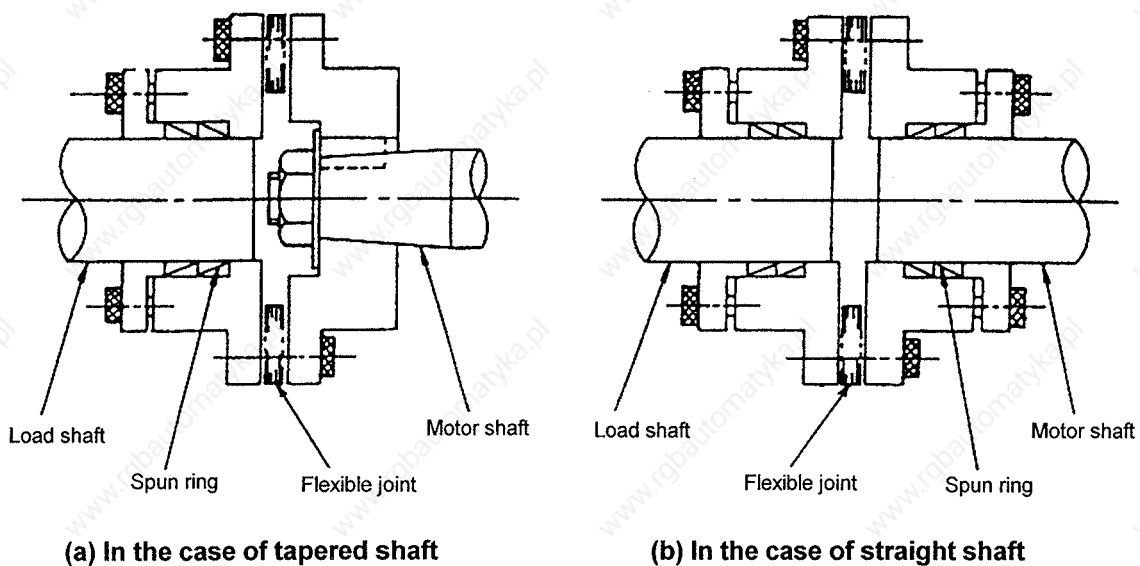

4. Servomotor and Detector Installation

(2) Gear coupling

To obtain a large torque by reducing speed, a gear is used between the motor shaft and the load.

The accuracy of the gear and the amount of backlash depend largely on the accuracy of the machine positioning and the noise of the machine operation.

In the gear coupling method, it is necessary to properly select the accuracy and the amount of the backlash.

In the gear coupling method, take measures to prevent oil from entering the motor. For details, see section 4.1(2).

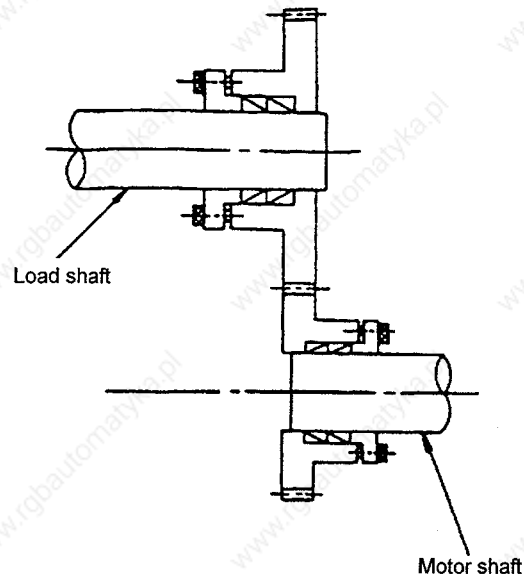

Example of coupling with load using gear

(3) Spun ring

Since the output shaft of a servomotor of 2 kW or greater does not have a key groove, it is necessary to use a frictional joint such as a spun ring for coupling with the load shaft.

For details of the usage of the spun ring, contact the manufacturer or dealer.

● Table of characteristics and dimensions RfN8006

| d × D mm | L mm | ℓ mm | Effective contact area Ft mm ² | Note 1 P _O N | Note 2 P _A N | Transmission torque Mt N·m | Tangent transmission force Pax N | Gap xmm | | | | Weight G kg |
|-------------|---------|---------|--|-------------------------------|-------------------------------|-------------------------------------|---|---------------|---|---|---|-------------------|
| | | | | | | | | Number of set | | | | |
| | | | | | | | | 1 | 2 | 3 | 4 | |
| 11×14 | 4.5 | 3.7 | 128 | 7502 | 6933 | 8.43 | 1540 | 2 | 2 | 3 | 3 | 0.00198 |
| 24×28 | 6.3 | 5.3 | 400 | 8189 | 21182 | 56.88 | 4707 | 3 | 3 | 4 | 5 | 0.0068 |
| 35×40 | 7 | 6 | 659 | 9905 | 34912 | 135.33 | 7747 | 3 | 3 | 4 | 5 | 0.014 |

- Notes**
1. Axial pressure necessary for allowing the engagement clearance to be 0.
 2. Net pressure force necessary for producing transmission force

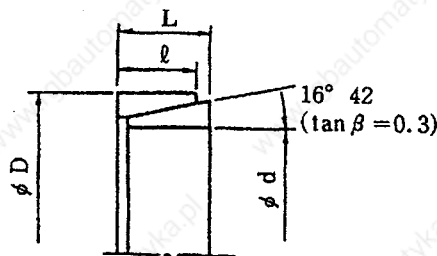

Outline dimension drawing of RfN8006

Various manufacturers produce frictional joints as substitutes of spun ring.

The specifications, dimensions, etc., of the products may differ depending on the manufacturers.

When using them, carefully check the specifications.

4. Servomotor and Detector Installation

(4) Taper gauge

The standard shaft end of a servomotor of 1 kW or less is a tapered shaft. When the taper should be matched on the machine side, a copy gauge should be made in accordance with the master gauge of Mitsubishi Electric.

The copy gauge should be directly ordered through the following manufacturer. Note the following items.

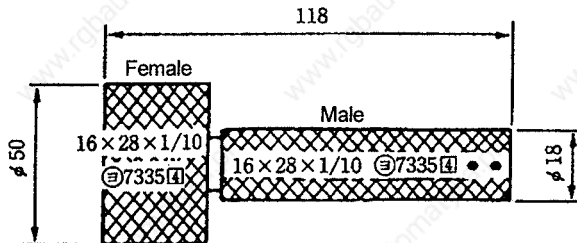

- 1) Place order with:
Chubu Seiki Seisakusho
- 2) Requirement:
Taper gauge (copy): 16 × 28 × 1/10
Mitsubishi Nagoya Works should have the master of the copy gauge.
(Ⓜ 7335)

(5) Other reference items

The shapes and dimensions of the servomotor mounting flange section and the shaft end conform to the standards of Japan Machine Tool Industry Association MAS402.

The only available coupling methods for the servomotor for the MCI machine tool are the method using the straight shaft without the key (spun ring) and the method using the taper shaft end.

The method of the straight shaft with the key cannot be practically used because of the wear caused by the backlash of the key.

The method by which the motor shaft and the boss are simultaneously machined, and a taper pin is used to couple them, should be avoided because a service motor is not provided. A motor modified in such a manner cannot be repaired and the spare parts may not be supplied.

For the strength of the motor shaft, see section 2.11.

For the operation of the electromagnetic brake when a timing belt is coupled in the vertical axis, see section 2.9 (3). Assuming that the diameter of ball screw is D_m (mm) and the speed is N (rpm), the following relation is satisfied.

$$D_m N < 70000.$$

This performance can be enhanced by controlling the lubrication and cooling methods.

As the standard for precision ball screws, JIS-B-1192 has been issued.

Tightening torque for tapered shaft end screw.

The screw shaft will be damaged if the tightening torque of the tapered shaft end screw is too tight. Follow the values given below when tightening.

| Model | Tapered shaft end screw tightening torque | Reference | |
|----------------------------|---|------------|-------------------|
| | | Screw size | Tightening torque |
| HA23N HA33N | 4.71 to 6.37N·m | M6 × 1.0 | Approx. 300kg |
| HA40N HA43N HA80N HA83N | 22.56 to 30.40N·m | M10 × 1.25 | Approx. 900kg |

5. MDS-A/B-V1 Servo Drive

5.1 Model configuration

MDS - A - V1 -

MDS - B - V1 -

Servo drive capacity class symbol

| Symbol | Capacity kW | Applicable motor | | | |
|--------|-------------|--------------------|--------------------|-----------------------|-----------------------|
| | | Standard 2000r/min | Standard 3000r/min | Low inertia 2000r/min | Low inertia 3000r/min |
| 01 | 0.1 | | HA053 HA13 | | |
| 03 | 0.3 | | HA23N HA33N | | |
| 05 | 0.5 | HA40N | HA43N | HA50NL | |
| 10 | 1.0 | HA80N | HA83N | HA100NL | HA53NL |
| 20 | 2.0 | HA100N | | HA150NL HA200NL | HA103NL HA153NL |
| 35 | 3.5 | HA200N | HA103N | HA300NL | HA203NL |
| 45 | 4.5 | HA300N | HA203N | HA500NL | HA303NL |
| 70 | 7.0 | HA700N | HA303N | | HA503NL |
| 90 | 9.0 | HA900N | HA703N | | |
| 110 | 11.0 | | | HA-LH11K2 | |
| 150 | 15.0 | | | HA-LH15K2 | |

- * The V1-110/150 has been added from the MDS-B Series.
The V1-110/150 servo drive unit does not have built-in dynamic brakes, so always install an external dynamic brake unit.

5. MDS-A/B-V1 Servo Drive

5.2 Servo drive specifications

| | | Servo drive model name | | | | | | | | | | |
|--|-------------------------|--|----------------|--------------------------|-------------------------------------|--|----------------------------|--|-----------------------------|------------------|---------------|---------------|
| | Unit | MDS-A/B- | | | | | | | | | MDS-B- | |
| | | V1-01 | VI-03 | VI-05 | VI-10 | VI-20 | VI-35 | VI-45 | VI-70 | VI-90 | VI-110 | VI-150 |
| Applicable motor | | HA053 HA13 | HA23N HA33N | HA40N HA43N HA50NL | HA80N HA83N HA100NL HA53NL | HA100N HA150NL HA200NL HA103NL HA153NL | HA200N HA103N HA203N | HA300N HA203N HA500NL HA303NL | HA700N HA303N HA503NL | HA900N HA703N | HA-LH11K2 | HA-LH15K2 |
| Output voltage | Vrms | 155 | | | | | | | | | | |
| Rated output current | Ams | 0.95 | 2.9 | 3.4 | 6.8 | 13 | 16 | 28 | 33.5 | 42 | 68 | 87 |
| Stall current | Arms | 1.4 | 3.0 | 5.0 | 8.8 | 18.2 | 25 | 44 | 55 | 68 | 84 | 100 |
| Maximum output current | Arms | 3.9 | 8.1 | 17 | 28 | 42 | 57 | 85 | 113 | 141 | 204 | 260 |
| Maximum output torque (During combination with motor) Same order as applicable motor | N·m (kg·cm) | 0.69 (7) | 2.75 (28) | 14.2 (145) | 25.5 (260) | 42 (428) | 60 (610) | 87 (893) | 120 (1220) | 153 (1565) | 158 (1610) | 215 (2190) |
| | | 1.37 (14) | 5.6 (57) | 10.2 (104) | 19.2 (196) | 31 (320) | 40 (410) | 56 (570) | 80 (814) | 105 (1072) | | |
| | | | | 13.0 (133) | 20.7 (213) | 32 (323) | 52 (530) | 72 (740) | | | | |
| | | | | | 14.1 (144) | 22.5 (229) | 37 (380) | 60 (610) | 78 (795) | | | |
| Control system | | Sine wave PWM system | | | | | | | | | | |
| Main circuit system | | Transistor inverter (Intelligent power module using IGBT) | | | | | | | | | | |
| Braking | | Regeneration brake and dynamic brake | | | | | | | | | | |
| Dynamic brakes | | Built-in | | | | | | | | | External | |
| Tolerable load inertia | | As a guideline, less than 2.5 times the motor inertia | | | | | | | | | | |
| Tolerable environmental temperature | °C | 0° to 55°C | | | | | | | | | | |
| Tolerable environmental relative humidity | % | 90% or less (with no dew condensation) | | | | | | | | | | |
| Storage temperature | °C | -15° to 70°C | | | | | | | | | | |
| Storage relative humidity | % | 90% or less (with no dew condensation) | | | | | | | | | | |
| Atmosphere | | No harmful gas and dust | | | | | | | | | | |
| Tolerable vibration | m/s ² (G) | 4.90m/s ² (0.5G) | | | | | | | | | | |
| Tolerable shock | m/s ² (G) | Acceleration: 49.03m/s ² (5G) | | | | | | | | | | |
| Maximum heat dissipation | W | Refer to the Chapter I Servo/Spindle System Configuration. | | | | | | | | | | |
| Weight | kg | 3.5 | 3.5 | 3.5 | 4.5 | 4.5 | 4.5 | 6.0 | 7.0 | 7.0 | 10.0 | 10.0 |
| Capacity | kW | 0.1 | 0.3 | 0.5 | 1.0 | 2.0 | 3.5 | 4.5 | 7.0 | 9.0 | 11.0 | 15.0 |
| Torque limit range | % | 0 ~ 100% | | | | | | | | | | |
| Noise | dB (A) | Less than 55dB | | | | | | | | | | |

5.3 Connection of dynamic brake unit

The V1-110/150 servo drive unit does not have built-in dynamic brakes, so always install an external dynamic brake unit.

| Model name | Coil specification | Compatible amplifier |
|---------------|--------------------|----------------------|
| MDS-B-DBU-150 | 24VDC 160mA | V1-110/150 |

5. MDS-A/B-V1 Servo Drive

(1) When using only dynamic brake unit

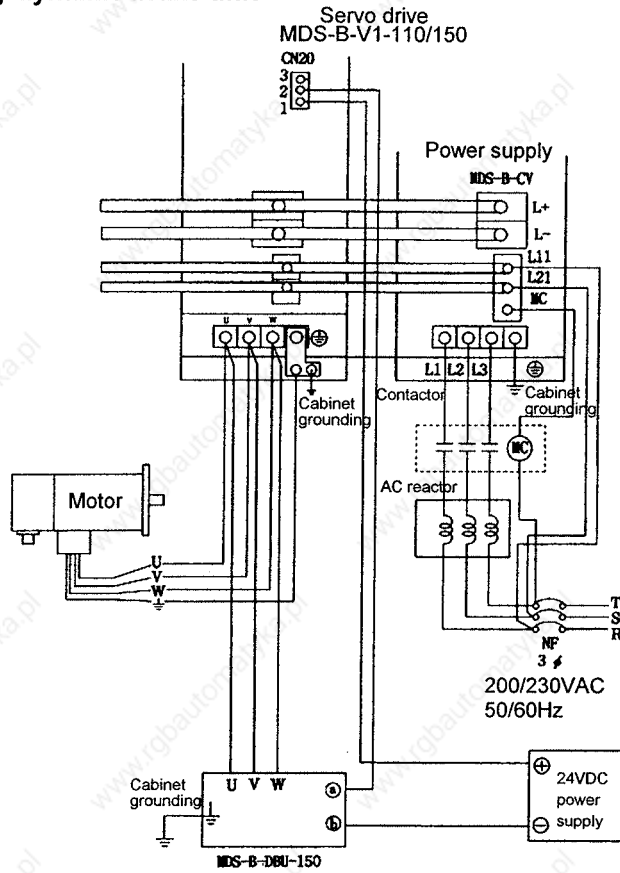

(2) When using dynamic brake unit + magnetic brakes (combination use)

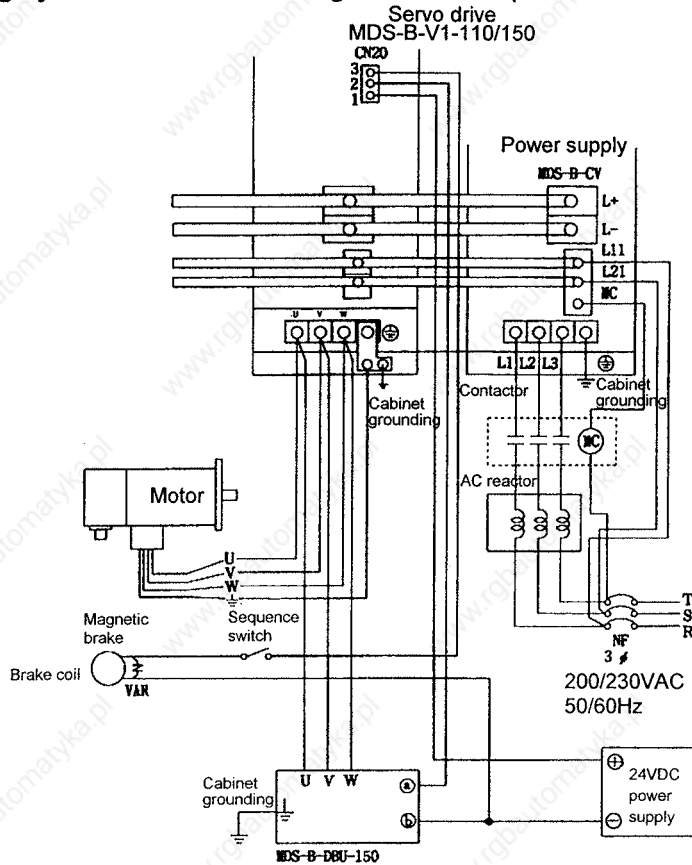

5.4 Hardware setting

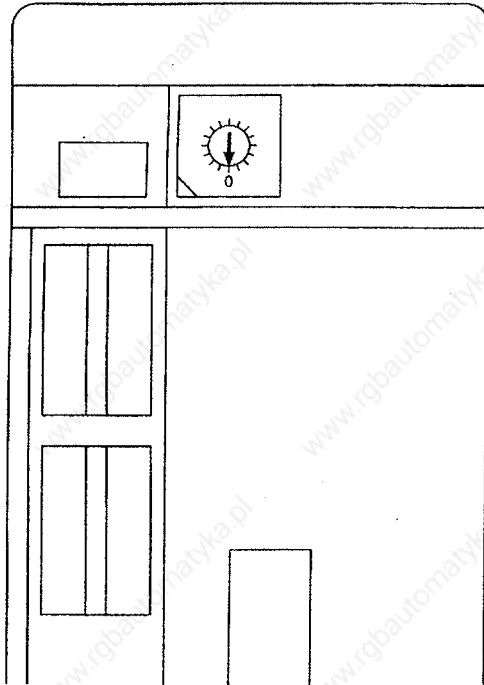

| Function | Setting | Meaning |
|------------------------|---------|-------------------------|
| Axis No. setting CS | 0 | 1st axis |
| | 1 | 2nd axis |
| | 2 | 3rd axis |
| | 3 | 4th axis |
| | 4 | 5th axis |
| | 5 | 6th axis |
| | 6 | 7th axis |
| | 7 ~ E | Not usable |
| | F | Not used axis selection |

The servo amplifier axis No. can be set by opening the upper lid (next to LED status display window) on the top of the MDS-A/B-V1 servo amplifier, and turning the rotary switch. When the rotary switch is set to "F" and the servo amplifier power is turned on, that axis will not be controlled. Thus, set axes that are not being used to "F". (The communication with the NC will not take place during initialization, and an alarm will not occur.)

In the above example, the 1st axis is set.

5.5 Parameter settings

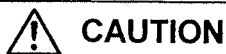

Do not make remarkable adjustments or changes of the parameters as the operation may become unstable.

(1) Parameter screens

The servo parameters are set on the NC [M_PARAM] screens.

Examples of the screen displays are shown for the 14" CRT screen.

There are a total of 64 servo parameters. Screen page 1 shows the parameters regarding the specifications, and page 2 an excerpt of the parameters used for adjustment. Pages 3 and following are all parameters for SV001 to SV064.

The parameters can be changed from any screen.

| [SERVO PARAM] | | M_PARAM 5. 1/6 | | | | | |
|---------------|------------|----------------|------|------|------|------|------|
| # | (X) | (Y) | (Z) | (W) | (A) | (C) | |
| 1 | SPEC (HEX) | 0000 | 0000 | 0000 | 0000 | 0000 | 0000 |
| 2 | MTYP (HEX) | 0002 | 0002 | 0002 | 0002 | 0002 | 0002 |
| 3 | PTYP (HEX) | 0000 | 0000 | 0000 | 0000 | 0000 | 0000 |
| 4 | SSF1 (HEX) | 0000 | 0000 | 0000 | 0000 | 0000 | 0000 |
| 5 | SSF2 (HEX) | 0000 | 0000 | 0000 | 0000 | 0000 | 0000 |
| 6 | PC1 | 1 | 1 | 1 | 1 | 1 | 1 |
| 7 | PC2 | 1 | 1 | 1 | 1 | 1 | 1 |
| 8 | PFT | 10 | 10 | 10 | 10 | 10 | 10 |
| 9 | RNG1 | 100 | 100 | 100 | 100 | 100 | 100 |
| 10 | RNG2 | 100 | 100 | 100 | 100 | 100 | 100 |
| 11 | PGN | 33 | 33 | 33 | 33 | 33 | 33 |

#(11)AXIS<X>DATA(33)

BASE1 | BASE2 | AXIS | ZP-RTN | SERVO | MC-ERR | MACRO | \$-SELECT | MENU

| [SERVO PARAM] | | M_PARAM 5. 2/6 | | | | | |
|---------------|----------|----------------|-----|-----|-----|-----|-----|
| # | (X) | (Y) | (Z) | (W) | (A) | (C) | |
| 1 | PGN2 | 99 | 99 | 99 | 99 | 99 | 99 |
| 2 | YGN | 150 | 150 | 150 | 150 | 150 | 150 |
| 3 | VIA | 682 | 682 | 682 | 682 | 682 | 682 |
| 4 | VIL | 0 | 0 | 0 | 0 | 0 | 0 |
| 5 | FFC (%) | 0 | 0 | 0 | 0 | 0 | 0 |
| 6 | JL (%) | 150 | 150 | 150 | 150 | 150 | 150 |
| 7 | FHz (Hz) | 350 | 350 | 350 | 350 | 350 | 350 |
| 8 | TOF (%) | -20 | -20 | -20 | -20 | -20 | -20 |
| 9 | LMC1 | 30 | 30 | 30 | 30 | 30 | 30 |
| 10 | LMC2 | 40 | 40 | 40 | 40 | 40 | 40 |
| 11 | OVS1 | 25 | 25 | 25 | 25 | 25 | 25 |
| 12 | OVS2 | 35 | 35 | 35 | 35 | 35 | 35 |

#(11)AXIS<X>DATA(25)

BASE1 | BASE2 | AXIS | ZP-RTN | SERVO | MC-ERR | MACRO | \$-SELECT | MENU

| [SERVO PARAM] | | M_PARAM 5. 3/6 | | | | | |
|---------------|-------|----------------|------|------|------|------|------|
| # | (X) | (Y) | (Z) | (W) | (A) | (C) | |
| 1 | SV001 | 1 | 1 | 1 | 1 | 1 | 1 |
| 2 | SV002 | 1 | 1 | 1 | 1 | 1 | 1 |
| 3 | SV003 | 33 | 33 | 33 | 33 | 33 | 33 |
| 4 | SV004 | 99 | 99 | 99 | 99 | 99 | 99 |
| 5 | SV005 | 150 | 150 | 150 | 150 | 150 | 150 |
| 6 | SV006 | 150 | 150 | 150 | 150 | 150 | 150 |
| 7 | SV007 | 0 | 0 | 0 | 0 | 0 | 0 |
| 8 | SV008 | 682 | 682 | 682 | 682 | 682 | 682 |
| 9 | SV009 | 1024 | 1024 | 1024 | 1024 | 1024 | 1024 |
| 10 | SV010 | 1024 | 1024 | 1024 | 1024 | 1024 | 1024 |
| 11 | SV011 | 256 | 256 | 256 | 256 | 256 | 256 |
| 12 | SV012 | 256 | 256 | 256 | 256 | 256 | 256 |
| 13 | SV013 | 500 | 500 | 500 | 500 | 500 | 500 |
| 14 | SV014 | 500 | 500 | 500 | 500 | 500 | 500 |
| 15 | SV015 | 0 | 0 | 0 | 0 | 0 | 0 |
| 16 | SV016 | 40 | 40 | 40 | 40 | 40 | 40 |

#(14)AXIS<X>DATA(500)

BASE1 | BASE2 | AXIS | ZP-RTN | SERVO | MC-ERR | MACRO | \$-SELECT | MENU

| [SERVO PARAM] | | M_PARAM 5. 4/6 | | | | | |
|---------------|-------|----------------|------|------|------|------|------|
| # | (X) | (Y) | (Z) | (W) | (A) | (C) | |
| 17 | SV017 | 0000 | 0000 | 0000 | 0000 | 0000 | 0000 |
| 18 | SV018 | 10 | 10 | 10 | 10 | 10 | 10 |
| 19 | SV019 | 100 | 100 | 100 | 100 | 100 | 100 |
| 20 | SV020 | 100 | 100 | 100 | 100 | 100 | 100 |
| 21 | SV021 | 150 | 150 | 150 | 150 | 150 | 150 |
| 22 | SV022 | 60 | 60 | 60 | 60 | 60 | 60 |
| 23 | SV023 | 2 | 2 | 2 | 2 | 2 | 2 |
| 24 | SV024 | 50 | 50 | 50 | 50 | 50 | 50 |
| 25 | SV025 | 0002 | 0002 | 0002 | 0002 | 0002 | 0000 |
| 26 | SV026 | 2 | 2 | 2 | 2 | 2 | 2 |
| 27 | SV027 | 0000 | 0000 | 0000 | 0000 | 0000 | 0000 |
| 28 | SV028 | 0 | 0 | 0 | 0 | 0 | 0 |
| 29 | SV029 | 400 | 400 | 400 | 400 | 400 | 400 |
| 30 | SV030 | 64 | 64 | 64 | 64 | 64 | 64 |
| 31 | SV031 | 25 | 25 | 25 | 25 | 25 | 25 |
| 32 | SV032 | -20 | -20 | -20 | -20 | -20 | -20 |

#(25)AXIS<X>DATA(0000)

BASE1 | BASE2 | AXIS | ZP-RTN | SERVO | MC-ERR | MACRO | \$-SELECT | MENU

| [SERVO PARAM] | | M_PARAM 5. 5/6 | | | | | |
|---------------|-------|----------------|------|------|------|------|------|
| # | (X) | (Y) | (Z) | (W) | (A) | (C) | |
| 33 | SV033 | 0000 | 0000 | 0000 | 0000 | 0000 | 0000 |
| 34 | SV034 | 0000 | 0000 | 0000 | 0000 | 0000 | 0000 |
| 35 | SV035 | 0000 | 0000 | 0000 | 0000 | 0000 | 0000 |
| 36 | SV036 | 0000 | 0000 | 0000 | 0000 | 0000 | 0000 |
| 37 | SV037 | 150 | 150 | 150 | 150 | 150 | 150 |
| 38 | SV038 | 350 | 350 | 350 | 350 | 350 | 350 |
| 39 | SV039 | 0 | 0 | 0 | 0 | 0 | 0 |
| 40 | SV040 | 0 | 0 | 0 | 0 | 0 | 0 |
| 41 | SV041 | 40 | 40 | 40 | 40 | 40 | 40 |
| 42 | SV042 | 35 | 35 | 35 | 35 | 35 | 35 |
| 43 | SV043 | 0 | 0 | 0 | 0 | 0 | 0 |
| 44 | SV044 | 0 | 0 | 0 | 0 | 0 | 0 |
| 45 | SV045 | 0 | 0 | 0 | 0 | 0 | 0 |
| 46 | SV046 | 0 | 0 | 0 | 0 | 0 | 0 |
| 47 | SV047 | 0 | 0 | 0 | 0 | 0 | 0 |
| 48 | SV048 | 0 | 0 | 0 | 0 | 0 | 0 |

#(48)AXIS<X>DATA(0)

BASE1 | BASE2 | AXIS | ZP-RTN | SERVO | MC-ERR | MACRO | \$-SELECT | MENU

| [SERVO PARAM] | | M_PARAM 5. 6/6 | | | | | |
|---------------|-------|----------------|-----|-----|-----|-----|-----|
| # | (X) | (Y) | (Z) | (W) | (A) | (C) | |
| 49 | SV049 | 15 | 15 | 15 | 15 | 15 | 15 |
| 50 | SV050 | 0 | 0 | 0 | 0 | 0 | 0 |
| 51 | SV051 | 100 | 100 | 100 | 100 | 100 | 100 |
| 52 | SV052 | 0 | 0 | 0 | 0 | 0 | 0 |
| 53 | SV053 | 2 | 2 | 2 | 2 | 2 | 2 |
| 54 | SV054 | 0 | 0 | 0 | 0 | 0 | 0 |
| 55 | SV055 | 0 | 0 | 0 | 0 | 0 | 0 |
| 56 | SV056 | 0 | 0 | 0 | 0 | 0 | 0 |
| 57 | SV057 | 0 | 0 | 0 | 0 | 0 | 0 |
| 58 | SV058 | 0 | 0 | 0 | 0 | 0 | 0 |
| 59 | SV059 | 20 | 20 | 20 | 20 | 20 | 20 |
| 60 | SV060 | 30 | 30 | 30 | 30 | 30 | 30 |
| 61 | SV061 | 0 | 0 | 0 | 0 | 0 | 0 |
| 62 | SV062 | 1 | 1 | 1 | 1 | 1 | 1 |
| 63 | SV063 | 1 | 1 | 1 | 1 | 1 | 1 |
| 64 | SV064 | -1 | -1 | -1 | -1 | -1 | -1 |

#(64)AXIS<X>DATA(-128)

BASE1 | BASE2 | AXIS | ZP-RTN | SERVO | MC-ERR | MACRO | \$-SELECT | MENU

5. MDS-A/B-V1 Servo Drive

(2) Explanation of parameters

| | | |
|--|----------|---|
| Setting class | ◎ | Set on the [SERVO PARAM] screen. |
| | ○ | Set on the [SERVO PARAM] screen. |
| Compatible from M300 to MDS-A and compatible from MDS-A to MDS-B | ◎ | Setting same data is okay. |
| | ○ | Setting same data is okay (only the setting increment changes). |
| | △ | The meaning of the data is the same but the setting unit changes. |
| | □ | Includes new parameters |
| | ■ | Same setting is okay (some details have been changed) |
| | × | Incompatible |
| | No mark | New parameters |
| - | Not used | |

| | | |
|---------------|---------|--|
| Change method | PR | Turn NC power off and on after setting. |
| | No mark | The power does not need to be turned off and on. |

| No. | Parameter abbr. | Parameter name | Setting class | Compatibility with M300 to MDS-A | Compatibility with MDS-A to MDS-B | Change method | Setting procedure | Standard setting value | Setting range |
|-------|-----------------|-------------------------|---------------|----------------------------------|-----------------------------------|---------------|---|------------------------|---|
| SV001 | PC1 | Motor side gear ratio | ◎ | ◎ | ◎ | PR | Set the No. of gear teeth on the motor side. Set so that PC1 and PC2 have the smallest integer ratio. (Refer to supplement explanation.) | Machine specifications | 1 ~ 30 (32767) Refer to supplement explanation |
| SV002 | PC2 | Machine side gear ratio | ◎ | ◎ | ◎ | PR | Set the No. of gear teeth on the machine side. Set so that PC1 and PC2 have the smallest integer ratio. (Refer to supplement explanation.) | Machine specifications | 1 ~ 30 (32767) Refer to supplement explanation |
| SV003 | PGN1 | Position loop gain 1 | ◎ | ○ | ◎ | | Set the position loop gain. The scale unit is 1 (0.25 in M300). Normally set to 33.0. | 33 | 1 ~ 200 (rad/sec [1/sec]) |
| SV004 | PGN2 | Position loop gain 2 | ○ | △ | ◎ | | When performing SHG control, also set SV057: SHGC. Set to 0 when not using. | 0 | 1 ~ 999 (rad/sec [1/sec]) |
| SV005 | VGN1 | Speed loop gain 1 | ○ | ◎ | ◎ | | Set the speed loop gain. The standard value is 150, and when set higher the response will also increase as will the vibration and sound. | 150 | 1 ~ 999 |
| SV006 | VGN2 | Speed loop gain 2 | | ◎ | ◎ | | If the noise during high-speed rotation such as rapid traverse, set the speed loop gain (smaller than VGN1) for the high-speed (1.2 times the rated speed). Use this parameter with speed gain drop start speed SV029:VCS. Set to 0 when not using. | 0 | -1000 ~ 1000 |

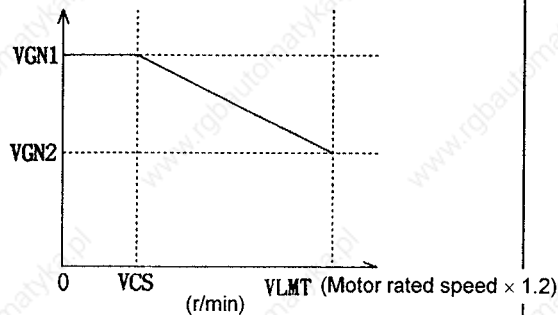

5. MDS-A/B-V1 Servo Drive

| No. | Parameter abbr. | Parameter name | Setting class | Compatibility with M300 to MDS-A | Compatibility with MDS-A to MDS-B | Change method | Setting procedure | Standard setting value | Setting range | | | | | | | | | | | | |
|--------------------------------------|-----------------|--|---------------|----------------------------------|-----------------------------------|--|--|--------------------------------------|-----------------------------|-------------|-------|---|--|------|----|-----|------|----|-----|---|----------------------------|
| SV007 | VIL | Speed loop delay compensation | ○ | △ | ◎ | | <p>Set if a limit cycle occurs in the closed loop or if overshooting occurs during positioning. This is invalid when set to 0. Related parameters: SV027-bit0, 1 Data setting handling expression: VIL(M500) = 3.28 * (10000 - VIL(M300))</p> <p>Example of setting handling</p> <table border="1" style="margin-left: 20px;"> <thead> <tr> <th>M300 setting</th> <th>M500 setting</th> <th>f (rad/s)</th> </tr> </thead> <tbody> <tr> <td>10000</td> <td>0</td> <td></td> </tr> <tr> <td>9990</td> <td>33</td> <td>1.1</td> </tr> <tr> <td>9980</td> <td>66</td> <td>2.2</td> </tr> </tbody> </table> | M300 setting | M500 setting | f (rad/s) | 10000 | 0 | | 9990 | 33 | 1.1 | 9980 | 66 | 2.2 | 0 | 0 ~ 32767 (0.034 rad/s) |
| M300 setting | M500 setting | f (rad/s) | | | | | | | | | | | | | | | | | | | |
| 10000 | 0 | | | | | | | | | | | | | | | | | | | | |
| 9990 | 33 | 1.1 | | | | | | | | | | | | | | | | | | | |
| 9980 | 66 | 2.2 | | | | | | | | | | | | | | | | | | | |
| SV008 | VIA | Speed loop advance compensation | ○ | ◎ | ◎ | | Set the speed loop integral gain. | 1364 | 11 ~ 9999 (0.0687 rad/s) | | | | | | | | | | | | |
| SV009 | IQA | Current loop q axis advance compensation | | ◎ | ◎ | | Set the current control gain. The setting data is fixed by the motor used. (Refer to supplement explanation (5) Standard parameters per motor.) | Motor | 1 ~ 20480 | | | | | | | | | | | | |
| SV010 | IDA | Current loop d axis advance compensation | | ◎ | ◎ | 1 ~ 20480 | | | | | | | | | | | | | | | |
| SV011 | IQG | Current loop q axis gain | | ◎ | ◎ | 1 ~ 2560 | | | | | | | | | | | | | | | |
| SV012 | IDG | Current loop d axis gain | | ◎ | ◎ | 1 ~ 2560 | | | | | | | | | | | | | | | |
| SV013 | ILMT1 | Current limit value 1 | | △ | ◎ | Set the normal current limit value (limit value for both ± directions). Set the percentage (%) for the stall rated current. Set 500 to use the amplifier to the max. torque. (Refer to supplement explanation.) | | | 500 | 0 ~ 500 (%) | | | | | | | | | | | |
| SV014 | ILMT2 | Current limit value 2 | | × | ◎ | Set the current limit value for the absolute position initialization setting (push). (Set the limit value for both ± directions.) Set the percentage (%) for the stall rated current. Set to 0 when not using. | 0 | 0 ~ 500 (%) | | | | | | | | | | | | | |
| SV015 | FFC | Acceleration feed forward gain | ○ | △ | ◎ | | Set this when the overshooting amount during feed forward control or the relative error during synchronous control, etc. is large. Set to 0 when not using. The guideline for the setting is explained later. | 0 | 0 ~ 1000 | | | | | | | | | | | | |
| SV016 | LMC1 | Lost motion compensation gain 1 | ○ | △ | ◎ | | <p>Set this when the protrusions at the quadrant cut-off time (caused by non-sensitive area due to friction, twisting, backlash, etc.) are large. When sv041: LMC2 is 0, LMC1 is valid when both + → -, - → + commands are reversed. When sv041: LMC2 is other than 0, this will be the lost motion compensation gain when the LCM1 - → + command is reversed. (LMC2 is the + → - command reversed gain). If sv041 : LMC2 is -1, LMC1 will be the gain when the - → + command is reversed, and the compensation will be invalid when the + → - command is reversed.</p> <p>Definition of command direction +, - : Machine parameters (basic specifications) When 8. CCW is 0 : +, - in program match When 8. CCW is 1 : +, - in program are opposite. Refer to the setting examples (given later).</p> <table border="1" style="margin-left: 20px;"> <tr> <td>Type 1 (when sv027 : SSF1-bit8 is 1)</td> </tr> </table> <p>The protrusions will be eliminated with this type of compensation during low-speed interpolation. The compensation gain is 0. When 100 is set, a 100% compensation will be executed. (Type used in M300 Series.)</p> | Type 1 (when sv027 : SSF1-bit8 is 1) | 0 | 0 ~ 200 (%) | | | | | | | | | | | |
| Type 1 (when sv027 : SSF1-bit8 is 1) | | | | | | | | | | | | | | | | | | | | | |

5. MDS-A/B-V1 Servo Drive

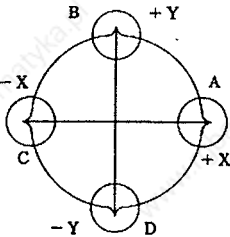
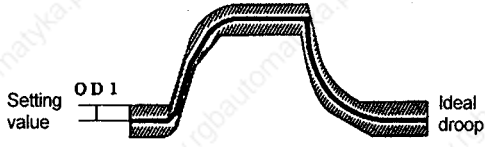
| No. | Parameter abbr. | Parameter name | Setting class | Compatibility with M300 to MDS-A | Compatibility with MDS-A to MDS-B | Change method | Setting procedure | Standard setting value | Setting range | | | | | | | | | | | | | | | | | | | | | | | | | | | | | |
|-------|-----------------|--|---------------|----------------------------------|-----------------------------------|---------------|---|------------------------|------------------------|--|-----|--|----|-----|----|-----|---|-------|-------|-------|-------|---|-------|-------|-------|-------|---|-------|-------|-------|-------|---|-------|-------|-------|-------|---|-------------|
| SV016 | LMC1 | Lost motion compensation gain 1 | ○ | △ | ◎ | | <p>Type 2 (when sv027 : SSF1-bit9 is 1)</p> <p>This type is the standard in the M500 Series. This type is used when ample compensation is not possible with type 1 during high-speed high precision interpolation. Set with a % for the stall rated current. Compensation will not be performed when this is set to 0. Set a value that is double the current % displayed on the [SERVO MONITOR] screen during JOG feed (approx. F1000).</p> <div style="display: flex; justify-content: space-around; align-items: center;">  <table border="1" style="border-collapse: collapse; text-align: center;"> <thead> <tr> <th rowspan="2">X</th> <th colspan="2">CW</th> <th colspan="2">CCW</th> </tr> <tr> <th>CW</th> <th>CCW</th> <th>CW</th> <th>CCW</th> </tr> </thead> <tbody> <tr> <td>A</td> <td>+ → -</td> <td>+ → -</td> <td>- → +</td> <td>- → +</td> </tr> <tr> <td>B</td> <td>+ → -</td> <td>- → +</td> <td>+ → -</td> <td>- → +</td> </tr> <tr> <td>C</td> <td>- → +</td> <td>- → +</td> <td>+ → -</td> <td>+ → -</td> </tr> <tr> <td>D</td> <td>- → +</td> <td>+ → -</td> <td>- → +</td> <td>+ → -</td> </tr> </tbody> </table> </div> | X | CW | | CCW | | CW | CCW | CW | CCW | A | + → - | + → - | - → + | - → + | B | + → - | - → + | + → - | - → + | C | - → + | - → + | + → - | + → - | D | - → + | + → - | - → + | + → - | 0 | 0 ~ 100 (%) |
| X | CW | | CCW | | | | | | | | | | | | | | | | | | | | | | | | | | | | | | | | | | | |
| | CW | CCW | CW | CCW | | | | | | | | | | | | | | | | | | | | | | | | | | | | | | | | | | |
| A | + → - | + → - | - → + | - → + | | | | | | | | | | | | | | | | | | | | | | | | | | | | | | | | | | |
| B | + → - | - → + | + → - | - → + | | | | | | | | | | | | | | | | | | | | | | | | | | | | | | | | | | |
| C | - → + | - → + | + → - | + → - | | | | | | | | | | | | | | | | | | | | | | | | | | | | | | | | | | |
| D | - → + | + → - | - → + | + → - | | | | | | | | | | | | | | | | | | | | | | | | | | | | | | | | | | |
| SV017 | SPEC | Servo system specifications | ◎ | × | □ | PR | Set the servo system specifications with the bits. Refer to the section "Parameter details". | 0 | HEX | | | | | | | | | | | | | | | | | | | | | | | | | | | | | |
| SV018 | PIT | Ball screw pitch. | ◎ | ◎ | ◎ | PR | Set the ball screw pitch. | Machine specifications | 1 ~ 32767 (mm) | | | | | | | | | | | | | | | | | | | | | | | | | | | | | |
| SV019 | RNG1 | Position detector resolution | ◎ | ◎ | ◎ | PR | Set a value that is the No. of pulses (k pulse) per position control detector rotation times four. (Refer to the section "Parameter details".) For semi-closed : Set a value that is the No. of pulses (k pulses) per motor rotation times four. (RNG1 = RNG2) For closed : Set the No. of pulses per ball screw pitch. | Detector | 1 ~ 1000 kp/rev | | | | | | | | | | | | | | | | | | | | | | | | | | | | | |
| SV020 | RNG2 | Speed detector resolution | ◎ | | ◎ | PR | Set the No. of pulses per motor shaft detector rotation. (Refer to the RNG1 setting.) | Detector | 1 ~ 1000 kp/rev | | | | | | | | | | | | | | | | | | | | | | | | | | | | | |
| SV021 | OLT | Overload time constant | | △ | ■ | | Set the time constant for overload 1 (OL1) detection. (Unit: 1sec.) (The setting unit in M300 was 0.1 sec.) | 60 | 1 ~ 300 (sec) | | | | | | | | | | | | | | | | | | | | | | | | | | | | | |
| SV022 | OLL | Overload detection level | | ◎ | ■ | | Set the overload 1 (OL1) current detection level with a percentage (%) of the stall rating. | 150 | 1 ~ 500 (%) | | | | | | | | | | | | | | | | | | | | | | | | | | | | | |
| SV023 | OD1 | Excessive error width 1 (during servo ON) | | △ | ◎ | | Set the excessive error width during servo ON. (The setting unit in the M300 was an interpolation unit.) Setting equation: $OD1 = OD2 = \frac{F}{60 \cdot PGN1} \cdot 0.5 \text{ (mm)}$  | Machine specifications | 1 ~ 32767 (mm) | | | | | | | | | | | | | | | | | | | | | | | | | | | | | |
| SV024 | INP | In-position width | | △ | ◎ | | Set the in-position width (μm). (The setting unit in the M300 was an interpolation unit.) | 50 | 0 ~ 32767 (μm) | | | | | | | | | | | | | | | | | | | | | | | | | | | | | |
| SV025 | MTYP | Motor type | ◎ | △ | □ | PR | Refer to the section "Parameter details". | | HEX | | | | | | | | | | | | | | | | | | | | | | | | | | | | | |
| SV026 | OD2 | Excessive error width 2 (during servo OFF) | | △ | ◎ | | Set the excessive error width during servo OFF. (Normally the same data as OD1 is set). (The setting unit in the M300 was an interpolation unit.) | Machine specifications | 0 ~ 32767 (mm) | | | | | | | | | | | | | | | | | | | | | | | | | | | | | |
| SV027 | SSF1 | Servo function 1 | ◎ | × | □ | | Use this to select the servo functions. Refer to the section "Parameter details". | Machine specifications | HEX | | | | | | | | | | | | | | | | | | | | | | | | | | | | | |
| SV028 | | | | | - | | Not used | 0 | | | | | | | | | | | | | | | | | | | | | | | | | | | | | | |
| SV029 | VCS | Speed loop gain change start speed | | ◎ | ◎ | | When using the speed loop gain variable function, the motor speed for changing the gain is set in 0.1r/min units. Set to 0 when not using. Related parameter: sv006:VGN2 | 0 | -32768 ~ 32767 (r/min) | | | | | | | | | | | | | | | | | | | | | | | | | | | | | |
| SV030 | | | | | - | | Not used | 0 | | | | | | | | | | | | | | | | | | | | | | | | | | | | | | |

5. MDS-A/B-V1 Servo Drive

| No. | Parameter abbr. | Parameter name | Setting class | Compatibility with M300 to MDS-A | Compatibility with MDS-A to MDS-B | Change method | Setting procedure | Standard setting value | Setting range |
|-------|-----------------|---------------------------------|---------------|----------------------------------|-----------------------------------|---------------|--|------------------------|----------------|
| SV031 | OVS1 | Overshoot compensation gain 1 | ○ | ◎ | ◎ | | <p>Set this when overshooting occurs during deceleration stop in submicron control or closed control, etc. (Valid when 27. SSF1-bitA=1.)</p> <p>The overshooting will be suppressed when the setting is raised. The normal setting value is 2 to 10% (ratio to stall rated current). (Increase in 2% steps and find the value where overshooting does not occur.)</p> <p>Valid for both + and – directions when SV042:OVS2 is 0. Valid only in + direction when SV042:OVS2 is not 0. (OVS2 is compensation gain for – direction movement.) Refer to the supplement explanation for the definition of the + and – directions.</p> | 0 | 0 ~ 100 (%) |
| SV032 | TOF | Torque offset compensation gain | ○ | △ | ◎ | | <p>The unbalance torque amount for axes requiring an unbalanced torque, such as the vertical axis, is set with a percentage to stall rated current. (In the M300 Series, the setting of a minus value was the difference from 65536. In M500, the value is set as is. Example: – 20.)</p> <p>This is used when the SSF1 lost motion compensation 1, 2 or closed loop response improvement is set.</p> <p>Feed in the + and – directions with the low JOG speed (approx. F200) while watching the current load (%) on the [PLC-I/F] screen servo monitor. Check the maximum value if the current load is positive and the minimum if the value is negative, and set the average value for the + and – direction values.</p> | 0 | –100 ~ 100 (%) |

5. MDS-A/B-V1 Servo Drive

The following parameters are new parameters for the M500 Series.

| No. | Parameter abbr. | Parameter name | Setting class | Compatibility with M300 to MDS-A | Compatibility with MDS-A to MDS-B | Change method | Setting procedure | Standard setting value | Setting range |
|-------|-----------------|--|---------------|----------------------------------|-----------------------------------|---------------|---|------------------------|---------------------------|
| SV033 | SSF2 | Servo function 2 | ☉ | | ☐ | | Refer to the section "Parameter details". | 0 | HEX |
| SV034 | SSF3 | Servo function 3 | | - | ☐ | | Refer to the section "Parameter details". | 0 | HEX |
| SV035 | SSF4 | Servo function 4 | | - | ☐ | | Refer to the section "Parameter details". | 0 | HEX |
| SV036 | PTYP | Power supply type | ☉ | | ☐ | PR | Set only the axis connected to the power supply. (Axis connected with CN4 cable.) (Set 0 when no axis is connected.) Refer to the section "Parameter details". | | |
| SV037 | JL | Motor conversion inertia amount | ○ | | ☉ | | Set the inertia amount for motor conversion. This will be ignored when set to 0. (Not used currently.) | 0 | 0 ~ 5000 (%) |
| SV038 | FHZ | Machine resonance suppressing filter frequency | ○ | | ☉ | | Set the vibration frequency to be suppressed when the machine vibrates. However, this is limited to frequencies that are 100Hz and higher. Set to 0 when not using. | 0 | 0 ~ 3000 (Hz) |
| SV039 | | | | - | - | | Not used | 0 | |
| SV040 | LMCT | Lost motion compensation non-sensitive band | | | ☉ | | Set the non-sensitive band for lost motion compensation. Normally, 0 is set. This is set only when the lost motion compensation timing does not match during feed forward control. | 0 | 0 ~ 100 (μm) |
| SV041 | LMC2 | Lost motion compensation gain 2 | ○ | | ☉ | | Set the lost motion compensation gain for + → - (command direction CW). (This is used only when the compensation amount is to be changed according to the direction. If the setting is 0, LMC1 will be valid for both directions.) Refer to the supplement explanation. | 0 | -1 ~ 200 (%) |
| SV042 | OVS2 | Overshoot compensation gain 2 | ○ | | ☉ | | Set the overshoot compensation gain for the - direction movement (command direction CW). (This is used only when the compensation amount is to be changed according to the direction. If the setting is 0, OVS1 will be valid for both directions.) This is valid when the 27. SSF1 ovst1 (bitA) is valid. | 0 | -1 ~ 200 (%) |
| SV043 | OBS1 | Observer 1 | | | ☉ | | Observer 1 Set the observer pole. Normally, approx. 628 (rad) is set. Set sv037:JL and sv044:OBS2 to activate the observer function. Set 0 when not required. | 0 | 0 ~ 1000 (rad) |
| SV044 | OBS2 | Observer 2 | | | ☉ | | Observer 2 Set the observer execution gain. Normally, 100 is set. Set sv037:JL and sv043:OBS1 to activate the observer function. Set to 0 when not required. | 0 | 0 ~ 500 (%) |
| SV045 | TRUB | Frictional torque | | - | | | Set the frictional torque as a percentage in respect to the stall rated current when using the collision detection function. Set to 0 when not using the collision detection function. | 0 | 0 ~ 100 (%) |
| SV046 | | | | - | - | | Not used | 0 | |
| SV047 | EC1 | Induction voltage compensation | | | ☉ | | Induction voltage compensation Set the induction voltage compensation execution gain. Normally, 100 is set. | 100 | -32768 ~ 32767 (%) |
| SV048 | EMGr | Brake operation delay time | | - | | | Set the brake operation delay time when using the drop prevention function. Set a value that is larger than the actual brake operation time. Set to 0 when not using the drop prevention function. | 0 | 0 ~ 2000 (msec) |
| SV049 | PGN1SP | Spindle synchronous position loop gain 1 | | | ☉ | | Set the position loop gain to synchronize the servo when moving the spindle position loop during synchronous tap, etc. | 15 | 0 ~ 200 (rad/sec [1/sec]) |
| SV050 | PGN2SP | Spindle synchronous position loop gain 2 | | | ☉ | | Set this when using SHG control during spindle synchronous control. Set to 0 when not using. | 0 | 0 ~ 999 (rad/sec [1/sec]) |
| SV051 | DFBT | Dual control time constant | | | ☉ | | Set the compensation time constant for dual feed back control. | 0 | 0 ~ 9999 (ms) |
| SV052 | DFBN | Dual control non-sensitive band width | | | ☉ | | Set the non-sensitive band amount for dual feed back control. | 0 | 0 ~ 9999 (μm) |
| SV053 | OD3 | Excessive error width 3 | | | ☉ | | Set the excessive error width for special operations such as pushing. | 0 | 0 ~ 32767 (mm) |
| SV054 | ORE | Closed loop overrun detection width | | | ☉ | | Set the over-run detection width during closed loop. (For alarm 43 detection.) Multiply the SV023 OD1 (excessive error width) value by 1.2, cut off the fractions, and set the value. Set to 0 when not using. | 0 | -1 ~ 32767 (mm) |

5. MDS-A/B-V1 Servo Drive

| No. | Parameter abbr. | Parameter name | Setting class | Compatibility with M300 to MDS-A | Compatibility with MDS-A to MDS-B | Change method | Setting procedure | Standard setting value | Setting range |
|-------|-----------------|--|---------------|----------------------------------|-----------------------------------|---------------|--|------------------------|---------------------------|
| SV055 | EMGx | Emergency stop max. delay time | | - | | | Set the max. delay time for emergency stop when using the drop prevention function. Normally, the same value as sv056:EMGt is set. Set to 0 when not using the drop prevention function. | 0 | 0 ~ 2000 (msec) |
| SV056 | EMGt | Emergency stop deceleration time constant | | - | | | Set the deceleration time constant from the max. rapid traverse rate to be applied when using the drop prevention function. Normally, the same value as the CNC G0 acceleration/ deceleration time constant. Set to 0 when not using the drop prevention function. | 0 | 0 ~ 2000 (m/sec) |
| SV057 | SHGC | High gain control constant | | | ⊙ | | Set this when using SHG control. Set this with sv004: PGN2. Set to 0 when not required. | 0 | 0 ~ 999 (rad/sec [1/sec]) |
| SV058 | SHGCSP | High gain constant for spindle synchronization | | | ⊙ | | Set when using SHG control for special operations (synchronous tapping, interpolation with spindle C axis, etc.). Set this with sv050:PGN2sp. Set to 0 when not required. | 0 | 0 ~ 999 (rad/sec [1/sec]) |
| SV059 | TCNV | Torque estimation gain | | - | | | Set the estimated torque gain to be applied when using the collision detection function. By setting sv035:SSF4/clt to 1, the setting value guideline can be displayed at MPOF on the servo monitor screen. Set to 0 when not using the collision detection function. | 0 | 0 ~ 32767 |
| SV060 | TLMT | G0 collision detection level | | - | | | Set the method 1 G0 modal collision detection level as a percentage in respect to the stall rated current when using the collision detection function. Set to 0 when not using the collision detection function. | 0 | 0 ~ 500 (%) |
| SV061 | DA1NO | D/A output channel 1 data No. | | | ⊙ | | Set the output data No. for the channel 1 of the D/A output function. If -1 is set, D/A output of that axis will not be carried out. | 0 | |
| SV062 | DA2NO | D/A output channel 2 data No. | | | ⊙ | | Set the output data No. for the channel 2 of the D/A output function. If -1 is set, D/A output of that axis will not be carried out. | 0 | |
| SV063 | DA1MPY | D/A output channel 1 magnification | | | ⊙ | | Set the output magnification for channel 1 of the D/A output function. The output magnification is the (setting value)/256. If 0 is set, it will be interpreted that 256 is set. (Output magnification: 1-fold) | 0 | |
| SV064 | DA2MPY | D/A output channel 2 magnification | | | ⊙ | | Set the output magnification for channel 2 of the D/A output function. The output magnification is the (setting value)/256. If 0 is set, it will be interpreted that 256 is set. (Output magnification: 1-fold) | 0 | |

5. MDS-A/B-V1 Servo Drive

(3) Parameter details

sv015 FFC Acceleration feed forward gain

Refer to the following table, calculate FFC, and set the value. Then, increment the value by +10% at a time until the effect is seen. The upper limit is two times the initial value.

$$FFC = A * (1 + JL/JM)$$

Where, JL is the motor axis conversion load inertia.

JM is the motor rotor inertia.

A is set from the following table according to the motor model name.

| Motor model name | A | Motor model name | A | Motor model name | A |
|------------------|-----|------------------|-----|------------------|-----|
| HA23 | 55 | HA50NL | 30 | HA-LH11K2 | 100 |
| HA33 | 65 | HA53NL | 25 | HA-LH15K2 | 160 |
| HA40 | 100 | HA100NL | 35 | | |
| HA43 | 140 | HA103NL | 30 | | |
| HA80 | 110 | HA150NL | 55 | | |
| HA83 | 145 | HA153NL | 50 | | |
| HA100 | 235 | HA200NL | 85 | | |
| HA103 | 250 | HA203NL | 70 | | |
| HA200 | 320 | HA300NL | 80 | | |
| HA300 | 320 | HA303NL | 70 | | |
| HA700 | 310 | HA500NL | 175 | | |
| HA900 | 300 | HA503NL | 155 | | |

Note) All bits not used including empty bits are all set to 0 in the following bit explanation.

sv017 SPEC

Servo specifications

| | | | | | | | | | | | | | | | |
|---|---|---|---|---|---|------|----|-----|---|------|------|---|---|------|---|
| F | E | D | C | B | A | 9 | 8 | 7 | 6 | 5 | 4 | 3 | 2 | 1 | 0 |
| | | | | | | mpt3 | mp | abs | | vdir | fdir | | | dfbx | |

| bit | Name | Meaning when set to 0 | Meaning when set to 1 |
|-----|------|---|--|
| 0 | | | |
| 1 | dfbx | Dual feedback control invalid | Dual feedback control valid |
| 2 | | | |
| 3 | | | |
| 4 | fdir | Position feedback positive polarity | Position feedback negative polarity |
| 5 | vdir | Motor end detector installation direction AC | Motor end detector installation direction BD |
| 6 | | | |
| 7 | abs | Relative position detection | Absolute position detection |
| 8 | mp | MP scale 360P (2mm pitch) | MP scale 720P (1mm pitch) |
| 9 | mpt3 | MP scale absolute position detection type 1/2 selection | MP scale absolute position detection type 3 election |
| A | | | |
| B | | | |
| C | | | |
| D | | | |
| E | | | |
| F | | | |

5. MDS-A/B-V1 Servo Drive

bit5 vdir Polarity position detector installation direction B, D
 If installation direction B or D are used for the small capacity motor (HA23N/33N)
 set this bit to 1.
 Always set this bit to 0 for other motors.

Use the standard A detection to prevent incorrect settings.

0 : Polarity position detector installation direction A, C
 1 : Polarity position detector installation direction B, D

Detector connector orientation symbols (A direction is used as a standard.)

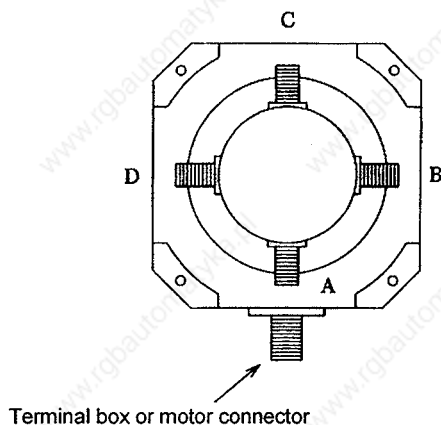

sv019 RNG1 Position detector resolution

sv020 RNG2 Speed detector resolution

| Motor capacity | p/rev | Position/speed detector | RNG1 | RNG2 |
|----------------|--------------------|--|------------------|------|
| 50/100W | 2500 | HA053/HA13 Motor built-in detector | 10 | 10 |
| 200W or more | 25000 | OHE25K-6/OSE104 OHE25K-85/OSE104S OHA25K-4/OSA104 OHA25K-85/OSA104S | 100 | 100 |
| 200W or more | 25000 (100,000) | OHE25K-ET/OSE104ET OHA25K-ET/OSA104ET | 100 | X |
| 200W or more | (1,000,000) | OSE105/OSE105S OSA105/OSA105S | 1000 | 1000 |
| Linear scale | | | PIT | X |
| Induct-syn | | | Scale resolution | |

X : Set the parameter (10 or 100, 1000) corresponding to the relevant motor end detector model name.

5. MDS-A/B-V1 Servo Drive

sv025 MTYP Motor and detector type

| | | | | | | | | | | | | | | | |
|-----|---|---|---|-----|---|---|---|------|---|---|---|---|---|---|---|
| F | E | D | C | B | A | 9 | 8 | 7 | 6 | 5 | 4 | 3 | 2 | 1 | 0 |
| PEN | | | | ENT | | | | MTYP | | | | | | | |

PEN Position detector type
(Set the model name of the detector being used from the following table)

ENT Speed detector type
(Set the model name of the detector being used from the following table)

| Class | Detection method | Detector model name | PEN | ENT |
|-------------------------|-----------------------|--|-----|-----|
| Motor end detector | Relative value | OHE25K-6, OHE25K-85/OSE104, OSE104S | 0 | 0 |
| | Absolute value | OHA25K-4, OHA25K-85/OA104, OA104S | 1 | 1 |
| | High-speed serial | OSA105/OSE105 | 2 | 2 |
| | Relative value | HA053/13 Motor built-in encoder | 3 | 3 |
| Ball screw end detector | Relative value | OHE25K-ET/OSE104ET | 4 | X |
| | Absolute value | OHA25K-ET/OA104ET | 5 | X |
| | High-speed serial | OSA105ET/OSE105ET | 6 | X |
| | | | 7 | X |
| Machine end detector | A, B, Z-phase | Optical scale, magnetic scale, MP scale (induct-syn) | 8 | X |
| | Serial absolute value | Mitsutoyo absolute value linear scale AT41, Soshin Electric FME type, FLE type | 9 | X |
| | High-speed serial | Mitsutoyo absolute value linear scale AT342 | A | X |
| | | | B | X |

X : Set the "ENT" value (0 to 3) in the table corresponding to the relevant motor end detector model name.

* : When using the 100,000 pulse serial pulse encoder the same parameter settings as the conventional type (OHA-25K/OHE-25K) are used.

MTYP Motor type (Select the motor model name from the following table.)

| Motor series | 2000rpm Standard | 2000rpm Flat | 2000rpm Low inertia | 3000rpm Low inertia | 3000rpm Ultra-low inertia | 3000rpm Special | 3000rpm General-purpose | 3000rpm Standard | |
|--------------|------------------|--------------|---------------------|---------------------|---------------------------|-----------------|-------------------------|------------------|--------|
| No. | 0x | 1x | 2x | 3x | 4x | 5x | 6x | 7x | 8x |
| x0 | HA40N | HA50U | HA50NL | HA53NL | HA43LN | | HA-N43 | HA-FE43 | HA43N |
| x1 | HA80N | HA100U | HA100NL | HA103NL | HA83LN | | | HA-FE63 | HA83N |
| x2 | HA100N | HA200U | HA200NL | HA203NL | HA103LN | | | | HA103N |
| x3 | HA200N | HA300U | HA300NL | HA303NL | HA203LN | | | | HA203N |
| x4 | HA300N | HA500U | HA500NL | HA503NL | HA303LN | | | | HA303N |
| x5 | HA700N | | | | | | | | HA703N |
| x6 | HA900N | | | | | | | | |
| x7 | | | HA-LH11K2 | | | | | | |
| x8 | | | HA-LH15K2 | | | | | | |
| x9 | | | | | | | | | |
| xA | | HA150U | HA150NL | HA153NL | HA93LN | | | | |
| xB | | | | | | | | | |
| xC | | | | | | | | HA-FE053 | HA053 |
| xD | | | | | | | | HA-FE13 | HA13 |
| xE | | | | | | | HA-N23 | HA-FE23 | HA23N |
| xF | | HA30U | | | | | HA-N33 | HA-FE33 | HA33N |

Note : Types indicates as HA-FE in the table include HA-FH.

5. MDS-A/B-V1 Servo Drive

sv027 SSF1

Special servo function selection 1

| | | | | | | | | | | | | | | | |
|------|------|---|---|------|------|------|------|---|---|-------|-------|---|-----|-------|-------|
| F | E | D | C | B | A | 9 | 8 | 7 | 6 | 5 | 4 | 3 | 2 | 1 | 0 |
| aflt | zrn2 | | | ovs2 | ovs1 | lmc2 | lmc1 | | | vfct2 | vfct1 | | upc | vcnt2 | vcnt1 |

| bit | Name | Meaning when set to 0 | Meaning when set to 1 | Usage | |
|-----|-------|---|--|-------|-------|
| | | | | MDS-A | MDS-B |
| 0 | vcnt1 | 00: Delay compensation changeover invalid | 10: Delay compensation changeover type 2 | ○ | ○ |
| 1 | vcnt2 | 01: Delay compensation changeover type 1 | 11: Reserved | ○ | ○ |
| 2 | upc | Starting torque compensation invalid | Starting torque compensation valid | × | ○ |
| 3 | | | | - | - |
| 4 | vfct1 | 00: Jitter compensation invalid | 10: Jitter compensation 2 pulse | ○ | ○ |
| 5 | vfct2 | 01: Jitter compensation 1 pulse | 11: Jitter compensation 3 pulse | ○ | ○ |
| 6 | | | | - | - |
| 7 | | | | - | - |
| 8 | lmc1 | 00: Lost motion compensation invalid | 10: Lost motion compensation type 2 | ○ | ○ |
| 9 | lmc2 | 01: Lost motion compensation type 1 | 11: Reserved | ○ | ○ |
| A | ovs1 | 00: Overshoot compensation invalid | 01: Overshoot compensation type 2 | ○ | ○ |
| B | ovs2 | 01: Overshoot compensation type 1 | 11: Reserved | ○ | ○ |
| C | | | | - | - |
| D | | | | - | - |
| E | zrn2 | Reference point return type 1 | Reference point return type 2 | ○ | ○ |
| F | aflt | Adaptive filter invalid | Adaptive filter valid | ○ | ○ |

Note) Bit E is set to 1 when the power is turned ON. Do not change this bit.

bit0 vcnt1 bit1 vcnt2 Speed loop delay compensation type
Overshooting and limit cycle, etc., will be prevented during the closed loop.
Use this in combination with sv007: VIL.
When used, type 1 is the standard.

bit4 vfct1 bit5 vfct2 Speed feed back compensation (jitter compensation)
The jittering during light loads is compensated.

bit8 lmc1 bit9 lmc2 Lost motion compensation type
The compensation gain is set with sv016:LMC1 and sv041:LMC2.
When used, type 2 is the standard.

bitA ovst1 Overshoot compensation
The compensation gain is set with sv031:OVS1 and sv042:OVS2.

bitF aflt Adaptive filter
The resonance frequency is detected when machine vibration occurs, and the filter is automatically set to remove the vibration. This is effective for resonance exceeding 100Hz.

5. MDS-A/B-V1 Servo Drive

sv033 SSF2

Special servo function selection 2

| | | | | | | | | | | | | | | | |
|---|---|---|---|---|---|---|---|---|---|---|---|---|---|---|-----|
| F | E | D | C | B | A | 9 | 8 | 7 | 6 | 5 | 4 | 3 | 2 | 1 | 0 |
| | | | | | | | | | | | | | | | zck |

| bit | Name | Meaning when set to 0 | Meaning when set to 1 |
|-----|------|--|-----------------------|
| 0 | zck | Z phase check valid (part of alarm 42) | Z phase check invalid |
| 1 | | | |
| 2 | | | |
| 3 | | | |
| 4 | | | |
| 5 | | | |
| 6 | | | |
| 7 | | | |
| 8 | | | |
| 9 | | | |
| A | | | |
| B | | | |
| C | | | |
| D | | | |
| E | | | |
| F | | | |

sv036 PTYP

| | | | | | | | | | | | | | | | |
|---|---|---|---|---|---|---|---|---|---|---|---|---|---|------|---|
| F | E | D | C | B | A | 9 | 8 | 7 | 6 | 5 | 4 | 3 | 2 | 1 | 0 |
| | | | | | | | | | | | | | | ptyp | |

ptyp Power supply type (Set model name from following table)

| Power supply type | ptyp | |
|-------------------|------|--|
| Not connected | 00 | Set only the axis connected to the power supply. (Set 0 if no axis is connected.) If the 2-axis integrated amplifier is connected to the power supply, set both the L axis and M axis to the same parameter. |
| CV-37 | 04 | |
| CV-55 | 06 | |
| CV-75 | 08 | |
| CV-110 | 11 | |
| CV-150 | 15 | |
| CV-185 | 19 | |
| CV-220 | 22 | |
| CV-260 | 26 | |
| CV-300 | 30 | |
| CV-370 | 37 | |

* The above settings are the standard settings for CV. When using special settings, CR or CSP, refer to Chapter 2 Power supply section and Chapter 4 CPS Large capacity spindle drive section.

(4) Supplement explanation

- (a) Lost motion and overshooting compensation + and – directions
 Confirm the [BASE SPEC. PARAM] M-PARAM 8.ccw.

When parameter ccw = 0: The + and – directions in the program match the + and – compensation directions.

When parameter ccw = 1: The + and – directions in the program are opposite to the + and – compensation directions.

(Example of lost motion compensation) When applying lost motion compensation on the X axis direction

JOG feed was executed at F500 to F1000, and when the current value on the [NC MONITOR] screen was confirmed the current value was 20%. However, there is a difference in the protrusion amount so the A point compensation amount is to be set to 40% and the C point compensation amount to 50%.

If parameter ccw is 0, set 50 in LMC1 and 40 in LMC2.

If parameter ccw is 1, set 40 in LMC1 and 50 in LMC2.

To set the A point compensation amount to 40% and the C point compensation amount to 0% when ccw is 0, set –1 in LMC1 and 40 in LMC2.

To set the A point compensation amount to 0% and the C point compensation amount to 40%, set 40 in LMC1 and –1 in LMC2.

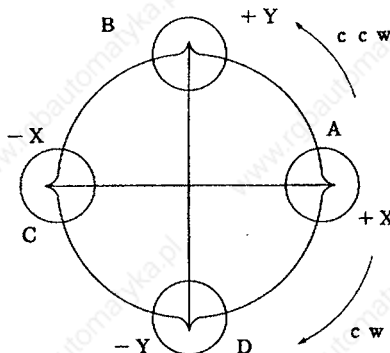

- (b) Limits regarding PC1 and PC2

The setting range of sv001:PC1 and sv002:PC2 is basically 1 to 30. However, if the following conditions are satisfied, a setting of 30 or more is possible.

Note that even when in the range of 1 to 30, the following conditions must be satisfied.

For semi-closed loop $PC1' < 32767/PIT'/IUNIT$
 $PC2' < 32767/RNG1'$

For closed loop $PC1' < 32767/RNG1C/30$
 $PC2' < 32767/RNG2C/PNG1$

Meaning of symbols

- PC1' Valid obtained by dividing PC1 by the max. common divisor of PC2
- PC2' Valid obtained by dividing PC2 by the max. common divisor of PC1
- PIT' Valid obtained by dividing PIT by the max. common divisor of RNG1
- RNG1' Valid obtained by dividing RNG1 by the max. common divisor of PIT
- RNG1C Valid obtained by dividing RNG1 by the max. common divisor of RNG2
- RNG2C Valid obtained by dividing RNG2 by the max. common divisor of RNG1
- IUNIT CNC interpolation unit

| CNC interpolation unit | IUNIT |
|------------------------|-------|
| 0.500μm | 2 |
| 0.050μm | 20 |
| 0.005μm | 200 |

5. MDS-A/B-V1 Servo Drive

(c) Current limits

| Motor | Stall rated current A | Max. current A | Max. torque N·m | % |
|-----------|--------------------------|-------------------|--------------------|-----|
| HA40N | 3.6 | 17 | 14.2 | 472 |
| HA80N | 6.6 | 28 | 25.5 | 424 |
| HA100N | 14 | 42 | 42 | 300 |
| HA200N | 22 | 57 | 60 | 260 |
| HA300N | 37 | 85 | 87 | 230 |
| HA700N | 49 | 113 | 120 | 231 |
| HA900N | 56 | 141 | 153 | 252 |
| HA053 | 1.4 | 3.9 | 0.69 | 279 |
| HA13 | 1.4 | 3.9 | 1.37 | 279 |
| HA23N | 3 | 8.1 | 2.75 | 270 |
| HA33N | 3 | 8.1 | 5.6 | 270 |
| HA43N | 5 | 17 | 10.2 | 340 |
| HA83N | 8.8 | 28 | 19.2 | 318 |
| HA103N | 19.6 | 57 | 40 | 291 |
| HA203N | 34.5 | 85 | 56 | 246 |
| HA303N | 55 | 113 | 80 | 205 |
| HA703N | 68 | 141 | 105 | 207 |
| HA50NL | 4 | 17 | 13.0 | 425 |
| HA100NL | 8 | 28 | 20.9 | 350 |
| HA150NL | 11.5 | 42 | 31 | 365 |
| HA200NL | 18.2 | 42 | 32 | 231 |
| HA300NL | 25 | 57 | 52 | 228 |
| HA500NL | 44 | 85 | 72 | 193 |
| HA53NL | 5.8 | 28 | 14.1 | 482 |
| HA103NL | 11.0 | 42 | 22.5 | 381 |
| HA153NL | 16.2 | 42 | 22.8 | 259 |
| HA203NL | 21 | 57 | 37 | 271 |
| HA303NL | 32 | 85 | 60 | 265 |
| HA503NL | 54 | 113 | 78 | 209 |
| HA-LH11K2 | 84 | 204 | 158 | 242 |
| HA-LH15K2 | 100 | 260 | 215 | 260 |

When sv013 ILMT1 is set to 500(%), the limit will be applied with the maximum current (torque) shown above.

To apply the limit below the maximum current (torque) set the parameter with the percentage (%) to the stall rating.

5. MDS-A/B-V1 Servo Drive

(5) Standard parameters per motor

1. 2000rpm motor

| Parameter | HA40N | HA80N | HA100N | HA200N | HA300N | HA700N | HA900N | | | |
|-----------|--------|-------|--------|--------|--------|--------|--------|------|--|--|
| | Driver | 05 | 10 | 20 | 35 | 45 | 70 | 90 | | |
| sv001 | PC1 | | | | | | | | | |
| 2 | PC2 | | | | | | | | | |
| 3 | PGN1 | 33 | 33 | 33 | 33 | 33 | 25 | 25 | | |
| 4 | PGN2 | 0 | 0 | 0 | 0 | 0 | 0 | 0 | | |
| 5 | VGN1 | 150 | 150 | 150 | 150 | 150 | 250 | 250 | | |
| 6 | VGN2 | 0 | 0 | 0 | 0 | 0 | 0 | 0 | | |
| 7 | VIL | 0 | 0 | 0 | 0 | 0 | 0 | 0 | | |
| 8 | VIA | 1364 | 1364 | 1364 | 1364 | 1364 | 1364 | 1364 | | |
| 9 | IQA | 2048 | 2048 | 1024 | 1024 | 1024 | 1024 | 1024 | | |
| 10 | IDA | 2048 | 2048 | 2048 | 2048 | 2048 | 2048 | 2048 | | |
| 11 | IQG | 512 | 512 | 256 | 256 | 256 | 200 | 200 | | |
| 12 | IDG | 512 | 512 | 512 | 512 | 512 | 256 | 256 | | |
| 13 | ILMT1 | 500 | 500 | 500 | 500 | 500 | 500 | 500 | | |
| 14 | ILMT2 | 0 | 0 | 0 | 0 | 0 | 0 | 0 | | |
| 15 | FFC | 0 | 0 | 0 | 0 | 0 | 0 | 0 | | |
| 16 | LMC1 | 0 | 0 | 0 | 0 | 0 | 0 | 0 | | |
| 17 | SPEC | | | | | | | | | |
| 18 | PIT | | | | | | | | | |
| 19 | RNG1 | | | | | | | | | |
| 20 | RNG2 | | | | | | | | | |
| 21 | OLT | 60 | 60 | 60 | 60 | 60 | 60 | 60 | | |
| 22 | OLL | 150 | 150 | 150 | 150 | 150 | 150 | 150 | | |
| 23 | OD1 | | | | | | | | | |
| 24 | INP | 50 | 50 | 50 | 50 | 50 | 50 | 50 | | |
| 25 | MTYP | XX00 | XX01 | XX02 | XX03 | XX04 | XX05 | XX06 | | |
| 26 | OD2 | | | | | | | | | |
| 27 | SSF1 | 4000 | 4000 | 4000 | 4000 | 4000 | 4000 | 4000 | | |
| 28 | | 0 | 0 | 0 | 0 | 0 | 0 | 0 | | |
| 29 | VCS | 0 | 0 | 0 | 0 | 0 | 0 | 0 | | |
| 30 | | 0 | 0 | 0 | 0 | 0 | 0 | 0 | | |
| 31 | OVS1 | 0 | 0 | 0 | 0 | 0 | 0 | 0 | | |
| 32 | TOF | 0 | 0 | 0 | 0 | 0 | 0 | 0 | | |
| 33 | SSF2 | 0 | 0 | 0 | 0 | 0 | 0 | 0 | | |
| 34 | SSF3 | 0 | 0 | 0 | 0 | 0 | 0 | 0 | | |
| 35 | SSF4 | 0 | 0 | 0 | 0 | 0 | 0 | 0 | | |
| 36 | PTYP | | | | | | | | | |
| 37 | JL | 0 | 0 | 0 | 0 | 0 | 0 | 0 | | |
| 38 | FHZ | 0 | 0 | 0 | 0 | 0 | 0 | 0 | | |
| 39 | | 0 | 0 | 0 | 0 | 0 | 0 | 0 | | |
| 40 | | 0 | 0 | 0 | 0 | 0 | 0 | 0 | | |
| 41 | LMC2 | 0 | 0 | 0 | 0 | 0 | 0 | 0 | | |
| 42 | OVS2 | 0 | 0 | 0 | 0 | 0 | 0 | 0 | | |
| 43 | | 0 | 0 | 0 | 0 | 0 | 0 | 0 | | |
| 44 | | 0 | 0 | 0 | 0 | 0 | 0 | 0 | | |
| 45 | | 0 | 0 | 0 | 0 | 0 | 0 | 0 | | |
| 46 | | 0 | 0 | 0 | 0 | 0 | 0 | 0 | | |
| 47 | EC1 | 100 | 100 | 100 | 100 | 100 | 100 | 100 | | |
| 48 | | 0 | 0 | 0 | 0 | 0 | 0 | 0 | | |
| 49 | PGN1SP | 15 | 15 | 15 | 15 | 15 | 15 | 15 | | |
| 50 | PGN2SP | 0 | 0 | 0 | 0 | 0 | 0 | 0 | | |
| 51 | DFBT | 0 | 0 | 0 | 0 | 0 | 0 | 0 | | |
| 52 | DFBN | 0 | 0 | 0 | 0 | 0 | 0 | 0 | | |
| 53 | OD3 | 0 | 0 | 0 | 0 | 0 | 0 | 0 | | |
| 54 | ORE | 0 | 0 | 0 | 0 | 0 | 0 | 0 | | |
| 55 | | 0 | 0 | 0 | 0 | 0 | 0 | 0 | | |
| 56 | | 0 | 0 | 0 | 0 | 0 | 0 | 0 | | |
| 57 | SHGC | 0 | 0 | 0 | 0 | 0 | 0 | 0 | | |
| 58 | SHGCSP | 0 | 0 | 0 | 0 | 0 | 0 | 0 | | |
| 59 | | 0 | 0 | 0 | 0 | 0 | 0 | 0 | | |
| 60 | | 0 | 0 | 0 | 0 | 0 | 0 | 0 | | |
| 61 | DA1NO | 0 | 0 | 0 | 0 | 0 | 0 | 0 | | |
| 62 | DA2NO | 0 | 0 | 0 | 0 | 0 | 0 | 0 | | |
| 63 | DA1MPY | 0 | 0 | 0 | 0 | 0 | 0 | 0 | | |
| 64 | DA2MPY | 0 | 0 | 0 | 0 | 0 | 0 | 0 | | |

5. MDS-A/B-V1 Servo Drive

2. 3000rpm motor

| Parameter | Driver | HA053 | HA13 | HA23N | HA33N | HA43N | HA83N | HA103N | HA203N | HA303N | HA703N |
|-----------|--------|-------|------|-------|-------|-------|-------|--------|--------|--------|--------|
| | | 01 | 01 | 03 | 03 | 05 | 10 | 35 | 45 | 70 | 90 |
| sv001 | PC1 | | | | | | | | | | |
| 2 | PC2 | | | | | | | | | | |
| 3 | PGN1 | 33 | 33 | 33 | 33 | 33 | 33 | 33 | 33 | 33 | 33 |
| 4 | PGN2 | 0 | 0 | 0 | 0 | 0 | 0 | 0 | 0 | 0 | 0 |
| 5 | VGN1 | 70 | 70 | 70 | 70 | 150 | 150 | 150 | 150 | 150 | 150 |
| 6 | VGN2 | 0 | 0 | 0 | 0 | 0 | 0 | 0 | 0 | 0 | 0 |
| 7 | VIL | 0 | 0 | 0 | 0 | 0 | 0 | 0 | 0 | 0 | 0 |
| 8 | VIA | 1364 | 1364 | 1364 | 1364 | 1364 | 1364 | 1364 | 1364 | 1364 | 1364 |
| 9 | IQA | 2048 | 2048 | 2048 | 2048 | 2048 | 2048 | 2048 | 2048 | 2048 | 2048 |
| 10 | IDA | 2048 | 2048 | 2048 | 2048 | 2048 | 2048 | 2048 | 2048 | 2048 | 2048 |
| 11 | IQG | 256 | 256 | 256 | 256 | 256 | 256 | 256 | 256 | 256 | 256 |
| 12 | IDG | 256 | 256 | 256 | 256 | 512 | 512 | 512 | 512 | 512 | 512 |
| 13 | ILMT1 | 500 | 500 | 500 | 500 | 500 | 500 | 500 | 500 | 500 | 500 |
| 14 | ILMT2 | 0 | 0 | 0 | 0 | 0 | 0 | 0 | 0 | 0 | 0 |
| 15 | FFC | 0 | 0 | 0 | 0 | 0 | 0 | 0 | 0 | 0 | 0 |
| 16 | LMC1 | 0 | 0 | 0 | 0 | 0 | 0 | 0 | 0 | 0 | 0 |
| 17 | SPEC | | | | | | | | | | |
| 18 | PIT | | | | | | | | | | |
| 19 | RNG1 | | | | | | | | | | |
| 20 | RNG2 | | | | | | | | | | |
| 21 | OLT | 60 | 60 | 60 | 60 | 60 | 60 | 60 | 60 | 60 | 60 |
| 22 | OLL | 150 | 150 | 150 | 150 | 150 | 150 | 150 | 150 | 150 | 150 |
| 23 | OD1 | | | | | | | | | | |
| 24 | INP | 50 | 50 | 50 | 50 | 50 | 50 | 50 | 50 | 50 | 50 |
| 25 | MTYP | XX8C | XX8D | XX6E | XX6F | XX80 | XX81 | XX82 | XX83 | XX84 | XX85 |
| 26 | OD2 | | | | | | | | | | |
| 27 | SSF1 | 4000 | 4000 | 4000 | 4000 | 4000 | 4000 | 4000 | 4000 | 4000 | 4000 |
| 28 | | 0 | 0 | 0 | 0 | 0 | 0 | 0 | 0 | 0 | 0 |
| 29 | VCS | 0 | 0 | 0 | 0 | 0 | 0 | 0 | 0 | 0 | 0 |
| 30 | | 0 | 0 | 0 | 0 | 0 | 0 | 0 | 0 | 0 | 0 |
| 31 | OVS1 | 0 | 0 | 0 | 0 | 0 | 0 | 0 | 0 | 0 | 0 |
| 32 | TOF | 0 | 0 | 0 | 0 | 0 | 0 | 0 | 0 | 0 | 0 |
| 33 | SSF2 | 0 | 0 | 0 | 0 | 0 | 0 | 0 | 0 | 0 | 0 |
| 34 | SSF3 | 0 | 0 | 0 | 0 | 0 | 0 | 0 | 0 | 0 | 0 |
| 35 | SSF4 | 0 | 0 | 0 | 0 | 0 | 0 | 0 | 0 | 0 | 0 |
| 36 | PTYP | | | | | | | | | | |
| 37 | JL | 0 | 0 | 0 | 0 | 0 | 0 | 0 | 0 | 0 | 0 |
| 38 | FHZ | 0 | 0 | 0 | 0 | 0 | 0 | 0 | 0 | 0 | 0 |
| 39 | | 0 | 0 | 0 | 0 | 0 | 0 | 0 | 0 | 0 | 0 |
| 40 | | 0 | 0 | 0 | 0 | 0 | 0 | 0 | 0 | 0 | 0 |
| 41 | LMC2 | 0 | 0 | 0 | 0 | 0 | 0 | 0 | 0 | 0 | 0 |
| 42 | OVS2 | 0 | 0 | 0 | 0 | 0 | 0 | 0 | 0 | 0 | 0 |
| 43 | | 0 | 0 | 0 | 0 | 0 | 0 | 0 | 0 | 0 | 0 |
| 44 | | 0 | 0 | 0 | 0 | 0 | 0 | 0 | 0 | 0 | 0 |
| 45 | | 0 | 0 | 0 | 0 | 0 | 0 | 0 | 0 | 0 | 0 |
| 46 | | 0 | 0 | 0 | 0 | 0 | 0 | 0 | 0 | 0 | 0 |
| 47 | EC1 | 100 | 100 | 100 | 100 | 100 | 100 | 100 | 100 | 100 | 100 |
| 48 | | 0 | 0 | 0 | 0 | 0 | 0 | 0 | 0 | 0 | 0 |
| 49 | PGN1SP | 15 | 15 | 15 | 15 | 15 | 15 | 15 | 15 | 15 | 15 |
| 50 | PGN2SP | 0 | 0 | 0 | 0 | 0 | 0 | 0 | 0 | 0 | 0 |
| 51 | DFBT | 0 | 0 | 0 | 0 | 0 | 0 | 0 | 0 | 0 | 0 |
| 52 | DFBN | 0 | 0 | 0 | 0 | 0 | 0 | 0 | 0 | 0 | 0 |
| 53 | OD3 | 0 | 0 | 0 | 0 | 0 | 0 | 0 | 0 | 0 | 0 |
| 54 | ORE | 0 | 0 | 0 | 0 | 0 | 0 | 0 | 0 | 0 | 0 |
| 55 | | 0 | 0 | 0 | 0 | 0 | 0 | 0 | 0 | 0 | 0 |
| 56 | | 0 | 0 | 0 | 0 | 0 | 0 | 0 | 0 | 0 | 0 |
| 57 | SHGC | 0 | 0 | 0 | 0 | 0 | 0 | 0 | 0 | 0 | 0 |
| 58 | SHGCSP | 0 | 0 | 0 | 0 | 0 | 0 | 0 | 0 | 0 | 0 |
| 59 | | 0 | 0 | 0 | 0 | 0 | 0 | 0 | 0 | 0 | 0 |
| 60 | | 0 | 0 | 0 | 0 | 0 | 0 | 0 | 0 | 0 | 0 |
| 61 | DA1NO | 0 | 0 | 0 | 0 | 0 | 0 | 0 | 0 | 0 | 0 |
| 62 | DA2NO | 0 | 0 | 0 | 0 | 0 | 0 | 0 | 0 | 0 | 0 |
| 63 | DA1MPY | 0 | 0 | 0 | 0 | 0 | 0 | 0 | 0 | 0 | 0 |
| 64 | DA2MPY | 0 | 0 | 0 | 0 | 0 | 0 | 0 | 0 | 0 | 0 |

5. MDS-A/B-V1 Servo Drive

(6) Parameters per servo system

| Parameter | Relative position detection | | | Absolute position detection | | |
|------------------------|---|--|---|--|--|---|
| | Semi-closed loop | Closed loop | | Semi-closed loop | Closed loop | |
| | | Ball screw end detection | Scale detection | | Ball screw end detection | Scale detection |
| sv017 SPEC (HEX) | • bit5-HA23/33N Detector connector position | • bit1 (DUAL FB) • bit4 (polarity) • bit5-HA23/33N Detector connector position | • bit1 (DUAL FB) • bit4 (polarity) • bit5-HA23/33N Detector connector position • bit8 Z-phase type | • bit7=1 | • bit1 (DUAL FB) • bit4 (polarity) • bit5-HA23/33N Detector connector position • bit7=1 | • bit1 (DUAL FB) • bit4 (polarity) • bit5-HA23/33N • bit7=1 • bit8 Z-phase type • bit9-Detector type |
| sv019 RNG1 | 10 (HA053/13) 100 (OHE25K/OSE104) 1000 (OSE105) | 100 (OHE25K/OSE104) 1000 (OSE105) | Ball screw pitch Scale resolution | 100 (OHA25K/OSA104) 1000 (OSA105) | 100 (OHA25) (OSA104) OR 1000 (OSA105) | Ball screw pitch Scale resolution |
| sv020 RNG2 | Same setting as sv019 | 10 (HA053/13) 100 (OHE25K/OSE104) 1000 (OSE105□) | 10 (HA053/13) 100 (OHE25K/OSE104) 1000 (OSE105□) | Same setting as sv019 | 10 (HA053/13) 100 (OHE25K/OSE104) 1000 (OSE105) | 10 (HA053/13) 100 (OHE25K/OSE104) 1000 (OSE105) |
| sv025 MTYP | 33XX (HA053/13) 00XX (OHE25K/OSE104) 22XX (OSE105) | 43XX/63XX 43XX (HA053/13) 40XX/60XX (OSE25K/OSE104) 43XX/62XX (OSE105) | 83XX (HE053/13) 80XX (OHE25K/OSE104) 82XX (OSE105) | 11XX (OHA25K/OSA104) 22XX (OSA105) | 53XX/63XX (HA053/13) 50XX/60XX (OHE25K/OSE104) 52XX/62XX (OSE105) | 93XX/A3XX (HA053/13) 90XX/A0XX (OHE25K/OSE104) 92XX/A2XX (OSE105) |

* The 1 μ m and 0.1 μ m changeover will depend on the NC side parameters. (0.1 μ m cannot be used when using HA053/13.)

5.6 Alarms and warnings

| | |
|--|---------|
| ! | CAUTION |
| When an alarm occurs, remove the cause of the alarm, confirm that an operation signal is not being input, and secure the safety. Then reset the alarm to resume operation. | |

When an alarm occurs in the servo amplifier, the base will be shut off and the motor will coast to a stop. Turn the power OFF with an external sequence. (Refer to 5.8 Main circuit connection.)
When resetting the alarm, remove the cause, and then turn the power ON.

IMPORTANT

When an overcurrent or overload related alarm occurs, if the power is repeated turned OFF and ON to continue operation without removing the cause of the alarm, the temperature will rise and lead to element damage.

The amplifier state is displayed on the servo amplifier display with a code and the data is transferred to the NC. The alarm is also displayed on the NC screen when an alarm occurs. (The alarm No. on the NC screen may differ from the servo amplifier alarm No. Refer to the NC Instruction Manual for details.)

Refer to "MDS Series Maintenance Manual" BNP-B2046 for details on troubleshooting.

| # | Status | Description |
|----|------------|---|
| AA | INITIALIZE | Waiting for NC power start up (NC power ON → OFF). |
| Ab | INITIALIZE | Waiting for NC power start up |
| AC | INITIALIZE | During parameter transfer request |
| Ad | INITIALIZE | Waiting for parameter conversion request |
| AE | INITIALIZE | Waiting for main servo IT start |
| b* | READY OFF | Ready OFF |
| C* | READY ON | Servo OFF |
| d* | SERVO ON | Servo ON |
| 9* | WARNING | Warning |
| E* | WARNING | Warning (However, E6, E7 are status displays other than alarms or warnings.) |
| ** | ALARM | Alarm |

* : Axis number * : Warning number (See next page.) ** : Alarm number (See next page.)

Example of the display (when relevant amplifier is set to No. 1 axis)

(1) During servo ON

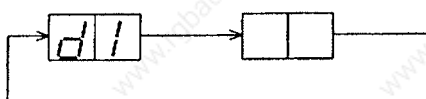

(2) During alarm (display flickers)



5. MDS-A/B-V1 Servo Drive

<Servo alarms>

| Dis- play | Abbr. | Name | Meaning | Re- lease | Class | Alarm/warning check period | | | |
|--------------|-------|---|---|--------------|-------|-------------------------------|----|----|----|
| | | | | | | f1 | f2 | f3 | f4 |
| 11 | ASE | Axis selection error | When using the 2-axis integral drive unit, the axis setting rotary switch setting is illegal. | AR | C | ○ | - | - | - |
| 12 | ME | Memory error | The memory IC (SRAM or FLROM) check sum was illegal. | AR | C | ○ | - | - | - |
| 13 | SWE | Software processing error | The software data processing was not completed within the normal time. Includes peripheral G/A errors. | PR | C | - | ○ | ○ | ○ |
| 16 | RD1 | Pole position detection error | The differential input of the U, V, or W phase of the pole position detection signal of the OHE type detector were both "H" or "L". | PR | A | - | ○ | ○ | - |
| 17 | ADE | AD converter error | The AD converter for current detection did not function correctly during initialization. | PR | A | - | ○ | - | - |
| 18 | WAT | Initial communication error | The absolute position or magnetic pole position data was not correctly communicated in the OHA type detector or serial pulse encoder. | PR | A | - | ○ | - | - |
| 1A | STE1 | Serial detector communication error (SUB) | The initial communication with the serial pulse encoder installed on the ball screw end was not possible. | PR | A | - | ○ | - | - |
| 1B | Scpu | CPU error (SUB) | An error was detected in the data stored in the EEROM of the serial pulse encoder installed on the ball screw end. (Alarm output by the detector.) | PR | A | - | ○ | ○ | ○ |
| 1C | Sled | LED error (SUB) | Deterioration of the LEDs in the serial pulse encoder installed on the ball screw end was detected. (Alarm output by the detector.) | PR | A | - | ○ | ○ | ○ |
| 1D | Sdat | Data error (SUB) | An error was detected in the per rotation position data of the serial pulse encoder installed on the ball screw end. (Alarm output by the detector.) | PR | A | - | ○ | ○ | ○ |
| 1E | SOHE | Serial detector thermal error (SUB) | The thermal protector built in the detector operated in the serial pulse encoder installed on the ball screw end. (Alarm output by the detector.) | PR | A | - | ○ | ○ | ○ |
| 1F | Stre | Communication error (SUB) | Communication with the detector in the serial pulse encoder installed on the ball screw end was cut off. | PR | A | - | ○ | ○ | - |
| 20 | NS1 | No signal detected 1 | The differential input of the A, B or Z-phase signal from the motor end installation detector were both "H" or "L". (Software detection in B Series.) | PR | A | - | ○ | ○ | - |
| 21 | NS2 | No signal detected 2 | The differential input of the A, B or Z-phase signal from the machine end installation detector were both "H" or "L". (Software detection in B Series.) | PR | A | - | ○ | ○ | - |
| 25 | ABSE | Absolute position lost | The absolute position data in the absolute value detector was lost. | AR | A | - | ○ | - | - |
| 26 | NAE | Not used axis error | When using the 2-axis integrated drive unit, the axis setting rotary switch was set to "F", and a power module error occurred in the axis not being controlled. | PR | C | - | ○ | ○ | ○ |
| 27 | SCCPU | Absolute position detection scale CPU error | An error was detected in the CPU of the absolute position linear scale. (Alarm output by the detector.) | PR | A | - | ○ | ○ | ○ |
| 28 | SOSP | Absolute position overspeed | The scale moved at more than 45mm/sec during initialization with the absolute value linear scale. (Alarm output by the linear scale.) | PR | A | - | ○ | - | - |
| 29 | SABS | Absolute position detection circuit error | A hardware error was detected in the absolute position detection circuit of the absolute position linear scale. (Alarm output by the linear scale.) | PR | A | - | ○ | ○ | ○ |
| 2A | SINC | Relative position detection circuit error | A hardware error was detected in the relative position detection circuit of the absolute position linear scale. (Alarm output by the linear scale.) | PR | A | - | ○ | ○ | ○ |
| 2B | SCPU | CPU error | A CPU error was detected in the serial pulse encoder installed on the motor end. (Alarm output by the detector.) | PR | A | - | ○ | ○ | ○ |
| 2C | SLED | LED error | Deterioration of the LEDs in the serial pulse encoder installed on the motor end was detected. (Alarm output by the detector.) | PR | A | - | ○ | ○ | ○ |
| 2D | SDAT | Data error | An error was detected in the per rotation position data of the serial pulse encoder installed on the motor end. (Alarm output by the detector.) | PR | A | - | ○ | ○ | ○ |
| 2F | STRE | Communication error | Communication with the OHA type detector or serial pulse encoder installed on the motor end and the detector was cut off. | PR | A | - | ○ | ○ | ○ |
| 31 | OS | Overspeed | The motor speed reached 1.2 times the rated speed. | PR | A | - | ○ | ○ | - |
| 32 | PMOC | Power module overcurrent | An overcurrent was detected in the IPM used in the servo drive's main circuit. | PR | A | - | ○ | ○ | ○ |
| 34 | DP | CRC error | A CRC error occurred in the communication data from the NC. | PR | C | - | ○ | ○ | ○ |
| 35 | DE | Data error | The movement command data from the NC is abnormally large. | PR | A | - | ○ | ○ | - |
| 36 | TE | Transmission error | The cycle data transmission from the NC was terminated. | PR | C | - | ○ | ○ | - |

5. MDS-A/B-V1 Servo Drive

| Dis-play | Abbr. | Name | Meaning | Re-lease | Class | Alarm/warning check period | | | |
|---------------|-------|------------------------|---|----------|-------|----------------------------|----|----|----|
| | | | | | | f1 | f2 | f3 | f4 |
| 37 | PE | Parameter error | An illegal servo parameter was sent from the NC during initialization of the servo drive. | PR | A | - | ○ | - | ○ |
| 38 | TP1 | Protocol error 1 | There was an error in the communication protocol with the NC. (Frame error) | PR | C | - | ○ | ○ | ○ |
| 39 | TP2 | Protocol error 2 | There was an error in the communication protocol with the NC. (Information error) | PR | A | - | ○ | ○ | ○ |
| 3A | OC | Overcurrent | An excessive current flowed to the motor. | PR | A | - | ○ | ○ | ○ |
| 3B | PMOH | Power module overheat | Overheating of the IPM used in the servo driver's main circuit was detected. | PR | A | - | ○ | ○ | ○ |
| 42 | FE1 | Feedback error 1 | ① A skip of the detector feedback signal pulse occurred in the OHE type or OHA type detector used in the semi-closed loop system and ball screw end closed loop system. ② A skip of the detector feedback pulse in the low-speed serial type absolute position linear scale. | PR | A | - | ○ | ○ | - |
| 43 | FE2 | Feedback error 2 | A deviation occurred in the feedback amount from the motor end detector and machine end detector in the closed loop system. | PR | A | - | ○ | ○ | - |
| 46 | OHM | Motor overheat | The motor or detector thermal protector operated. | NR | A | - | ○ | ○ | - |
| 50 | OL1 | Overload 1 | The motor current operated in the range set with the overload detection level (parameter OLL) and overload time constant (parameter OLT). | NR | A | - | ○ | ○ | ○ |
| 51 | OL2 | Overload 2 | A current command with a maximum output current exceeding 95% continued for 1 second or more. | NR | A | - | - | ○ | - |
| 52 | OD1 | Excessive error 1 | The actual position to the command exceeded the excessive error width 1 (parameter OD1) when the servo was turned ON. | NR | A | - | - | ○ | - |
| 53 | OD2 | Excessive error 2 | The actual position to the command exceeded the excessive error width 2 (parameter OD2) when the servo was turned OFF. | NR | A | - | ○ | - | - |
| 54 | OD3 | Excessive error 3 | The motor current did not flow when the excessive error 1 alarm was detected. (Added with the B Series.) | NR | A | - | - | ○ | - |
| 58 | CLE0 | Collision detection 0 | A collision detection type 1 error was detected during the G0 modal (rapid traverse). | NR | A | - | - | ○ | - |
| 59 | CLE1 | Collision detection 1 | A collision detection type 1 error was detected during the G1 modal (cutting feed). | NR | A | - | - | ○ | - |
| 5A | CLT2 | Collision detection 2 | A collision detection type 2 error was detected. | NR | A | - | - | ○ | - |
| 60 ~ 7F | | | An error occurred in the power supply unit. (Refer to the power supply section for details) | | | | | | |
| 82 | NSP | Power supply no signal | Breakage or incorrect connection of the cable connected to the power supply was detected. (A Series only) | PR | C | - | ○ | ○ | ○ |
| 88 | WD | Watch dog | The servo amplifier software process was not executed within the designated time. | AR | C | ○ | ○ | ○ | ○ |

<Servo warning>

| | | | | | | | | | |
|----|-----|--|---|----|---|---|---|---|---|
| 90 | WST | Low-speed serial initial communication error | Initial communication with the low-speed serial type absolute position linear scale was not possible. | PR | A | - | ○ | - | - |
| 91 | WAS | Detector communication error | The absolute position serial data was not correctly communicated from the OHA type detector and low-speed serial type absolute position linear scale. | - | A | - | ○ | ○ | - |
| 92 | WAF | Detector serial format error | The format of the serial data from the OHA type detector and low-speed serial type absolute position linear scale was incorrect. | - | A | - | ○ | ○ | - |
| 93 | WAM | Absolute position fluctuation | The absolute value counter cannot be set as the absolute position data fluctuated when the NC power was turned on. | PR | A | - | ○ | ○ | - |
| 96 | MPE | MP scale feedback error | In the MP scale absolute detection system, an excessive deviation in the motor end installation detector and MP scale feedback amount was detected. | - | A | - | ○ | ○ | ○ |
| 97 | MPO | MP scale offset error | In the MP scale absolute position detection system, an error was detected in the offset data read when the NC power was turned ON. | PR | A | - | ○ | - | - |
| 9E | WAN | High-speed serial multi-rotation counter error | An error was detected in the multi-rotation counter in the serial pulse encoder installed on the motor end or ball screw end. | - | A | - | ○ | ○ | ○ |
| 9F | WAB | Battery voltage drop | The voltage of the battery supplied to the absolute value detector dropped. | - | C | - | ○ | ○ | ○ |

5. MDS-A/B-V1 Servo Drive

| Dis-play | Abbr. | Name | Meaning | Re-lease | Class | Alarm/warning check period | | | |
|----------|-------|-----------------------------------|---|----------|-------|----------------------------|----|----|----|
| | | | | | | f1 | f2 | f3 | f4 |
| E1 | WOL | Overload warning | An 80% level of the overload 1 alarm was detected. (If operation is continued, the overload 1 alarm may occur.) | - | A | - | ○ | ○ | ○ |
| E3 | WAC | Absolute position counter warning | The absolute position counter value is illegal. The absolute position must be initialized. | - | A | - | ○ | ○ | - |
| E4 | WPE | Parameter error warning | A parameter exceeding the setting range was set. The illegal parameter will be ignored and the previously set value will be held. | - | A | - | ○ | ○ | - |

<Status displays other than alarms and warnings>

| | | | | | | | | | |
|------------|-----|-----------------------|---|---|---|---|---|---|---|
| E6 | AXE | Removing control axis | The axis removal command is input from the NC. | - | A | - | ○ | ○ | ○ |
| E7 | NCE | NC emergency stop | The emergency stop command is input from the NC. | - | C | - | ○ | ○ | ○ |
| E8 ~ EB | | | A warning was generated with the power supply unit. (Refer to the power supply unit item for details.) | / | / | / | / | / | / |

[Release]

AR : The alarm is released by turning the servo driver power off and on.

PR : The alarm is released by turning the NC power off and on.

NR : The alarm is released with the NC reset key. (However, overload alarm "50" cannot be released until the load is lowered passed the reset level (30% of the current value on the MONITOR screen).)

- : Automatically restored when the warning state is eliminated.

[Class]

C : Detects both axes even during the 2-axis integrated amplifier.

A : Detects each axis independently.

[Alarm/warning check period]

f1 : When servo driver power is turned on.

f2 : When NC power is turned on (emergency stop on)

f3 : Constantly during operation (servo ON)

f4 : During axis removal (ready ON, servo OFF)

(Note: *1; Warning "93" may occur after axis removal while installing the axis again.)

5. MDS-A/B-V1 Servo Drive

5.7 Explanation of connector and terminal block

| | | Name | Application | Remarks |
|----------------|-----|--------------------------------|---|--|
| Connector | | CN1A | For connection with NC and high-order axis | For combination of V1-110/150 dynamic brake contact output |
| | | CN1B | For connection with battery unit and low-order axis | |
| | | CN9 | For maintenance (not used normally) | |
| | | CN4 | For connection with power supply | |
| | | CN2 | For connection with motor end detector | |
| | | CN3 | For connection with machine end detector | |
| | | CN20 | External brake output contact point | |
| Terminal block | TE2 | L+ | Converter voltage input (+) | |
| | | L- | Converter voltage input (-) | |
| | TE3 | L11 | AC200V single-phase input | |
| | | L21 | | |
| | TE1 | U | U-phase output for motor drive | |
| | | V | V-phase output for motor drive | |
| W | | W-phase output for motor drive | | |
| ⊕ | | Grounding | | |

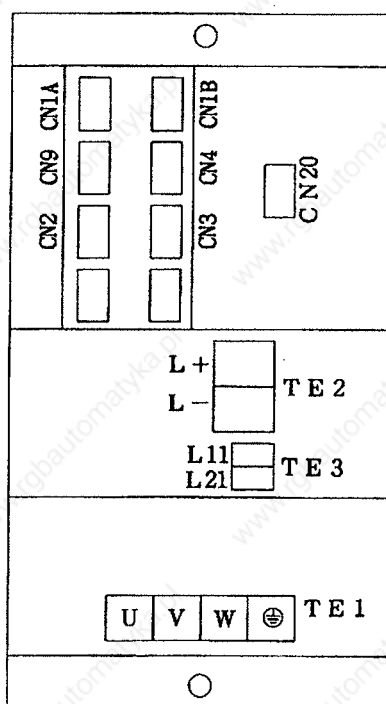

MDS-A/B-V1

5. MDS-A/B-V1 Servo Drive

5.8 Main circuit and brake connection



WARNING

Always ground the servo drive unit and servomotor with Class 3 or higher grounding.



CAUTION

1. Correctly connect the power phases (U, V, W) of the servo drive unit and servomotor. Failure to do so could cause the servomotor to malfunction.
2. Do not apply a voltage other than that specified to each terminal. Failure to observe this could lead to ruptures or trouble.

5.8.1 Main circuit

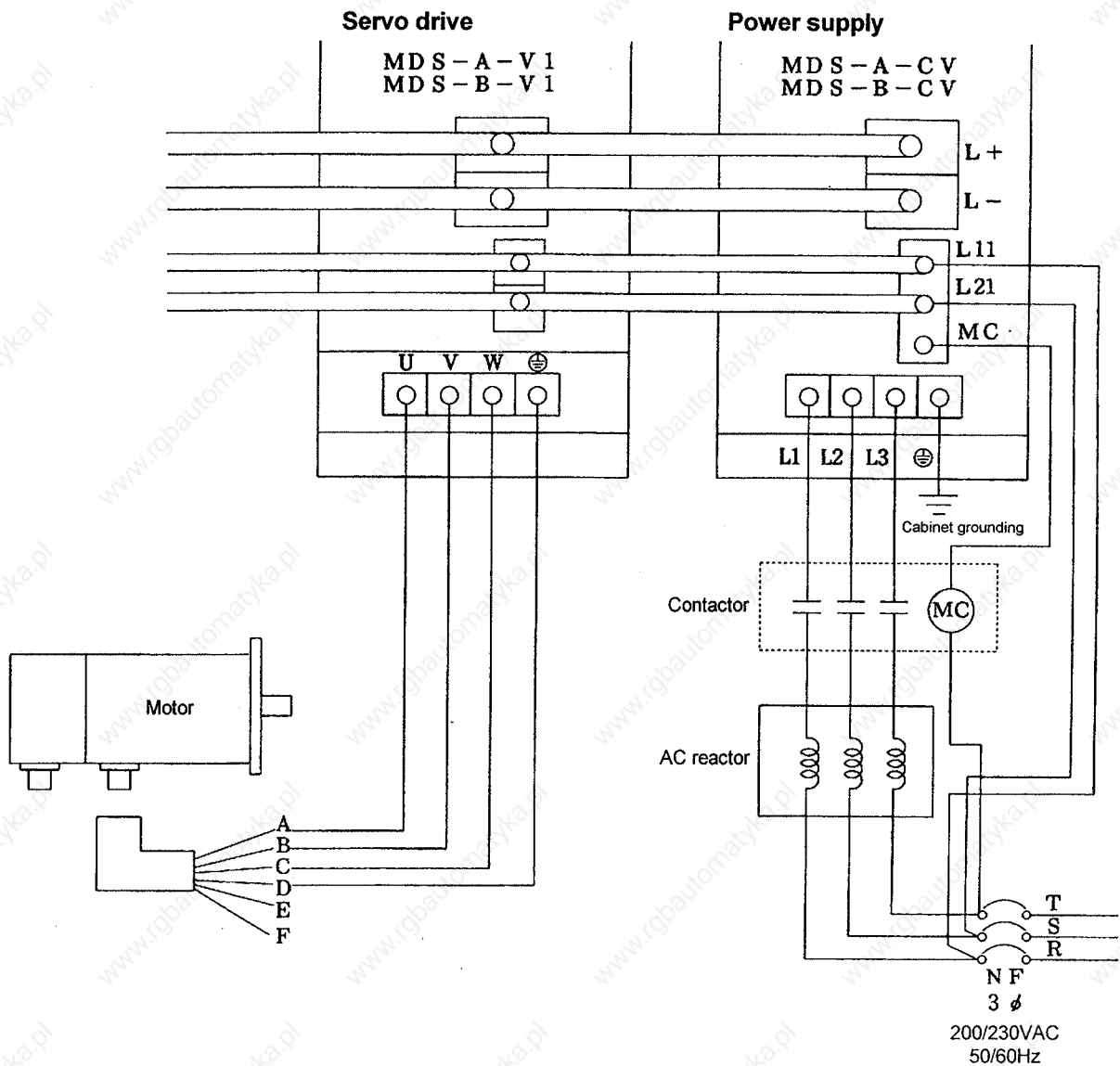

5. MDS-A/B-V1 Servo Drive

- * Starting from production in April 1995, a grounding bar is enclosed with each unit when shipped. Connect the grounding wire as shown, and make sure that the grounding wires are not tightened together.

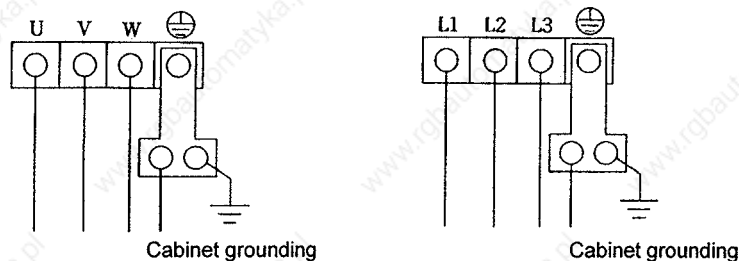

Precautions for connections

- (1) The wires and crimp terminals will differ according to the capacity.
(Refer to section 8.3 in the Chapter I Servo/Spindle system configuration.)
- (2) Always ground (⊕) the power supply.
- (3) The phase order of the power supply terminals L1, L2, L3 is random.
- (4) Precautions for connecting servo drive terminals U, V, W
 - a. Always observe the phase order for the servo amplifier terminals U, V, W and motor side pins A, B, C. The motor may vibrate and rotate suddenly if the phase order is mistaken. The phases cannot be reversed for reverse rotation.
 - b. Never perform connections that might apply the power on the servo drive output terminals U, V, W. Never ground the servo drive output terminals U, V, W or connect so that grounding may occur as this may destroy the servo drive.
- (5) The Cannon plug used will differ according to the motor. Refer to section 2.8 (3) for the connection drawing of the brake exciter circuit for motor with electromagnetic brake. Refer to section 2.7 (2) for the terminal box type motor.
- (6) Refer to the Chapter I Servo/Spindle system configuration for the selection of the contactor, AC reactor and non-fuse breaker connected to the power supply.
- (7) Make sure that the specified power is supplied to the servo drive power terminals (L1, L2, L3). If the power does not have the specified voltage, use a transformer.
- (8) Do not directly apply commercial power on the motor.
- (9) Check once again that the wires are connected correctly as indicated in the wiring diagram.

5. MDS-A/B-V1 Servo Drive

5.8.2 Brake

Contact connection terminals for brake (EM1, EM2)

A contact for the brake has been newly installed on the MDS-A/B-V1 servo amplifier. This contact can be used for exciting the motor with brake. Connect the electromagnetic brake cable to connector CN20.

Contact for brake specifications

| Type | Specifications |
|--|-----------------------|
| Rated control capacity (resistance load) | 8A 250V AC/ 5A 30V DC |
| Contact max. tolerable electricity (resistance load) | 2000VA 150WA |
| Contact max. tolerable voltage/current | 380V AC /8A |

Examples of connection with contact for brake

(1) For AC OFF

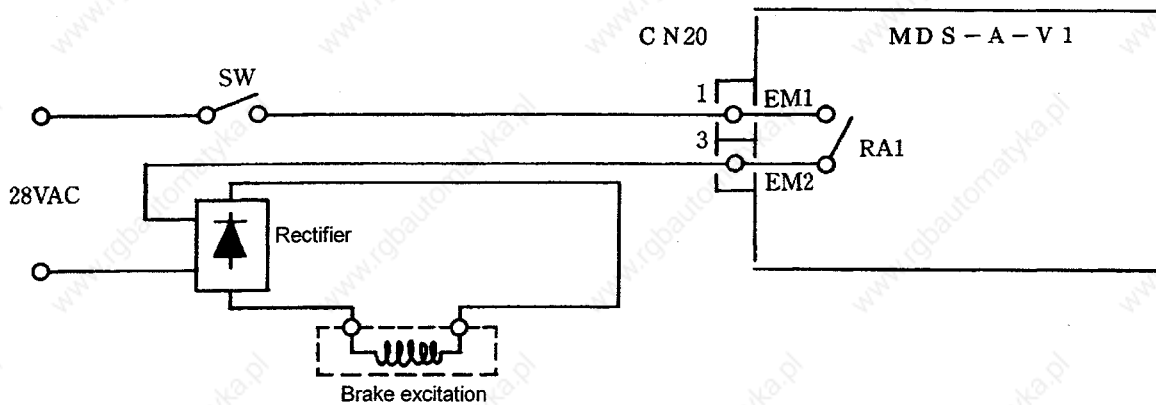

(2) For DC OFF

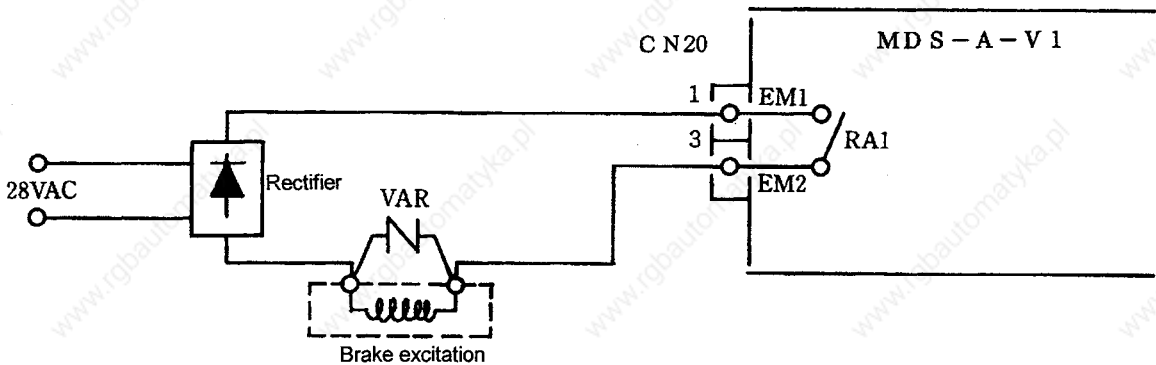

Refer to section 2.9 for the electromagnetic brake specifications and application.

5.9 Wiring system diagrams for systems

The following points differ with the conventional servo system.

- a) The detector feedback interfaces are all the same. Thus, a feedback interface PCB does not need to be prepared for each specification.
- b) Both 1 micron and submicrons can be handled with the same detector. Thus, the same cable can be used.
- c) The power cable (L1, L2, L3) needs to be wired to only one position (power supply unit).

5. MDS-A/B-V1 Servo Amplifier

(1) Servo system configuration table

| System | Configuration | Performance | Servo drive unit | | Detector | | F/B cable connecting connector | | |
|-----------------------------|----------------------------|---|---|--------------------------|--|--|--------------------------------|-------------|---|
| | | | No. of axes | Model | Motor end detector | Machine end detector | Motor end | Machine end | |
| Relative position detection | Semi-closed loop | <ul style="list-style-type: none"> • Max. tracking performance: 5MPPS • Min. resolution: 0.0036° • Max. speed: 3000r/min | 1 | MDS-A-V1-□ MDS-B-V1-□ | OSE104 OHE25K-6 or more OSE104S HA23 OHE25K-85 HA33 | — | CN2 | — | |
| | | | 2 | MDS-A-V2-□ MDS-B-V2-□ | Low inertia motor OHE25K-108 Built-in encoder HA053 HA13 | — | — | — | |
| | Closed loop | <ul style="list-style-type: none"> • Max. tracking performance: 5MPPS • Min. resolution: 0.0036° • Max. speed: 3000r/min | 1 | MDS-A-V1-□ MDS-B-V1-□ | OSE104 OHE25K-6 or more OSE104S HA23 OHE25K-85 HA33 | OSE104ET OHE25K-ET | CN2 | CN3 | |
| | | | 2 | MDS-A-V2-□ MDS-B-V2-□ | Low inertia motor OHE25K-108 Built-in encoder HA053 HA13 | Various scales of pulse F/B outputs of 1μ and 0.5μ specifications can be connected. Example: MP scale (Mitsubishi Heavy Industries) | CN2 | CN3 | |
| | Absolute position detector | Semi-closed loop | <ul style="list-style-type: none"> • Max. tracking performance: 5MPPS • Min. resolution: 0.0036° • Max. speed: 3000r/min | 1 | MDS-A-V1-□ MDS-B-V1-□ | OSA104 OHA25K-4 or more | — | CN2 | — |
| | | | | 2 | MDS-A-V2-□ MDS-B-V2-□ | OSA104S OHA25K-108 Low inertia motor OHE25K-108 Built-in encoder HA053 HA13 | — | — | — |
| Closed loop | | <ul style="list-style-type: none"> • Max. tracking performance: 5MPPS • Min. resolution: 0.0036° • Max. speed: 3000r/min | 1 | MDS-A-V1-□ MDS-B-V1-□ | OSE104 OHE25K-6 or more OSE104S HA23 OHE25K-85 HA33 | OSA104ET OHA25K-ET | CN2 | CN3 | |
| | | | 2 | MDS-A-V2-□ MDS-B-V2-□ | Low inertia motor OHE25K-108 Built-in encoder HA053 HA13 | Absolute value linear scale AT-41 (Mitsutoyo) | CN2 | CN3 | |

5. MDS-A/B-V1 Servo Drive

(2) Cable system drawings for each specification

Semi-closed loop position detection system

1. 1-axis servo amplifier

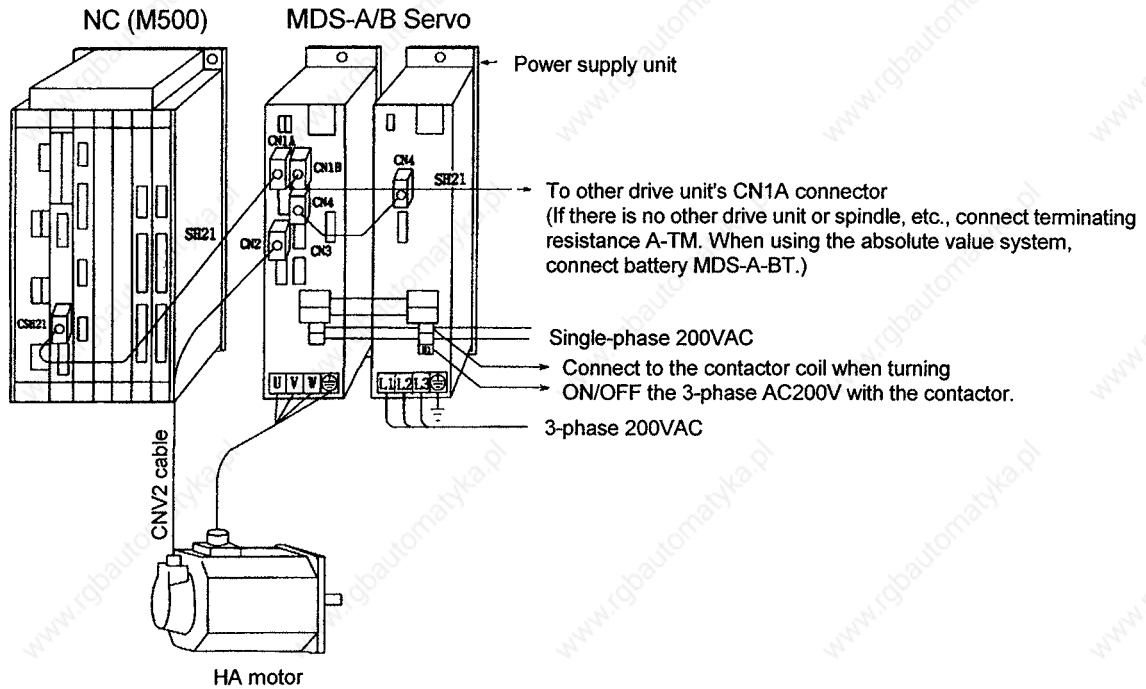

2. 2-axis servo amplifier

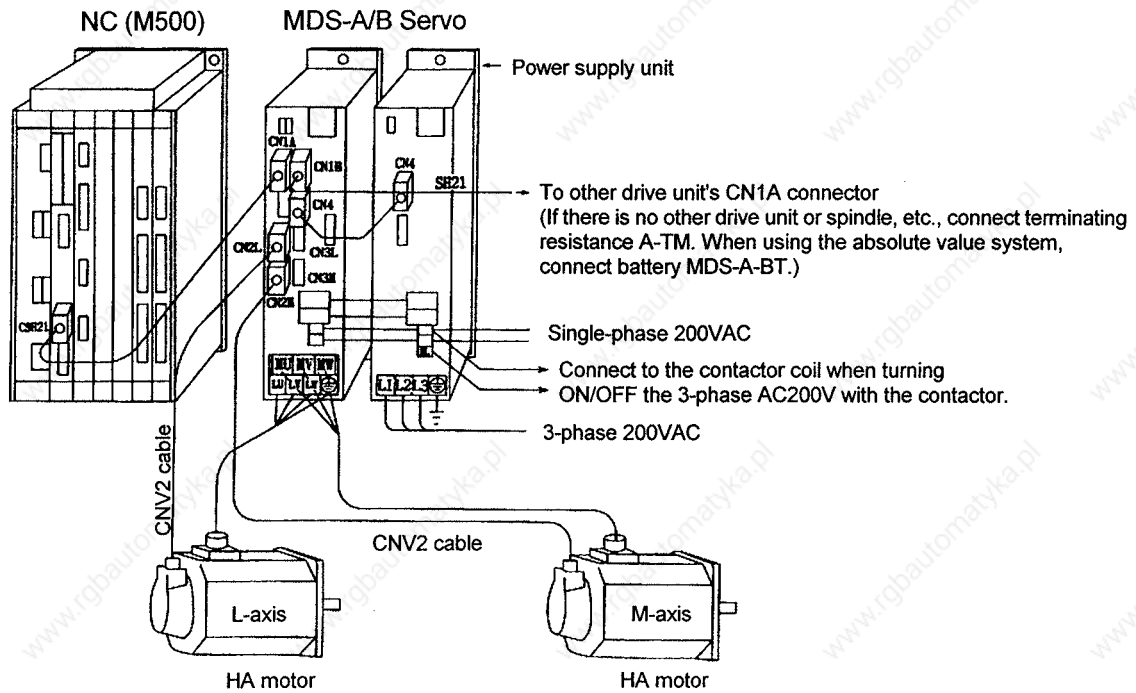

5. MDS-A/B-V1 Servo Drive

Ball screw end position detection system

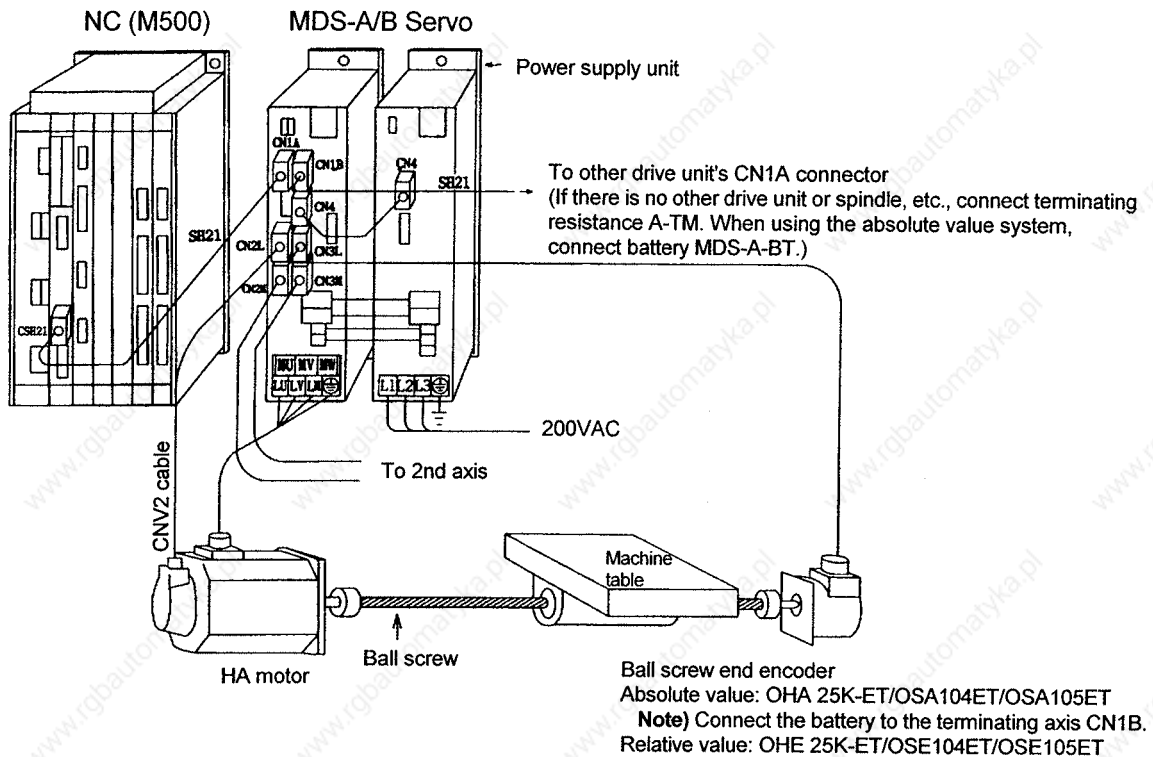

Machine end detection system

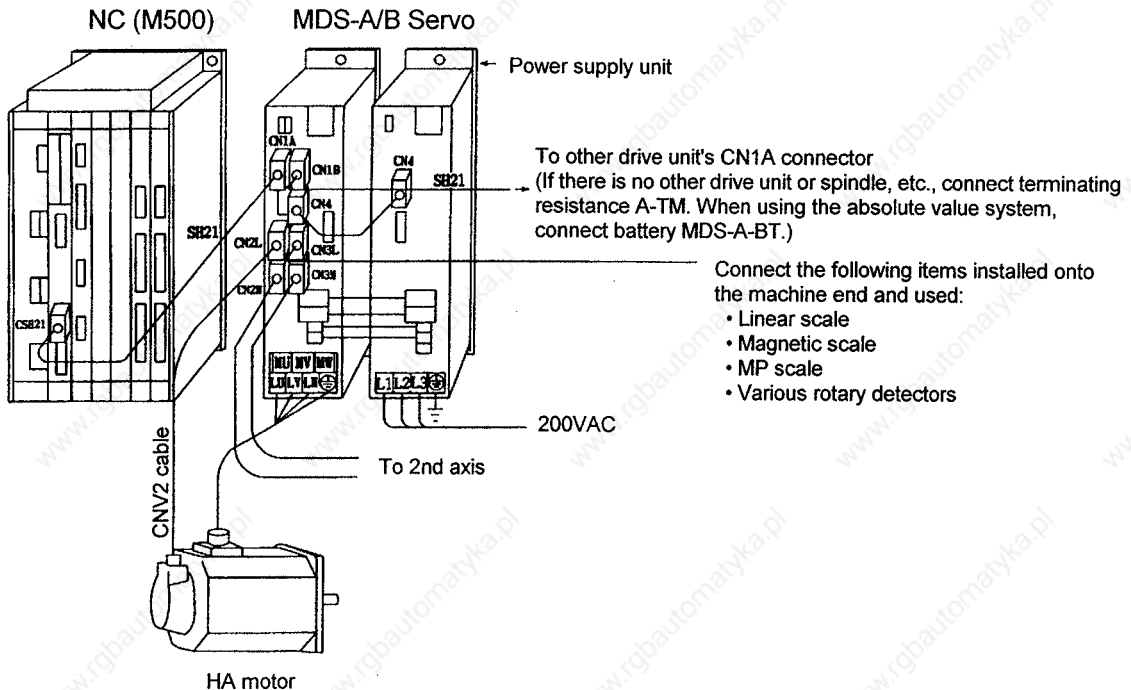

5. MDS-A/B-V1 Servo Drive

Absolute position linear scale detection system

Features

1. An interface for the scale is mounted as a standard, so the scale can be connected directly.
2. A battery is not required for the absolute value detection.
3. Both the absolute value and relative value signals are detected, so a high precision absolute position detection is possible and high-speed and high response control is possible.

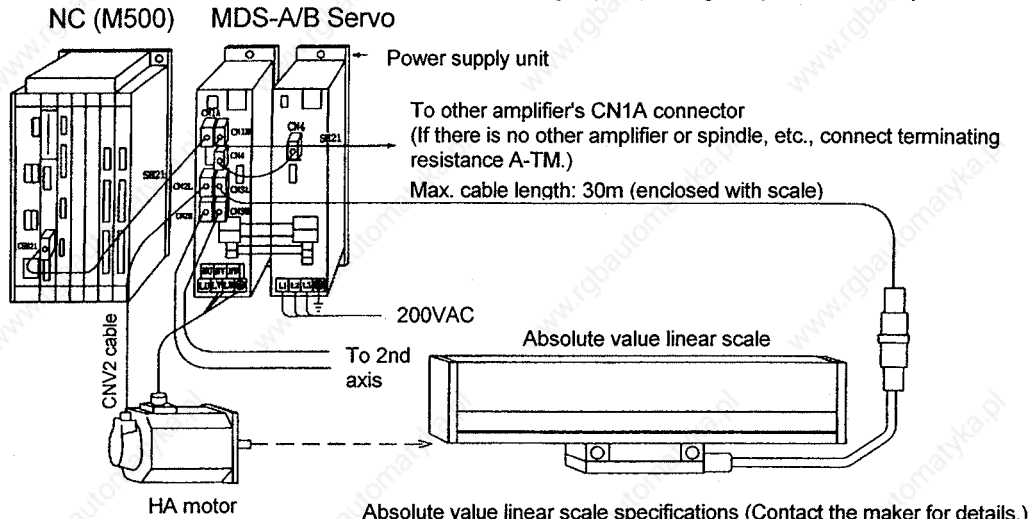

Absolute value linear scale specifications (Contact the maker for details.)

1. Maker : Mitsutoyo Model: AT41
2. Resolution : 1 μ m
3. Precision : (3 + 3L/1000) μ m
4. Effective length L : Max. 1500mm
5. Working temperature range: 0 ~ 45°C
6. Working humidity range : 20 ~ 80%
7. Sealing properties : 1P53

5.10 D/A output function

5.10.1 Outline

The D/A output function is mounted in the standard system of the MDS Series. Thus, the PCB for analog monitoring required in the conventional digital servo system is not longer required. The D/A output level differs between the MDS-A-VX Series and MDS-B-VX Series. Refer to the 5.10.2 Hardware specifications and 5.10.5 Output magnification settings.

5.10.2 Hardware specifications

| MDS-A-VX | | MDS-B-VS |
|------------------|---|--------------|
| • 8-bit \pm 5V | | 8-bit 0 ~ 5V |
| • 2 channels | | |
| • Output pins | CH1 : CN9-9 pin CH2 : CN9-19 pin GND: CN9-1 pin | |

5. MDS-A/B-V1 Servo Drive

5.10.3 Parameters

The data No. and output magnification for each channel is set with the following parameters.

| Name | Description |
|-------|------------------------------------|
| SV061 | D/A channel 1 data No. |
| SV062 | D/A channel 2 data No. |
| SV063 | D/A channel 1 output magnification |
| SV064 | D/A channel 2 output magnification |

5.10.4 Output data No.

The data to be output to SV061 and SV062 is set. When -1 is set for the output data No., D/A output will not take place at that channel.

| No. | CH1 | | CH2 | |
|-----|----------------------------------|--|----------------------------------|--|
| | Output data | Unit | Output data | Unit |
| - 1 | D/A output not selected | | D/A output not selected | |
| 0 | Speed feedback | r/min | Current command | Stall rated current % |
| 1 | Current command | Stall rated current % | Current command | Stall rated current % |
| 2 | Current command | Stall rated current % | Current command | Stall rated current % |
| 3 | Current feedback | Stall rated current % | Current feedback | Stall rated current % |
| 4 | Speed feedback low-order | r/min | Speed feedback low-order | r/min |
| 5 | Speed feedback high-order | r/min | Speed feedback high-order | r/min |
| 6 | Position droop low-order | Interpolation unit | Position droop low-order | Interpolation unit |
| 7 | Position droop high-order | Interpolation unit | Position droop high-order | Interpolation unit |
| 8 | Position F Δ T low-order | Interpolation unit/ NC communication cycle | Position F Δ T low-order | Interpolation unit/ NC communication cycle |
| 9 | Position F Δ T high-order | Interpolation unit/ NC communication cycle | Position F Δ T high-order | Interpolation unit/ NC communication cycle |
| 10 | Position command low-order | Interpolation unit | Position command low-order | Interpolation unit |
| 11 | Position command high-order | Interpolation unit | Position command high-order | Interpolation unit |
| 12 | Feedback position low-order | Interpolation unit | Feedback position low-order | Interpolation unit |
| 13 | Feedback position high-order | Interpolation unit | Feedback position high-order | Interpolation unit |
| 125 | Test output saw-tooth wave | $\pm 5V$ | Test output saw-tooth wave | $\pm 5V$ |
| 126 | Test output rectangular wave | $\pm 5V$ | Test output rectangular wave | $\pm 5V$ |
| 127 | Test output 0V | $\pm 5V$ | Test output 0V | $\pm 5V$ |

5.10.5 Setting of output magnification

The output magnification is set in SV063 and SV064.

The D/A converter input is 7-bit excluding the symbol bit, so determine the magnification parameter A so that (input data) x A/256 is 127 or less. The output polarity will be reversed if a negative value is set.

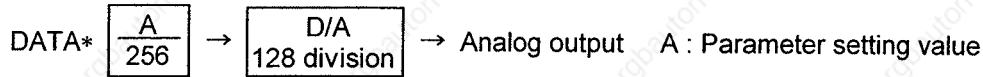

$$\text{Analog output voltage (V)} = \left\{ \text{DATA} * \frac{A}{256} * \frac{\text{Output max. voltage}}{128} \right\} + \text{Offset voltage}$$

| | D/A output max. voltage | Offset voltage |
|-------|-------------------------|----------------|
| MDS-A | 5.0 (V) | 0 (V) |
| MDS-B | 2.5 (V) | 2.5 (V) |

(Example) Speed feedback (MDS-A Series)

The output value is r/min. Thus, 2000 will be output at a speed of 2000r/min. If parameter is set to 256 (magnification 1), the D/A output voltage will be $2000/128 * 5 \text{ (V)} = 78.13$, and the D/A output voltage 5V will be exceeded. Thus, in this case, the parameter must be set to 16; in other words, magnification 1/16, and the D/A output voltage will be $2000 * 5/(128 * 16) = 4.88\text{V}$.

(Example) Speed feedback (MDS-B Series)

The output value is r/min. Thus, 2000 will be output at a speed of 2000r/min. If parameter is set to 256 (magnification 1), the D/A output voltage will be $2000/128 * 2.5 \text{ (V)} = 39.06$, and the D/A output voltage 2.5V will be exceeded. Thus, in this case, the parameter must be set to 16; in other words, magnification 1/16, and the D/A output voltage will be $2000 * 2.5/(128 * 16) = 2.44\text{V}$.

Analog output voltage

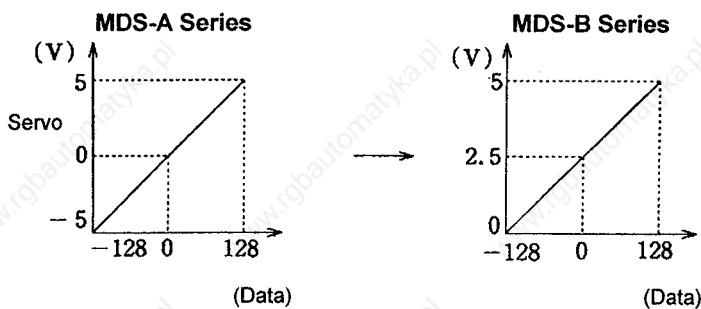

5.10.6 Others

The D/A output channel has two channels even in the 2-axis servo drive. Thus, set the output No. for the axis not to be observed in the 2-axis servo drive to -1. If the D/A output of each channel is set for both axes, the L-axis data will be output. If -1 is set in the D/A output No. for both axes, the output will be 0V.

6. MDS-A/B-V2 Servo Drive

6.1 Model configuration

2-axis servo drive unit model designation

MDS - A - V2 -

MDS - B - V2 -

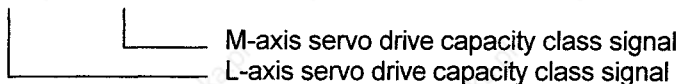

The power class symbols are the same as for the MDS-A/B-V1 servo drive.

| Symbol | Capacity kW | Applicable motor | | | |
|--------|-------------|--------------------|--------------------|------------------------------|------------------------------|
| | | Standard 2000r/min | Standard 3000r/min | Low inertia L-type 2000r/min | Low inertia L-type 3000r/min |
| 01 | 0.1 | | HA053 HA13 | | |
| 03 | 0.3 | | HA23N HA33N | | |
| 05 | 0.5 | HA40N | HA43N | HA50NL | |
| 10 | 1.0 | HA80N | HA83N | HA100NL | HA53NL |
| 20 | 2.0 | HA100N | | HA150NL HA200NL | HA103NL HA153NL |
| 35 | 3.5 | HA200N | HA103N | HA300NL | HA203NL |
| 45 | 4.5 | HA300N | HA203N | HA500NL | HA303NL |

6. MDS-A/B-V2 Servo Drive

6.2 Servo drive unit specifications

| | Unit | 2-axis amplifier model name | | | | | | | | | |
|---|-------------------------|---|----------------|----------------|----------------|----------------------------|----------------|----------------------------|----------------|----------------------------|--------------------------------------|
| | | MDS-A/B- | | | | | | | | | |
| | | V2-0101 | V2-0301 | | V2-0303 | V2-0501 | | V2-0503 | | V2-0505 | V2-1005 |
| Applicable motor | | L/M | L | M | L/M | L | M | L | M | L/M | L |
| | | HA053 | HA23N | HA053 | HA23N | HA40N | HA053 | HA40N | HA23N | HA40N | HA80N |
| | | HA13 | HA33N | HA13 | HA33N | HA43N | HA13 | HA43N | HA33N | HA43N | HA83N |
| | | | | | HA50NL | | HA50NL | | HA50NL | HA100L | HA53NL |
| Output voltage | V | 155V | | | | | | | | | |
| Rated output current | A | 0.95 | 2.9 | 0.95 | 2.9 | 3.4 | 0.95 | 3.4 | 2.9 | 3.4 | 6.8 |
| Continuous output current | A | 1.4 | 3.0 | 1.4 | 3.0 | 5.0 | 1.4 | 5.0 | 3.0 | 5.0 | 8.8 |
| Maximum output current | A | 3.9 | 8.1 | 3.9 | 8.1 | 17 | 3.9 | 17 | 8.1 | 17 | 28 |
| Maximum output torque (During combination with motor) Refer to 5.2VI Specifications for applicable motor. | N·m | 0.686 1.372 | 2.746 5.590 | 0.686 1.373 | 2.746 5.590 | 14.220 10.200 13.043 | 0.686 1.373 | 14.220 10.200 13.043 | 2.746 5.590 | 14.220 10.200 13.043 | 25.497 19.221 20.888 14.220 |
| Control system | | Sine wave PWM system | | | | | | | | | |
| Main circuit system | | Transistor inverter (Intelligent power module using IGBT) | | | | | | | | | |
| Braking | | Regeneration brake and dynamic brake | | | | | | | | | |
| Tolerable ambient temperature | °C | 0° to 55°C | | | | | | | | | |
| Tolerable ambient relative humidity | % | 90% or less (with no dew condensation) | | | | | | | | | |
| Storage temperature | °C | -15 to 70°C | | | | | | | | | |
| Storage relative humidity | % | 90% or less | | | | | | | | | |
| Atmosphere | | No harmful gas and dust | | | | | | | | | |
| Tolerable vibration | m/s ² (G) | 4.9m/s ² (0.5G) | | | | | | | | | |
| Tolerable shock | m/s ² (G) | Acceleration: 49m/s ² (5G) | | | | | | | | | |
| Maximum heat dissipation | W | Refer to the servo/spindle system configuration section | | | | | | | | | |
| Weight | kg | 4.5 | | | | | | | | | 5.5 |
| Capacity | kW | 0.1×2 | 0.3 + 0.1 | | 0.3×2 | 0.5 + 0.1 | | 0.5 + 0.3 | | 0.5×2 | 1.0+0.5 |
| Torque limit range | % | 0 ~ 100% | | | | | | | | | |
| Tolerable load inertia | | As a guideline, less than 2.5 times the motor inertia | | | | | | | | | |
| Noise | dB (A) | Less than 55dB | | | | | | | | | |

Continued on the next page.

6. MDS-A/B-V2 Servo Drive

| | Unit | 2-axes amplifier model name | | | | | | | | | |
|---|-------------------------|---|---------|---------|---------|---------|---------|---------|---------|---------|---------|
| | | MDS-A/B- | | | | | | | | | |
| | | V2-1005 | V2-1010 | V2-2010 | | V2-2020 | V2-3510 | | V2-3520 | | V2-3535 |
| Applicable motor | M | L/M | L | M | L/M | L | M | L | M | L/M | |
| | | HA40N | HA80N | HA100N | HA80N | HA100N | HA200N | HA80N | HA200N | HA100N | HA200N |
| | | HA43N | HA83N | HA150NL | HA83N | HA150NL | HA103N | HA83N | HA103N | HA150NL | HA103N |
| | | HA50NL | HA100NL | HA200NL | HA100NL | HA200NL | HA300NL | HA100NL | HA300NL | HA200NL | HA300NL |
| | | | HA53NL | HA103NL | HA53NL | HA103NL | HA203NL | HA53NL | HA203NL | HA103NL | HA203NL |
| | | | HA153NL | | HA153NL | | | | | HA153NL | |
| Output voltage | V | 155V | | | | | | | | | |
| Rated output current | A | 3.4 | 6.8 | 13 | 6.8 | 13 | 16 | 6.8 | 16 | 13 | 16 |
| Continuous output current | A | 5.0 | 8.8 | 18.2 | 8.8 | 18.2 | 25 | 8.8 | 25 | 18.2 | 25 |
| Maximum output current | A | 17 | 28 | 42 | 28 | 42 | 57 | 28 | 57 | 42 | 57 |
| Maximum output torque (During combination with motor) Refer to 5.2VI Specifications for applicable motor. | N·m | 14.220 | 25.497 | 41.792 | 25.497 | 41.972 | 59.820 | 25.497 | 59.821 | 41.972 | 59.821 |
| | | 10.200 | 19.221 | 31.381 | 19.221 | 31.381 | 40.207 | 19.221 | 40.207 | 31.381 | 40.207 |
| | | 13.043 | 20.888 | 31.675 | 20.888 | 31.675 | 51.975 | 20.888 | 51.975 | 31.675 | 51.975 |
| | | | 14.220 | 22.457 | | 22.457 | | | | 22.457 | |
| | | | | 22.849 | | 22.849 | | | | 22.849 | |
| Control system | | Sine wave PWM system | | | | | | | | | |
| Main circuit system | | Transistor inverter (Intelligent power module using IGBT) | | | | | | | | | |
| Braking | | Regeneration brake and dynamic brake | | | | | | | | | |
| Tolerable ambient temperature | °C | 0° to 55°C | | | | | | | | | |
| Tolerable ambient relative humidity | % | 90% or less (with no dew condensation) | | | | | | | | | |
| Storage temperature | °C | -15 to 70°C | | | | | | | | | |
| Storage relative humidity | % | 90% or less | | | | | | | | | |
| Atmosphere | | No harmful gas and dust | | | | | | | | | |
| Tolerable vibration | m/s ² (G) | 4.9m/s ² (0.5G) | | | | | | | | | |
| Tolerable shock | m/s ² (G) | Acceleration: 49m/s ² (5G) | | | | | | | | | |
| Maximum heat dissipation | W | Refer to the servo/spindle system configuration section | | | | | | | | | |
| Weight | kg | 5.5 | | | | | 6.0 | | | | |
| Capacity | kW | 1.0+0.5 | 1.0×2 | 2.0+1.0 | | 2.0×2 | 3.5+1.0 | | 3.5+2.0 | | 3.5×2 |
| Torque limit range | % | 0 ~ 100% | | | | | | | | | |
| Tolerable load inertia | | As a guideline, less than 2.5 times the motor inertia | | | | | | | | | |
| Noise | dB (A) | Less than 55dB | | | | | | | | | |

Continued on the next page.

6. MDS-A/B-V2 Servo Drive

| | Unit | 2-axes amplifier model name | | | |
|--|-------------------------|---|---------|---------|---------|
| | | MDS-B- | | | |
| | | V2-4520 | | V2-4535 | |
| | | L | M | L | M |
| Applicable motor | | HA300N | HA100N | HA300N | HA200N |
| | | HA203N | HA150N | HA203N | HA103N |
| | | HA500NL | HA200NL | HA500NL | HA300NL |
| | | HA303NL | HA103NL | HA303NL | HA203NL |
| | | | HA153NL | | |
| Output voltage | V | 155V | | | |
| Rated output current | A | 28 | 13 | 28 | 16 |
| Continuous output current | A | 44 | 18.2 | 44 | 25 |
| Maximum output current | A | 85 | 42 | 85 | 57 |
| Maximum output torque (During combination with motor) Refer to 5.2VI Specifications for applicable motor. | N·m | 87.573 | 41.972 | 87.573 | 59.821 |
| | | 55.898 | 31.381 | 55.898 | 40.207 |
| | | 72.569 | 31.675 | 72.569 | 51.975 |
| | | | 22.457 | | |
| | | 22.849 | | | |
| Control system | | Sine wave PWM system | | | |
| Main circuit system | | Transistor inverter (Intelligent power module using IGBT) | | | |
| Braking | | Regeneration brake and dynamic brake | | | |
| Tolerable ambient temperature | °C | 0° to 55°C | | | |
| Tolerable ambient relative humidity | % | 90% or less (with no dew condensation) | | | |
| Storage temperature | °C | -15 to 70°C | | | |
| Storage relative humidity | % | 90% or less | | | |
| Atmosphere | | No harmful gas and dust | | | |
| Tolerable vibration | m/s ² (G) | 4.9m/s ² (0.5G) | | | |
| Tolerable shock | m/s ² (G) | Acceleration: 49m/s ² (5G) | | | |
| Maximum heat dissipation | W | Refer to the servo/spindle system configuration section | | | |
| Weight | kg | 6.0 | | | |
| Capacity | kW | 4.5+20 | | 4.5+3.5 | |
| Torque limit range | % | 0 ~ 100% | | | |
| Tolerable load inertia | | As a guideline, less than 2.5 times the motor inertia | | | |
| Noise | dB (A) | Less than 55dB | | | |

6.3 Hardware setting

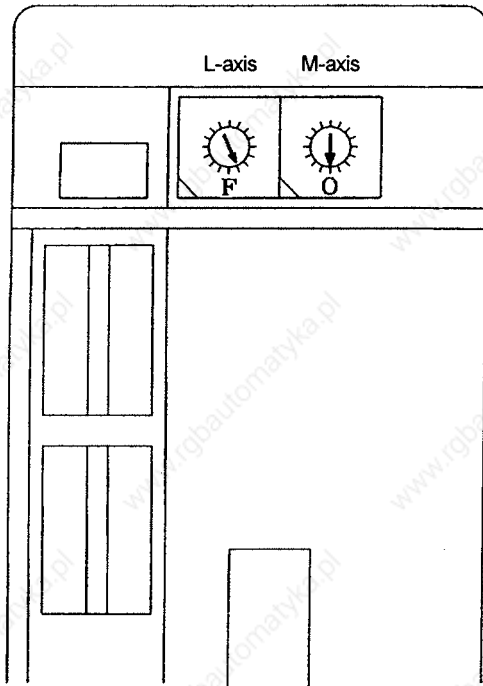



| Function | Setting | Meaning |
|------------------------|-------------------------|------------|
| Axis No. setting CS | 0 | 1st axis |
| | 1 | 2 |
| | 2 | 3 |
| | 3 | 4 |
| | 4 | 5 |
| | 5 | 6 |
| | 6 | 7 |
| | 7 ~ E | Not usable |
| F | Not used axis selection | |

The servo drive axis No. can be set by opening the upper lid (at the right of the LED status display window) on the top of the MDS-A/B-V2 servo drive unit, and turning the rotary switch. When the rotary switch is set to "F" and the servo drive power is turned on, that axis will not be controlled. Thus, set axes that are not being used to "F". (The communication with the NC will not take place during initialization, and an alarm will not occur.)

In the above drawing, the L-axis is the not used axis, and the M-axis is the 1st axis.

6.4 Status display

|  WARNING |
|---|
| <ol style="list-style-type: none"> 1. Do not operate the switches with wet hands. Failure to observe this could lead to electric shocks. 2. Do not operate the unit with the front cover removed. The high voltage terminals and charged sections will be exposed, and could lead to electric shocks. 3. Do not open the front cover while the power is ON or during operation. Failure to observe this could lead to electric shocks. |

|  CAUTION |
|---|
| <ol style="list-style-type: none"> 1. Check the parameters before starting operation. Failure to do so could lead to unforeseen movements of the machine. 2. Do not touch the servo drive unit heat radiating fins, regenerative resistor or servomotor, etc., while the power is turned ON or immediately after turning the power OFF. Some parts are heated to high temperatures, and touching these could lead to burns. |

The state is displayed on the servo drive display with codes and the data is transferred to the NC side.

| Display | Status | Description |
|---------|------------|---|
| AA | INITIALIZE | Waiting for NC power start up (NC power ON → OFF). |
| Ab | INITIALIZE | Waiting for NC power start up (When the drive unit power is turned OFF and ON and the NC power is OFF) |
| AC | INITIALIZE | During parameter transfer request |
| Ad | INITIALIZE | During parameter conversion request |
| AE | INITIALIZE | Waiting for main servo IT start |
| b# | READY OFF | Ready OFF |
| c# | SERVO OFF | Servo OFF |
| d# | SERVO ON | Servo ON |
| F# → 9* | WARNING | Warning being generated |
| F# → E* | WARNING | Warning being generated |
| F# → ** | ALARM | Alarm being generated |

: Axis number

* : Warning number

** : Alarm number (Refer to servo alarm and warning)

6. MDS-A/B-V2 Servo Drive

Examples of MDS-A/B-V2 drive unit status displays

We will assume that the L-axis is the 1st axis and the M-axis is the 2nd axis.

(Example 1) Display when both L-axis and M-axis are in servo ON state.

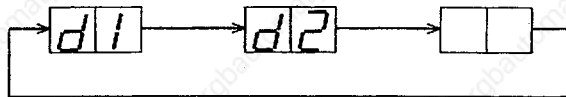

(Example 2) Display when both L-axis and M-axis are in emergency stop state.



(Example 3) Display when the MOTOR OVERHEAT ALARM (46) occurred in the L-axis.

The alarm flickers.



(Example 4) State when the M-axis changeover rotary switch is set to "F" and the MOTOR OVERHEAT ALARM (46) occurred in the L-axis.

The alarm flickers.



(Example 5) Display when M-axis is set to "F" and the L-axis is in the servo ON state.

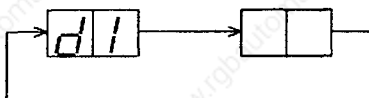

6. MDS-A/B-V2 Servo Drive

6.5 Explanation of terminal block and connectors

| | | Name | Application | Remarks | |
|----------------|--|------|---|---|--|
| Connector | | CN1A | For connection with NC and high-order axis | | |
| | | CN1B | For connection with battery unit and low-order axis | | |
| | | CN9 | For maintenance (not used normally) | | |
| | | CN4 | For connection with power supply unit | | |
| | | CN2L | For connection with L-axis motor end detector | | |
| | | CN3L | For connection with L-axis machine end detector | | |
| | | CN2M | For connection with M-axis motor end detector | | |
| | | CN3M | For connection with M-axis machine end detector | | |
| | | CN20 | External brake output contact point | | |
| Terminal block | | TE2 | L+ | Converter voltage input (+) | |
| | | | L- | Converter voltage input (-) | |
| | | TE3 | L11 | 200VAC single-phase input | |
| | | | L21 | | |
| | | TE1 | MU | U-phase output for M-axis motor drive V-phase output for M-axis motor drive W-phase output for M-axis motor drive U-phase output for L-axis motor drive V-phase output for L-axis motor drive W-phase output for L-axis motor drive Motor grounding | |
| | | | MV | | |
| MW | | | | | |
| LU | | | | | |
| LV | | | | | |
| LW | | | | | |
| ⊕ | | | | | |

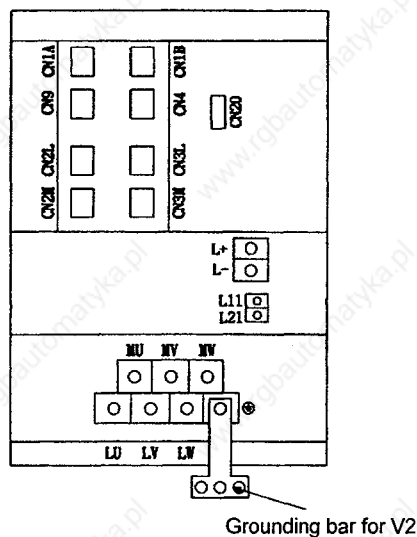

6.6 Main circuit connection

⚠ WARNING

Always ground the servo drive unit and servomotor with Class 3 or higher grounding.

⚠ CAUTION

1. Correctly connect the power phases (U, V, W) of the servo drive unit and servomotor. Failure to do so could cause the servomotor to malfunction.
2. Do not apply a voltage other than that specified to each terminal. Failure to observe this could lead to ruptures or trouble.

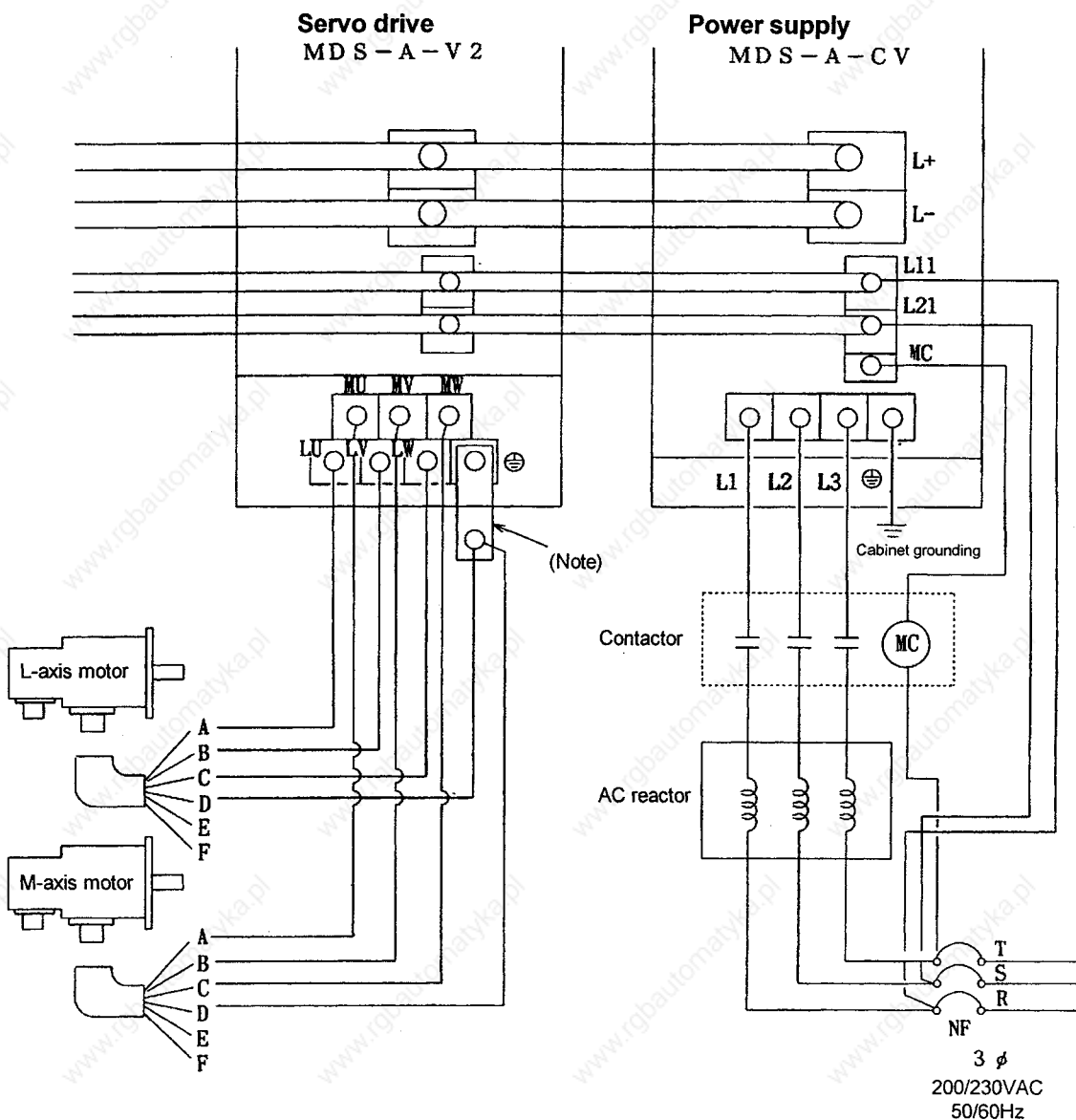

6. MDS-A/B-V2 Servo Drive

- * Starting from production in April 1995, a grounding bar is enclosed with each unit when shipped. Connect the grounding wire as shown, and make sure that the grounding wires are not tightened together.

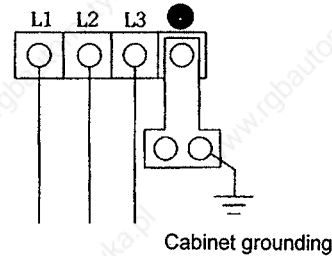
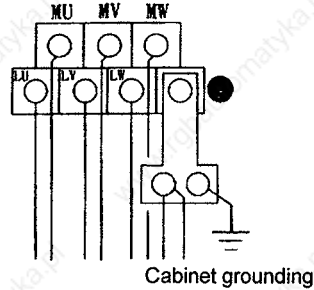

Precautions for connections

- (1) The wires and crimp terminals will differ according to the capacity.
(Refer to section 8.3 in the Chapter I Servo/Spindle System Configuration.)
- (2) Always ground (G) the power supply.
- (3) The phase order of the power supply unit's power supply terminals L1, L2, L3 is random.
- (4) Precautions for connecting servo drive terminals U, V, W
 - a. Always observe the phase order for the servo drive terminals U, V, W and motor side pins A, B, C. The motor may vibrate and rotate suddenly if the phase order is mistaken. The phases cannot be reversed for reverse rotation.
 - b. Never perform connections that might apply the power on the servo drive output terminals U, V, W. Never ground the servo drive output terminals U, V, W or connect so that grounding may occur as this may destroy the servo drive.
 - c. Do not reverse the connections for the servo drive output terminals L-axis (LU, LV, LW) and M-axis (MU, MV, MW). Make sure that the following is established: L-axis motor capacity \geq M-axis motor capacity.
- (5) The Cannon plug used will differ according to the motor. Refer to section 2.8 (3) for the connection drawing of the brake exciter circuit for motor with electromagnetic brake. Refer to section 2.7 (2) for the terminal box type motor.
- (6) Refer to the Chapter I Servo/Spindle System Configuration for the selection of the contactor, AC reactor and non-fuse breaker connected to the power supply.
- (7) Make sure that the specified power is supplied to the servo drive power terminals (L1, L2, L3). If the power does not have the specified voltage, use a transformer.
- (8) Do not directly apply commercial power on the motor.
- (9) Check once again that the wires are connected correctly as indicated in the wiring diagram.

7. Selection of Capacity

7.1 Selection of servo system

7.1.1 Types of drive systems

Examples of the drive system format are shown below.

Types of motion directions

| Linear | | 3. Rotating |
|--|---|---|
| 1. Horizontal | 2. Vertical | |
| <p>Table Speed reduction gear Ball screw PLG M</p> | <p>Counter weight Electromagnetic brake M B PLG</p> | <p>Circular table Worm gear PLG M</p> |

Type of drive systems

| | 1. Ball screw (direct connection) | 2. Ball screw (gear linkage) | 3. Rack and pinion |
|----------------------------------|--|--|--|
| Drive systems | <p>PLG M P_B</p> | <p>PLG M Z₁ P_B Z₂</p> | <p>PLG M Z 1/n P_L</p> |
| Moving amount per motor rotation | $\Delta S = P_B$ | $\Delta S = P_B \cdot \frac{Z_1}{Z_2} = P_B \cdot \frac{1}{n}$ | $\Delta S = P_L \cdot Z \cdot \frac{1}{n}$ |
| | 4. Roll feed | 5. Chain drive (direct connection) | 6. Chain and timing belt drive |
| Drive systems | <p>PLG M 1/n D</p> | <p>PLG M 1/n P_C Z</p> | <p>Z₁ M PLG Z₂ P_r</p> |
| Moving amount per motor rotation | $\Delta S = \pi \cdot D \cdot \frac{1}{n}$ | $\Delta S = P_C \cdot Z \cdot \frac{1}{n}$ | $\Delta S = P_r \cdot Z \cdot \frac{Z_1}{Z_2} = P_r \cdot Z \cdot \frac{1}{n}$ |

As an example, the horizontal drive operation is listed. However, the same drive system is available in the vertical and rotation drive operations.

7. Selection of Capacity

7.1.2 Selection of servomotor

Select a motor that satisfies the following five items so that the performance of the AC servo system can be brought out to the fullest.

(1) Maximum speed

The motor speed during rapid traverse must be within the motor's maximum speed.

$N_{max} \geq N$

N_{max} : Motor maximum speed

If the drive system is the gear linkage ball screw, calculate the motor speed with the following equation, and confirm that the calculated value is less than the motor's maximum speed. Note that the maximum speed may be restricted by the detector.

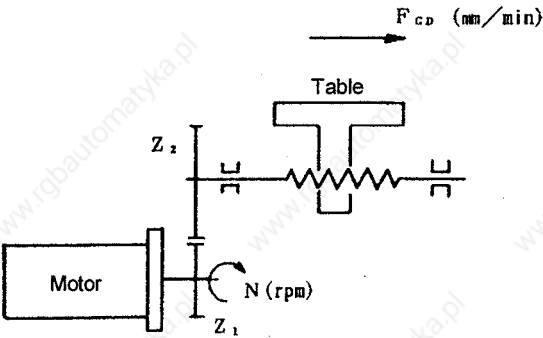
| Configuration on machine side | Calculation equation |
|--|---|
|  | $N = \frac{F_{CO}}{P_B} \times n \leq N_{max}$ <p> N_{max} : Motor maximum speed (r/min) N : Motor speed (r/min) F_{CO} : Rapid traverse rate (mm/min) P_B : Feed screw pitch (mm/rev) n : Drive gear ratio Z_1 : Number of gear teeth on motor shaft Z_2 : Number of gear teeth on feed screw shaft $n = \frac{\text{Motor speed}}{\text{Feed screw speed}} = \frac{Z_2}{Z_1}$ </p> |

7. Selection of Capacity

(2) Motor shaft conversion load inertia

The load inertia should be within 2.5 times the motor inertia. Use is possible if it exceeds 2.5 times, but the servo adjustment range will be reduced, and the time constants must be increased.

$$J_M \times 2.5 \geq J_L$$

- J_L : Maximum load inertia (motor shaft conversion) [$\times 10^{-4} \text{kg}\cdot\text{m}^2$]
- J_M : Motor inertia [$\times 10^{-4} \text{kg}\cdot\text{m}^2$]
- J_M : Find the motor inertia from the motor data sheet. When using the brakes, add the brake inertia.
- J_L : Obtain the maximum load inertia with the following equation. The example shows the ball screw drive system.

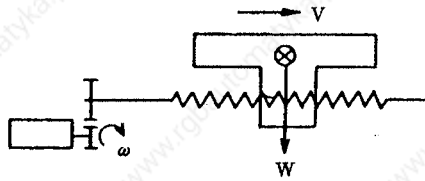
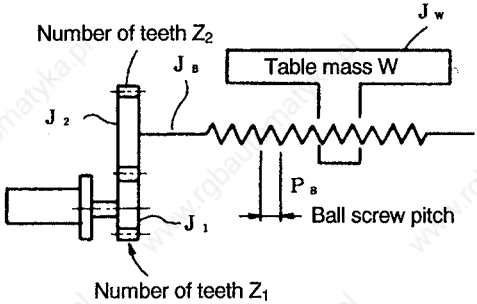
| Item | Configuration on machine side | Calculation equation |
|---|---|---|
| Load inertia of substance linearly moved (Motor shaft conversion) |  | $J_L = 100W \cdot \left[\frac{10V}{60\omega} \right]^2 = 100W \cdot \left[\frac{10V}{2\pi N} \right]^2$ $= 100W \cdot \left[\frac{P}{2\pi \times 10} \right]^2$ <p>where</p> <ul style="list-style-type: none"> J_L : Load inertia ($\times 10^{-4} \text{kg}\cdot\text{m}^2$) V: Speed of substance linearly moved (mm/min) ω : Angular speed of motor (rad/s) N : Motor speed (r/min) P : Moving amount of substance linearly moved per motor rotation (mm) W : Mass of substance linearly moved (kg) |
| Example of calculating load inertia |  | $J_L = J_1 + \left[\frac{Z_1}{Z_2} \right]^2 (J_2 + J_B + J_W)$ $= J_1 + \left[\frac{Z_1}{Z_2} \right]^2 \left\{ J_2 + J_B + 100W \cdot \left[\frac{P}{2\pi \times 10} \right]^2 \right\}$ <p>where</p> <ul style="list-style-type: none"> J_L : Load inertia ($\times 10^{-4} \text{kg}\cdot\text{m}^2$) J_1: Pinion inertia ($\times 10^{-4} \text{kg}\cdot\text{m}^2$) J_2: Gear inertia ($\times 10^{-4} \text{kg}\cdot\text{m}^2$) J_B: Ball screw inertial ($\times 10^{-4} \text{kg}\cdot\text{m}^2$) J_W: Inertia adjacent to ball screw on table ($\times 10^{-4} \text{kg}\cdot\text{m}^2$) P_B: Ball screw pitch (mm) W : Table mass (kg) |

7. Selection of Capacity

(3) Acceleration/deceleration torque

The acceleration/deceleration torque should be within 80% of the amplifier's maximum output torque.

The following calculation equation is used for the acceleration/deceleration torque regardless of the index acceleration or linear acceleration.

$$T_{Amax} \times 0.8 \geq \frac{2\pi N (J_L + J_M)}{60T_s} + T_F$$

- N : Motor speed during rapid traverse [r/min]
- T_S : Acceleration/deceleration time constant during rapid traverse [s]
- T_F : Motor conversion load torque during rapid traverse [N·m]
- T_{Amax} : Amplifier maximum output torque (when used in combination with motor) [N·m]
- T_{Amax} : Find the amplifier maximum output torque from the servo drive unit specifications.

(4) Continuous effective load torque

The continuous effective load torque should be within 80% of the motor rated torque (during normal stall).

$$T_{MS} \times 0.8 \geq Trms$$

- T_{MS} : Motor rated torque [N·m]
- Trms : Continuous effective load torque [N·m]

The continuous effective load torque is calculated as shown below from the machine's operation pattern.

| Operation pattern | Calculation equation |
|-------------------|---|
| | $Trms = \sqrt{\frac{X}{t_0}}$ $X = (T_a + T_f)^2 t_1 + T_f^2 t_2 + (T_d - T_f)^2 t_3 + T_o^2 t_4 + (T_{ac} + T_f)^2 t_5 + (T_c + T_f)^2 t_6 + T_f^2 t_7 + (T_{dc} - T_f)^2 t_8 + T_o^2 t_9$ <p>where</p> <ul style="list-style-type: none"> Trms : Continuous effective load torque (N·m) T_a : Acceleration torque (N·m) T_d : Deceleration torque (N·m) T_f : Frictional load torque (N·m) T_o : Load torque in stop state (N·m) T_{ac} : Acceleration torque in cutting state (N·m) T_{dc} : Deceleration torque in cutting state (N·m) T_c : Cutting torque (N·m) |

7. Selection of Capacity

However, if the cutting maximum torque and maximum duty (%) are known, the selection conditions can be found easily with the following equation.

$$T_{MS} \times 0.8 \geq T_{rms} = T_c \sqrt{\frac{D}{100}}$$

- T_{MS} : Motor rated torque [N·m]
- T_{rms} : Continuous effective torque [N·m]
- T_c : Operational maximum torque [N·m]
- D : Maximum duty [%]

(5) Duty ON time

The maximum duty ON time should be within the tolerable time listed in the motor data sheet. However, this does not need to be checked if the cutting maximum torque is less than the rated torque of 100%.

$$T_{LOn} \leq T_{MOn}$$

- T_{LOn} : ON time of maximum duty [min] (machine manufacturer specification)
- T_{MOn} : ON time of motor tolerable duty [min] (data sheet)

Example)

In HA23N, when the maximum cutting torque T_c is 1.37 [N·m] and the duty D is 40 [%], the ON time of the tolerable duty becomes:

$$\text{Torque percent} = \frac{1.37}{0.98} = 1.4 \rightarrow 140\%$$

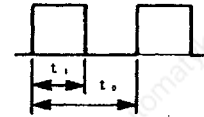

From the chart, $T_{MOn} = 5$ [min]

$$\text{Duty percent} = \frac{t_1}{t_0} \times 100\%$$

t_1 : ON time (min)

HA23/t th = 20.25min

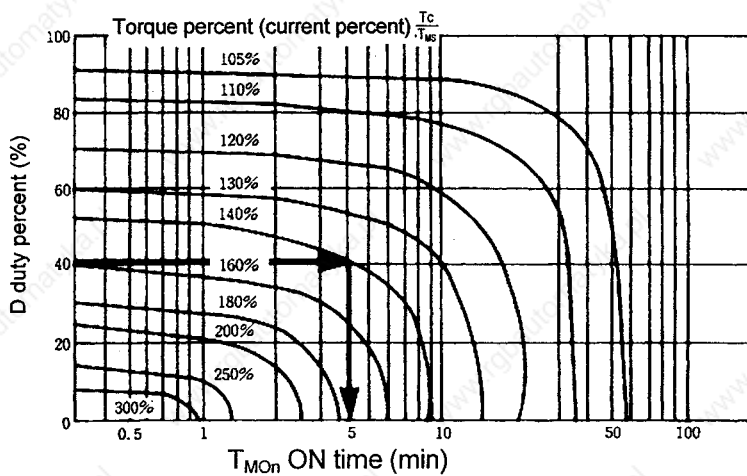

7. Selection of Capacity

(6) Unbalance load torque

The unbalance load torque must be kept to within 50% of the motor rated torque (at normal stall).

$$T_{MS} \times 0.5 \geq T_o$$

T_{MS} : Motor rated torque [kg·cm]
 T_o : Unbalance load torque when stopped

(7) Example of selection

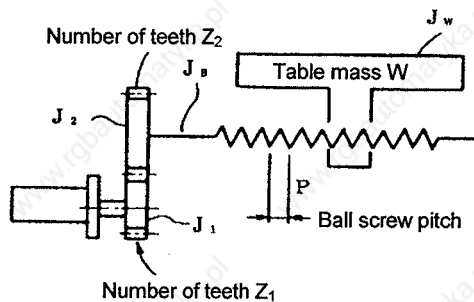

When the following data is known for the above drive system:

| | |
|--|---|
| Gear ratio | $N = 3/5$ |
| Ball screw pitch | $P = 10\text{mm}$ |
| Rapid traverse rate | $F = 12000\text{mm/min}$ |
| Table mass | $W = 170\text{kg}$ |
| Ball screw inertia | $J_B = 7.45 \times 10^{-4} \text{kg}\cdot\text{m}^2$ |
| Gear inertia | $J_2 = 45.11 \times 10^{-4} \text{kg}\cdot\text{m}^2$ |
| Pinion inertia | $J_1 = 6.28 \times 10^{-4} \text{kg}\cdot\text{m}^2$ |
| Motor shaft conversion torque during rapid traverse | $T_F = 2.94\text{N}\cdot\text{m}$ |
| Motor shaft conversion torque during maximum cutting | $T_C = 31.58\text{N}\cdot\text{m}$ |
| Maximum cutting duty | $D = 20\%$ |

The motor maximum speed is :

$$12000 \times \frac{1}{10} \times \frac{5}{3} = 2000 \text{ rpm}$$

The motor shaft conversion load inertia is:

$$J_L = J_1 + N^2 \cdot \left\{ J_2 + J_B + 100W \cdot \left[\frac{P}{2\pi \times 10} \right]^2 \right\} = 180.22 \times 10^{-4} \text{kg}\cdot\text{m}^2$$

Thus, the motor inertia J_M must satisfy the following:

$$J_M \geq \frac{J_L}{2.5} = 72.09 \times 10^{-4} \text{kg}\cdot\text{m}^2$$

7. Selection of Capacity

From this, HA200N (inertia = $131.0 \times 10^{-4} \text{ kg} \cdot \text{m}^2$) can be selected.
The maximum torque T_{max} during acceleration/deceleration is :

$$\begin{aligned} T_{\text{max}} &= \frac{2\pi N (J_L + J_M)}{60T_s} + T_F \\ &= \frac{6.52}{T_s} + 2.94 \end{aligned}$$

The drive unit that corresponds to HA200N is A-V1-35, and the drive unit's maximum output torque is $59.820 \text{ N} \cdot \text{m}$ (T_{amax}) as found in the drive unit specifications.

From $T_{\text{amax}} \times 0.8 \geq T_{\text{max}}$:

$$47.86 \geq \frac{6.52}{T_s} + 2.94$$

Therefore, $T_s \geq 145 \text{ msec}$

Thus, the rapid traverse acceleration/deceleration time constant is 150 msec :
The continuous effective load torque T_{rms} is :

$$\begin{aligned} T_{\text{rms}} &= T_c \sqrt{\frac{D}{100}} \\ &= 31.58 \sqrt{\frac{20}{100}} \\ &= 14.12 \end{aligned}$$

The rated torque T_{MS} for HA200N is $22.6 \text{ N} \cdot \text{m}$.

So the $T_{\text{MS}} \times 0.8 \geq T_{\text{rms}}$ conditions are satisfied.

The maximum cutting torque T_c ($31.58 \text{ N} \cdot \text{m}$) is 140% of the rated torque ($22.6 \text{ N} \cdot \text{m}$), so the duty cycle ON time is 40 minutes or longer from the HA200N characteristic graph.

Thus, it can be seen that the V1-35 and motor HA200N are compatible.

7. Selection of Capacity

(7) Reference

1. Calculation of load inertia

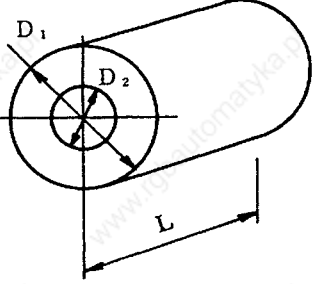
| Item | Configuration on machine side | Calculation equation |
|-----------------------|--|--|
| Cylinder load inertia |  <p style="text-align: center;">See [Appendix 1].</p> | $J_L = \frac{10 \cdot \pi \cdot \rho \cdot L}{32} (D_1^4 - D_2^4)$ $= \frac{W}{8g} (D_1^2 + D_2^2)$ <p>where</p> <p>J_L : Load inertia ($\times 10^{-4} \text{kg} \cdot \text{m}^2$) ρ : Specific gravity (kg/m^3) L : Length of cylinder (mm) D_1 : Outer diameter of cylinder (mm) D_2 : Inner diameter of cylinder (mm) W : Mass (kg)</p> <p>Specific gravities of materials</p> <p>Steel : $7.8 \times 10^{-9} \text{kg}/\text{m}^3$ Aluminum : $2.7 \times 10^{-9} \text{kg}/\text{m}^3$ Copper : $8.96 \times 10^{-9} \text{kg}/\text{m}^3$</p> |

Although the inertia is expressed by inertia moment, or GD^2 , their concept is the same. In this chapter, the relation of the moment of inertia and GD^2 is as follows for convenience.

- (1) Inertia moment ($J \text{ kg} \cdot \text{m}^2$) = (mass kg) \times (rotation radius m)²
- (2) GD^2 ($GD^2 \text{ kg} \cdot \text{m}^2$) = (mass kg) \times (rotation diameter m)²
- (3) Conversion equation of J and GD^2 $J = \frac{GD^2}{4}$

7. Selection of Capacity

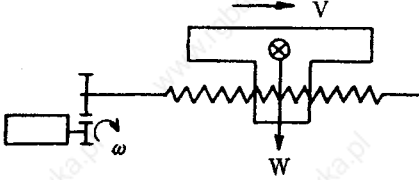
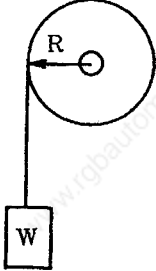
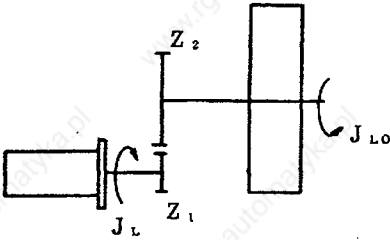
| Item | Configuration on machine side | Calculation equation |
|---|---|--|
| Load inertia of substance linearly moved (Motor shaft conversion) |  | $J_L = 100W \cdot \left[\frac{10V}{60\omega} \right]^2 = 100W \cdot \left[\frac{10V}{2\pi N} \right]^2$ $= 100W \cdot \left[\frac{P}{2\pi \times 10} \right]^2$ where J_L : Load inertia ($\times 10^{-4} \text{kg}\cdot\text{m}^2$) V : Speed of substance linearly moved (mm/min) ω : Angular speed of motor (rad/s) N : Motor speed (r/min) P : Moving amount of substance linearly moved per motor rotation (mm) W : Mass of substance linearly moved (kg) |
| Load inertia of substance lifted up |  | $J_L = W \cdot R^2 + J_P$ where J_L : Load inertia ($\times 10^{-4} \text{kg}\cdot\text{m}^2$) J_P : Inertia of pulley ($\times 10^{-4} \text{kg}\cdot\text{m}^2$) R : Radius of pulley (mm) |
| Load inertia J_{LO} is decelerated (accelerated) and connected to motor shaft |  | $J_L = \left[\frac{Z_1}{Z_2} \right]^2 \times J_{LO}$ where J_L : Load inertia ($\times 10^{-4} \text{kg}\cdot\text{m}^2$) (Motor shaft conversion) J_{LO} : Load inertia at rotation center of rotating substance ($\times 10^{-4} \text{kg}\cdot\text{m}^2$) Z_1 : Number of gear teeth on motor shaft side Z_2 : Number of gear teeth on deceleration (deceleration) side |

7. Selection of Capacity

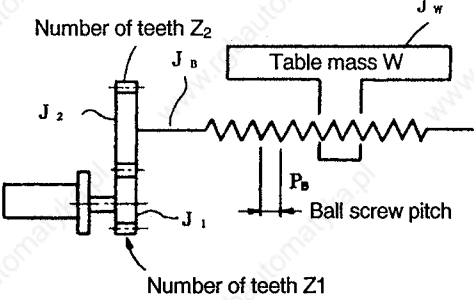
| Item | Configuration on machine side | Calculation equation |
|--|---|---|
| <p>Example of calculating load inertia</p> |  | $J_L = J_1 + \left(\frac{Z_1}{Z_2}\right)^2 (J_2 + J_B + J_W)$ $= J_1 + \left(\frac{Z_1}{Z_2}\right)^2 \left\{ J_2 + J_B + 100W \cdot \left[\frac{P}{2\pi \times 10}\right]^2 \right\}$ <p>where</p> <ul style="list-style-type: none"> J_L : Load inertia ($\times 10^{-4} \text{kg}\cdot\text{m}^2$) J_1: Pinion inertia ($\times 10^{-4} \text{kg}\cdot\text{m}^2$) J_2: Gear inertia ($\times 10^{-4} \text{kg}\cdot\text{m}^2$) J_B: Ball screw inertial ($\times 10^{-4} \text{kg}\cdot\text{m}^2$) J_W: Inertia adjacent to ball screw on table ($\times 10^{-4} \text{kg}\cdot\text{m}^2$) P_B: Ball screw pitch (mm) W : Table mass (kg) |

7. Selection of Capacity

2. Example of load torque calculation

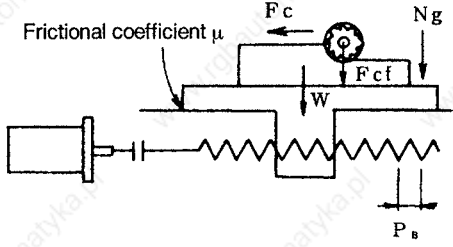
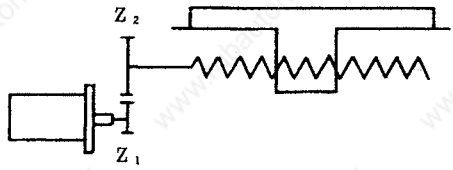
| Item | Configuration on machine side | Calculation equation |
|--|--|--|
| Load torque of machine linearly moved (motor shaft conversion) |  | $T_L = \frac{F \cdot P}{2 \times 10^{-3} \cdot \pi \eta} + T_F$ <p>where</p> <ul style="list-style-type: none"> T_L : Motor shaft conversion load torque (N·m) F : Axial force of machine linearly moved (N) P : Movement of machine per motor rotation (mm/rev) η : Ball screw efficiency T_F : Motor shaft conversion frictional load torque (N·m) |
| | <p>• When a drive gear is used:</p>  | $T_L = \frac{F \cdot P_B}{2 \times 10^{-3} \pi} \cdot \frac{Z_1}{Z_2} + T_F$ <p>where</p> <ul style="list-style-type: none"> T_L : Load torque converted into motor shaft (N·m) F : Axial force of machine linearly moved (N) P_B : Ball screw pitch (mm/rev) η : Efficiency of ball screw and drive gear Z_1, Z_2 : Number of drive gear teeth T_F : Load torque converted into motor shaft (N·m) $F = F_c + \mu (W + N_g + F_{cf})$ <p>where</p> <ul style="list-style-type: none"> F_c : Axial component force in cutting state (N) W : Full mass of table (kg) N_g : Gib tightening force on table guide surface (kg) F_{cf} : Component force perpendicular to shaft in cutting state (back component) (kg) μ : Dynamic friction coefficient |

7. Selection of Capacity

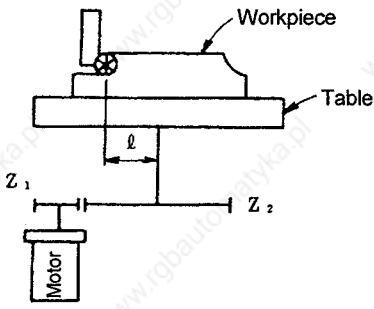
| Item | Configuration on machine side | Calculation equation |
|--|--|---|
| Load torque of rotating machine (motor shaft conversion) |  <p style="text-align: center;"> Workpiece Table l Z_1 Motor Z_2 </p> | $T_L = F \cdot \frac{l}{10^3} \cdot \frac{Z_1}{Z_2} \cdot \frac{1}{\eta} + T_F$ <p>where</p> <ul style="list-style-type: none"> T_L : Motor shaft conversion load torque (N·m) F : Tangential direction force of rotating machine (N) l : Distance from rotation center to working point of F (mm) Z_1 : Number of gear teeth on motor side Z_2 : Number of gear teeth on table side η : Efficiency of drive system T_F : Motor shaft conversion frictional load torque (N·m) |

Precautions for calculating load torque

- (1) The maximum value of the load torque should be selected in the actual machine operation state. When the selected load torque is actually smaller than that used, an overload may occur.
- (2) When the machine table is separated from the cutting position, the frictional load torque may be momentarily varied by the cutting force on the table guide surface.

7. Selection of Capacity

7.2 Determining the coasting amount with emergency stop

When the system detects an abnormality, the machine's motor is stopped by a dynamic brake. The coasting amount of the machine can be obtained by the following equation.

$$L_{\max} = \frac{F_{GO} \times 10^3}{60} \left\{ 0.03 + (AN^2 + B) \left(1 + \frac{J_L}{J_M} \right) \times 1.1 \right\}$$

where

- L_{max} : Coasting amount of machine (mm)
- F_{GO} : Feedrate (rapid traverse) (m/min)
- N : Motor speed (maximum speed) (r/min)
- A : Coefficient (see the following table)
- B : Coefficient (see the following table)
- J_L : Motor shaft conversion load inertia (×10⁻⁴kg·m²)
- J_M : Motor shaft rotor inertia (×10⁻⁴kg·m²)

Note : L_{max} deviates for ±10% depending on the induced voltage constant.

| Motor model | Motor inertia J _M × 10 ⁻⁴ kg·m ² | Coefficients | |
|--------------|--|-------------------------|--------------------------|
| | | A | B |
| HA053 | 0.18 | 0.13 × 10 ⁻⁹ | 13.18 × 10 ⁻³ |
| HA13 | 0.36 | 0.15 × 10 ⁻⁹ | 8.39 × 10 ⁻³ |
| HA23N | 0.98 | 0.25 × 10 ⁻⁹ | 6.66 × 10 ⁻³ |
| HA33N | 1.96 | 0.39 × 10 ⁻⁹ | 4.28 × 10 ⁻³ |
| HA40N | 9.8 | 2.07 × 10 ⁻⁹ | 11.47 × 10 ⁻³ |
| HA43N | 9.8 | 1.79 × 10 ⁻⁹ | 13.48 × 10 ⁻³ |
| HA80N | 19.6 | 1.77 × 10 ⁻⁹ | 9.73 × 10 ⁻³ |
| HA83N | 19.6 | 1.44 × 10 ⁻⁹ | 12.54 × 10 ⁻³ |
| HA100N | 68.6 | 4.82 × 10 ⁻⁹ | 16.68 × 10 ⁻³ |
| HA103N | 68.6 | 3.87 × 10 ⁻⁹ | 27.72 × 10 ⁻³ |
| HA200N | 131.0 | 2.65 × 10 ⁻⁹ | 22.61 × 10 ⁻³ |
| HA203N | 131.0 | 1.24 × 10 ⁻⁹ | 49.97 × 10 ⁻³ |
| HA300N | 192.0 | 1.71 × 10 ⁻⁹ | 31.05 × 10 ⁻³ |
| HA700N | 254.0 | 1.31 × 10 ⁻⁹ | 37.84 × 10 ⁻³ |
| HA900N | 319.0 | 1.39 × 10 ⁻⁹ | 44.01 × 10 ⁻³ |
| HA303N | 192.0 | 0.68 × 10 ⁻⁹ | 62.16 × 10 ⁻³ |
| HA703N | 254.0 | 0.69 × 10 ⁻⁹ | 73.15 × 10 ⁻³ |
| HA50NL | 2.75 | 2.31 × 10 ⁻⁹ | 2.56 × 10 ⁻³ |
| HA100NL | 5.49 | 2.04 × 10 ⁻⁹ | 2.92 × 10 ⁻³ |
| HA150NL | 8.24 | 3.54 × 10 ⁻⁹ | 3.26 × 10 ⁻³ |
| HA200NL | 19.6 | 1.90 × 10 ⁻⁹ | 6.56 × 10 ⁻³ |
| HA300NL | 29.4 | 1.88 × 10 ⁻⁹ | 6.42 × 10 ⁻³ |
| HA500NL | 88.3 | 2.12 × 10 ⁻⁹ | 19.40 × 10 ⁻³ |
| HA53NL | 2.7 | 1.57 × 10 ⁻⁹ | 3.17 × 10 ⁻³ |
| HA103NL | 5.5 | 1.16 × 10 ⁻⁹ | 3.85 × 10 ⁻³ |
| HA153NL | 8.2 | 0.89 × 10 ⁻⁹ | 4.81 × 10 ⁻³ |
| HA203NL | 19.6 | 1.17 × 10 ⁻⁹ | 7.46 × 10 ⁻³ |
| HA303NL | 29.4 | 1.04 × 10 ⁻⁹ | 9.58 × 10 ⁻³ |
| HA503NL | 88.3 | 1.32 × 10 ⁻⁹ | 26.25 × 10 ⁻³ |
| HA-LH11K2-S1 | 118.0 | 2.31 × 10 ⁻⁹ | 11.32 × 10 ⁻³ |
| HA-LH15K2-S1 | 290.0 | 3.73 × 10 ⁻⁹ | 20.36 × 10 ⁻³ |

IV. MDS-A-SP, MDS-B-SP

Spindle System Section

MDS-A-CSP

Large Capacity Spindle Drive Section

1. Outline

1.1 Features of the MDS-A-SP and MDS-B-SP spindle system

- (1) The converter that was conventionally built into the spindle controller has been installed in the power supply unit (MDS-A-CV and MDS-B-CV), and can be used commonly with the other axis drive units. This allows great reductions in size and weight.
- (2) The speed response has been improved by using a high-speed CPU, and the cutting performance and cutting precision during positioning control has been improved.
- (3) A high-speed orientation method that allows direct orientation from high-speeds has been incorporated allowing smooth operations and minimum orientation times.
- (4) All spindle parameters can be set from the NC CRT screen thus enhancing the operability.

1.2 Precautions for use

- (1) The motor rated output is guaranteed with the controller rated input voltage (200/220/230VAC). The rated output may not be achieved if the input voltage fluctuates and drops to 200VAC or less.
- (2) A harmonic chopper voltage that is PWM controlled is applied on the motor so a harmonic leakage current will flow during motor operation.
If a general purpose leakage breaker is used, the operation may malfunction due to this harmonic, so use a leakage breaker for inverters. (Refer to the Maintenance Manual BNP-B2046 for details.)
- (3) A harmonic leakage current will also flow to the grounding wire between the motor and controller, and if this grounding wire is placed near the NC CRT screen, the CRT screen may malfunction due to the magnetic field of the leakage current.
Separate the grounding wire and NC CRT screen as far as possible.
- (4) Noise may occur in AM radio broadcasts due to the electromagnetic wave noise generated from the motor and controller.
Separate radios and the motor and controller as far as possible.
A filter for radio noise measures is available as an option, so use one if necessary.

1. Outline

1.3 Model configuration

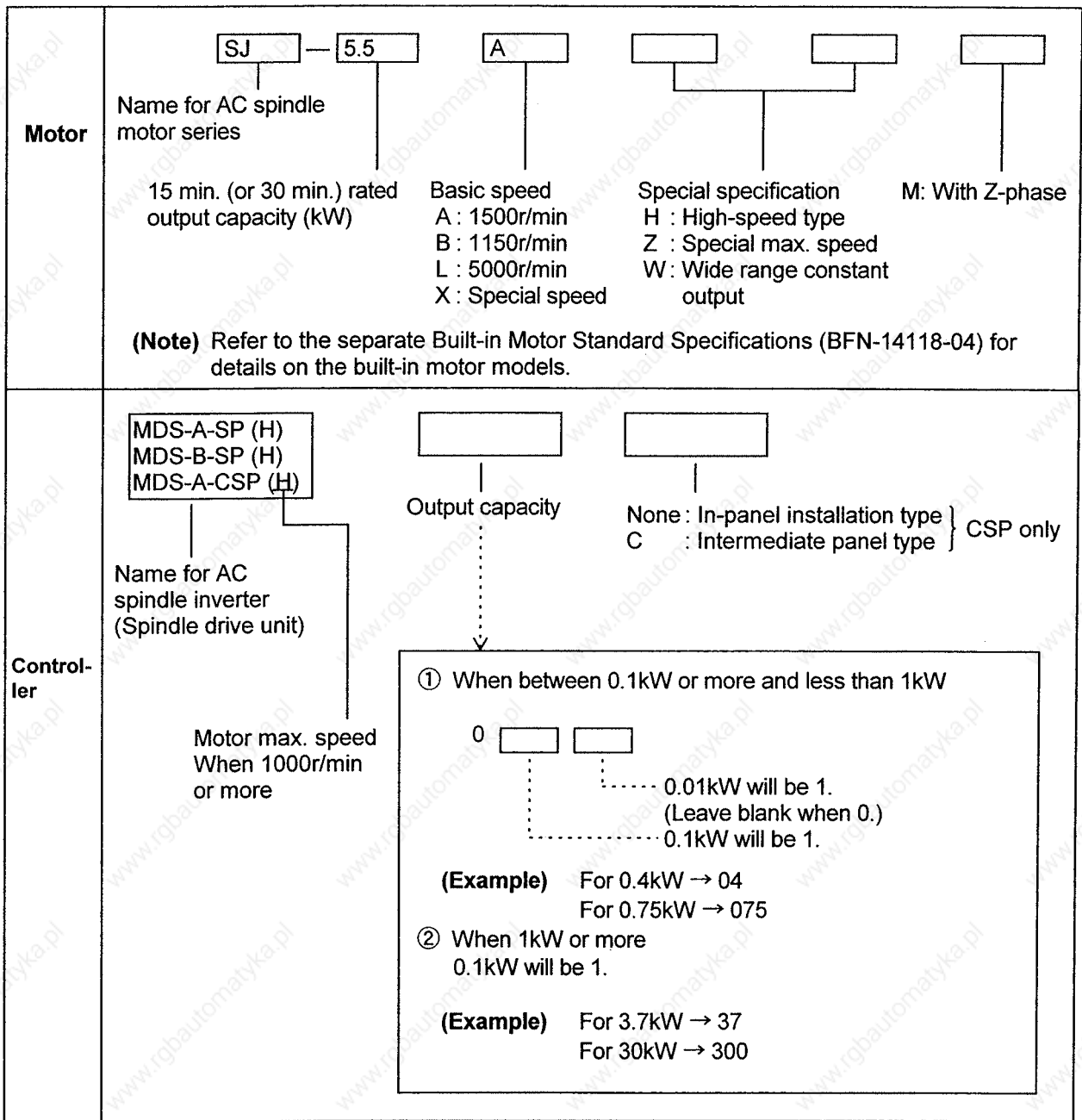

1.4 Configuration

1.4.1 Basic configuration (no added functions)

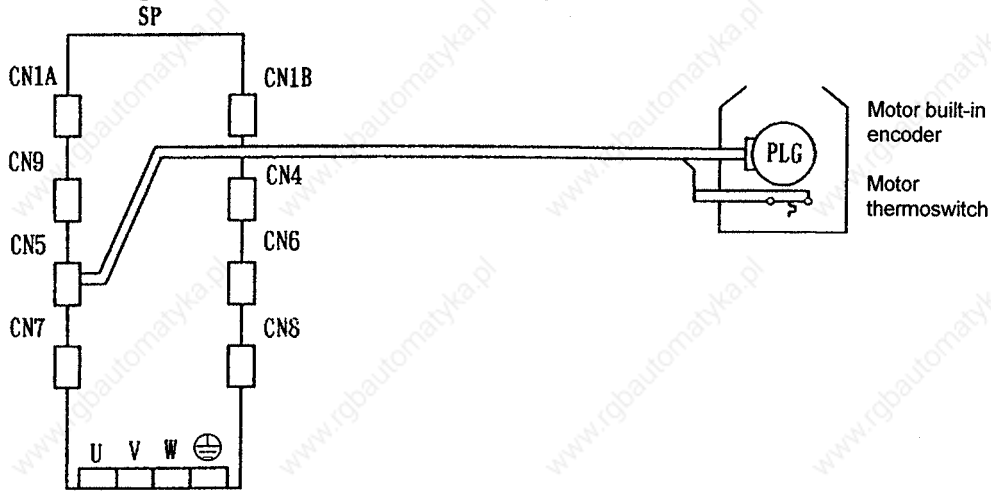

1.4.2 With orientation function

(1) Magnesensor orient (1-point) specifications

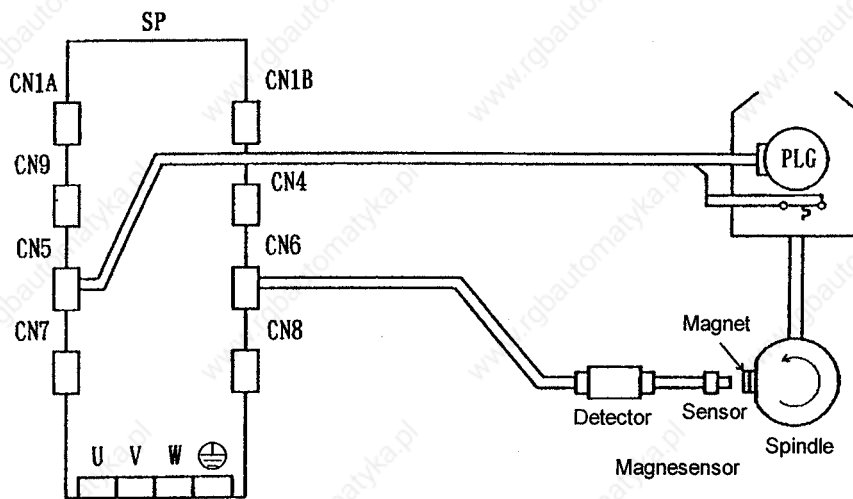

(2) Encoder orient (4096-point) specifications/with index function

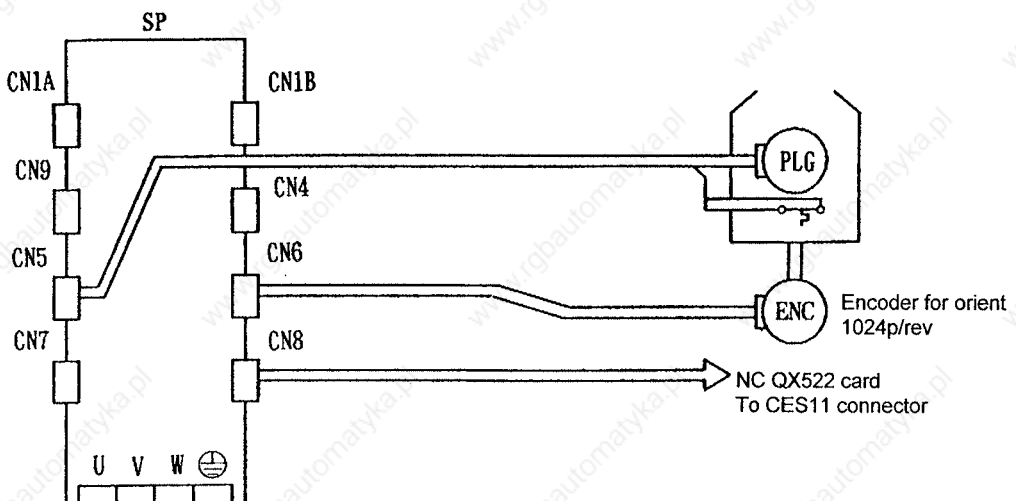

1. Outline

(3) Z-phase motor built-in encoder orient (4096-point) specifications/with index function

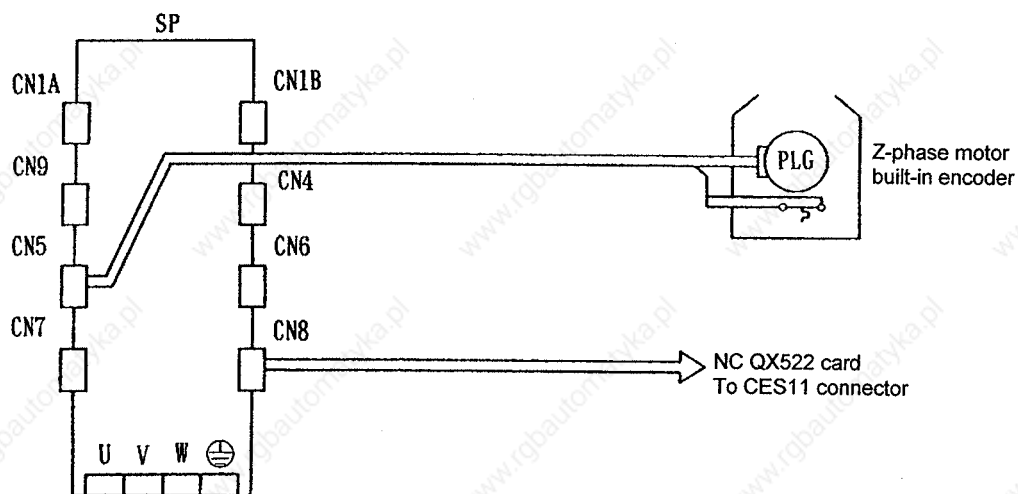

Note) Multipoint orient using the Z-phase motor built-in encoder is applicable only when spindle to motor shaft speed ratio is 1:1.

(4) Magnesensor orient (1-point) specifications + motor speed feedback output (for spindle speed indication and synchronous speed signal)

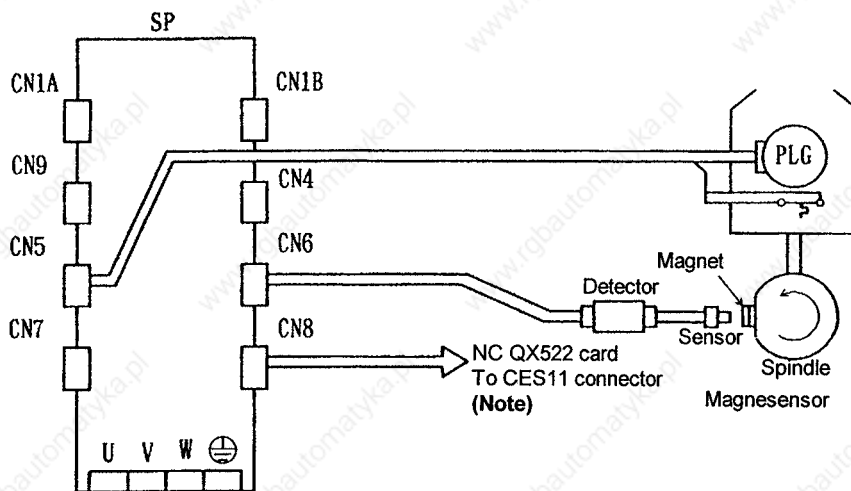

Note) The No. of pulses output to NC will differ according to the speed ratio between the spindle and motor shaft.

1.4.3 High-speed synchronous tap/spindle synchronization/with orientation function

(1) Motor built-in encoder high-speed synchronous tap/spindle synchronization and magnet-sensor orient (1-point) specifications

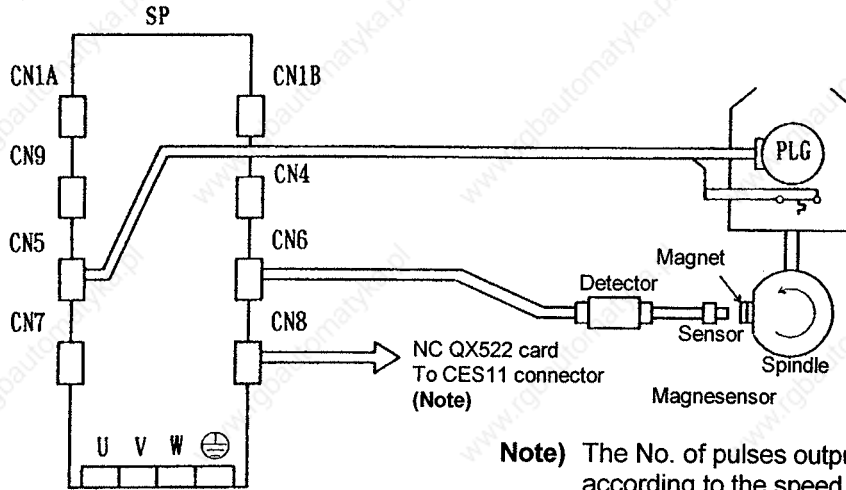

Note) The No. of pulses output to NC will differ according to the speed ratio between the spindle and motor shaft.

(2) Encoder high-speed synchronous tap/spindle synchronization and orient (4096-point) specifications/ with index function

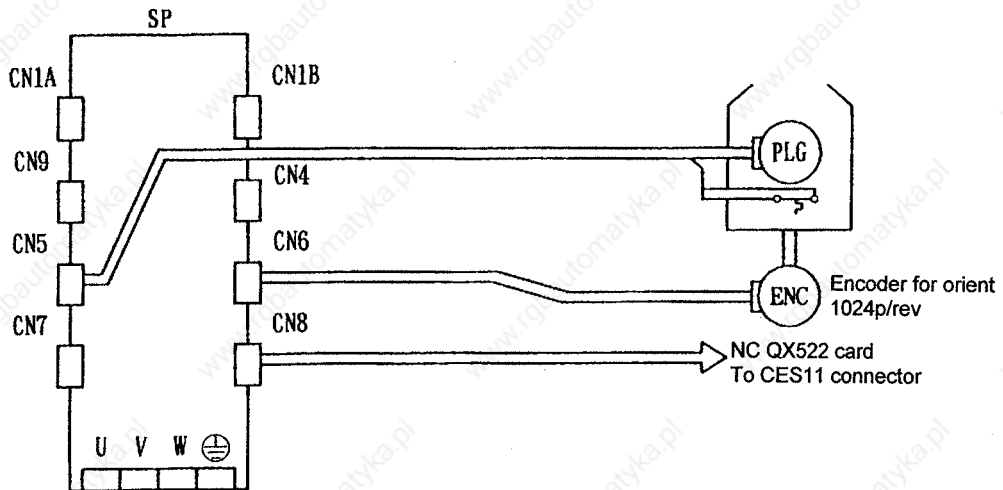

(3) Z-phase motor built-in encoder high-speed synchronous tap/spindle synchronization and orient (4096-point) specifications/with index function

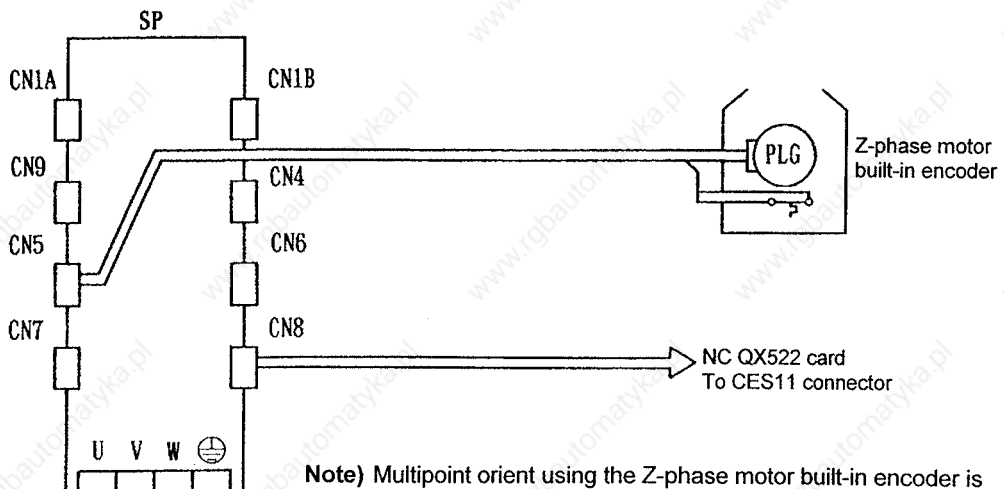

Note) Multipoint orient using the Z-phase motor built-in encoder is applicable only when spindle to motor speed ratio is 1:1.

1. Outline

1.4.6 MBE90K encoder C-axis control/with orientation function

(1) MBE90K encoder C-axis control and orient (4096-point) specifications/with index function

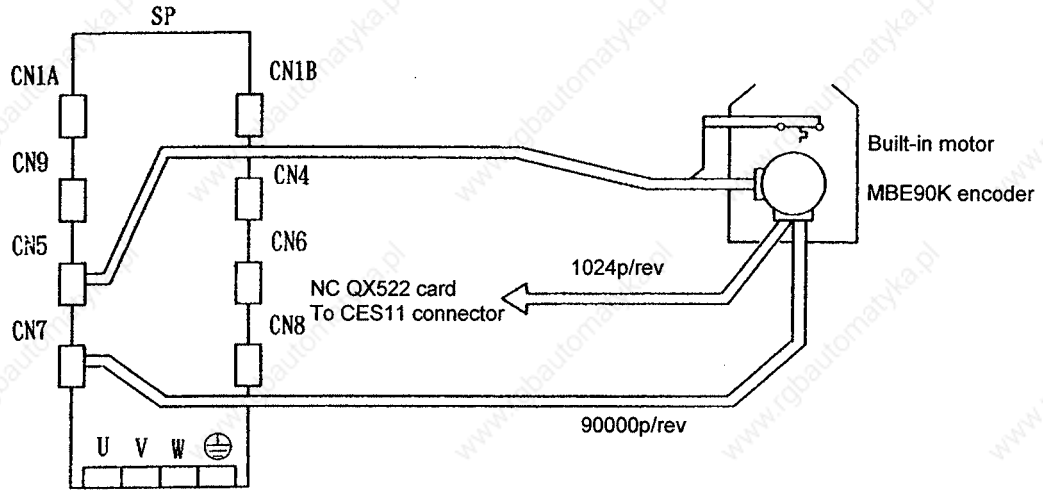

1.4.7 MBE90K encoder C-axis control and high-speed synchronous tap/spindle synchronization/with orientation function

(1) MBE90K encoder C-axis control and high-speed synchronous tap/spindle synchronization and orient (4096-point) specifications/with index function

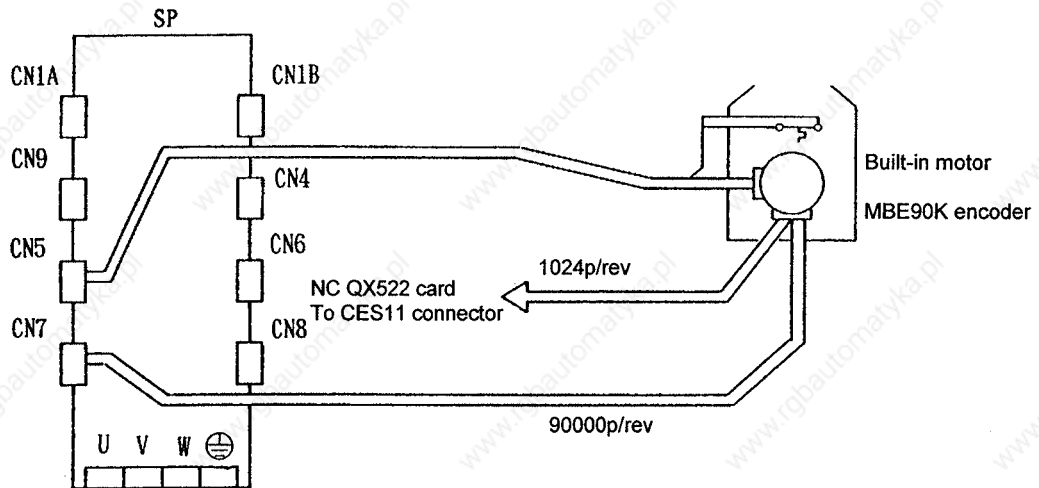

Note) Refer to the MBE90K (built-in C-axis encoder) Specifications and Instruction Manual [BNP-A2993-41] for details on the MBE90K wiring.

1. Outline

1.4.8 MHE90K encoder C-axis control/with orientation function

(1) MHE90K encoder C-axis control and orient (4096-point) specifications/with index function

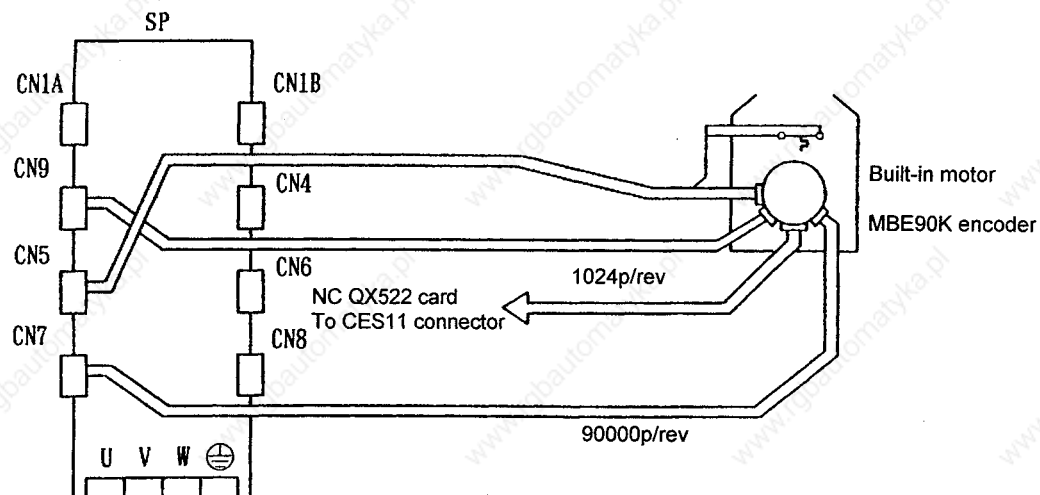

1.4.9 MHE90K encoder C-axis control and high-speed synchronous tap/spindle synchronization/with orientation function

(1) MHE90K encoder C-axis control and high-speed synchronous tap/spindle synchronization and orient (4096-point) specifications/with index function

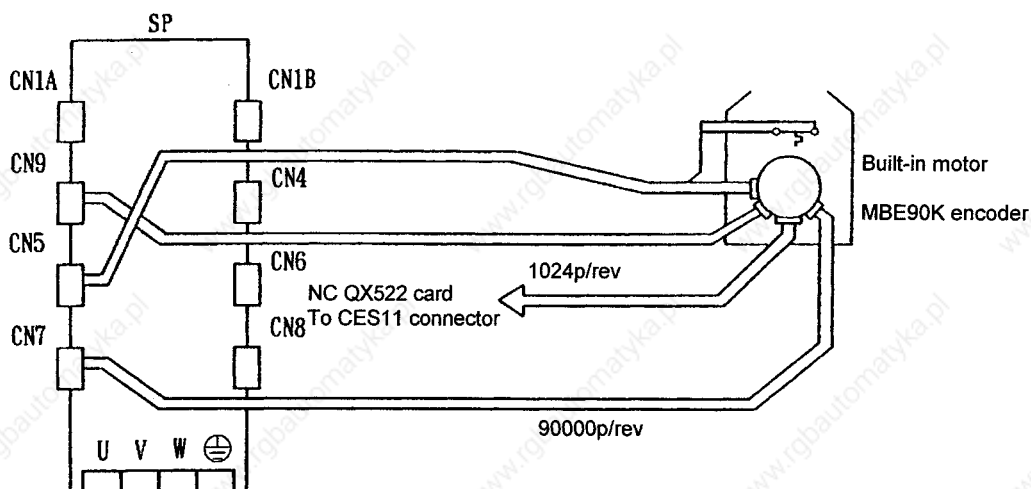

Note) Refer to the MHE90K (built-in C-axis encoder) Specifications and Instruction Manual [BNP-A2993-44] for details on the MHE90K wiring.

- * The cable for outputting signals from CN8 to NC and the cable for directly connecting the detector and NC are not necessarily required for 1.4.1 to 1.4.9. Connect only when required due to the applications. (Spindle speed indication and synchronous speed signal)

1. Outline

1.5 Device-to-device connections

CAUTION
 Do not apply a voltage other than that specified to each terminal. Failure to observe this could lead to ruptures or trouble.

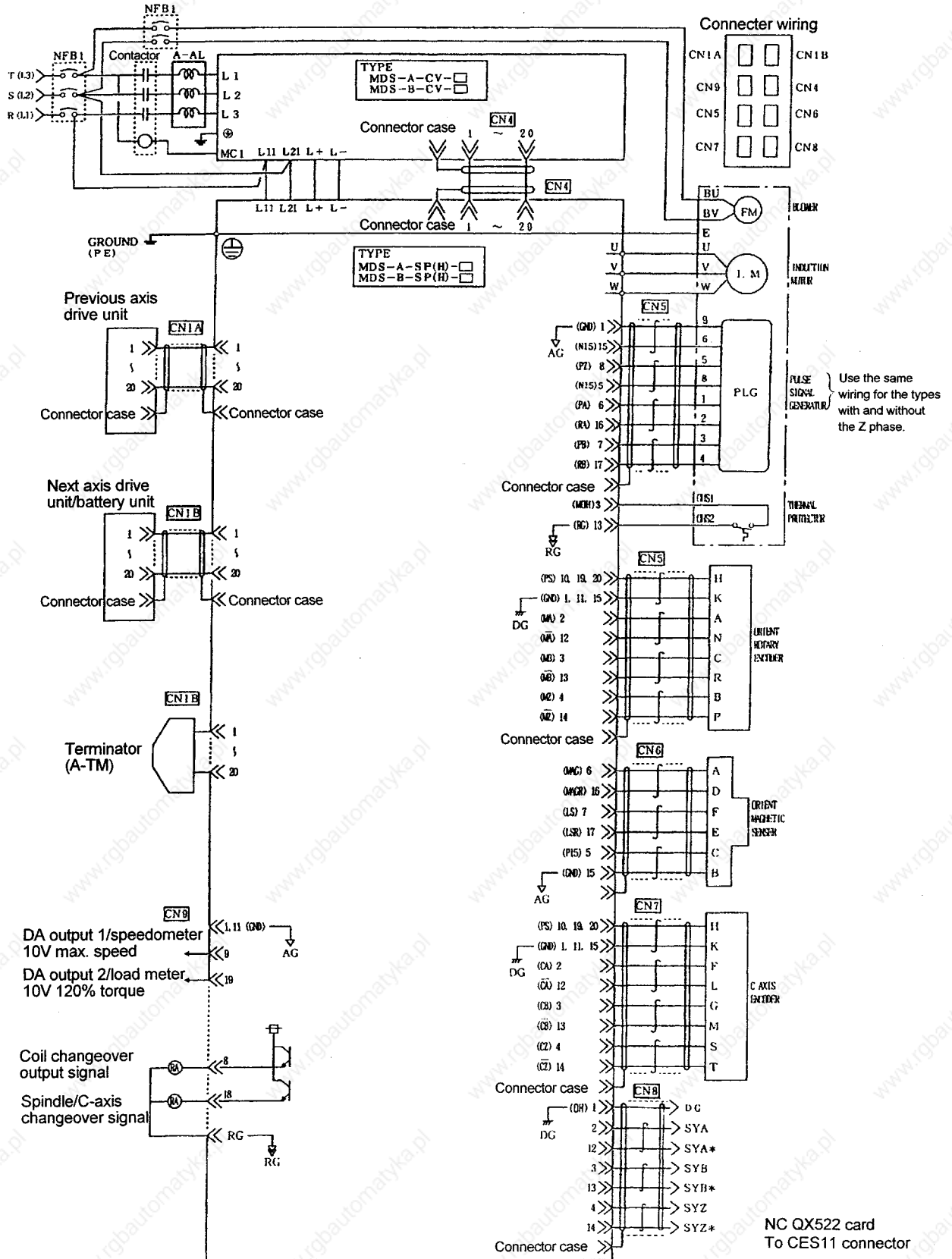

2. Specifications

2. Specifications

2.1 AC spindle motor and controller specifications

| Item | | Series | Base speed 1500r/min series | | | | | | | | |
|------------------------------|--------------------------|---|-----------------------------|----------------|----------------|----------------|----------------|----------------|---------------|---------------|-------|
| | | Model | SJ- | | | | | | | | |
| Output capacity | Cont. rating (HP)/(kW) | 5.5A | 7.5A | 11AP | 11A | 15A | 18.5A | 22AP | 22A | 26A | 30A |
| | 30 min. rating (HP)/(kW) | 7/5.5 | 10/7.5 | 15/11 | 15/11 | 20/15 | 20/18.5 | 30/22 | 30/22 | 35/26 | 40/30 |
| | 50% ED rating r/min | | | | | | | | | | |
| Speed | Basic speed [r/min] | 1500 | | | | | | | | | |
| | Max. speed [r/min] | 8000 | | | 6000 | | | 4500 | | | |
| Frame No. | | A112 | B112 | | B132 | | C132 | | A160 | | B160 |
| Cont. rated torque | N·m [kg·m] | 23.5 (2.40) | 35.0 (3.57) | 44.5 (4.54) | 47.7 (4.87) | 70.1 (7.15) | 95.5 (9.74) | 95.5 (9.74) | 118 (12.0) | 140 (14.3) | |
| GD ² | [kg·m ²] | 0.08 | 0.10 | 0.12 | 0.17 | 0.21 | 0.27 | 0.32 | 0.55 | | 0.69 |
| Weight | [kg] | 60 | 70 | 75 | 100 | 110 | 130 | 150 | 175 | | 200 |
| Tolerable radial load | [kg] | 150 | 200 | | 300 | | | | | | |
| Cooling fan | [W] | 35 | | | | | | 130 | | | |
| Vibration | | V5 | | | | | | V10 | | | |
| Noise | [dB] (A) | 75 | | | | | | 80 | | | |
| Installation | | Horizontal or vertical (output shaft down) | | | | | | | | | |
| Overload withstand level | | 120% of 30 min. rated output, 1 min. | | | | | | | | | |
| Ambient temperature | (°C) | 0 ~ 40 | | | | | | | | | |
| Insulation class | | F class | | | | | | | | | |
| Paint color | | Munsell 5.27G 2.46/0.21 | | | | | | | | | |
| Accessories | | Pulse generator and overheat detector | | | | | | | | | |
| Lubrication of bearings | | Grease | | | | | | | | | |
| Output characteristic | | Fig. 1 | | | Fig. 2 | | | Fig. 3 | | | |
| Item | | Series | SP- | | | | | | | | |
| | | Model | 55 | 75 | 110 | 150 | 185 | 220 | 260 | 300 | |
| Main circuit | | IGBT IPM sinusoidal wave PWM inverter | | | | | | | | | |
| Control circuit | | Pulse generator speed feedback, digital closed-loop control, vector control | | | | | | | | | |
| Braking | | Power regenerative braking | | | | | | | | | |
| Speed control range | [r/min] | 35 ~ 8000 | | | 35 ~ 6000 | | | 35 ~ 4500 | | | |
| Speed fluctuation rate | | Max. 0.2% of maximum speed (under load varying from 10% to 100%) | | | | | | | | | |
| Speed command | | Serial connection with M500 Series CNC | | | | | | | | | |
| Ambient temperature/humidity | | 0°C ~ 55°C / 90% or less (with no dew condensation) | | | | | | | | | |
| Storage temperature/humidity | | -15°C ~ 70°C / 90% or less (with no dew condensation) | | | | | | | | | |
| Atmosphere | | To be free from detrimental gas and dust (to conform with "grade C" environmental resistance specified by JEM1103) | | | | | | | | | |
| Vibration | | 4.90m/s ² (0.5G) or less | | | | | | | | | |
| Noise | | Less than 55dB | | | | | | | | | |

(Note 1) The motor rated output is guaranteed with the power supply unit rated input voltage (200/220/230VAC). The rated output may not be achieved if the input voltage fluctuates and drops to 200VAC or less.

(Note 2) Contact Mitsubishi when a rated output range other than 1:8, or 1:12 is required.

(Note 3) The 50% ED rating is ON for five minutes and OFF for five minutes in the 10 minute cycle time.

2. Specifications

| Series | | Wide (1:8) rated output series | | | | | Wide (1:12) rated output series | | | |
|--------------------------------------|--------------------------|---|----------------|----------------|---------------|---------------|---------------------------------|---------------|---------------|---------------|
| | | SJ- | | | | | SJ- | | | |
| Item | | 5.5XW8 | 7.5XW8 | 11XW8 | 15XW8 | 18.5XW8 | 5.5XWC | 7.5XWC | 11XWC | 15XWC |
| Output capacity | Cont. rating (HP)/(kW) | 5/3.7 | 7/5.5 | 10/7.5 | 15/11 | 20/15 | 5/3.7 | 7/5.5 | 10/7.5 | 15/11 |
| | 30 min. rating (HP)/(kW) | 7/5.5 | 10/7.5 | 15/11 | 20/15 | 25/18.5 | 5/5.5 | 10/7.5 | 15/11 | 20/15 |
| | 50% ED rating | | | | | | | | | |
| Speed | Basic speed [r/min] | 750 | | | 625 | | 500 | 400 | | |
| | Max. speed [r/min] | 6000 | | | 5000 | | 6000 | 4800 | | |
| Frame No. | | B112 | B132 | C132 | B160 | B180 | B132 | A160 | B180 | A200 |
| Cont. rated torque N·m (kg·m) | | 47.0 (4.80) | 70.0 (7.14) | 95.5 (9.74) | 169 (17.1) | 228 (23.3) | 70.5 (7.20) | 131 (13.4) | 179 (18.3) | 262 (26.8) |
| GD ² [kg·m ²] | | 0.12 | 0.21 | 0.32 | 0.69 | 1.36 | 0.21 | 0.55 | 1.26 | 2.19 |
| Weight [kg] | | 75 | 110 | 150 | 200 | 300 | 110 | 175 | 300 | 390 |
| Tolerable radial load [kg] | | 200 | 300 | | | 400 | 300 | | 400 | 600 |
| Cooling fan [W] | | 35 | | | 130 | | 35 | 180 | | 3ø60 |
| Vibration | | V5 | | | V10 | | V5 | V10 | | |
| Noise [dB] (A) | | 75 | | | 80 | | 75 | 80 | | 85 |
| Installation | | Horizontal or vertical (output shaft down) | | | | | | | | |
| Overload withstand level | | 120% of 30 min. rated output, 1 min. | | | | | | | | |
| Ambient temperature (°C) | | 0 ~ 40 | | | | | | | | |
| Insulation class | | F class | | | | | | | | |
| Paint color | | Munsell 5.27G 2.46/0.21 | | | | | | | | |
| Accessories | | Pulse generator and overheat detector | | | | | | | | |
| Lubrication of bearings | | Grease | | | | | | | | |
| Output characteristic | | Fig. 4 | | | Fig. 5 | | Fig. 6 | Fig. 7 | | |
| Series | | SP- | | | | | | | | |
| Item | | | | | | | | | | |
| Model | | 110 | 220 | 260 | 300 | 110 | 150 | 260 | 300 | |
| Main circuit | | IGBT IPM sinusoidal wave PWM inverter | | | | | | | | |
| Control circuit | | Pulse generator speed feedback, digital closed-loop control, vector control | | | | | | | | |
| Braking | | Power regenerative braking | | | | | | | | |
| Speed control range [r/min] | | 35 ~ 6000 | | | 35 ~ 5000 | | 35~6000 | 35 ~ 4800 | | |
| Speed fluctuation rate | | Max. 0.2% of maximum speed (under load varying from 10% to 100%) | | | | | | | | |
| Speed command | | Serial connection with M500 Series CNC | | | | | | | | |
| Ambient temperature/humidity | | 0°C ~ 55°C / 90% or less (with no dew condensation) | | | | | | | | |
| Storage temperature/humidity | | -15°C ~ 70°C / 90% or less (with no dew condensation) | | | | | | | | |
| Atmosphere | | To be free from detrimental gas and dust (to conform with "grade C" environmental resistance specified by JEM1103) | | | | | | | | |
| Vibration | | 4.90m/s ² (0.5G) or less | | | | | | | | |
| Noise | | Less than 55dB | | | | | | | | |

- (Note 1) The motor rated output is guaranteed with the power supply unit rated input voltage (200/220/230VAC). The rated output may not be achieved if the input voltage fluctuates and drops to 200VAC or less.
- (Note 2) Contact Mitsubishi when a rated output range other than 1:8, or 1:12 is required.
- (Note 3) The 50% ED rating is ON for five minutes and OFF for five minutes in the 10 minute cycle time.

2. Specifications

| Series | | High-speed series | | | | | |
|------------------------------|---|---|-------------|---------------------|-------------|-------------|-------------|
| Item | | | | | | | |
| Model | SJ- | | | | | | |
| | 5.5AZ | 7.5AZ | 5.5LH | 7.5LH | 11LH | 15LH | |
| Output capacity | Cont. rating (HP)/(kW) | 5/3.7 | 7/5.5 | 5/3.7 | 7/5.5 | 10/7.5 | 15/11 |
| | 30 min. rating (HP)/(kW) | 7/5.5 | 10/7.5 | 7/5.5 | 10/7.5 | 15/11 | 20/15 |
| | 50% ED rating | | | | | | |
| Speed | Basic speed [r/min] | 1500 | | 5000 | | 5000 | |
| | Max. speed [r/min] | 10000 | | 20000 | | 15000 | |
| Frame No. | A112 | B112 | A100 | B100 | B132 | C132 | |
| Cont. rated torque | N·m (kg·m) | 23.5 (2.4) | 35.0 (3.57) | 7.06 (0.72) | 1.05 (1.07) | 14.3 (1.46) | 21.0 (2.14) |
| GD ² | [kg·m ²] | 0.08 | 0.10 | 0.02 | 0.025 | 0.07 | 0.095 |
| Weight | [kg] | 60 | 70 | 60 | 65 | 95 | 115 |
| Tolerable radial load | [kg] | 140 | | 5 | | | |
| Cooling fan | [W] | 35 | | | | | |
| Vibration | | V5 | | | | | |
| Noise | [dB] (A) | 75 | | | 85 | | |
| Installation | | Horizontal or vertical (output shaft down) | | | | | |
| Overload withstand level | | 120% of 30 min. rated output, 1 min. | | | | | |
| Ambient temperature | (°C) | 0 ~ 40 | | | | | |
| Insulation class | | F class | | | | | |
| Paint color | | Munsell 5.27G 2.46/0.21 | | | | | |
| Accessories | | Pulse generator and overheat detector | | | | | |
| Lubrication of bearings | | Grease | | Oil air lubrication | | | |
| Output characteristic | | Fig. 8 | | Fig. 9 | | Fig. 10 | |
| Series | | SP/SPH- | | | | | |
| Item | | | | | | | |
| Model | 55 | 75 | | 110 | | 150 | |
| Main circuit | IGBT IPM sinusoidal wave PWM inverter | | | | | | |
| Control circuit | Pulse generator speed feedback, digital closed-loop control, vector control | | | | | | |
| Braking | Power regenerative braking | | | | | | |
| Speed control range | [r/min] | 35 ~ 10000 | | 35 ~ 20000 | | 35 ~ 15000 | |
| Speed fluctuation rate | | Max. 0.2% of maximum speed (under load varying from 10% to 100%) | | | | | |
| Speed command | | Serial connection with M500 Series CNC | | | | | |
| Ambient temperature/humidity | | 0°C ~ 55°C / 90% or less (with no dew condensation) | | | | | |
| Storage temperature/humidity | | -15°C ~ 70°C / 90% or less (with no dew condensation) | | | | | |
| Atmosphere | | To be free from detrimental gas and dust (to conform with "grade C" environmental resistance specified by JEM1103) | | | | | |
| Vibration | | 4.90m/s ² (0.5G) or less | | | | | |
| Noise | | Less than 55dB | | | | | |

(Note 1) The motor rated output is guaranteed with the power supply unit rated input voltage (200/220/230VAC). The rated output may not be achieved if the input voltage fluctuates and drops to 200VAC or less.

(Note 2) Contact Mitsubishi when a rated output range other than 1:8, or 1:12 is required.

(Note 3) The 50% ED rating is ON for five minutes and OFF for five minutes in the 10 minute cycle time.

2. Specifications

| Series | | SJ-N series | | | | | | | | |
|----------------------------------|------------------------|---|----------------|----------------|----------------|----------------|------------|------------|----------------|--|
| Item | | | | | | | | | | |
| Model | SJ-N | | | | | | | | | |
| | | 0.75A | 1.5A | 2.2X | 2.2A | 3.7A | 5.5AP | 5.5A | 7.5A | |
| Output capacity | Cont. rating kW (HP) | 0.4 (0.5) | 0.75 (1.0) | 1.5 (2.0) | 1.5 (2.0) | 2.2 (3.0) | 3.0 (4.0) | 3.7 (5.0) | 5.5 (7.4) | |
| | 30 min. rating kW (HP) | 0.75 (1.0) | 1.5 (2.0) | 2.2 (3.0) | 2.2 (3.0) | 3.7 (5.0) | 5.5 (7.4) | 5.5 (7.4) | 7.5 (10.1) | |
| | 50% ED rating | 10 min | 10 min | 15 min | 15 min | 15 min | 15 min | 30 min | 30 min | |
| Speed | Basic speed [r/min] | 1500 | | 3000 | | 1500 | | | | |
| | Max. speed [r/min] | 10000 | | | | | | 8000 | | |
| Frame No. | | B71 | C71 | C71 | A90 | B90 | C90 | A112 | B112 | |
| Cont. rated torque | N·m (kg·m) | 2.55 (0.26) | 4.70 (0.48) | 3.53 (0.36) | 9.51 (0.97) | 14.0 (1.43) | 23.5 (2.4) | 23.5 (2.4) | 35.0 (3.57) | |
| GD ² | [kg·m ²] | 0.0045 | 0.0086 | 0.0086 | 0.017 | 0.021 | 0.045 | 0.058 | 0.071 | |
| Weight | [kg] | 15 | 20 | 20 | 33 | 37 | 45 | 63 | 74 | |
| Tolerable radial load | [kg] | 50 | | | 100 | | | 150 | 200 | |
| Cooling fan | [W] | 20 | | | 40 | | 55 | 35 | | |
| Vibration | | V5 | | | | | | | | |
| Noise | [dB] (A) | 75 | | | | | | | | |
| Installation | | Horizontal or vertical (output shaft down) | | | | | | | | |
| Overload withstand level | | 120% of 30 min. rated output, 1 min. | | | | | | | | |
| Ambient temperature | (°C) | 0 ~ 40 | | | | | | | | |
| Insulation class | | F class | | | | | | | | |
| Paint color | | Munsell 5.27G 2.46/0.21 | | | | | | | | |
| Accessories | | Pulse generator and heat detector | | | | | | | | |
| Lubrication of bearings | | Grease | | | | | | | | |
| Output characteristic | | Fig. 11 | | | | | | | | |
| Series | | SP- | | | | | | | | |
| Item | | | | | | | | | | |
| Model | | | | | | | | | | |
| | | 075 | 15 | 22 | | 37 | 55 | | 75 | |
| Main circuit | | IGBT IPM sinusoidal wave PWM inverter | | | | | | | | |
| Control circuit | | Pulse generator speed feedback, digital closed-loop control, vector control | | | | | | | | |
| Braking | | Regenerative braking (resistance discharged) | | | | | | | | |
| Speed control range | [r/min] | 35 ~ 10000 | | | | | 35 ~ 8000 | | | |
| Speed fluctuation rate | | Max. 0.2% of maximum speed (under load varying from 10% to 100%) | | | | | | | | |
| Speed command | | Serial connection with M500 Series CNC | | | | | | | | |
| Ambient temperature/ humidity | | 0°C ~ 55°C / 90% or less (with no dew condensation) | | | | | | | | |
| Storage temperature/humidity | | -15°C ~ 70°C / 90% or less (with no dew condensation) | | | | | | | | |
| Atmosphere | | To be free from detrimental gas and dust (to conform with "grade C" environmental resistance specified by JEM1103) | | | | | | | | |
| Vibration | | 4.90m/s ² (0.5G) or less | | | | | | | | |
| Noise | | Less than 55dB | | | | | | | | |

(Note 1) The motor rated output is guaranteed with the power supply unit rated input voltage (200/220/230VAC). The rated output may not be achieved if the input voltage fluctuates and drops to 200VAC or less.

(Note 2) For speeds faster than 6000min⁻¹, the speed will be the reduced output calculated with rated output $\times \frac{6000}{\text{speed}}$.

(Note 3) The 50% ED rating is ON for five minutes and OFF for five minutes in the 10 minute cycle time.

2. Specifications

2.2 Output characteristics

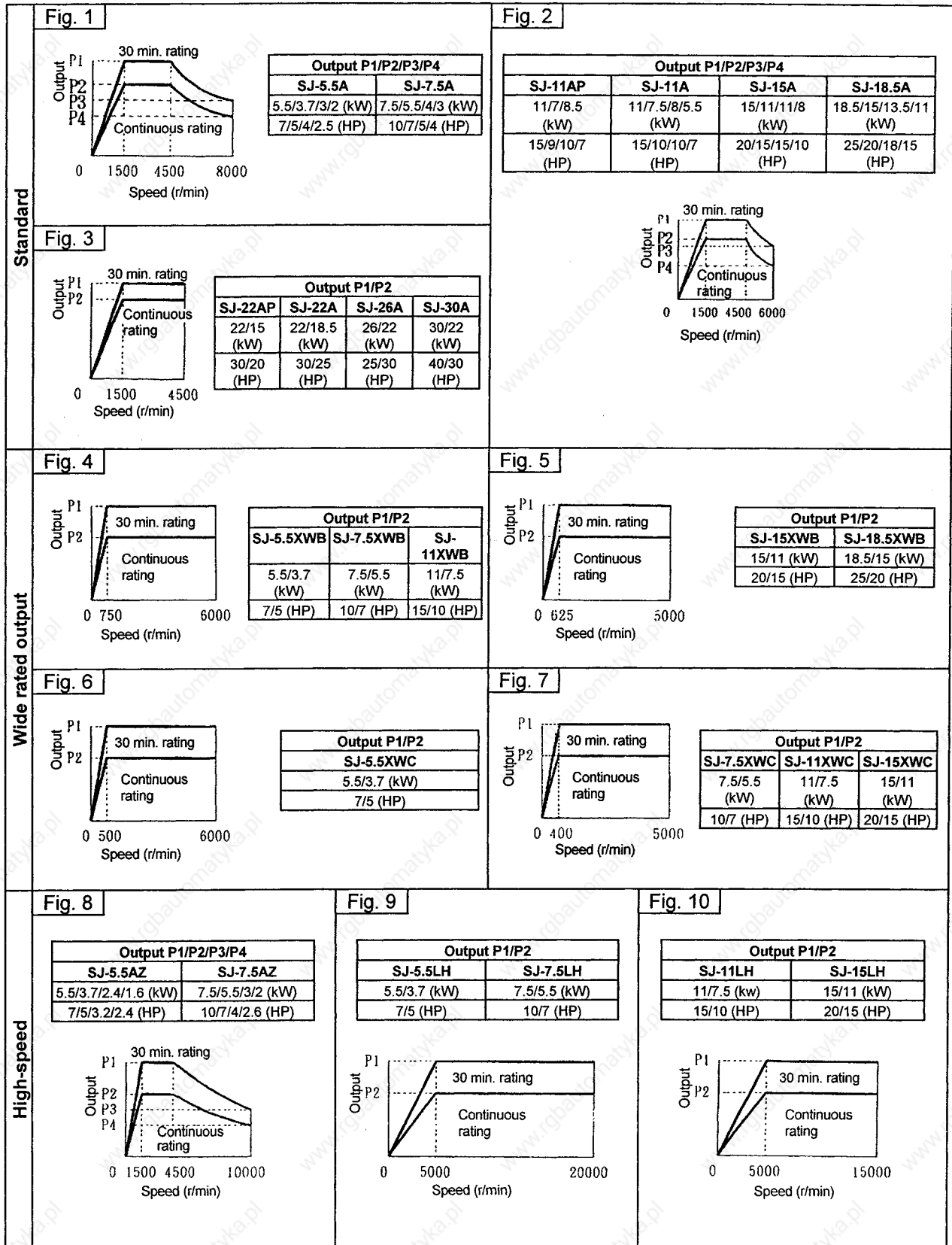

2. Specifications

Fig.11

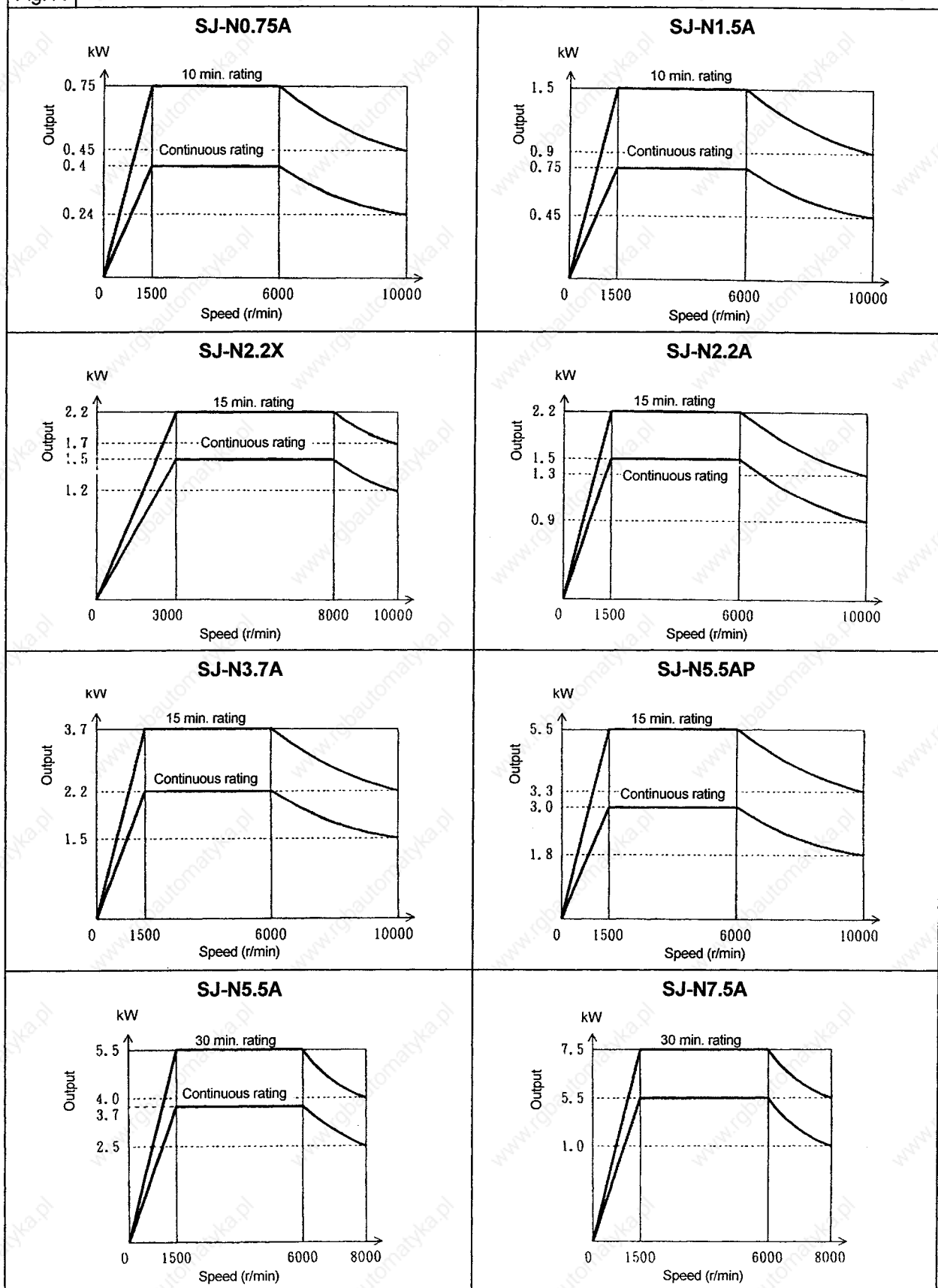

2. Specifications

2.3 Outline dimension drawings

2.3.1 Motor

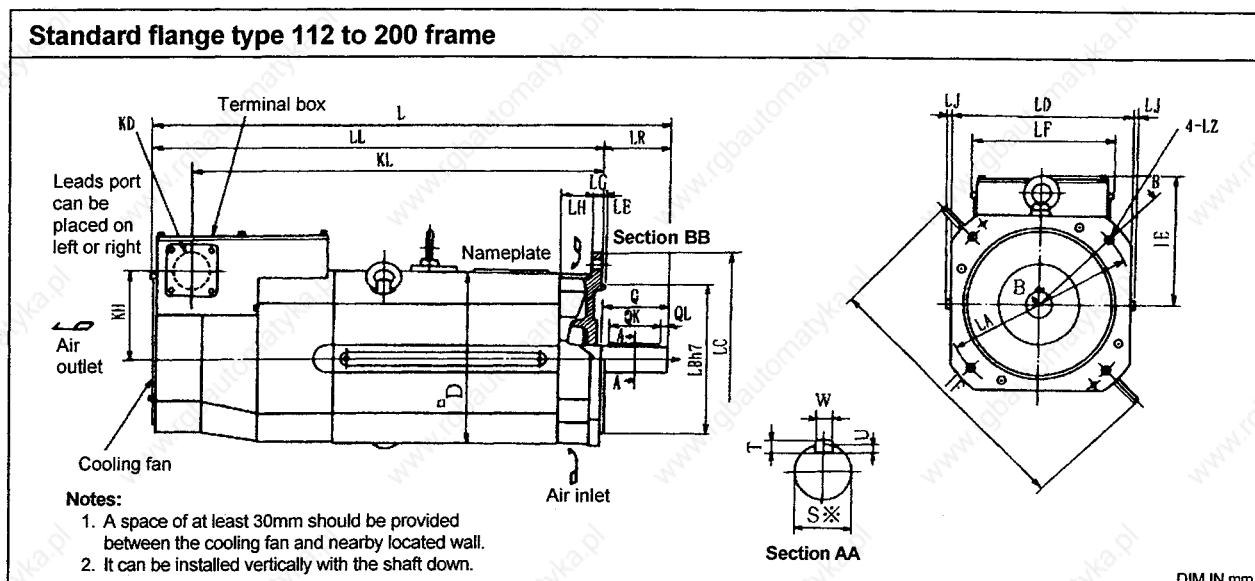

| Frame No. | Motor | | | | | | | | | | | | | | | | Shaft end | | | | | | | | | | |
|-----------|-------|-----|-----|----|-------|-----|-----|-----|-----|-----|----|-----|----|----|----|-----|-----------|-----|-----|-----|-----|----|----|-----|----|------|----|
| | D | L | IE | KD | KL | KH | LA | LB | LC | LD | LE | LF | LG | LH | LJ | LL | LZ | IF | LR | Q | QK | S | T | U | W | QL | ※ |
| A112F | 208 | 549 | 152 | 44 | 438 | 102 | 215 | 180 | 250 | 204 | 5 | 164 | 13 | 52 | 7 | 489 | 15 | 317 | 60 | 60 | 45 | 28 | 7 | 4 | 7 | 7.5 | h6 |
| B112F | 208 | 614 | 152 | 44 | 483 | 102 | 215 | 180 | 250 | 204 | 5 | 164 | 13 | 52 | 7 | 534 | 15 | 317 | 80 | 80 | 63 | 32 | 8 | 5 | 10 | 8 | h6 |
| B132F | 254 | 677 | 180 | 44 | 516 | 117 | 265 | 230 | 300 | 250 | 5 | 164 | 20 | 55 | 7 | 567 | 15 | 376 | 110 | 110 | 80 | 48 | 9 | 5.5 | 14 | 10 | h6 |
| C132F | 254 | 742 | 180 | 44 | 581 | 117 | 265 | 230 | 300 | 250 | 5 | 164 | 20 | 55 | 7 | 632 | 15 | 376 | 110 | 110 | 80 | 48 | 9 | 5.5 | 14 | 10 | h6 |
| A160F | 314 | 785 | 206 | 51 | 600.5 | 133 | 300 | 250 | 350 | 310 | 5 | 189 | 20 | 60 | 7 | 675 | 19 | 438 | 110 | 110 | 90 | 55 | 10 | 6 | 16 | 10.5 | m6 |
| B160F | 314 | 850 | 206 | 51 | 665.5 | 133 | 300 | 250 | 350 | 310 | 5 | 189 | 20 | 60 | 7 | 740 | 19 | 438 | 110 | 110 | 90 | 55 | 10 | 6 | 16 | 10.5 | m6 |
| B180F | 354 | 909 | 238 | 51 | 701.5 | 160 | 350 | 300 | 400 | 350 | 5 | 224 | 25 | 68 | 7 | 769 | 19 | 509 | 140 | 140 | 110 | 60 | 11 | 7 | 18 | 15 | m6 |
| A200F | 380 | 932 | 272 | 63 | 733 | 202 | 400 | 350 | 450 | 378 | 5 | 278 | 30 | 73 | 7 | 792 | 19 | 581 | 140 | 140 | 110 | 60 | 11 | 7 | 18 | 15 | m6 |

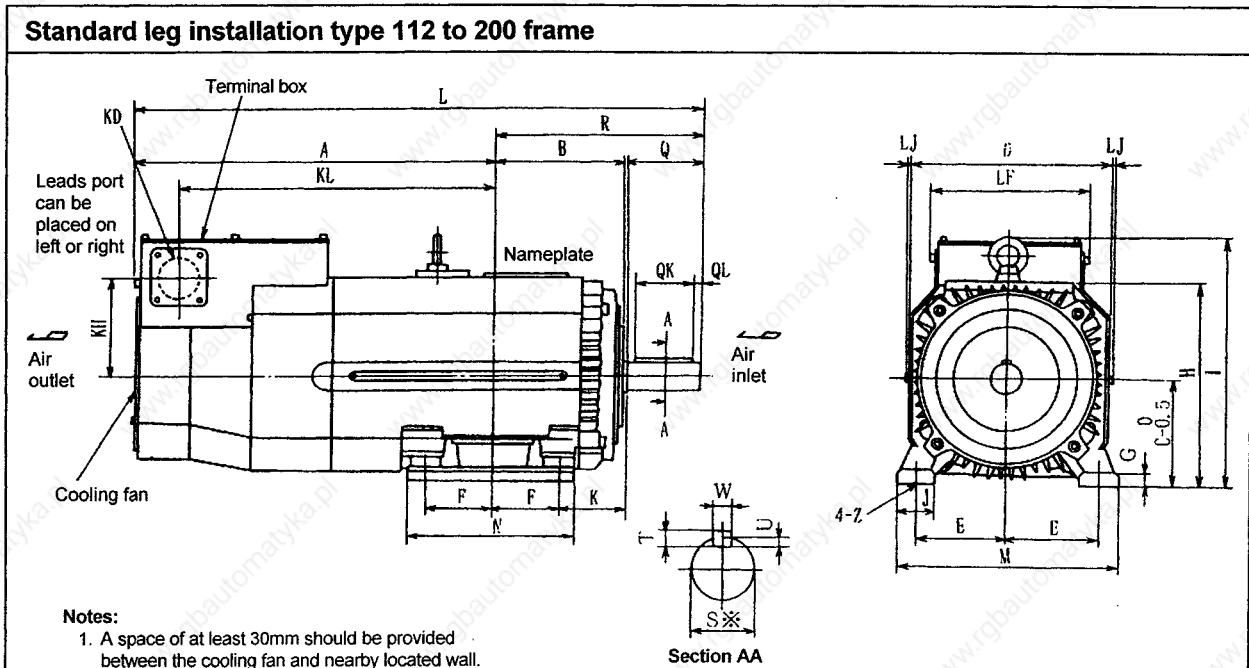

| Frame No. | Motor | | | | | | | | | | | | | | | | Shaft end | | | | | | | | | | | | |
|-----------|-------|-------|-----|-----|-------|-------|----|-----|-----|----|-----|----|-------|-----|-----|----|-----------|-----|-----|----|-----|-----|-------|----|----|-----|----|------|----|
| | A | B | C | D | E | F | G | H | I | J | K | KD | KL | KH | LF | LJ | L | M | N | Z | Q | QK | R | S | T | U | W | QL | ※ |
| A112M | 349 | 135 | 112 | 206 | 95 | 70 | 15 | 215 | 264 | 40 | 70 | 44 | 296 | 102 | 164 | 6 | 549 | 230 | 180 | 12 | 60 | 45 | 200 | 28 | 7 | 4 | 7 | 7.5 | h6 |
| B112M | 394 | 135 | 112 | 206 | 95 | 70 | 15 | 215 | 264 | 40 | 70 | 44 | 343 | 102 | 164 | 6 | 614 | 230 | 180 | 12 | 80 | 63 | 220 | 32 | 8 | 5 | 10 | 8 | h6 |
| B132M | 389 | 173 | 132 | 252 | 108 | 89 | 17 | 258 | 312 | 45 | 89 | 44 | 338 | 117 | 164 | 6 | 677 | 260 | 218 | 12 | 110 | 80 | 288 | 48 | 9 | 5.5 | 14 | 10 | h6 |
| C132L | 441.5 | 185.5 | 132 | 252 | 108 | 101.5 | 17 | 258 | 312 | 45 | 89 | 44 | 390.5 | 117 | 164 | 6 | 742 | 260 | 243 | 12 | 110 | 80 | 300.5 | 48 | 9 | 5.5 | 14 | 10 | h6 |
| A160L | 440 | 230 | 160 | 312 | 127 | 127 | 20 | 316 | 366 | 55 | 108 | 51 | 365.5 | 133 | 189 | 6 | 785 | 310 | 304 | 15 | 110 | 90 | 345 | 55 | 10 | 6 | 16 | 10.5 | m6 |
| B160L | 505 | 230 | 160 | 312 | 127 | 127 | 20 | 316 | 366 | 55 | 108 | 51 | 430.5 | 133 | 189 | 6 | 850 | 310 | 304 | 15 | 110 | 90 | 345 | 55 | 10 | 6 | 16 | 10.5 | m6 |
| B180L | 508.5 | 247.5 | 180 | 352 | 139.5 | 139.5 | 22 | 356 | 418 | 70 | 121 | 51 | 441 | 160 | 224 | 6 | 909 | 350 | 338 | 19 | 140 | 110 | 400.5 | 60 | 11 | 7 | 18 | 15 | m6 |
| A200L | 506.5 | 272.5 | 200 | 380 | 159 | 152.5 | 25 | 390 | 472 | 85 | 133 | 63 | 447.5 | 202 | 278 | 6 | 932 | 400 | 385 | 19 | 140 | 110 | 425.5 | 60 | 11 | 7 | 18 | 15 | m6 |

2. Specifications

Thin leg installation type

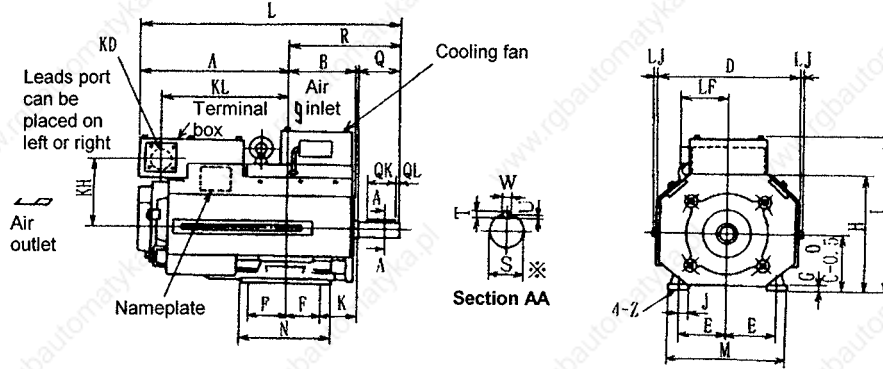

Notes:

1. A space of at least 30mm should be provided between the cooling fan and nearby located wall.

| Frame No. | Motor | | | | | | | | | | | | | | | | | Shaft end | | | | | | | | | | DIM IN mm | |
|-----------|-------|-------|-----|-----|-------|-------|----|-----|-----|----|-----|----|-------|-----|-----|----|-----|-----------|-----|----|-----|-----|-------|----|----|-----|----|-----------|----|
| | A | B | C | D | E | F | G | H | I | J | K | KD | KL | KH | LF | LJ | L | M | N | Z | Q | QK | R | S | T | U | W | | QL |
| B132MU | 312 | 173 | 132 | 320 | 108 | 89 | 17 | 304 | 371 | 45 | 89 | 44 | 262 | 170 | 95 | 6 | 600 | 260 | 218 | 12 | 110 | 80 | 288 | 48 | 9 | 5.5 | 14 | 10 | h6 |
| C132LU | 364.5 | 185.5 | 132 | 320 | 108 | 101.5 | 17 | 304 | 371 | 45 | 89 | 44 | 314.5 | 170 | 95 | 6 | 665 | 260 | 243 | 12 | 110 | 80 | 300.5 | 48 | 9 | 5.5 | 14 | 10 | h6 |
| A160LU | 322 | 230 | 160 | 356 | 127 | 127 | 20 | 348 | 446 | 55 | 108 | 51 | 272 | 195 | 118 | 6 | 667 | 310 | 304 | 15 | 110 | 90 | 345 | 55 | 10 | 6 | 16 | 10.5 | m6 |
| B160LU | 387 | 230 | 160 | 356 | 127 | 127 | 20 | 348 | 446 | 55 | 108 | 51 | 337 | 195 | 118 | 6 | 732 | 310 | 304 | 15 | 110 | 90 | 345 | 55 | 10 | 6 | 16 | 10.5 | m6 |
| B180LU | 399.5 | 255.5 | 180 | 400 | 139.5 | 139.5 | 22 | 397 | 495 | 70 | 121 | 51 | 349.5 | 222 | 118 | 6 | 800 | 350 | 338 | 19 | 140 | 110 | 400.5 | 60 | 11 | 7 | 18 | 15 | m6 |

High-speed 1000rpm

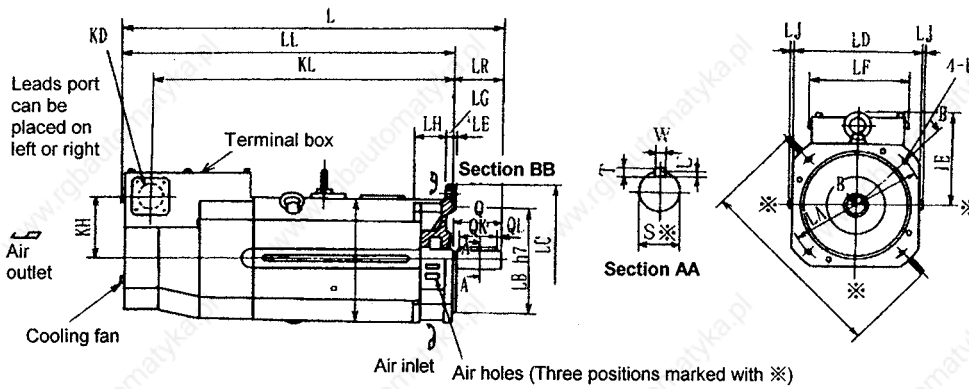

Notes:

1. A space of at least 30mm should be provided between the cooling fan and nearby located wall.
2. It can be installed vertically with the shaft down.
3. When horizontal installation of the shaft is used, install so that the air holes face the left, right and bottom sides.

| Frame No. | Motor | | | | | | | | | | | | | | | | | Shaft end | | | | | | | | | | DIM IN mm |
|-----------|-------|-----|-----|----|-----|-----|-----|-----|-----|-----|----|-----|----|----|----|-----|----|-----------|----|----|----|----|---|---|---|-----|----|-----------|
| | D | L | IE | KD | KL | KH | LA | LB | LC | LD | LE | LF | LG | LH | LJ | LL | LZ | IF | LR | Q | QK | S | T | U | W | QL | ※ | |
| A112F | 208 | 549 | 152 | 44 | 438 | 102 | 215 | 180 | 250 | 204 | 5 | 164 | 13 | 52 | 7 | 489 | 15 | 317 | 60 | 60 | 45 | 28 | 7 | 4 | 7 | 7.5 | h6 | |
| B112F | 208 | 549 | 152 | 44 | 483 | 102 | 215 | 180 | 250 | 204 | 5 | 164 | 13 | 52 | 7 | 534 | 15 | 317 | 60 | 60 | 45 | 28 | 7 | 4 | 7 | 7.5 | h6 | |

2. Specifications

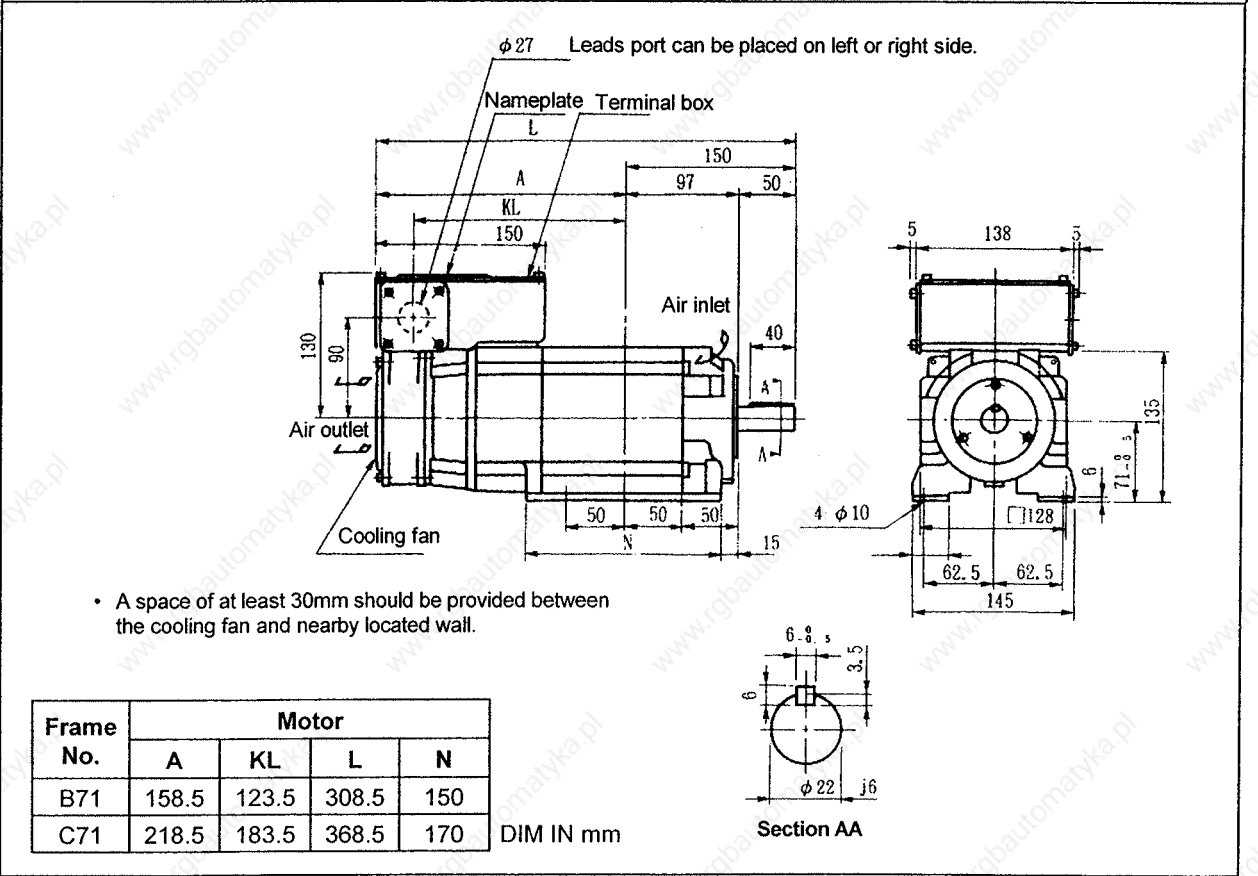
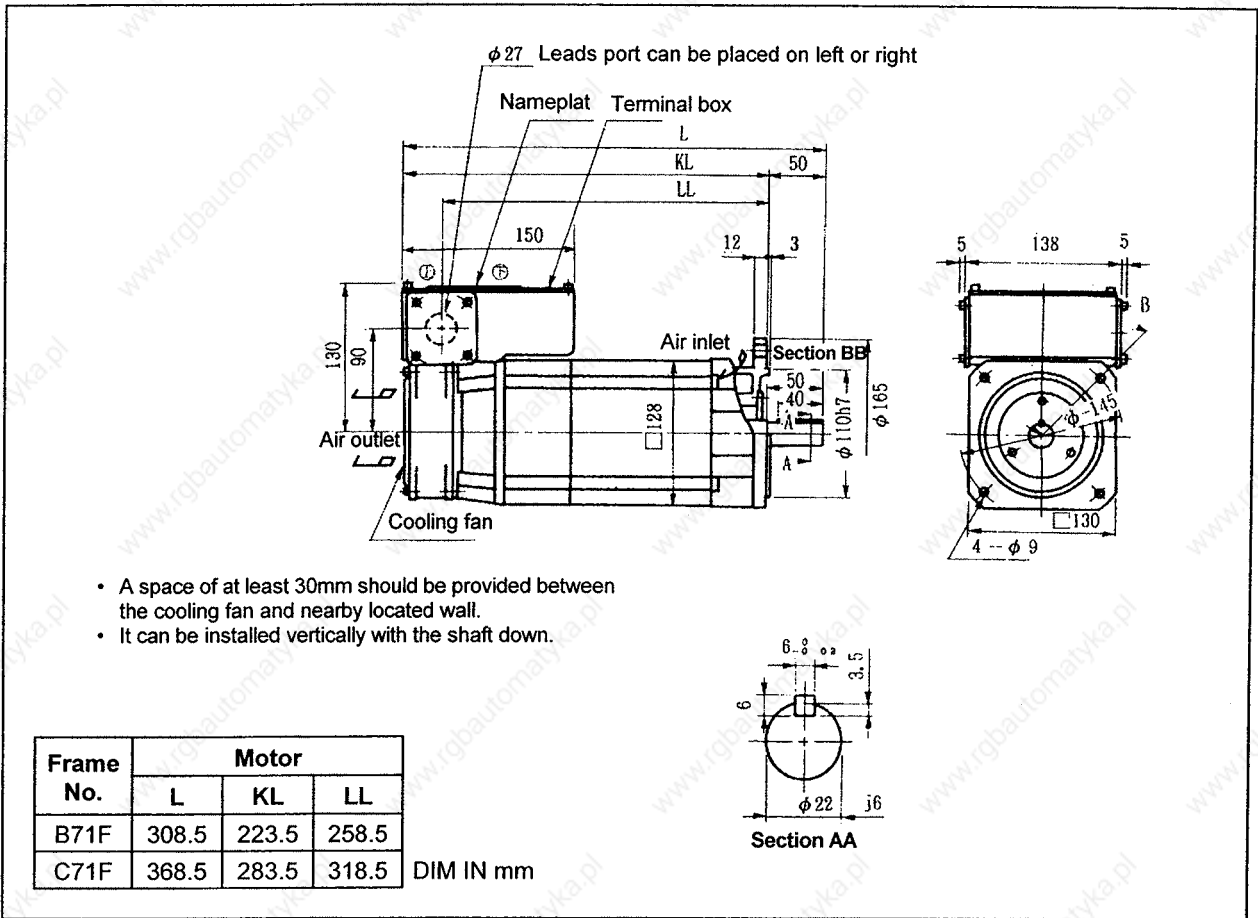

2. Specifications

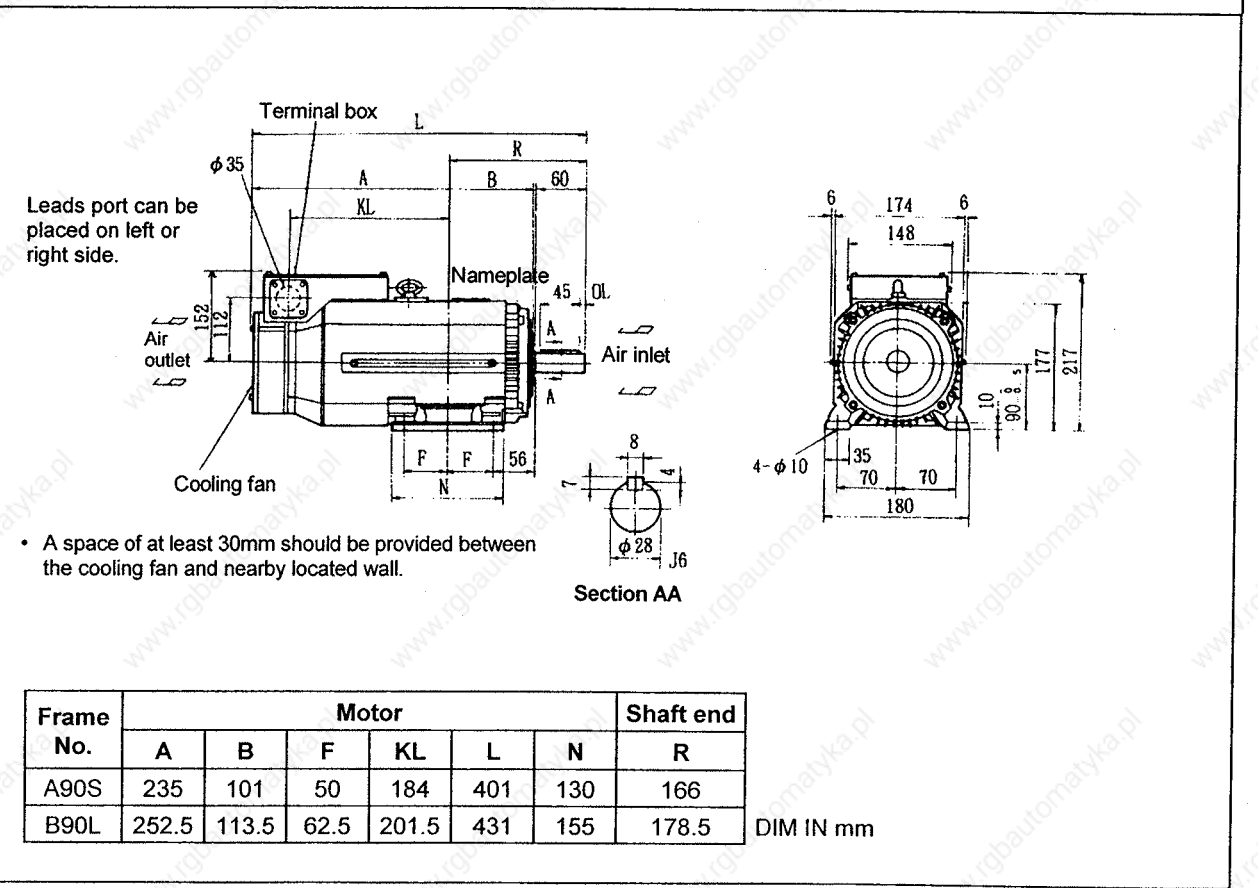
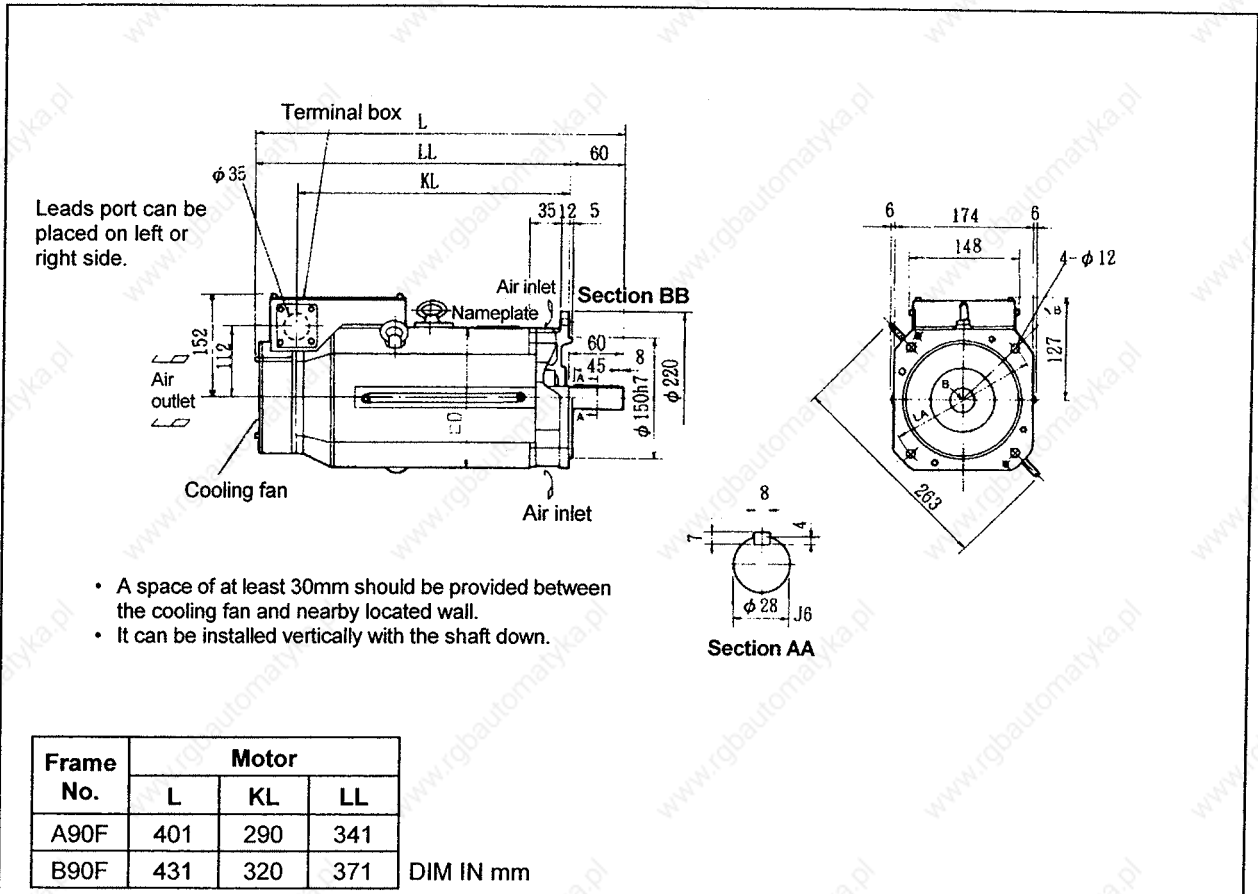

2. Specifications

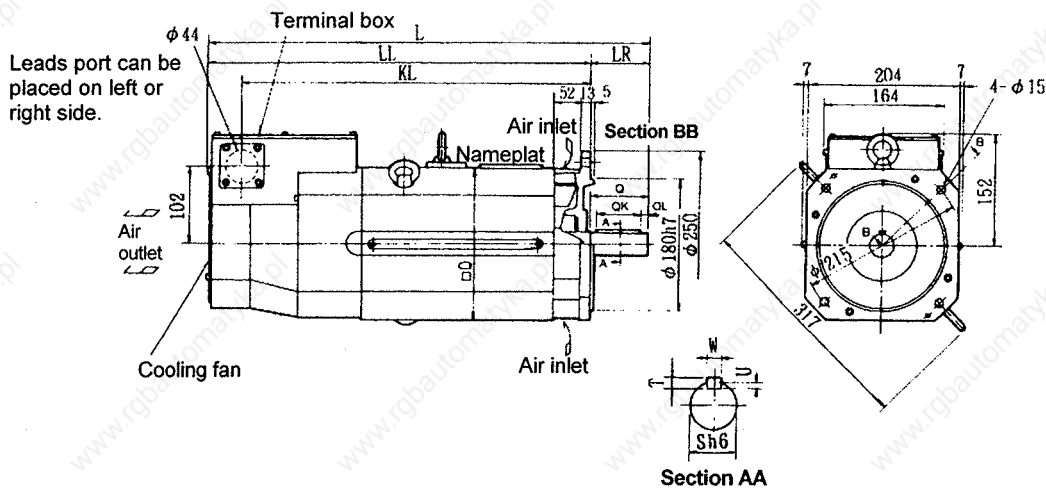

- A space of at least 30mm should be provided between the cooling fan and nearby located wall.
- It can be installed vertically with the shaft down.

| Frame No. | Motor | | | Shaft end | | | | | | | | DIM IN mm |
|-----------|-------|-----|-----|-----------|----|----|----|---|---|----|-----|-----------|
| | L | KL | LL | LR | Q | QK | S | T | U | W | QL | |
| A112F | 549 | 438 | 489 | 60 | 60 | 45 | 28 | 7 | 4 | 7 | 7.5 | |
| B112F | 614 | 483 | 534 | 80 | 80 | 63 | 32 | 8 | 5 | 10 | 8 | |

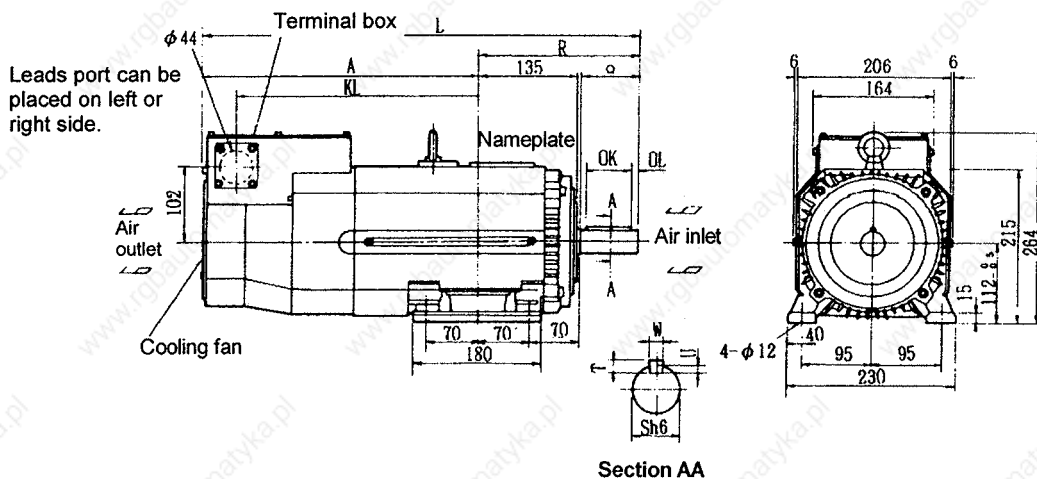

- A space of at least 30mm should be provided between the cooling fan and nearby located wall.

| Frame No. | Motor | | | Shaft end | | | | | | | | DIM IN mm |
|-----------|-------|-----|-----|-----------|----|-----|----|---|---|----|-----|-----------|
| | A | KL | L | Q | QK | R | S | T | U | W | QL | |
| A112M | 349 | 298 | 549 | 60 | 45 | 200 | 28 | 7 | 4 | 7 | 7.5 | |
| B112M | 394 | 343 | 614 | 80 | 63 | 220 | 32 | 8 | 5 | 10 | 8 | |

2. Specifications

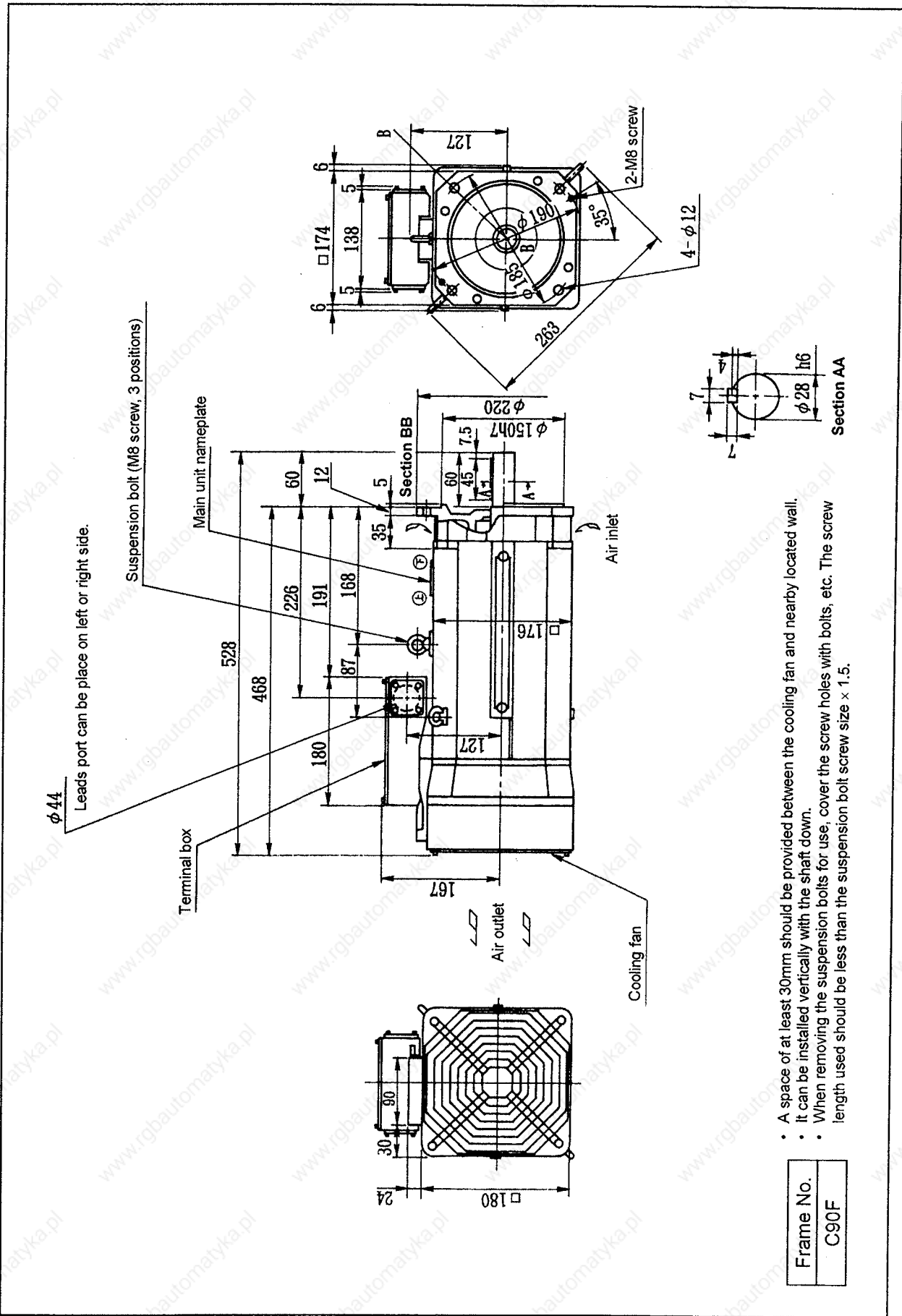

- A space of at least 30mm should be provided between the cooling fan and nearby located wall.
- it can be installed vertically with the shaft down.
- When removing the suspension bolts for use, cover the screw holes with bolts, etc. The screw length used should be less than the suspension bolt screw size x 1.5.

| |
|-----------|
| Frame No. |
| C90F |

3. Functions

3.1 Control input signals

(1) Speed command input

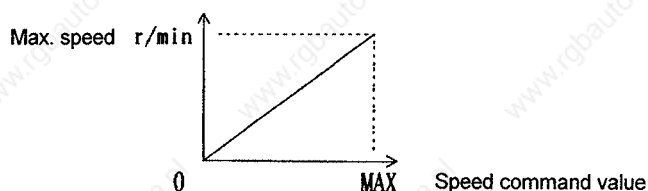

- 1) When the speed command value is 0, the motor speed will be 0; and when the speed command value is the maximum value, the motor speed will be the maximum motor speed set in parameter SP017 (TSP).
- 2) The motor will forward run and reverse run with the forward run and reverse run start commands. (The motor will not rotate with only the speed command value.)

(2) Forward run start command (SRN)

- 1) When SRN is ON, the motor will run in the counterclockwise direction (CCW) looking from the shaft side according to the commanded speed.
- 2) When SRN is OFF, the motor will decelerate to a stop, the transistor base will shut off and the motor will stop.
- 3) The orientation movement will be a priority when the orientation command is input.

(3) Reverse run start command (SRI)

- 1) When SRI is ON, the motor will run in the counterclockwise direction (CCW) looking from the shaft side according to the commanded speed.
- 2) When SRI is OFF, the motor will decelerate to a stop, the transistor base will shut off and the motor will stop.
- 3) The orientation movement will be a priority when the orientation command is input.

(4) Torque limit 1, 2, 3 input (TL1, TL2, TL3)

- 1) The torque limit will temporarily reduce the motor output torqued during mechanical spindle orientation or gear shift, etc., and will rotate the motor.
- 2) The following seven torque limit values can be used according to the combination of the TL1, TL2 and TL3 bit inputs.

| TL3 | TL2 | TL1 | Torque limit value |
|-----|-----|-----|---|
| 0 | 0 | 1 | Torque limit value (%) set with parameter SP021 |
| 0 | 1 | 0 | SP049 |
| 0 | 1 | 1 | SP050 |
| 1 | 0 | 0 | SP051 |
| 1 | 0 | 1 | SP052 |
| 1 | 1 | 0 | SP053 |
| 1 | 1 | 1 | SP054 |

(Note) % indicates the percentage to the motor 30 min. rated torque.

3. Functions

(5) Orientation start command input (ORC)

- 1) This is the orientation movement start signal. When ORC is ON, the orientation will start regardless of the operation command (SRN, SRI).
- 2) When ORC is OFF, the motor will start rotating at the commanded speed again if either forward run (SRN) or reverse run (SRI) are input.
- 3) The orientation movement will be a priority when the orientation command is input.

(6) Gear selection command 1, 2, 3 input (GR1, GR2, GR3)

- 1) The spindle gear step for orientation movement or various position control movements is selected.
- 2) The following eight gear steps can be selected according to the combination of the GR1, GR2 and GR3 3bit inputs.
- 3) Do not change the signal while the orientation command or servo ON command is input.

| GR3 | GR2 | GR1 | Parameters used to set the gear ratio |
|-----|-----|-----|---------------------------------------|
| 0 | 0 | 0 | SP025 (GRA1), SP029 (GRB1) |
| 0 | 0 | 1 | SP026 (GRA2), SP030 (GRB2) |
| 0 | 1 | 0 | SP027 (GRA3), SP031 (GRB3) |
| 0 | 1 | 1 | SP028 (GRA4), SP032 (GRB4) |
| 1 | 0 | 0 | SP225 (GRA5), SP229 (GRB5) |
| 1 | 0 | 1 | SP226 (GRA6), SP230 (GRB6) |
| 1 | 1 | 0 | SP227 (GRA7), SP231 (GRB7) |
| 1 | 1 | 1 | SP228 (GRA8), SP232 (GRB8) |

(7) Index forward run command input (WRN), reverse run command input (WRI)

- 1) This is the command input for forward run index or reverse run index during multipoint orientation.
- 2) The forward run index will start from the CCW direction looking from the motor shaft end and the reverse run index will start from the CW direction.

(8) L coil selection command input (LCS)

- 1) This is the command input signal for selecting the low-speed coil or high-speed coil when changing the coils.
- 2) The high-speed coil is selected when LCS is OFF, and the low-speed coil is selected when LCS is ON.

(9) Sub-motor selection command input (MS)

- 1) This is the command input signal for selecting the main motor or sub-motor when changing during the 1-amplifier 2-motor specifications.
- 2) The main motor is selected when MS is OFF, and the sub-motor is selected when LCS is OFF.

(10) Cutting input (G1)

This signal determines whether cutting is being performed during C-axis control. The operation will be determined as cutting when G1 is ON.

3. Functions

(11) Control mode selection command 1, 2, 3, 4, 5 input (SC1, SC2, SC3, SC4, SC5)

The operation mode during spindle drive unit position control is selected with the bits. The selections shown below are used.

| SC5 | SC4 | SC3 | SC2 | SC1 | Operation mode |
|-----|-----|-----|-----|-----|------------------------------------|
| 0 | 1 | 0 | 0 | 0 | Synchronous tap operation mode |
| 0 | 1 | 0 | 1 | 1 | |
| 0 | 1 | 1 | 0 | 0 | C-axis operation mode |
| 0 | 1 | 1 | 1 | 1 | |
| 1 | 0 | 0 | 0 | 0 | Spindle synchronous operation mode |
| 1 | 0 | 0 | 1 | 1 | |

(Note) The normal speed operation mode will be entered when bits other than the above are selected.

3. Functions

3.2 Control output signals

(1) Zero speed output signal (ZS)

- 1) ZS turns ON if the actual motor speed drops below the zero speed detection point in regard to the stop command.
- 2) The signal is output whether run command signal is SRN (forward run) or SRI (reverse run).
- 3) The minimum output pulse width is about 200ms.
- 4) The zero speed detection speed is set with parameter SP018 (ZSP) in the range of 0 to 1000min^{-1} .

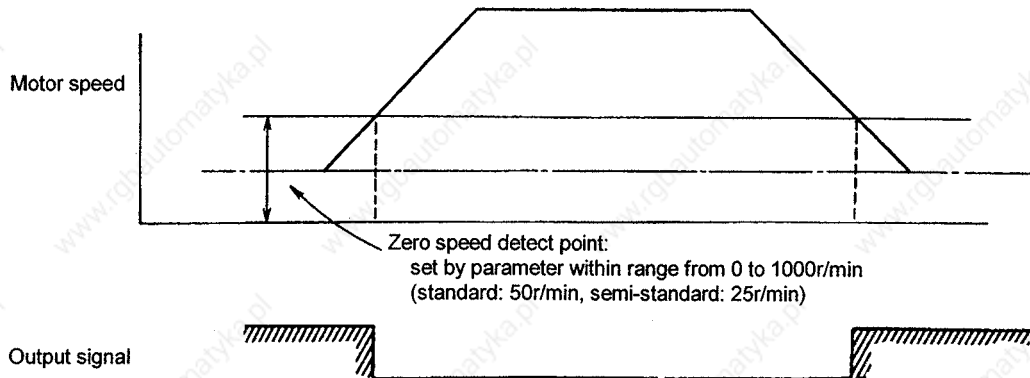

(2) Up-to-speed output signal (US)

- 1) USO turns ON when the actual motor speed reaches $\pm 15\%$ of the commanded speed.

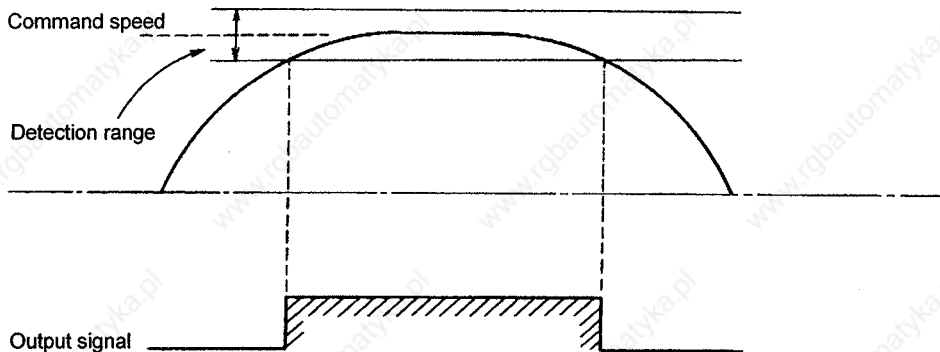

- 2) This signal is not output unless either SRN or SRI turns on.
- 3) The signal can be used to verify implementation of "forward run (M03)" or "reverse run (M04)" command.
- 4) If the reverse run command turns ON, the motor will start to deceleration. The USO signal will turn OFF, and after confirming that the reached signal turns ON, the reverse command will be completed.

3. Functions

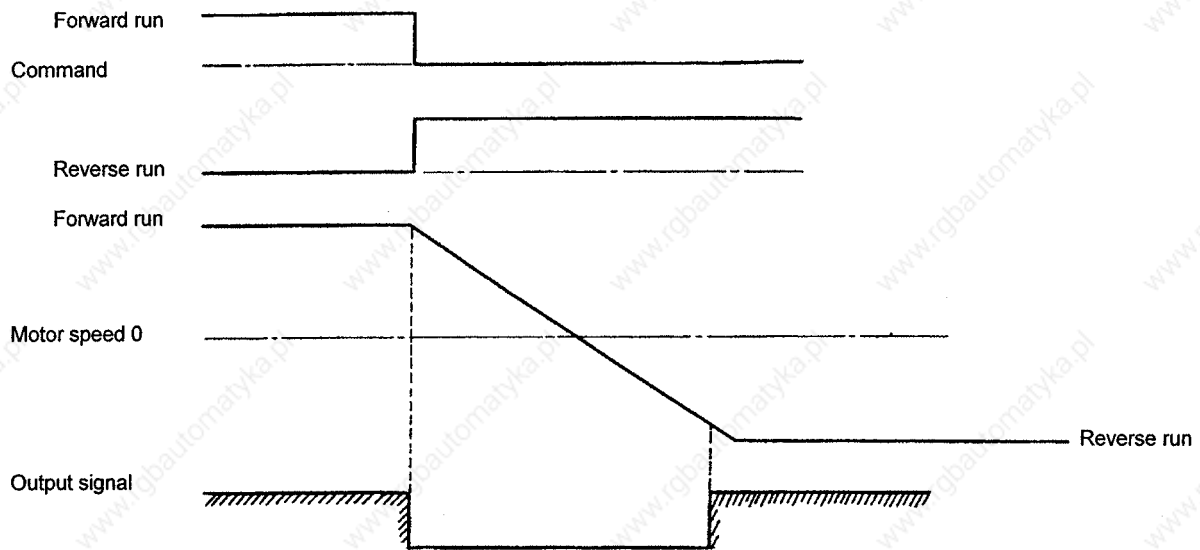

(3) Speed detection output (SD)

- 1) SDT turns ON when the speed drops below the speed set in parameter SP020 (SDTS).
- 2) The SDT signal will turn ON when the motor speed's absolute value drops below the set detection level regardless of the run command (SRN, SRI).

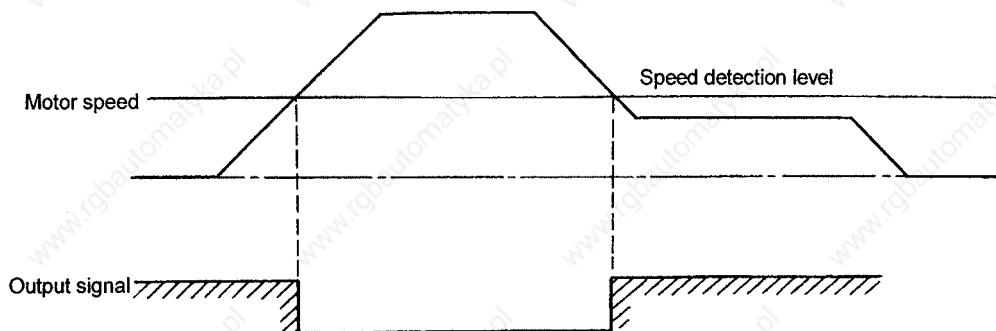

(4) Orientation complete output (ORCF)

ORCF will turn ON when the spindle position is currently within the in-position range set with parameter SP004 (OINP) during orientation.

(5) Current detect output (CD)

CD will turn ON when the current value is 110% or more than the rated current.

(6) Forward run starting command output (SRNA)

This is the answer output to the forward run start command input (SRN).

(7) Reverse run starting command output (SRIA)

This is the answer output to the reverse run start command input (SRI).

(8) Torque limiting 1, 2, 3 input (TL1A, TL2A, TL3A)

This is the answer output to the torque limit 1, 2, 3 input (TL1, TL2, TL3).

(9) Orientation starting command output (ORCA)

This is the answer output to the orientation start command input (ORC).

3. Functions

(10) Gear selecting command 1, 2, 3 output (GR1A, GR2A, GR3A)

This is the answer output to the gear selection command 1, 2, 3 input (GR1, GR2, GR3).

(11) Index forward run command output (WRNA), reverse run command output (WRIA)

This is the answer output to the index forward run command (WRN) and reverse run command (WRI).

(12) L coil selection command output (LCSA)

This is the answer output to the L coil selection command input (LCS).

(13) Sub-motor selection command output (MSA)

This is the answer output to the sub-motor selection command (MS).

(14) Synchronous speed match output (SYSA)

SYSA turns ON when the movement from the speed operation mode to the spindle synchronous operation mode is possible during spindle synchronous operation.

(15) Coil changeover output (MKC)

MKC turns ON for a set time when changing over from the L coil to the H coil or the H coil to the L coil during coil changeover.

(16) Index positioning complete output (WRCF)

WRCF turns ON when indexing is completed.

(17) Drive unit warning output (WRN)

WRN turns ON when any warning occurs in the spindle drive unit.

(18) Alarm output (ALM)

ALM turns ON when any alarm occurs in the spindle drive unit.

(19) Z-phase passed output (ZFIN)

ZFIN turns ON when the Z-phase is passed for the first time after the servo turns ON during position control.

(20) Position loop in-position output (INP)

INP turns ON when the current position is within the in-position range set with parameters during positioning other than orientation. INP turns OFF when the servo turns OFF.

(21) Control mode selection command 1, 2, 3, 4, 5 output (SC1A, SC2A, SC3A, SC4A, SC5A)

This is the answer output to the control mode selection command 1, 2, 3, 4, 5 input (SC1, SC2, SC3, SC4, SC5).

3. Functions

3.3 Meter outputs

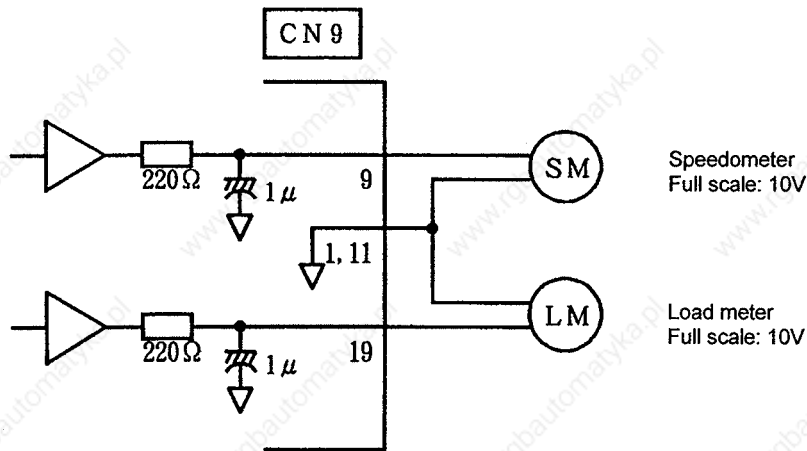

(1) Speedometer output

(a) The following meter is recommended for speedometer.

- 1) Model : YM-8G DC voltmeter (Mitsubishi)
- 2) Rating : 10VDC full scale
- 3) Internal impedance : About 10k Ω

(b) When motor runs at the max. speed, +10VDC is output, no matter of direction of rotation.

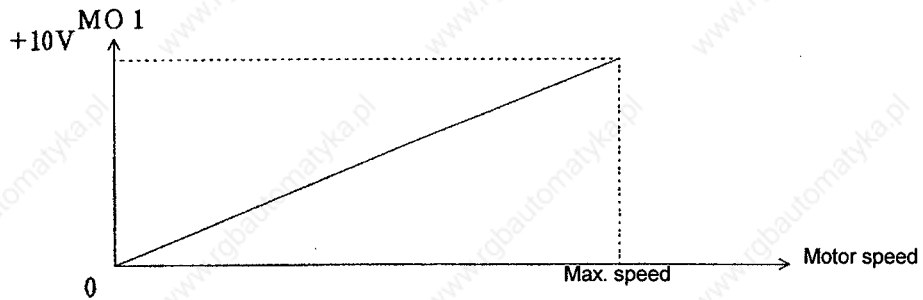

(2) Load meter output

(a) The following meter is recommended for load meter.

- 1) Model : YM-8G DC voltmeter (Mitsubishi)
- 2) Rating : 10VDC full scale
- 3) Internal impedance : About 10k Ω
- 4) Scale

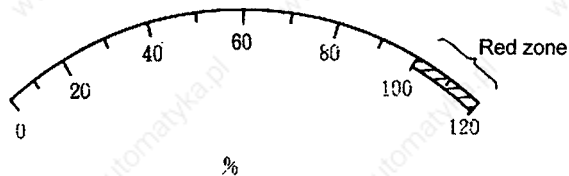

3. Functions

(b) Reading of load meter is percent (%) of load to the rated motor output. The relationship between motor kW and load meter reading is as follows:

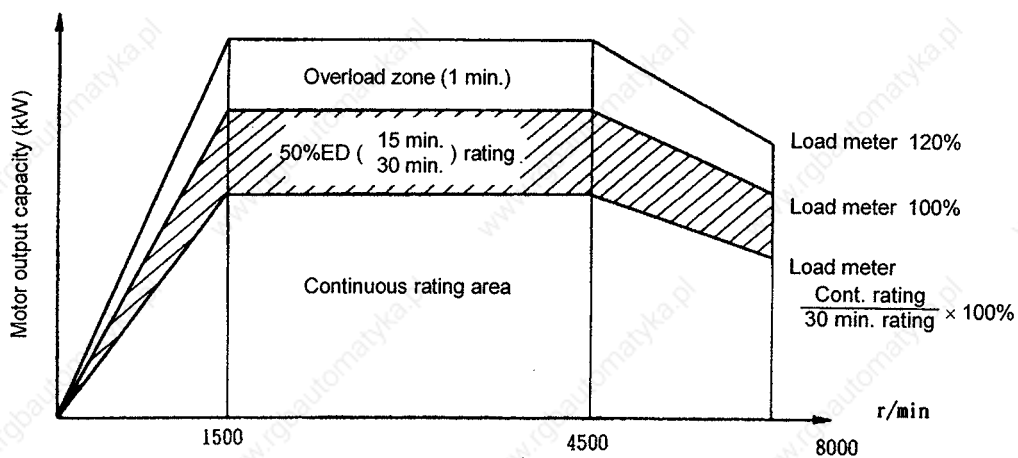

3. Functions

3.4 Output interface

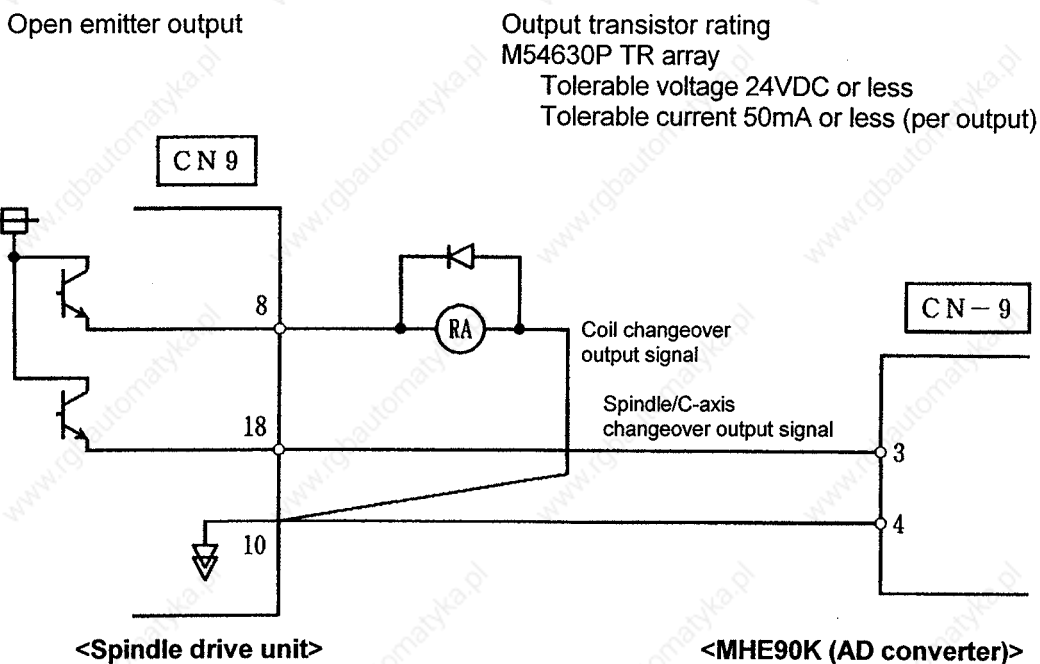

- (Note 1) Connect the spindle/C-axis changeover output signal only when using the MHE90K detector.
 (Note 2) The changeover circuit configuration for coil changeover is as shown below.

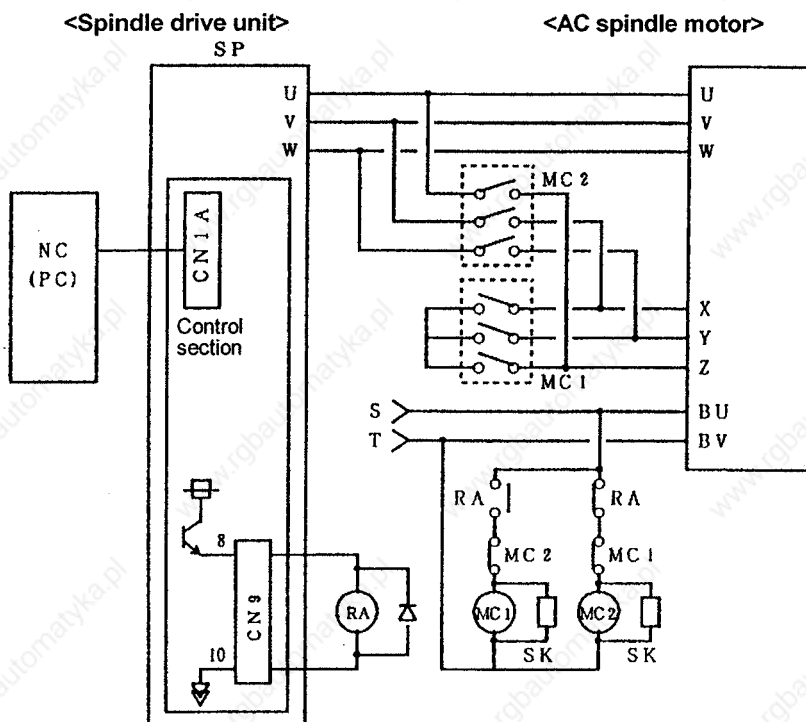

- The relays, contactors, cables, etc., for the spindle drive unit and AC spindle motor that are not enclosed in the bold line must be prepared by the machine maker.
 - The relay (RA) must be connected in parallel with the flywheel diode; and the contactors (MC1, MC2) must be connected in parallel with the CR surge absorber coil.
- * During low-speed coil selection..... ∧ connection (Turn MC1 ON, MC2 OFF)
 During high-speed coil selection..... △ connection (Turn MC1 OFF, MC2 ON)

4. Status Display and Parameter Settings

4. Status Display and Parameter Settings

⚠ WARNING

1. Do not operate the switches with wet hands. Failure to observe this could lead to electric shocks.
2. Do not operate the unit with the front cover removed. The high voltage terminals and charged sections will be exposed, and could lead to electric shocks.
3. Do not open the front cover while the power is ON or during operation. Failure to observe this could lead to electric shocks.

⚠ CAUTION

1. Check the parameters before starting operation. Failure to do so could lead to unforeseen movements of the machine.
2. Do not touch the servo amplifier heat radiating fins, regenerative resistor or servomotor, etc., while the power is turned ON or immediately after turning the power OFF. Some parts are heated to high temperatures, and touching these could lead to burns.

4.1 Status display with 7-segment LED

The status can be displayed on the 7-segment LED on the power supply and spindle drives when the power is turned on.

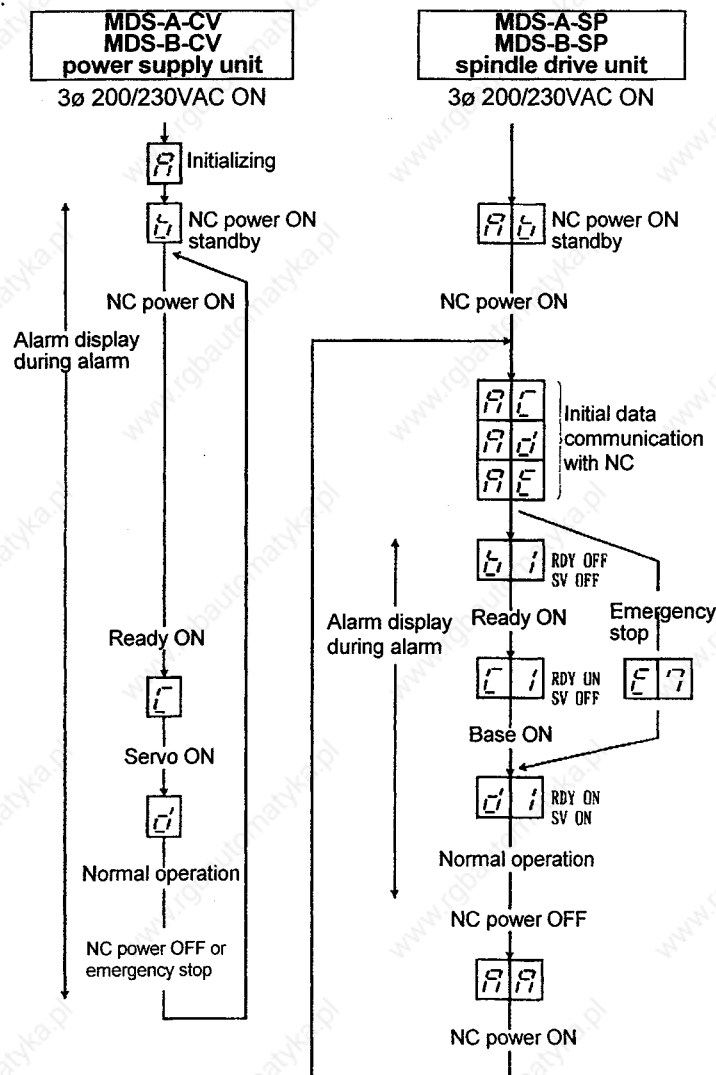

The right segment of **h l** **l l** **d l** indicates the axis NO.
(This example shows the 1st axis.)

4. Status Display and Parameter Settings

4.2 Spindle parameters

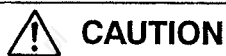

Do not make remarkable adjustments or changes of the parameters as the operation may become unstable.

(1) Parameter list

(Note 1) All spindle parameters (total of 384) can be set from the M500 CNC screen in the MDS-A-SP (MDS-B-SP).

(Note 2) Parameters marked with a * in the CNG column can be set and changed without turning off the NC power.

(Note 3) If the MDS-A-SP software version is A1 and above, the lower limit of the SP033 to SP384 tolerable setting range will all be changed to 0.

| Class | No. | Abbr. | Name | Description | TYP | CNG | Standard setting | Unit | Tolerable setting range |
|------------------------|--------------|-------|--|---|-----|-----|------------------|---------------------|-------------------------|
| Spindle specifications | SP001 | PGM | Magnesensor, motor built-in encoder orientation position loop gain | The orientation time will be reduced when the value is increased and the servo rigidity will increase. On the other hand, the vibration will increase and machine sway will occur easily. | DEC | * | 100 | 1/10rad/sec (1/sec) | 0 ~ 360 |
| | SP002 | PGE | Encoder orientation position loop gain | Same as above. | DEC | * | 100 | 1/10rad/sec (1/sec) | 0 ~ 360 |
| | SP003 | PGCO | C-axis non-cutting time position loop gain | The position loop gain during C-axis non-cutting is set. | DEC | * | 15 | rad/sec (1/sec) | 0 ~ 100 |
| | SP004 | OINP | Orientation in-position width | The position error range where the orient complete signal is output is set. | DEC | * | 16 | 1/16 deg. | 1 ~ 2880 |
| | SP005 | OSP | Orientation changeover speed limit value | The motor speed limit value for when changing from the speed loop to position loop during orientation is set. When the setting value is 0, the limit value will be SP017 (TSP). | DEC | | 0 | r/min | 0 ~ 32767 |
| | SP006 | CSP | Deceleration rate during orientation | The orientation time will be reduced when the value is increased, but the vibration will increase. | DEC | * | 20 | | 1 ~ 1000 |
| | SP007 | OPST | Orientation position shift amount | The orientation stop position is set. ① Motor built-in encoder, encoder: Set a value that is 360° divided by 4096. ② Magnesensor: Divide -5° to +5° by 1024, and set 0° as 0. | DEC | * | 0 | | ① 0-4095 ② -512-512 |
| | SP008 | | | Not used. Set to 0. | DEC | | 0 | | ~ |
| | SP009 | PGT | Synchronous tap position loop gain | The spindle position loop gain during synchronous tap is set. | DEC | * | 15 | rad/sec (1/sec) | 1 ~ 100 |
| | SP010 | PGS | Spindle synchronization position loop gain | The spindle position loop gain during spindle synchronization is set. | DEC | * | 15 | rad/sec (1/sec) | 1 ~ 100 |
| | SP011 ~ SP16 | | | Not used. Set to 0. | DEC | | 0 | | ~ |
| | SP017 | TSP | Motor max. speed | The motor's maximum speed is set. | DEC | | 6000 | r/min | 1 ~ 32767 |
| | SP018 | ZSP | Motor zero speed | The motor speed where zero speed is output is set. | DEC | | 50 | r/min | 1 ~ 1000 |
| | SP019 | CSN1 | Speed command Acceleration/deceleration time constant | The time constant for the speed command from 0 to the maximum speed is set. (This is invalid during position loop.) | DEC | | 30 | 10 ms | 1 ~ 32767 |
| | SP020 | SDTS | Speed detection set value | The motor speed where the speed detection output is performed is set. Normally, 10% of the SP017 (TSP) value is set. | DEC | | 600 | r/min | 1 ~ 32767 |
| | SP021 | TLM1 | Torque limit 1 | The torque limit ratio for when torque limit signal 001 is set. | DEC | | 10 | % | 1 ~ 120 |
| | SP022 | VGNP1 | Speed loop gain proportion item during speed control | The speed loop proportional gain during speed control is set. The response will improve when increased, but vibration and sound will increase. | DEC | | 63 | rad/s | 0 ~ 1000 |
| | SP023 | VGN11 | Speed loop gain integral item during speed control | The speed loop integral gain during speed control is set. Normally, this is set so that the percentage to SP022 (VGNP1) is approximately constant. | DEC | | 60 | 1/10 rad/s | 0 ~ 1000 |
| | SP024 | | | Not used. Set to 0. | DEC | | 0 | | ~ |
| | SP025 | GRA1 | Spindle side No. of gear teeth 1 | The No. of teeth on the spindle side is set for gear 000. | DEC | | 1 | | 1 ~ 32767 |
| | SP026 | GRA2 | Spindle side No. of gear teeth 2 | The No. of teeth on the spindle side is set for gear 001. | DEC | | 1 | | 1 ~ 32767 |
| | SP027 | GRA3 | Spindle side No. of gear teeth 3 | The No. of teeth on the spindle side is set for gear 010. | DEC | | 1 | | 1 ~ 32767 |
| | SP028 | GRA4 | Spindle side No. of gear teeth 4 | The No. of teeth on the spindle side is set for gear 011. | DEC | | 1 | | 1 ~ 32767 |
| | SP029 | GRB1 | Motor shaft side No. of gear teeth 1 | The No. of teeth on the motor shaft side is set for gear 000. | DEC | | 1 | | 1 ~ 32767 |

4. Status Display and Parameter Settings

| Class | No. | Abbr. | Name | Description | TYP | CNG | Standard setting | Unit | Tolerable setting range | | | | | | | | | | | | | | | | | | | | | | | | | | | | | | | | | | | | |
|--------------------------------|-------------------|--|---|---|-------------------|--------------------------------|-------------------|----------------|-------------------------|---|------|--------|------|--------|------|--------|------|-------|------|--------|------|-------|------|--------|------|-------|------|--------|------|-------|------|---------|------|-------|------|---------|------|--------|------|-------|-----|--|------|--|-------------|
| Spindle/machine specifications | SP030 | GRB2 | Motor shaft side No. of gear teeth 2 | The No. of teeth on the motor shaft side is set for gear 001. | DEC | | 1 | | 1 ~ 32767 | | | | | | | | | | | | | | | | | | | | | | | | | | | | | | | | | | | | |
| | SP031 | GRB3 | Motor shaft side No. of gear teeth 3 | The No. of teeth on the motor shaft side is set for gear 010. | DEC | | 1 | | 1 ~ 32767 | | | | | | | | | | | | | | | | | | | | | | | | | | | | | | | | | | | | |
| | SP032 | GRB4 | Motor shaft side No. of gear teeth 4 | The No. of teeth on the motor shaft side is set for gear 011. | DEC | | 1 | | 1 ~ 32767 | | | | | | | | | | | | | | | | | | | | | | | | | | | | | | | | | | | | |
| | SP033 | SFNC1 | Spindle function 1 | This corresponds to bits, and sets the spindle function 1 selection. Refer to section 4.2.(2) for details. | HEX | | 0000 | | 0000 ~ FFFF | | | | | | | | | | | | | | | | | | | | | | | | | | | | | | | | | | | | |
| | SP034 | SFNC2 | Spindle function 2 | This corresponds to bits, and sets the spindle function 1 selection. Refer to section 4.2.(2) for details. | HEX | | 0000 | | 0000 ~ FFFF | | | | | | | | | | | | | | | | | | | | | | | | | | | | | | | | | | | | |
| | SP035 | SFNC3 | Spindle function 3 | This corresponds to bits, and sets the spindle function 1 selection. Refer to section 4.2.(2) for details. | HEX | | 0000 | | 0000 ~ FFFF | | | | | | | | | | | | | | | | | | | | | | | | | | | | | | | | | | | | |
| | SP036 | SFNC4 | Spindle function 4 | This corresponds to bits, and sets the spindle function 1 selection. Refer to section 4.2.(2) for details. | HEX | | 0000 | | 0000 ~ FFFF | | | | | | | | | | | | | | | | | | | | | | | | | | | | | | | | | | | | |
| | SP037 | SFNC5 | Spindle function 5 | This corresponds to bits, and sets the spindle function 1 selection. Refer to section 4.2.(2) for details. | HEX | | 0000 | | 0000 ~ FFFF | | | | | | | | | | | | | | | | | | | | | | | | | | | | | | | | | | | | |
| | SP038 | SFNC6 | Spindle function 6 | This corresponds to bits, and sets the spindle function 1 selection. Refer to section 4.2.(2) for details. | HEX | | 0000 | | 0000 ~ FFFF | | | | | | | | | | | | | | | | | | | | | | | | | | | | | | | | | | | | |
| | SP039 | ATYP | Amplifier type | The amplifier type is set. Set each amplifier type or 0. This corresponds to MDS-A-SP (Version A2 and above), and MDS-B-SP. <table border="1" style="margin: 5px auto; border-collapse: collapse;"> <thead> <tr> <th>Parameter setting</th> <th>Amplifier type</th> <th>Parameter setting</th> <th>Amplifier type</th> </tr> </thead> <tbody> <tr><td>0000</td><td>—</td><td>0008</td><td>SP-150</td></tr> <tr><td>0001</td><td>SP-075</td><td>0009</td><td>SP-185</td></tr> <tr><td>0002</td><td>SP-15</td><td>000A</td><td>SP-220</td></tr> <tr><td>0003</td><td>SP-22</td><td>000B</td><td>SP-260</td></tr> <tr><td>0004</td><td>SP-37</td><td>000C</td><td>SP-300</td></tr> <tr><td>0005</td><td>SP-55</td><td>000D</td><td>CSP-370</td></tr> <tr><td>0006</td><td>SP-75</td><td>000E</td><td>CSP-450</td></tr> <tr><td>0007</td><td>SP-110</td><td>000F</td><td>SP-04</td></tr> </tbody> </table> | Parameter setting | Amplifier type | Parameter setting | Amplifier type | 0000 | — | 0008 | SP-150 | 0001 | SP-075 | 0009 | SP-185 | 0002 | SP-15 | 000A | SP-220 | 0003 | SP-22 | 000B | SP-260 | 0004 | SP-37 | 000C | SP-300 | 0005 | SP-55 | 000D | CSP-370 | 0006 | SP-75 | 000E | CSP-450 | 0007 | SP-110 | 000F | SP-04 | HEX | | 0000 | | 0000 ~ FFFF |
| | Parameter setting | Amplifier type | Parameter setting | Amplifier type | | | | | | | | | | | | | | | | | | | | | | | | | | | | | | | | | | | | | | | | | |
| | 0000 | — | 0008 | SP-150 | | | | | | | | | | | | | | | | | | | | | | | | | | | | | | | | | | | | | | | | | |
| | 0001 | SP-075 | 0009 | SP-185 | | | | | | | | | | | | | | | | | | | | | | | | | | | | | | | | | | | | | | | | | |
| | 0002 | SP-15 | 000A | SP-220 | | | | | | | | | | | | | | | | | | | | | | | | | | | | | | | | | | | | | | | | | |
| | 0003 | SP-22 | 000B | SP-260 | | | | | | | | | | | | | | | | | | | | | | | | | | | | | | | | | | | | | | | | | |
| | 0004 | SP-37 | 000C | SP-300 | | | | | | | | | | | | | | | | | | | | | | | | | | | | | | | | | | | | | | | | | |
| | 0005 | SP-55 | 000D | CSP-370 | | | | | | | | | | | | | | | | | | | | | | | | | | | | | | | | | | | | | | | | | |
| | 0006 | SP-75 | 000E | CSP-450 | | | | | | | | | | | | | | | | | | | | | | | | | | | | | | | | | | | | | | | | | |
| | 0007 | SP-110 | 000F | SP-04 | | | | | | | | | | | | | | | | | | | | | | | | | | | | | | | | | | | | | | | | | |
| | SP040 | MTYP | Motor type | This is valid when SP034 (SFNC2) bit -0 is set to 0. Set the applicable motor No. from the standard motors shown in section 4.2(3). | HEX | | 0000 | | 0000 ~ FFFF | | | | | | | | | | | | | | | | | | | | | | | | | | | | | | | | | | | | |
| SP041 | PTYP | Power supply type | This is set when this unit is a signal connection axis with the power supply unit. (Set to 0 when there is no axis connected.) Refer to section 4.2(3) for details. | HEX | | 0000 | | 0000 ~ FFFF | | | | | | | | | | | | | | | | | | | | | | | | | | | | | | | | | | | | | |
| SP042 | CRNG | C-axis detector range | The detector range for the C-axis is set. Set to 0. | DEC | | 0 | | 0 ~ 7 | | | | | | | | | | | | | | | | | | | | | | | | | | | | | | | | | | | | | |
| SP043 | TRNG | Synchronous tap/spindle synchronization detector range | The detector range for the synchronous tap/spindle synchronization is set. Set to 0. | DEC | | 0 | | 0 ~ 7 | | | | | | | | | | | | | | | | | | | | | | | | | | | | | | | | | | | | | |
| SP044 | TRANS | NC communication cycle | The cycle of communication with the NC is set. | DEC | | Standard = 0 Special = 1028 | | 0 ~ 32767 | | | | | | | | | | | | | | | | | | | | | | | | | | | | | | | | | | | | | |
| SP045 | | | Not used. Set to 0. | DEC | | 0 | | ~ | | | | | | | | | | | | | | | | | | | | | | | | | | | | | | | | | | | | | |
| SP046 | CSN2 | Speed command dual cushion | The speed command is smoothed only during the acceleration/deceleration start according to the acceleration/deceleration time constant set in SP019 (CSN1). The operation will be smoother when the value is small, but the acceleration/deceleration time will increase. Set to 0 to invalidate. | DEC | | 0 | | 0 ~ 1000 | | | | | | | | | | | | | | | | | | | | | | | | | | | | | | | | | | | | | |
| SP047 | SDTR | Speed detection reset value | The hysteresis width for the reset of the speed detection set value set in SP020 (SDTS) is set. | DEC | | 30 | r/min | 0 ~ 1000 | | | | | | | | | | | | | | | | | | | | | | | | | | | | | | | | | | | | | |
| SP048 | SUT | Speed reached range | The percentage of the speed deflection for where the speed reached signal is output is set. | DEC | | 15 | % | 0 ~ 100 | | | | | | | | | | | | | | | | | | | | | | | | | | | | | | | | | | | | | |
| SP049 | TLM2 | Torque limit 2 | The torque limit ratio for torque limit signal 010 is set. | DEC | | 20 | % | 1 ~ 120 | | | | | | | | | | | | | | | | | | | | | | | | | | | | | | | | | | | | | |
| SP050 | TLM3 | Torque limit 3 | The torque limit ratio for torque limit signal 011 is set. | DEC | | 30 | % | 1 ~ 120 | | | | | | | | | | | | | | | | | | | | | | | | | | | | | | | | | | | | | |
| SP051 | TLM4 | Torque limit 4 | The torque limit ratio for torque limit signal 100 is set. | DEC | | 40 | % | 1 ~ 120 | | | | | | | | | | | | | | | | | | | | | | | | | | | | | | | | | | | | | |
| SP052 | TLM5 | Torque limit 5 | The torque limit ratio for torque limit signal 101 is set. | DEC | | 50 | % | 1 ~ 120 | | | | | | | | | | | | | | | | | | | | | | | | | | | | | | | | | | | | | |
| SP053 | TLM6 | Torque limit 6 | The torque limit ratio for torque limit signal 110 is set. | DEC | | 60 | % | 1 ~ 120 | | | | | | | | | | | | | | | | | | | | | | | | | | | | | | | | | | | | | |
| SP054 | TLM7 | Torque limit 7 | The torque limit ratio for torque limit signal 111 is set. | DEC | | 70 | % | 1 ~ 120 | | | | | | | | | | | | | | | | | | | | | | | | | | | | | | | | | | | | | |
| SP055 | SETM | Speed deflection excessive timer | The time until the speed deflection excessive error is output is set. Set a value that is longer than the acceleration/deceleration time. | DEC | | 12 | sec | 0 ~ 60 | | | | | | | | | | | | | | | | | | | | | | | | | | | | | | | | | | | | | |

4. Status Display and Parameter Settings

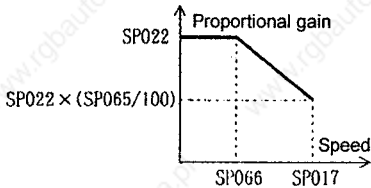
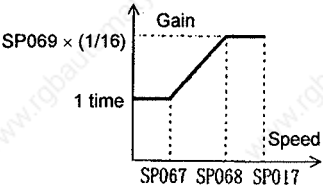
| Class | No. | Abbr. | Name | Description | TYP | CNG | Standard setting | Unit | Tolerable setting range | | | | | | | | | | | | | | | | |
|---------------------------------|------------------|------------------|--|--|---------------------------------|------------------|------------------|-----------------|-------------------------|---|---|---|-------------|------|------|----|--------------|------|-------|----|--|--|--|--|--|
| Spindle/machine specifications | SP056 | PYVR | Variable excitation | The minimum value of the variable excitation ratio is set. Select a small value when the gear sound, etc., is large, but a larger value is more effective for impact response. | DEC | * | 50 | % | 0 ~ 100 | | | | | | | | | | | | | | | | |
| | SP057 | | | Not used. Set to 0. | DEC | | 0 | | ~ | | | | | | | | | | | | | | | | |
| | SP058 | HSPT | Max. speed during S-analog high-speed tap | The max. motor speed for the S-analog 10V input when performing synchronous tap with the S-analog speed command is set. | DEC | | 6000 | r/min | 1 ~ 32767 | | | | | | | | | | | | | | | | |
| | SP059 | MKT | Coil changeover base shut off timer | The base shut off time for changing the contactor during coil change is set. The contactor may be burned if the value is too small. | DEC | | 150 | ms | 50 ~ 10000 | | | | | | | | | | | | | | | | |
| | SP060 | MKT2 | Current limit timer after coil changeover | The time to limit the current after contactor changeover is completed during coil changeover is set. | DEC | | 500 | ms | 0 ~ 10000 | | | | | | | | | | | | | | | | |
| | SP061 | MKIL | Current limit value after coil changeover | The current limit value that operates for only the time set in SP060 (MKT2) after contactor changeover is completed during coil changeover is set. | DEC | | 75 | % | 0 ~ 120 | | | | | | | | | | | | | | | | |
| | SP062 | | | Not used. Set to 0. | DEC | | 0 | | ~ | | | | | | | | | | | | | | | | |
| | SP063 | OLT | Overload alarm detection time | The detection time constant for motor overload alarm detection is set. | DEC | | 60 | sec | 0 ~ 1000 | | | | | | | | | | | | | | | | |
| | SP064 | OLL | Overload alarm detection level. | The detection level for the motor overload alarm detection is set. | DEC | | 110 | % | 0 ~ 200 | | | | | | | | | | | | | | | | |
| Speed control | SP065 | VCGN1 | Variable speed loop proportional gain target value | The speed loop proportional gain magnification for SP022 (VGNP1) in the motor max. speed set in SP017 (TSP) is set. | DEC | | 100 | % | 0 ~ 100 | | | | | | | | | | | | | | | | |
| | SP066 | VCSN1 | Variable speed loop proportional gain change start speed | The speed to start the speed loop proportional gain change is set.  | DEC | | 0 | r/min | 0 ~ 32767 | | | | | | | | | | | | | | | | |
| | SP067 | VIGWA | Variable current loop gain change start speed | The speed to start current loop gain change is set. | DEC | | 0 | | 0 ~ 32767 | | | | | | | | | | | | | | | | |
| | SP068 | VIGWB | Variable current loop gain change complete speed | The speed to complete current loop gain change is set. | DEC | | 0 | | 0 ~ 32767 | | | | | | | | | | | | | | | | |
| | SP069 | VIGN | Variable current loop gain target value | The current loop gain (torque amount and excitation amount) magnification in the change complete speed set in SP068 (VIGWB) is set. The magnification will be 1 when set to 0.  | DEC | | 0 | | 0 ~ 32767 | | | | | | | | | | | | | | | | |
| | | | | <p>(Note) Refer to the following table for guidelines to setting SP067 to SP069.</p> <table border="1" style="margin-left: auto; margin-right: auto;"> <thead> <tr> <th style="text-align: center;">Motor max. speed SP017 (TSP)</th> <th style="text-align: center;">SP067 (VIGWA)</th> <th style="text-align: center;">SP068 (VIGWB)</th> <th style="text-align: center;">SP069 (VIGN)</th> </tr> </thead> <tbody> <tr> <td style="text-align: center;">0 ~ 6000</td> <td style="text-align: center;">0</td> <td style="text-align: center;">0</td> <td style="text-align: center;">0</td> </tr> <tr> <td style="text-align: center;">6001 ~ 8000</td> <td style="text-align: center;">5000</td> <td style="text-align: center;">8000</td> <td style="text-align: center;">45</td> </tr> <tr> <td style="text-align: center;">8001 or more</td> <td style="text-align: center;">5000</td> <td style="text-align: center;">10000</td> <td style="text-align: center;">64</td> </tr> </tbody> </table> <p>The following apply to the above settings:</p> <ol style="list-style-type: none"> 1) When running at the max. speed, if the motor seems to hunt (high frequency vibration), lower SP068 in -8 increments, and set so that there is no problem. 2) When running at the max. speed, if the motor seems to groan (low frequency vibration), raise SP068 in +8 increments, and set so that there is no problem. 3) When decelerating from the max. speed, if the "overcurrent alarm 32" or "overvoltage alarm 75" occurs, the current loop gain may be insufficient in the high speed region. Thus, raise SP068 in +16 increments, and set so that there is no problem. | Motor max. speed SP017 (TSP) | SP067 (VIGWA) | SP068 (VIGWB) | SP069 (VIGN) | 0 ~ 6000 | 0 | 0 | 0 | 6001 ~ 8000 | 5000 | 8000 | 45 | 8001 or more | 5000 | 10000 | 64 | | | | | |
| Motor max. speed SP017 (TSP) | SP067 (VIGWA) | SP068 (VIGWB) | SP069 (VIGN) | | | | | | | | | | | | | | | | | | | | | | |
| 0 ~ 6000 | 0 | 0 | 0 | | | | | | | | | | | | | | | | | | | | | | |
| 6001 ~ 8000 | 5000 | 8000 | 45 | | | | | | | | | | | | | | | | | | | | | | |
| 8001 or more | 5000 | 10000 | 64 | | | | | | | | | | | | | | | | | | | | | | |

4. Status Display and Parameter Settings

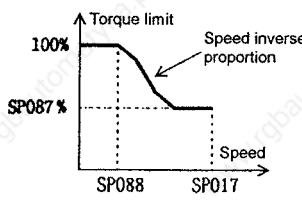
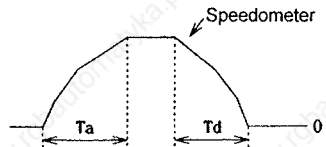
| Class | No. | Abbr. | Name | Description | TYP | CNG | Standard setting | Unit | Tolerable setting range |
|---------------|---------------|-------|--|---|-----|-----|------------------|-------|-------------------------|
| Speed control | SP070 | FHz | Machine resonance suppression filter frequency | If machine vibration occurs during speed or position control, set the frequency for suppressing the vibration. Note that a value that is 100Hz or more must be set. Set to 0 when not using. | DEC | * | 0 | Hz | 100 ~ 3000 |
| | SP071 ~ SP075 | | Fixed control constant | This is a parameter determined by Mitsubishi. Set 0 when there is no particular designation. | DEC | | 0 | | ~ |
| | SP076 | FONS | Machine resonance suppression filter activation speed | If the vibration is large when stopping the motor (ex., during orientation stop) when the machine vibration suppression filter is activated by SP070, activate the machine vibration suppression filter at a speed higher than that set in the parameter. The filter will be enabled for all speed ranges when 0 is set. | DEC | | 0 | r/min | 0 ~ 32767 |
| | SP077 | TDSL | Fixed control constant | This is a parameter determined by Mitsubishi. Set 14 when there is no particular designation. | DEC | | 14 | | |
| | SP078 ~ SP082 | | Fixed control constant | This is a parameter determined by Mitsubishi. Set 0 when there is no particular designation. | | | | | |
| | SP083 ~ SP086 | | | Not used. Set to 0. | | | | | |
| | SP087 | DIQM | Variable torque limit magnification target value during deceleration | The minimum value of the torque limit value fluctuated during deceleration is set. | DEC | | 75 | % | 0 ~ 150 |
| | SP088 | DIQN | Variable torque limit magnification change start speed during deceleration | The speed to start changing the torque limit value during deceleration is set.  <p>(Note) Refer to the following flow for the SP087 and SP088 setting and changing procedures. (SP088 does not need to be changed.) Adjust the deceleration time to a time equivalent to the acceleration time with SP087.</p> <p>Set the default values: SP087 = 75 SP088 = 3000</p> <p>* When using the machine with gears, measure with the H gears. With the coil changeover motor, measure with the H coil. Use the CN9 speedometer output for the measurement.</p> <pre> graph TD Start[Measure the acceleration/ deceleration waveform with the spindle max. speed command.] --> Q1{1. 1Ta < Td?} Q1 -- N --> Q2{0.95Ta > Td?} Q1 -- Y --> S1[SP087(+5)] S1 --> M1[Measure the acceleration/ deceleration waveform with the spindle max. speed command.] M1 --> Q3{1. 1Ta < Td?} Q3 -- Y --> S1 Q3 -- N --> Q4{0.95Ta > Td?} Q2 -- Y --> S2[SP087(-5)] S2 --> M2[Measure the acceleration/ deceleration waveform with the spindle max. speed command.] M2 --> Q5{0.95Ta > Td?} Q5 -- Y --> S2 Q5 -- N --> Set[Set the SP087 at this time.] style Set fill:#fff,stroke:#000 </pre>  | DEC | | | | 0 ~ 32767 |

4. Status Display and Parameter Settings

| Class | No. | Abbr. | Name | Description | TYP | CNG | Standard setting | Unit | Tolerable setting range |
|---------------------|-------|-------|--|---|-----|-----|------------------|---------------------------------|-------------------------|
| Speed control | SP089 | VGHP | Speed loop gain proportion item during S-analog high-speed tap | The speed loop proportional gain during S-analog high-speed tap is set. The response will improve when increased but the vibration and sound will increase. | DEC | | 63 | rad/s | 0 ~ 1000 |
| | SP090 | VGHI | Speed loop gain integral item during S-analog high-speed tap | The speed loop integral gain during S-analog high-speed tap is set. | DEC | | 60 | 1/10rad/s | 0 ~ 1000 |
| | SP091 | OFSN | Offset compensation during motor PLG forward run | The PLG offset value for forward run is set. Normally 0 is set. | DEC | * | 0 | -1mv | -2048~2047 |
| | SP092 | OFSI | Offset compensation during motor PLG reverse run | The PLG offset value for reverse run is set. Normally 0 is set. | DEC | * | 0 | -1mv | -2048~2047 |
| | SP093 | | | Not used. Set to 0. | DEC | | 0 | | ~ |
| | SP094 | LMAV | Load meter output filter | The filter time constant for load meter output is set. The time constant will be 100ms when the standard value 0 is set. | DEC | | 0 | 2ms | 0 ~ 32767 |
| | SP095 | | | Not used. Set to 0. | DEC | | 0 | | ~ |
| Orientation control | SP096 | EGAR | Encoder gear ratio | The gear ratio of the spindle end and encoder end (excluding motor built-in encoder) is set as follows: ① 1:1 Set value = 0 ② 1:2 Set value = 1 ③ 1:4 Set value = 2 ④ 1:8 Set value = 3 | DEC | | 0 | | 0 ~ 4 |
| | SP097 | SPECO | Orientation specification | This corresponds to the bit and selects the orientation specifications. Refer to section 4.2. (2) for details. | HEX | | 0000 | | 0000 ~ FFFF |
| | SP098 | VGOP | Speed loop gain proportional item during orientation | The speed loop proportional gain during orientation is set. The response will improve when increased but the vibration and sound will increase. | DEC | | 63 | rad/s | 0 ~ 1000 |
| | SP099 | VGOI | Speed loop gain integral item during orientation | The speed loop integral gain during orientation is set. | DEC | | 60 | 1/10rad/s | 0 ~ 1000 |
| | SP100 | VGOD | Speed loop gain delay advance item during orientation | The speed loop delay advance gain during orientation is set. PI control will be applied when set to 0. | DEC | | 15 | 1/10rad/s | 0 ~ 1000 |
| | SP101 | DINP | Orientation dummy in-position width | When using the orientation in-position advance function, set an in-position width that is larger than the standard in-position width SP004 (OINP). | DEC | | 16 | 1/16deg. | 1 ~ 2880 |
| | SP102 | OODR | Excessive error value during orientation | The excessive error width during orientation is set. | DEC | | 32767 | 1/4 pulse (1 pulse = 0.088deg.) | 1 ~ 32767 |
| | SP103 | FTM | Positioning complete off time timer | The time to forcibly turn off an index positioning complete signal other than the orientation complete signal due to the starting of the index start signal is set. | DEC | | 200 | ms | 1 ~ 10000 |
| | SP104 | TLOR | Torque control value during orientation servo lock | The torque limit value during orientation in-position output is set. Note that if the external torque limit signal is input, the torque limit value from this parameter will be invalid. | DEC | | 100 | % | 1 ~ 120 |
| | SP105 | IQGO | Current loop gain magnification 1 during orientation | The current loop gain (torque amount) magnification during orientation is set. | DEC | | 100 | % | 1 ~ 1000 |
| | SP106 | IDGO | Current loop gain magnification 2 during orientation | The current loop gain (excitation amount) magnification during orientation is set. | DEC | | 100 | % | 1 ~ 1000 |
| | SP107 | CSP2 | Deceleration ratio during orientation | The deceleration ratio during orientation for gear 001 is set. When the set value is 0, the setting will be the same as SP006 (CSP). | DEC | * | 0 | | 1 ~ 1000 |
| | SP108 | CSP3 | Deceleration ratio during orientation | The deceleration ratio during orientation for gear 010 is set. When the set value is 0, the setting will be the same as SP006 (CSP). | DEC | * | 0 | | 1 ~ 1000 |
| | SP109 | CSP4 | Deceleration ratio during orientation | The deceleration ratio during orientation for gear 011 is set. When the set value is 0, the setting will be the same as SP006 (CSP). | DEC | * | 0 | | 1 ~ 1000 |
| SP110 ~ SP113 | | | Not used. Set to 0. | DEC | | 0 | | ~ | |

4. Status Display and Parameter Settings

| Class | No. | Abbr. | Name | Description | TYP | CNG | Standard setting | Unit | Tolerable setting range |
|---------------------|---------------|-------|---|--|---------------------|-----|---|-----------------|-------------------------|
| Orientation control | SP114 | OPER | Orientation pulse miss check value | If the pulse miss value during orientation stop is higher than this setting, the alarm "5C" occurs. (Invalid when set to 0.) When using this setting, establish $SP114 > 1.5 \times SP004$ (orientation in-position width). | DEC | | 0 | 360/4096° | 0 ~ 32767 |
| | SP115 ~ SP118 | | | | Not used. Set to 0. | DEC | | 0 | ~ |
| | SP119 | MPGH | Orientation position gain H coil compensation magnification | The compensation magnification for the orientation position loop gain when using the H coil is set. Orientation position loop gain for H coil = $SP001$ or $SP002 \times SP119/256$ If 0 is set, the same value as $SP001$ or $SP002$ will be applied. | DEC | | 0 | 1/256 times | 0 ~ 2560 |
| | SP120 | MPGL | Orientation position gain L coil compensation magnification | The compensation magnification for the orientation position loop gain when using the L coil is set. Orientation position loop gain for L coil = $SP001$ or $SP002 \times SP120/256$ If 0 is set, the same value as $SP001$ or $SP002$ will be applied. | DEC | | 0 | 1/256 times | 0 ~ 2560 |
| | SP121 | MPCSH | Orientation deceleration rate H coil compensation magnification | The compensation magnification for the orientation deceleration rate when using the H coil is set. Orientation deceleration rate for H coil = $SP006 \times SP121/256$ If 0 is set, the same value as $SP006$ will be applied. | DEC | | 0 | 1/256 times | 0 ~ 2560 |
| | SP122 | MPCSL | Orientation deceleration rate L coil compensation magnification | The compensation magnification for the orientation deceleration rate when using the L coil is set. Orientation deceleration rate for L coil = $SP006 \times SP122/256$ If 0 is set, the same value as $SP006$ will be applied. | DEC | | 0 | 1/256 times | 0 ~ 2560 |
| | SP123 | MGDO | Magnesensor output peak value | This is the operation adjustment parameter for magnesensor orientation. Set the peak value of the magnesensor output. Increase the value if the gap between the sensor and magnet is small, and decrease the value when large. | DEC | * | Standard magnet = 542 Compact magnet = 500 | | 1 ~ 10000 |
| | SP124 | MGD1 | Magnesensor linear zone width | This is the operation adjustment parameter for magnesensor orientation. Set the magnesensor linear zone width. Decrease the value if the magnet installation radius is large, and increase when small. | DEC | * | Standard magnet = 768 Compact magnet = 440 | | 1 ~ 10000 |
| | SP125 | MGD2 | Magnesensor changeover point | This is the operation adjustment parameter for magnesensor orientation. Set the distance from the target stop point when changing the position feedback to the magnesensor output. Normally, a value that is approximately half of $SP124$ is set. | DEC | * | Standard magnet = 384 Compact magnet = 220 | | 1 ~ 10000 |
| | SP126 ~ SP128 | | | | Not used. Set to 0. | DEC | | 0 | ~ |
| C-axis control | SP129 | SPECC | C-axis specifications | This corresponds to bits, and sets the C-axis specifications. Refer to section 4.2.(2) for details. | HEX | | 0000 | | 0000 ~ FFFF |
| | SP130 | PGC1 | No. 1 position loop gain during C-axis cutting | The position loop gain when No. 1 (standard cutting gain) gain is selected during C-axis cutting is set. | DEC | * | 15 | rad/sec (1/sec) | 1 ~ 100 |
| | SP131 | PGC2 | No. 2 position loop gain during C-axis cutting | The position loop gain when No. 2 (interpolation cutting gain) gain is selected during C-axis cutting is set. | DEC | * | 15 | rad/sec (1/sec) | 1 ~ 100 |
| | SP132 | PGC3 | No. 3 position loop gain during C-axis cutting | The position loop gain when No. 3 (heavy cutting gain) gain is selected during C-axis cutting is set. | DEC | * | 15 | rad/sec (1/sec) | 1 ~ 100 |
| | SP133 | PGC4 | No. 4 position loop gain during C-axis cutting | The position loop gain when No. 4 (gain when cutting is stopped) gain is selected during C-axis cutting is set. | DEC | * | 15 | rad/sec (1/sec) | 1 ~ 100 |
| | SP134 | VGCP0 | Speed loop gain proportion item during C-axis non-cutting | The speed loop proportional gain during C-axis non-cutting is set. | DEC | | 63 | rad/s | 0 ~ 5000 |
| | SP135 | VGCI0 | Speed loop gain integral item during C-axis non-cutting | The speed loop integral gain during C-axis non-cutting is set. | DEC | | 60 | 1/10rad/s | 0 ~ 5000 |
| | SP136 | VGCD0 | Speed loop gain delay advance item during C-axis non-cutting | The speed loop delay advance gain during C-axis non-cutting is set. PI control will be applied when set to 0. | DEC | | 15 | 1/10rad/s | 0 ~ 5000 |
| | SP137 | VGCP1 | No. 1 speed loop gain proportion item during C-axis cutting | The speed loop proportional gain when No. 1 gain is selected during C-axis cutting is set. | DEC | | 63 | rad/s | 0 ~ 5000 |

4. Status Display and Parameter Settings

| Class | No. | Abbr. | Name | Description | TYP | CNG | Standard setting | Unit | Tolerable setting range |
|----------------|---------------|---|---|---|-----|-----|------------------|------------------------------------|-------------------------|
| C-axis control | SP138 | VGCI1 | No. 1 speed loop gain integral item during C-axis cutting | The speed loop integral gain when No. 1 gain is selected during C-axis cutting is set. | DEC | | 60 | 1/10rad/s | 0 ~ 5000 |
| | SP139 | VGCD1 | No. 1 speed loop gain delay advance item during C-axis cutting | The speed loop delay advance gain when No. 1 gain is selected during C-axis cutting is set. PI control will be applied when set to 0. | DEC | | 15 | 1/10rad/s | 0 ~ 5000 |
| | SP140 | VGCP2 | No. 2 speed loop gain proportion item during C-axis cutting | The speed loop proportional gain when No. 2 gain is selected during C-axis cutting is set. | DEC | | 63 | rad/s | 0 ~ 5000 |
| | SP141 | VGCI2 | No. 2 speed loop gain integral item during C-axis cutting | The speed loop integral gain when No. 2 gain is selected during C-axis cutting is set. | DEC | | 60 | 1/10rad/s | 0 ~ 5000 |
| | SP142 | VGCD2 | No. 2 speed loop gain delay advance item during C-axis cutting | The speed loop delay advance gain when No. 2 gain is selected during C-axis cutting is set. PI control will be applied when set to 0. | DEC | | 15 | 1/10rad/s | 0 ~ 5000 |
| | SP143 | VGCP3 | No. 3 speed loop gain proportion item during C-axis cutting | The speed loop proportional gain when No. 3 gain is selected during C-axis cutting is set. | DEC | | 63 | rad/s | 0 ~ 5000 |
| | SP144 | VGCI3 | No. 3 speed loop gain integral item during C-axis cutting | The speed loop integral gain when No. 3 gain is selected during C-axis cutting is set. | DEC | | 60 | 1/10rad/s | 0 ~ 5000 |
| | SP145 | VGCD3 | No. 3 speed loop gain delay advance item during C-axis cutting | The speed loop delay advance gain when No. 3 gain is selected during C-axis cutting is set. PI control will be applied when set to 0. | DEC | | 15 | 1/10rad/s | 0 ~ 5000 |
| | SP146 | VGCP4 | Speed loop gain proportion item during C-axis cutting stop | The speed loop proportional gain during C-axis cutting stop is set. | DEC | | 63 | rad/s | 0 ~ 5000 |
| | SP147 | VGCI4 | Speed loop gain integral item during C-axis cutting stop | The speed loop integral gain during C-axis cutting stop is set. | DEC | | 60 | 1/10rad/s | 0 ~ 5000 |
| | SP148 | VGCD4 | Speed loop gain delay advance item during C-axis cutting stop | The speed loop delay advance gain during C-axis cutting stop is set. PI control will be applied when set to 0. | DEC | | 15 | 1/10rad/s | 0 ~ 5000 |
| | SP149 | CZRN | C-axis zero point return speed | This is valid when SP129 (SPECC)-bitE is set to 0. The zero point return speed for when changing from the speed loop to position loop is set. | DEC | * | 50 | r/min | 1 ~ 500 |
| | SP150 | CPDT | C-axis zero point return deceleration point | This is valid when SP129 (SPECC)-bitE is set to 0. The deceleration point for when decelerating from the C-axis zero point return speed to the target stop. If there is any sway when stopping, decrease the value. | DEC | * | 1 | | 1 ~ 10000 |
| | SP151 | CPSTL | C-axis zero point return shift amount (Low byte) | This is valid when SP129 (SPECC)-bit E is set to 0. This sets C-axis zero point. | HEX | * | H:0000 | 1/1000deg. | 00000000 ~FFFFFF |
| | SP152 | CPSTL | C-axis zero point return shift amount (High byte) | | | | L:0000 | | |
| | SP153 | CINP | C-axis in-position width | The position error range where the in-position signal is output during C-axis is set. | HEX | * | 03E8 | 1/1000deg. | 0000 ~FFFF |
| | SP154 | CODRL | Excessive error width during C-axis (Low byte) | The excessive error width during C-axis is set. | HEX | * | H:0001 | pulse (1 pulse = 1/1000deg.) | 00000000 ~FFFFFF |
| | SP155 | CODRH | Excessive error width during C-axis (High byte) | | | | L:D4C0 | | |
| | SP156 ~ SP158 | | | Not used. Set to 0. | DEC | | 0 | | ~ |
| | SP159 | CPYC | Variable excitation ratio during C-axis non-cutting | The min. value of the variable excitation ratio during C-axis non-cutting is set. | DEC | * | 50 | % | 0 ~ 100 |
| SP160 | CPYX | Variable excitation ratio during C-axis cutting | The min. value of the variable excitation ratio during C-axis cutting is set. | DEC | * | 100 | % | 0 ~ 100 | |
| SP161 | IQGC0 | Current loop gain during C-axis non-cutting Magnification 1 | The current loop gain (torque amount) magnification during C-axis non-cutting is set. | DEC | | 100 | % | 0 ~ 1000 | |
| SP162 | IDGC0 | Current loop gain during C-axis non-cutting Magnification 2 | The current loop gain (exciting amount) magnification during C-axis non-cutting is set. | DEC | | 100 | % | 0 ~ 1000 | |

4. Status Display and Parameter Settings

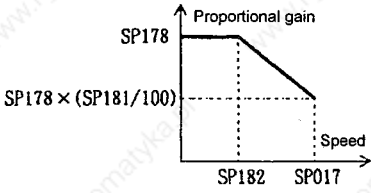
| Class | No. | Abbr. | Name | Description | TYP | CNG | Standard setting | Unit | Tolerable setting range |
|-------------------------|---------------|-------|---|--|-----|-----|------------------|-----------------------------|-------------------------|
| C-axis control | SP163 | IQCG1 | Current loop gain during C-axis cutting Magnification 1 | The current loop gain (torque amount) magnification during C-axis cutting is set. | DEC | | 100 | % | 0 ~ 1000 |
| | SP164 | IDGC1 | Current loop gain during C-axis cutting Magnification 2 | The current loop gain (exciting amount) magnification during C-axis cutting is set. | DEC | | 100 | % | 0 ~ 1000 |
| | SP165 | PG2C | C-axis position loop gain 2 | Set the No. 2 position loop gain when performing high-gain control during C-axis control. This applies to all operation modes in the C-axis control. Set to 0 when not using. | DEC | * | 0 | rad/sec (1/sec) | 0 ~ 999 |
| | SP166 | PG3C | C-axis position loop gain 3 | Set the No. 3 position loop gain when performing high-gain control during C-axis control. This applies to all operation modes in the C-axis control. Set to 0 when not using. | DEC | * | 0 | rad/sec (1/sec) | 0 ~ 999 |
| | SP167 ~ SP176 | | | Not used. Set to 0. | DEC | | 0 | | ~ |
| Spindle synchronization | SP177 | SPECS | Spindle synchronization specifications | This corresponds to bits and sets the spindle synchronization specifications. Refer to section 4.2(2) for details. | HEX | | 0000 | | 0000 ~ FFFF |
| | SP178 | VGSP | Speed loop gain proportion item during spindle synchronization | The speed loop proportional gain during spindle synchronization is set. | DEC | | 63 | rad/s | 0 ~ 1000 |
| | SP179 | VGS1 | Speed loop gain integral item during spindle synchronization | The speed loop integral gain during spindle synchronization is set. | DEC | | 60 | 1/10rad/s | 0 ~ 1000 |
| | SP180 | VGSD | Speed loop gain delay advance item during spindle synchronization | The speed loop delay advance gain during spindle synchronization is set. PI control will be applied when set to 0. | DEC | | 15 | 1/10rad/s | 0 ~ 1000 |
| | SP181 | VCGS | Variable speed loop proportional gain target value during spindle synchronization | The speed loop proportional gain magnification for SP178 (VGSP) in the max. motor speed set with SP017 (TSP) during spindle synchronization is set. | DEC | | 100 | % | 0 ~ 100 |
| | SP182 | VCSS | Variable speed loop proportional gain change start speed during spindle synchronization | The speed where speed loop proportional gain change starts during spindle synchronization is set.  | DEC | | 0 | r/min | 0 ~ 32767 |
| | SP183 | SYNV | Synchronization match speed during spindle synchronization | The speed command error range where the synchronization speed match signal is output when changing from the speed loop to the position loop during spindle synchronization is set. | DEC | * | 20 | r/min | 0 ~ 1000 |
| | SP184 | | | Not used. Set to 0. | DEC | | 0 | | ~ |
| | SP185 | SINP | Spindle synchronization in-position width | The position error range where the in-position signal is output during spindle synchronization is set. | DEC | * | 16 | 1/16deg. | 1 ~ 2880 |
| | SP186 | SODR | Excessive error width during spindle synchronization | The excessive error width during spindle synchronization is set. | DEC | | 32767 | pulse (1 pulse = 0.088deg.) | 1 ~ 32767 |
| | SP187 | IQGS | Current loop gain magnification 1 during spindle synchronization | The current loop gain (torque amount) magnification during spindle synchronization is set. | DEC | | 100 | % | 1 ~ 1000 |
| | SP188 | IDGS | Current loop gain magnification 2 during spindle synchronization | The current loop gain (exciting amount) magnification during spindle synchronization is set. | DEC | | 100 | % | 0 ~ 1000 |
| | SP189 | PG2S | Position loop gain 2 during spindle synchronization | Set the No. 2 position loop gain when performing high-gain control during spindle synchronization. Set to 0 when not using. | DEC | * | 0 | rad/sec (1/sec) | 0 ~ 999 |

4. Status Display and Parameter Settings

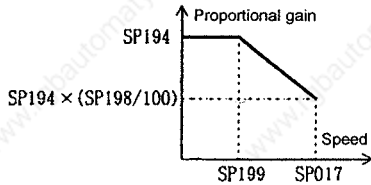
| Class | No. | Abbr. | Name | Description | TYP | CNG | Standard setting | Unit | Tolerable setting range | |
|-------------------------|---------------|-------|---|---|---------------------|-----|------------------|-----------------------------|-------------------------|---|
| Synchronous tap control | SP190 | PG3S | Position loop gain 3 during spindle synchronization | Set the No. 3 position loop gain when performing high-gain control during spindle synchronization. Set to 0 when not using. | DEC | * | 0 | rad/sec (1/sec) | 0 ~ 999 | |
| | SP191 ~ SP192 | | | Not used. Set to 0. | DEC | | 0 | | ~ | |
| | SP193 | SPECT | Synchronous tap specifications | This corresponds to bits and sets the synchronous tap specifications. Refer to 4.2(2) for details. | HEX | | 0000 | | 0000 ~ FFFF | |
| | SP194 | VGTP | Speed loop gain proportion item during synchronous tap | The speed loop proportional gain during synchronous tap is set. | DEC | | 63 | rad/s | 0 ~ 1000 | |
| | SP195 | VGT1 | Speed loop gain integral item during synchronous tap | The speed loop integral gain during synchronous tap is set. | DEC | | 60 | 1/10rad/s | 0 ~ 1000 | |
| | SP196 | VGTD | Speed loop gain delay advance item during synchronous tap | The speed loop delay advance gain during synchronous tap is set. PI control will be applied when set to 0. | DEC | | 15 | 1/10rad/s | 0 ~ 1000 | |
| | SP197 | | | Not used. Set to 0. | DEC | | 0 | | ~ | |
| | SP198 | VCGT | Variable speed loop proportional gain target value during synchronous tap | The speed loop proportional gain magnification for SP194 (VGSP) in the max. motor speed set with SP017 (TSP) during synchronous tap is set. | DEC | | 100 | % | 0 ~ 100 | |
| | SP199 | VCST | Variable speed loop proportional gain change start speed during synchronous tap | The speed where speed loop proportional gain change starts during synchronous tap is set.  | DEC | | 0 | r/min | 0 ~ 32767 | |
| | SP200 | FFC1 | Synchronous tap acceleration feed forward gain (Gear 1) | The acceleration feed forward gain when gear 000 is selected in the synchronous tap is set. Set when the relative position error with the Z-axis servo is large. | DEC | | 0 | % | 0 ~ 1000 | |
| | SP201 | FFC2 | Synchronous tap acceleration feed forward gain (Gear 2) | The acceleration feed forward gain when gear 001 is selected in the synchronous tap is set. | DEC | | 0 | % | 0 ~ 1000 | |
| | SP202 | FFC3 | Synchronous tap acceleration feed forward gain (Gear 3) | The acceleration feed forward gain when gear 010 is selected in the synchronous tap is set. | DEC | | 0 | % | 0 ~ 1000 | |
| | SP203 | FFC4 | Synchronous tap acceleration feed forward gain (Gear 4) | The acceleration feed forward gain when gear 011 is selected in the synchronous tap is set. | DEC | | 0 | % | 0 ~ 1000 | |
| | SP204 ~ SP213 | | | | Not used. Set to 0. | DEC | | 0 | | ~ |
| | SP214 | TZRN | Synchronous tap zero point return speed | This is valid when SP193 (SPECT)-bit E is set to 0. The zero point return speed for when changing from the speed loop to position loop is set. | DEC | * | 50 | r/min | 1 ~ 500 | |
| | SP215 | TPDT | Synchronous tap zero point return deceleration point | This is valid when SP193 (SPECT)-bit E is set to 0. The deceleration point for when decelerating from the synchronous tap zero point return speed to the target stop point. If there is any sway when stopping, increase the value. | DEC | * | 1 | | 1 ~ 10000 | |
| | SP216 | TPST | Synchronous tap zero point return shift amount | This is valid when SP193 (SPECT)-bit E is set to 0. Synchronous tap zero point is set. | DEC | * | 0 | | 1 ~ 4095 | |
| | SP217 | TINP | Synchronous tap inposition width | The position error range where the in-position signal is output during synchronous tap is set. | DEC | * | 16 | 1/16deg. | 1 ~ 2880 | |
| | SP218 | TODR | Excessive error width during synchronous tap | The excessive error width during synchronous tap is set. | DEC | | 32767 | pulse (1 pulse = 0.088deg.) | 1 ~ 32767 | |
| | SP219 | IQGT | Current loop gain magnification 1 during synchronous tap | The current loop gain (torque amount) magnification during synchronous tap is set. | DEC | | 100 | % | 1 ~ 1000 | |
| | SP220 | IDGT | Current loop gain magnification 2 during synchronous tap | The current loop gain (exciting amount) magnification during synchronous tap is set. | DEC | | 100 | % | 1 ~ 1000 | |

4. Status Display and Parameter Settings

| Class | No. | Abbr. | Name | Description | TYP | CNG | Standard setting | Unit | Tolerable setting range |
|----------------|---------------------|------------------------------------|--|--|-----|-----|------------------|-----------------|-------------------------|
| | SP221 | PG2T | Position loop gain 2 during synchronous tap | Set the No. 2 position loop gain when performing high-gain control during synchronous tap. Set to 0 when not using. | DEC | * | 0 | rad/sec (1/sec) | 0 ~ 999 |
| | SP222 | PG3T | Position loop gain 3 during synchronous tap | Set the No. 3 position loop gain when performing high-gain control during synchronous tap. Set to 0 when not using. | DEC | * | 0 | rad/sec (1/sec) | 0 ~ 999 |
| | SP223 ~ SP224 | | | Not used. Set to 0. | DEC | | 0 | | ~ |
| Others | SP225 | GRA5 | Spindle side No. of gear teeth 5 | The No. of gear teeth on the spindle side is set for gear 100. | DEC | | 1 | | 1 ~ 32767 |
| | SP226 | GRA6 | Spindle side No. of gear teeth 6 | The No. of gear teeth on the spindle side is set for gear 101. | DEC | | 1 | | 1 ~ 32767 |
| | SP227 | GRA7 | Spindle side No. of gear teeth 7 | The No. of gear teeth on the spindle side is set for gear 110. | DEC | | 1 | | 1 ~ 32767 |
| | SP228 | GRA8 | Spindle side No. of gear teeth 8 | The No. of gear teeth on the spindle side is set for gear 111. | DEC | | 1 | | 1 ~ 32767 |
| | SP229 | GRB5 | Motor side No. of gear teeth 5 | The No. of gear teeth on the motor side is set for gear 100. | DEC | | 1 | | 1 ~ 32767 |
| | SP230 | GRB6 | Motor side No. of gear teeth 6 | The No. of gear teeth on the motor side is set for gear 101. | DEC | | 1 | | 1 ~ 32767 |
| | SP231 | GRB7 | Motor side No. of gear teeth 7 | The No. of gear teeth on the motor side is set for gear 110. | DEC | | 1 | | 1 ~ 32767 |
| | SP232 | GRB8 | Motor side No. of gear teeth 8 | The No. of gear teeth on the motor side is set for gear 111. | DEC | | 1 | | 1 ~ 32767 |
| | SP233 ~ SP252 | | | Not used. Set to 0. | DEC | | 0 | | ~ |
| | SP253 | DA1NO | D/A output channel 1 data No. | The output data No. for the No.1 channel in the D/A output function is set. When set to 0, the speedometer will be output. Refer to section 4.2.(4) for details. | DEC | * | 0 | | 0 ~ 32767 |
| | SP254 | DA2NO | D/A output channel 2 data No. | The output data No. for the No.2 channel in the D/A output function is set. When set to 0, the speedometer will be output. | DEC | * | 0 | | 0 ~ 32767 |
| SP255 | DA1MPY | D/A output channel 1 magnification | The magnification of the output data for No. 1 channel in the D/A output function is set. When set to 0, the magnification will be 1. Refer to section 4.2.(4) for details. | DEC | * | 0 | 1/256 times | 0 ~ 32767 | |
| SP256 | DA2MPY | D/A output channel 2 magnification | The magnification of the output data for No. 2 channel in the D/A output function is set. When set to 0, the magnification will be 1. | DEC | * | 0 | 1/256 times | 0 ~ 32767 | |
| Motor constant | SP257 } SP320 | RPM } BSD | Motor constant (H coil) | This is valid only in the following two cases: ① When SP034 (SFNC2) – bit0 = 1, and SP034 (SFNC2) – bit2 = 0. Set the motor constants when the special motor being used is not noted in section 4.2.(3) and is not a coil changeover motor. ② When SP034 (SFNC2) – bit0 = 1, and SP034 (SFNC2) – bit2 = 1. Set the motor constants for the H coil side on the coil changeover motor. (Note) The setting must not be changed by the user. | HEX | | 0000 | | 0000 ~ FFFF |
| | SP321 } SP384 | RPML } BSDL | Motor constant (L coil) | This is valid only in the following case: ① When SP034 (SFNC2) – bit0 = 1, and SP034 (SFNC2) – bit2 = 1. Set the motor constants for the L coil side on the coil changeover motor. (Note) The setting must not be changed by the user. | HEX | | 0000 | | 0000 ~ FFFF |

4. Status Display and Parameter Settings

(2) Details of parameters corresponding to bits

| Name | Abbr. | Description | TYP | | | | | | | | | | | | | | | | | | | | | | | | | | | | | | | | |
|-------|-------|---|-----|---|---|---|---|---|---|---|---|---|---|---|---|---|---|---|--|--|--|--|--|--|--|--|--|--|--|--|--|--|--|--|----------------|
| SP033 | SFNC1 | <table style="width: 100%; text-align: center; border-collapse: collapse;"> <tr> <td>F</td><td>E</td><td>D</td><td>C</td><td>B</td><td>A</td><td>9</td><td>8</td><td>7</td><td>6</td><td>5</td><td>4</td><td>3</td><td>2</td><td>1</td><td>0</td> </tr> <tr> <td style="border: 1px solid black; width: 20px; height: 15px;"></td> <td style="border: 1px solid black; width: 20px; height: 15px;"></td> <td style="border: 1px solid black; width: 20px; height: 15px;"></td> <td style="border: 1px solid black; width: 20px; height: 15px;"></td> <td style="border: 1px solid black; width: 20px; height: 15px;"></td> <td style="border: 1px solid black; width: 20px; height: 15px;"></td> <td style="border: 1px solid black; width: 20px; height: 15px;"></td> <td style="border: 1px solid black; width: 20px; height: 15px;"></td> <td style="border: 1px solid black; width: 20px; height: 15px;"></td> <td style="border: 1px solid black; width: 20px; height: 15px;"></td> <td style="border: 1px solid black; width: 20px; height: 15px;"></td> <td style="border: 1px solid black; width: 20px; height: 15px;"></td> <td style="border: 1px solid black; width: 20px; height: 15px;"></td> <td style="border: 1px solid black; width: 20px; height: 15px;"></td> <td style="border: 1px solid black; width: 20px; height: 15px;"></td> <td style="border: 1px solid black; width: 20px; height: 15px;"></td> </tr> </table> <p>[1a2m] 1-amplifier 2-motor function (0: invalid/1: valid) [dfmt] Default motor (0: main/1: sub) [sftk] SF-TK card validity (0: invalid/1: valid)</p> | F | E | D | C | B | A | 9 | 8 | 7 | 6 | 5 | 4 | 3 | 2 | 1 | 0 | | | | | | | | | | | | | | | | | HEX setting |
| F | E | D | C | B | A | 9 | 8 | 7 | 6 | 5 | 4 | 3 | 2 | 1 | 0 | | | | | | | | | | | | | | | | | | | | |
| | | | | | | | | | | | | | | | | | | | | | | | | | | | | | | | | | | | |
| SP034 | SFNC2 | <table style="width: 100%; text-align: center; border-collapse: collapse;"> <tr> <td>F</td><td>E</td><td>D</td><td>C</td><td>B</td><td>A</td><td>9</td><td>8</td><td>7</td><td>6</td><td>5</td><td>4</td><td>3</td><td>2</td><td>1</td><td>0</td> </tr> <tr> <td style="border: 1px solid black; width: 20px; height: 15px;"></td> <td style="border: 1px solid black; width: 20px; height: 15px;"></td> <td style="border: 1px solid black; width: 20px; height: 15px;"></td> <td style="border: 1px solid black; width: 20px; height: 15px;"></td> <td style="border: 1px solid black; width: 20px; height: 15px;"></td> <td style="border: 1px solid black; width: 20px; height: 15px;"></td> <td style="border: 1px solid black; width: 20px; height: 15px;"></td> <td style="border: 1px solid black; width: 20px; height: 15px;"></td> <td style="border: 1px solid black; width: 20px; height: 15px;"></td> <td style="border: 1px solid black; width: 20px; height: 15px;"></td> <td style="border: 1px solid black; width: 20px; height: 15px;"></td> <td style="border: 1px solid black; width: 20px; height: 15px;"></td> <td style="border: 1px solid black; width: 20px; height: 15px;"></td> <td style="border: 1px solid black; width: 20px; height: 15px;"></td> <td style="border: 1px solid black; width: 20px; height: 15px;"></td> <td style="border: 1px solid black; width: 20px; height: 15px;"></td> </tr> </table> <p>[mtsl] Motor constant (0: standard/1: special) [invm] General-purpose motor function (0: invalid/1: valid) [mkch] Coil changeover function (0: invalid/1: valid)</p> | F | E | D | C | B | A | 9 | 8 | 7 | 6 | 5 | 4 | 3 | 2 | 1 | 0 | | | | | | | | | | | | | | | | | HEX setting |
| F | E | D | C | B | A | 9 | 8 | 7 | 6 | 5 | 4 | 3 | 2 | 1 | 0 | | | | | | | | | | | | | | | | | | | | |
| | | | | | | | | | | | | | | | | | | | | | | | | | | | | | | | | | | | |
| SP035 | SFNC3 | <table style="width: 100%; text-align: center; border-collapse: collapse;"> <tr> <td>F</td><td>E</td><td>D</td><td>C</td><td>B</td><td>A</td><td>9</td><td>8</td><td>7</td><td>6</td><td>5</td><td>4</td><td>3</td><td>2</td><td>1</td><td>0</td> </tr> <tr> <td style="border: 1px solid black; width: 20px; height: 15px;"></td> <td style="border: 1px solid black; width: 20px; height: 15px;"></td> <td style="border: 1px solid black; width: 20px; height: 15px;"></td> <td style="border: 1px solid black; width: 20px; height: 15px;"></td> <td style="border: 1px solid black; width: 20px; height: 15px;"></td> <td style="border: 1px solid black; width: 20px; height: 15px;"></td> <td style="border: 1px solid black; width: 20px; height: 15px;"></td> <td style="border: 1px solid black; width: 20px; height: 15px;"></td> <td style="border: 1px solid black; width: 20px; height: 15px;"></td> <td style="border: 1px solid black; width: 20px; height: 15px;"></td> <td style="border: 1px solid black; width: 20px; height: 15px;"></td> <td style="border: 1px solid black; width: 20px; height: 15px;"></td> <td style="border: 1px solid black; width: 20px; height: 15px;"></td> <td style="border: 1px solid black; width: 20px; height: 15px;"></td> <td style="border: 1px solid black; width: 20px; height: 15px;"></td> <td style="border: 1px solid black; width: 20px; height: 15px;"></td> </tr> </table> <p>[hwid] High-speed coil wide constant output (0: invalid/1: valid) [lwid] Low-speed coil wide constant output (0: invalid/1: valid) [hbsd] High-speed coil base slide (0: invalid/1: valid) [lbsd] Low-speed coil base slide (0: invalid/1: valid)</p> | F | E | D | C | B | A | 9 | 8 | 7 | 6 | 5 | 4 | 3 | 2 | 1 | 0 | | | | | | | | | | | | | | | | | HEX setting |
| F | E | D | C | B | A | 9 | 8 | 7 | 6 | 5 | 4 | 3 | 2 | 1 | 0 | | | | | | | | | | | | | | | | | | | | |
| | | | | | | | | | | | | | | | | | | | | | | | | | | | | | | | | | | | |

4. Status Display and Parameter Settings

| Name | Abbr. | Description | TYP | | | | | | | | | | | | | | | | | | | | | | | | | | | | | | | | |
|-------|-------|--|-----|---|---|------|------|---|---|------|------|------|------|------|------|---|---|---|------|--|--|--|--|--|------|------|--|--|------|------|------|------|------|------|-------------|
| SP036 | SFNC4 | <table style="width: 100%; border-collapse: collapse; margin-bottom: 10px;"> <tr> <td style="text-align: center;">F</td><td style="text-align: center;">E</td><td style="text-align: center;">D</td><td style="text-align: center;">C</td><td style="text-align: center;">B</td><td style="text-align: center;">A</td><td style="text-align: center;">9</td><td style="text-align: center;">8</td><td style="text-align: center;">7</td><td style="text-align: center;">6</td><td style="text-align: center;">5</td><td style="text-align: center;">4</td><td style="text-align: center;">3</td><td style="text-align: center;">2</td><td style="text-align: center;">1</td><td style="text-align: center;">0</td> </tr> <tr> <td style="border: 1px solid black; width: 20px;"></td><td style="border: 1px solid black; width: 20px;"></td><td style="border: 1px solid black; width: 20px;"></td><td style="border: 1px solid black; width: 20px;"></td><td style="border: 1px solid black; width: 20px;"></td><td style="border: 1px solid black; width: 20px;"></td><td style="border: 1px solid black; width: 20px; text-align: center;">dslm</td><td style="border: 1px solid black; width: 20px; text-align: center;">dssm</td><td style="border: 1px solid black; width: 20px;"></td><td style="border: 1px solid black; width: 20px;"></td><td style="border: 1px solid black; width: 20px; text-align: center;">enc2</td><td style="border: 1px solid black; width: 20px; text-align: center;">enc1</td><td style="border: 1px solid black; width: 20px; text-align: center;">mag2</td><td style="border: 1px solid black; width: 20px; text-align: center;">mag1</td><td style="border: 1px solid black; width: 20px; text-align: center;">plg2</td><td style="border: 1px solid black; width: 20px; text-align: center;">plg1</td> </tr> </table> <p>The control method for the 1-amplifier 2-motor use is set.</p> <p>[plg1] PLG for motor 1 (0: valid/1: invalid) [plg2] PLG for motor 2 (0: valid/1: invalid) [mag1] MAG for motor 1 (0: valid/1: invalid) [mag2] MAG for motor 2 (0: valid/1: invalid) [enc1] ENC for motor 1 (0: valid/1: invalid) [enc2] ENC for motor 2 (0: valid/1: invalid)</p> <p>[dssm] Speedometer output (0: Output/1: Do not output) [dslm] Load meter output (0: Output/1: Do not output)</p> | F | E | D | C | B | A | 9 | 8 | 7 | 6 | 5 | 4 | 3 | 2 | 1 | 0 | | | | | | | dslm | dssm | | | enc2 | enc1 | mag2 | mag1 | plg2 | plg1 | HEX setting |
| F | E | D | C | B | A | 9 | 8 | 7 | 6 | 5 | 4 | 3 | 2 | 1 | 0 | | | | | | | | | | | | | | | | | | | | |
| | | | | | | dslm | dssm | | | enc2 | enc1 | mag2 | mag1 | plg2 | plg1 | | | | | | | | | | | | | | | | | | | | |
| SP037 | SFNC5 | <table style="width: 100%; border-collapse: collapse; margin-bottom: 10px;"> <tr> <td style="text-align: center;">F</td><td style="text-align: center;">E</td><td style="text-align: center;">D</td><td style="text-align: center;">C</td><td style="text-align: center;">B</td><td style="text-align: center;">A</td><td style="text-align: center;">9</td><td style="text-align: center;">8</td><td style="text-align: center;">7</td><td style="text-align: center;">6</td><td style="text-align: center;">5</td><td style="text-align: center;">4</td><td style="text-align: center;">3</td><td style="text-align: center;">2</td><td style="text-align: center;">1</td><td style="text-align: center;">0</td> </tr> <tr> <td style="border: 1px solid black; width: 20px;"></td><td style="border: 1px solid black; width: 20px;"></td><td style="border: 1px solid black; width: 20px;"></td><td style="border: 1px solid black; width: 20px;"></td><td style="border: 1px solid black; width: 20px;"></td><td style="border: 1px solid black; width: 20px;"></td><td style="border: 1px solid black; width: 20px;"></td><td style="border: 1px solid black; width: 20px; text-align: center;">nstv</td><td style="border: 1px solid black; width: 20px;"></td><td style="border: 1px solid black; width: 20px;"></td><td style="border: 1px solid black; width: 20px;"></td><td style="border: 1px solid black; width: 20px;"></td><td style="border: 1px solid black; width: 20px;"></td><td style="border: 1px solid black; width: 20px; text-align: center;">plgo</td><td style="border: 1px solid black; width: 20px; text-align: center;">mago</td><td style="border: 1px solid black; width: 20px; text-align: center;">enco</td> </tr> </table> <p>The orientation position detector, etc. is set.</p> <p>[enco] Encoder orientation Note: Do not set two or more of bits 0 to 2 to "1" at the same time. [mago] Magnesensor orientation [plgo] PLG orientation</p> <p>[nstv] No signal detection type (0: constant monitor/ 1: only during position loop or orientation)</p> | F | E | D | C | B | A | 9 | 8 | 7 | 6 | 5 | 4 | 3 | 2 | 1 | 0 | | | | | | | | nstv | | | | | | plgo | mago | enco | HEX setting |
| F | E | D | C | B | A | 9 | 8 | 7 | 6 | 5 | 4 | 3 | 2 | 1 | 0 | | | | | | | | | | | | | | | | | | | | |
| | | | | | | | nstv | | | | | | plgo | mago | enco | | | | | | | | | | | | | | | | | | | | |
| SP038 | SFNC6 | <table style="width: 100%; border-collapse: collapse; margin-bottom: 10px;"> <tr> <td style="text-align: center;">F</td><td style="text-align: center;">E</td><td style="text-align: center;">D</td><td style="text-align: center;">C</td><td style="text-align: center;">B</td><td style="text-align: center;">A</td><td style="text-align: center;">9</td><td style="text-align: center;">8</td><td style="text-align: center;">7</td><td style="text-align: center;">6</td><td style="text-align: center;">5</td><td style="text-align: center;">4</td><td style="text-align: center;">3</td><td style="text-align: center;">2</td><td style="text-align: center;">1</td><td style="text-align: center;">0</td> </tr> <tr> <td style="border: 1px solid black; width: 20px; text-align: center;">open</td><td style="border: 1px solid black; width: 20px;"></td><td style="border: 1px solid black; width: 20px;"></td><td style="border: 1px solid black; width: 20px;"></td><td style="border: 1px solid black; width: 20px;"></td><td style="border: 1px solid black; width: 20px;"></td><td style="border: 1px solid black; width: 20px;"></td><td style="border: 1px solid black; width: 20px;"></td><td style="border: 1px solid black; width: 20px;"></td><td style="border: 1px solid black; width: 20px;"></td><td style="border: 1px solid black; width: 20px;"></td><td style="border: 1px solid black; width: 20px;"></td><td style="border: 1px solid black; width: 20px; text-align: center;">plg2</td><td style="border: 1px solid black; width: 20px;"></td><td style="border: 1px solid black; width: 20px;"></td><td style="border: 1px solid black; width: 20px; text-align: center;">alty</td> </tr> </table> <p>[alty] Deceleration stop during alarm (0: invalid/1: valid) .. Note, only during specific alarms</p> <p>[plg2] Semi-closed pulse output signal × 2 (0: invalid (1 time)/1: valid (2 times))</p> <p>[open] Open loop operation (0: invalid/1: valid)</p> | F | E | D | C | B | A | 9 | 8 | 7 | 6 | 5 | 4 | 3 | 2 | 1 | 0 | open | | | | | | | | | | | | plg2 | | | alty | HEX setting |
| F | E | D | C | B | A | 9 | 8 | 7 | 6 | 5 | 4 | 3 | 2 | 1 | 0 | | | | | | | | | | | | | | | | | | | | |
| open | | | | | | | | | | | | plg2 | | | alty | | | | | | | | | | | | | | | | | | | | |

4. Status Display and Parameter Settings

| Name | Abbr. | Description | TYP | | | | | | | | | | | | | | | | | | | | | | | | | | | | | | | | |
|-------|-------|--|-----|---|---|------|------|---|------|------|---|------|------|------|------|---|---|---|------|------|------|--|--|--|------|------|--|------|------|--|------|------|------|------|-------------|
| SP097 | SPECO | <table style="width: 100%; border-collapse: collapse; margin-bottom: 10px;"> <tr> <td style="width: 5%;">F</td><td style="width: 5%;">E</td><td style="width: 5%;">D</td><td style="width: 5%;">C</td><td style="width: 5%;">B</td><td style="width: 5%;">A</td><td style="width: 5%;">9</td><td style="width: 5%;">8</td><td style="width: 5%;">7</td><td style="width: 5%;">6</td><td style="width: 5%;">5</td><td style="width: 5%;">4</td><td style="width: 5%;">3</td><td style="width: 5%;">2</td><td style="width: 5%;">1</td><td style="width: 5%;">0</td> </tr> <tr> <td style="border: 1px solid black;"></td><td style="border: 1px solid black;"></td><td style="border: 1px solid black;"></td><td style="border: 1px solid black;"></td><td style="border: 1px solid black;"></td><td style="border: 1px solid black;"></td><td style="border: 1px solid black;"></td><td style="border: 1px solid black;"></td><td style="border: 1px solid black;"></td><td style="border: 1px solid black;">mdir</td><td style="border: 1px solid black;">fdir</td><td style="border: 1px solid black;"></td><td style="border: 1px solid black;">pyfx</td><td style="border: 1px solid black;">dmin</td><td style="border: 1px solid black;">odi2</td><td style="border: 1px solid black;">odi1</td> </tr> </table> <p>Orientation control</p> <p>[odi2, odi1] Orientation rotation direction</p> <p>0 0 Pre (Orientation in rotating direction during speed control)</p> <p>0 1 Orientation from motor forward run direction</p> <p>1 1 Orientation from motor reverse run direction</p> <p>1 1 (Inhibit)</p> <p>[dmin] Dummy in-position (0: invalid/1: valid)</p> <p>[pyfx] Excitation fixed during orientation servo lock (0: invalid/1: valid)</p> <p>[fdir] Encoder detector polarity (0:(+)/1:(-))</p> <p>[mdir] Magnesensor detector polarity (0:(+)/1:(-))</p> | F | E | D | C | B | A | 9 | 8 | 7 | 6 | 5 | 4 | 3 | 2 | 1 | 0 | | | | | | | | | | mdir | fdir | | pyfx | dmin | odi2 | odi1 | HEX setting |
| F | E | D | C | B | A | 9 | 8 | 7 | 6 | 5 | 4 | 3 | 2 | 1 | 0 | | | | | | | | | | | | | | | | | | | | |
| | | | | | | | | | mdir | fdir | | pyfx | dmin | odi2 | odi1 | | | | | | | | | | | | | | | | | | | | |
| SP129 | SPECC | <table style="width: 100%; border-collapse: collapse; margin-bottom: 10px;"> <tr> <td style="width: 5%;">F</td><td style="width: 5%;">E</td><td style="width: 5%;">D</td><td style="width: 5%;">C</td><td style="width: 5%;">B</td><td style="width: 5%;">A</td><td style="width: 5%;">9</td><td style="width: 5%;">8</td><td style="width: 5%;">7</td><td style="width: 5%;">6</td><td style="width: 5%;">5</td><td style="width: 5%;">4</td><td style="width: 5%;">3</td><td style="width: 5%;">2</td><td style="width: 5%;">1</td><td style="width: 5%;">0</td> </tr> <tr> <td style="border: 1px solid black;">zrtn</td><td style="border: 1px solid black;">ptyp</td><td style="border: 1px solid black;">fb9x</td><td style="border: 1px solid black;"></td><td style="border: 1px solid black;"></td><td style="border: 1px solid black;"></td><td style="border: 1px solid black;">zdir</td><td style="border: 1px solid black;">ztyp</td><td style="border: 1px solid black;"></td><td style="border: 1px solid black;"></td><td style="border: 1px solid black;">fdir</td><td style="border: 1px solid black;"></td><td style="border: 1px solid black;">pyfx</td><td style="border: 1px solid black;"></td><td style="border: 1px solid black;"></td><td style="border: 1px solid black;"></td> </tr> </table> <p>C-axis control</p> <p>[pyfx] Position loop excitation fixing (0: invalid/1: valid)</p> <p>[fdir] Position detector polarity (0:(+)/1:(-))</p> <p>[ztyp] Z-phase detection type (0: standard/1: special)</p> <p>[zdir] Z-phase detection polarity (0: start up fixed/1: fall fixed) (Valid only when ztyp=1)</p> <p>[fb9x] Speed feedback during C-axis (0: PLG ... OSE 90K/1: 90,000 pulse detector ... MBE90K, MHE90K)</p> <p>[ptyp] Position control changeover type (0: after zero point return/1: after deceleration stop)</p> <p>[zrtn] Zero point return direction (0:CCW/1:CW)</p> | F | E | D | C | B | A | 9 | 8 | 7 | 6 | 5 | 4 | 3 | 2 | 1 | 0 | zrtn | ptyp | fb9x | | | | zdir | ztyp | | | fdir | | pyfx | | | | HEX setting |
| F | E | D | C | B | A | 9 | 8 | 7 | 6 | 5 | 4 | 3 | 2 | 1 | 0 | | | | | | | | | | | | | | | | | | | | |
| zrtn | ptyp | fb9x | | | | zdir | ztyp | | | fdir | | pyfx | | | | | | | | | | | | | | | | | | | | | | | |

4. Status Display and Parameter Settings

| Name | Abbr. | Description | TYP | | | | | | | | | | | | | | | | | | | | | | | | | | | | | | | | |
|-------|-------|--|-----|---|---|---|---|---|---|------|------|------|---|------|------|---|---|---|------|------|-----|--|--|--|--|--|--|--|------|------|------|--|------|------|-------------|
| SP177 | SPECS | <table border="1" style="width: 100%; text-align: center; border-collapse: collapse;"> <tr> <td>F</td><td>E</td><td>D</td><td>C</td><td>B</td><td>A</td><td>9</td><td>8</td><td>7</td><td>6</td><td>5</td><td>4</td><td>3</td><td>2</td><td>1</td><td>0</td> </tr> <tr> <td></td><td></td><td>odl</td><td></td><td></td><td></td><td></td><td></td><td></td><td></td><td>fdir</td><td></td><td>pyfx</td><td></td><td>adin</td><td>fclx</td> </tr> </table> <p>Spindle synchronous control</p> <p>[fclx] Semi-closed loop control (0: invalid/1: valid)</p> <p>[adin] Insertion compensation (0: invalid/1: valid) .. Note, valid only when gear ratio 1:1</p> <p>[pyfx] Position loop excitation fixing (0: invalid/1: valid)</p> <p>[fdir] Position detector polarity (0:(+)/1:(-))</p> <p>[odl] Excessive error width magnification (0: 1 time/1: 8 times)</p> | F | E | D | C | B | A | 9 | 8 | 7 | 6 | 5 | 4 | 3 | 2 | 1 | 0 | | | odl | | | | | | | | fdir | | pyfx | | adin | fclx | HEX setting |
| F | E | D | C | B | A | 9 | 8 | 7 | 6 | 5 | 4 | 3 | 2 | 1 | 0 | | | | | | | | | | | | | | | | | | | | |
| | | odl | | | | | | | | fdir | | pyfx | | adin | fclx | | | | | | | | | | | | | | | | | | | | |
| SP193 | SPECT | <table border="1" style="width: 100%; text-align: center; border-collapse: collapse;"> <tr> <td>F</td><td>E</td><td>D</td><td>C</td><td>B</td><td>A</td><td>9</td><td>8</td><td>7</td><td>6</td><td>5</td><td>4</td><td>3</td><td>2</td><td>1</td><td>0</td> </tr> <tr> <td>zrtn</td><td>ptyp</td><td>odl</td><td></td><td></td><td></td><td></td><td></td><td></td><td></td><td>fdir</td><td>cdir</td><td>pyfx</td><td></td><td>adin</td><td>fclx</td> </tr> </table> <p>Synchronous tap control</p> <p>[fclx] Semi-closed loop control (0: invalid/1: valid)</p> <p>[adin] Insertion compensation (0: invalid/1: valid) .. Note, valid only when gear ratio 1:1</p> <p>[pyfx] Position loop excitation fixing (0: invalid/1: valid)</p> <p>[cdir] Command polarity (0:CCW/1:CW)</p> <p>[fdir] Position detector polarity (0:(+)/1:(-))</p> <p>[odl] Excessive error width magnification (0: 1 time/1: 8 times)</p> <p>[ptyp] Position control changeover type (0: after zero point return/1: after deceleration stop)</p> <p>[zrtn] Zero point return direction (0:CCW/1:CW)</p> | F | E | D | C | B | A | 9 | 8 | 7 | 6 | 5 | 4 | 3 | 2 | 1 | 0 | zrtn | ptyp | odl | | | | | | | | fdir | cdir | pyfx | | adin | fclx | HEX setting |
| F | E | D | C | B | A | 9 | 8 | 7 | 6 | 5 | 4 | 3 | 2 | 1 | 0 | | | | | | | | | | | | | | | | | | | | |
| zrtn | ptyp | odl | | | | | | | | fdir | cdir | pyfx | | adin | fclx | | | | | | | | | | | | | | | | | | | | |

4. Status Display and Parameter Settings

(3) Motor type and power supply type selection parameters

| Motor type | | | | Power supply type | |
|--|------------------|------------|-------------------------|--|-------------------|
| SP040 (MTYP) | | | | SP041 (PTYP) | |
| Parameter setting | Motor model name | Max. speed | Corresponding amplifier | Parameter setting | Power supply type |
| 0000 | | | | 0000 | Not connected |
| 0001 | SJ-2.2A | 10000r/min | SP-22 | 0004 | CV-37 |
| 0002 | SJ-3.7A | 10000r/min | SP-37 | 0006 | CV-55 |
| 0003 | SJ-5.5A | 8000r/min | SP-55 | 0008 | CV-75 |
| 0004 | SJ-7.5A | 8000r/min | SP-75 | 0011 | CV-110 |
| 0005 | SJ-11A | 6000r/min | SP-110 | 0015 | CV-150 |
| 0006 | SJ-15A | 6000r/min | SP-150 | 0019 | CV-185 |
| 0007 | SJ-18.5A | 6000r/min | SP-185 | 0022 | CV-220 |
| 0008 | SJ-22A | 4500r/min | SP-220 | 0026 | CV-260 |
| 0009 | SJ-26A | 4500r/min | SP-260 | 0030 | CV-300 |
| 000A | SJ-30A | 4500r/min | SP-300 | | |
| 000B | | | | | |
| 000C | | | | | |
| 000D | | | | | |
| 000E | | | | | |
| 000F | | | | | |
| 0010 | | | | | |
| 0011 | SJ-N0.75A | 10000r/min | SP-075 | | |
| 0012 | SJ-N1.5A | 10000r/min | SP-15 | | |
| 0013 | SJ-N2.2A | 10000r/min | SP-22 | | |
| 0014 | SJ-N3.7A | 10000r/min | SP-37 | | |
| 0015 | SJ-N5.5A | 8000r/min | SP-55 | | |
| 0016 | SJ-N7.5A | 8000r/min | SP-75 | | |
| 0017 | | | | | |
| 0018 | | | | | |
| 0019 | | | | | |
| 001A | | | | | |
| 001B | SJ-J2.2A | 10000r/min | SP-22 | | |
| 001C | SJ-J3.7A | 10000r/min | SP-37 | | |
| 001D | SJ-J5.5A | 8000r/min | SP-55 | | |
| 001E | SJ-J7.5A | 8000r/min | SP-75 | | |
| 001F | | | | | |
| <p>(Note) The above motor selection is valid only when SP034 (SFNC2) -bit0 is set to 0.</p> | | | | <p>(Note) When using external emergency stop with MDS-B-CV, add 40 to the above setting value and set.</p> <p>Example) When using external emergency stop with CV-260: The setting is 0026 + 0040 = 0066</p> | |

4. Status Display and Parameter Settings

(4) D/A output function

- 1) Outline
The MDS-A-SP and MDS-B-SP has a D/A output function in the standard system.
The drive unit state and each data can be confirmed with this D/A output function.
- 2) Hardware specifications
 - 2 channel
 - 8 bits 0 to +10V
 - Output pins

| | |
|---|---------------------|
| { | CH1 : CN9-9 pins |
| | CH2 : CN9-19 pins |
| | GND : CN9-1.11 pins |
- 3) Parameters
Set the data No. and output magnification for each channel with the following parameters.

| No. | Abbr. | Name |
|-------|--------|---------------------------------|
| SP253 | DA1NO | DA channel 1 data No. |
| SP254 | DA2NO | DA channel 2 data No. |
| SP255 | DA1MPY | DA channel 1 data magnification |
| SP256 | DA2MPY | DA channel 2 data magnification |

- 4) Data output No.
Set the No. of the data to be D/A output in SP253 and SP254.
The output data and data No. correspondence is shown below.

| No. (=parameter setting value) | CH1 | | CH2 | |
|--------------------------------------|----------------------------------|--|----------------------|---------------------|
| | Output data | Unit | Output data | Unit |
| 0 | Speedometer output | Max. speed at 10V | Load meter output | 120% load at 10V |
| 2 | Current command | 100% conversion when actual data = 4096 | Same as CH1 | |
| 3 | Current feedback | 100% conversion when actual data = 4096 | | |
| 4 | Speed feedback | Actual data r/min | | |
| 6 | Position droop low-order | Interpolation unit | | |
| 7 | Position droop high-order | (360° conversion when actual data = 23040000.) | | |
| 8 | Position F Δ t low-order | Interpolation unit | | |
| 9 | Position F Δ t high-order | Interpolation unit/NC communication cycle | | |
| 10 | Position command low-order | Interpolation unit | | |
| 11 | Position command high-order | (360° conversion when actual data = 23040000.) | | |
| 12 | Feedback position low-order | Interpolation unit | | |
| 13 | Feedback position high-order | (360° conversion when actual data = 23040000.) | | |
| 80 | Control input 1 | Corresponding to bit | | |
| 81 | Control input 2 | | | |
| 82 | Control input 3 | | | |
| 83 | Control input 4 | | | |
| 84 | Control output 1 | Corresponding to bit | | |
| 85 | Control output 2 | | | |
| 86 | Control output 3 | | | |
| 87 | Control output 4 | | | |

(Note) The current command and current feedback % refers to 30 min. rating = 100%.

4. Status Display and Parameter Settings

5) Setting of output magnification

The output magnification of the data to be D/A output is set in SP255 and SP256.

If,

$$\text{DATA} = \text{actual data} \times \frac{\text{SP255 or SP256}}{256}$$

- ① The output data other than speedometer output and load meter output will be D/A output as shown in Fig. 1.
- ② The speedometer output and load meter output data will be D/A output as shown in Fig. 2.

D/A output voltage

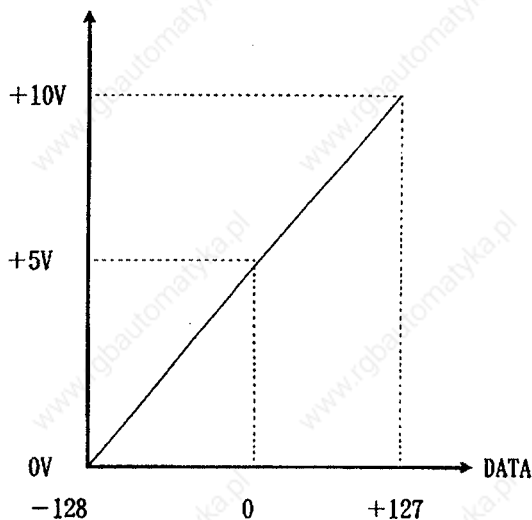

Fig. 1

D/A output voltage

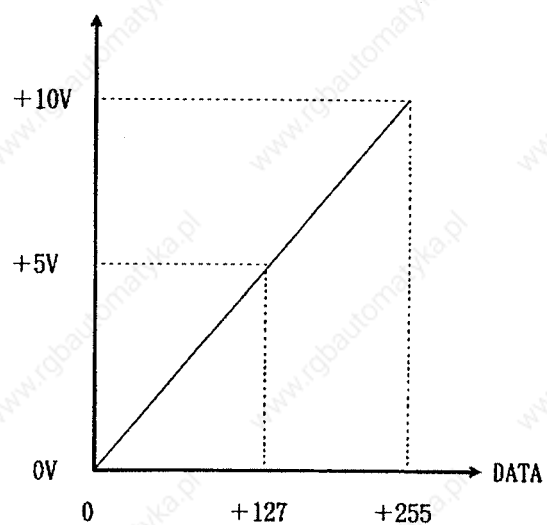

Fig. 2

(Example 1) Current command, current feedback.

The data unit is 100% conversion when the actual data = 4096.

Thus, the actual data = $4096 \times 1.2 = 4915$ will be output when the current feedback is +120%. If parameter SP255 (SP256) is set to 256 (magnification = 1), the D/A output voltage will be the following, according to Fig. 1.

$$\text{D/A output voltage} = 5V + \{4915 \times 1 \times (5V/128)\} = 197V > 10V$$

Thus, the D/A output voltage maximum value will be exceeded.

In this case, if parameter SP255 (SP256) is set to 6, the D/A output voltage will be as follows:

$$\text{D/A output voltage} = 5V + \{4915 \times 6/256 \times (5V/128)\} = 9.5V > 10V$$

Thus, the data can be confirmed.

(Example 2) Speed feedback

The data unit is r/min (rpm).

Thus, at a motor rotation of +2000r/min, the actual data = 2000 will be output.

If parameter SP255 (SP256) is set to 256 (magnification = 1), the D/A output voltage will be the following, according to Fig. 1.

$$\text{D/A output voltage} = 5V + \{2000 \times 1 \times (5V/128)\} = 83.125V > 10V$$

Thus, the D/A output voltage maximum value will be exceeded.

In this case, if parameter SP255 (SP256) is set to 16, the D/A output voltage will be as follows:

$$\text{D/A output voltage} = 5V + \{2000 \times 16/256 \times (5V/128)\} = 9.88V > 10V$$

Thus, the data can be confirmed.

4. Status Display and Parameter Settings

(Example 3) Position droop

The data unit is 360° conversion when the actual data = 23040000.

Thus, during a +0.1° position droop, the actual data = $0.1 \times 23040000/360=6400$ will be output. If parameter SP255 (SP256) is set to 256 (magnification = 1), the D/A output voltage will be the following, according to Fig. 1.

$$\text{D/A output voltage} = 5V + \{6400 \times 1 \times (5V/128)\} = 255V > 10V$$

Thus, the D/A output voltage maximum value will be exceeded.

In this case, if parameter SP255 (SP256) is set to 5, the D/A output voltage will be as follows:

$$\text{D/A output voltage} = 5V + \{6400 \times 5/256 \times (5V/128)\} = 9.88V > 10V$$

Thus, the data can be confirmed.

(Example 4) To confirm the orientation complete signal (ORCF) at control output 4L.

The data unit is data corresponding to bits.

Refer to section 4.4 for the meanings of the control output 4L bit corresponding signals.

The orientation complete signal (ORCF) corresponds to bit 4 of control output 4L.

Thus, if ORCF is ON, the actual data = $2^4 = 16$ corresponding to bit 4 will be output.

If parameter SP255 (SP256) is set to 256 (magnification = 1), the D/A output voltage will be the following, according to Fig. 1.

$$\text{D/A output voltage} = 5V + \{16 \times 1 \times (5V/128)\} = 5.625V > 10V$$

Thus, the data can be confirmed.

However, if a bit other than bit 4 is ON, the voltage of that bit will be added to 6.25V above, so when measuring the actual ORCF signal, it is confirmed with the $(5.625V-5V) = 0.625V$ changed voltage.

4. Status Display and Parameter Settings

4.3 Spindle specification parameters screen

The spindle parameters are divided into those transmitted to the spindle drive unit from the NC and those used on the NC side.

(1) Parameters transmitted to the spindle drive unit from the NC

The 384 parameters shown in section 4.2.(1) are those transmitted from the NC to the spindle drive unit.

(2) Parameters used on NC side

The spindle specifications parameters shown on this page are used on the NC side.

[SP-NC PARAM]

| # | | | | | |
|----|--------|------|----|----------|------|
| 1 | slimt1 | 320 | 17 | stapt1 | 110 |
| 2 | 2 | 790 | 18 | 2 | 510 |
| 3 | 3 | 4000 | 19 | 3 | 1200 |
| 4 | 4 | 0 | 20 | 4 | 0 |
| 5 | smax 1 | 320 | 21 | sori | 0 |
| 6 | 2 | 790 | 22 | sgear | 0 |
| 7 | 3 | 4000 | 23 | smini | 100 |
| 8 | 4 | 0 | 24 | serr | 0 |
| 9 | ssift1 | 0 | 25 | sname | 0 |
| 10 | 2 | 0 | 26 | | |
| 11 | 3 | 0 | 27 | senc_pno | 0 |
| 12 | 4 | 0 | 28 | sana_pno | 0 |
| 13 | stap 1 | 250 | 29 | spfig | 0 |
| 14 | 2 | 527 | 30 | senc_no | 0 |
| 15 | 3 | 2640 | 31 | sana_no | 0 |
| 16 | 4 | 0 | 32 | smcp_no | 0 |

#() DATA ()

| No. | Item | Description | Setting range (unit) | |
|-----|---------|--------------------|---|--|
| 1 | slimt 1 | Speed limit | For GEAR 00 } GEAR 01 } spindle speed with motor at maximum speed GEAR 10 } is set. GEAR 11 } | 0 ~ 99999 (r/min) |
| 2 | 2 | | | |
| 3 | 3 | | | |
| 4 | 4 | | | |
| 5 | smax 1 | Max. speed | For GEAR 00 } GEAR 01 } maximum spindle speed is set. GEAR 10 } Set slimt ≥ smax. GEAR 11 } | 0 ~ 99999 (r/min) |
| 6 | 2 | | | |
| 7 | 3 | | | |
| 8 | 4 | | | |
| 9 | ssift 1 | Shift speed | For GEAR 00 } GEAR 01 } spindle speed for gear shift is set. GEAR 10 } GEAR 11 } | 0 ~ 32767 (r/min) |
| 10 | 2 | | | |
| 11 | 3 | | | |
| 12 | 4 | | | |
| 13 | stap 1 | Tap speed | For GEAR 00 } GEAR 01 } maximum spindle speed during constant GEAR 10 } inclination tap cycle is set. GEAR 11 } | 0 ~ 99999 (r/min) |
| 14 | 2 | | | |
| 15 | 3 | | | |
| 16 | 4 | | | |
| 17 | stapt 1 | Tap time constant | For GEAR 00 } GEAR 01 } the time constant to the maximum tap speed GEAR 10 } during constant inclination tap cycle is set. GEAR 11 } | 0 ~ 5000 (msec) |
| 18 | 2 | | | |
| 19 | 3 | | | |
| 20 | 4 | | | |
| 22 | sgear | Encoder gear ratio | Gear ratio between spindle gear and encoder gear is set. | 0 : 1/1 1 : 1/2 2 : 1/4 3 : 1/8 |
| 23 | smini | Min. speed | The min. spindle speed is set. Even if an S-command lower than this value is input, the spindle will rotate at this speed. | 0 ~ 32767 (r/min) |

4. Status Display and Parameter Settings

4.4 Spindle monitor screen

The current state of the spindle can be confirmed on the NC screen.
The monitor screen is shown on this page.

| [SPINDLE MONITOR] | | | | | | |
|-------------------|--------|-----|----|----------|--------------|----------|
| GAIN (1/sec) | 0 | D/I | 1L | 00000000 | UNIT TYP | 00000000 |
| DROOP (i) | 160 | | H | 00000000 | UNIT NO | 00000000 |
| SPEED (rpm) | 0 | | 2L | 00000000 | S/W VER | 00000000 |
| LOAD (%) | 0 | | H | 00000000 | 1 WORK TIME | 00000000 |
| AMP DISP | D4 | | 3L | 00000000 | 2 ALM HIST 1 | 00000000 |
| ALARM | | | H | 00000000 | 2 | 00000000 |
| CYC CNT (P) | -10240 | | 4L | 00000000 | 3 | 00000000 |
| | | | H | 00000000 | 4 | 00000000 |
| | | | | | 5 | 00000000 |
| | | D/O | 1L | 00000000 | 6 | 00000000 |
| | | | H | 00000000 | 7 | 00000000 |
| | | | 2L | 00000000 | 8 | 00000000 |
| | | | H | 00000000 | | |
| | | | 3L | 00000000 | MNT | 00000000 |
| | | | H | 00000000 | /SYS | 00000000 |
| | | | 4L | 00000000 | | |
| | | | H | 00000000 | | |

| Data | Unit | Display details |
|----------------|--------|--|
| GAIN | 1/sec. | The position loop gain during operation of the spindle with the position command is display. |
| DROOP | pulse | The position deflection during operation of the spindle with the position command is displayed. |
| SPEED | rpm | The motor speed is displayed. |
| LOAD | % | The motor load (load ratio) is displayed. The 30 min. rating is 100%. |
| AMP DISP | | The data of the 7-segment display for the spindle drive unit is displayed. |
| ALARM | | The alarm No. is displayed when an alarm other than that displayed on the spindle drive unit's 7-segment LED. |
| CYC CNT | | The current position from the position detector's reference position (Z-phase) when operating the spindle with the position command is displayed. |
| D/I 1L H | | The control input signal 1 input from the NC to the spindle drive unit is displayed in correspondence to the bits. (Refer to section (1-1) for details.) |
| D/I 2L H | | Same as above (control input signal 2) |
| D/I 3L H | | Same as above (control input signal 3) |
| D/I 4L H | | Same as above (control input signal 4) |
| D/O 1L H | | The control output signal 1 output from the spindle drive unit to the NC is displayed in correspondence to the bits. (Refer to section (2-1) for details.) |
| D/O 2L H | | Same as above (control output signal 2) |
| D/O 3L H | | Same as above (control output signal 3) |
| D/O 4L H | | Same as above (control output signal 4) |
| UNIT TYP | | The spindle drive unit type is displayed. |
| UNIT NO | | The spindle drive unit manufacturing No. is displayed. |
| S/W VER | | The main software version in the spindle drive unit is displayed. |
| 1 WORK TIME | | The cumulative working time of the spindle drive unit is displayed. |
| 2 ALM HIST 1~8 | | The alarm history is displayed. 1 is the latest alarm. |

4. Status Display and Parameter Settings

(1-1) D/I (Control input) 1L

H

| | | | | | | | | | | | | | | | |
|----|---|---|---|-----|-----|-----|------|-----|---|---|---|---|---|-----|-----|
| F | E | D | C | B | A | 9 | 8 | 7 | 6 | 5 | 4 | 3 | 2 | 1 | 0 |
| G1 | | | | TL3 | TL2 | TL1 | ALMR | PRM | | | | | | SRV | RDY |

| bit | Name | Description |
|-----|------|------------------------------|
| 0 | RDY | Ready ON command |
| 1 | SRV | Servo ON command |
| 2 | | |
| 3 | | |
| 4 | | |
| 5 | | |
| 6 | PRM | Parameter conversion command |
| 7 | ALMR | Servo alarm reset command |
| 8 | TL1 | Torque limit 1 |
| 9 | TL2 | Torque limit 2 |
| A | TL3 | Torque limit 3 |
| B | | |
| C | | |
| D | | |
| E | | |
| F | G1 | Cutting |

(1-2) D/I (Control input) 2L

H

| | | | | | | | | | | | | | | | |
|---|---|---|---|---|---|---|---|---|---|---|---|---|---|---|---|
| F | E | D | C | B | A | 9 | 8 | 7 | 6 | 5 | 4 | 3 | 2 | 1 | 0 |
| | | | | | | | | | | | | | | | |

* Not used at this time.

(1-3) D/I (Control input) 3L

H

| | | | | | | | | | | | | | | | |
|---|----|-----|-----|-----|-----|-----|-----|-----|-----|-----|-----|-----|-----|-----|-----|
| F | E | D | C | B | A | 9 | 8 | 7 | 6 | 5 | 4 | 3 | 2 | 1 | 0 |
| | MS | LCS | ORC | WRI | WRN | SRI | SRN | GR3 | GR2 | GR1 | SC5 | SC4 | SC3 | SC2 | SC1 |

| bit | Name | Description |
|-----|------|---|
| 0 | SC1 | Spindle control mode selection command 1 |
| 1 | SC2 | Spindle control mode selection command 2 |
| 2 | SC3 | Spindle control mode selection command 3 |
| 3 | SC4 | Spindle control mode selection command 4 |
| 4 | SC5 | Spindle control mode selection command 5 |
| 5 | GR1 | Gear selection command 1 |
| 6 | GR2 | Gear selection command 2 |
| 7 | GR3 | Gear selection command 3 |
| 8 | SRN | Forward run start command |
| 9 | SRI | Reverse run start command |
| A | WRN | Index forward run command |
| B | WRI | Index reverse run command |
| C | ORC | Orient start command |
| D | LCS | L coil selection command (during coil changeover) |
| E | MS | Sub-motor selection command (during 1-amplifier 2-motor changeover) |
| F | | |

4. Status Display and Parameter Settings

(1-4) D/I (Control input) 4L H

| | | | | | | | | | | | | | | | |
|---|---|---|---|---|---|---|---|---|---|---|---|---|---|---|---|
| F | E | D | C | B | A | 9 | 8 | 7 | 6 | 5 | 4 | 3 | 2 | 1 | 0 |
| | | | | | | | | | | | | | | | |

* Not used at this time.

(2-1) D/O (Control output) 1L H

| | | | | | | | | | | | | | | | |
|---|-----|------|---|---|------|------|------|-----|-----|---|-----|---|---|-----|-----|
| F | E | D | C | B | A | 9 | 8 | 7 | 6 | 5 | 4 | 3 | 2 | 1 | 0 |
| | INP | ZFIN | | | TL3A | TL2A | TL1A | ALM | PRM | | WRN | | | SON | RON |

| bit | Name | Description |
|-----|------|------------------------------|
| 0 | RON | In ready ON |
| 1 | SON | In servo ON |
| 2 | | |
| 3 | | |
| 4 | WRN | In drive unit warning |
| 5 | | |
| 6 | | |
| 7 | ALM | In alarm |
| 8 | TL1A | In torque limit 1 |
| 9 | TL2A | In torque limit 2 |
| A | TL3A | In torque limit 3 |
| B | | |
| C | | |
| D | ZFIN | Z-phase passed |
| E | INP | In position loop in-position |
| F | | |

(2-2) D/O (Control output) 2L H

| | | | | | | | | | | | | | | | |
|---|---|---|---|---|---|---|---|---|---|---|---|---|---|---|---|
| F | E | D | C | B | A | 9 | 8 | 7 | 6 | 5 | 4 | 3 | 2 | 1 | 0 |
| | | | | | | | | | | | | | | | |

* Not used at this time.

4. Status Display and Parameter Settings

(2-3) D/O (Control output) 3L

H

| | | | | | | | | | | | | | | | |
|---|-----|------|------|------|------|------|------|------|------|------|------|------|------|------|------|
| F | E | D | C | B | A | 9 | 8 | 7 | 6 | 5 | 4 | 3 | 2 | 1 | 0 |
| | MSA | LCSA | ORCA | WRIA | WRNA | SRIA | SRNA | GR3A | GR2A | GR1A | SC5A | SC4A | SC3A | SC2A | SC1A |

| bit | Name | Description |
|-----|------|--|
| 0 | SC1A | In spindle control mode selection command 1 |
| 1 | SC2A | In spindle control mode selection command 2 |
| 2 | SC3A | In spindle control mode selection command 3 |
| 3 | SC4A | In spindle control mode selection command 4 |
| 4 | SC5A | In spindle control mode selection command 5 |
| 5 | GR1A | In gear selection command 1 |
| 6 | GR2A | In gear selection command 2 |
| 7 | GR3A | In gear selection command 3 |
| 8 | SRNA | In forward run start command |
| 9 | SRIA | In reverse run start command |
| A | WRNA | In index forward run command |
| B | WRIA | In index reverse run command |
| C | ORCA | In orientation start command |
| D | LCSA | In L coil selection command (during coil changeover) |
| E | MSA | In sub-motor selection command (during 1-amplifier 2-motor changeover) |
| F | | |

(2-4) D/O (Control output) 4L

H

| | | | | | | | | | | | | | | | |
|---|---|---|---|---|---|---|---|------|-----|------|------|----|----|----|----|
| F | E | D | C | B | A | 9 | 8 | 7 | 6 | 5 | 4 | 3 | 2 | 1 | 0 |
| | | | | | | | | WRCF | MKC | SYSA | ORCF | ZS | US | SD | CD |

| bit | Name | Description |
|-----|------|----------------------------|
| 0 | CD | Current detection |
| 1 | SD | Speed detection |
| 2 | US | Speed reached |
| 3 | ZS | Zero speed |
| 4 | ORCF | Orientation complete |
| 5 | SYSA | Synchronous speed match |
| 6 | MKC | In coil changeover |
| 7 | WRCF | Index positioning complete |
| 8 | | |
| 9 | | |
| A | | |
| B | | |
| C | | |
| D | | |
| E | | |
| F | | |

4. Status Display and Parameter Settings

4.5 Alarm and warning table

| Alarm No. | Abbr. | Name | Details | Operation (Note) |
|-----------|-------|-----------------------------|--|------------------|
| 12 | ME1 | Memory error 1 | A check sum or RAM check error occurred in the spindle drive control card ROM. | PR |
| 13 | SWE | Software process error | The software data process did not end within the set time. | PR |
| 17 | ADE | AD error | The current detection AD converter did not function correctly during initialization. | PR |
| 21 | NS2 | No signal (spindle encoder) | The signal was not input from the spindle encoder (for orientation, C axis), or was not at the normal level. | PR |
| 23 | OSE | Excessive speed deflection | The speed command and motor speed deflection exceeded the specified value and the state continued for a specified time. | PR |
| 31 | OS | Overspeed | The motor speed exceeded 115% of the set max. speed. | PR |
| 32 | PMOC | Power module overcurrent | A current exceeding the set value flowed into the IPM used in the spindle drive's main circuit. | PR |
| 34 | DP | CRC error | A CRC error occurred in the communication data from the NC. | PR |
| 35 | DE | Data error | The movement command from the NC was excessively large during position control. | PR |
| 36 | TE | Transmission error | The periodic data transmission from the NC was terminated. | PR |
| 37 | PE | Parameter error | A parameter value exceeding the tolerable value was set. | PR |
| 38 | TP1 | Protocol error 1 | There was a protocol error in the communication with the NC. (Frame error) | PR |
| 39 | TP2 | Protocol error 2 | There was a protocol error in the communication with the NC. (Information error) | PR |
| 3B | PMOH | Power module overheat | Overheating of the IPM used in the servo drive's main circuit was detected. | PR |
| 40 | KE1 | TK unit change error | The changeover signal procedure was incorrect when using the TK unit. | PR |
| 41 | KE2 | TK unit communication error | The communication with the TK unit was not correct when using the TK unit. | PR |
| 44 | CAXE | C axis changeover alarm | When using the coil changeover motor, the C axis was controlled with the H coil. | NR |
| 46 | OHM | Motor overheat | Overload, or the motor cooling blower stop and the motor overheated causing the built-in thermal protector to function. | NR |
| 50 | OL | Overload | The motor current flowed for a time exceeding the overload time constant of the overload detection level. | NR |
| 52 | OD | Excessive error | The position tracking error was over the specified value in the position loop operation. | NR |
| 5C | ORFE | Orientation feedback error | When the orientation in-position was completed, the pulse miss value was higher than the parameter setting value (SP114:OPER). | NR |
| 60~7F | - | — | An alarm occurred in the power supply. (Refer to the section on the power supply for details.) | - |
| 82 | NSP | Power supply no signal | Breakage or incorrect connection of the cable connected to the power supply was detected. | PR |
| E1 | WOL | Overload warning | The motor current flowed at 80% or more of the detection time constant for a time exceeding the overload detection level. | AR |
| E7 | NCE | NC emergency stop | The emergency stop command is input from the CNC. | PR |

Note) If the above protective functions activate, the alarm No. will be displayed on the 7-segment LED built into the spindle drive, and the following will occur.

- Operation PR : The base current of the spindle drive will be shut off, the external contactor will turn OFF, and the spindle motor will coast to a stop.
- Operation NR : The spindle motor will decelerate and stop with the regenerative braking, and then the base current will be shut off.
- Operation AR : Only a warning will display, and operation can be continued.

5. Optional Specifications and Parts

| |
|---|
|  WARNING |
| Always wait at least 10 minutes after turning the power OFF before connecting options or peripheral devices. Failure to observe this could lead to electric shocks. |

| |
|--|
|  CAUTION |
| Always use the designated peripheral devices and options. Failure to observe this could lead to faults or fires. |

5.1 Orientation specifications (optional)

The following three types of orientation specifications are available:

- (1) 1-point orientation using magnesensor
- (2) 4096-point orientation using encoder
- (3) 4096-point orientation using motor built-in encoder

5.1.1 1-point orientation using magnesensor

(1) Connection

Refer to "1.4 configuration" for the connection of the magnesensor and spindle drive unit.

(2) Magnet and detection head installation direction

The magnet and detection head should be installed in the specified orientation.

Standard type and high speed standard type

..... The center reference hole of magnet and the reference notch of detection head should come to the same side.

Refer to **CASE 1** , **CASE 2** , **CASE 3** and **UNACCEPTABLE EXAMPLE 1** .

High-speed small type

..... The reference notch of detection head should be positioned in reference with polarity (N, S) of magnet.

Refer to **CASE 4** , **CASE 5** and **UNACCEPTABLE EXAMPLE 2** .

High-speed ring type

..... The reference notch of detection head should be positioned in reference with polarity (N, S) of magnet.

Refer to **CASE 6** , **CASE 7** and **UNACCEPTABLE EXAMPLE 3** .

- CASE 1** Magnet is installed on the circumferential surface of rotating body. (Circumferential mounting)
 The reference hole of magnet and the reference notch of detection head should come to the opposite drive side, as shown below.

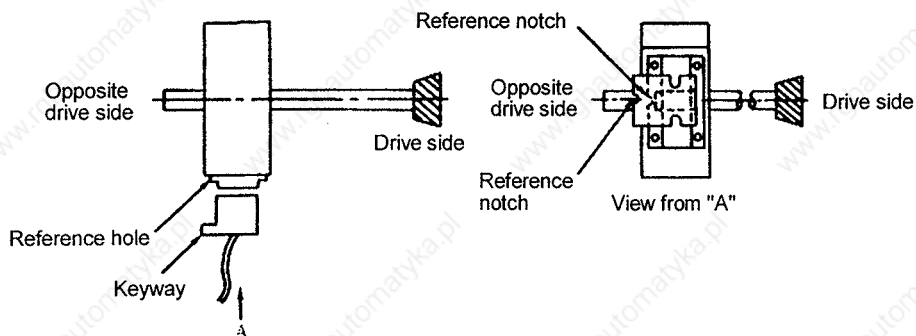

Magnet is installed on circumferential surface of rotating body.

5. Optional Specifications and Parts

CASE 2 Magnet is installed on the front or back flat surface of rotating disk. (Flat mounting)

(1) When the magnet is installed on the opposite drive side of spindle, the reference hole of magnet and reference notch of detection head should face inward, as shown below.

(2) When the magnet is installed on the drive side of spindle, the reference hole of magnet and reference notch of detection head should face outward, as shown below.

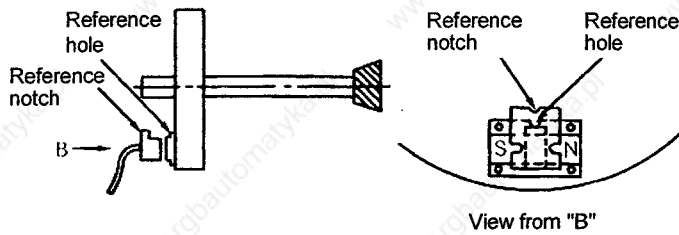

Magnet is installed on the opposite drive side.

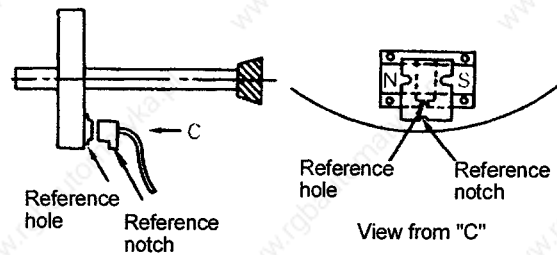

Magnet is installed on the drive side.

CASE 3 In regard to **CASE 1**, the magnet and detection head can be changed to the following position as long as the reference hole and reference notch are aligned. With this, normal orientation can be carried out. (However, the parameter SP097 orientation detector installation direction bit must be changed in this case.)

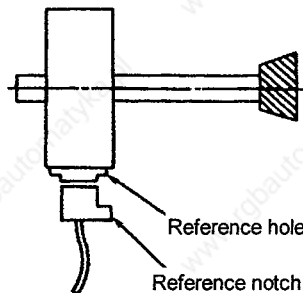

UNACCEPTABLE EXAMPLE 1

If the magnet reference hole and detection head reference notch are not aligned, intense vibration will occur when the detection head is at end of magnet, and orientation is impossible.

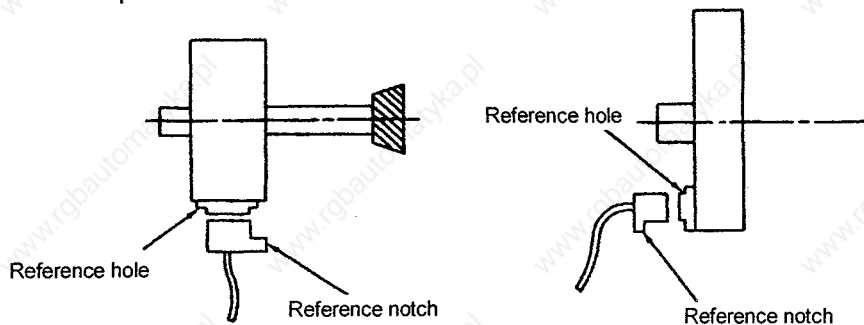

5. Optional Specifications and Parts

- CASE 4** Magnet is installed on the circumferential surface of rotating disk. (Circumferential mounting)
The detection head reference notch should be on the opposite drive side and the magnet should be installed in the polarity shown below.

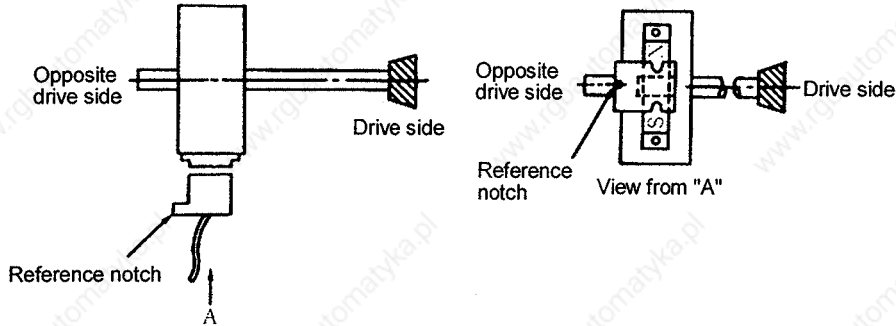

Magnet is installed on the circumferential surface of rotating disk.

- CASE 5** As long as the relation between location of the detection head reference notch and the polarity of the magnet are aligned, the detection head and the magnet can be installed as shown below in **CASE 4**, and normal orientation can be carried out.
(However, the parameter SP097 orientation detector installation direction bit must be changed in this case.)

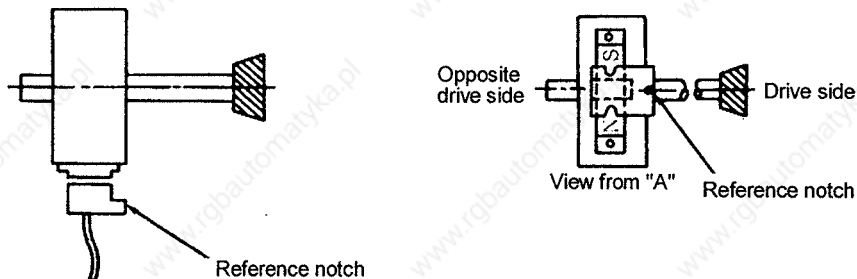

UNACCEPTABLE EXAMPLE 2

If the detection head reference notch is not aligned properly in reference to polarity of the magnet, intense vibration occurs when the detection head is at the end of the magnet, and orientation is impossible.

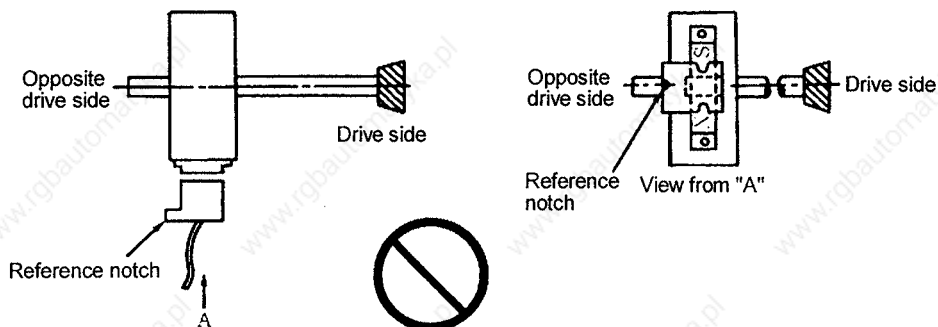

In this example, polarity (N, S) of magnet is inverse to that in **CASE 4**.

5. Optional Specifications and Parts

CASE 6 The sensor head reference notch is on the opposite drive side of spindle and the polarity of the magnet is as shown below.

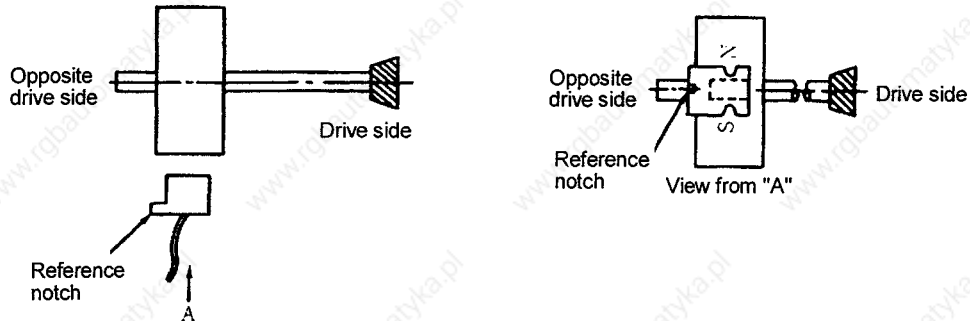

CASE 7 As long as the relation between location of sensor head reference notch and the polarity of the magnet are aligned, the sensor head and the magnet can be installed as shown below in **CASE 4**, and normal orientation can be carried out. (However, the parameter SP097 orientation detector installation direction bit must be changed in this case.)

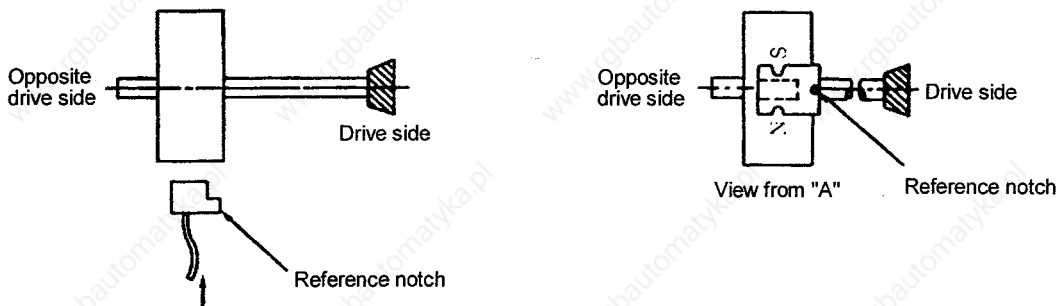

UNACCEPTABLE EXAMPLE 3

If the sensor head reference notch is not aligned properly in reference to polarity of the magnet, intense vibration occurs when the sensor head is at the end of the magnet, and orientation is impossible.

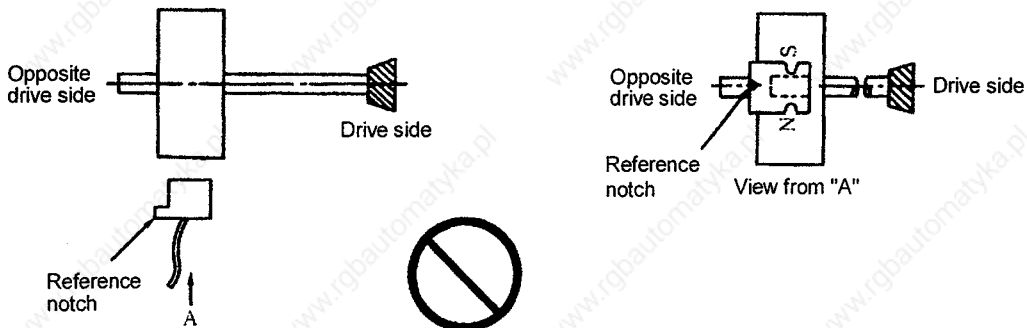

In this example, polarity (N, S) of magnet is inverse to that in **CASE 4**.

5. Optional Specifications and Parts

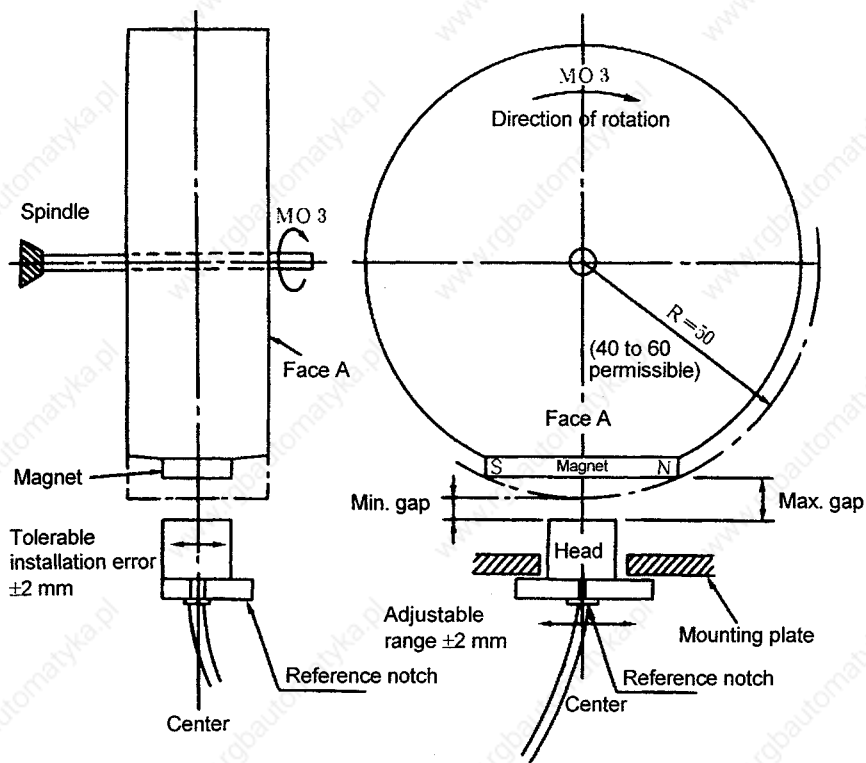

Table 1

| Radius (R) mm | BKO-C1810H03 | Standard | BKO-C1730H06 | High speed standard |
|---------------|--------------|-------------|--------------|---------------------|
| | Max. gap mm | Min. gap mm | Max. gap mm | Min. gap mm |
| 40 | 11.5 ± 0.5 | 2.7 ± 0.5 | 10 ± 0.5 | 1.22 ± 0.5 |
| 50 | 9.5 ± 0.5 | 2.8 ± 0.5 | 8 ± 0.5 | 1.31 ± 0.5 |
| 60 | 8.5 ± 0.5 | 3.0 ± 0.5 | 7 ± 0.5 | 1.5 ± 0.5 |
| 70 | 8.0 ± 0.5 | 3.4 ± 0.5 | 7 ± 0.5 | 2.38 ± 0.5 |

Table 2

| Radius (R) mm | BKO-C1810H03 | Standard | BKO-C1730H06 | High speed standard |
|---------------|--------------|----------|--------------|---------------------|
| | Gap mm | | Gap mm | |
| 40 | 6 ± 0.5 | | 5 ± 0.5 | |
| 50 | 6 ± 0.5 | | 5 ± 0.5 | |
| 60 | 6 ± 0.5 | | 5 ± 0.5 | |

Table 3

| Radius (R) mm | BKO-C1730H09 | High speed standard |
|---------------|--------------|---------------------|
| | Max. gap mm | Min. gap mm |
| 40 | 6.25 ± 0.5 | 3.3 ± 0.5 |
| 50 | 6.0 ± 0.5 | 3.7 ± 0.5 |
| 60 | 5.75 ± 0.5 | 3.85 ± 0.5 |
| 70 | 5.5 ± 0.5 | 3.87 ± 0.5 |

5. Optional Specifications and Parts

(3) Caution on installation of magnet

When the magnet is installed to the spindle, pay attention to the following:

- 1) Do not place an intense magnetic source near the magnet.
- 2) Carefully handle the magnet, avoiding mechanical shock to the magnet.
- 3) Secure the magnet to the spindle with M4 screws.
- 4) After the magnet is installed, balance the entire spindle.
- 5) Align the center of the magnet (between N and S) with the center line of the rotating disk on the spindle.

(The position relation should be as shown in **CASE 1** to **CASE 7** on the previous pages.)

- 6) Keep the magnet and its peripheral clean of from iron particles (iron particles may caused malfunction).
- 7) Apply lock paint, or other suitable means, to prevent installation screws from becoming loose.
- 8) If the magnet is installed on a ground rotating disk, demagnetize the disk.
- 9) Diameter of rotating disk on which the magnet is installed should be within the range from 80mm to 120mm.
- 10) If speed of the spindle on which the magnet is installed exceeds 6000r/min, use a high-speed type magnet (applicable up to 12000r/min of speed). If speed exceeds 12000r/min, use a ring type magnet.
- 11) When installing the magnet on a rotating body plane, keep the speed below 6,000r/min.

(4) Caution on installation of sensor

Observe the following cautions when installing the sensor.

- 1) The position relation of the magnet and sensor head should follow **CASE 1** to **CASE 7**.
- 2) The center line of sensor head should be in line with the center of magnet.
- 3) The gap between the magnet and sensor head should be as follows:
 - Table 1 on previous page when using standard magnet and installation **CASE 1** or **CASE 3**
 - Table 1 on previous page when using high-speed standard magnet and installation **CASE 1** or **CASE 3**
 - Table 2 on previous page when using standard magnet and installation **CASE 2**
 - Table 2 on previous page when using high-speed standard magnet and installation **CASE 2**
 - Table 3 on previous page when using high-speed compact magnet and installation **CASE 1** or **CASE 3**
 - An example of the high-speed ring magnet is shown in the outline drawing in section 5.1.1 (5).
* Manufacturing a jig is recommended for mass production.
- 4) Connector used in amplifier
 - BKO-C1810 : Oil proof-type
 - BKO-C1730 : Not oil proof-typeInstall both type at a place not subject to oil.
- 5) The cable between the amplifier and the controller should be laid down apart from high-voltage cables.
- 6) Check the connector wiring, securely engage the receptacle and tighten connector lock screws.

5. Optional Specifications and Parts

(5) Magnesensor orientation parts (Optionally supplied parts)

Select the combination of the magnesensor parts for magnesensor orientation from the table below.

| Type | Permissible speed [rpm] | Model | Combination | | |
|---------------------|-------------------------|-----------------------------|-------------|--------|--------|
| | | | Amplifier | Sensor | Magnet |
| Standard | 0 ~ 6000 | MAGSENSOR BKO-C1810H01~3 | H01 | H02 | H03 |
| High-speed standard | 0 ~ 12000 | MAGSENSOR BKO-C1730H01.2.6 | H01 | H02 | H06 |
| High-speed small | 0 ~ 12000 | MAGSENSOR BKO-C1730H01.2.9 | H01 | H02 | H09 |
| High-speed ring | 0 ~ 25000 | MAGSENSOR BKO-C1730H01.2.11 | H01 | H02 | H41 |
| High-speed ring | 0 ~ 25000 | MAGSENSOR BKO-C1730H01.2.12 | H01 | H02 | H42 |
| High-speed ring | 0 ~ 30000 | MAGSENSOR BKO-C1730H01.2.13 | H01 | H02 | H43 |
| High-speed ring | 0 ~ 30000 | MAGSENSOR BKO-C1730H01.2.14 | H01 | H02 | H44 |

Outline dimensions:

● Amplifier H01

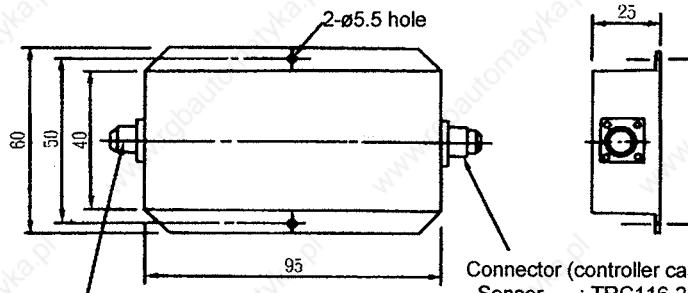

Connector (sensor side)
 For BKO-C1810H01, R04-R-8F is used.
 For BKO-C1730H01, TRC116-21A10-7F is used.

Connector (controller cable side)
 Sensor : TRC116-21A10-7M
 Cable : TRC116-12A10-7F10.5

● Sensor H02

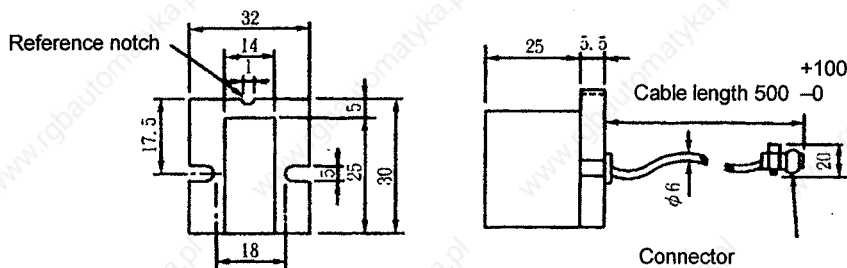

Connector
 For BKO-C1810H02, R04-R-8M is used.
 For BKO-C1730H02, TRC116-21A10-7M is used.

5. Optional Specifications and Parts

● Magnet

| Part No. | Tolerable speed [r/min] | Outline drawing | | | | | | | | | | | | | | | | | | | | | | | | | | | | | | | | | | | | | | | | | | | | | | | | | | | | | | | | | | | | | | | | | | | | | | |
|--------------|-------------------------|---|------|------------|----|--------|---|----|-------|---|------------|--|--|------------|---|---|---|---|---|---|---|---|-------|---|--------------|-----|-----------------------|----|----|----|--------|---|----|-------|---|------------|--------------|----|-----------------------|----|----|----|--------|---|----|-------|---|-----------|--------------|----|-----------------------|----|----|----|--------|---|----|-------|---|-----------|--------------|----|-----------------------|----|----|----|--------|---|----|-------|---|-----------|
| H03 | 0 ~ 6000 | <p style="text-align: right;">Weight: $40 \pm 1.5\text{g}$</p> | | | | | | | | | | | | | | | | | | | | | | | | | | | | | | | | | | | | | | | | | | | | | | | | | | | | | | | | | | | | | | | | | | | | | | |
| H06 | 0 ~ 12000 | | | | | | | | | | | | | | | | | | | | | | | | | | | | | | | | | | | | | | | | | | | | | | | | | | | | | | | | | | | | | | | | | | | | | | | |
| H09 | 0 ~ 12000 | <p style="text-align: right;">Installation screw: M4 screw Weight: $14.8 \pm 0.7\text{g}$</p> | | | | | | | | | | | | | | | | | | | | | | | | | | | | | | | | | | | | | | | | | | | | | | | | | | | | | | | | | | | | | | | | | | | | | | |
| H41 | 0 ~ 25000 | <p style="text-align: center;">* Polarity (N,S) is indicated on the side wall of cover. Sensor head should be installed so that the reference notch of sensor head comes on the case side. Refer to P.79 and after for the details.</p> | | | | | | | | | | | | | | | | | | | | | | | | | | | | | | | | | | | | | | | | | | | | | | | | | | | | | | | | | | | | | | | | | | | | | | |
| H42 | 0 ~ 25000 | | | | | | | | | | | | | | | | | | | | | | | | | | | | | | | | | | | | | | | | | | | | | | | | | | | | | | | | | | | | | | | | | | | | | | | |
| H43 | 0 ~ 30000 | <p style="text-align: center;">Magnet Unit: mm</p> <table border="1" style="width: 100%; border-collapse: collapse; text-align: center;"> <thead> <tr> <th rowspan="2">Type</th> <th colspan="10">Dimensions</th> <th rowspan="2">Weight (g)</th> </tr> <tr> <th>A</th> <th>B</th> <th>C</th> <th>D</th> <th>E</th> <th>F</th> <th>G</th> <th>H</th> <th>J x X</th> <th>L</th> </tr> </thead> <tbody> <tr> <td>BKO-C1730H11</td> <td>105</td> <td>$70\text{H}7+0.030-0$</td> <td>90</td> <td>28</td> <td>19</td> <td>M6x1.0</td> <td>5</td> <td>90</td> <td>70x79</td> <td>1</td> <td>1024 ± 4</td> </tr> <tr> <td>BKO-C1730H12</td> <td>94</td> <td>$60\text{H}7+0.030-0$</td> <td>79</td> <td>25</td> <td>17</td> <td>M5x0.8</td> <td>5</td> <td>79</td> <td>60x68</td> <td>1</td> <td>768 ± 4</td> </tr> <tr> <td>BKO-C1730H13</td> <td>78</td> <td>$50\text{H}7+0.025-0$</td> <td>66</td> <td>23</td> <td>15</td> <td>M5x0.8</td> <td>5</td> <td>66</td> <td>50x57</td> <td>1</td> <td>478 ± 4</td> </tr> <tr> <td>BKO-C1730H14</td> <td>66</td> <td>$40\text{H}7+0.025-0$</td> <td>54</td> <td>20</td> <td>13</td> <td>M4x0.7</td> <td>5</td> <td>54</td> <td>40x45</td> <td>1</td> <td>322 ± 4</td> </tr> </tbody> </table> | Type | Dimensions | | | | | | | | | | Weight (g) | A | B | C | D | E | F | G | H | J x X | L | BKO-C1730H11 | 105 | $70\text{H}7+0.030-0$ | 90 | 28 | 19 | M6x1.0 | 5 | 90 | 70x79 | 1 | 1024 ± 4 | BKO-C1730H12 | 94 | $60\text{H}7+0.030-0$ | 79 | 25 | 17 | M5x0.8 | 5 | 79 | 60x68 | 1 | 768 ± 4 | BKO-C1730H13 | 78 | $50\text{H}7+0.025-0$ | 66 | 23 | 15 | M5x0.8 | 5 | 66 | 50x57 | 1 | 478 ± 4 | BKO-C1730H14 | 66 | $40\text{H}7+0.025-0$ | 54 | 20 | 13 | M4x0.7 | 5 | 54 | 40x45 | 1 | 322 ± 4 |
| Type | Dimensions | | | | | | | | | | Weight (g) | | | | | | | | | | | | | | | | | | | | | | | | | | | | | | | | | | | | | | | | | | | | | | | | | | | | | | | | | | | | | |
| | A | B | C | D | E | F | G | H | J x X | L | | | | | | | | | | | | | | | | | | | | | | | | | | | | | | | | | | | | | | | | | | | | | | | | | | | | | | | | | | | | | | |
| BKO-C1730H11 | 105 | $70\text{H}7+0.030-0$ | 90 | 28 | 19 | M6x1.0 | 5 | 90 | 70x79 | 1 | 1024 ± 4 | | | | | | | | | | | | | | | | | | | | | | | | | | | | | | | | | | | | | | | | | | | | | | | | | | | | | | | | | | | | | |
| BKO-C1730H12 | 94 | $60\text{H}7+0.030-0$ | 79 | 25 | 17 | M5x0.8 | 5 | 79 | 60x68 | 1 | 768 ± 4 | | | | | | | | | | | | | | | | | | | | | | | | | | | | | | | | | | | | | | | | | | | | | | | | | | | | | | | | | | | | | |
| BKO-C1730H13 | 78 | $50\text{H}7+0.025-0$ | 66 | 23 | 15 | M5x0.8 | 5 | 66 | 50x57 | 1 | 478 ± 4 | | | | | | | | | | | | | | | | | | | | | | | | | | | | | | | | | | | | | | | | | | | | | | | | | | | | | | | | | | | | | |
| BKO-C1730H14 | 66 | $40\text{H}7+0.025-0$ | 54 | 20 | 13 | M4x0.7 | 5 | 54 | 40x45 | 1 | 322 ± 4 | | | | | | | | | | | | | | | | | | | | | | | | | | | | | | | | | | | | | | | | | | | | | | | | | | | | | | | | | | | | | |
| H44 | 0 ~ 30000 | <p style="text-align: center;">Installation of magnet</p> <p>Caution on installation of H41~44</p> <ol style="list-style-type: none"> 1. Tolerance to shaft dimension should be "h6". 2. 2-øG holes can be used for positioning of spindle and magnet. 3. Magnet shall be installed as shown to the left. 4. Misalignment between sensor head and magnet center line shall be within $\pm 2\text{mm}$. 5. Reference notch of sensor head shall come on the case side. | | | | | | | | | | | | | | | | | | | | | | | | | | | | | | | | | | | | | | | | | | | | | | | | | | | | | | | | | | | | | | | | | | | | | | |

5. Optional Specifications and Parts

5.1.2 4096-point orientation using encoder

(1) Connection

Refer to "1.4 Configuration" for the connection of the encoder and spindle drive unit.

(2) Installation conditions

Mechanical characteristics for rotation

- a. Inertia : $0.1 \times 10^{-4} \text{kg} \cdot \text{m}^2$ or less
- b. Shaft friction torque : 0.98N·m or less
- c. Shaft angle acceleration : 10^4rad/sec^2 or less
- d. Tolerable speed : 7,030r/min (rpm)

Mechanical configuration

- a. Bearings : Non-lubricated for 100,000 or more rotations (at 2,000r/min)
Non-lubricated for 20,000 hours or more at 6,000r/min
- b. Shaft amplitude : 0.02mm or less at 15mm from end
- c. Tolerable load : Thrust direction 10kg (5kg during operation)
Radial direction 20kg (10kg during operation)
- d. Weight : 1.5kg max
- e. Squareness of flange to shaft : 0.05mm or less
- f. Flange matching eccentricity : 0.05mm or less

Working conditions

- a. Working temperature range : -5°C to $+55^\circ\text{C}$
- b. Storage temperature range : -20°C to $+85^\circ\text{C}$
- c. Humidity range : 95% PH (at 40°C) for 8 hours
- d. Vibration resistance : 5 to 50Hz, total vibration width 1.5mm, each shaft for 30 min.
- e. Impact resistance : 294.20m/s^2 (30G) 11msec, each shaft 6 times

5. Optional Specifications and Parts

(3) Handling

- a. Use of a flexible coupling is recommended for the coupling of the encoder and spindle shaft in terms of improving the encoder life and performance.
- b. Installation precision
The precision shown below should be secured for the encoder installation section engaging section and installation surface sway in order to maximize the coupling life.

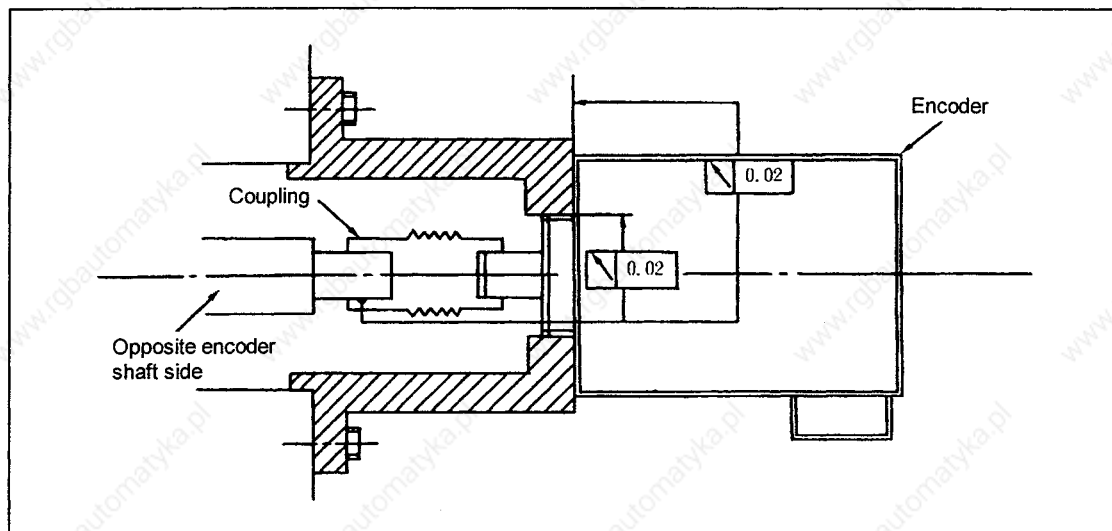

- c. Recommended coupling

| | | Recommendation 1 | Recommendation 2 |
|--------------------------|--------------------|-------------------------------------|-------------------------------------|
| Manufacturer | | Tokushu Seiko | Eagle |
| Model | | Model M1 | FCS38A |
| Resonance frequency | | 1,374Hz | 3,515Hz |
| Position detection error | | $0.8 \times 10^{-3} \text{ }^\circ$ | $1.2 \times 10^{-3} \text{ }^\circ$ |
| Tolerable speed | | 20,000r/min (rpm) | 10,000 r/min (rpm) |
| Mis-alignment | Core deviation | 0.7mm | 0.16mm |
| | Angle displacement | 1.5° | 1.5° |
| Outline dimensions | Max. length | 74.5mm | 33mm |
| | Max. diameter | ø57mm | ø38mm |

Refer to the coupling catalogue for details on the coupling.

5.1.3 4096-point orientation using motor built-in encoder

The motor built-in encoder built-in motor with Z-phase signal is required for this specification. This can be used only when the motor and spindle coupling is the direction coupling or when the timing belt with a reduction ratio of 1 is used.

(1) Connection

Refer to "1.4 configuration" for the connection of the signal wires.

(2) Installation

The encoder is built into the motor so no special detector needs to be installed.

5.1.4 Operation of orientation

(1) Operation modes

There are three modes of orientation stop. Desired mode can be selected by setting parameter SPECO.

1. PRE :

..... (a) Spindle approaches the stop position in the direction of on-going rotation.

2. Forward orientation :

..... (b) Spindle approaches the stop position in forward direction of rotation, regardless of direction of on-going rotation.

3. Reverse orientation :

..... (c) Spindle approaches the stop position in the reverse direction of rotation, regardless of direction of on-going rotation.

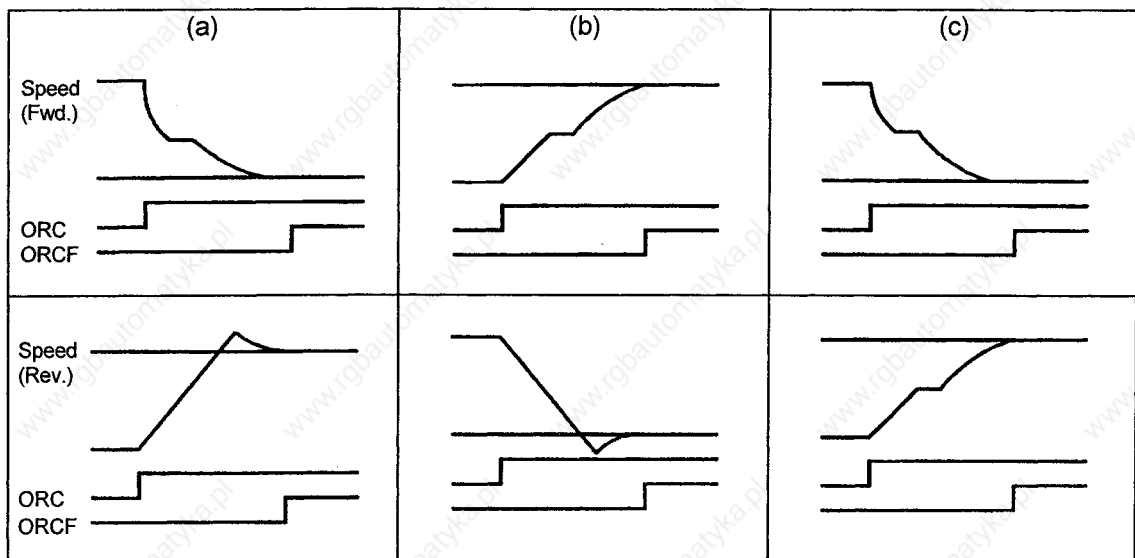

(2) Operation sequence

- 1) When orientation command ORC is given, motor speed changes from the steady run speed to "Position loop changeover speed" and at the same time the multi-point orientation stop position is read.
- 2) When motor speed reaches the "Position loop changeover speed", control mode changes from speed control to positioning control (position loop gain parameter (Note 1)). ("Position loop changeover speed" is automatically set when position loop gain is specified by parameter.)

5. Optional Specifications and Parts

- 3) When control mode changes, distance to the orientation stop position is calculated and the motor is decelerated in the set pattern (specified by parameter CSP) to enter the orientation mode.
- 4) When the spindle enters the in-position range (set by parameter OINP), "oriented spindle stop complete signal (in-position)" ORCF turns on.
- 5) The stop position zero point can be shifted by setting parameter OPST.
- 6) When orientation command (ORC) is removed, the motor is accelerated to the previously specified steady run speed.

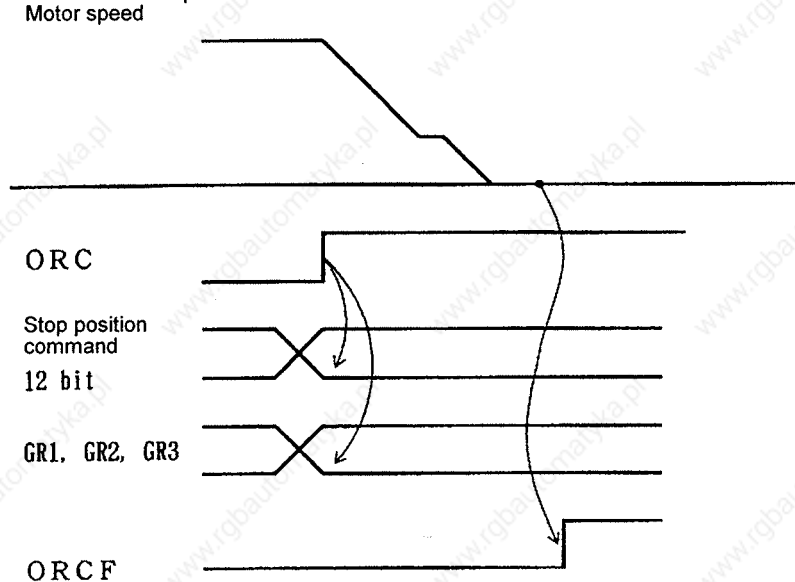

(Note) PGM is used for the magnesensor and motor built-in encoder orientation and PGE is used for the encoder orientation.

The stopping position according to the encoder installation direction is as shown below:

| | Case 1 | Case 2 |
|------------------------|---|---|
| Installation direction | | |
| Normal orientation | <p style="text-align: center;">Looking from arrow A</p> | <p style="text-align: center;">Looking from arrow A</p> |

5. Optional Specifications and Parts

(3) Diagram of relation of parameters for orientation

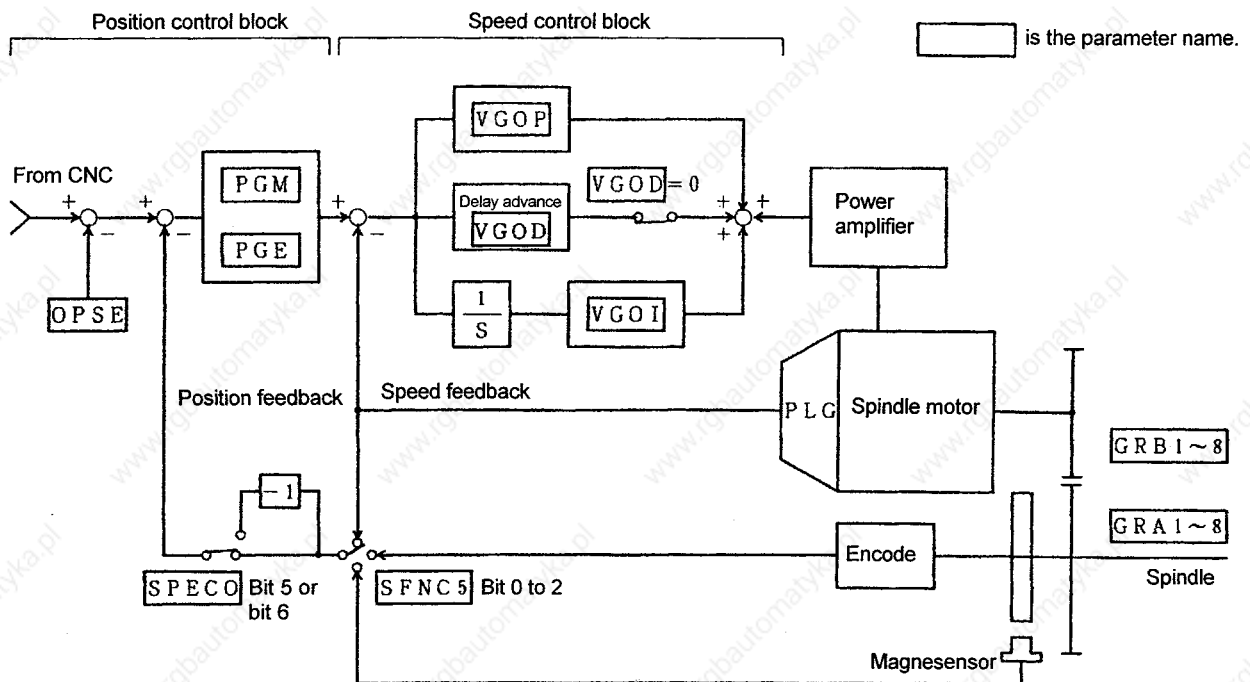

5.2 Synchronous tap function (option)

There are two types of synchronous tap

1. Closed type synchronous tap
2. Semi-closed type synchronous tap

5.2.1 Closed type synchronous tap

A position loop can be built up with position signal from an encoder installed on spindle.

(1) Connection

Refer to "1.4 Configuration" for the connection of the encoder and spindle drive unit.

(2) Installation of encoder

For installation of encoder, refer to the pages related to encoder orientation.

5.2.2 Semi-closed type synchronous tap

A position loop can be built up with position signal from motor built-in encoder.

A special detector is not required for synchronous tap if the spindle is coupled to the motor shaft directly or through gears.

(When belt or timing belt is used, closed type synchronous tap is applicable.)

It is also applicable to standard motor having no Z-phase control.

(1) Connection

No additional connection is required for semi-closed type synchronous tap.

5.2.3 Operation of synchronous tap

One of synchronous tap operation modes can be selected by parameter.

- 1) Synchronous tap starts after zero point return (parameter SPECT-bitE is set to "0").
- 2) Synchronous tap starts after deceleration and stop (parameter SPECT-bitE is set to "1").

The operation of synchronous tap is conditioned as shown below.

○ : Available × : Not available

| | Without orientation | Magnesensor orientation | Encoder orientation | Motor built-in encoder orientation |
|---|---------------------|-------------------------|---------------------|------------------------------------|
| Synchronous tap after zero point return | × | ○ | ○ | ○ |
| Synchronous tap after deceleration and stop | ○ | ○ | ○ | ○ |

5. Optional Specifications and Parts

5.3 C-axis control (optional)

5.3.1 When using encoder (OSE90K + 1024 BKO-NC6336H01)

(1) Connection

Refer to page "1.4 Configuration" for the connection of the encoder and spindle drive unit.

(2) Installation conditions

Mechanical characteristics for rotation

- a. Inertia : $0.1 \times 10^{-4} \text{kg} \cdot \text{m}^2$ or less
- b. Shaft friction torque : 0.98N·m or less
- c. Shaft angle acceleration : 10^5rad/sec^2 or less
- d. Tolerable speed : 7,030r/min (rpm)

Mechanical configuration

- a. Bearings : Non-lubricated for 100,000 or more rotations (at 2,000r/min)
Non-lubricated for 20,000 hours or more at 6,000r/min
- b. Shaft amplitude : 0.02mm or less at 15mm from end
- c. Tolerable load : Thrust direction 10kg (5kg during operation)
Radial direction 20kg (10kg during operation)
- d. Weight : 2kg max
- e. Squareness of flange to shaft : 0.05mm or less
- f. Flange matching eccentricity : 0.05mm or less

Working conditions

- a. Working temperature range : -5°C to $+55^\circ\text{C}$
- b. Storage temperature range : -20°C to $+85^\circ\text{C}$
- c. Humidity range : 95% PH (at 45°C) for 8 hours
- d. Vibration resistance : 5 to 50Hz, total vibration width 1.5mm, each shaft for 30 min.
- e. Impact resistance : $294, 20\text{m/s}^2$ (30G) 11msec, each shaft 10 times

5. Optional Specifications and Parts

(3) Handling

a. Installation of encoder

Use of a flexible coupling is recommended for the coupling of the encoder and spindle shaft in terms of improving the encoder life and performance.

b. Installation precision

The precision shown below should be secured for the encoder installation section engaging section and installation surface sway to secure the coupling life.

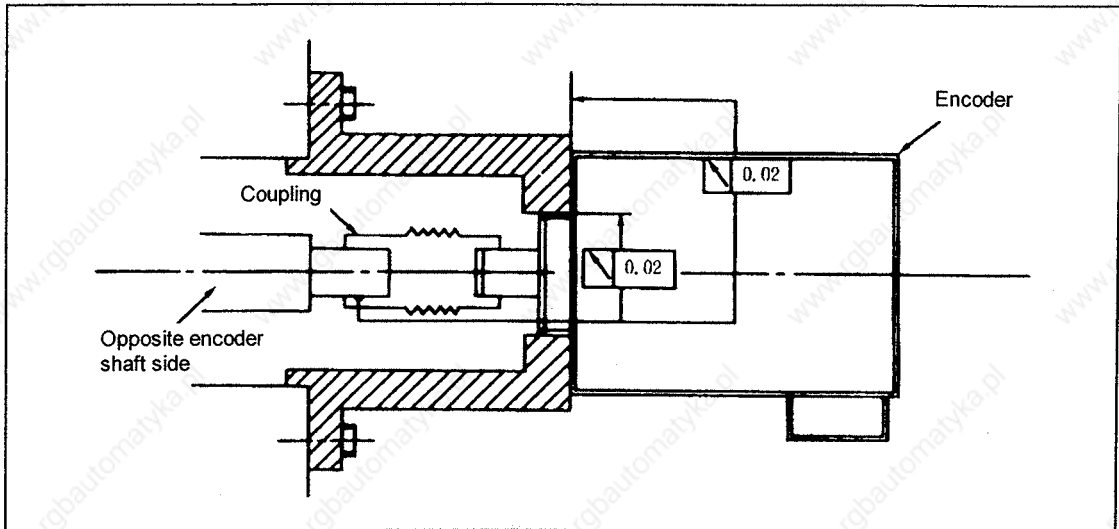

c. Recommended coupling

| | | Recommendation 1 | Recommendation 2 |
|--------------------------|--------------------|--------------------------------------|--------------------------------------|
| Manufacturer | | Tokushu Seiko | Eagle |
| Model | | Model M1 | FCS38A |
| Resonance frequency | | 1,374 Hz | 3,515 Hz |
| Position detection error | | $0.8 \times 10^{-3} \text{ } ^\circ$ | $1.2 \times 10^{-3} \text{ } ^\circ$ |
| Tolerable speed | | 20,000 r/min (rpm) | 10,000 r/min (rpm) |
| Mis-alignment | Core deviation | 0.7 mm | 0.16 mm |
| | Angle displacement | 1.5° | 1.5° |
| Dimensions | Max. length | 74.5 mm | 33 mm |
| | Max. diameter | ø57 mm | ø38 mm |

Refer to the coupling catalogue for details on the coupling.

d. Cable

1) Consider the following points to allow the encoder to be used to its fullest.

A **4.5V** or higher power supply must be secured for the encoder.

For example:

- ① Increase the +5V, 0V wire size.
- ② Use two or more wires for +5V, 0V.
- ③ Keep the cable length as short as possible.

2) Others

The encoder is a precision device so do not apply strong impact, etc., to it. Incorrect wiring will cause trouble. Always confirm the connector name and pin No., etc., before wiring.

5. Optional Specifications and Parts

(4) C-axis control parts (Optionally supplied parts)

- Encoder OSE90K + 1024 BKO-NC6336H01

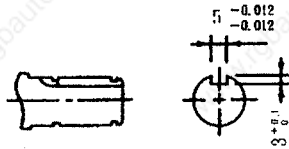
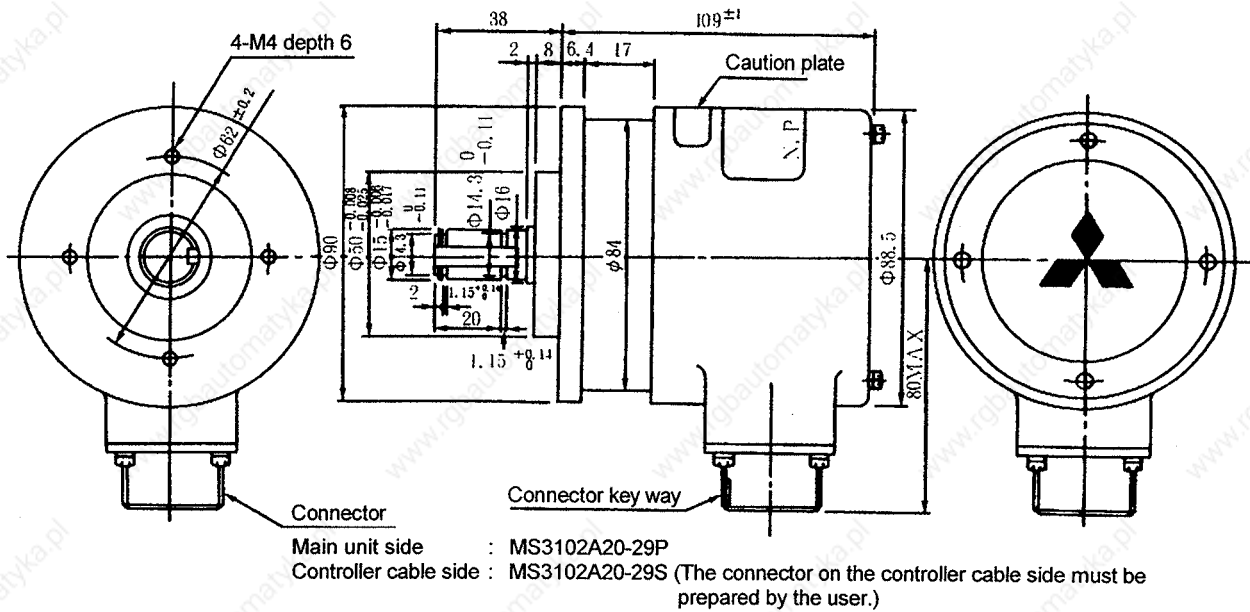

- Note 1.** The max. encoder speed must be 6,000r/min or less.
Note 2. The dimensional tolerance that is not specified is $\pm 0.5\text{mm}$.

Signal

| | Generated signals | Remarks |
|-----|-------------------|---|
| 1ch | 1024 C/T | A • B-phase, \bar{A} • \bar{B} -phase |
| 2ch | 1 C/T | Z-phase • \bar{Z} -phase |
| 3ch | 90000 C/T | C • D-phase, \bar{C} • \bar{D} -phase |
| 4ch | 1 C/T | Y-phase • \bar{Y} • B-phase |

Connector pin layout

| Pin | Function |
|-----|-------------------------------|
| A | 1ch A-phase |
| B | 2ch Z-phase |
| C | 1ch B-phase |
| D | — |
| E | Case grounding |
| F | 3ch C-phase |
| G | 3ch D-phase |
| H | DC +5V _{+5%} -10% |
| J | OV |

| Pin | Function |
|-----|----------------------|
| K | OV |
| L | 3ch \bar{C} -phase |
| M | 3ch \bar{D} -phase |
| N | 1ch \bar{A} -phase |
| P | 2ch \bar{Z} -phase |
| R | 1ch \bar{B} -phase |
| S | 4ch Y-phase |
| T | 4ch \bar{B} -phase |

- Grounding plate and cable clamp fittings
Refer to section 5.4 "Single parts".

5. Optional Specifications and Parts

5.3.2 When using built-in encoder (MBE90K)

Refer to the MBE90K (built-in C-axis encoder) Specifications and Instruction Manual [BNP-A2993-41].

5.3.3 When using built-in encoder (MHE90K)

Refer to the MHE90K (built-in C-axis encoder) Specifications and Instruction Manual [BNP-A2993-44].

5. Optional Specifications and Parts

5.4 Single parts (optionally supplied parts)

5.4.1 Power step-down transformer

When available power supply is at 400V, use this optional step-down transformer.

(1) 12-23kVA (ITEM1 ~ 3)

| Item | Capacity (kVA) | Dimensions | | Weight (kg) | Remarks |
|------|----------------|------------|--|-------------|---------|
| | | A | | | |
| 1 | 12 | 230 | | 90 | 7.5K |
| 2 | 17 | 175 | | 115 | 11K |
| 3 | 23 | 215 | | 130 | 15K |

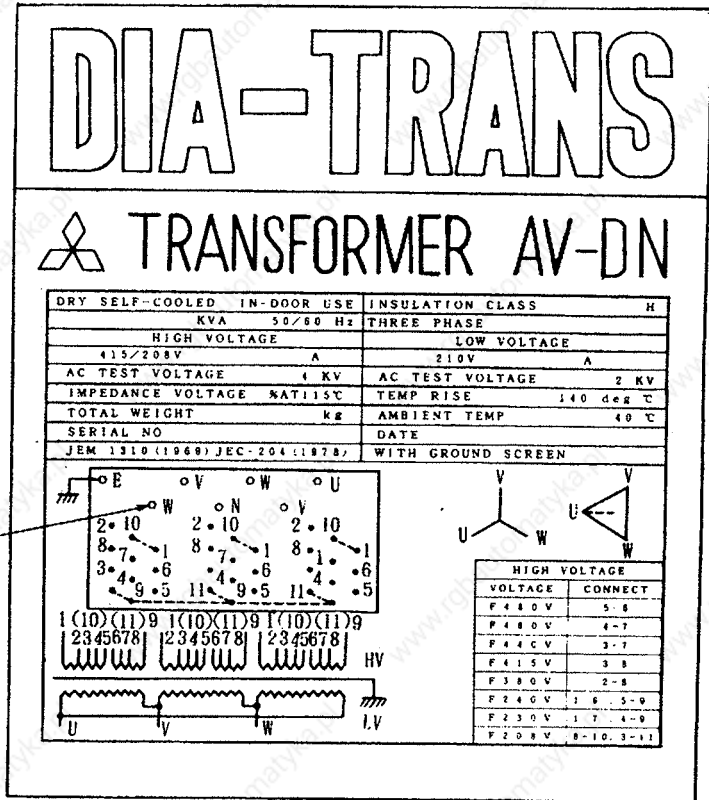

Nameplate

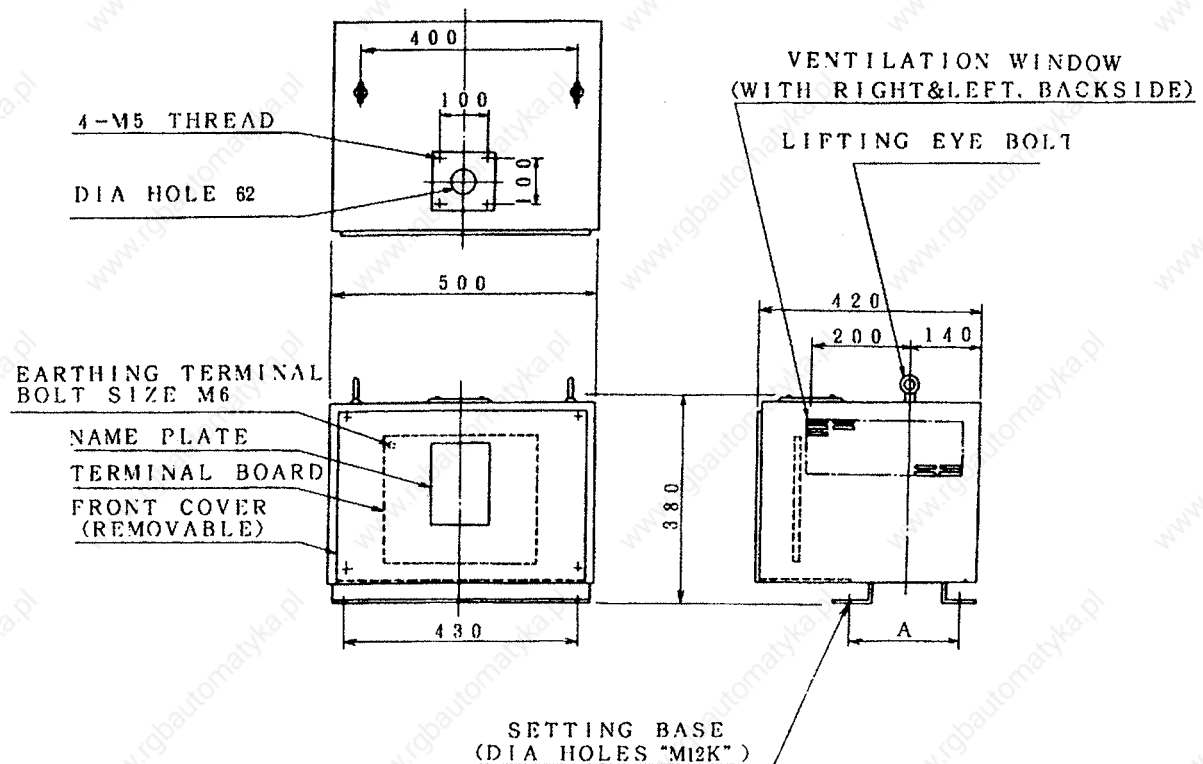

5. Optional Specifications and Parts

(2) 30kVA ~ 75kVA (ITEM4 ~ 8)

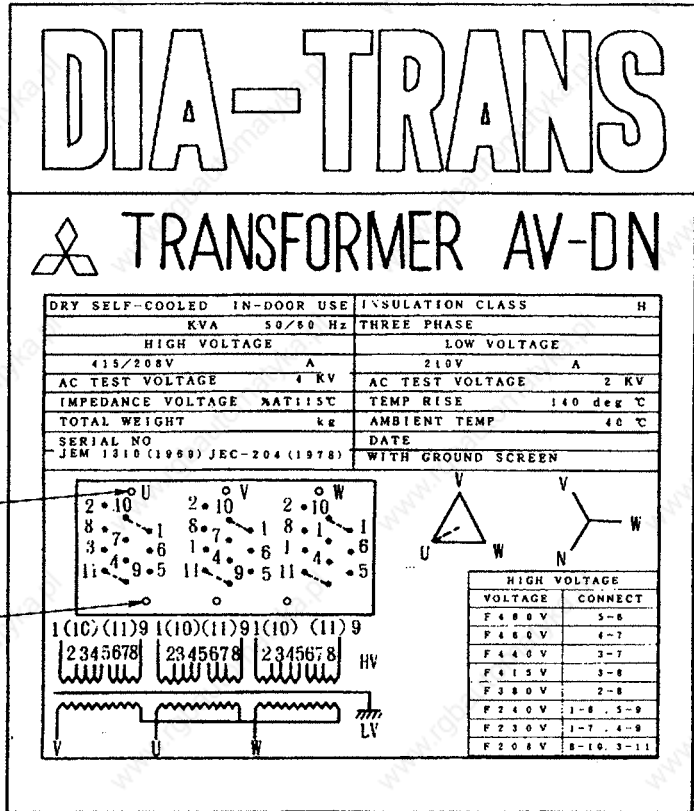

| Item | Capacity (kVA) | Dimensions | | | | | | | Weight (kg) | Remarks |
|------|----------------|------------|-----|-----|-----|-----|-----|-----|-------------|----------|
| | | A | B | C | D | E | F | G | | |
| 4 | 30 | 535 | 395 | 625 | 460 | 250 | 445 | M12 | 165 | 18.5K |
| 5 | 37 | 535 | 395 | 665 | 460 | 250 | 485 | M12 | 185 | 22K, 26K |
| 6 | 44 | 535 | 425 | 665 | 460 | 265 | 485 | M12 | 205 | 30K |
| 7 | 60 | 625 | 425 | 815 | 540 | 255 | 625 | M16 | 280 | 37K |
| 8 | 75 | 625 | 425 | 840 | 540 | 270 | 650 | M16 | 320 | 45K |

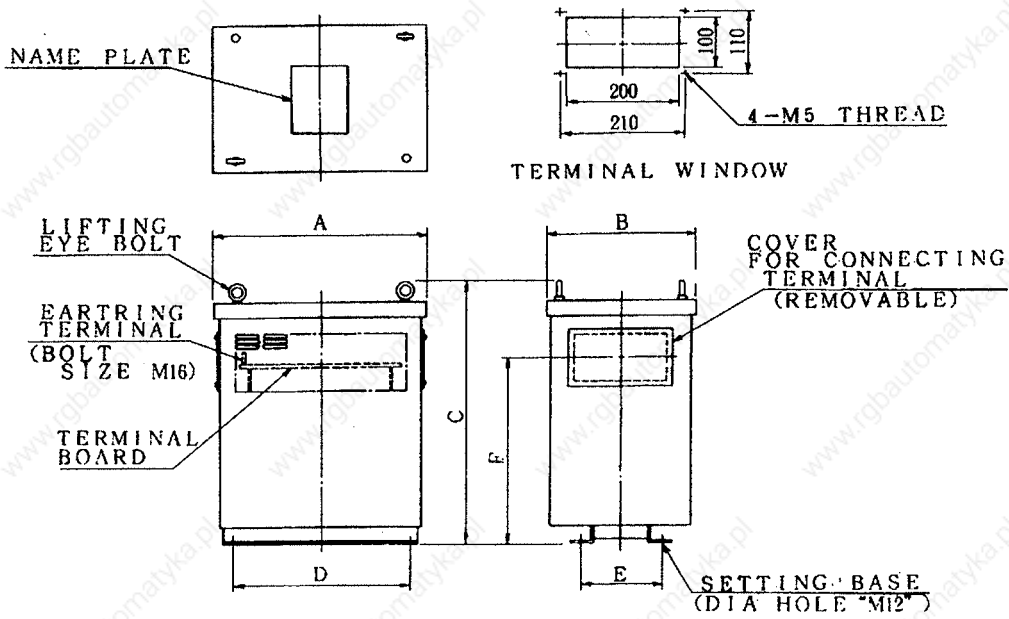

5. Optional Specifications and Parts

5.4.2 Noise filter

(1) Selection

If radio noise must be reduced, select a noise filter from the following table according to the power supply unit model:

| MDS-A-CV- MDS-B-CV- | Noise filter name (Tohoku Kinzoku) |
|------------------------|------------------------------------|
| 37 | LF-330 |
| 55 | LF-340 |
| 75 | LF-350 |
| 110 | LF-360 |
| 150, 185 | LF-380K |
| 220, 260, 300 | Two LF-380K units in parallel |

(2) Noise filter installation position

Insert the noise filter in the unit input.

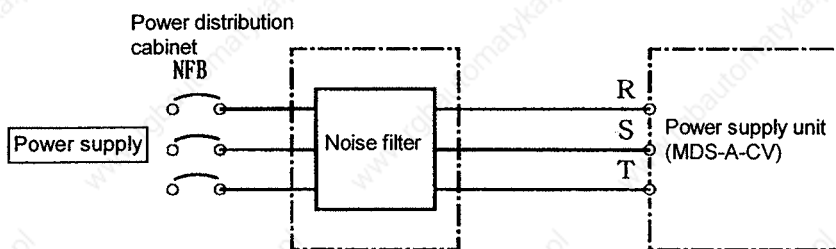

* Connect to the transformer input in power supply units that use the transformer.

(3) Specifications

| Name | Rated voltage AC/DC (V) | Rated current AC/DC (A) | Tested voltage AC 1 min. (V) Between case terminals | Insulation resistance (MΩ) 500VDC | Leakage current (mA) 250V 60Hz | Working temperature range (°C) |
|------|----------------------------|----------------------------|--|--|--------------------------------------|--------------------------------------|
| 330 | 200V | 30A | 1500 | > 300 | < 1 | -20 ~ +55 |
| 340 | 200V | 40A | 1500 | > 300 | < 1 | -20 ~ +45 |
| 350 | 200V | 50A | 1500 | > 300 | < 1 | -20 ~ +45 |
| 360 | 200V | 60A | 1500 | > 300 | < 1 | -20 ~ +45 |
| 380K | 200V | 80A | 2000 | > 300 | < 5 | -25 ~ +55 |

5. Optional Specifications and Parts

(4) Shape and dimensions

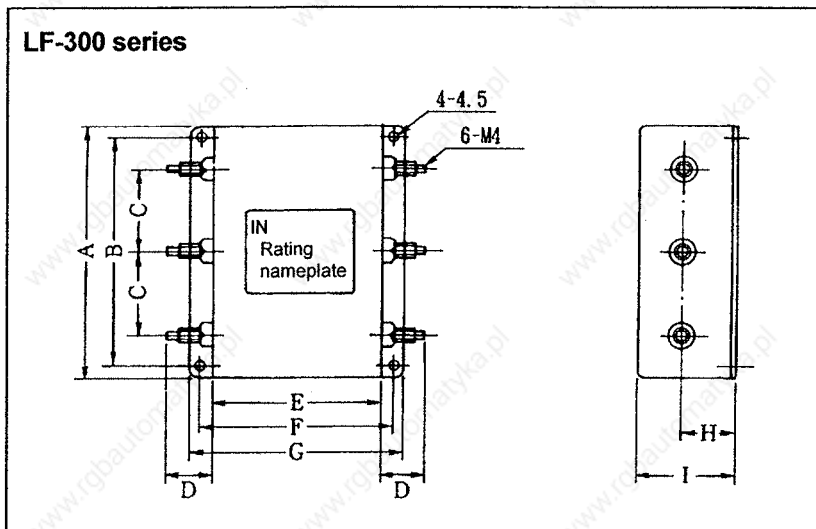

Unit: mm

| Part name | A | B | C | D | E | F | G | H | I |
|-----------|-----|-----|----|----|-----|-----|-----|----|-----|
| LF-330 | 180 | 170 | 60 | 29 | 120 | 135 | 150 | 35 | 65 |
| LF-340 | 180 | 160 | 50 | 30 | 200 | 220 | 240 | 40 | 80 |
| LF-350 | 180 | 160 | 50 | 30 | 200 | 220 | 240 | 40 | 80 |
| LF-360 | 200 | 180 | 60 | 30 | 300 | 320 | 340 | 50 | 100 |

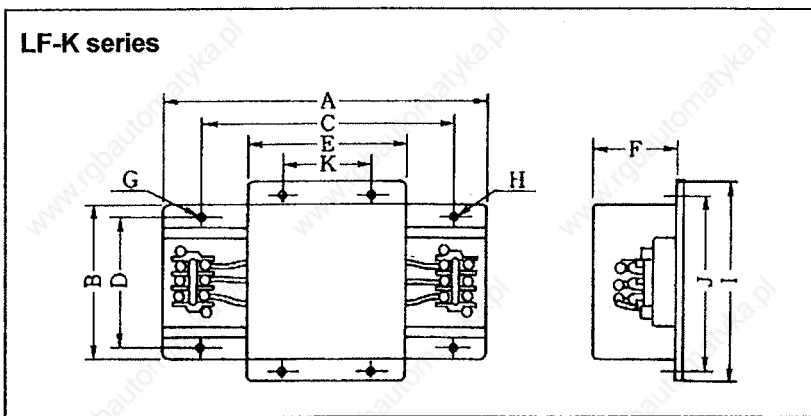

Unit: mm

| Name | Terminal plate | A | B | C | D | E | F | G | H |
|---------|----------------|-----|-----|-----|-----|-----|-----|--------------|------------|
| LF-380K | TE-K22 M6 | 670 | 400 | 560 | 380 | 500 | 170 | 9x6.5 ϕ | 6.5 ϕ |

5. Optional Specifications and Parts

5.5 Other optional specifications

Refer to the following optional specifications for each model shown below for optional specifications not explained in this manual.

| | Title of optional specifications | Specifications No. |
|---|--|---------------------------|
| ① | MDS-A Series coil changeover function optional specifications | BNP-A2993-23 |
| ② | MBE90K (built-in C-axis encoder) specifications and instruction manual | BNP-A2993-41 |
| ③ | MBE90K (built-in C-axis encoder) specifications and instruction manual | BNP-A2993-44 |

5.6 Theoretical acceleration and deceleration times

In the calculation described below, load torque is assumed to be zero. Therefore, acceleration and deceleration times determined here somewhat differ from actual acceleration and deceleration times.

(1) Definition

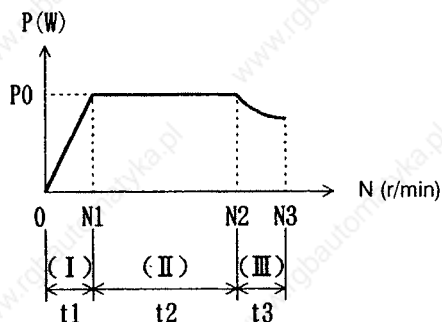

- (Note)** 1) "Po" is (Rated power × 1.2).
 Example : For spindle of 2.2/3.7kW,
 $P_o = 3700 \times 1.2 = 4440 \text{ (W)}$
 2) $GD^2 = (\text{Motor } GD^2) + (\text{Motor shaft conversion load } GD^2) \text{ (kg}\cdot\text{m}^2)$

(2) Acceleration/deceleration time "t"

- 1) Constant torque zone

$$t_1 = \frac{1.03 \times GD^2 \times N_1^2}{375 \times P_o} \text{ (sec)}$$
- 2) Constant output (power) zone

$$t_2 = \frac{1.03 \times GD^2 \times (N_2^2 - N_1^2)}{2 \times 375 \times P_o} \text{ (sec)}$$
- 3) Reduced output zone

$$t_3 = \frac{1.03 \times GD^2 \times (N_3^3 - N_2^3)}{3 \times 375 \times P_o \times N_2}$$

Therefore, accel./decel. time t (0 → N₃) is,
 $t = t_1 + t_2 + t_3 \text{ (sec)}$

Example: { $GD_L^2 = 0.123 \text{ kg}\cdot\text{m}^2$
 For motor SJ-N3.7A
 From specification 2, $GD_M^2 = 0.021 \text{ kg}\cdot\text{m}^2$
 thus, $GD^2 = 0.021 + 0.123 = 0.144 \text{ kg}\cdot\text{m}^2$
 $t_1 = \frac{1.03 \times 0.144 \times 1500^2}{375 \times 3700 \times 1.2} = 0.200 \text{ (sec)}$
 $t_2 = \frac{1.03 \times 0.144 \times (6000^2 - 1500^2)}{2 \times 375 \times 3700 \times 1.2} = 1.503 \text{ (sec)}$
 $t_3 = \frac{1.03 \times 0.144 \times (8000^3 - 6000^3)}{3 \times 375 \times 3700 \times 1.2 \times 6000} = 1.465$
 Accel./decl. Time for 0 → 8000r/min
 $t = 0.200 + 1.503 + 1.465 = 3.168 \text{ (sec)}$

Unit conversion :

- Speed : $1 \text{ r/min} = \frac{2\pi}{60} \text{ rad/s}$
 Output (power) : $1 \text{ kW} = 1/1.3596 \text{ HP}$

Formula :

$$P = \omega T_o = (2\pi \frac{N}{60}) \times T$$

- P : Output [W]
- ω : Angular velocity [rad/s]
- T_o : Torque [N·m]
- N : Speed [r/min]
- T : Torque [N·m]

6. Large Capacity Spindle Drive

6. Large Capacity Spindle Drive

6.1 Outline dimensions

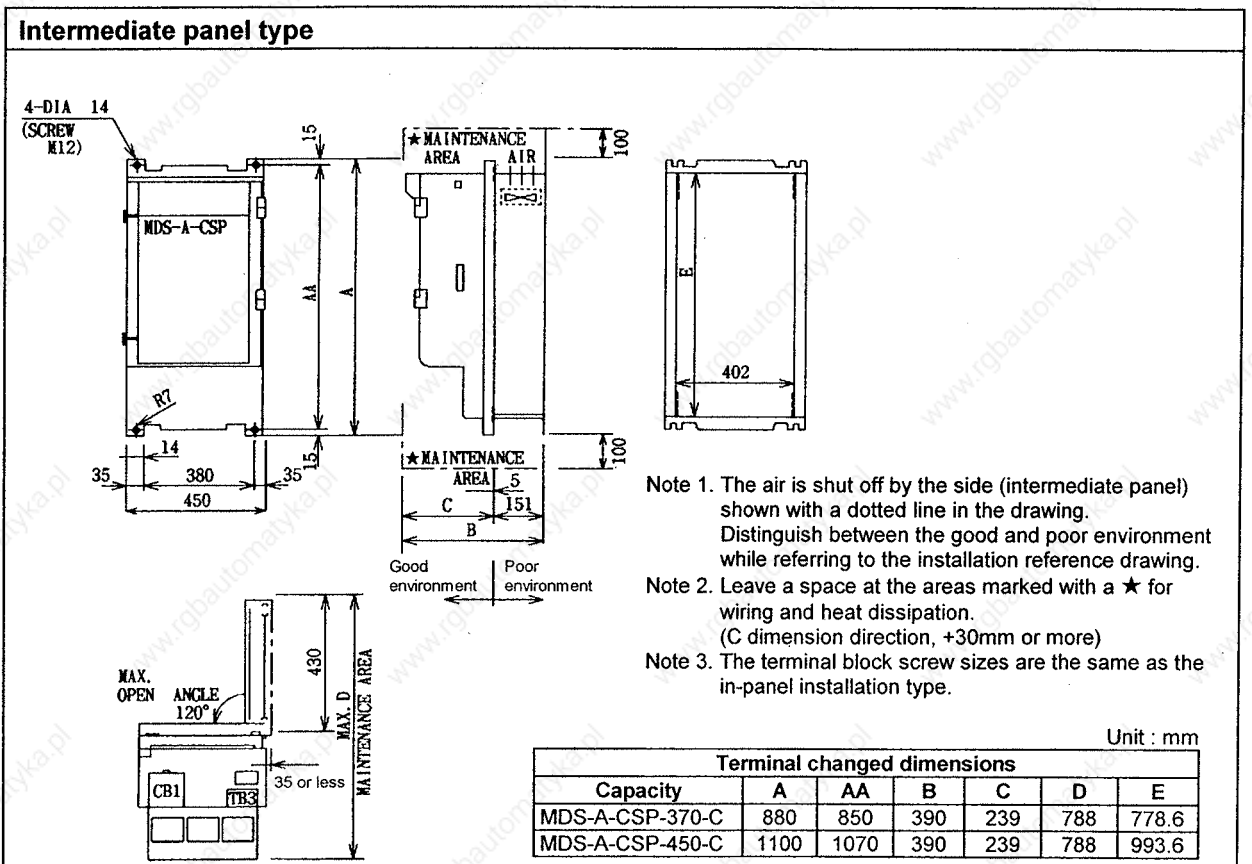
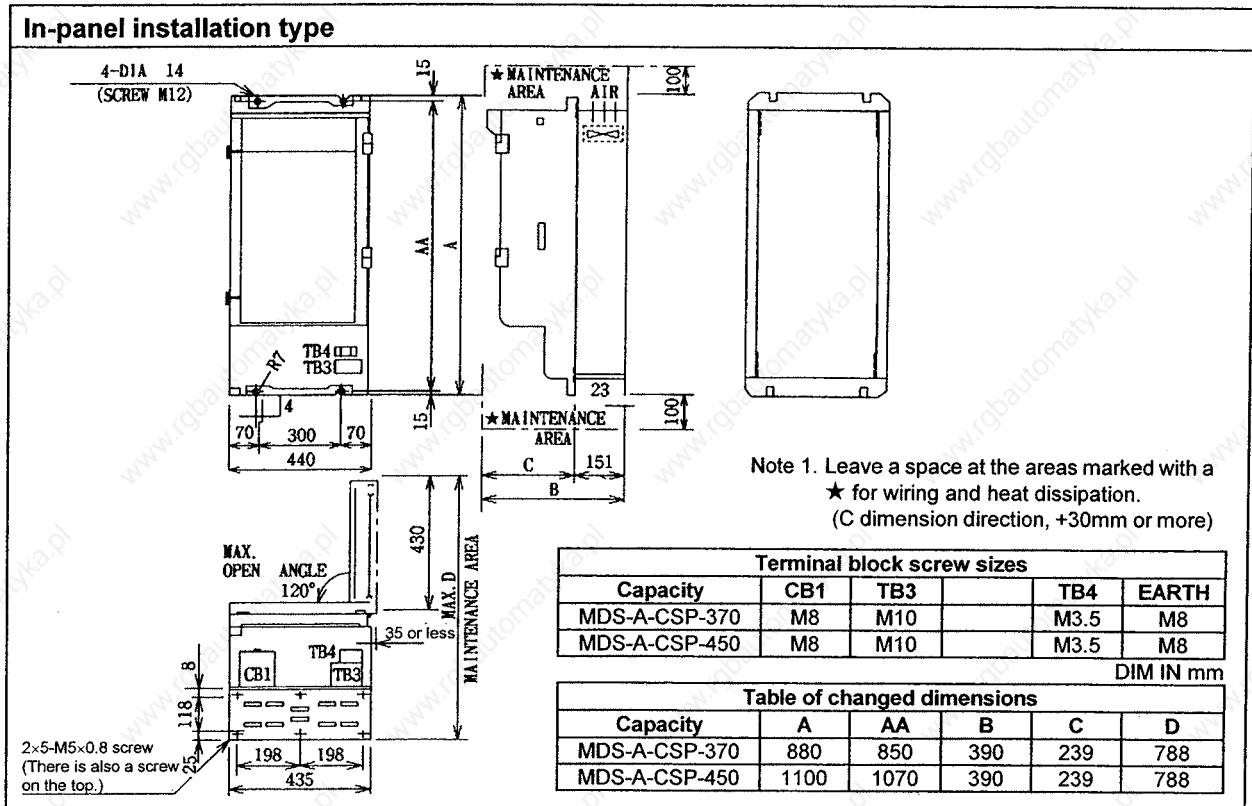

6. Large Capacity Spindle Drive

Precautions for installing intermediate panel type controller

(1) Installation procedures

1. Machine installation holes into the power distribution cabinet side as shown below.
2. Install with bolts at the four positions (B) with packing between the intermediate panel section and power distribution cabinet.

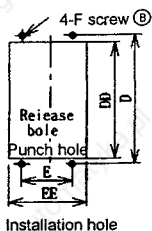

Unit : mm

| Table of changed dimensions | | | | | |
|-----------------------------|------|------|-----|-----|-----|
| Capacity | D | DD | E | EE | F |
| MDS-A-CSP-370-C | 850 | 800 | 380 | 424 | M12 |
| MDS-A-CSP-450-C | 1070 | 1020 | 380 | 424 | M12 |

(2) Installation example

Example 1.

Secure an air ventilation area when the machine surface is behind the power distribution cabinet.

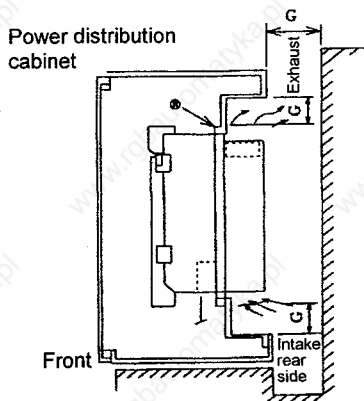

Example 2.

If the outside air cooling section is to be set outside the power distribution cabinet, make sure that cutting chips, etc., do not enter the exhaust section.

Note. Place a filter at the partition suction section shown with a dotted line when installing the unit in a poor environment (factory with large quantities of oil mist), so as to improve the cooling section air.

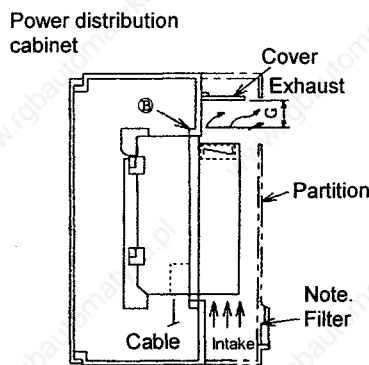

Unit : mm

| Table of changed dimensions | | |
|-----------------------------|-----|---------------------|
| Capacity | G | Intake/Exhaust area |
| MDS-A-CSP-370-C | 150 | 150 × 420 |
| MDS-A-CSP-450-C | 150 | 150 × 420 |

6. Large Capacity Spindle Drive

6.2 Connection of each unit

CAUTION

Do not apply a voltage other than that specified on each terminal. Failure to observe this could lead to breakage or trouble.

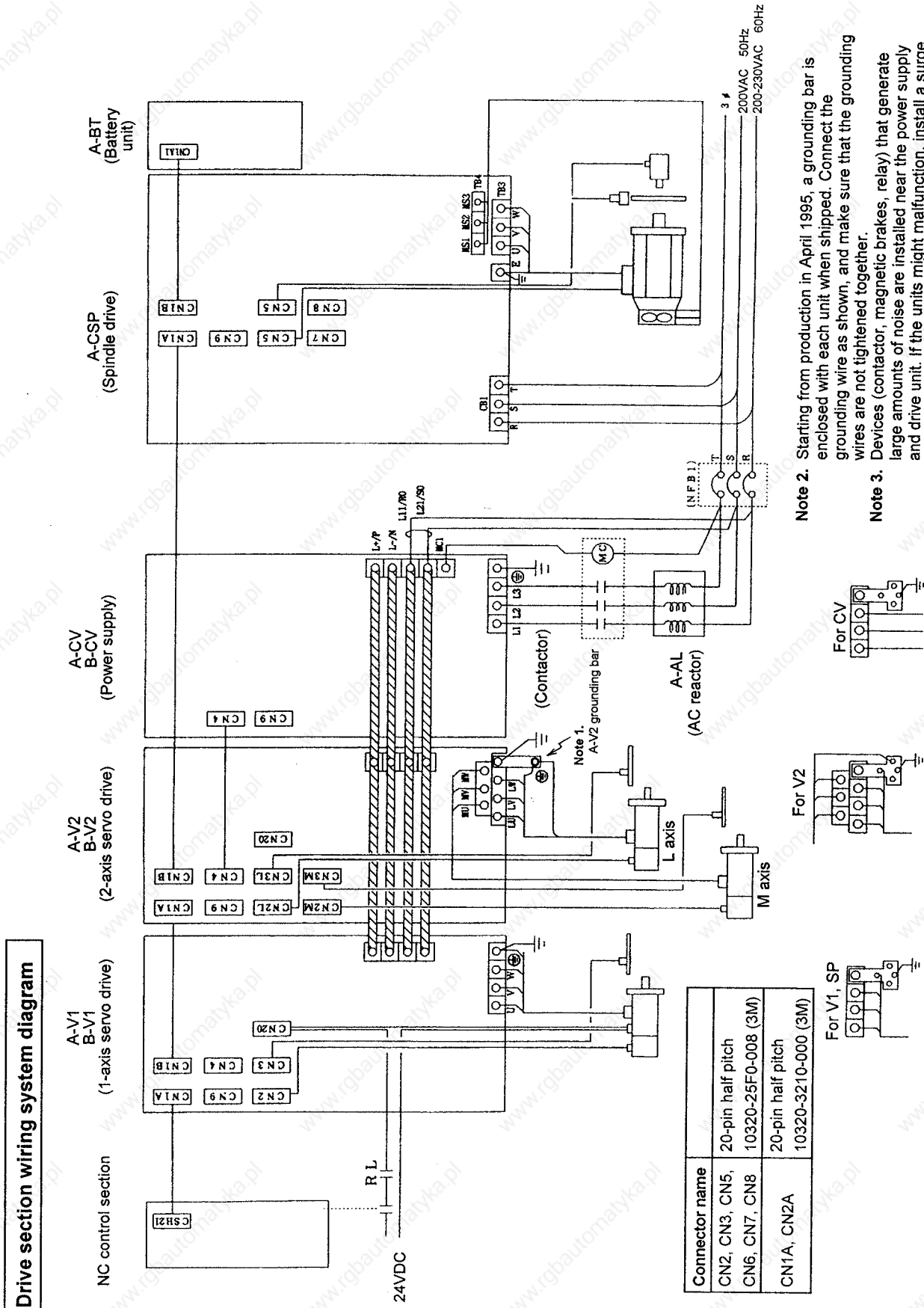

6. Large Capacity Spindle Drive

6.3 Drive section connector and cable specifications

Half-pitch cable connection system

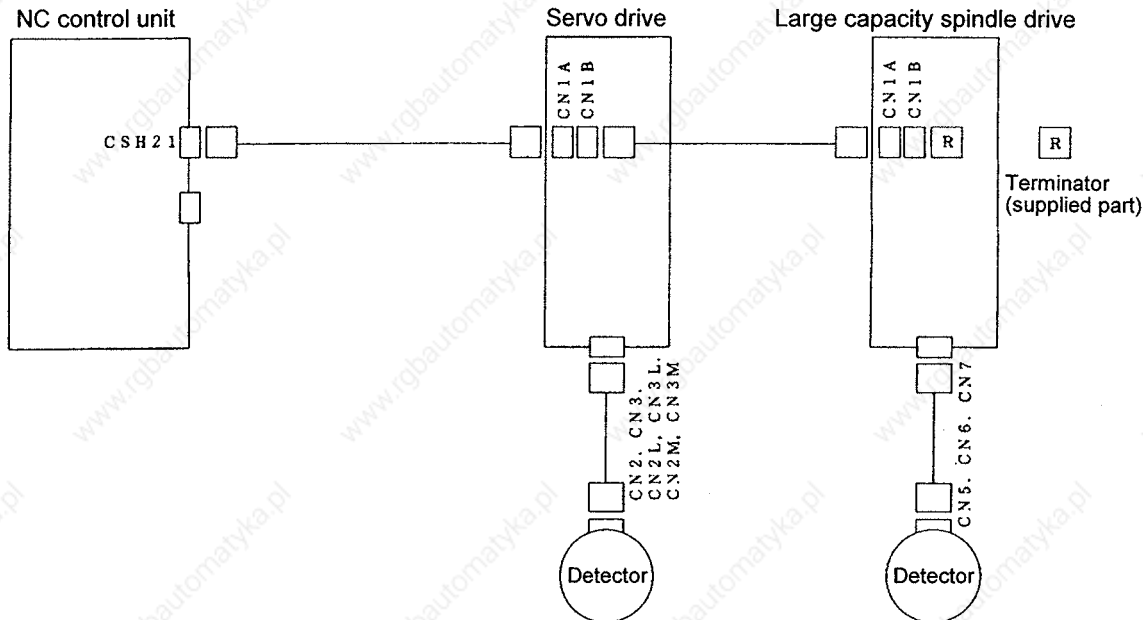

Note. Refer to the Servo/Spindle System Configuration Section, sections 5.1 and 5.2 for the cable list and details on the cable.

Selection of wire size

Select the wires for the power lead-in and spindle motor output according to the large capacity spindle drive unit capacity as shown below instead of by the motor.

| Large capacity spindle drive unit | A-CSP-370/370C | A-CSP-450/450C |
|---|----------------|----------------|
| Power lead-in wire Recommended wire size | HIV50SQ | HIV60SQ |
| Spindle motor output wire Recommended wire size | HIV50SQ | HIV60SQ |

6. Large Capacity Spindle Drive

6.4 Electrical specifications

| | | | |
|---------------------------------|--------------------------------------|--|----------------|
| Type | In-panel installation type | MDS-A-CSP-370 | MDS-A-CSP-450 |
| | Intermediate panel installation type | MDS-A-CSP-370C | MDS-A-CSP-450C |
| Power supply capacity [kVA] | | 54 | 63 |
| Total heating amount [W] (Note) | | 1500 | 1700 |
| Power supply | | 200/200 ~ 230V +10% -15% 50/60Hz ±3Hz | |
| Weight [kg] | In-panel installation type | 78.5 | 101.5 |
| | Intermediate panel installation type | 78.5 | 101.5 |
| Main circuit method | | BiMOS Sinusoidal wave PWM inverter | |
| Control circuit | | Speed feedback with pulse generator, digital closed loop control, vector control | |
| Braking method | | Power supply regenerative braking | |
| Speed fluctuation rate | | 0.2% or less of maximum speed (at load fluctuation of 10 to 100%) | |
| Speed command | | Serial connection with M500 Series CNC | |
| Ambient temperature/humidity | | 0°C to 55°C / 90% or less (with no dew condensation) | |
| Atmosphere | | No toxic gases or dust (environment-resistant JEM1103 grade C compliant) | |
| Vibration | | 4.90/s ² (0.5G) or less | |
| Conformation standards | | IEC | |
| Main circuit wires | Power lead-in wire | HIV50SQ | HIV60SQ |
| | Motor output wire | HIV50SQ | HIV60SQ |

Note. This is the total heating amount during continuous rated operation.
For the intermediate panel type unit, the heating amount outside the panel will be approximately (total heating amount - 120) × 0.7.

Appendix 1. EN Standards Step-down Insulation Transformer

The following transformer is available as an EN Standards step-down insulation transformer. Contact the manufacturer directly to purchase.

- Manufacturer : Nunome Electric

Insulation transformer

Type : NETxxxxTUV
Approval No. : B94 10 21343 002

Standard specifications

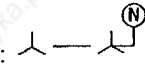
- Rating : Continuous
- Capacity : Refer to following table
- Rated frequency : 50/60Hz
- Primary voltage : 380 400 415
440 460 480V
- Secondary voltage : 200V
- Insulation Class : Class H
- Connection : 
- Max. ambient temperature: 50°C

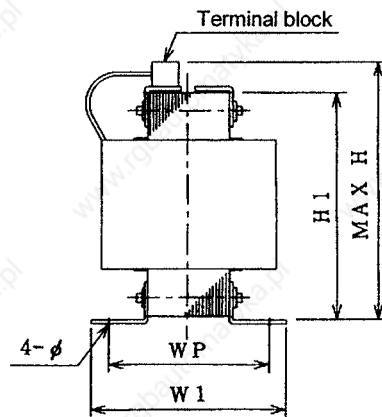
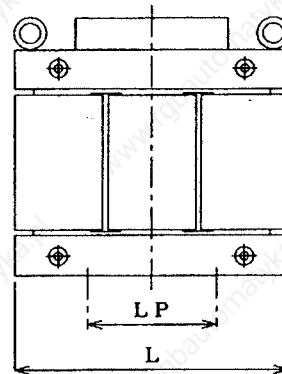
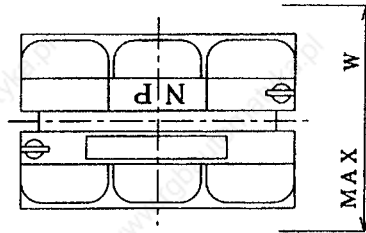
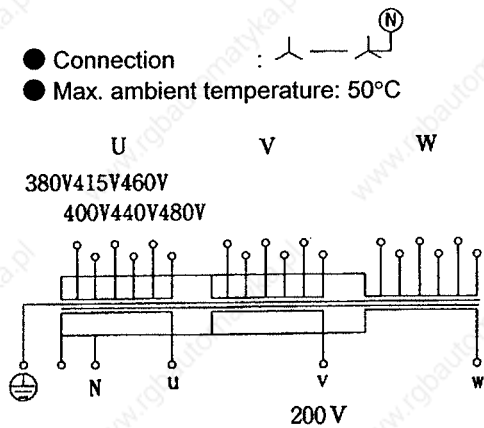

Product outline dimensions

| Type | Capacity | Secondary current (A) | L | LP | W | WP | W1 | H | H1 | ø | kg | Terminal connection wire range (mm ²) |
|--------------|----------|-----------------------|-----|-----|-----|-----|-----|-----|-----|-------|-----|---|
| NET 3460TUV | 3460VA | 10 | 250 | 120 | 210 | 154 | 174 | 310 | 240 | 10×12 | 36 | 0.33 ~ 6 |
| NET 5200TUV | 5200VA | 15 | 320 | 180 | 240 | 153 | 185 | 355 | 285 | 10 | 50 | 0.33 ~ 6 |
| NET 6930TUV | 6930VA | 20 | 360 | 250 | 240 | 160 | 190 | 410 | 340 | 13 | 64 | P0.5 ~ 10 S1.5 ~ 16 |
| NET 010.4TUV | 10.4kVA | 30 | 360 | 250 | 280 | 200 | 230 | 410 | 340 | 13 | 93 | 1.5 ~ 16 |
| NET 013.9TUV | 13.9kVA | 40 | 500 | 330 | 300 | 205 | 245 | 455 | 370 | 13×15 | 120 | 2.5 ~ 16 |
| NET 017.3TUV | 17.3kVA | 50 | 500 | 330 | 330 | 225 | 265 | 455 | 370 | 13×15 | 143 | 2.5 ~ 16 |
| NET 026TUV | 26kVA | 75 | 530 | 305 | 400 | 222 | 280 | 535 | 450 | 13 | 206 | P2.5 ~ 16 S6 ~ 50 |
| NET 034.6TUV | 34.6kVA | 100 | 550 | 270 | 440 | 305 | 355 | 575 | 490 | 13 | 273 | P2.5 ~ 16 S6 ~ 50 |

Appendix 2. EMC Installation Guidelines

1. Introduction

EMC Instructions became mandatory as of January 1, 1996. The subject products must have a CE mark attached indicating that the product complies with the Instructions. As the NC unit is a component designed to control machine tools, it is believed that it is not a direct EMC Instruction subject. Thus, the CE mark will not be attached to our NC units. However, we would like to introduce the following measure plans to backup EMC Instruction compliance of the machine tool as the NC unit is a major component of the machine tools.

- (1) Measure plans to suppress radiation obstruction to external sources, assuming that the unit is installed in a control panel.
- (2) Instruction of a noise filter (line filter, ferrite core, etc.) for EMC measures.
Mitsubishi is carrying out tests to confirm the compliance to the EMC Standards under the environment described in this manual. However, the level of the noise from the power supply line or from in-air conveyance will differ according to the equipment type and layout, control panel structure and wiring lead-in, etc. Thus, we ask that the final noise level be confirmed by the machine manufacturer.

These contents are the same as the EMC INSTALLATION GUIDELINES (BNP-B8582-45-A).

2. EMC

The EMC Instructions largely regulate the following two withstand levels.

- (1) Emission..... Capacity to prevent output of obstructive noise that adversely affects external sources.
- (2) Immunity..... Capacity to not malfunction due to obstructive noise from external source.

The details of each level are classified below. It is assumed that the Standards and test details required for a machine tool are the same as these.

| Class | Name | Details | Generic Standard | Standards for determining test and measurement |
|----------|---|---|---------------------------------------|--|
| Emission | Radiated noise | Electromagnetic noise radiated through the air | EN50081-2 (Industrial environment) | EN55011 |
| | Conductive noise | Electromagnetic noise discharged from power supply line | | |
| Immunity | Static electricity electrical discharge | Example) Noise from a charged human body | EN50082-2 (Industrial environment) | EN61000-4-2 |
| | Radiated magnetic field | Example) Electromagnetic noise from wireless transmitters or broadcasting companies, etc. | | ENV50140 |
| | Burst wave noise | Example) Relay noise or electromagnetic noise caused by live electricity being turned on or off | | EN61000-4-4 |
| | Conductive immunity | Example) Electromagnetic noise flowed from power supply wires or earthing wires, etc. | | ENV50141 |
| | Power supply frequency field | Example) Electromagnetic noise of 50/60Hz power supply frequency | | EN61000-4-8 |

3. EMC Measures

The main items relating to EMC measures include the following.

- (1) Store the device in an electrically sealed metal panel.
- (2) Earth all conductors that are floating electrically.
- (3) Lengthen the distance between the noise source and partner device. Store the noise source independently in a panel.
- (4) Insulate the circuit so that noise is not conducted.
- (5) Shield the input/output wires (motor feedback cable, drive cable, etc.)
- (6) Install a noise filter.

Note that the electromagnetic noise radiated in the air is greatly affected by the clearance of the panel and the quality of the cable shield.

4. Measures for panel structure

The design of the panel is a very important factor for the EMC measures, so take the following measures into consideration.

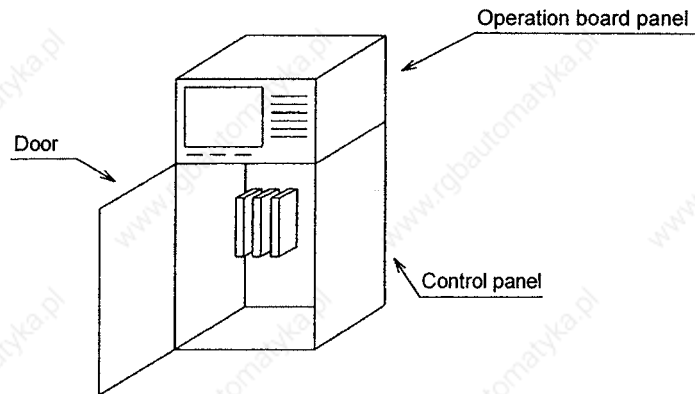

4.1 Measures for control panel unit

- (1) Use metal for all materials configuring the panel.
- (2) For the joining of the top plate and side plates, etc., mask the contact surface with paint, and fix with welding or screws.

In either case, keeping the joining clearance to a max. of 10cm for a better effect.

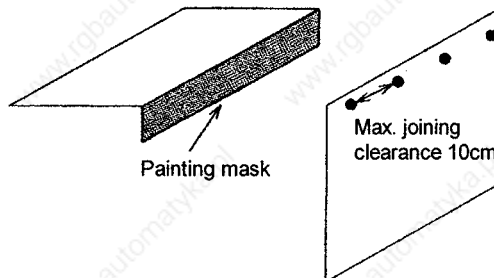

- (3) Note that if the plate warps due to the screw fixing, etc., by that creating a clearance, noise could leak from that place.
- (4) Plate (nickel, tin) the metal plate surface at the earthing section, such as the earthing plate.
- (5) The max. tolerable hole diameter of the openings on the panel surface, such as the ventilation holes, must be 3cm to 5cm. If the opening exceeds this tolerance, use a measure to plug it. Note that even when the clearance is less than 3cm to 5cm, noise may still leak if the clearance is long.

Example)

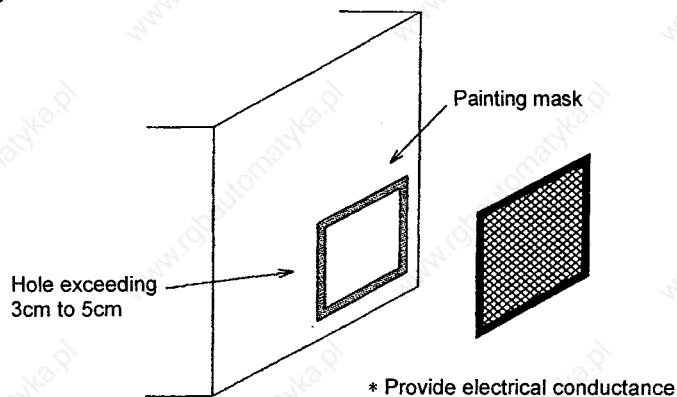

4.2 Measures for door

- (1) Use metal for all materials configuring the door.
- (2) Use an EMI gasket or conductive packing for the contact between the door and control panel unit.

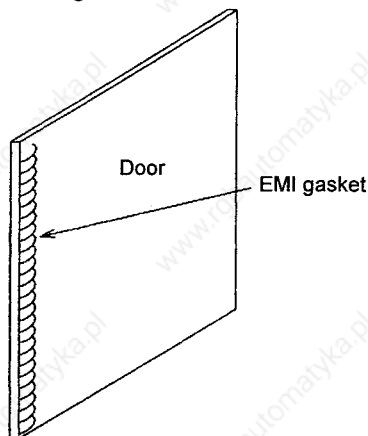

- (3) The EMI gasket or conductive packing must contact a uniform and correct position of the metal surface of the control panel unit.
- (4) The surface of the control panel unit contacted by the EMI gasket or conductive packing must have conductance treatment.

Example) Weld (or screw) a welded plate that is plated (nickel, tin).

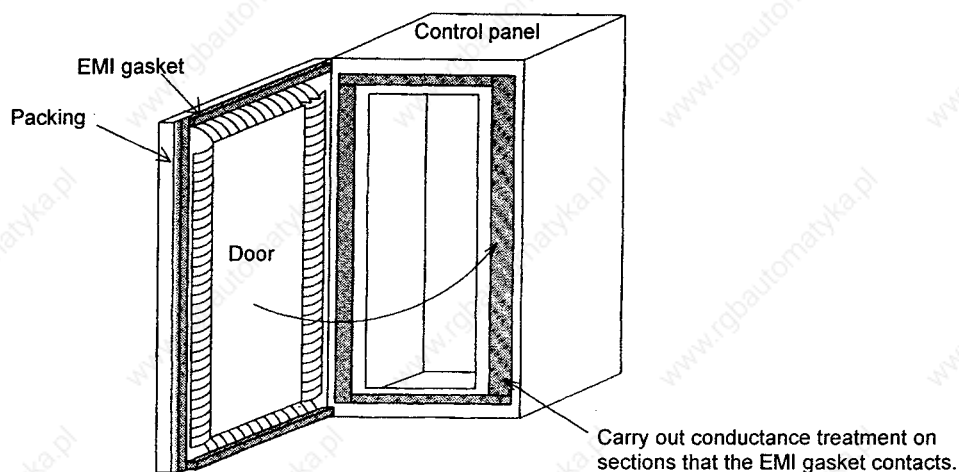

- (5) As a method other than the above, the control panel unit and door can be connected with a plain stitch wire. In this case, the panel and door should be contacted at as many points as possible.

4.3 Measures for operation board panel

- (1) Always connect the operation board and indicator with an earthing wire.
- (2) If the operation board panel has a door, use an EMI gasket or conductive packing between the door and panel to provide electrical conductance in the same manner as the control panel.
- (3) Connect the operation board panel and control panel with a sufficiently thick earthing wire.

4.4 Shielding of input power supply section

- (1) Separate the input power supply section from other parts of the control panel so that the input power supply cable will not be contaminated by radiated noise.

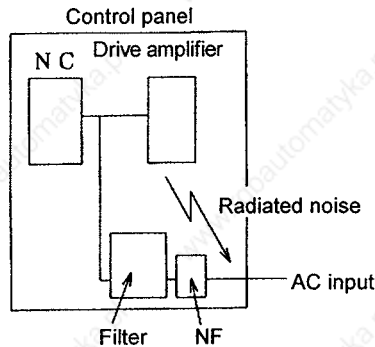

The power supply line noise is eliminated by the filter, but cable contains noise again because of the noise radiated in the control panel.

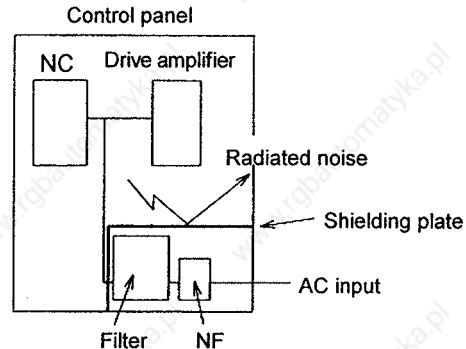

Use a metal plate, etc., for the shielding partition. Make sure not to create a clearance.

5. Measures for various cables

The various cables act as antennas for the noise, and thus appropriate treatment is required to discharge the noise externally. The wiring between the drive amplifier and motor act as an extremely powerful noise source, so apply the following measures.

5.1 Measures for wiring in panel

- (1) If the cables are led unnecessary in the panel, they will be contaminated by noise. Thus, keep the wiring length as short as possible.

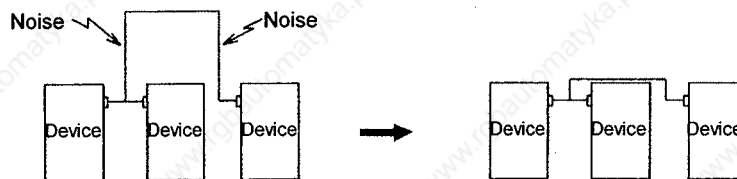

- (2) The noise from other devices will enter the cable and be discharged externally, so avoid internal wiring near the openings.

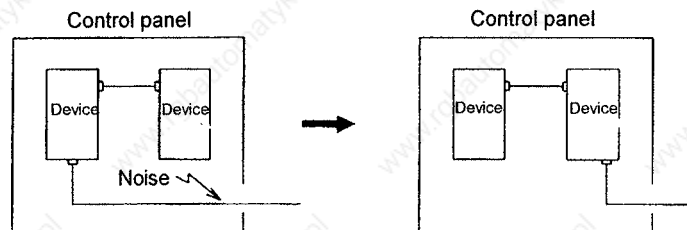

- (3) Connect the control device earthing terminal and earthing plate with a thick wire. Take care to the leading of the wire as with the above items.

5.2 Measures for shield treatment

Use the shield clamp enclosed with the Mitsubishi NC unit for the shield treatment. Refer to the "Connection Manual" for details.

NC section

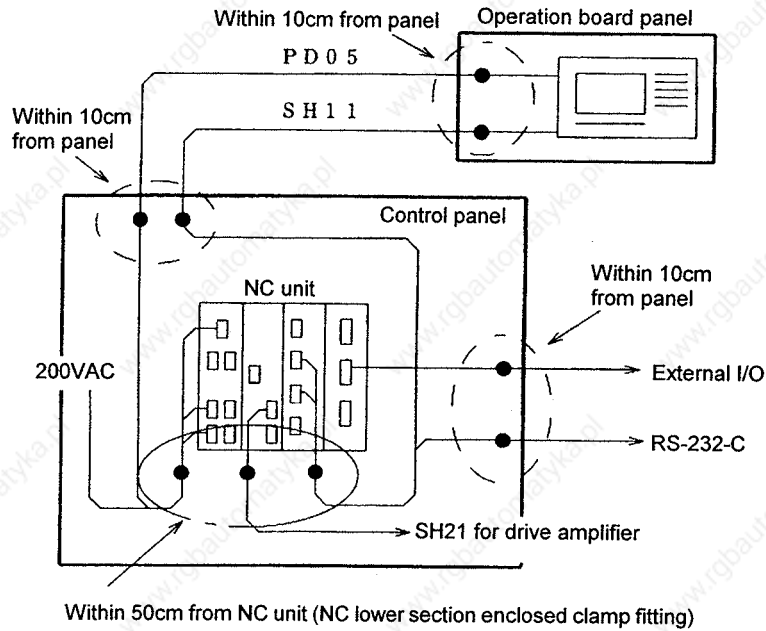

Drive section

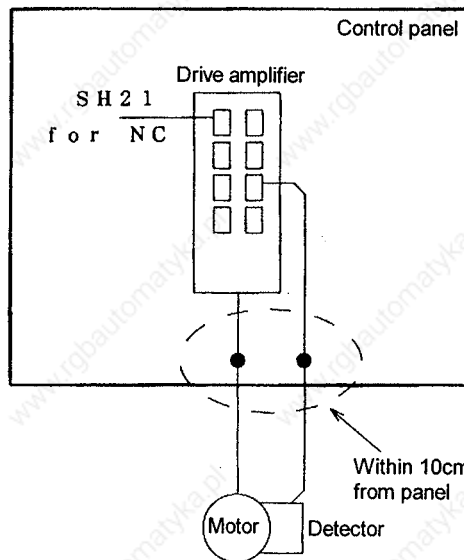

5.3 Servomotor power cable

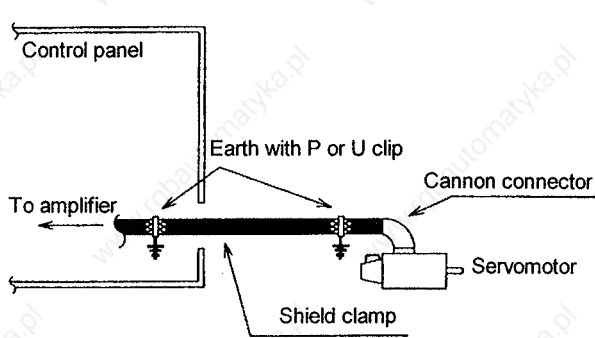

Using shield cable

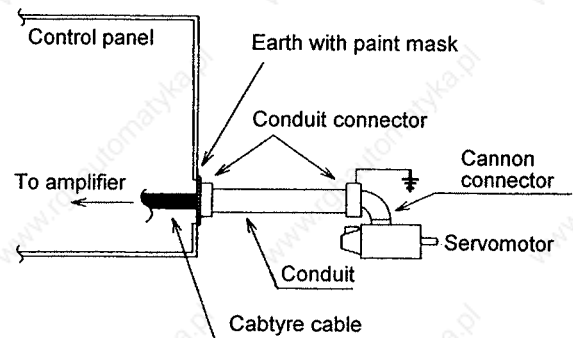

Using conduit

- (1) Use four wires (3-phase + earthing) for the power cable, and use a cable that is completely shielded and that has no relay wires.
- (2) Earth the shield on both the control panel side and motor chassis side.
- (3) Earth the shield with a metal P clip or U clip.
- (4) Directly earth the shield. Do not solder the shield onto a wire and earth the end.

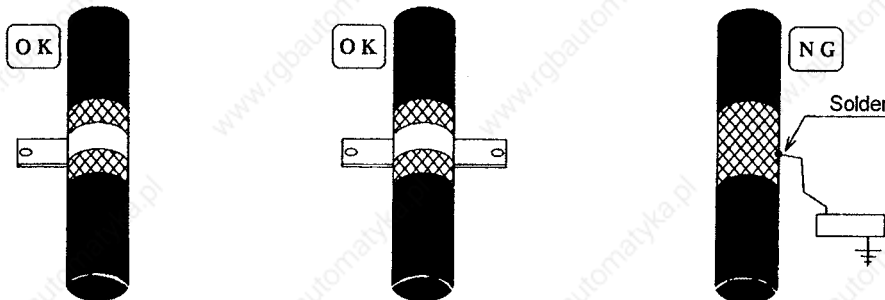

- (5) When not using a shield cable for the power cable, use a conventional cabtyre cable. Use a metal conduit outside the cable.
- (6) Earth the power cable on the control panel side with the conduit connector and control panel side wall. (Mask the side wall of the control panel with paint.)
- (7) Use the type of treatment shown in the example for the conduit connector to earth the power cable on the motor side. (Example: Use a clamp fitting, etc.)

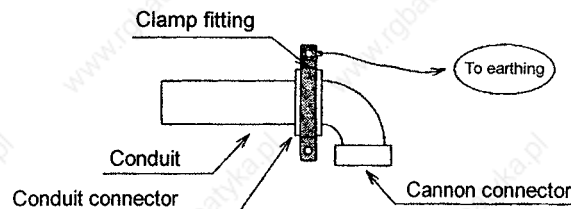

5.4 Servomotor feedback cable

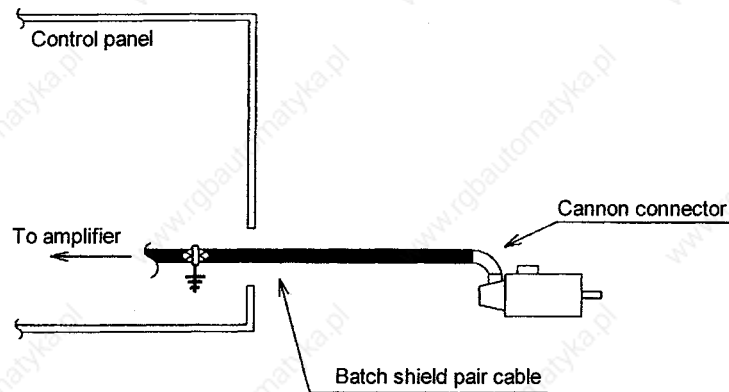

- (1) Use the conventional batch pair shield cable for the servomotor's feedback cable. Earth on the NC side (control panel side).

5.5 Spindle motor power cable

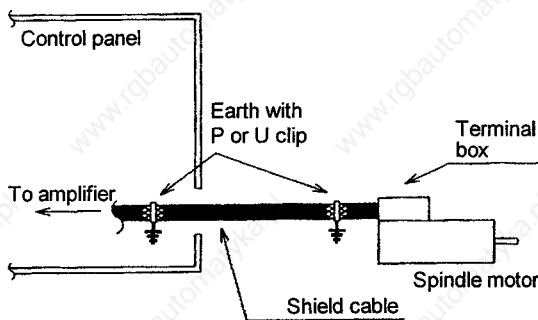

Using shield cable

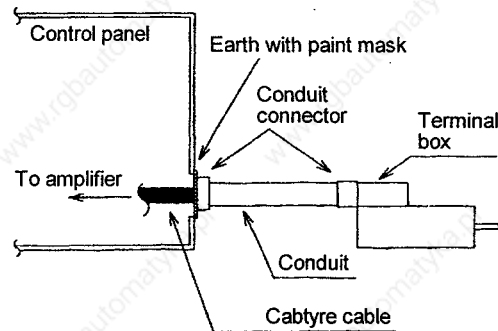

Using conduit

- (1) Use four wires (3-phase + earthing) for the power cable, and use a cable that is completely shielded and that has no relay wires.
- (2) Earth the shield with the same manner as the servomotor power cable.
- (3) When not using a shield cable for the power cable, use a conventional cabletyre cable. Use a metal conduit outside the cable.
- (4) Earth the power cable on the control panel side with the conduit connector and control panel side wall in the same manner as the servomotor power cable. (Mask the side wall of the control panel with paint.)
- (5) Earth with the conduit connector section in the same manner as the servomotor drive cable.

5.6 Spindle motor feedback cable

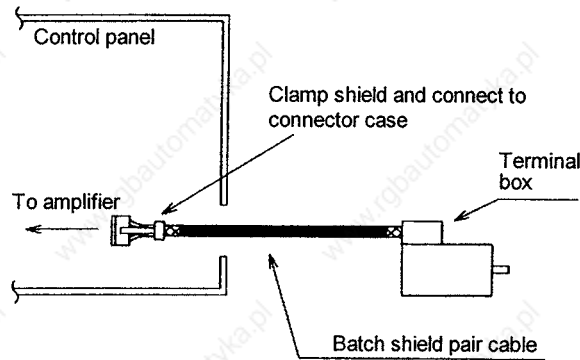

- (1) Use the conventional batch pair shield cable for the spindle motor's feedback cable.

Note) The shield of the spindle motor feedback cable is an AG (Analog Ground), so do not earth it.

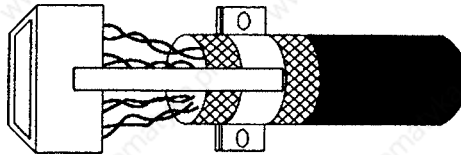

Spindle amplifier side connector (View of state with cover removed)

5.7 Cable between control panel and operation board panel

- (1) Use a shield cable for the cable between the control panel and operation board.
- (2) Earth the shield in the same manner as the other cables.
- (3) Insert a ferrite core in the SH11 cable at a position within 10cm from the device.
(This provides a better effect.)

SH11 cable (signal cable)

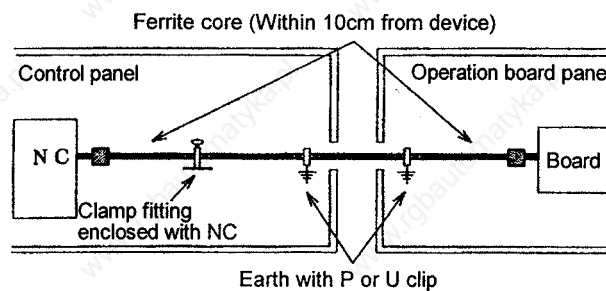

PO5 cable (power supply cable)

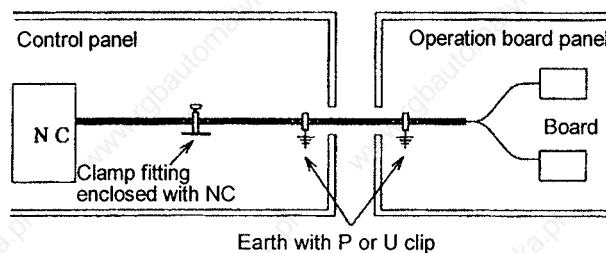

6. Measures for noise filter

The power supply line filter is an indispensable part for conductive noise measures, so always use one taking the following measures into consideration.

6.1 Measures in panel

- (1) If the power supply line filter's input and output wires are close, the noise from the contaminated output wire will be conveyed through the air and contaminate the input wire. Thus, always separate and wire (30cm or more) the input and output wires of the filter.

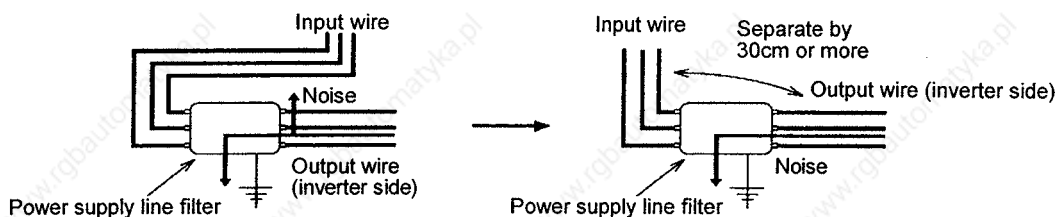

- (2) Install the power supply line filter directly onto the metal surface of the control panel opening that has been masked with paint.

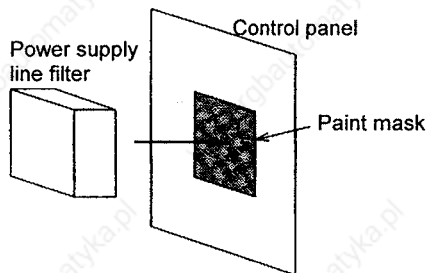

- (3) Do not lead the input wire in the panel without passing through the filter. Use a shield cable when the wire must be led.

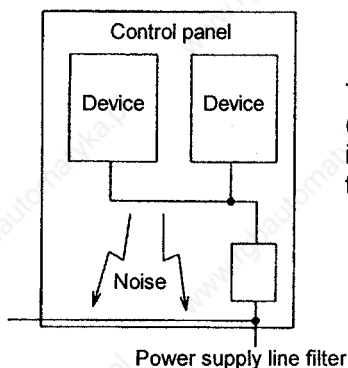

The noise from other devices (cables) will contaminate the input wire that does not pass the filter.

- (4) Insertion of a noise filter between the motor and drive amplifier is also an effective measure. The precaution points regarding the wiring and installation are the same as for the power supply line filter.

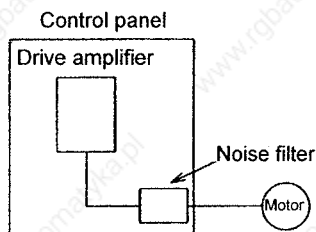

Appendix 2 EMC Installation Guidelines

6.2 Precautions for using ferrite core

- (1) Install the ferrite core on the NC/drive section signal wire. The installation place must be within 10cm from the device.

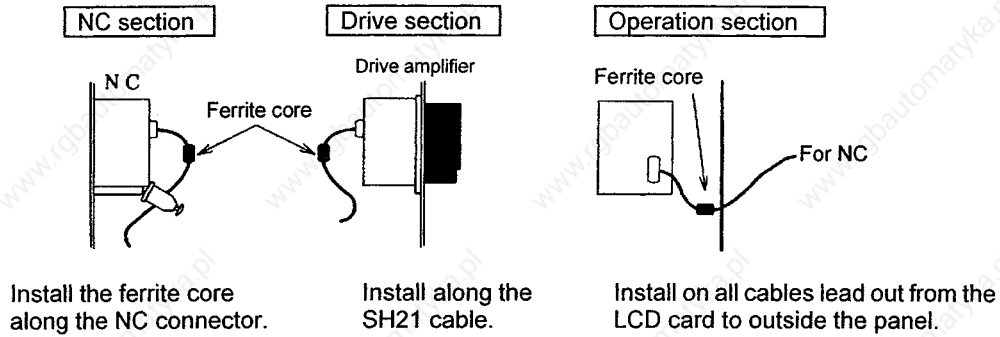

6.3 Mitsubishi recommended parts

Mitsubishi recommends the following parts for EMC measures.

| Noise measure enforcement place | | Measure part | Recommended part | Remarks |
|---|------------|--------------------------|--------------------------------------|------------------|
| Input power supply section | | Power supply line filter | Soshin Electric HF30□□A-TM Series | Attached catalog |
| Drive amplifier output section | | Noise filter | Soshin Electric CC30□□C-AZ Series | |
| Machine side inductive electric parts (relay, etc.) | AC circuit | CR snubber circuit | / | / |
| | DC circuit | Diode | | |
| Signal wire | | Ferrite core | TDK ZACT Series | Attached catalog |

HF3000A-TM/HF3000C-TM Series

- 3-phase, 3-wire type (250V system, 500V system)
- Noise Standards [German Official Report Vfg243, European Standards EN55011 (Class B)] compatible part.
- Effective as an IGBT inverter and MOS-FET inverter.
- Installation is easy with terminal block structure, and reliability is outstanding.

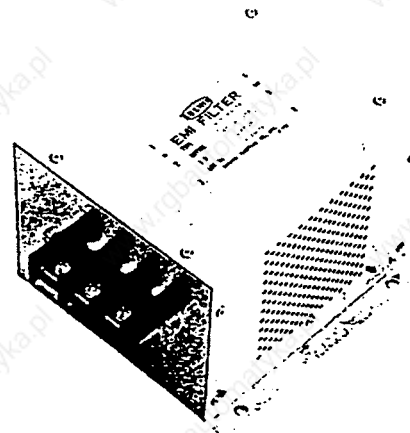

<Application>

- Products that must clear Noise Standards [German Official Report Vfg243, European Standards EN55011 (Class B)].
- For input of electricity converter using advanced high-speed power device such as IGBT MOS-FET.

<Performance>

<250V system>

| Part name | HF3005A-TM | HF3010A-TM | HF3015A-TM | HF3020A-TM | HF3030A-TM | HF3040A-TM | HF3050A-TM | HF3060A-TM | HF3080A-TM | HF3100A-TM |
|-----------------|-----------------------|------------|------------|------------|------------|------------|------------|------------|------------|------------|
| Rated voltage | 250VAC | | | | | | | | | |
| Rated current | 5A | 10A | 15A | 20A | 30A | 40A | 50A | 60A | 80A | 100A |
| Leakage current | 1.5mA Max 250VAC 60Hz | | | | | | | | | |

<500V system>

| Part name | HF3005-TM | HF3010-TM | HF3015-TM | HF3020-TM | HF3030-TM | HF3040-TM | HF3050-TM | HF3060-TM | HF3080-TM | HF3100-TM |
|-----------------|---------------------|-----------|-----------|-----------|-----------|-----------|-----------|-----------|-----------|-----------|
| Rated voltage | 500VAC | | | | | | | | | |
| Rated current | 5A | 10A | 15A | 20A | 30A | 40A | 50A | 60A | 80A | 100A |
| Leakage current | 3mA Max 500VAC 60Hz | | | | | | | | | |

<Noise terminal voltage measurement example> Measured with IGBT inverter

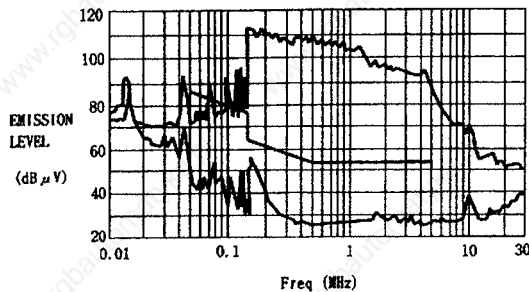

German Official Report Vfg243 measurement data

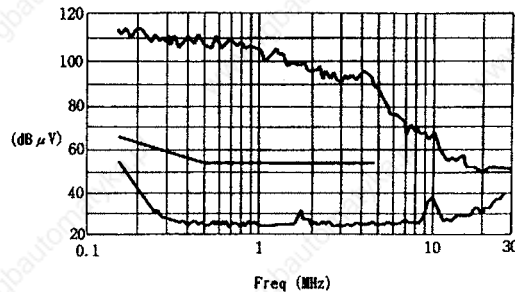

European Standards EN55011 Class B measurement data

Appendix 2 EMC Installation Guidelines

<Main characteristics>

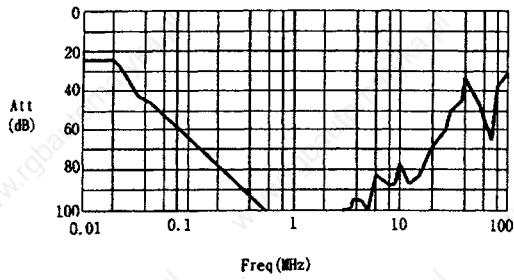

<Circuit diagram>

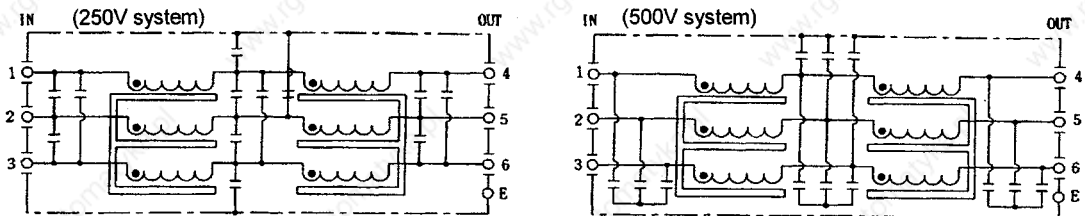

Appendix 2 EMC Installation Guidelines

<Outline dimensions>

| Part name | Dimensions (unit: mm) | | | Part name | Dimensions (unit: mm) | | |
|------------|-----------------------|-----|-----|------------|-----------------------|-----|-----|
| | A | B | C | | A | B | C |
| HF3005A-TM | 175 | 170 | 130 | HF3005C-TM | 170 | 170 | 150 |
| HF3010A-TM | | | | | | | |
| HF3015A-TM | | | | | | | |
| HF3020A-TM | | | | | | | |
| HF3030A-TM | 260 | 155 | 140 | HF3030C-TM | 260 | 155 | 160 |
| HF3040A-TM | | | | | | | |
| HF3050A-TM | 290 | 190 | 230 | HF3050C-TM | 290 | 190 | 250 |
| HF3060A-TM | | | | | | | |
| HF3080A-TM | 405 | 220 | 240 | HF3080C-TM | 405 | 220 | 260 |
| HF3100A-TM | | | | | | | |

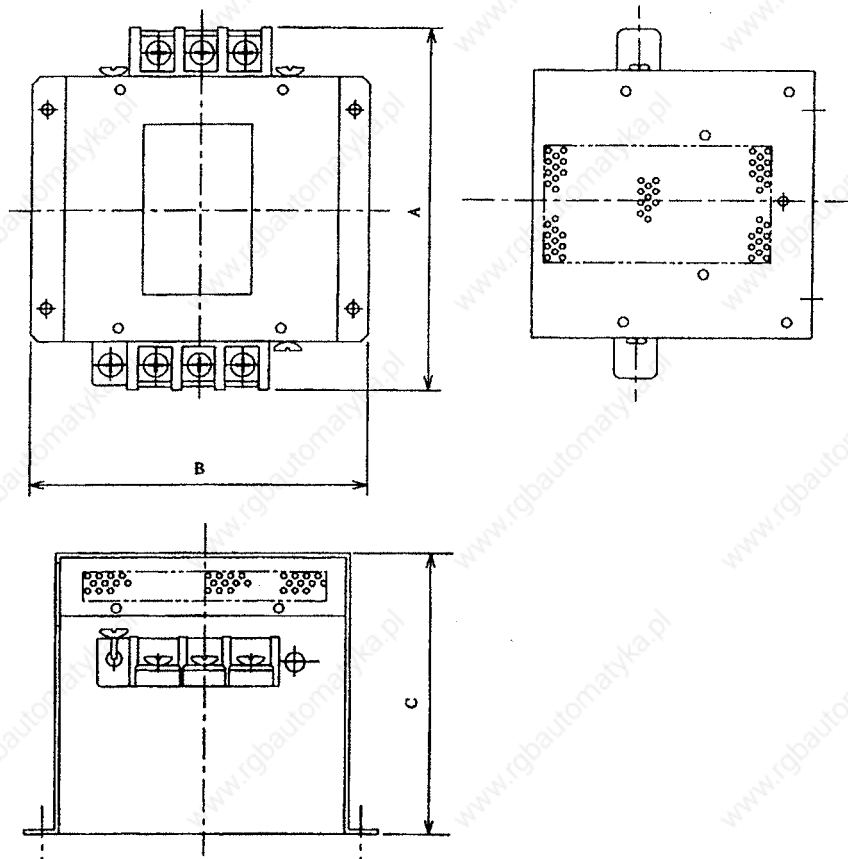

CC3000C-AZ Series Terminal block type

- 3-phase, 3-wire type (500V system)
- Dedicated reactor type for inverter secondary side (load side).
- Noise radiated on the inverter output side is dampened.
- Series is available up to 150A.

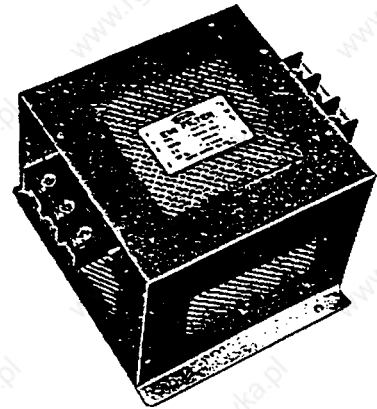

<Application>

- For secondary side (load side) of general-purpose and large capacity inverter powers.

<Performance> (500V system)

| Part name | CC3005C-AZ | CC3010C-AZ | CC3015C-AZ | CC3020C-AZ | CC3030C-AZ | CC3040C-AZ | CC3050C-AZ | CC3060C-AZ | CC3080C-AZ | CC3100C-AZ | C3115C-AZ | CC3150C-AZ |
|---------------|------------|------------|------------|------------|------------|------------|------------|------------|------------|------------|-----------|------------|
| Rated voltage | 500VAC | | | | | | | | | | | |
| Rated current | 5A | 10A | 15A | 20A | 30A | 40A | 50A | 60A | 80A | 100A | 115A | 150A |

<Main characteristics>

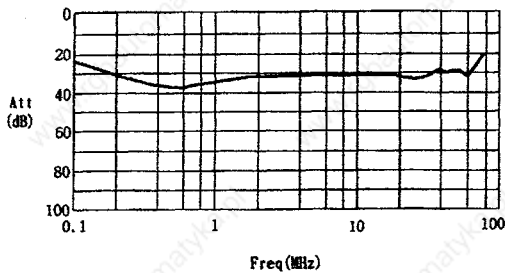

<Circuit diagram>

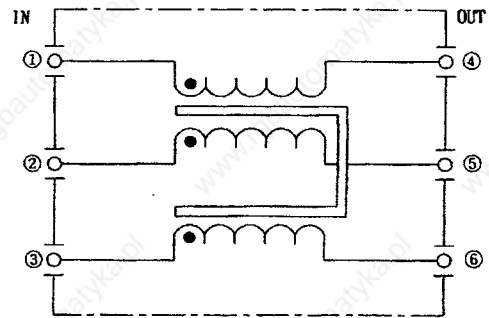

<Outline dimensions>

| Part name | Dimensions (Unit: mm) | | | | | | | | | | | |
|------------|-----------------------|-----|-----|-----|-----|----|----|----|----|----|------|----------|
| | A | B | C | D | E | F | G | H | J | L | N | P |
| CC3005C-AZ | 154.5 | 140 | 125 | 110 | 95 | 70 | | 50 | 20 | | | R2.25 |
| CC3010C-AZ | | | | | | | 32 | | | | | |
| CC3015C-AZ | | | | | | | | | | M4 | ø4.5 | length 6 |
| CC3020C-AZ | 174.5 | 160 | 145 | 130 | 110 | 80 | | 70 | 25 | | | |
| CC3030C-AZ | | | | | | | | | | | | |

| Part name | Dimensions (Unit:mm) | | | | | | | | | | |
|------------|----------------------|-----|-----|-----|-----|-----|----|-----|-----|----|------|
| | A | B | C | D | E | F | G | H | J | L | N |
| CC3035C-AZ | 170 | 120 | 80 | 150 | 135 | 120 | 44 | 120 | 90 | M5 | ø5.5 |
| CC3045C-AZ | | | | | | | | | | | |
| CC3060C-AZ | 230 | 180 | 100 | 220 | 200 | 180 | 44 | 170 | 140 | M6 | ø6.5 |
| CC3080C-AZ | | | | | | | | | | | |
| CC3100C-AZ | 260 | 210 | 150 | 250 | 230 | 210 | 57 | 170 | 140 | M8 | ø6.5 |
| CC3115C-AZ | | | | | | | | | | | |
| CC3150C-AZ | 277 | 220 | 160 | 260 | 240 | 220 | 57 | 170 | 140 | M8 | ø6.5 |

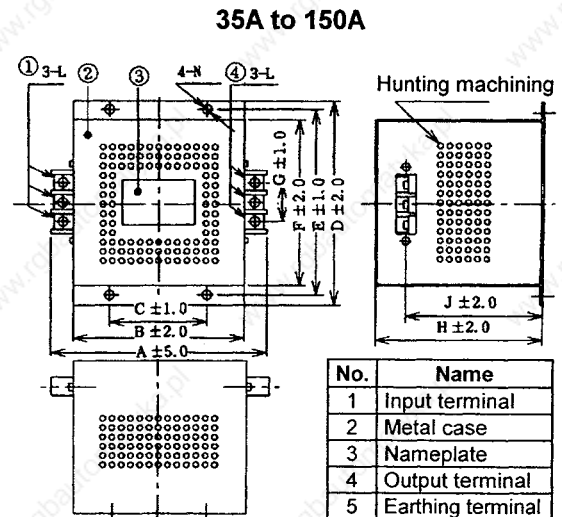
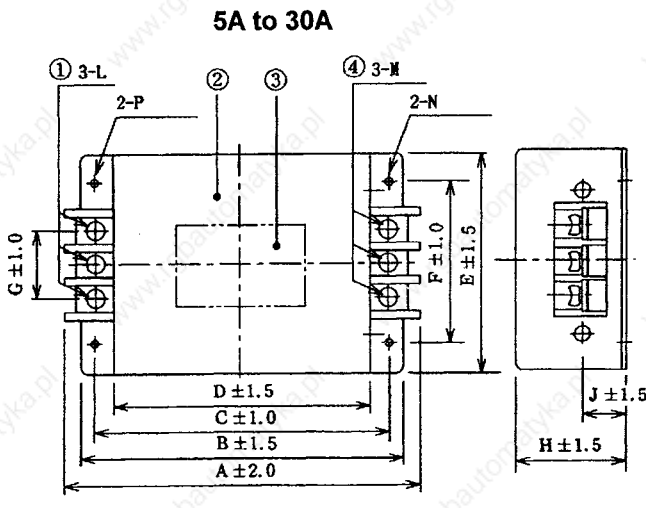

Product Identification

ZCAT 20 35 - 09 30 A - BK
(1) (2) (3) (4) (5) (6) (7)

- (1) Series name
- (2) Outside diameter in mm
- (3) Length in mm
- (4) Inside diameter in mm
- (5) Material
- (6) A : Self-hold (cable-rock mechanism) type
B : Self-hold (chassis-hold mechanism) type
None : Band-hold type
- (7) Color BK : Black
None : Gray

Construction

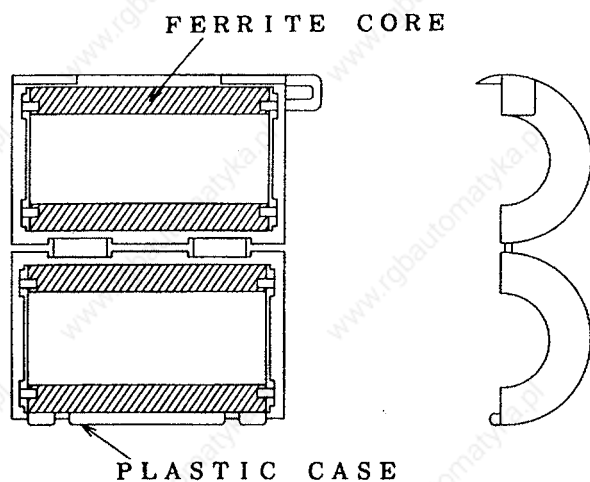

Appendix 3. Unit Systems

The correspondence of the conventional unit symbols used in this manual and the international unit system (SI) is shown below.

| Name of mass | Conventional unit symbol | SI unit and unit symbols which can be used in combination | Conversion value |
|---|---------------------------|---|--|
| Weight/load (to express mass) | kgf | _____ | The numerical value is the same |
| Mass | _____ | kg | |
| Weight/load (to express concept of force) | kgf | N | 1 kgf = 9.80665N |
| Force | kgf | N | 1 kgf = 9.80665N |
| Torque | kgf • cm | N • m | 1 kgf•cm = 9.80665 × 10 ⁻² N•m |
| Inertia (J) | kgf • cm • S ² | kg • m ² | 1kgf•cm•S ² = 9.80665 × 10 ⁻² kg•m ² |
| GD ² | kgf • cm ² | _____ | $J = \frac{GD^2}{4g}$ (g: Acceleration of gravity 980cm/s ²) |
| Rotation speed • Speed | rpm | r/min • min ⁻¹ | 1rpm = 1r/min = 1min ⁻¹ |

I. Precautions for Installation in UL/c-UL Applications

1. General precautions

The discharge time of the main circuit capacitor is approximately 10 minutes. Turn the power OFF and wait at least 15 minutes before starting wiring or investigations to prevent electric shock accidents.

2. Installation

The MDS-B Series is designated for installation in a panel. Design the capacity of the panel so that the total capacity of each MDS-B Series unit in the panel is 150% or more, and the temperature in the panel does not exceed 55°C. (Refer to Chapter 1 sections 3 and 7 in the Specifications Manual.)

3. Short-circuit rating

The UL short-circuit test has been carried out for the MDS-B Series with an AC circuit having a peak current limited to 5000A or less. The circuit is compatible with this rating.

4. Peripheral devices

Select peripheral devices compliant with the UL/c-UL Standards.

- The NFB, fuse, magnetic contactor and AC reactor are shown below for reference.

| Applicable power supply unit | NFB | Fuse Class K5 | Magnetic contactor (AC3) | AC reactor BKO-NC6851- |
|------------------------------|------------|---------------|--------------------------|------------------------|
| MDS-B-CVE-37 | NF50 40A | 70A | S-N25 | H11 (B-AL-7.5K) |
| MDS-B-CVE-55 | NF50 40A | 100A | S-N25 | H11 (B-AL-7.5K) |
| MDS-B-CVE-75 | NF50 40A | 100A | S-N25 | H11 (B-AL-7.5K) |
| MDS-B-CVE-110 | NF50 50A | 100A | S-N35 | H12 (B-AL-11K) |
| MDS-B-CVE-150 | NF100 100A | 200A | S-N50 | H13 (B-AL-18.5K) |
| MDS-B-CVE-185 | NF100 100A | 200A | S-N50 | H13 (B-AL-18.5K) |
| MDS-B-CVE-220 | NF225 150A | 200A | S-N80 | H14 (B-AL-30K) |
| MDS-B-CVE-260 | NF225 150A | 300A | S-N80 | H14 (B-AL-30K) |
| MDS-B-CVE-300 | NF225 150A | 300A | S-N80 | H14 (B-AL-30K) |
| MDS-B-CVE-370 | NF225 175A | 300A | S-N150 | H15 (B-AL-37K) |

- Circuit breaker for spindle motor fan
Select the circuit breaker for the spindle motor fan using a value approximately double the rated current as a guideline.
(A current approximately double the rated current will flow when the fan is started.)

Caution:

- For installation in United States, branch circuit protection must be provided, in accordance with the National Electrical Code and any applicable local codes.
- For installation in Canada, branch circuit protection must be provided, in accordance with the Canada Electrical Code and any applicable provincial codes.

5. Servomotor installation

Install the servomotor on a flange having the size shown below, or on a flange having a cooling performance equal or more than the following flanges.

| Flange size (mm) | Servomotor | | | | |
|------------------|--------------|--------------|------------|------------|--------------|
| | HC-□ | HC-RF□ | HC-MF□ | HA-FF□ | HC-SF□ |
| 150 × 150 × 6 | – | – | under 100W | under 100W | – |
| 250 × 250 × 6 | – | – | 200W | 200, 300W | – |
| 250 × 250 × 12 | 0.5 to 1.5kW | 1.0 to 2.0kW | 400W | 400, 600W | 0.5 to 1.5kW |
| 300 × 300 × 12 | – | – | 750W | – | – |
| 300 × 300 × 20 | 2.0 to 7.0kW | – | – | – | 2.0 to 7.0kW |

6. Motor overload protection

The servo drive unit MDS-B-V1/2/14/24 Series and spindle drive unit MDS-B-SP Series each have an electronic motor overload protection circuit.

Refer to the following tables for details on adjusting the motor overload.

6.1 MDS-B-V1/2/14/24

| Parameter No. | Parameter abbrev. | Parameter name | Setting outline | Standard setting value | Setting range |
|---------------|-------------------|--------------------------|---|------------------------|-----------------|
| SV021 | OLT | Overload time constant | Set the overload detection time constant. (1-sec. unit) | 60 (sec.) | 1 to 300 (sec.) |
| SV022 | OLL | Overload detection level | Set the overload current detection level as a percentage (%) of the stall rating. | 150 (%) | 1 to 500 (%) |

6.2 MDS-B-SP

| Parameter No. | Parameter abbrev. | Parameter name | Setting outline | Standard setting value | Setting range |
|---------------|-------------------|--------------------------|---|------------------------|------------------|
| SV063 | OLT | Overload time constant | Set the overload detection time constant. (1-sec. unit) | 60 (sec.) | 1 to 1000 (sec.) |
| SV064 | OLL | Overload detection level | Set the overload current detection level as a percentage (%) of the rating. | 110 (%) | 1 to 200 (%) |

7. Unit connection

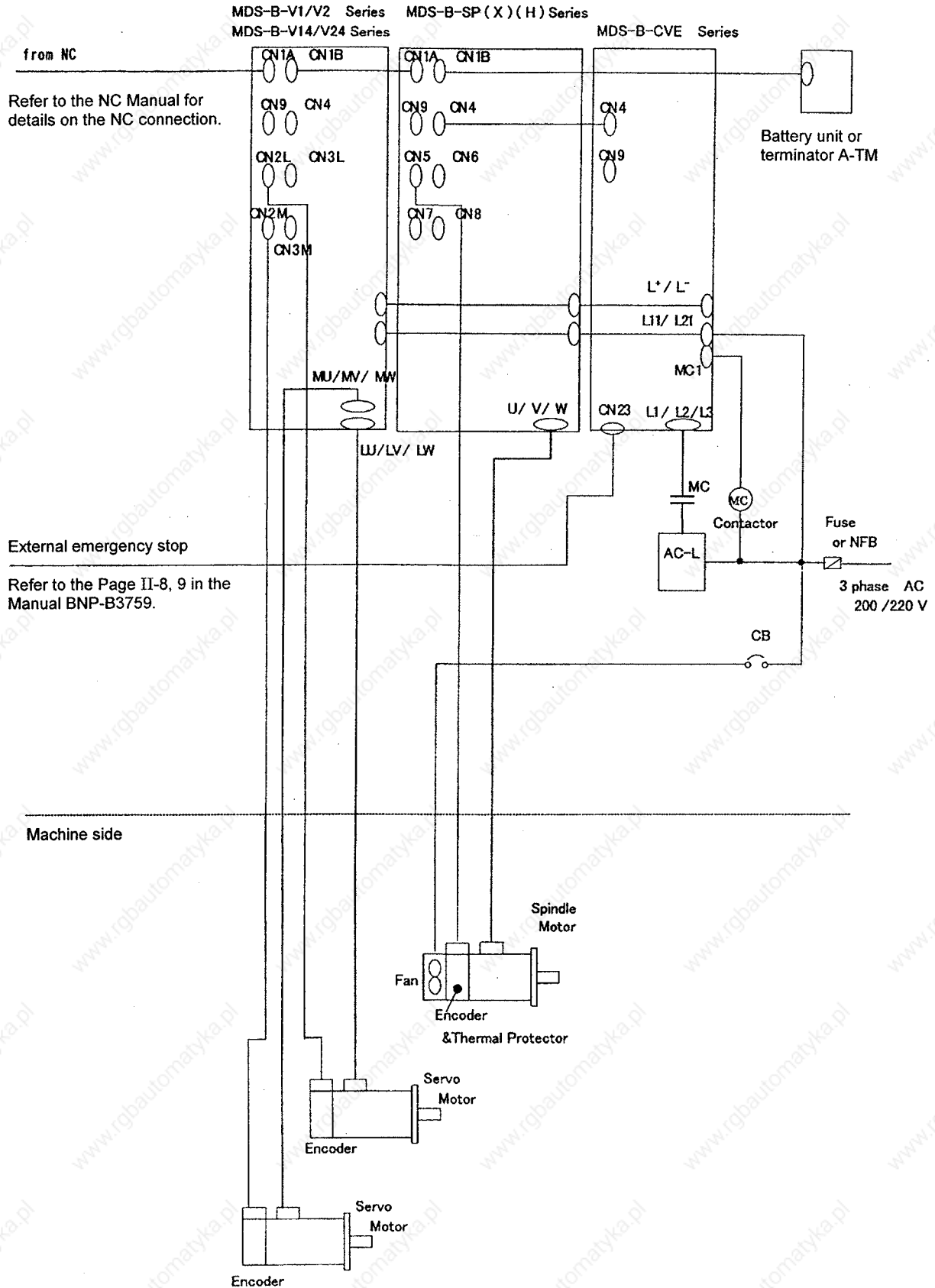

8. External wiring

Use the UL-recommended round crimp terminal for the input/output wiring, and use the terminal maker-designated tool for crimping.

The crimp terminal and crimping tool for J.S.T. Mfg. Co., Ltd. are shown below for reference.

8.1 Power supply unit

| Capacity [kW] | | 3.7 to 7.5 | 11.0 | 15.0 to 18.5 | 22.0 to 37.0 |
|----------------|-------------------------------------|------------|-----------|--------------|--------------|
| Terminal block | P, N (L+, L-) | M6 | M6 | M6 | M6 |
| | Screw tightening torque [lb in/N·m] | 44.3/5.0 | 49.6/5.6 | 49.6/5.6 | 49.6/5.6 |
| | L11, L21 (R0, S0), MC1 | M4 | M4 | M4 | M4 |
| | Screw tightening torque [lb in/N·m] | 17.4/2.0 | 7.8/0.88 | 7.8/0.88 | 7.8/0.88 |
| | L1, L2, L3 | M4 | M5 | M5 | M8 |
| | Screw tightening torque [lb in/N·m] | 14.6/1.6 | 29.8/3.37 | 29.8/3.37 | 117.2/13.2 |

P, N (L+, L-)

| Capacity [kW] | 3.7, 5.5 | 7.5 | 11.0 | 15.0 | 18.5, 22.0 | 26.0 | 30.0 | 37.0 |
|--|----------|----------|---------|---------|------------|---------|-----------------|-----------------|
| Wire size (AWG)/ temperature rating Note 1 | #11/60°C | #9/60°C | #5/60°C | #5/60°C | #3/60°C | #1/60°C | #2/0/60°C | #2/0/60°C |
| | #14/75°C | #11/75°C | #8/75°C | #5/75°C | #5/75°C | #3/75°C | #1/75°C | #1/0/75°C |
| Crimp terminal | 3.5-6 | R5.5-6 | R14-6 | R14-6 | R22-6 | 38-S6 | L330T 459-12 | L330T 459-12 |
| | R2-6 | 3.5-6 | R8-6 | | R14-6 | R22-6 | 38-S6 | |
| Crimping tool | YHT-2210 | | YHT-14S | YHT-14S | YPT-60 | YPT-60 | YET300 YF-1 | YET300 YF-1 |
| | | | YHT-8S | | YHT-14S | | YPT-60 | |

L11, L21 (R0, S0), MC1

| Capacity [kW] | 3.7 to 37.0 |
|--|-------------|
| Wire size (AWG)/ temperature rating Note 1 | #14/60°C |
| | #14/75°C |
| Crimp terminal | V2-4 |
| Crimping tool | YNT-1614 |

Supplement

L1, L2, L3

| Capacity [kW] | 3.7 | 5.5 | 7.5 | 11.0 | 15.0 | 18.5 |
|---|----------|----------|---------|---------|---------|-----------------|
| Wire size (AWG)/ temperature rating Note 1 | #11/60°C | #11/60°C | #9/75°C | #5/60°C | #3/60°C | #2/60°C |
| | #14/75°C | #11/75°C | | #5/75°C | #5/75°C | #3/75°C |
| Crimp terminal | 3.5-R4 | 3.5-R4 | 5.5-S4 | R14-5 | 22-S6 | L330T 459-23 |
| | R2-4 | | | | R14-5 | 22-S6 |
| Crimping tool | YHT-2210 | | | YHT-14S | YPT-60 | YPT-60 |
| | | | | | YHT-14S | YPT-60 |

| Capacity [kW] | 22.0 | 26.0 | 30.0 | 37.0 |
|---|---------|----------------|------------|-----------------|
| Wire size (AWG)/ temperature rating Note 1 | #1/60°C | #1/0//60°C | #2/0//60°C | 1/0/75°C |
| | #2/75°C | #1/75°C | #1/75°C | |
| Crimp terminal | 38-S8 | L330T 459-12 | | L330T 459-12 |
| | | 38-S8 | | |
| Crimping tool | YPT-60 | YET300 YF-1 | | YET300 YF-1 |
| | | YPT-60 | | |

8.2 Servo drive unit

| Type | | 1-axis (V1, V14) | | | | 2-axis (V2, V24) | |
|-------------------|--|------------------|----------|----------|------------|-------------------|-----------------------|
| Capacity [kW] | | 0.1 to 3.5 | 4.5 | 7.0, 9.0 | 11.0, 15.0 | 0.1+2 to 2.0+2 | 3.5+1.0 to 4.5+3.5 |
| Terminal block | P, N (L+, L-) | M6 | M6 | M6 | M6 | M6 | M6 |
| | Screw tightening torque [lb in/N·m] | 44.3/5.0 | 44.3/5.0 | 44.3/5.0 | 44.3/5.0 | 44.3/5.0 | 44.3/5.0 |
| | L11, L21 (R0, S0) | M4 | M4 | M4 | M4 | M4 | M4 |
| | Screw tightening torque [lb in/N·m] | 17.4/2.0 | 17.4/2.0 | 17.4/2.0 | 17.4/2.0 | 17.4/2.0 | 17.4/2.0 |
| | U, V, W | M4 | M5 | M5 | M8 | M4 | M4 |
| | Screw tightening torque [lb in/N·m] | 14.6/1.6 | 28.6/3.2 | 28.6/3.2 | 117.2/13.2 | 14.6/1.6 | 14.6/1.6 |

P, N (L+, L-)

The wire size is determined according to the connected power supply unit (MDS-B-CVE Series).

Supplement

L11, L21 (R₀, S₀)

| | |
|--|-------------|
| Capacity [kW] | 0.1 to 15.0 |
| Wire size (AWG)/ temperature rating | #14/60°C |
| Note 1 | #14/75°C |
| Crimp terminal | V2-4 |
| Crimping tool | YNT-1614 |

U, V, W

| Capacity [kW] | 0.1, 0.3 | 0.5, 1.0 | 2.0 | 3.5, 4.5 | 7.0 | 9.0 | 11.0 | 15.0 | |
|--|----------|----------|----------------|------------------|----------------------------|--------------------|---------|---------|----------------|
| Wire size (AWG)/ temperature rating | #16/60°C | #14/60°C | #11/60°C | #9/60°C | #8/60°C | #8/60°C | #5/60°C | #2/60°C | |
| Note 1 | #16/75°C | #14/75°C | #14/75°C | #11/75°C | #9/75°C | #8/75°C | #5/75°C | #3/75°C | |
| Crimp terminal | R1.25-4 | R2-4 | 3.5-R4 R2-4 | 5.5-S4 3.5-R4 | 5.5-S4 R5.5-5 3.5-R5 | R8-5 R5.5-5 | R8-5 | R14-8 | 38-S8 R22-8 |
| Crimping tool | YHT-2210 | | | | | YHT-8S YHT-2210 | YHT-8S | YHT-14S | YPT-60 |

8.3 Spindle drive unit

| Capacity [kW] | | 0.4 to 3.7 | 5.5 to 11.0 | 15.0, 18.5 | 22.0 to 30.0 | 37.0 |
|-------------------|---|------------|-------------|------------|--------------|------------|
| Terminal block | P, N (L+, L-) | M6 | M6 | M6 | M6 | M10 |
| | Screw tightening torque [lb in/N·m] | 44.3/5.0 | 44.3/5.0 | 44.3/5.0 | 44.3/5.0 | 234.3/26.5 |
| | L11, L21 (R ₀ , S ₀) | M4 | M4 | M4 | M4 | M4 |
| | Screw tightening torque [lb in/N·m] | 17.4/2.0 | 17.4/2.0 | 17.4/2.0 | 17.4/2.0 | 17.4/2.0 |
| | U, V, W | M4 | M5 | M5 | M8 | M8 |
| | Screw tightening torque [lb in/N·m] | 14.6/1.6 | 28.6/3.2 | 28.6/3.2 | 117.2/13.2 | 88.5/10.0 |

P, N (L+, L-)

The wire size is determined according to the connected power supply unit (MDS-B-CVE Series).

Supplement

L11, L21 (R₀, S₀)

| | |
|--|-------------|
| Capacity [kW] | 0.4 to 37.0 |
| Wire size (AWG)/ temperature rating | #14/60°C |
| Note 1 | #14/75°C |
| Crimp terminal | V2-4 |
| Crimping tool | YNT-1614 |

U, V, W

| Capacity [kW] | 0.4, 0.75 | 1.5 to 3.7, 5.5 | | 7.5 | 11.0 | 15.0 | 18.5 | 22.0 | 26.0 | 30.0 | 37.0 |
|--|--------------|-----------------|--------|--------------|-------------|-------------|-------------|-------------|-------------|-----------------|----------------|
| Wire size (AWG)/ temperature rating | #14/ 60°C | #11/60°C | | #9/ 60°C | #8/ 60°C | #5/ 60°C | #3/ 60°C | #2/ 60°C | #1/ 60°C | #2/0/ 60°C | #1/0/ 75°C |
| Note 1 | #14/ 75°C | #14/75°C | | #11/ 75°C | #9/ 75°C | #5/ 75°C | #5/ 75°C | #3/ 75°C | #2/ 75°C | #1/ 75°C | |
| Crimp terminal | R2-4 | 3.5-R4 | 3.5-R5 | R5.5-5 | R8-5 | R14-5 | 22-S6 | 38-S8 | 38-S8 | L330T 459-12 | R60-8 |
| | | R2-4 | R2-5 | 3.5-R5 | R5.5-5 | | R14-5 | R22-8 | | 38-S8 | |
| Crimping tool | YHT-2210 | | | | YHT-8S | YHT-14S | YPT-60 | YPT-60 | YPT-60 | YET300 YF-1 | YET300 YF-1 |
| | | | | | YHT-2210 | | YHT-14S | | | YPT-60 | |

Note 1: 60°C: 600V vinyl insulated wire (IV wire)
 75°C: 600V heat-resistant vinyl insulated wire/600V polyethylene insulated wire/(HIV wire)
 The conductors must be copper.

9. Spindle drive unit and motor combination

The combinations of the standard spindle drive unit and motor are shown below.

| Drive unit | Applicable motor output (kW) | |
|----------------------|--|-----------------------------|
| | SJ-() Series SJ-V/VL Series Note: 1 | SJ-N Series SJ-NL Series |
| MDS-B-SP/SPH/SPX-04 | | 0.2 |
| MDS-B-SP/SPH/SPX-075 | | 0.75 |
| MDS-B-SP/SPH/SPX-15 | | 1.5 |
| MDS-B-SP/SPH/SPX-22 | 2.2 | 2.2 |
| MDS-B-SP/SPH/SPX-37 | 3.7 | 3.7 |
| MDS-B-SP/SPH/SPX-55 | 5.5 | 5.5 |
| MDS-B-SP/SPH/SPX-75 | 5.5 7.5 | 7.5 |
| MDS-B-SP/SPH/SPX-110 | 5.5 7.5 11 | 11 |
| MDS-B-SP/SPH/SPX-150 | 7.5 11 15 | |
| MDS-B-SP/SPH/SPX-185 | 11 15 18.5 | |
| MDS-B-SP/SPH/SPX-220 | 11 15 18.5 22 | |
| MDS-B-SP/SPH/SPX-260 | 11 15 18.5 22 26 | |
| MDS-B-SP/SPH/SPX-300 | 15 18.5 22 26 30 | |
| MDS-B-SP/SPH/SPX-370 | 15 18.5 22 26 30 37 | |

Note 1: The applicable drive unit will differ according to the motor's rated output range and characteristics.
Contact Mitsubishi for details on the combinations.

II. MDS-B-CVE

1. Introduction

The MDS-B-CVE Series is the upward series of the MDS-B-CV Series. The specifications are the same as the MDS-B-CV Series except for the following matters.

- The depth of the MDS-B-CVE is smaller than the MDS-B-CV. (Upper compatible)
- The position of the connectors CN4, CN9, CN23 and the grounding terminal have been changed.
- Alarms #65 and 6B have been eliminated.

2. Outline

(1) Models

| Type MDS-B- | Capacity (kW) | Weight (kg) | Dimensions (H*W*D mm) | Appearance type |
|----------------|------------------|----------------|--------------------------|-----------------|
| CVE-37 | 3.7 | 3.5 | 380*60*200 | A1 |
| CVE-55 | 5.5 | 4.0 | 380*60*200 | |
| CVE-75 | 7.5 | 4.0 | 380*60*200 | |
| CVE-110 | 11 | 6.0 | 380*90*285 | B1 |
| CVE-150 | 15 | 7.0 | 380*120*285 | C1 |
| CVE-185 | 18.5 | 7.0 | 380*120*285 | |
| CVE-220 | 22 | 9.0 | 380*150*300 | D1 |
| CVE-260 | 26 | 9.0 | 380*150*300 | |
| CVE-300 | 30 | 9.5 | 380*150*300 | |
| CVE-370 | 37 | 9.5 | 380*150*300 | |

(2) Dimensions

| Appearance type H*W*D mm | A1 | B1 | C1 | D1 |
|-----------------------------|--|---|--|--|
| | <p>{Fin section } W:60 {:20}</p> <p>D:200</p> <p>H:380</p> | <p>{Fin section } W:90 {:105}</p> <p>D:285</p> <p>H:380</p> | <p>{Fin section } W:120 {:105}</p> <p>D:285</p> <p>H:380</p> | <p>{Fin section } W:150 {:105}</p> <p>D:300</p> <p>H:380</p> |

CAUTION

When carrying the unit, do not hold the plastic case section as the unit could drop. Securely hold the aluminum fin section with both hands. Take care to the edges of the fins when holding the section.

Supplement

(3) Details of appearance and dimensions.

Note 1: The positions of the CN4 and CN9 for the MDS-B-CVE-37 to 185 have been moved 39mm below the positions for the MDS-B-CV Series.

Note 2: The grounding Ⓧ has been changed from the terminal block to the screw on the unit installation base.

B-CVE-37
-55
-75

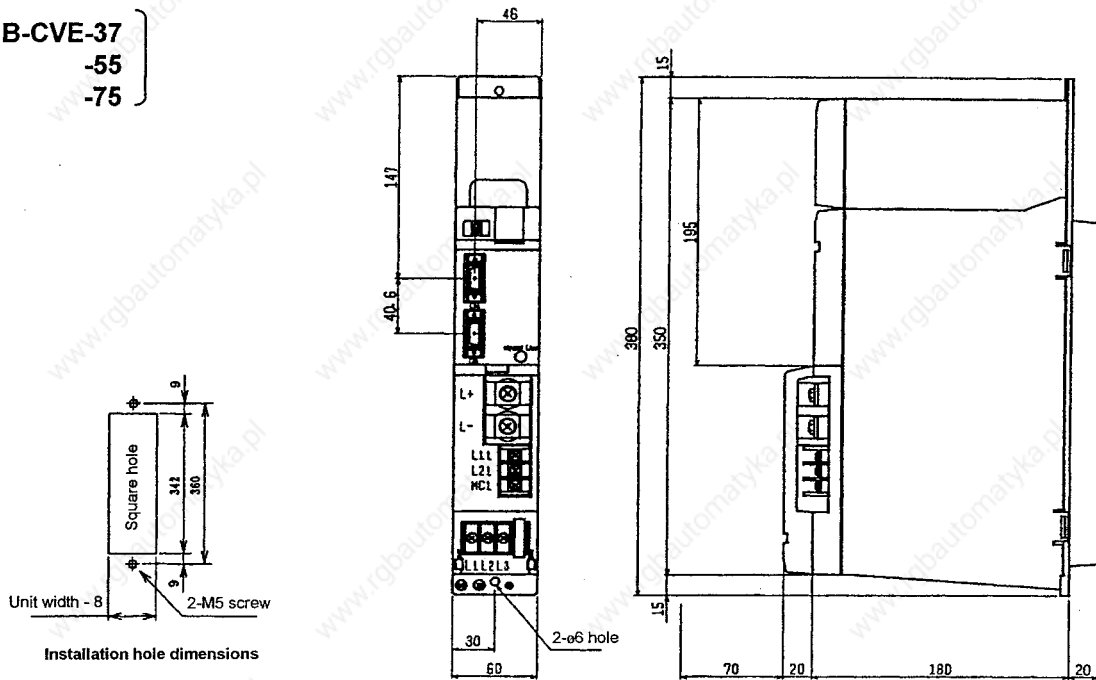

B-CVE-110

B-CVE-150
-185

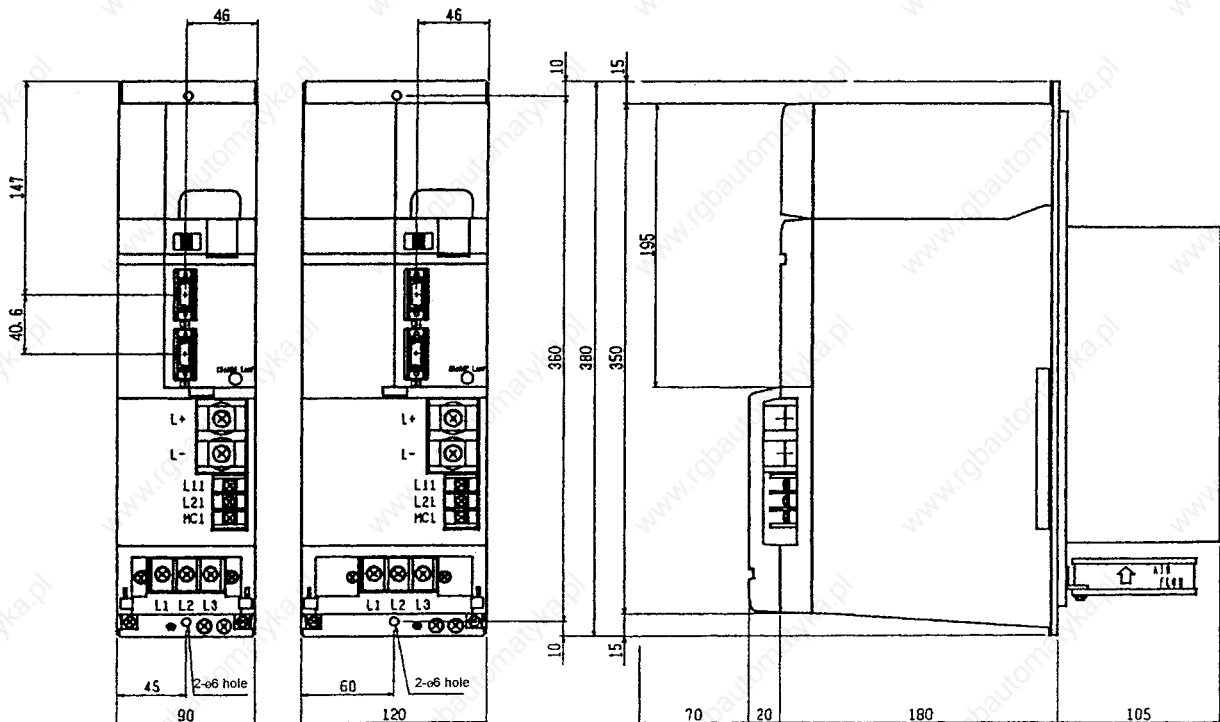

Supplement

B-CVE-220
-270
-300
-370

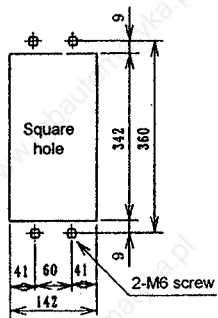
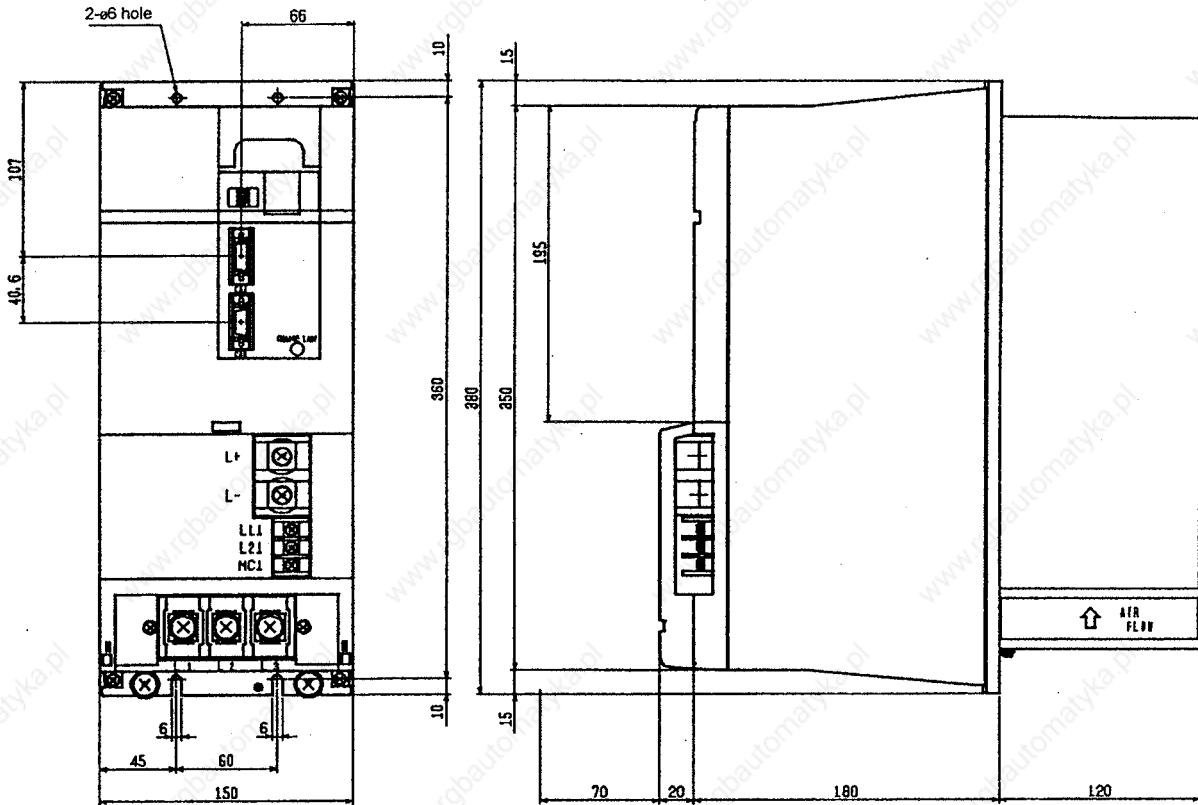

Installation hole dimensions

 **mitsubishi electric corporation**
HEAD OFFICE : MITSUBISHI DENKI BLDG., 2-2-3, MARUNOUCHI, CHIYODA-KU, TOKYO 100-8310, JAPAN

| | |
|------------|-----------------|
| MODEL | MDS-A/B Series |
| MODEL CODE | 003—298 |
| Manual No. | BNP-B3759B(ENG) |

Specifications subject to change without notice.

Printed in Japan on recycled paper.