

SNAP Power Supplies

Always use a separate field supply

Use a separate power supply for the field side of the I/O. Using the rack supply for field actuation and monitoring defeats the isolation the I/O module offers and therefore increases the chance of a ground loop within the control system. Additionally, a sudden change of current on the field side can cause undesirable voltage fluctuations that may interfere with the controller or I/O unit's operation.

Power wiring guidelines

- Use one power supply per I/O unit.
- Use one power supply per controller.
- Use 14 AWG wire.
- SNAP power supplies have short wires to minimize voltage drop. Do not extend the length of the wires.
- If you power multiple I/O units or controllers from one power supply, use a star wiring topology. Do not daisy-chain power wiring from one device to the next.

Installation

Panel Mounting (standard)

Mount the SNAP power supply in a location where the attached red and black power wires will reach the "+" and "-" power terminals on the SNAP mounting rack or controller. Do not extend the wires.

DIN-Rail Mounting (optional)

1. For DIN-rail mounting, remove the four screws that fasten the panel mounting base plate to the power supply. **Keep screws in a safe place.**
2. Remove panel mounting base plate.
3. In place of the panel mounting base plate, use the four screws removed in step 1 to fasten the DIN-rail adapter (purchased separately) to the power supply.
4. Mount the SNAP power supply on the DIN rail (next to the power connector on the I/O unit).

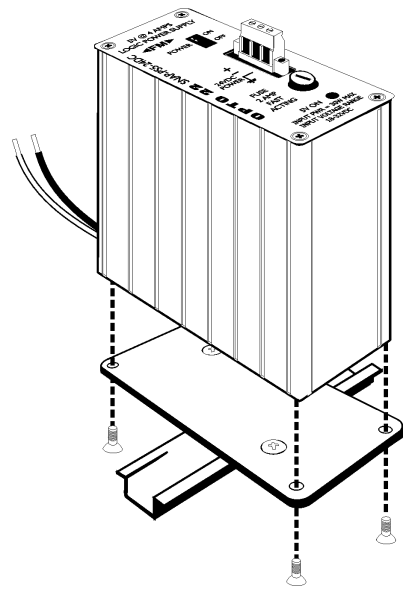
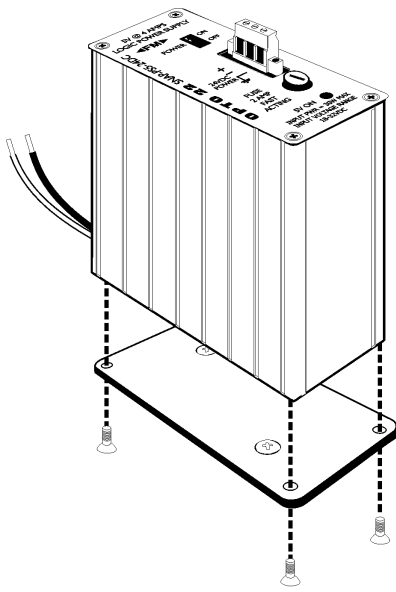
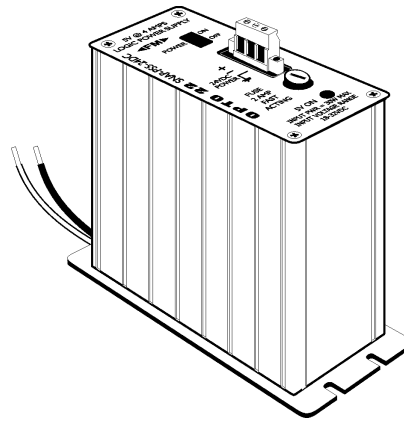

Wiring—Primary Power Supply

Wiring to a Standalone Controller

1. For a controller, check the controller's specifications in its data sheet or user's guide to make sure you have the correct power supply for the controller's requirements.
2. Follow directions in the controller's user's guide to wire the power supply to the controller. The power supply's red (or white-and-red) wire is the positive wire; the black (or white-and-black) wire is the negative wire.

Wiring to a SNAP I/O Unit

1. Using the power terminals on the SNAP mounting rack, attach the red wire to the "+" terminal and the black wire to the "-" terminal.

2. **For the SNAP-PS5 (not illustrated):** Using the removable input power connector on top of the power supply, apply 120 volts AC power between the two terminals marked "AC." The ground terminal should be connected to ground.
3. **For the SNAP-PS5-24DC (not illustrated):** Using the removable input power connector on top of the power supply, apply 24 volts DC power between the two terminals marked "±DC." The ground terminal should be connected to ground.
4. **For the SNAP-PS5U (illustrated below):** Using the removable input power connector on top of the power supply, apply 100–250 volts AC power between the two terminals marked "AC." The ground terminal should be connected to ground.

