

■ **Block Diagram**

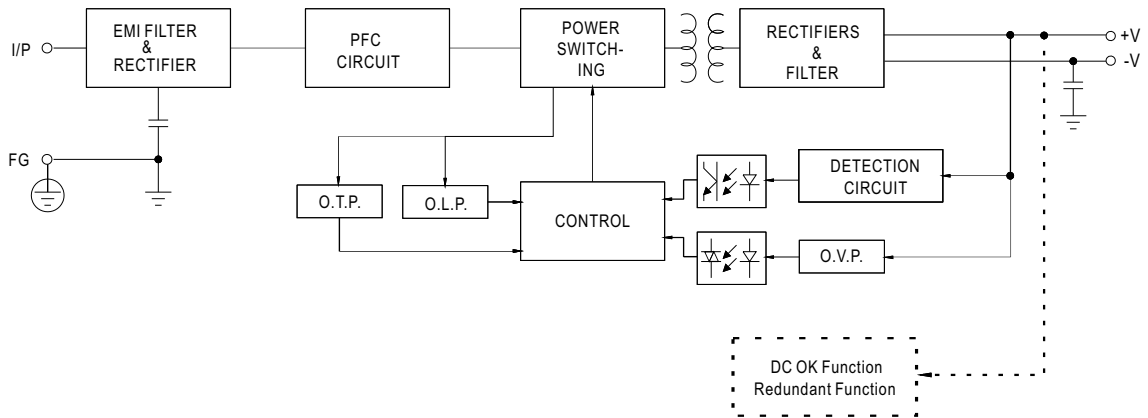

■ **Derating Curve**

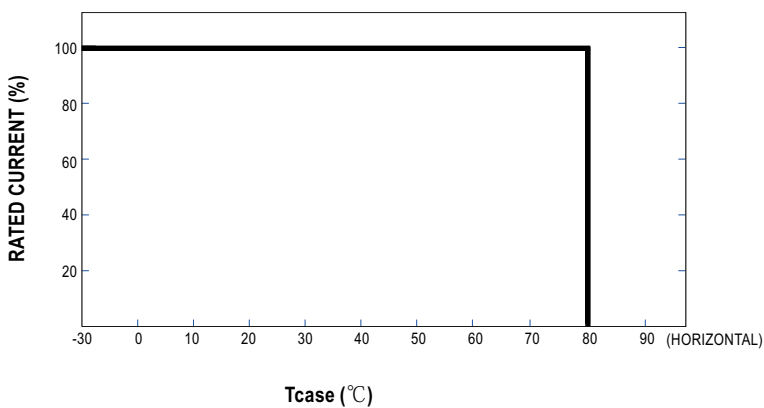
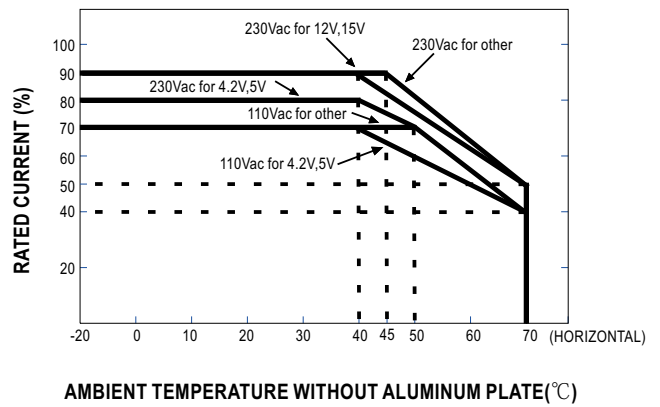
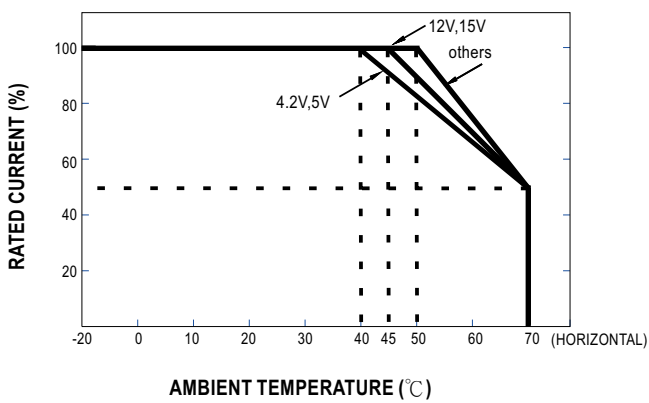

**■ STATIC CHARACTERISTIC**

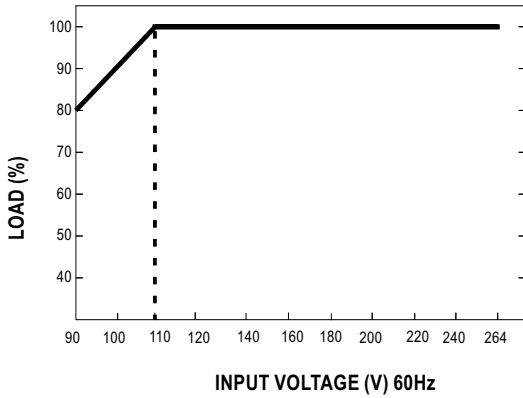

**■ DC OK Relay Contact**

Contact Close	PSU turns on/DC ok
Contact Open	PSU turns off/DC fail
Contact Rating(max.)	30Vdc/1A resistive load

**■ Redundant function**

- (1) UHP-500R is built-in redundant function and can be connected 2 units in parallel .
- (2) When in parallel operation the maximum load should not be greater than the rated power of any PSU.

