

### 40 Watts

- 40 W Convection Rating
- 1.5" by 3" Footprint
- Low 1.1" Profile
- High Efficiency
- Medical and ITE Approvals
- Class I & Class II Installations
- High Power Density
- Less than 0.15 W No Load Input Power
- 3 Year Warranty

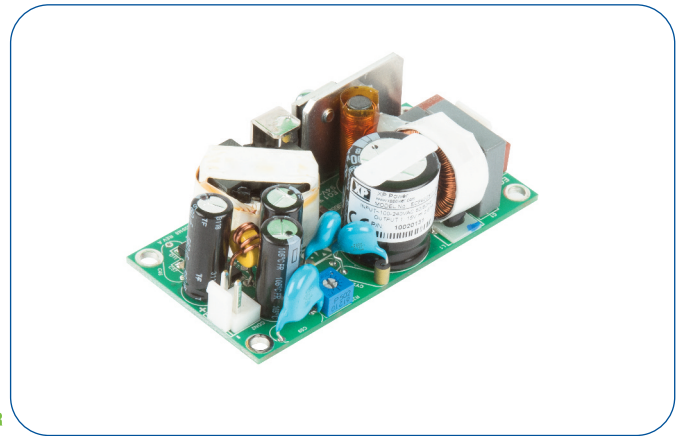

The ECF40 series is designed to minimize the no load power consumption and maximize efficiency to facilitate equipment design to meet the latest environmental legislation. Approved for medical and ITE applications in either Class I or Class II installations, this range of single output AC-DC power supplies are packaged in a low profile 1.1" height with a foot print of just 1.5" by 3". The ECF40 provides up to 40W convection-cooled over the full 90-264 VAC input range, and operates down to 80 VAC with minimal de-rating. The power supply features two AC line fuses and low leakage currents required by medical applications. The low profile, low noise and safety approvals covering ITE and medical standards allows the versatile ECF40 series to be used in a wide range of applications.

#### Dimensions:

##### ECF40:

3.00 x 1.50 x 1.10" (76.2 x 38.1 x 28.0 mm)

### Models & Ratings

Output Power	Output Voltage	Output Current	Efficiency <sup>(1)</sup>	Model Number
40 W	12.0V	3.34 A	91%	ECF40US12
40 W	15.0V	2.67 A	92%	ECF40US15
40 W	18.0V	2.23 A	93%	ECF40US18
40 W	24.0V	1.67 A	91%	ECF40US24
40 W	36.0V	1.11 A	90%	ECF40US36
40 W	48.0V	0.83 A	90%	ECF40US48

### Notes

1. Typical efficiency measured at full load and 230 VAC input.

### Mechanical Details

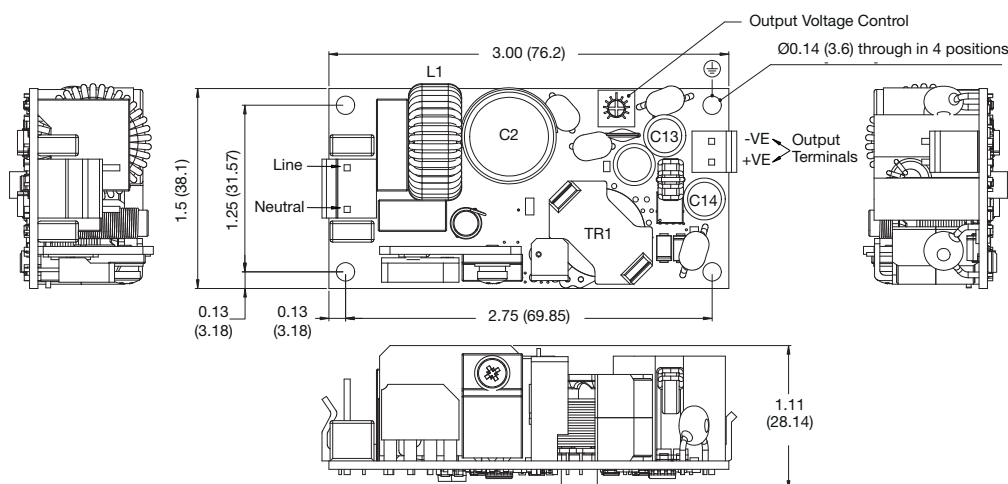

#### CN1 - Input Connector

Pin 1	Neutral
Pin 2	Not Fitted
Pin 3	Line

Mates with JST housing VHR-3N and JST Series SVH-21T-P1.1 crimp terminals

Mounting hole marked with ⊕ must be connected to safety earth for class I applications

#### CN2 - Output Connector

Pin 1	-Vout
Pin 2	+Vout

Mates with JST housing VHR-2N and JST Series SVH-21T-P1.1 crimp terminals

### Notes

1. All dimensions shown in inches (mm).  
Tolerance: ±0.02 (0.5)

2. Weight: 0.15 lbs (69 g) approx.

### Summary

Characteristic	Minimum	Typical	Maximum	Units	Notes & Conditions
Input Range	80	115/230	264	VAC	Derate output from 100% at 90 VAC to 90% at 85 VAC and 80% at 80 VAC
No Load Input Power			0.15	W	
Efficiency		90		%	230 VAC (see fig.1 & 2)
Operating Temperature	-25		+70	°C	See derating curve (fig.3)
Safety Approvals	ITE	IEC62368-1, IEC60950-1, UL 62368-1 2nd Ed., CSA C22.2 No. 62368-1-14, EN62368-1			
	Medical	IEC60601-1 Ed 3.1 Including Risk Management, ANSI/AAMI ES60601-1 & CSA C22.2 No.6061-1:08, EN60601-1			

### Input

Characteristic	Minimum	Typical	Maximum	Units	Notes & Conditions
Input Voltage - Operating	80	115/230	264	VAC	Derate output from 100% at 90 VAC to 90% at 85 VAC and 80% at 80 VAC
Input Frequency	47	50/60	63	Hz	Agency approval, 47-63 Hz
Power Factor					EN61000-3-2 class A
Input Current - Full Load		0.8/0.4		A	115/230 VAC
Inrush Current			70	A	264 VAC cold start, 25 °C
Earth Leakage Current			250	µA	264 VAC/60 Hz
No load Input Power			0.15	W	
Input Protection	T3.15 A/250 A, 250 V Internal fuse fitted in line and neutral.				

### Output - Main Output

Characteristic	Minimum	Typical	Maximum	Units	Notes & Conditions
Output Voltage	12		48	VDC	See Models and Ratings table
Initial Set Accuracy			±1	%	50% load, 115/230 VAC
Output Voltage Adjustment	10			%	
Minimum Load	0			A	No minimum load required
Start Up Delay		1	2	s	
Output Rise Time		50		ms	
Hold Up Time	8.3/20			ms	Min at full load 115/230 VAC
Line Regulation			±0.5	%	90-264 VAC
Load Regulation			1	%	0-100% load.
Transient Response			4	%	Recovery within 1% in less than 500 µs for a 50-75% and 75-50% load step
Over/Undershoot			5	%	Full load
Ripple & Noise			3/2	% pk-pk	12V/15-48V models
Overvoltage Protection	115		140	%	Vnom, recycle input to reset
Overload Protection	110		160	% I nom	
Short Circuit Protection					Continuous trip and restart (hiccup)
Temperature Coefficient			0.05	%/°C	

### General

Characteristic	Minimum	Typical	Maximum	Units	Notes & Conditions
Efficiency		90		%	Average active mode efficiency at 25%, 50%, 75% and 100% load
Isolation: Input to Output Input to Ground Output to Ground	4000			VAC	2 MOPP
	1500			VAC	1 MOPP
	500			VAC	1 MOPP at output voltage
Power Density			8.1	W/in <sup>3</sup>	
Mean Time Between Failure	500			kHrs	MIL-HDBK-217F, Notice 2 +25 °C GB
Weight		0.15 (69.0)		lb(g)	