

Models & Ratings

Output Voltage	Output Current ⁽¹⁾	Regulation		Ripple	Frequency	Model Number
		Load	Line			
0 to +100V	10mA	<0.1%	<0.1%	<0.75%	200-250kHz	C01
0 to +200V	5mA	<0.1%	<0.1%	<0.05%	250-350kHz	C02
0 to -200V	5mA	<0.1%	<1.0%	<0.05%	75-150kHz	C02N
0 to +300V	3.3mA	<0.1%	<0.1%	<0.03%	200-300kHz	C03
0 to +500V	2mA	<0.07%	<0.1%	<0.004%	250-350kHz	C05
0 to -500V	2mA	<0.5%	<0.5%	<0.005%	200-350kHz	C05N
0 to +600V	1.67mA	<0.1%	<0.1%	<0.003%	250-300kHz	C06
0 to -600V	1.67mA	<0.75%	<0.75%	<0.003%	125-300kHz	C06N
0 to +1000V	1mA	<0.3%	<0.3%	<0.005%	200-250kHz	C10
0 to -1000V	1mA	<0.5%	<0.3%	<0.002%	100-125kHz	C10N
0 to +1250V	1mA	<0.1%	<0.1%	<0.004%	200-250kHz	C12
0 to -1250V	1mA	<0.175%	<0.1%	<0.003%	100-125kHz	C12N
0 to +1500V	0.67mA	<0.1%	<0.1%	<0.002%	100-125kHz	C15
0 to -1500V	0.67mA	<0.2%	<0.2%	<0.002%	75-100kHz	C15N
0 to +2000V	0.5mA	<0.15%	<0.1%	<0.002%	75-100kHz	C20
0 to -2000V	0.5mA	<0.15%	<0.1%	<0.002%	75-100kHz	C20N
0 to +2500V	0.4mA	<0.03%	<0.2%	<0.1%	125-150kHz	C25
0 to -2500V	0.4mA	<0.5%	<0.2%	<0.2%	125-150kHz	C25N
0 to +3000V	0.33mA	<0.03%	<0.05%	<0.1%	75-100kHz	C30
0 to -3000V	0.33mA	<0.03%	<0.075%	<0.2%	75-100kHz	C30N
0 to +4000V	0.25mA	<0.25%	<0.2%	<0.1%	50-125kHz	C40
0 to -4000V	0.25mA	<0.2%	<0.1%	<0.1%	75-150kHz	C40N
0 to +5000V	0.2mA	<0.35%	<0.1%	<0.1%	75-150kHz	C50
0 to -5000V	0.2mA	<0.25%	<0.1%	<0.1%	125-175kHz	C50N
0 to +6000V	0.167mA	<0.25%	<0.1%	<0.1%	125-175kHz	C60
0 to -6000V	0.167mA	<0.25%	<0.15%	<0.1%	125-175kHz	C60N
0 to +8000V	0.125mA	<0.75%	<0.15%	<0.2%	100-150kHz	C80
0 to -8000V	0.125mA	<0.75%	<0.25%	<0.2%	100-150kHz	C80N

Mechanical Details

C01-C20

Top View

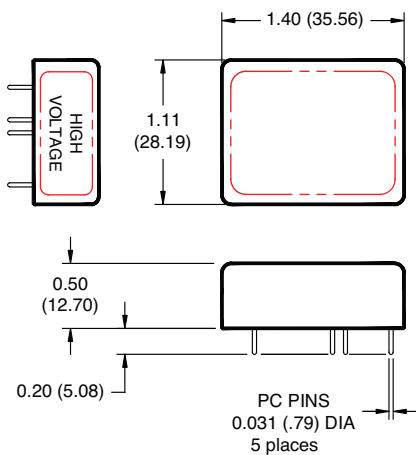

Bottom View

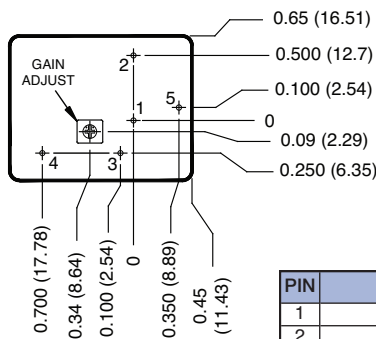

PIN	FUNCTION
1	(+) Input
2	Ground
3	Programming Voltage
4	HV Out
5	Case Ground

PCB Layout

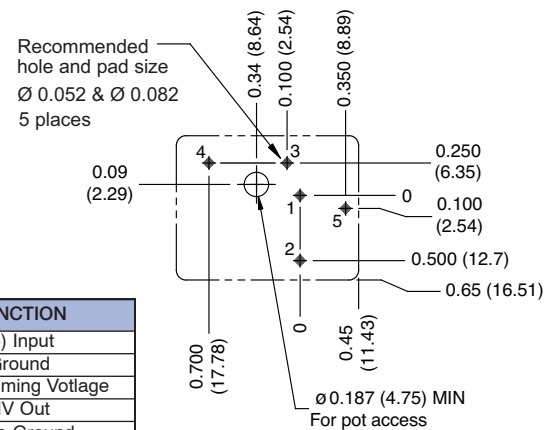

All dimensions are in inches (mm)
 Tolerance: X.XX ±0.02 (0.51)
 Pin Tolerance: ±0.005 (0.127)
 Weight: C01-C20: 1.1oz (31g)

All grounds internally connected except case. Case ground (Pin5) must be connected to ground, with no more than 50V between case ground (Pin 5) and circuit ground (Pin 2).

Mechanical Details

C25-C40

Top View

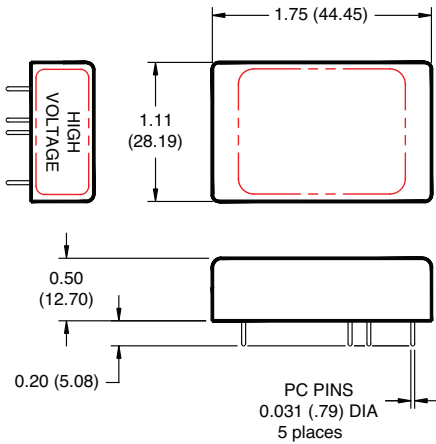

Bottom View

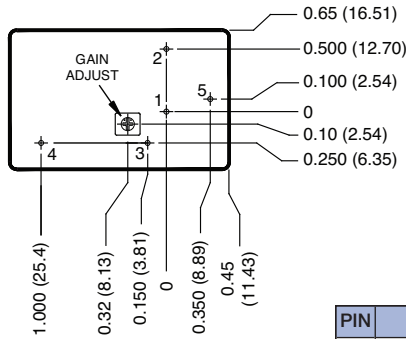

PCB Layout

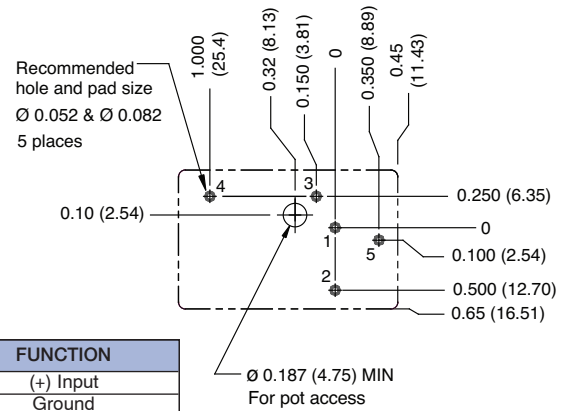

PIN	FUNCTION
1	(+) Input
2	Ground
3	Programming Votlage
4	HV Out
5	Case Ground

C50-C60

Top View

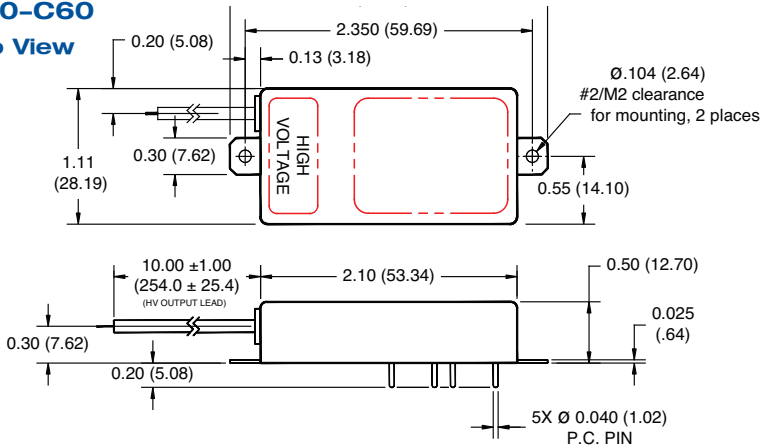

PCB Layout

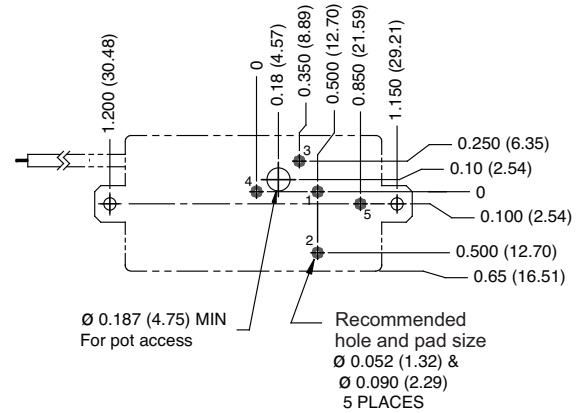

Bottom View

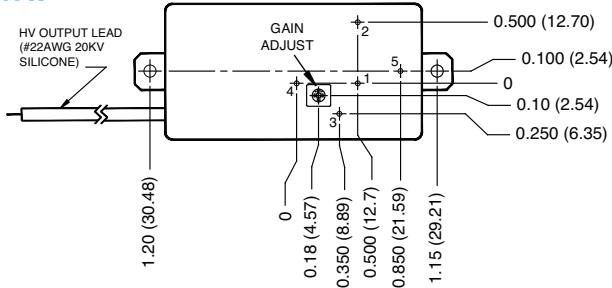

PIN	FUNCTION
1	(+) Input
2	Ground
3	Programming Votlage
4	HV Return
5	Case Ground
LEAD	HV Out

All dimensions are in inches (mm)
 Tolerance: X.XX ±0.02 (0.51)
 Pin Tolerance: ±0.005 (0.127)
 Weight: C25-C40: 1.3oz (36.8g)
 C50-C60: 1.8oz (51g)

All grounds internally connected except case. Case ground (Pin5) must be connected to ground, with no more than 50V between case ground (Pin 5) and circuit ground (Pin 2).