

2AD AC Motor

Project Planning

DOK-MOTOR*-2AD*****-PRJ2-EN-P

Title 2AD AC Motors

Type of documentation Project Planning

Document number DOK-MOTOR*-2AD*****-PRJ2-EN-P

Replaces 209-0042-4122-02

The purpose of this documentation

This documentation

- introduces 2AD motors,
- supplies explanatory technical information about the structural features of main spindle motors,
- assists in selecting the main spindle motor relevant to your needs and applications, and,
- outlines the technical data pertaining to 2AD motors.

Editing sequence

Document designation of previous editions	Release date	Comments
209-0042-4122-00	07.94	1st edition
209-0042-4122-01	07.95	1st reprint
DOK-MOTOR*-2AD*****-PRJ2-EN-P	11.97	2nd reprint

Copyright © INDRAMAT GmbH, 1997

Copying this document, and giving it to others and the use or communication of the contents thereof without express authority are forbidden. Offenders are liable for the payment of damages. All rights are reserved in the event of the grant of a patent or the registration of a utility model or design (DIN 34-1).

Published by INDRAMAT GmbH • Bgm.-Dr.-Nebel-Str. 2 • D-97816 Lohr a. Main
Telefon 09352/40-0 • Tx 689421 • FAX 09352/40-4885
Abt. ENA (MR)

Validity All rights are reserved with respect to the content of this documentation and the availability of the product.

Contents

Page

1. Introducing 2AD AC Motors	7
2. Technical information	10
2.1. Ambient conditions	10
2.2. Mechanical features	12
2.3. Electrical features	18
2.4. Mechanical accessories	20
2.5. Mounting Gearboxes	20
3. Technical data - 2AD 100	21
3.1 Nominal data	21
3.2. Holding brake	23
3.3 Motor blower	23
3.4. Dimensional data	24
3.5. Type codes	27
4. Technical data - 2AD 101	29
4.1 Nominal data	29
4.2. Holding brake	31
4.3. Motor blower	31
4.4 Dimensional data	32
4.5 Type codes	33
5. Technical data 2AD104	35
5.1 Nominal data	35
5.2. Holding brake	37
5.3 Motor blower	37
5.4 Dimensional data	38
5.5 Type codes	41

	Page
6. Technical data - 2AD 132	43
6.1 Nominal data	43
6.2 Holding brake	45
6.3 Motor blower	45
6.4 Dimensional data	46
6.5 Type codes	50
7. Technical data 2AD134	51
7.1 Nominal data	51
7.2 Holding brake	53
7.3 Motor blower	53
7.4 Dimensional data	54
7.5 Type codes	57
8. Technical data 2AD160	59
8.1 Nominal data	59
8.2 Holding brake	61
8.3 Motor blower	61
8.4 Dimensional data	62
8.5 Type codes	66
9. Technical data 2AD164	67
9.1 Nominal data	67
9.2 Holding brake	69
9.3 Motor blower	69
9.4 Dimensions	70
9.5 Type codes	73

	Page
10. Technical data 2AD180	75
10.1 Nominal data	75
10.2 Holding brake	77
10.3 Motor blower	77
10.4 Dimensions	78
10.5 Type codes	82
11. Technical data 2AD200	83
11.1 Nominal data	83
11.2 Motor blower	85
11.3 Dimensions	86
11.4 Type codes	89
12. Technical data 2AD225	91
12.1 Nominal data	91
12.2 Motor blower	93
12.3 Dimensions	94
12.4 Type codes	96
13. Mechanical Accessories	97
13.1 Blower base	97
13.2 Labyrinth seal	99
14. Electrical connections	101
14.1 Motor power connections	101
14.2 Motor Power Cables	107
14.3 Motor blower connections	110
14.4 Motor feedback connection	114
14.5 Type Designations	117

	Page
15. State of Delivery	118
16. Identifying the merchandise	119
17. Storage and Transport	120
17.1 Notes on Packaging	120
17.2 Storage	120
18. Safety Guidelines for Electrical Drives	121
18.1 General Information	121
18.2 Guidelines on Protection Against Contact with Electrical Parts...	122
18.3 Instructions on „Safely-isolated extra low voltages“	123
18.4 Instructions on Protection While Handling and Mounting	123
18.5 Instructions on Protecting Against Dangerous Motions	123
19. Assembly and Installation	125
19.1 General Assembly Instructions	125
19.2 Mounting the Motor	125
19.3 Connecting the Motor	125
20. Servicing Guidelines	127
20.1 Maintenance	127
20.2 Contacting Customer Service	127
20.3 Repair Card	128
21. Index	129

1. Introducing 2AD AC Motors

Application AC motors of the 2AD series are used in:

- machine tools as main spindle drives and servo drives with high performance capabilities
- printing machines
- packaging machines
- reshaping machines

Power range In conjunction with drive controllers, these motors feature:

- a broad speed range, and,
- a broad speed range under field control of 1:6.

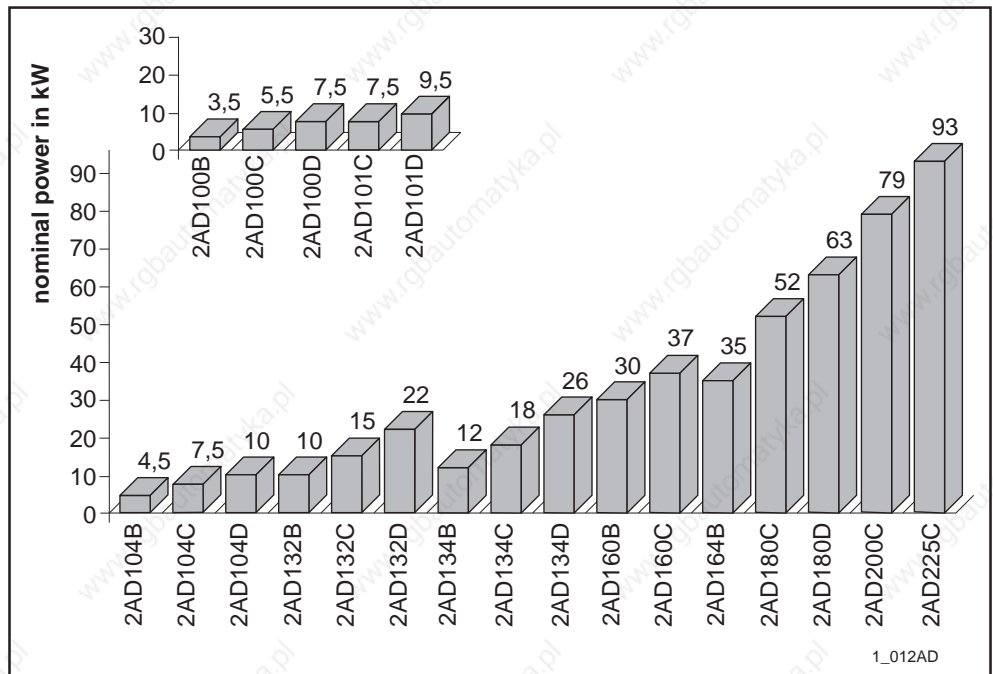

Fig. 1.1: Nominal power stages of 2AD motors

Motor feedback The motor feedback measures rotor position and signals it to the drive. This regulates speed and rotor position. It functions with a resolution of 1/2 000 000th revolution.

Holding brake The output shaft can be clamped into position at standstill using the holding brake. This means that the main spindle is safely held in place within the machine tool. Versions with either electrical clamp or electrical release capabilities are available.

Shaft extension A shaft extension makes it possible to attach an additional position encoder to the B side of the motor. This, however, requires the use of a radial blower.

Construction Either flange or foot installation is available to help meet the demands of the varying installation requirements and conditions.

No maintenance As the main spindle motor is an asynchronous motor, it requires no maintenance.

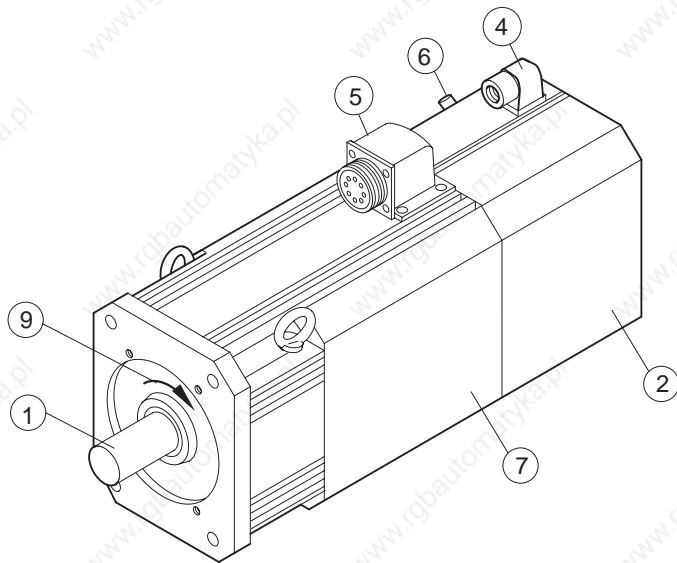

**2AD100, 101, 104
with axial blower**

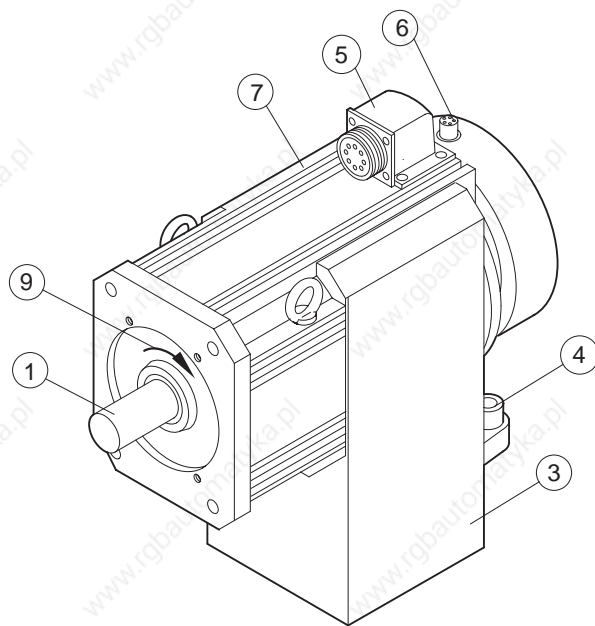

**2AD100, 104
with radial blower**

- ① Output shaft
- ② axial blower
- ③ radial blower
- ④ motor blower connection
- ⑤ power connection with integral connections for
 - thermal sensor
 - holding brake
- ⑥ Motor feedback connectin
- ⑦ Holding brake (integral)
- ⑧ side B shaft end
- ⑨ clockwise rotational direction

Output shaft



with key

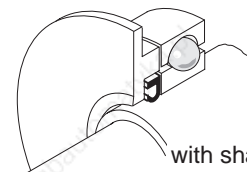

with shaft
sealing
ring

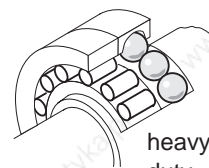

heavy-
duty

1_02A2AD

1. Introducing 2AD motors

Power connection

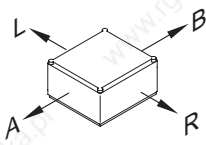

output direction can be selected

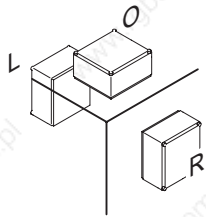

position can be selected

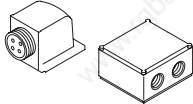

power connector/terminal box can be selected

Accessories

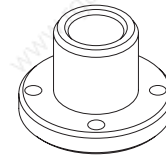
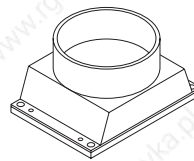

blower base

Accessories

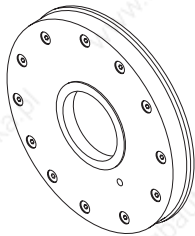

Labyrinth seal

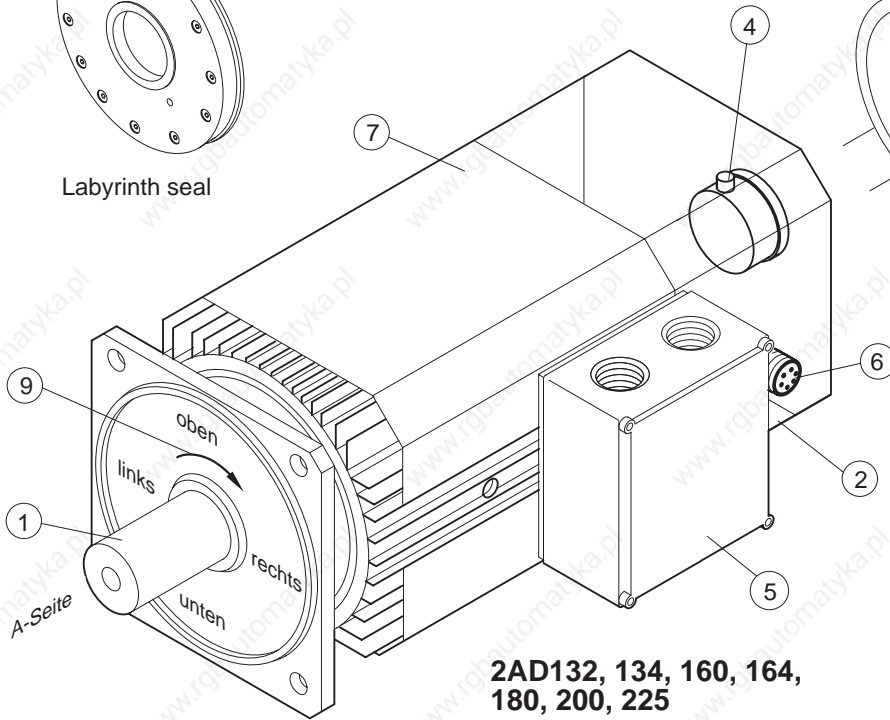

2AD132, 134, 160, 164, 180, 200, 225

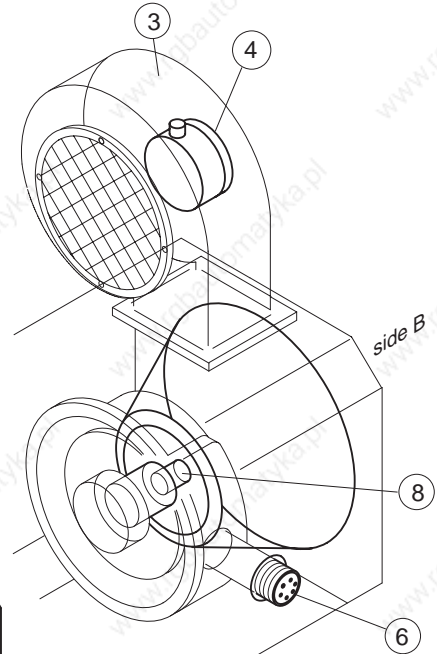

Holding brake

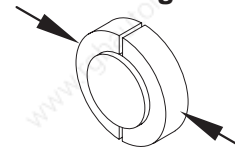

Construction

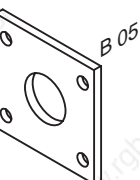
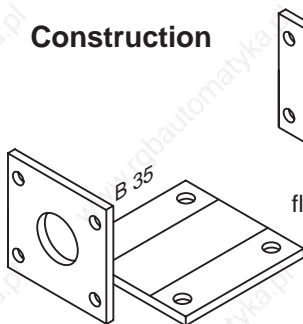

flange mounting

Flange or foot mounting

Vibration severity level

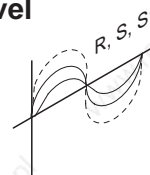

1_02B2AD

Fig. 1.2: 2AD motors - definition of terms

2. Technical information

2.1. Ambient conditions

*Installation altitude,
ambient temperature*

The ratings outlined in document: "AC main spindle drives with 2AD regulated main spindle motor - selection data, doc. no. 9-567-013-4" are achieved under the following conditions:

ambient temperature: from 0° to +45°C

installation altitude: up to 1,000 meters above sea level

The diagrams in Figure 2.1 depict the drop in power under other than above conditions. If deviating ambient temperatures and higher installation altitudes occur simultaneously, then multiply both power factors.

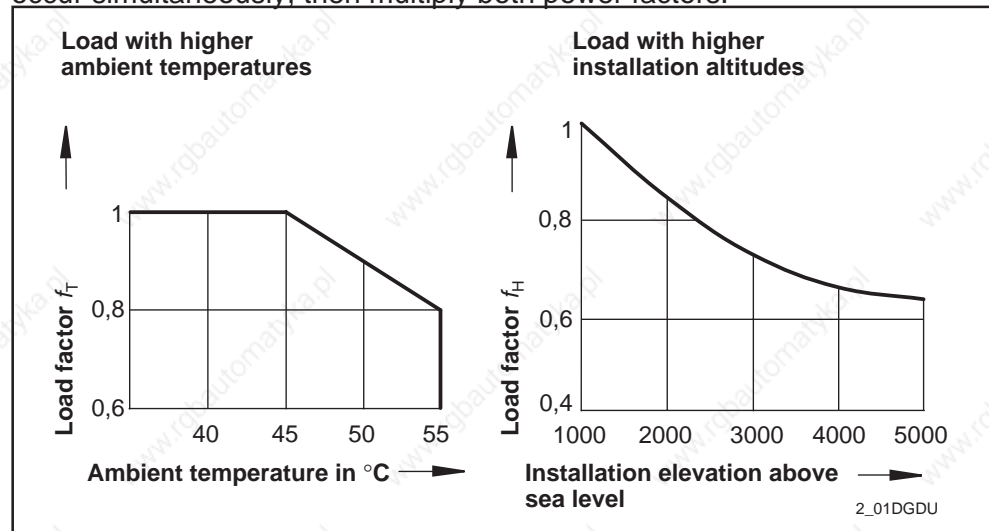

Fig. 2.1: Load capacities with higher ambient temperatures and installation altitudes

Type of protection

The main spindle motor with housing and cover are, per DIN 40050, protected against:

- contact with parts either moving or to which voltage is being applied, and,
- penetration by solid objects and water.

The category of protection is indicated by the abbreviation "IP" (International Protection), with two digits for the protection grade, e.g., IP 40.

The first digit denotes the protection grade for contact and penetration by foreign objects (see table in Figure 2.2).

The second digit denotes the protection grade for water (see table in Figure 2.3).

Figure 2.4 lists the range of protection categories for main spindle motors.

2. Technical information

1st digit	Protection category (protection against contact and foreign objects)
0	No protection
1	Protection against penetration by solid objects with a diameter greater than 50 mm. No protection against deliberate penetration, e.g., hands, but will keep larger body surfaces out.
2	Protection against penetration by solid objects with a diameter greater than 12 mm. Keeps out fingers and similar objects.
3	Protection against penetration by solid objects with a diameter greater than 2.5 mm. Keeps out tools, wires and similar objects with a thickness greater than 2.5 mm.
4	Protection against penetration by solid objects with a diameter greater than 1 mm. Keeps out tools, wires and similar objects with a thickness greater than 1 mm.
5	Protection against dust deposits. Penetration by dust is not completely prevented. Does not permit dust to penetrate to the extent that it influences the operation of the equipment (protection against dust). Total protection against penetration.
6	Protection against dust (dust-proof). Total protection.

Fig. 2.2: Categories of protection against contact and penetration by foreign objects

2nd digit	Protection grade (protection against water)
0	No protection
1	Protection against vertically dripping water. Does not permit any damaging affects (dripping water).
2	Protection against vertically dripping water. Does not permit any damaging affects to equipment (housing) tilted up to 15° in comparison to the normal position (water dripping at an angle).
3	Protection against water falling at an angle of up to 60°. Does not permit any damaging effects (spraying water).
4	Protection against water sprayed at the equipment (housing) from all directions. Does not permit any damaging affects (splashing water).
5	Protection against a jet of water sprayed from a nozzle onto the equipment (housing) and coming from all directions. Does not permit any damaging affects (jet of water).

Fig. 2.3: Categories of protection against penetration by water

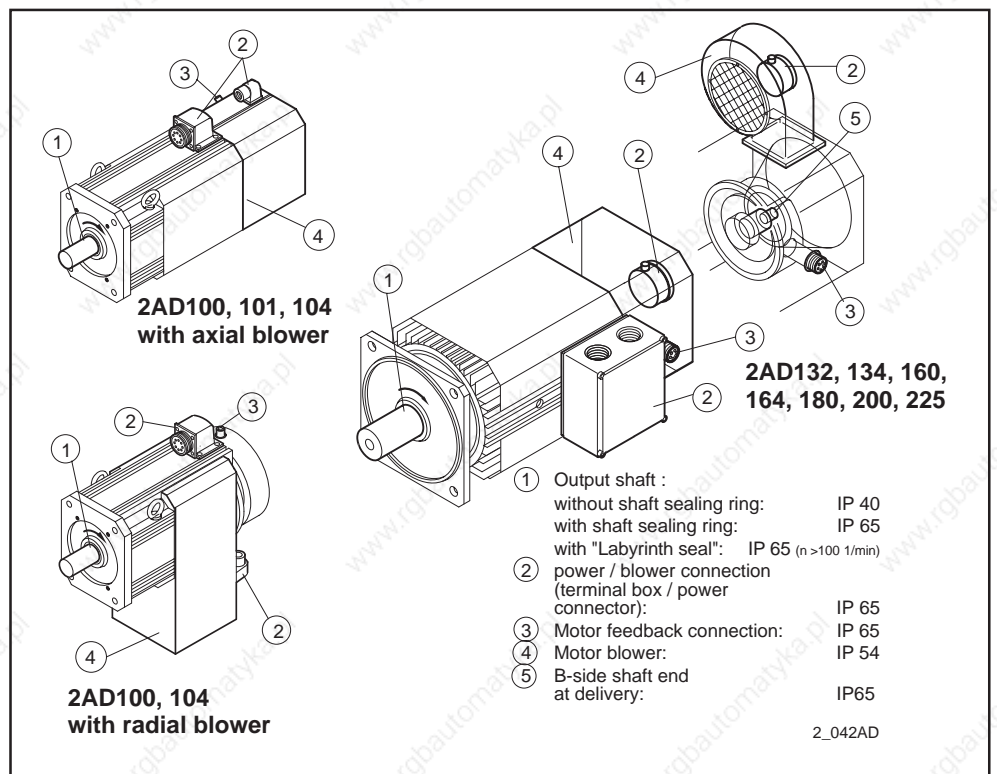

Fig. 2.4: Protection categories for the 2AD main spindle motors

2.2. Mechanical features

Type of construction,
installation position

2AD motors are available in versions

- B05 for flange mounting
- B35 for flange and foot mounting

Figure 2.5, "Permissible installation positions", depicts installation positions and outlines important guidelines.

Motor	allowable mounting positions per DIN IEC 34-7	Important mounting instructions
B05 B14	 <p>IM B 5 IM V 1 IM V 3</p>	<p>Vertical installation IMV1, IMV3 / IMV5, IMV6: Do not allow liquids (water, oil, coolant, etc.) to run into the motor along the output shaft. Even the use of a seal at the output shaft does not prevent liquids penetrating the motor. Prevent contamination by liquids penetrating the output shaft (side A shaft feed through) when attaching the motor.</p>
B35	 <p>IM B 35 IM B 6 IM B 7</p> <p>IM B 8 IM V 5 IM V 6</p> <p style="text-align: right;">2_052AD</p>	<p>Foot installation: Do not permit the following loads on the motor feet:</p> <ul style="list-style-type: none"> • Radial loads affecting the motor feet in the form of a tractive force. In this case, alter the installation position, or mount on the flange. • Transmission of loads occurring at the drive. If possible, mount the motor to the drive with a flange, or mount motor and drive separately.

Fig. 2.5: Permissible installation positions

Output shaft

Plain shaft:

For friction-locked shaft-hub connections.

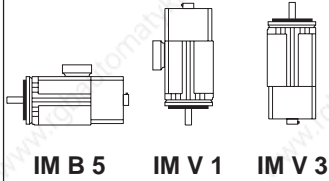
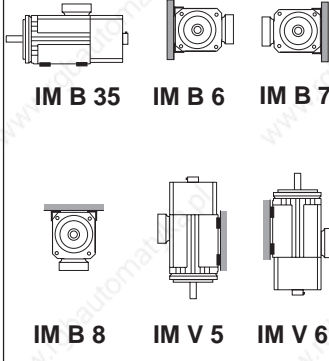
The higher run quality and the backlash-free connection between shaft and hub are a significant advantage of this recommended design.

Use tension sets, pressure sleeves or other such elements to couple in pinions, belt discs or similar drive elements.

Output shaft with key (as per DIN 6885 Blatt 1; Ed. 08/1968):

This connection is suited to take up torques which make low demands of the shaft-hub connection.



Shaft damage!

During a powerful reverse operation it is possible for the key to swing out. Ever-increasing deformations in this area can, in turn, cause the shaft to break.

The use of a plain shaft is recommended.

2. Technical information

This connection is suited to take up torques with a constant direction. The hub must be axially secured in this case. A tapped center hole with thread is on the small side.

Balanced with full key:

The rotor is balanced with the key used in the shaft-hub assembly. The **rotor** is balanced **with the full key**. A balanced, interconnecting part (toothed wheel etc.) must be used. The keyway in the hub is not dependent upon the length of the key.

Balancing with half a key:

There is half a key in the keyway in the shaft. The mass ratios occurring at the keyway are comparable to those of a plain shaft. If a full key is inserted, then the projecting section of the key creates a state of imbalance. The **rotor with the full key is not balanced**.

The interconnecting part must equalize the rotor's state of imbalance. The keyway in the hub should correspond to the length of the key. Use a stepped key for shorter keyways. The customer must modify the keyway.

Output shaft with seal

The motor is equipped with a sealing ring, per DIN 3760, type A, at the output shaft where it is attached to a drive which has an oil bath or circulating-oil lubrication.

The shaft seal is a rubbing seal. Wear and frictional heat occur at the lip of this seal. **Make sure the points of contact are sufficiently lubricated**. This ensures the least wear. The points of contact may not be permitted to ever run dry!

The lubricant is simultaneously a coolant. It dissipates the frictional heat occurring at the point of contact.

Please note the "Important installation guidelines" in Figure 2.5 and "Permissible installation orientations", on page 12, if the motor is vertically mounted.

Shaft loads

Radial shaft load:

The permissible radial force at the output shaft is dependent upon bearing assembly and average speed. The diagrams in the "Technical data" section outline the values for:

- standard bearing assemblies, and,
- heavy-duty assemblies.

The heavy-duty assembly can take greater radial loads. The cylindrical roller bearing on side A of the bearing assembly absorbs the radial forces. This assembly should only be used in exceptional cases as it doubles the rate of lubricant consumption.

Motors with heavy-duty bearing assemblies may only be operated with radial loads. Sliding friction could otherwise damage the bearings. See the "Technical data" section for minimum radial load values.

Axial shaft loads:

Only very low axial loads are acceptable (see "Technical data"). Thus, the motors are not suited for helical toothed output pinions.

Bearing service life

Mechanical service life:

Indramat main spindle motors are equipped with lifetime lubricated deep-groove ball and cylindrical roller bearings.

The mechanical service life of the bearings equals 20,000 working hours (bearing calculations as per DIN 662, section 1), if the radial loads and average speeds listed in section "Technical data" are maintained. Lubricant consumption also has a significant affect on bearing service life.

The duration of lubricant consumption is longer than the mechanical service life if the bearings have a normal load. Normal loads are:

- Radial loads:
corresponding to the "Permissible radial loads" diagrams in the "Technical data" section.
- Average speeds:
as outlined in the "lubricant consumption" diagram in the "Technical data" section, whereby, $n_m < n_{m(tf=20\,000\,h)}$
- Operating the motor within the permissible ambient temperature range of: 0° to +45°C.

Lubricant consumption:

Non-conforming loads cause the lubricant to be consumed in less than 20,000 working hours. This has an adverse affect on bearing service life.

Lubricant consumption is outlined in the "Lubricant consumption" diagram in the "Technical data" section.

If higher average speeds occur with a heavy-duty bearing assembly, the lubricant can be consumed more quickly. Thus, the working life of the motor is limited to that period in which the lubricant is available.

A longer working life for the motor can be anticipated if a standard bearing assembly is used as the time over which lubricant is available is doubled if the load remains constant. A higher than specified load on the standard bearing assembly reduces the mechanical service life to under 20,000 working hours.

If the working life of the motor is limited by increased lubricant consumption, then it is possible to increase the working life of the motor, in some cases, by using a standard bearing assembly instead of the heavy-duty one.

In this case, Indramat must re-calculate bearing service life. Please contact our Sales Office and inform them of your application requirements (load cycle, speeds, bearing loads, etc.).

The following flow chart in Figure 2.6, "Sequential determination of the bearing assembly", offers assistance in determining which bearing assembly to select.

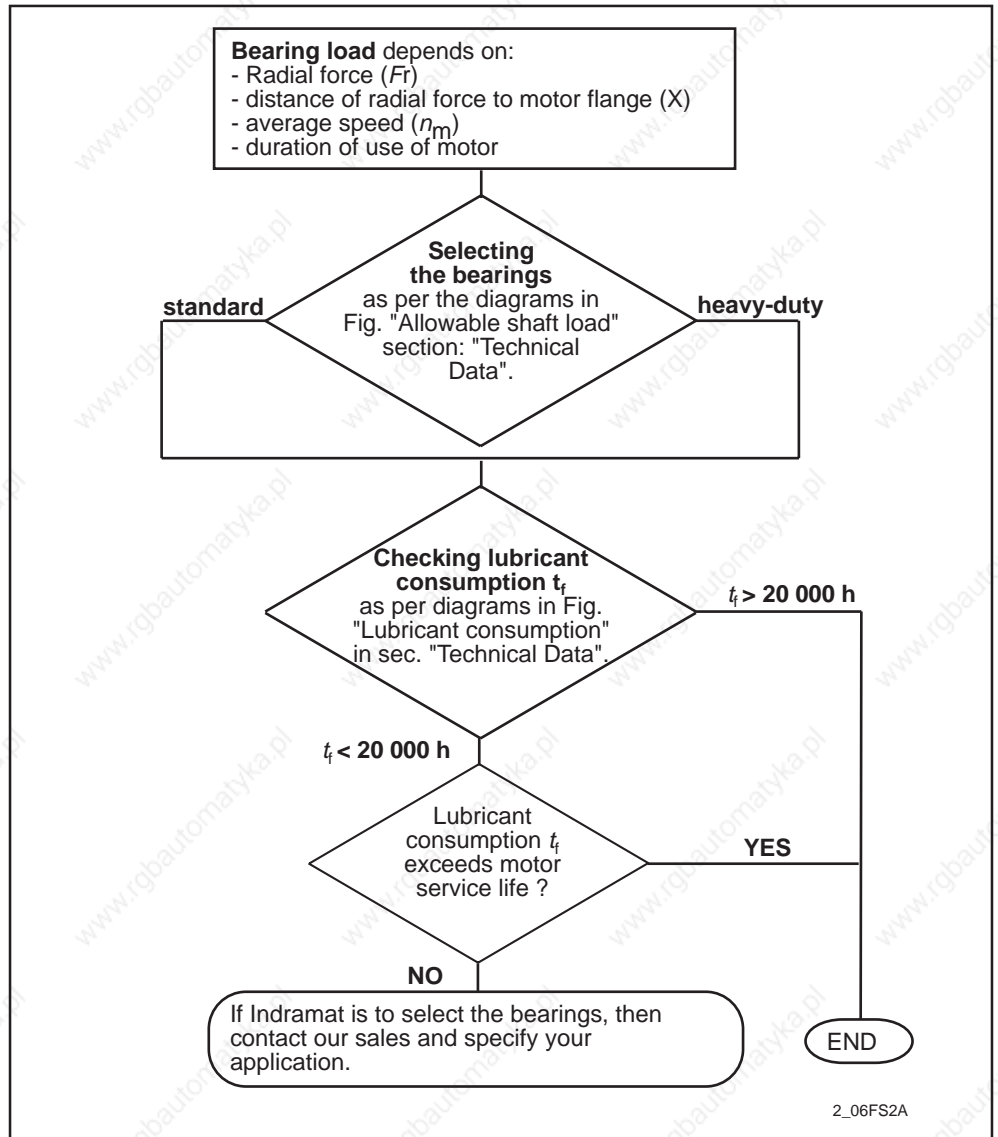

Fig. 2.6: The sequence for determining bearing assembly

Holding brake

The 2AD motor series is available with integral holding brakes which can be ordered with **electrically-engaged clamp** or **electrically-engaged release**.

Main spindle applications of the 2AD motors:

The **electrically-engaged holding brake** is a locking element of the main spindle when it is standing still or when the drive enable is switched off (for example, when exchanging tools without a closed position control loop).

There can be no clamping until the drive has signalled that the motor is at a standstill.

Do not use an electrically-released holding brake in main spindle applications. If the brake is unintentionally applied, in this case, (for example, as a result of a power failure or wire breakage), the brake could be destroyed at high speeds.

Servo-applications of the 2AD motors:

The **electrically-released holding brake** holds linear axes when at standstill and when the drive enable signal is not applied. With vertical axes, in particular, the drive enable should not be switched off until the brake has clamped the mechanical system once it is standing still! The occasional closing of the holding brake because of a power failure or in an E-stop situation is acceptable within the range of the braking energy permitted for the respective type of holding brake.

A heavy-duty electrically-released holding brake is also available.

The electrically-clamped holding brake should not be used in servo applications. There is no clamping of the axis when there is no power!

Do not use the holding brake as if it were a working brake. It may only close when the motor is standing still.

Shaft extension

A side-B shaft end is only needed if drives with DIAX01 controllers (KDA, TDA, RAC) require absolute actual rotor position values for track control. An absolute encoder is coupled in for this purpose on side B.

Actual rotor position values can more advantageously be directly relayed by the drive controllers to the controls. Controllers of the DIAX01 series (KDA, TDA, RAC) can tap off incremental actual position values while controllers of the DIAX03 series (DDS02.2, DKR) and those of the DIAX04 series (HDD, HDS) can tap off absolute actual position values from the motor feedback and relay this information to the controls. No encoder is needed for this purpose.

The 2AD motor is available, upon request, with a mounted absolute encoder (see "AC main spindle drives with regulated 2AD main spindle motors, doc. no. 9-567-013-4"). A notation on the order next to the absolute encoder is all that is required.

The B-side shaft extension is a plain shaft. The protection category at delivery is IP 65 for the motor with a B-side shaft extension without encoder. Encoders must also have protection category IP 65 because the feed through of the shaft extension is not sealed.

Due to lack of space, motors with a shaft extension may only have radial blowers at the B end.

Balance class

The main spindle motor is dynamically balanced as per balance class R (reduced) as per DIN ISO 2373.

Balance classes S (special) and S1 are also available, if special demands need to be made of the run quality. The table in Figure 2.7 outlines the root-mean square values of the vibrations.

2. Technical information

Vibrations V_{eff} in mm/s								
balance class	Motor size							
	100 to 132				160 to 225			
	speed in min^{-1}				speed in min^{-1}			
	600-1800	1800-3600	3600-6000	6000-8000	600-1800	1800-3600	3600-6000	6000-8000
R	0,71	1,12	1,8	2,8	1,8		2,8	4,5
S	0,45	0,71	1,12	1,8	0,71	1,12	1,8	2,8
S1	0,28	0,45	0,71	1,12	0,45	0,71	1,12	1,8

Fig. 2.7: Root-mean square vibrational values

Cooling method A 2AD motor is always equipped with a blower on side B. An air stream fed over the surface of the motor via air baffles is used for cooling. Two air stream directions are available for axial blowers:

- air stream from side B to side A of the motor (blowing)
- air stream from side A to side B of the motor (suction).

The air stream in a radial blower always blows from side B to side A of the motor. We strongly recommend the use of radial blowers in main spindle motors with a second shaft end.

There must be a sufficient supply of air for cooling once the motor is mounted. See the "Motor blower" section in the "Technical data" section for the average air requirements.

2.3. Electrical features

Terminal diagram Figure 2.8 is a schematic diagram. It is the checklist for all the electrical connections needed to operate the 2AD motor.

The following electrical connections are on the 2AD motor:

- power connection with the motor's NTC thermistor connection and holding brake connection
- motor feedback connection
- motor blower connection

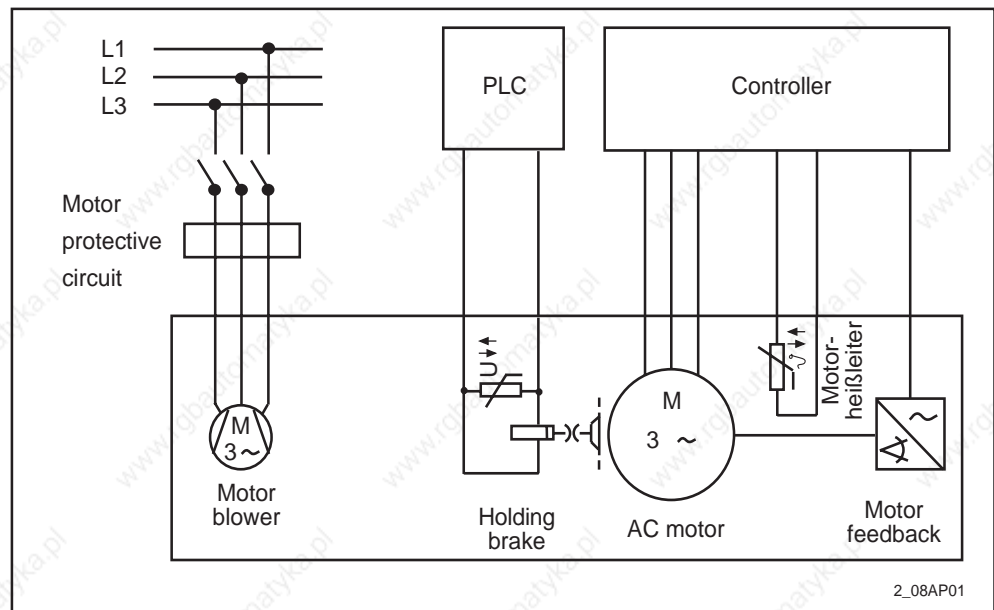

Fig. 2.8: Schematic main spindle motor diagram

Power terminal The power terminal in main spindle motors can be either

- a terminal box, or,
- a power connector.

Whether or not both options can be used depends on the motor size. This information is specified in the relevant type codes.

The position of the power connection is selected when ordered. It cannot be changed after delivery.

The position of the power terminal can be specified when the order is placed, but cannot be changed after delivery. The cable output direction out of the terminal box or power connector can be turned in increments of 90°. It can be changed after the motor is delivered.

Integrated into the power terminals are the connections for the:

- motor NTC thermistor and
- the holding brake.

2. Technical information

Motor NTC thermistor The motor NTC thermistor is built into the motor windings. The NTC thermistor monitor in the drive protects the motor against overheating. The drive sends out an error message if the motor is shutdown for thermal reasons. The connection is integrated into the power connection.

Holding brake The holding brake connection is integrated into the power terminal. The holding brake is triggered by the unit's control circuits (DDS02.2, DKR, HDS).

Motor feedback The motor feedback connection is on the same side of the motor as the power terminal. It is a flanged socket. The position of the motor feedback connection cannot be changed once the motor is delivered.

The motor feedback is available in three versions:

- high-resolution motor feedback (type "3") for use with KDA/TDA/RAC/DDS02.2/DKR/HDS
- Digital servo feedback (type "6") for use with DDS02.2/DKR/HDS
- Digital servo feedback with integral multiturn absolute encoder (type "7") for use with DDS02.2/DKR/HDS

Motor feedback	Absolute accuracy	Relative accuracy
high-resolution motor feedback (in 2AD and ADF: type 3)	$\pm 0.02^\circ$ ($\pm 1.2'$)	rel.: $\pm 0.01'$
digital servo feedback (in 2AD and ADF: types 6 and 7)	$\pm 0.009^\circ$ ($\pm 0.5'$)	rel.: $\pm 0.01'$

Fig. 2.9: Motor feedback accuracy

High-resolution motor feedback For relative indirect position detection. Replaces separate incremental encoder on the motor.

Digital servo feedback Digital servo feedback features: After a power failure or the initial POWER ON, the axis must be run to its point of reference before operation can begin.

Digital servo feedback with integral multiturn absolute encoder For absolute indirect position detection within 4096 motor revolutions. Replaces a separate absolute encoder on the motor.

The absolute axis position in this feedback option is retained even after the power is shut off.

Motor blower The type of motor blower connection corresponds to the selected power connection (up to 2AD 132: either power connector or terminal box). The motor blower is connected over its own protective circuit and thus works independently of the controller.

2.4 Mechanical accessories

Labyrinth seal (M02 2AD...)

Motors which must be protected against liquids penetrating the motor output shaft should be equipped with a labyrinth seal because it cannot wear down. The labyrinth seal is available as an accessory for motors 2AD132, 2AD160, 2AD180 and 2AD200. It is mounted before the motor is mounted.

The effectiveness of the labyrinth seal starts at 200 min^{-1} . This is why it should only be used in connection with the optional shaft sealing ring, which becomes effective at $0... 200 \text{ min}^{-1}$. Liquid levels must retain a minimum clearance to the motor shaft!

Blower support base (M01 2AD...)

If motors are to be operated in very dirty environments (dust, oil, vapors of various kinds), then it is possible to conduct clear air via a pipe or air channel for the motor cooler. To connect the air channel in motors 2AD132, 2AD160 and 2AD180 it is possible to obtain an additional blower support base.

The blower support base can only be mounted to the blower housing of radially cooled motors. This, of course, means that the motor must be equipped with such. To connect the air channel, replace the radial blower with the blower support base.

If the ventilating air is being brought from a short distance (up to about 1.5 m), from the roof or a side wall of the room in which the machine is installed, then the blower can be connected to the motor over an air channel! Any directional change in this path should not exceed 90° !

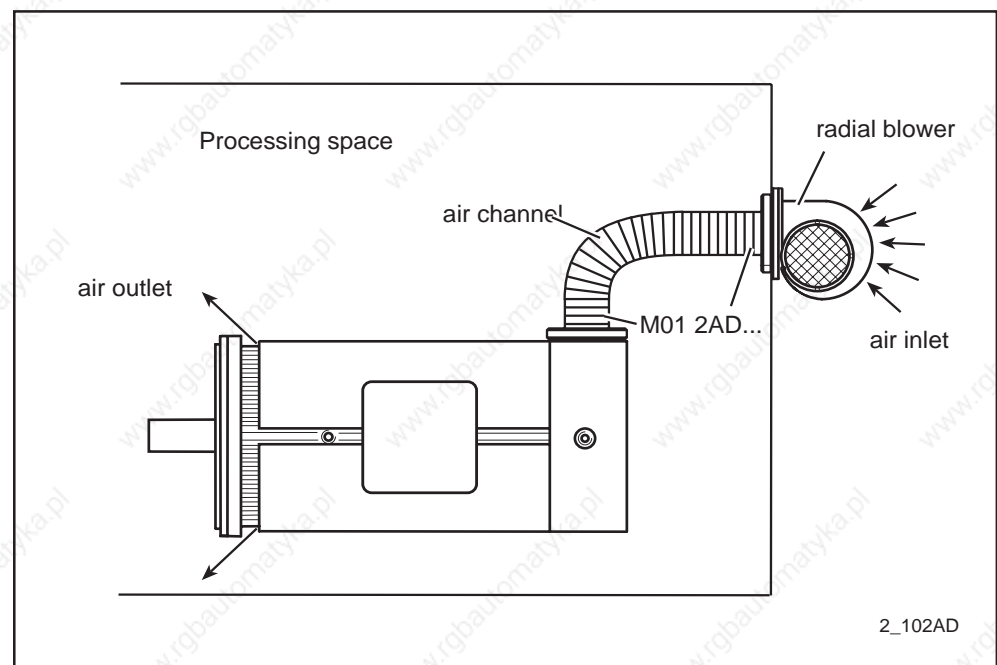

Fig. 2.10: Motor cooling via air channel - possible solution

2.5 Mounting Gearboxes

If the motor uses a coaxial planetary gearbox, then order the motor from Indramat with the gearbox already mounted!

3. Technical data - 2AD 100

3.1 Nominal data

Designation	Symbol	Unit	2AD100		
			B	C	D
Motor size			B	C	D
Windings designation			AS		
Nominal power ¹⁾	P_n	kW	3.5	5.5	7.5
Nominal torque ¹⁾	M_n	Nm	22	35	48
Base speed	n	min ⁻¹	1500		
Maximum speed	n_{max}	min ⁻¹	9000		
Nominal current	I_n	A _{eff}	17	27	35
Nominal voltage	U_n	V _{eff}	182	168	173
Rotor inertia ²⁾	J_M	kgm ²	0.014	0.021	0.028
Thermal time constant	t_{th}	min	35	40	45
Min. terminal cross-section EN 60204, section 1/ 2/86	A	mm ²	4		6
Average sound pressure level at 1 meter (PWM=4kHz)	L_p	dB(A)	70		
Mass ³⁾	m	kg	37	49	60
Ambient temperature		°C	0° to 45°		
Insulation classification DIN VDE 0530 section 1			F		
Balance class ⁴⁾ DIN ISO 2373)		R, S, S1		R, S
¹⁾ Values determined as per DIN VDE 0530, section 1 Characteristic operating curves are available for the listed nominal rates to help in the selection of the AC main spindle motor. These take operating modes S1, S2 and S6 into account. ²⁾ Values without holding brake. ³⁾ Values without holding brake, with blower. ⁴⁾ See Figure 2.7 "Vibrations in mm/s" for values.					

Fig. 3.1: Nominal data 2AD100

Permissible shaft load

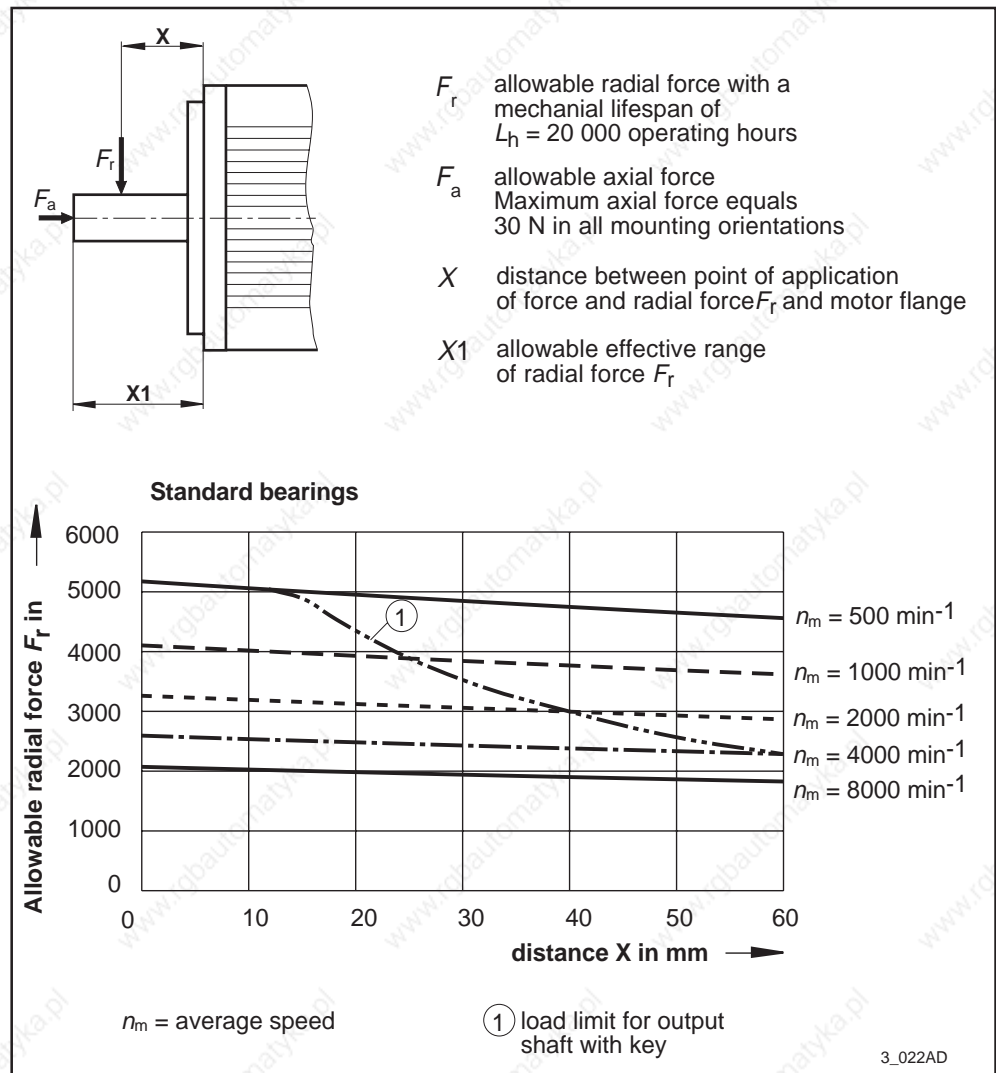

Fig. 3.2: Permissible shaft load 2AD100

Lubricant consumption

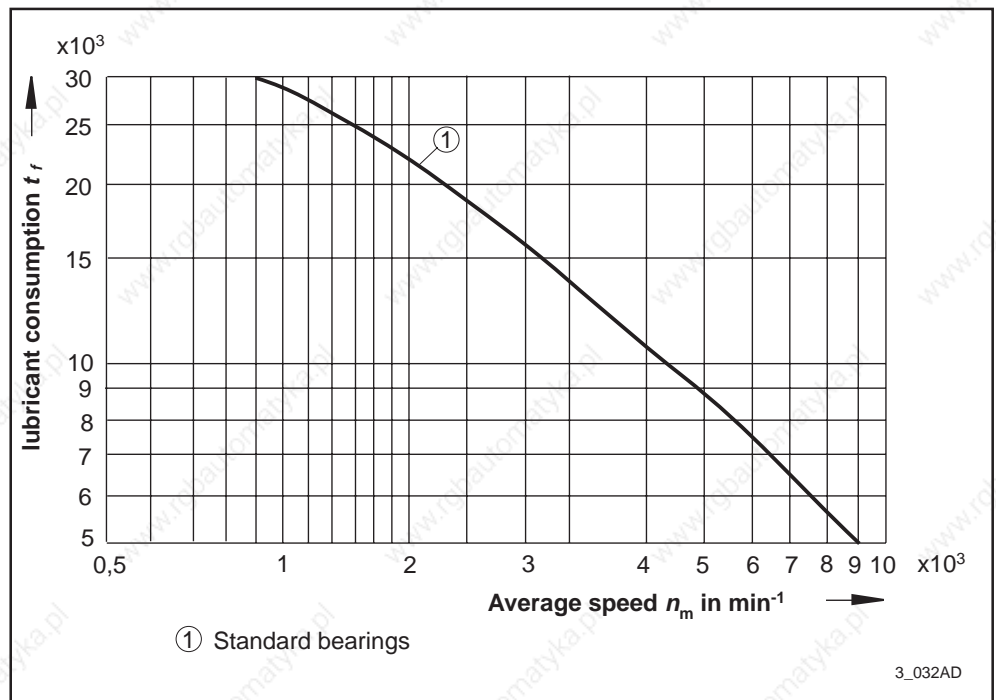

Fig. 3.3: Lubricant consumption duration 2AD100

3.2. Holding brake

Designation	Symbol	Unit	Version	
			electrically engaged	electrically released
Operating principle			electrically engaged	electrically released
Holding torque	M_h	Nm	30	24
Nominal terminal voltage	U_n	V	24 ± 10%	
Nominal current	I_n	A	0.9	
Moment of inertia	J_B	kgm ²	0.0007	
Maximum braking energy	W_{max}	Ws	20,000	
Maximum speed	n_{max}	min ⁻¹	9,000 ¹⁾	
Release delay	t_l	ms	50	100
Clamping delay	t_k	ms	50	60
Mass	m	kg	1,5	
<p>¹⁾ In the case of electrically-released holding brakes, the maximum speed is determined by the maximum braking energy, W_{max}, of the holding brake. It is calculated as follows:</p> $n_{max} = \sqrt{\frac{2 W_{max}}{J_M + J_B + J_C}} \cdot \frac{30}{3,14}$ <p> J_M rotor moment of inertia J_B holding brake moment of inertia J_L load moment of inertia, reduced (attachments to output shaft) </p>				

Fig. 3.4: Technical data of holding brake for 2AD100

3.3 Motor blower

Designation	Symbol	Unit	Version		
			axial blower		radial blower
Air current			B → A blowing recommended	A → B suction	B → A blowing
Power consumption	S_N	VA	60	70	60
Nominal voltage	U_N	V	230 or 115V, 50/60 Hz, ±10%		
Average air volume	V	m ³ /h	230		

Fig. 3.5: Technical data of motor blower for 2AD100

3.4. Dimensional data

Motor with axial blower and feedback types 3, B05, B35

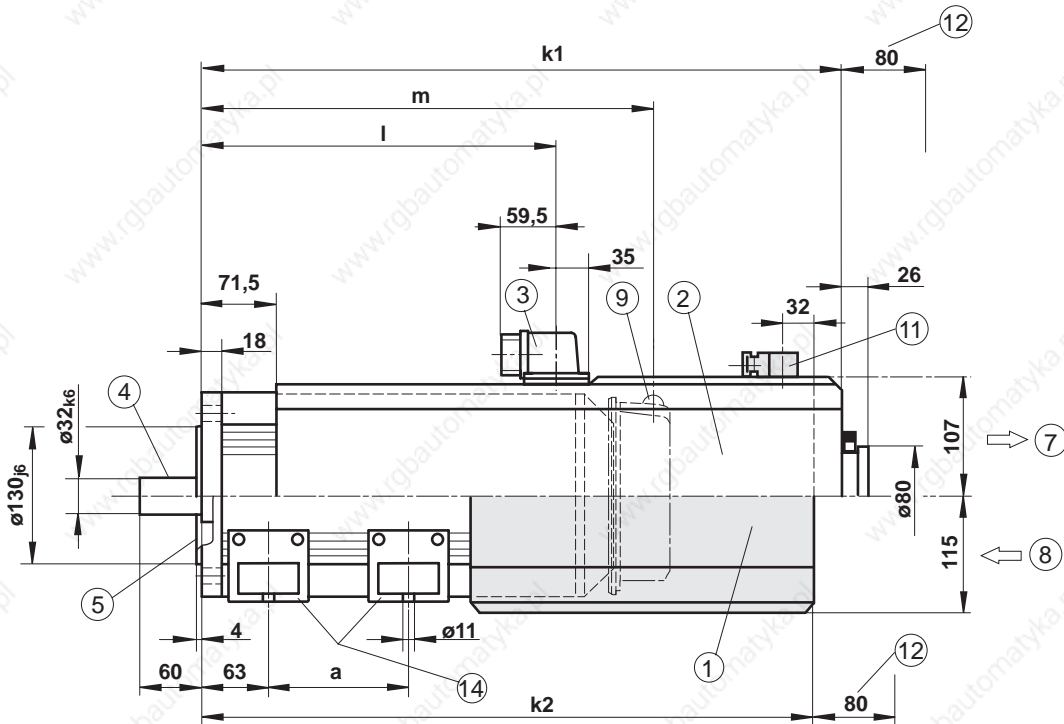

Motor with radial blower and feedback types 3, B05

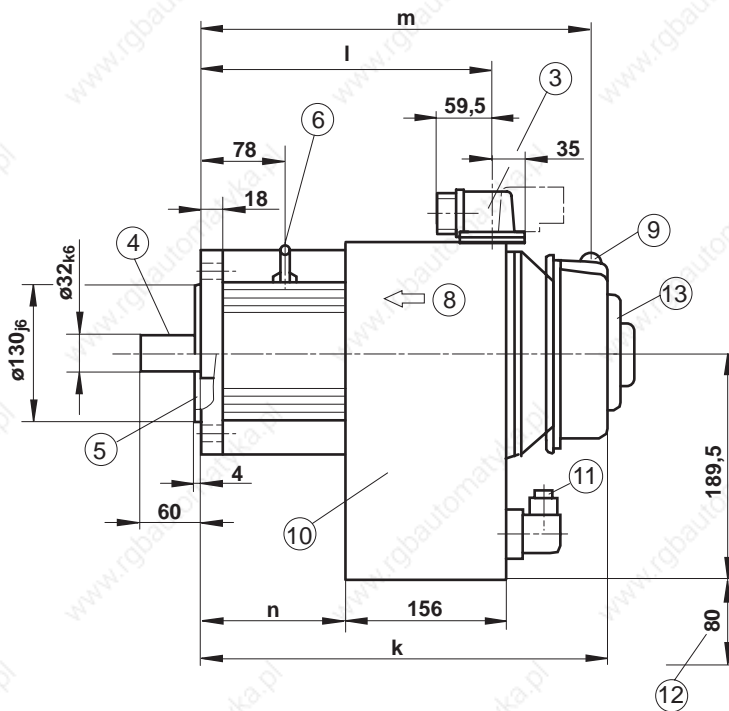

3_06100A

3. Technical data - 2AD 100

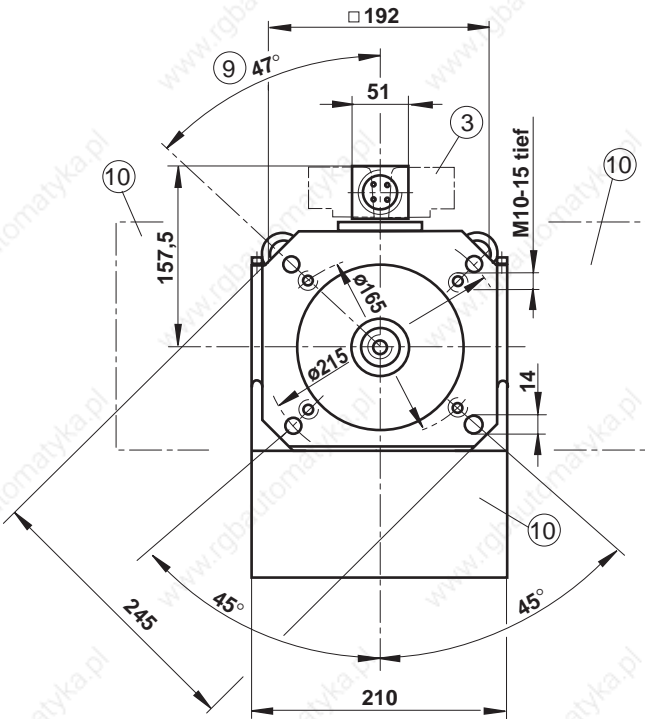
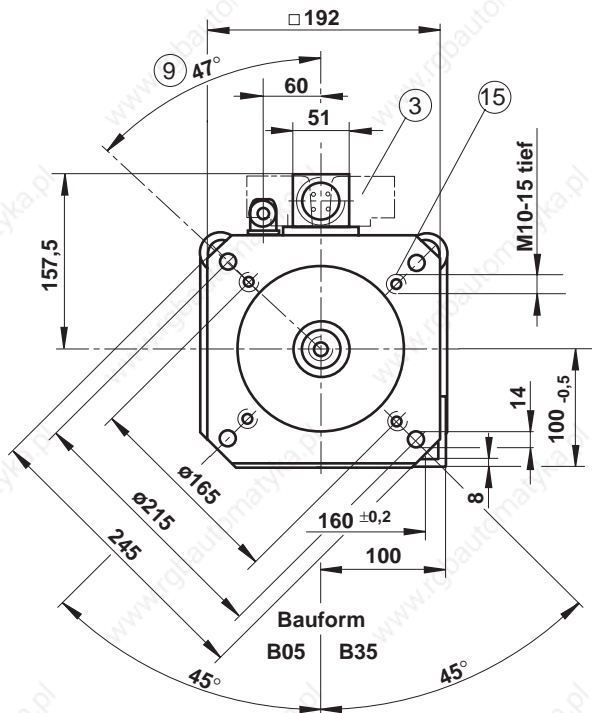

Dim.:	2AD100B	2AD100C	2AD100D
k1	538	613	688
k2	507	582	657
k	370	445	520
l	256	331	406
m	348,5	423,5	498,5
n	120	100	175
a	80	140	215

- ① Axial blower air stream B → A blowing
Blower connection: connector turnable by 90°
- ② Axial blower air flow A → B suction
Blower connection: terminal box with cable threaded joint.
- ③ Power connection
- ④ Plain shaft end tolerance
DIN 42955 - R
center drill hole on front
DIN 332 - DS M8x19
- ⑤ flange dimensions per
DIN 42948
- ⑥ ring screw M8 - DIN 580
- ⑦ air flow A → B
- ⑧ air flow B → A
- ⑨ Motor feedback connection type 3
(flange socket), arranged per position
of power connection
- ⑩ Radial blower;
position of radial blower may
not be the same as power connection
- ⑪ motor blower connection:
connector turnable by 90°
- ⑫ Mounting distance (minimum
for pulling in ventilating air)
- ⑬ B side shaft end, for dim.
see Fig. 3.8
- ⑭ B35 (Flange and foot mounting)
only with axial blower air flow B → A
- ⑮ thread holes for mounting type
B14 (Standard)

Tolerances:

Dim. to	6	30	120	400	1000	2000
Tolerance	±0,1	±0,2	±0,3	±0,5	±0,8	±1,2

3_06100B

For available version see Fig. 3.10 - type codes

Fig. 3.6: Dimensional data 2AD100

3. Technical data - 2AD 100

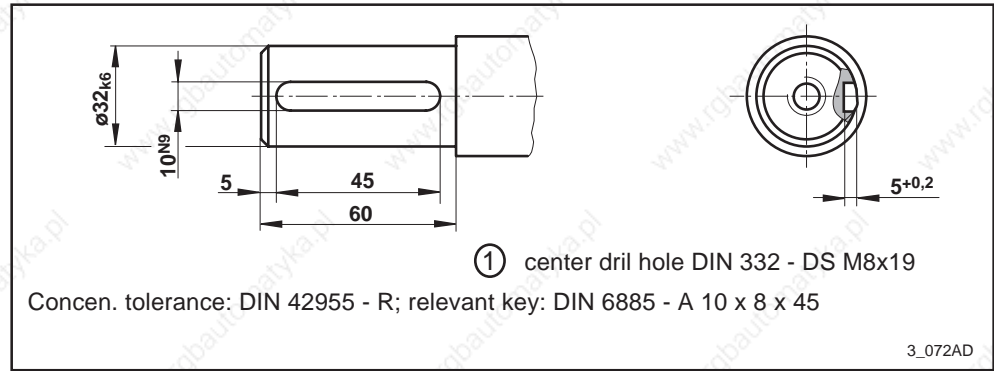

Fig. 3.7: Output shaft with key for 2AD100

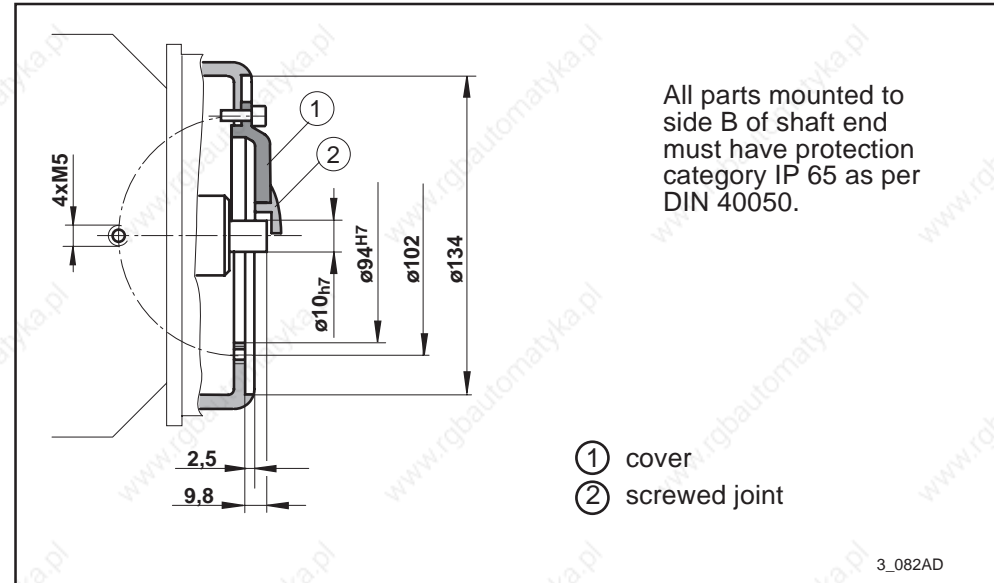

Fig. 3.8: Side B shaft end 2AD100

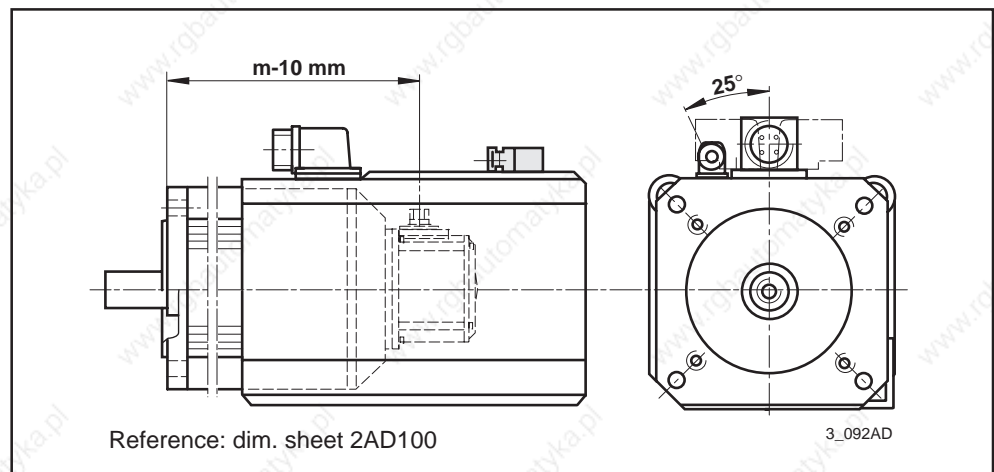

Fig. 3.9: 2AD100 with feedback types 6, 7

3.5. Type codes

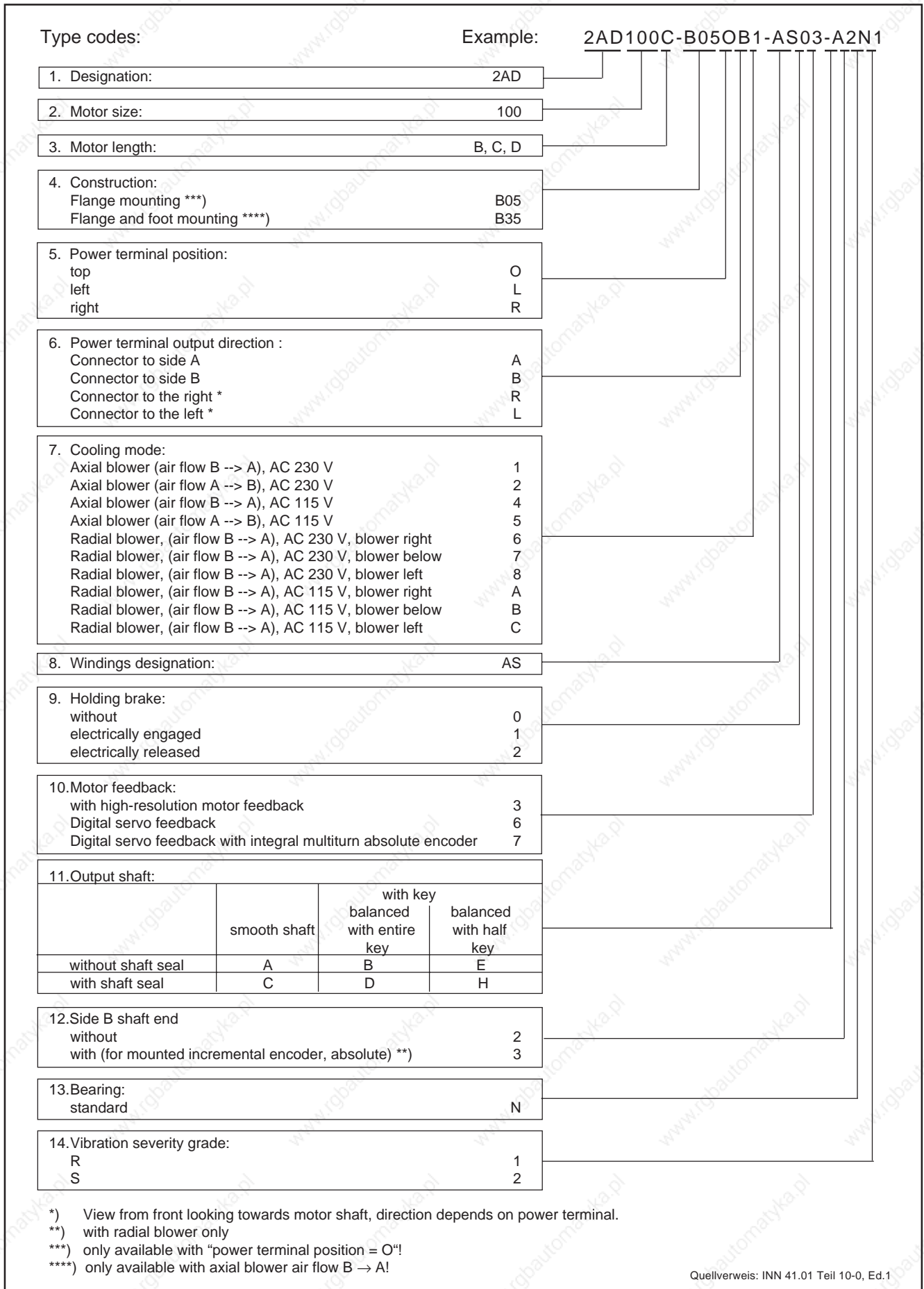

Fig. 3.10: Type codes 2AD100

Notes

4. Technical data - 2AD 101

4.1 Nominal data

Designation	Symbol	Unit	2AD101		
			C	D	
Motor size			C	D	
Windings designation			BD		BS
Nominal power ¹⁾	P_n	kW	7.5	9.5	
Nominal torque ¹⁾	M_n	Nm	48	60	
Base motor speed	n	min ⁻¹	1500		
Peak speed	n_{max}	min ⁻¹	9000		
Nominal current	I_n	A _{eff}	37	42	31
Nominal voltage	U_n	V _{eff}	166	187	259
Rotor inertia ²⁾	J_M	kgm ²	0.021	0.028	
Thermal time constant	t_{th}	min	40	45	
Min. connection cross section EN 60204, part 1 / 2/86	A	mm ²	10		
Average sound pressure level at 1 meter (PWM=4kHz)	L_p	dB(A)	70		
Mass ³⁾	m	kg	49	60	
Ambient temperature		°C	0° to 45°		
Insulation classification DIN VDE 0530 Teil 1			F		
Balance class ⁴⁾ DIN ISO 2373			R, S, S1		R, S
¹⁾ Values determined as per DIN VDE 0530, section 1 Characteristic operating curves are available for the listed nominal rates to help in the selection of the AC main spindle motor. These take operating modes S1, S2 and S6 into account. ²⁾ Values without holding brake. ³⁾ Values without holding brake, with blower. ⁴⁾ See Figure 2.7 "Vibrations in mm/s" for values.					

Fig. 4.1: Nominal data 2AD101

Permissible shaft load

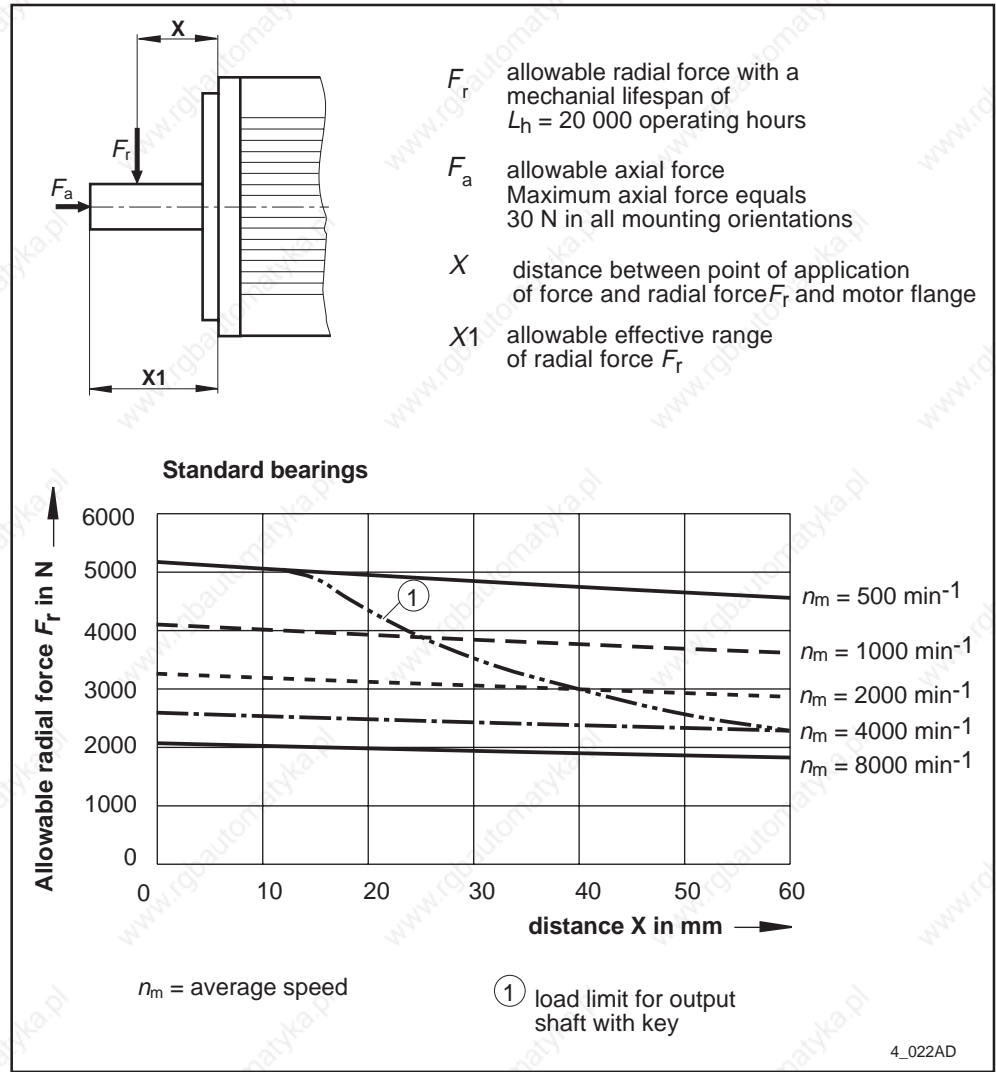

Fig. 4.2: Permissible shaft load 2AD101

Lubricant consumption

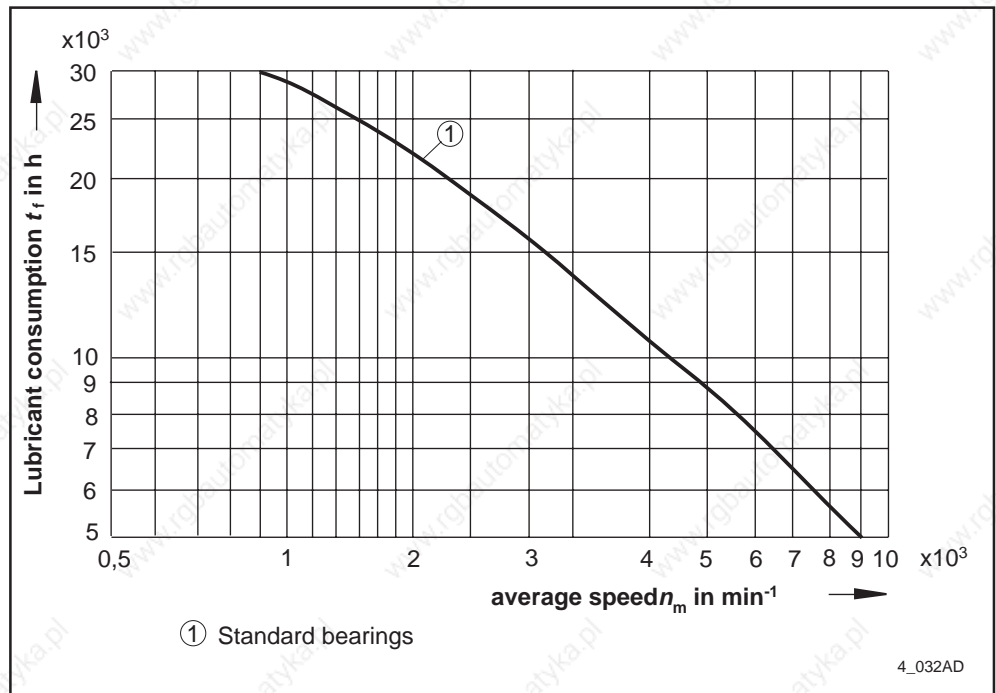

Fig. 4.3: Lubricant consumption duration 2AD101

4.2. Holding brake

Designation	Symbol	Unit	Version	
			electrically engaged	electrically released
Operating principle			30	24
Holding torque	M_h	Nm	30	24
Nominal terminal voltage	U_n	V	24 ± 10%	
Nominal current	I_n	A	0.9	
Moment of inertia	J_B	kgm ²	0.0007	
Maximum braking energy	W_{max}	Ws	20,000	
Peak speed	n_{max}	min ⁻¹	9000 ¹⁾	
Release delay	t_l	ms	50	100
Clamp delay	t_k	ms	50	60
Mass	m	kg	1,5	
<p>1) In the case of electrically-released holding brakes, the maximum speed is determined by the maximum braking energy, W_{max}, of the holding brake. It is calculated as follows:</p> $n_{max} = \sqrt{\frac{2 W_{max}}{J_M + J_B + J_C}} \cdot \frac{30}{3,14}$ <p> J_M rotor inertia J_B holding brake inertia J_L load inertia (attachments to the output shaft) </p>				

Fig. 4.4: Technical data of holding brake for 2AD101

4.3. Motor blower

Designation	Symbol	Unit	Version		
			Axial blower		
Air current			B → A blowing recommended	A → B suction	A → B suction
Power consumption	S_N	VA	50		55
Nominal voltage	U_N	V	230V, 50/60Hz±10%		115V, 50/60Hz±10%
Average air volume	V	m ³ /h	460		

Fig. 4.5: Technical data of motor blower for 2AD101

4.4 Dimensional data

Motor with axial blower and feedback types B05

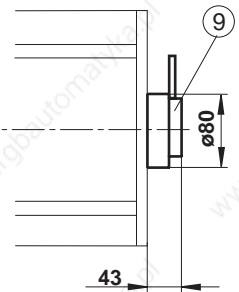
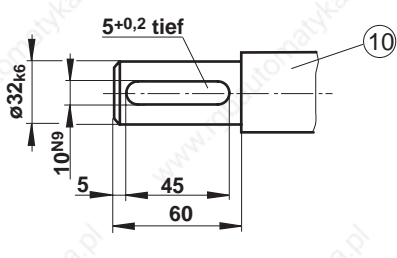
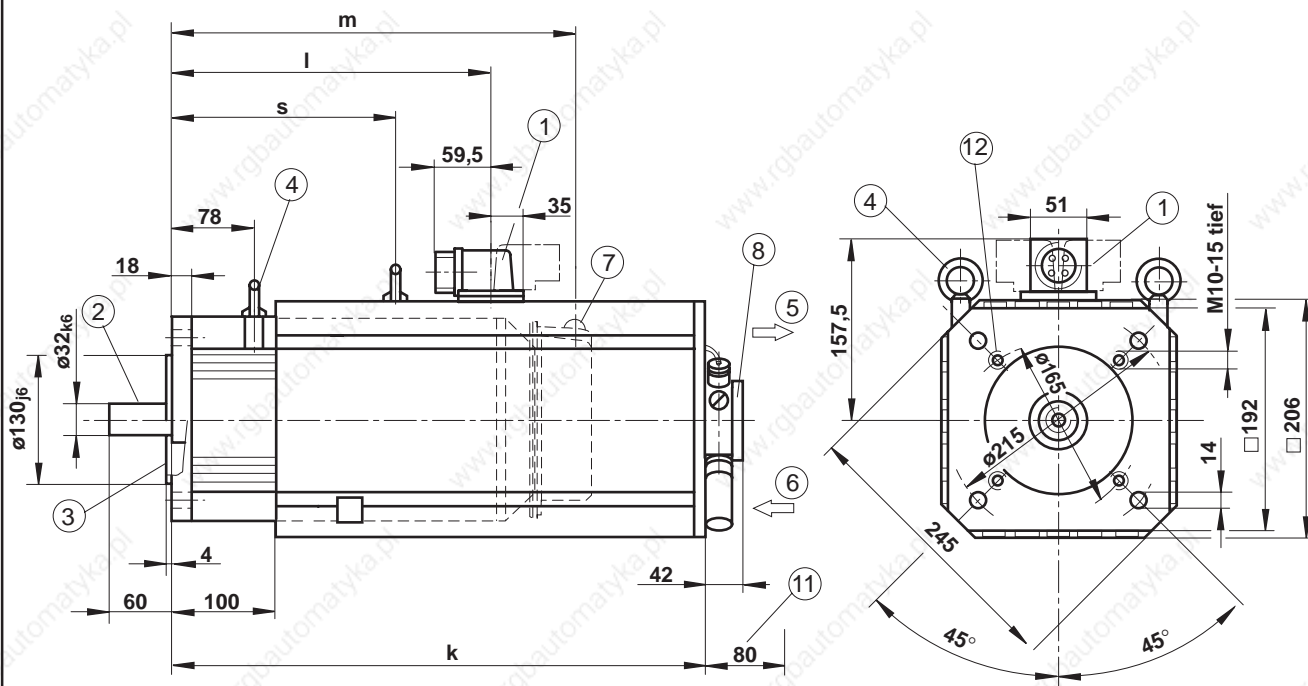

Dim.:	2AD101C	2AD101D
k	565	640
l	331	406
m	424,5	499,5
s	241	316

Tolerances:

Dim. to	6	30	120	400	1000	2000
Tolerance	$\pm 0,1$	$\pm 0,2$	$\pm 0,3$	$\pm 0,5$	$\pm 0,8$	$\pm 1,2$

- ① Power connection
- ② Plain shaft end tolerance
DIN 42955 - R
center drill hole on front
DIN 332 - DS M8x19
- ③ flange dimensions per
DIN 42948
- ④ ring screw M8 - DIN 580
- ⑤ air flow A → B
- ⑥ air flow B → A
- ⑦ Motor feedback connection type 3
(flange socket), arranged per position
of power connection
- ⑧ motor blower connection:
connector turnable by 90°
- ⑨ Motor blower connection
- ⑩ output shaft with key;
concen. tolerance: DIN 42955 - R;
corresponding keyway:
DIN 6885 - A 10 x 8 x 45
- ⑪ Mounting distance (minimum
for pulling in ventilating air)
- ⑫ thread holes for mounting type
B14 (Standard)

For available version see Fig. 4.7 - type codes

4_06101

Fig. 4.6: Dimensional data 2AD101

4.5 Type codes

Type codes: Example: **2AD101C-B05OB1-AS03-A2N1**

1. Designation:	2AD		
2. Motor size:	101		
3. Motor length:	C, D		
4. Construction: Flange mounting	B05		
5. Power terminal position: top	O		
6. Power terminal output direction :			
	with terminal box on blower	with connector on blower	
Connector to side A	A	C	
Connector to side B	B	D	
Connector to the right *	R	E	
Connector to the left *	L	F	
7. Cooling mode:			
Axial blower (air flow B --> A), AC 230 V		1	
Axial blower (air flow A --> B), AC 230 V		2	
Axial blower (air flow A --> B), AC 115 V		5	
8. Windings designation:			
2AD101C		BD	
2AD101D		BD, BS	
9. Holding brake:			
no holding brake		0	
electrically engaged		1	
electrically released		2	
10. Motor feedback: with high-resolution motor feedback		3	
11. Output shaft:			
	smooth shaft	with key	
		balanced with entire key	
		balanced with half key	
without shaft seal	A	B	E
with shaft seal	C	D	H
12. Side B shaft end: without			2
13. Bearing: standard			N
14. Vibration severity grade:			
R			1
S			2
S1 **)			3

*) View from front looking towards motor shaft, direction depends on power terminals.
**) not available with motor length "D"

Quellverweis: INN 41.01 Teil 10-1, Ed.1

Fig. 4.7: Type codes 2AD101

Notes

5. Technical data 2AD104

5.1 Nominal data

Designation	Symbol	Unit	2AD132			
			B	C	D	
Motor size			B	C	D	
Windings designation			CS	ES	FS	
Nominal power ¹⁾	P_n	kW	4,5	7,5	10,0	10,0
Nominal torque ¹⁾	M_n	Nm	29	48	64	
Base motor speed	n	min ⁻¹	1500			
Peak speed	n_{max}	min ⁻¹	9000			
Nominal current	I_n	A _{eff}	12,0	19,9	22,3	28,4
Nominal voltage	U_n	V _{eff}	330	321	390	303
Rotor inertia ²⁾	J_M	kgm ²	0,014	0,021	0,028	
Thermal time constant	t_{th}	min	35	40	45	
Min. connection cross section of Indramat cables (INK...)	A	mm ²	1,5	2,5	4	4
Average sound pressure level at 1 meter (PWM=4kHz)	L_p	dB(A)	70			
Mass ³⁾	m	kg	37	49	60	
Ambient temperature		°C	0 ... 45			
Insulation classification DIN VDE 0530 Teil 1			F			
Balance class ⁴⁾ DIN ISO 2373			R, S, S1			R, S
¹⁾ Values determined as per DIN VDE 0530, section 1 Characteristic operating curves are available for the listed nominal rates to help in the selection of the AC main spindle motor. These take operating modes S1, S2 and S6 into account. ²⁾ Values without holding brake. ³⁾ Values without holding brake, with blower. ⁴⁾ See Figure 2.7 "Vibrations in mm/s" for values.						

Fig. 5.1: Nominal data 2AD104

Permissible shaft load

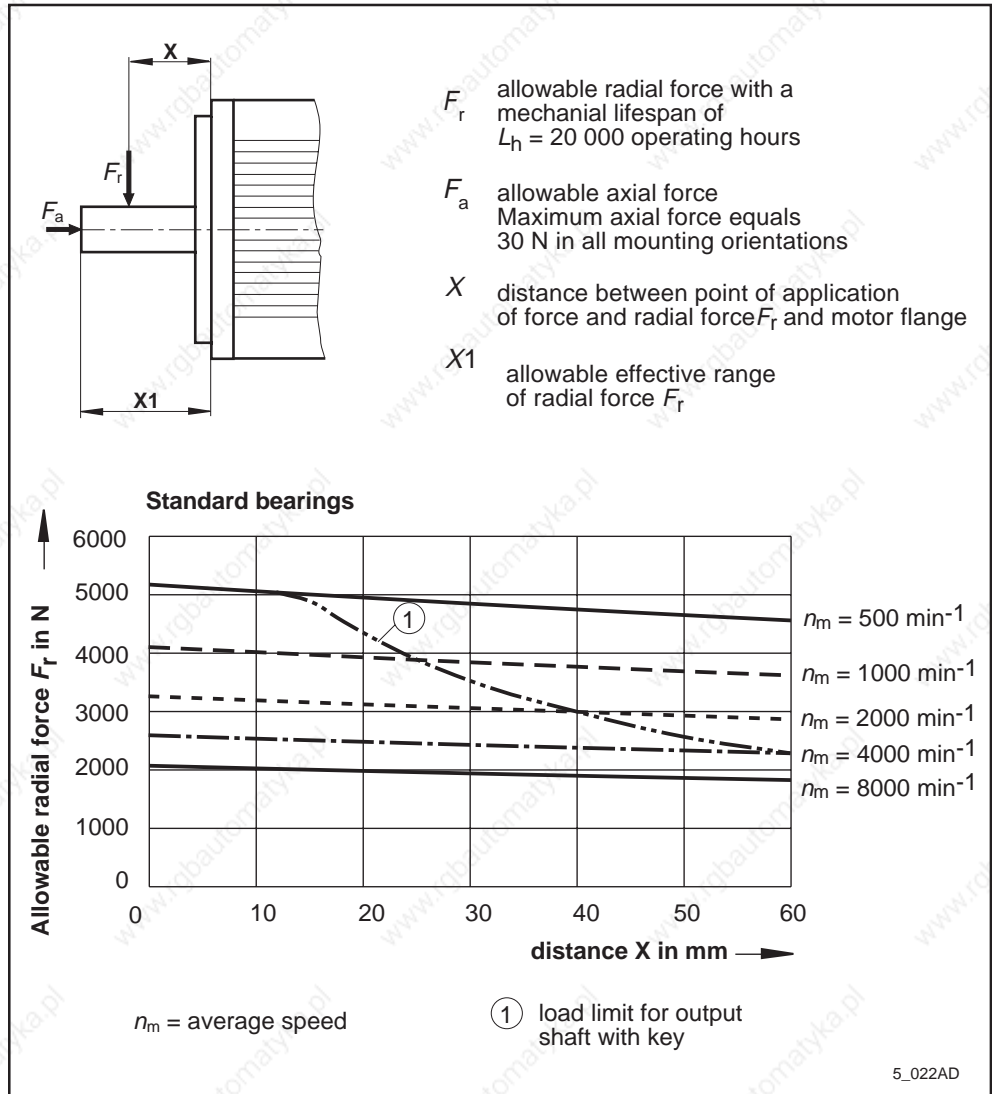

Fig. 5.2: Permissible shaft load 2AD104

Lubricant consumption

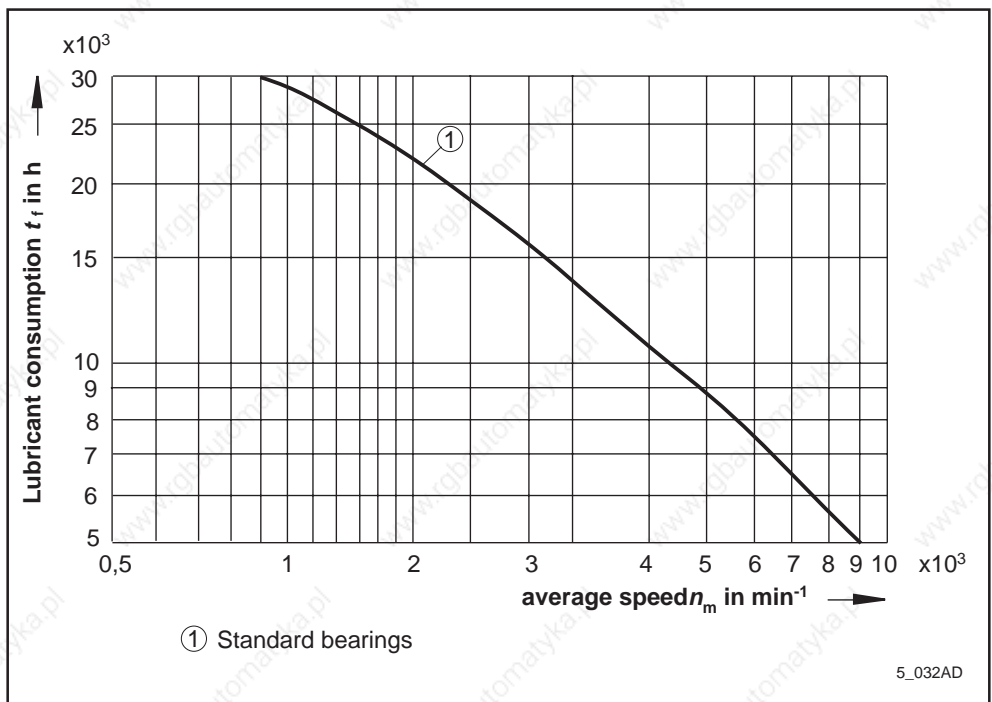

Fig. 5.3: Lubricant consumption duration 2AD104

5.2. Holding brake

Designation	Symbol	Unit	Version	
			electrically engaged	electrically released
Operating principle			30	24
Holding torque	M_h	Nm	30	24
Nominal terminal voltage	U_n	V	24 ± 10%	
Nominal current	I_n	A	0,9	
Moment of inertia	J_B	kgm ²	0,0007	
Maximum braking energy	W_{max}	Ws	20000	
Peak speed	n_{max}	min ⁻¹	9000 1)	
Release delay	t_l	ms	50	100
Clamp delay	t_k	ms	50	60
Mass	m	kg	1,5	
<p>1) In the case of electrically-released holding brakes, the maximum speed is determined by the maximum braking energy, W_{max}, of the holding brake. It is calculated as follows:</p> $n_{max} = \sqrt{\frac{2 W_{max}}{J_M + J_B + J_C}} \cdot \frac{30}{3,14}$ <p> J_M rotor inertia J_B holding brake inertia J_L load inertia (attachments to the output shaft) </p>				

Fig. 5.4: Technical data of holding brake for 2AD104

5.3 Motor blower

Designation	Symbol	Unit	Version		
			axial blower		radial blower
Air current			B → A blowing recommended	A → B suction	B → A blowing
Power consumption	S_N	VA	60	70	60
Nominal voltage	U_N	V	230 or 115V, 50/60 Hz, ±10%		
Average air volume	V	m ³ /h	230		

Fig. 5.5: Technical data of motor blower for 2AD104

5.4 Dimensional data

Motor with axial blower, B05, B35

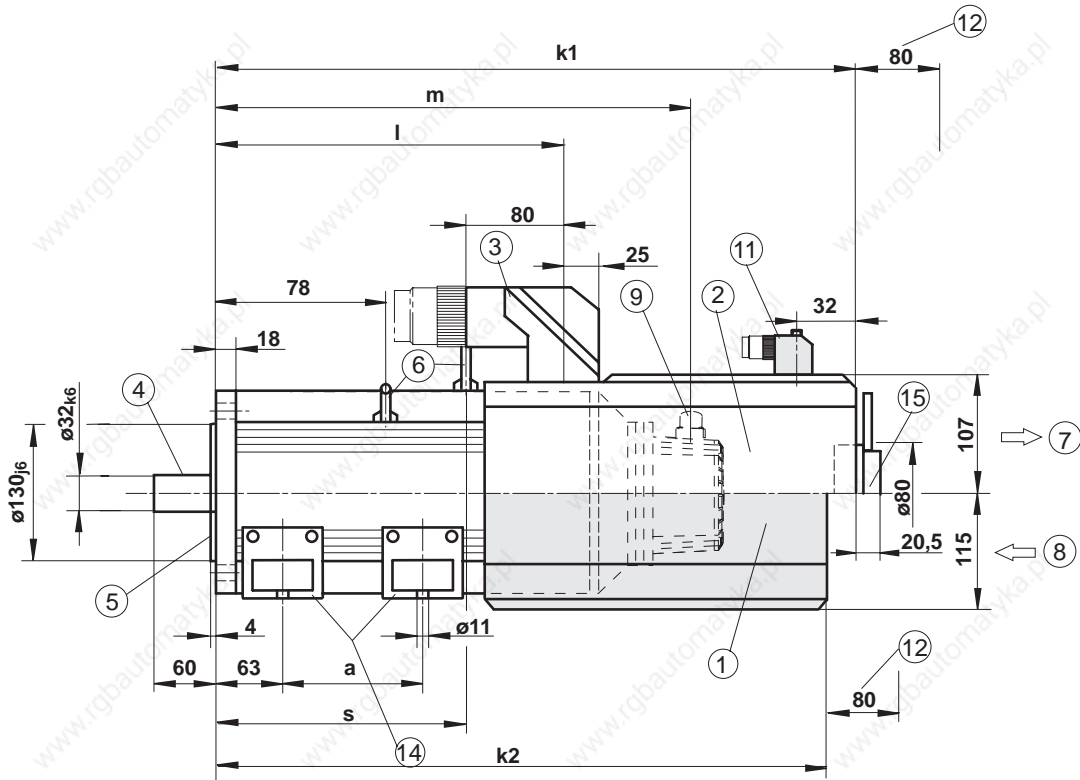

Motor with radial blower, B05

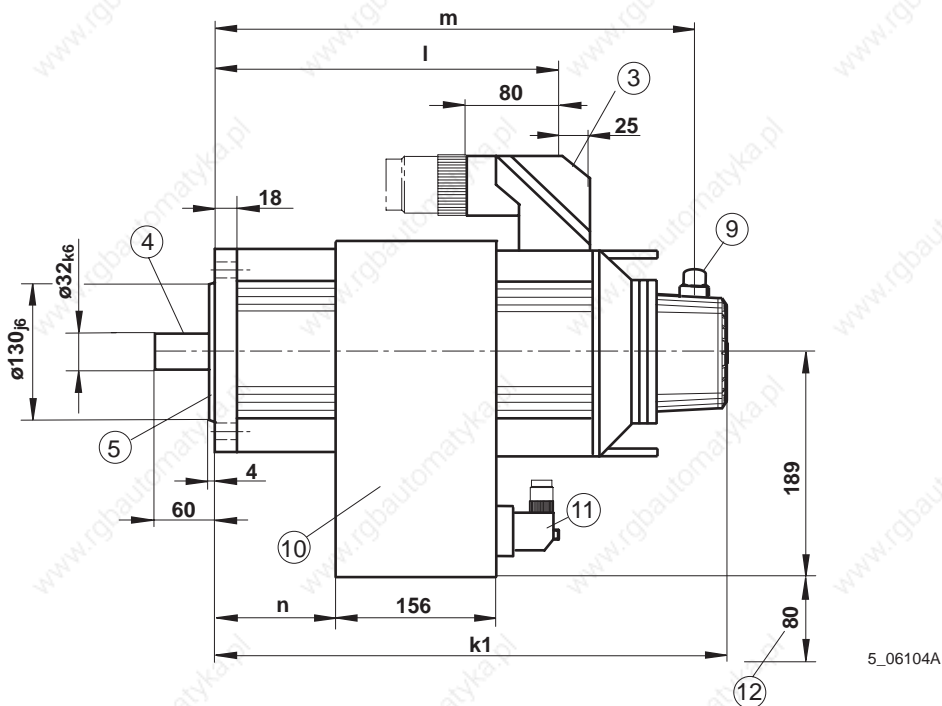

5_06104A

5. Technical data 2AD104

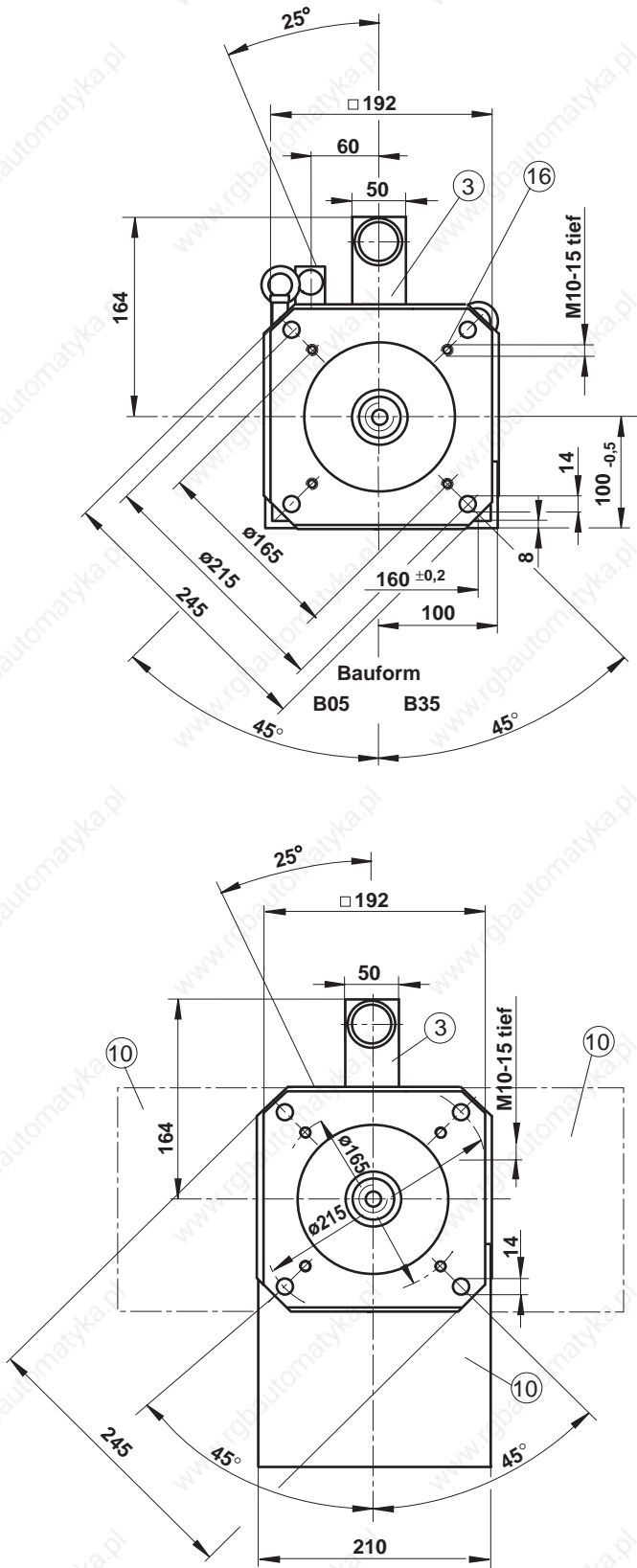

Dim.:	2AD104B	2AD104C	2AD104D
k1	538	613	688
k2	507	582	657
k	372	447	522
l	247	322	397
m	339	414	489
n	63	138	213
a	80	140	215
s	166	241	316

- ① Axial blower air stream B → A blowing
Blower connection: connector turnable by 90°
- ② Axial blower air flow A → B suction
Blower connection: terminal box with cable threaded joint.
- ③ Power connection
- ④ Plain shaft end tolerance
DIN 42955 - R
center drill hole on front
DIN 332 - DS M8x19
- ⑤ flange dimensions per
DIN 42948
- ⑥ ring screw M8 - DIN 580
- ⑦ air flow A → B
- ⑧ air flow B → A
- ⑨ Motor feedback connection type 3
(flange socket), arranged per position
of power connection
- ⑩ Radial blower;
position of radial blower may
not be the same as power connection
- ⑪ motor blower connection:
connector turnable by 90°
- ⑫ Mounting distance (minimum
for pulling in ventilating air)
- ⑭ type B35 (flange and foot mounting)
only with axial blower, air flow B → A
- ⑮ Motor blower connection with suction
- ⑯ thread holes for mounting type
B14 (Standard)

Tolerances:

Dim. to	6	30	120	400	1000	2000
Tolerance	±0,1	±0,2	±0,3	±0,5	±0,8	±1,2

For available version see Fig. 5.8 - type codes

5_06104B

Fig. 5.6: Dimensional data 2AD104

5. Technical data 2AD104

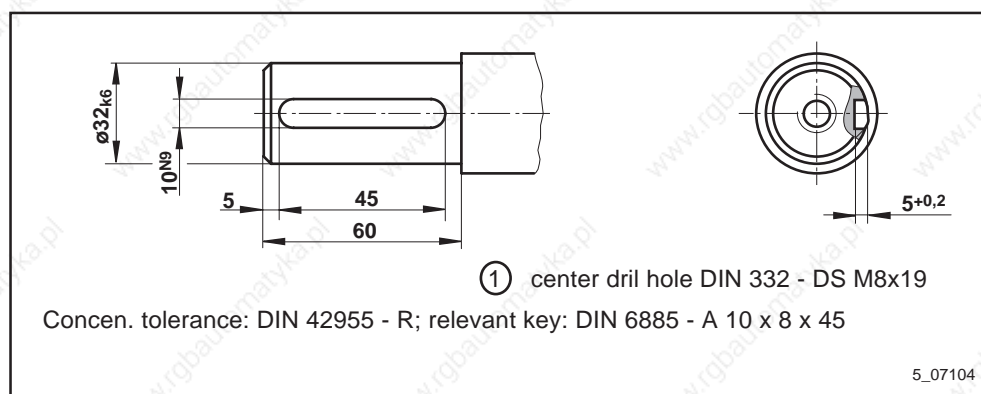

Fig. 5.7: Output shaft with key for 2AD104

5.5 Type codes

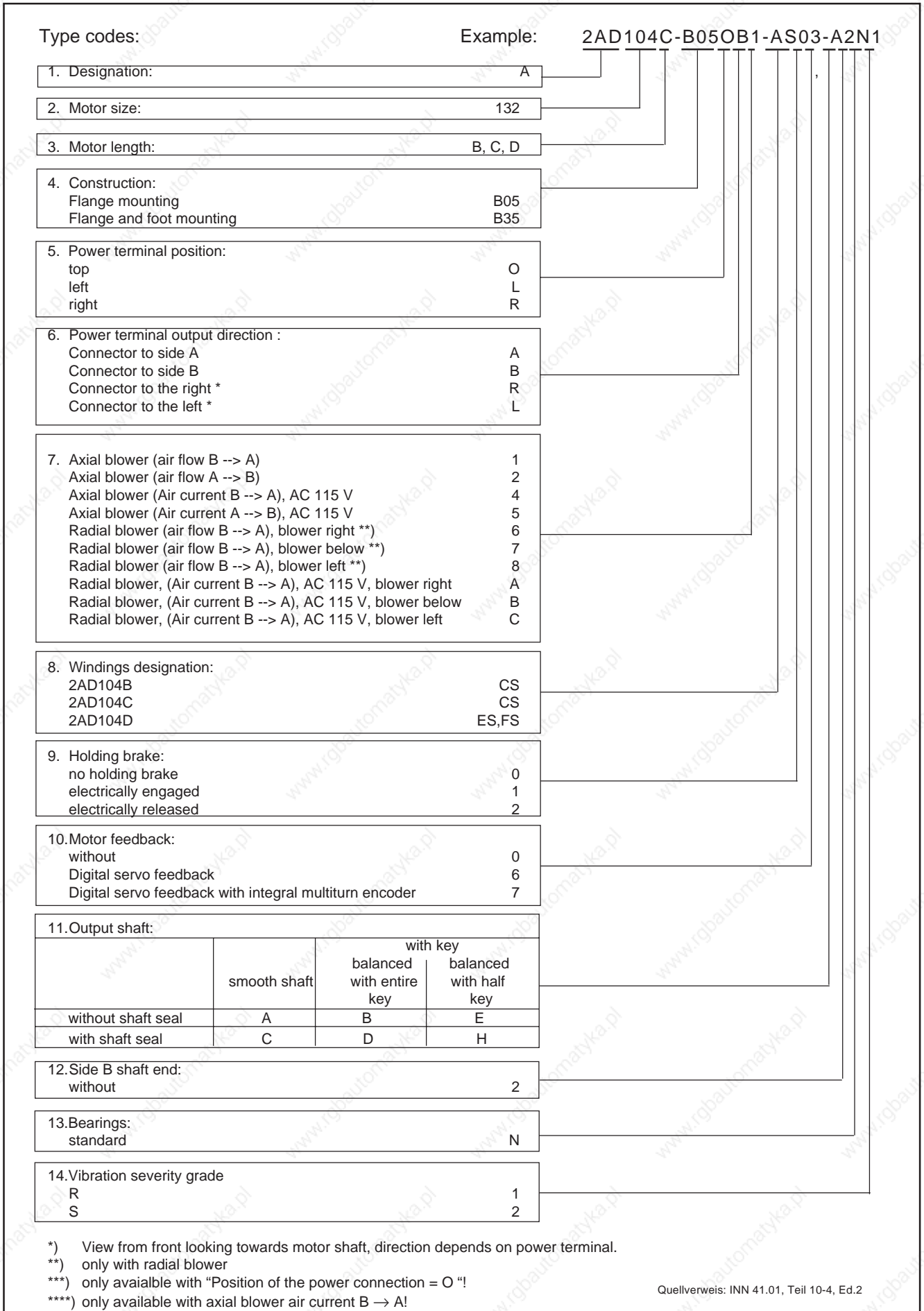

Fig. 5.8: Type codes 2AD104

Notes

6. Technical data - 2AD 132

6.1 Nominal data

Designation	Symbol	Unit	2AD132					
			B		C		D	
Motor size			B		C		D	
Windings designation			DS	BS		CS	BD	AS
Nominal power ¹⁾	P_n	kW	10		15		22	
Nominal torque ¹⁾	M_n	Nm	64		96		140	
Base motor speed	n	min ⁻¹	1500					
Peak speed	n_{max}	min ⁻¹	7500					
Nominal current	I_n	A _{eff}	30	45	65	39	80	54
Nominal voltage	U_n	V _{eff}	258	168	167	279	217	290
Rotor inertia ²⁾	J_M	kgm ²	0.054		0.076		0.118	
Thermal time constant	t_{th}	min	45		50		55	
Min. connection cross section EN 60204, part 1 / 2/86	A	mm ²	10	16	10	25	16	
Average sound pressure level at 1 meter (PWM=4kHz)	L_p	dB(A)	75					
Mass ³⁾	m	kg	90		115		135	
Ambient temperature		°C	0 ... 45					
Insulation classification DIN VDE 0530 Teil 1			F					
Balance class ⁴⁾ DIN ISO 2373			R, S, S1					
¹⁾ Values determined as per DIN VDE 0530, section 1 Characteristic operating curves are available for the listed nominal rates to help in the selection of the AC main spindle motor. These take operating modes S1, S2 and S6 into account. ²⁾ Values without holding brake. ³⁾ Values without holding brake, with blower. ⁴⁾ See Figure 2.7 "Vibrations in mm/s" for values.								

Fig. 6.1: Nominal data 2AD132

Permissible shaft load

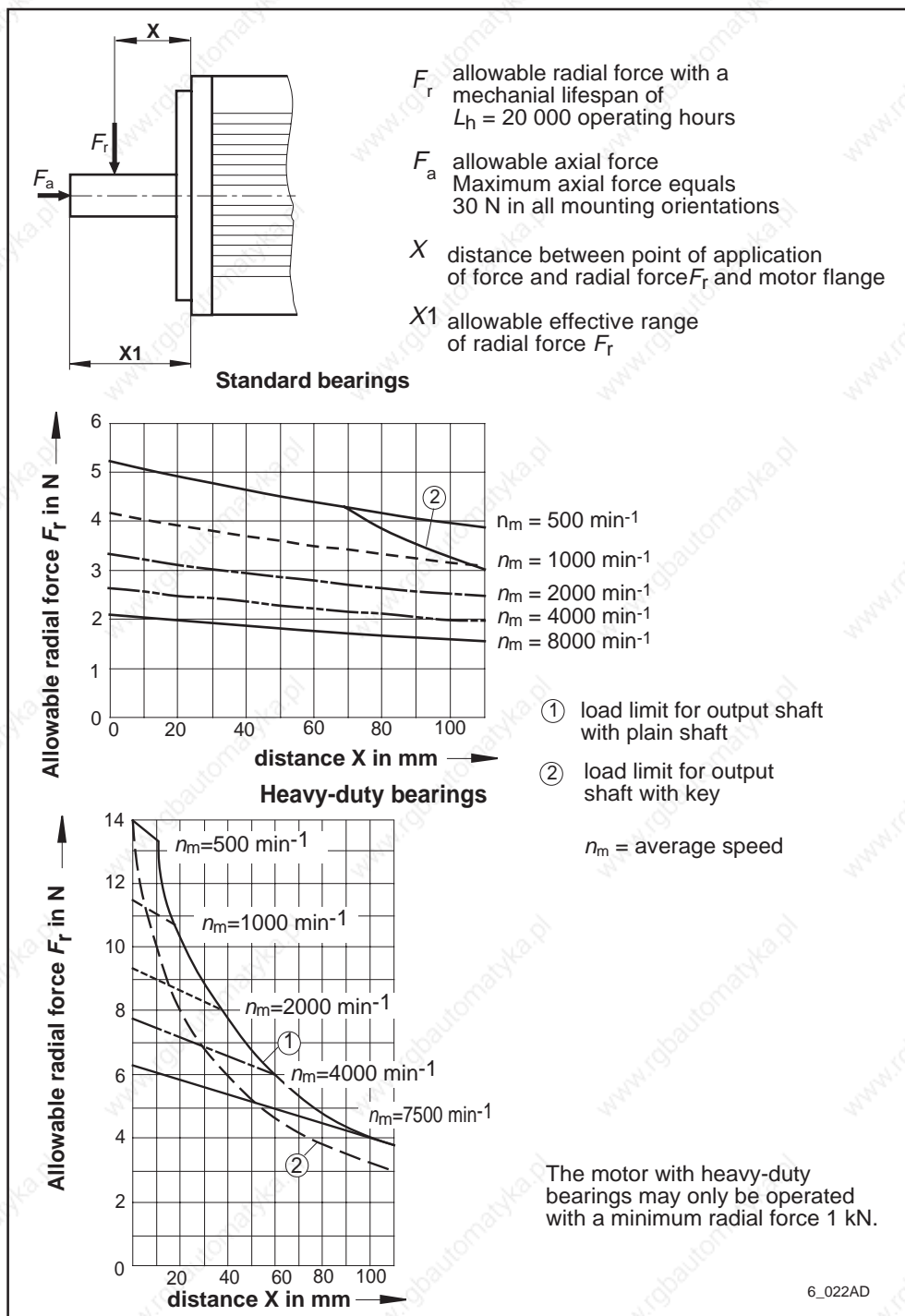

Fig. 6.2: Permissible shaft load 2AD132

Lubricant consumption

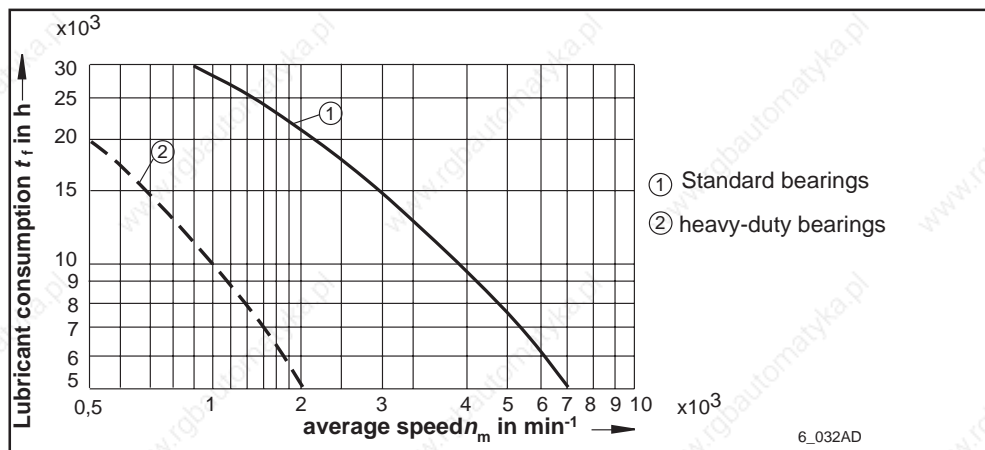

Fig. 6.3: Lubricant consumption duration 2AD132

6.2 Holding brake

Designation	Symbol	Unit	Version			
			electrically engaged	electrically released	electrically released heavy-duty	electrically released extra heavy-duty
Operating principle			electrically engaged	electrically released	electrically released heavy-duty	electrically released extra heavy-duty
Holding torque	M_h	Nm	100	30	100	140
Nominal terminal voltage ¹⁾	U_n	V	24 ± 10%			
Nominal current	I_n	A	1.5	1.3	1.8	2,8
Moment of inertia	J_B	kgm ²	0.002	0.0018	0.002	
Maximum braking energy	W_{max}	Ws	30000			
Peak speed	n_{max}	min ⁻¹	7500 ¹⁾			
Release delay	t_l	ms	140	120	110	
Clamp delay	t_k	ms	110	65	70	
Mass	m	kg	4			
<p>¹⁾ In the case of electrically-released holding brakes, the maximum speed is determined by the maximum braking energy, W_{max}, of the holding brake. It is calculated as follows:</p> $n_{max} = \sqrt{\frac{2 W_{max}}{J_M + J_B + J_C}} \cdot \frac{30}{3,14}$ <p> J_M rotor inertia J_B holding brake inertia J_L load inertia (attachments to the output shaft)) </p>						

Fig. 6.4: Technical data of holding brake for 2AD132

6.3 Motor blower

Designation	Symbol	Unit	Version		
			axial blower		radial blower
Air current			B → A blowing recommended	A → B suction	B → A blowing
Power consumption	S_N	VA	170 145		330
Nominal voltage	U_N	V	3 x 400 V, 50 Hz, ± 15 % 3 x 460 V, 60 Hz, ± 10 %		
Average air volume		V	m ³ /h		1000

Fig. 6.5: Technical data of motor blower for 2AD132

6.4 Dimensional data

Motor with axial blower and feedback type 3, B05, B35

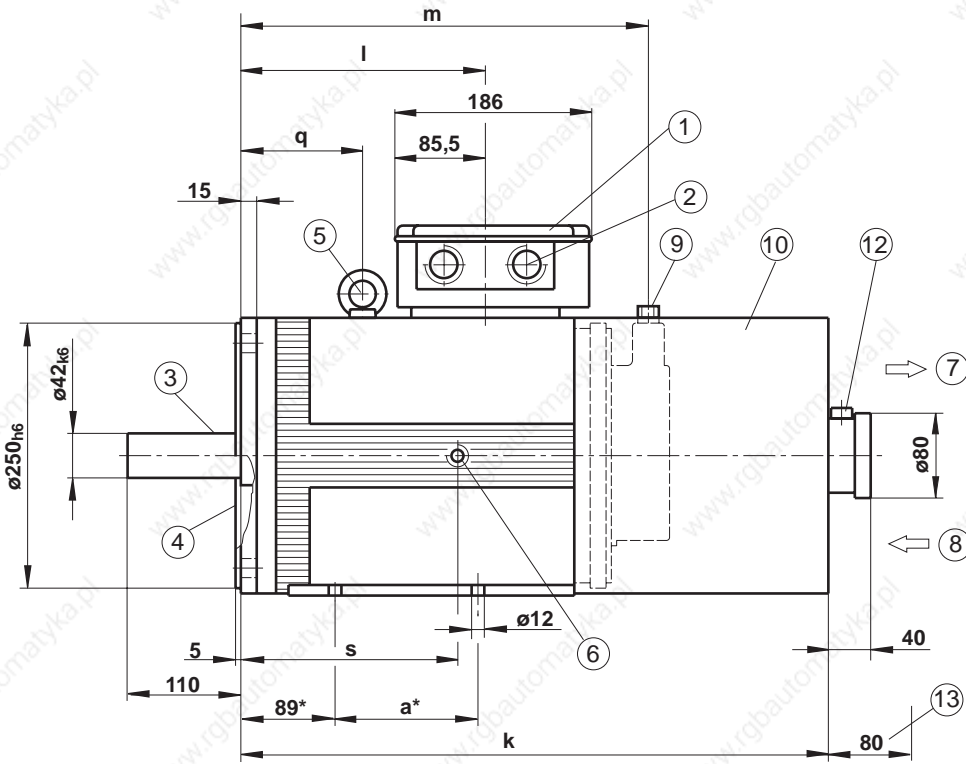

Motor with radial blower and feedback type 3, B05, B35

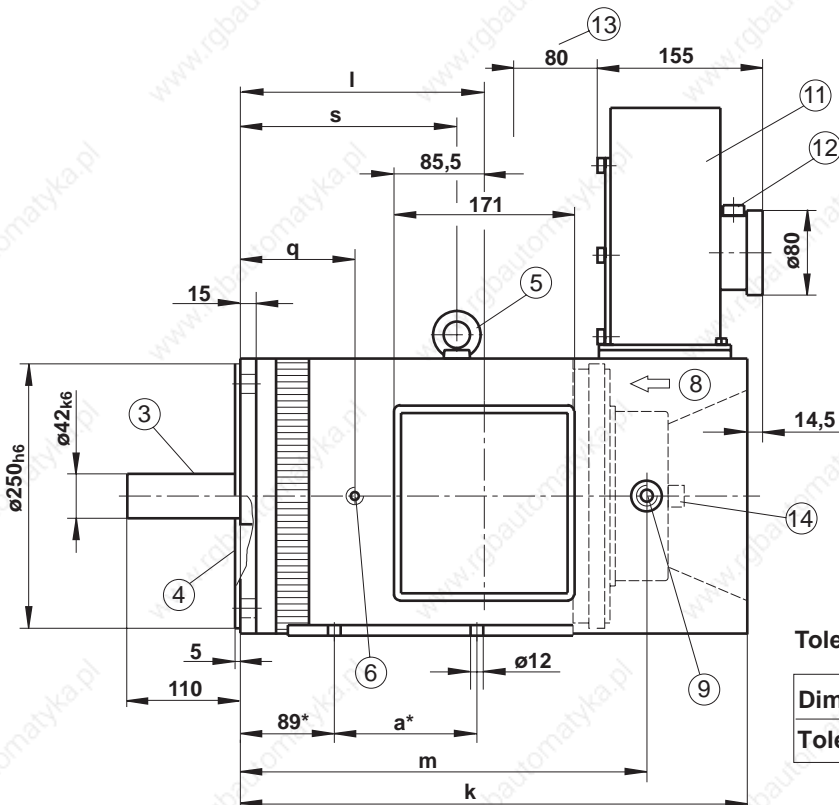

Tolerances

Dim. to	6	30	120	400	1000	2000
Tolerance	±0,1	±0,2	±0,3	±0,5	±0,8	±1,2

6_06132A

6. Technical data 2AD132

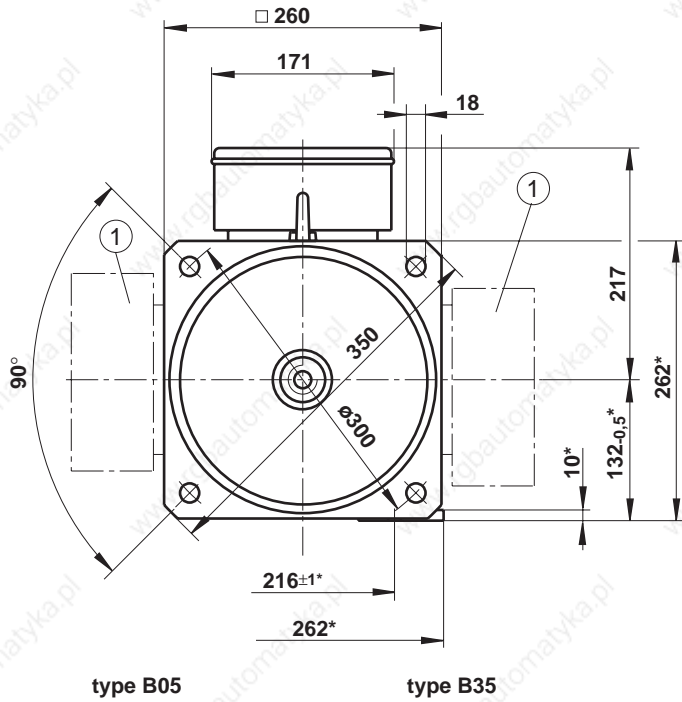

Dim.:	2AD132B	2AD132C	2AD132D
a*	135	205	335
w/o hold. brake	555	625	755
k with hold. brake	617	687	817
w/ hold. brake heavy-duty	663	733	863
l	231	301	431
w/o hold. brake	384,5	454,5	584,5
m with hold. brake	446,5	516,5	646,5
w/ hold. brake heavy-duty	492,5	562,5	692,5
q	115	185	275
s	205	230	275

* with foot mounting only, B35

- ① terminal box as power connection; arrangement can be selected, can be turned by 90 degrees, corresponds to output direction of power connection
- ② cable output: PG 29
- ③ plain shaft end concen. tolerance DIN 42955 - R on front center drill hole DIN 332 - DS M16x36
- ④ flange dimensions per DIN 42948
- ⑤ ring screw M10 - DIN 580
- ⑥ add. thread M10 for ring screw second thread opposite
- ⑦ air flow A → B
- ⑧ air flow B → A
- ⑨ Motor feedback connection type 3 (flange socket), arranged per position of power connection
- ⑩ axial blower
- ⑪ Radial blower; position of radial blower may not be the same as power connection
- ⑫ Motor blower connection: terminal box with cable screw joint
- ⑬ Mounting distance (minimum for pulling in ventilating air)
- ⑭ B-side shaft end: see Fig. 6.9 for dimensions

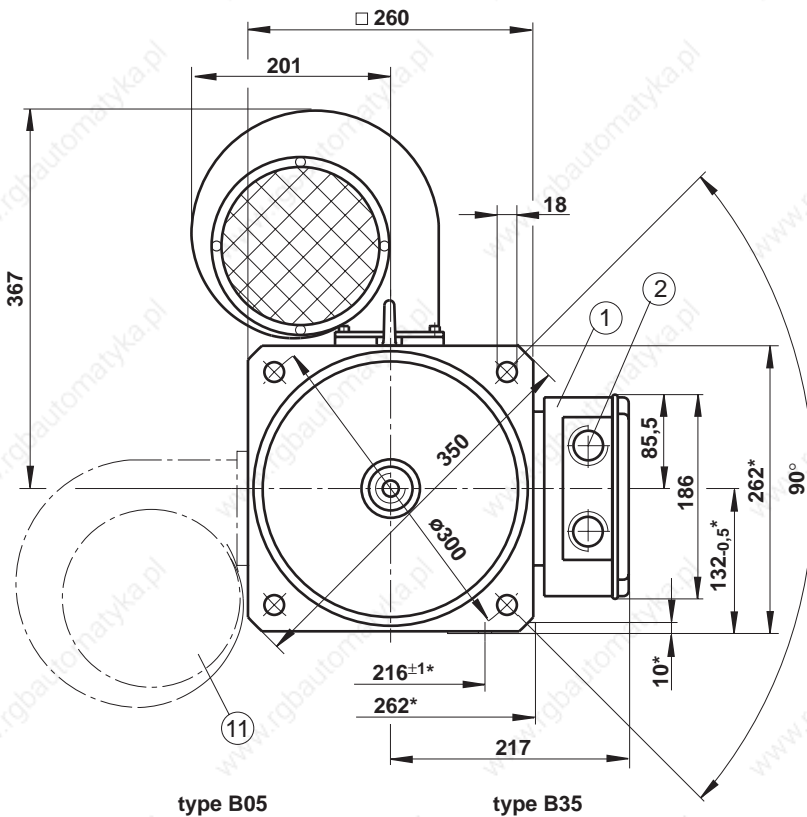

Dim.	2AD132B	2AD132C	2AD132D
a*	135	205	335
w/o hold. brake	480	550	680
k with hold. brake	542	612	742
w/ hold. brake heavy-duty	588	658	176
l	231	301	431
w/o hold. brake	384,5	454,5	584,5
m with hold. brake	446,5	516,5	646,5
w/ hold. brake heavy-duty	492,5	562,5	692,5
q	115	185	275
s	205	230	275

* Foot mounting only, B35

6_06132B

For available version see Fig. 6.3 - type codes

Fig. 6.6: Dimensional data 2AD132

6. Technical data 2AD132

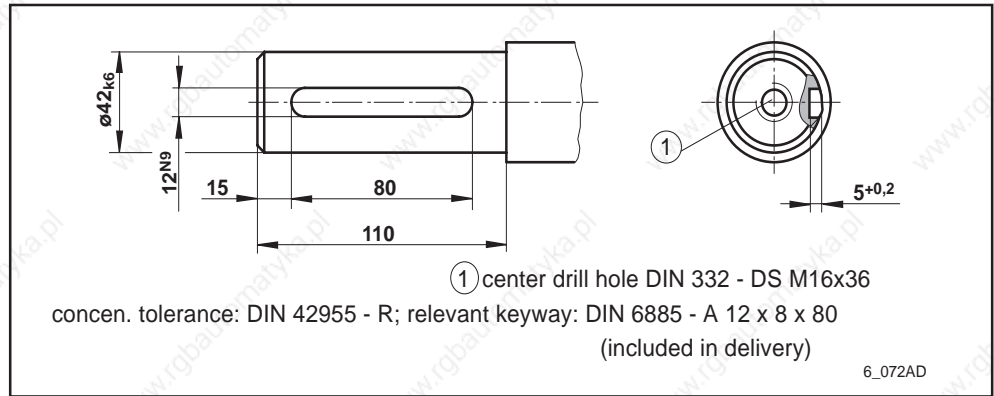

Fig. 6.7: Output shaft with key for 2AD132

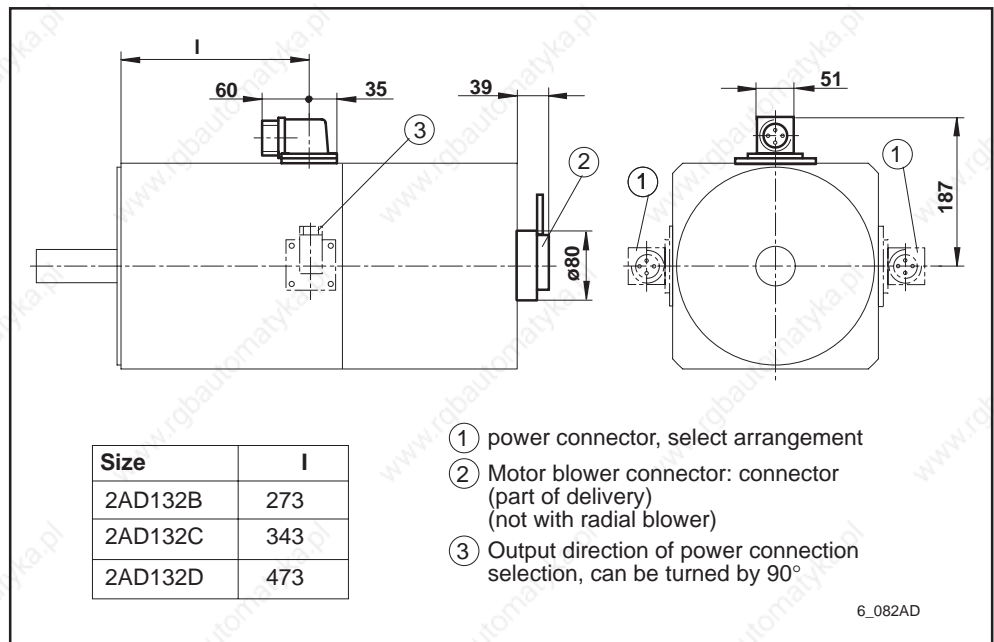

Fig. 6.8: Power connector 2AD132

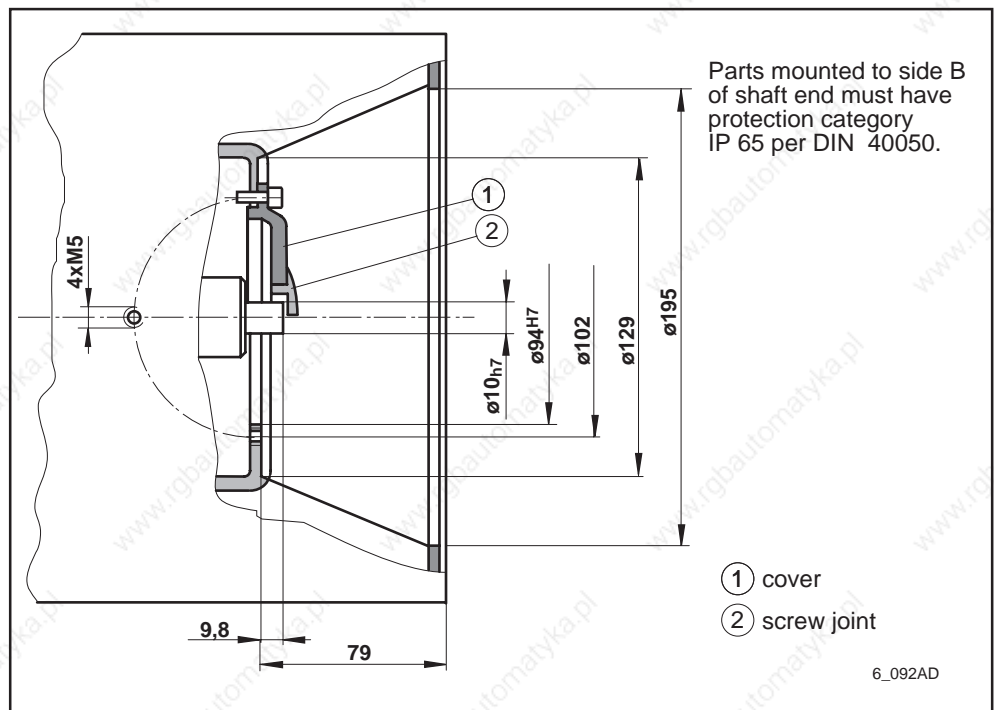

Fig. 6.9: Side B shaft end 2AD132

6. Technical data 2AD132

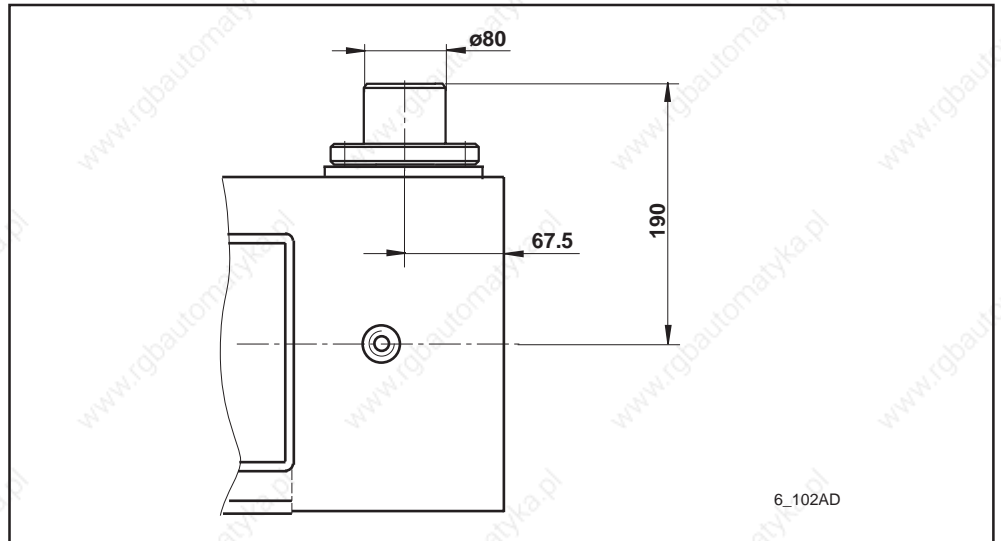

Fig. 6.10: 2AD132 with accessories M01 mounted 2AD132/134 (blower support base)

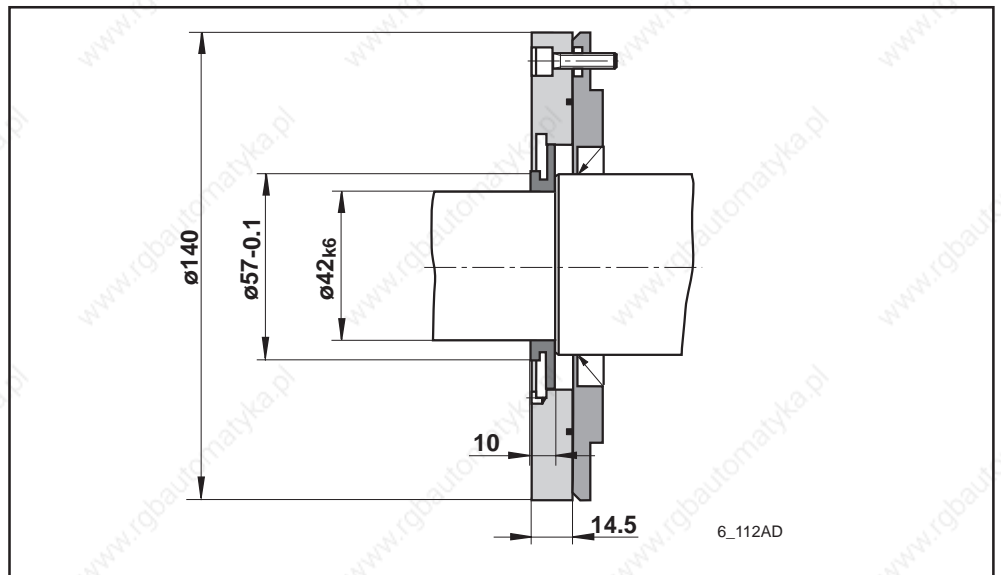

Fig. 6.11: 2AD132 with accessories M02 mounted 2AD132/134 (Labyrinth seal)

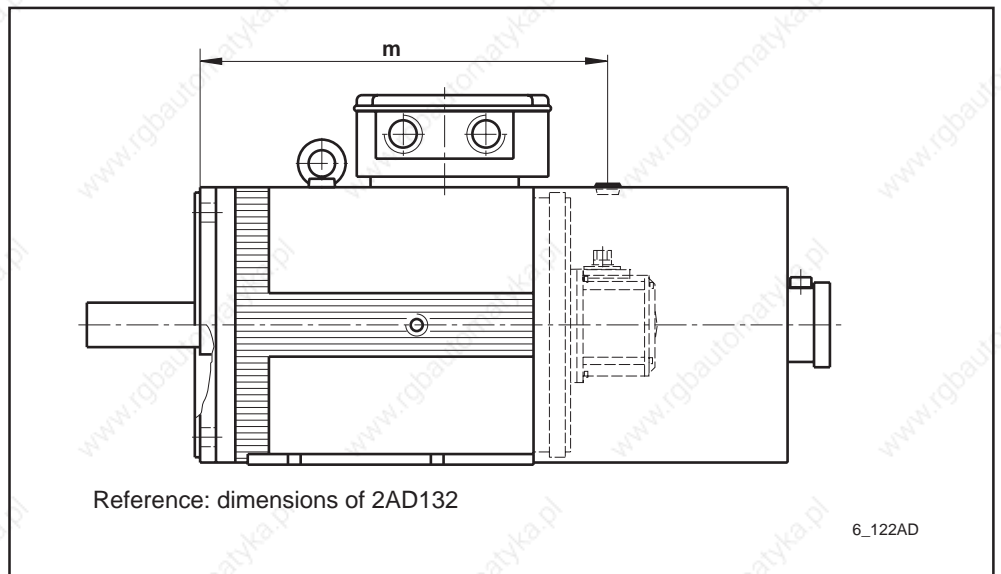

Fig. 6.12: 2AD132 with feedback types 6, 7

6.5 Type codes

Type codes:	Example:	2AD132C-B35OB1-BS03-A2N1
1. Designation:	2AD	2AD
2. Motor size:	132	132
3. Motor length:	B, C, D	B
4. Construction: Flange mounting Flange and foot mounting	B05 B35	B35
5. Power terminal position: top left right	O L R	O
6. Power terminal output direction :		
	terminal box connection (terminal box on blower)	connector (connector on blower)
to side A	A	C
to side B	B	-
to the right *	R	E
to the left *	L	F
7. Cooling mode: Axial blower (air flow B --> A) Axial blower (air flow A --> B) Radial blower (air flow B --> A), blower top **) Radial blower (air flow B --> A), blower right **) Radial blower (air flow B --> A), blower below **) Radial blower (air flow B --> A), blower left **)	1 2 3 6 7 8	1
8. Windings designation: 2AD132B 2AD132C 2AD132D	BS, DS BS, CS AS, BD	BS
9. Holding brake: no holding brake electrically engaged electrically released electrically released, heavy-duty electrically released, extra heavy-duty	0 1 2 3 4	0
10. Motor feedback: with high-resolution motor feedback Digital servo feedback Digital servo feedback with integral multiturn absolute encoder	3 6 7	3
11. Output shaft:		
	smooth shaft	with key balanced with entire key balanced with half key
without shaft seal	A	B E
with shaft seal	C	D H
12. Side B shaft end: without with (for mounted encoder - incremental and absolute) ***)	2 3	2
13. Bearings: standard heavy-duty	N V	N
14. Vibration severity grade R S S1 ****)	1 2 3	1

*) View from front looking towards motor shaft, direction depends on power terminal.
 **) Position of blower may not be same as that of power terminal.
 ***) Only available with radial blower and motor feedback "3"
 ****) not available with heavy-duty bearings

Quellverweis: 41.01 Teil 13-2, Ed. 1

Fig. 6.13: Type codes 2AD132

7. Technical data 2AD134

7.1 Nominal data

Designation	Symbol	Unit	2AD134			
			B	C	D	
Motor size			B		C	D
Windings designation			ES	FS	DS	CS
Nominal power ¹⁾	P_n	kW	12,0	12,0	18,0	26,0
Nominal torque ¹⁾	M_n	Nm	76		115	166
Base motor speed	n	min ⁻¹	1500			
Peak speed	n_{max}	min ⁻¹	7500			
Nominal current	I_n	A _{eff}	27,8	40,9	54,4	52
Nominal voltage	U_n	V _{eff}	328	224	248	387
Rotor inertia ²⁾	J_M	kgm ²	0,054		0,076	0,118
Thermal time constant	t_{th}	min	45		50	55
Min. connection cross section of Indramat cables (INK...)	A	mm ²	6	10	10	10
Average sound pressure level at 1 meter (PWM=4kHz)	L_p	dB(A)	75			
Mass ³⁾	m	kg	90	115	135	
Ambient temperature		°C	0 ... 45			
Insulation classification DIN VDE 0530 Teil 1			F			
Balance class ⁴⁾ DIN ISO 2373			R, S, S1			
¹⁾ Values determined as per DIN VDE 0530, section 1. Characteristic operating curves are available for the listed nominal rates to help in the selection of the AC main spindle motor. These take operating modes S1, S2 and S6 into account. ²⁾ Values without holding brake. ³⁾ Values without holding brake, with blower. ⁴⁾ See Figure 2.7 "Vibrations in mm/s" for values.						

Fig. 7.1: Nominal data 2AD134

Permissible shaft load

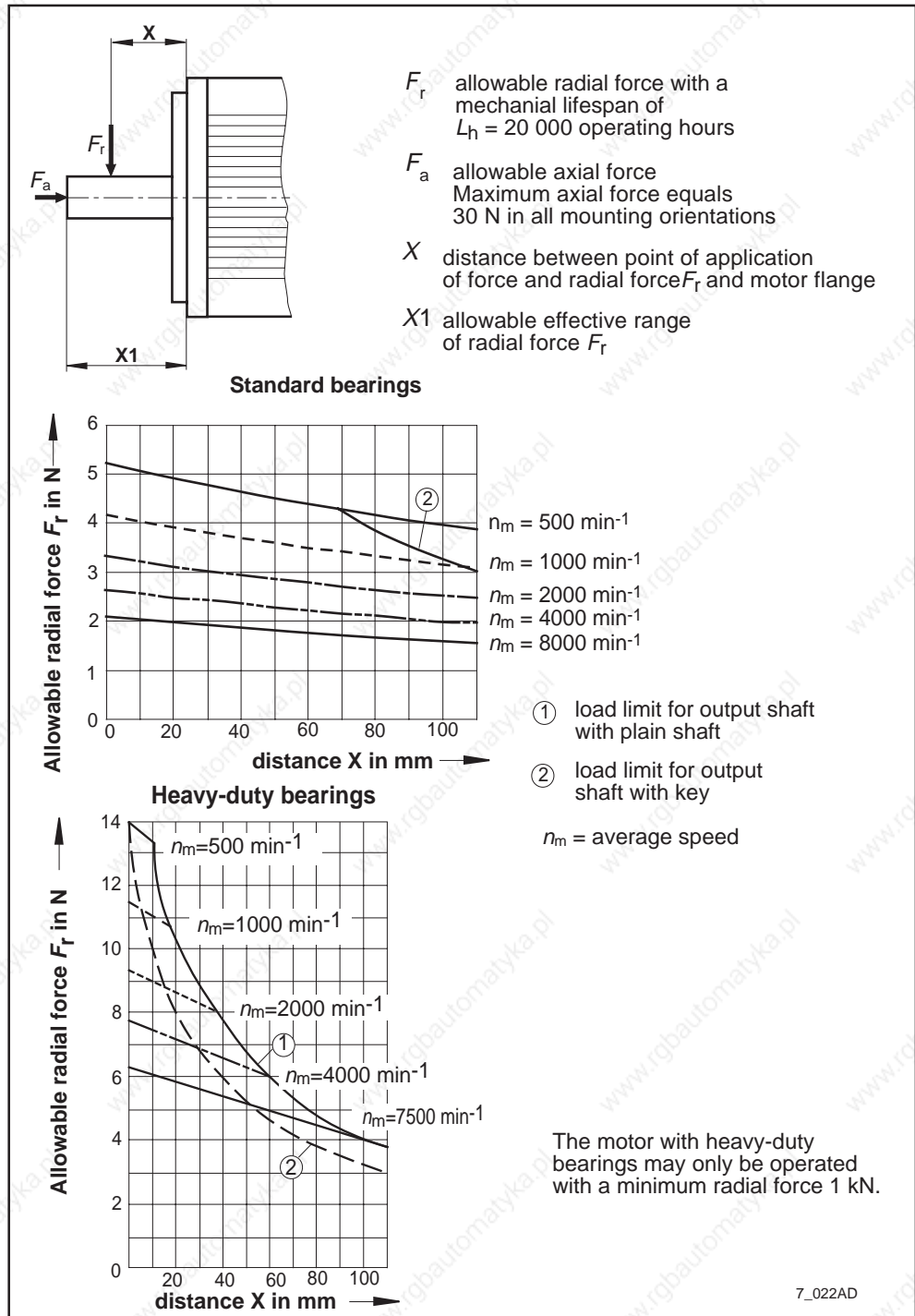

Fig. 7.2: Permissible shaft load 2AD134

Lubricant consumption

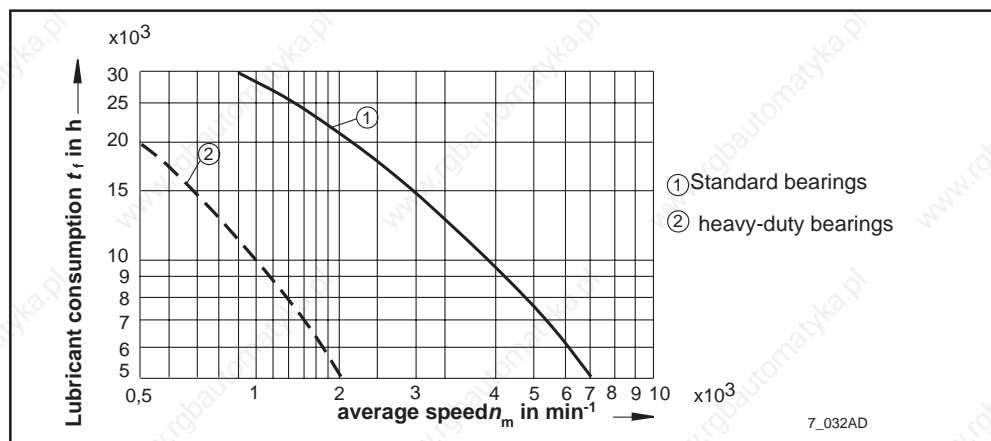

Fig. 7.3: Lubricant consumption duration 2AD134

7.2 Holding brake

Designation	Symbol	Unit	Version			
			electrically engaged	electrically released	electrically released heavy-duty	electrically released extra heavy-duty
Operating principle						
Holding torque	M_h	Nm	100	30	100	140
Nominal terminal voltage	U_n	V	24 ± 10%			
Nominal current	I_n	A	1,5	1,3	1,8	2,8
Moment of inertia	J_B	kgm ²	0,002	0,0018	0,002	
Maximum braking energy	W_{max}	Ws	30000			
Peak speed	n_{max}	min ⁻¹	7500 ¹⁾			
Release delay	t_l	ms	140	120	110	
Clamp delay	t_k	ms	110	65	70	
Mass	m	kg	4			
<p>¹⁾ In the case of electrically-released holding brakes, the maximum speed is determined by the maximum braking energy, W_{max}, of the holding brake. It is calculated as follows:</p> $n_{max} = \sqrt{\frac{2 W_{max}}{J_M + J_B + J_C}} \cdot \frac{30}{3,14}$ <p> J_M rotor inertia J_B holding brake inertia J_L load inertia (attachments to the output shaft) </p>						

Fig. 7.4: Technical data of holding brake for 2AD134

7.3 Motor blower

Designation	Symbol	Unit	Version		
			Axial blower		Radial lower
Air current			B → A blowing recommended	A → B suction	B → A blowing
Power consumption	S_N	VA	170 145		330
Nominal voltage	U_N	V	3 x 400 V, 50 Hz, ± 15 % 3 x 460 V, 60 Hz, ± 10 %		
Average air volume	V	m ³ /h	1000		

Fig. 7.5: Technical data of motor blower for 2AD134

7.4 Dimensional data

Motor with axial blower, type B05, B35

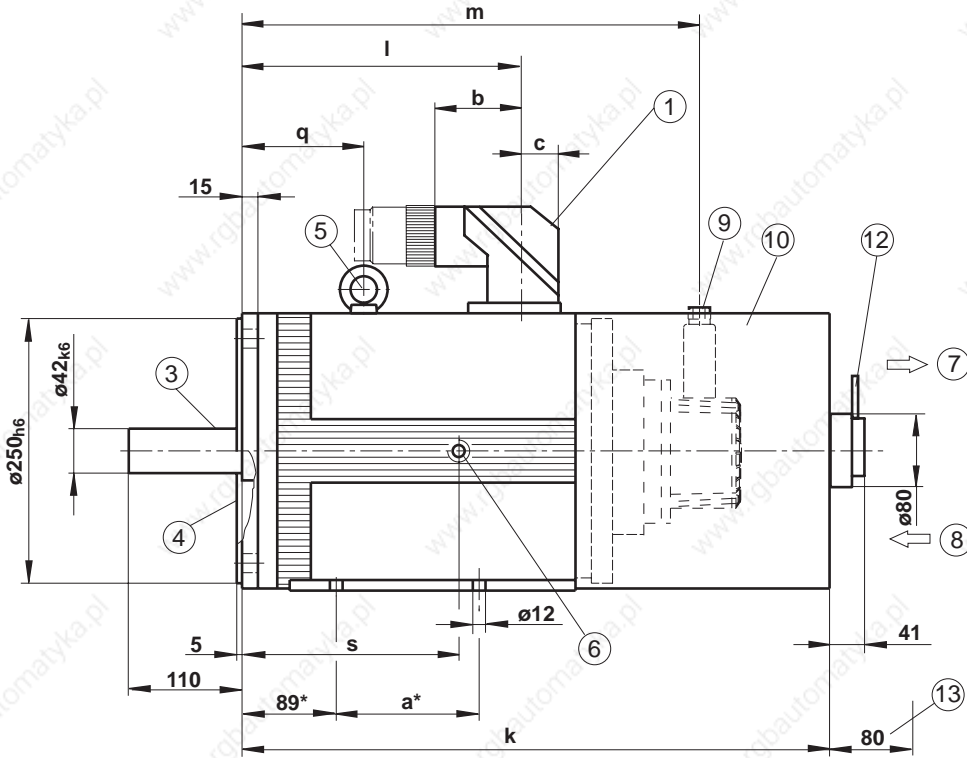

Motor with radial blower, type B05, B35

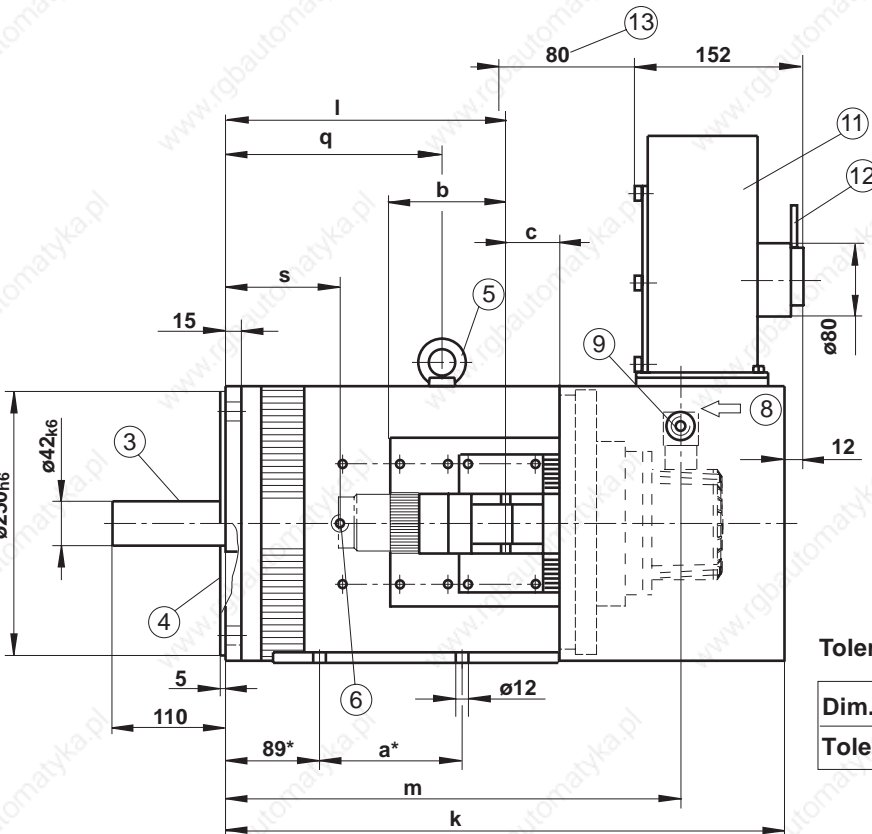

Tolerances:

Dim. to	6	30	120	400	1000	2000
Tolerance	±0,1	±0,2	±0,3	±0,5	±0,8	±1,2

7_06134A

7. Technical data 2AD134

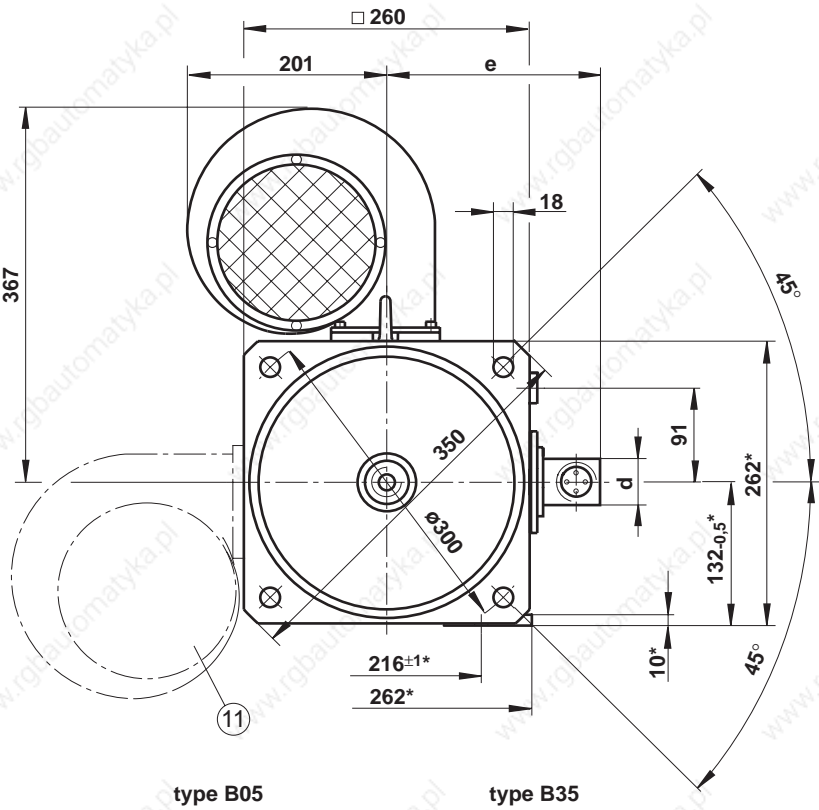
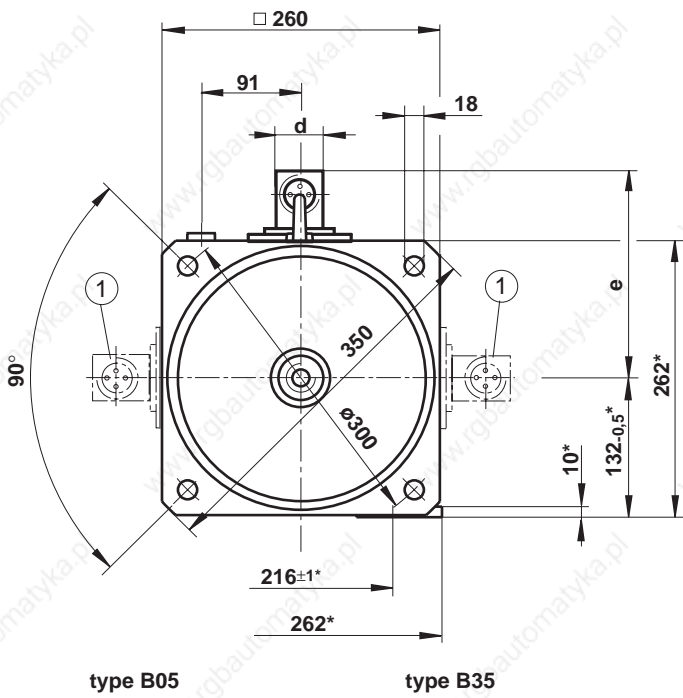

For available versions see Fig. 7.10 - Type codes

Dim.:	2AD134B	2AD134C	2AD134D
a*	135	205	335
b	80	84,5	84,5
c	25	35,5	35,5
d	50	71	71
e	204	206	206
w/o hold. brake	550	620	750
k with hold. brake	612	682	812
w/ hold. brake heavy-duty	658	728	858
l	274	335	465
w/o hold. brake	402	472	602
m with hold. brake	464	534	664
w/ hold. brake heavy-duty	510	580	710
q	115	185	275
s	205	230	275

* with foot mounting only, B35

- ① power connection, plug-in connection
- ③ plain shaft end concen. tolerance DIN 42955 - R on front center drill hole DIN 332 - DS M16x36
- ④ flange dimensions per DIN 42948
- ⑤ ring screw M10 - DIN 580
- ⑥ add. thread M10 for ring screw second thread opposite
- ⑦ air flow A → B
- ⑧ air flow B → A
- ⑨ Motor feedback connection type 3 (flange socket), arranged per position of power connection
- ⑩ axial blower
- ⑪ Radial blower; position of radial blower may not be the same as power connection
- ⑫ Motor blower connection: terminal box with cable screw joint
- ⑬ Mounting distance (minimum for pulling in ventilating air)

Dim.	2AD134B	2AD134C	2AD134D
a*	135	205	335
b	80	84,5	84,5
c	25	35,5	35,5
d	50	71	71
e	204	206	206
w/o hold. brake	480	550	680
k with hold. brake	542	612	742
w/ hold. brake heavy-duty	588	658	788
l	274	335	465
w/o hold. brake	402	472	602
m with hold. brake	464	534	664
w/ hold. brake heavy-duty	510	580	710
q	205	230	275
s	115	185	275

* Foot mounting only, B35

7_06134B

Fig. 7.6: Main spindle motor 2AD132 - Dimensional data

7. Technical data 2AD134

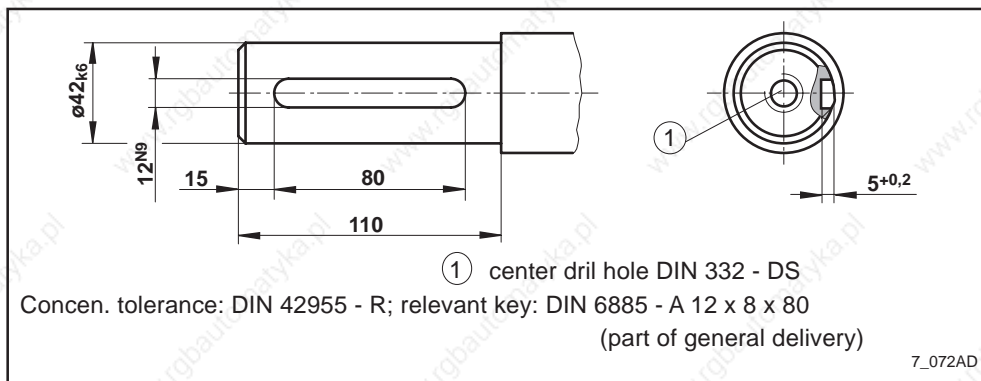

Fig. 7.7: Output shaft with key for 2AD134

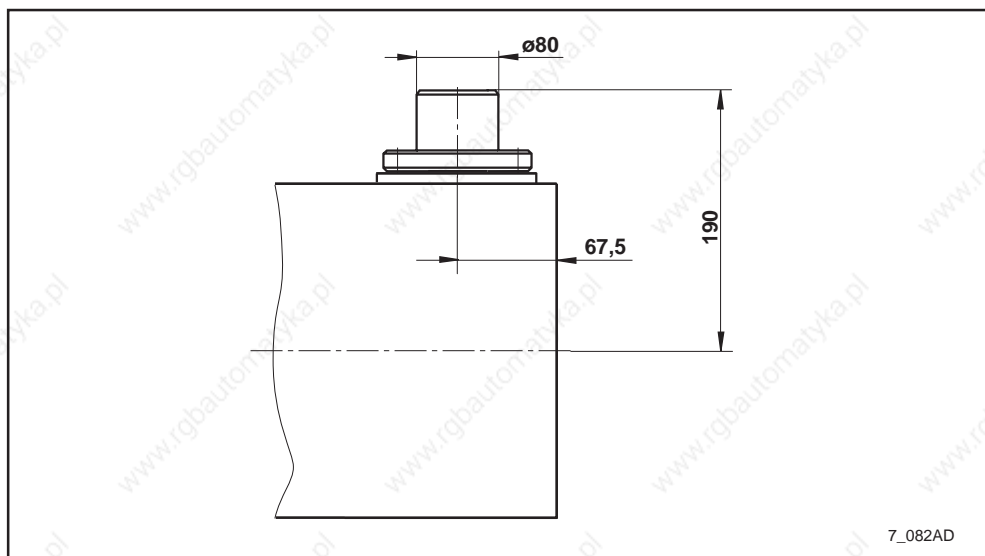

Fig. 7.8: 2AD134 with accessories mounted M01 2AD132/134 (Blower support base)

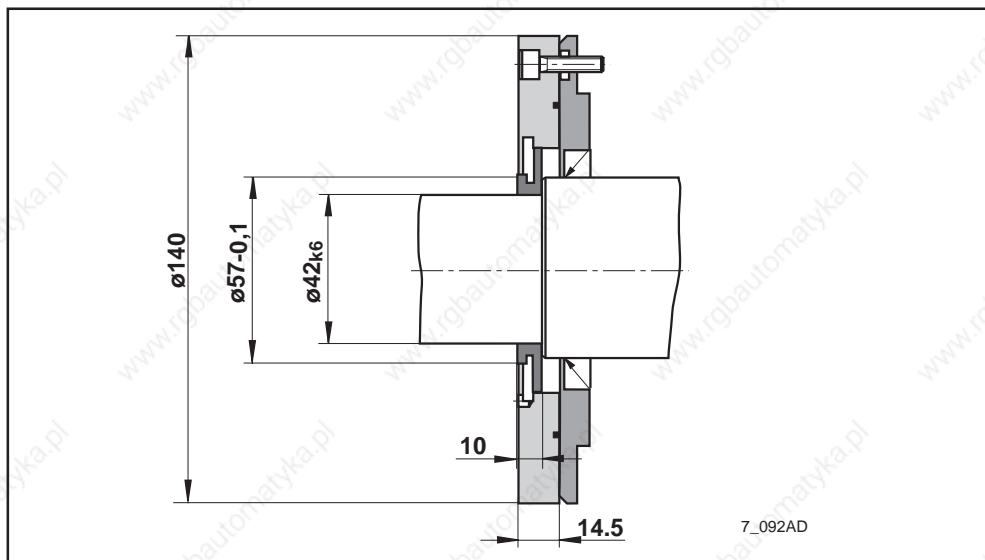

Fig. 7.9: 2AD134 with accessories mounted M02 2AD132/134 (Labyrinth seal)

Notes

8. Technical data 2AD160

8.1 Nominal data

Name	Symbol	Unit	2AD160		
			B	C	
Motor size			B	C	
Windings designation			BS	BS	DD
Nominal power ¹⁾	P_n	kW	30	37	46
Nennmoment ¹⁾	M_n	Nm	191	236	220
Motor nominal speed	n	min ⁻¹	1500		2000
Peak speed	n_{max}	min ⁻¹	6000		
Nominal current	I_n	A _{eff}	72	90	109
Nominal voltage	U_n	V _{eff}	305	299	316
Rotor moment of inertia ²⁾	J_M	kgm ²	0,174	0,229	
Thermal time constant	t_{th}	min	60	65	
Minimum conn. cross section EN 60204, sec. 1/02.86	A	mm ²	25	35	
Average noise level at a distance of 1 m (PWM=4kHz)	L_p	dB(A)	75±3		
Mass ³⁾	m	kg	205	240	
Ambient temperature		°C	0 ... 45		
Insulation classification DIN VDE 0530 Teil 1			F		
Vibration severity level ⁴⁾ DIN ISO 2373			R, S, S1		
¹⁾ Values determined as per DIN VDE 0530, section 1 When selecting AC main spindle motors, the specified nominal operating characteristics available must also be taken into consideration with operating modes S1, S2 and S6. ²⁾ Values without holding brake ³⁾ Values without holding brake, with blower ⁴⁾ Values see Fig. 2.7 "RMS oscillation speed"					

Fig. 8.1: Nominal data 2AD160

Permissible shaft load

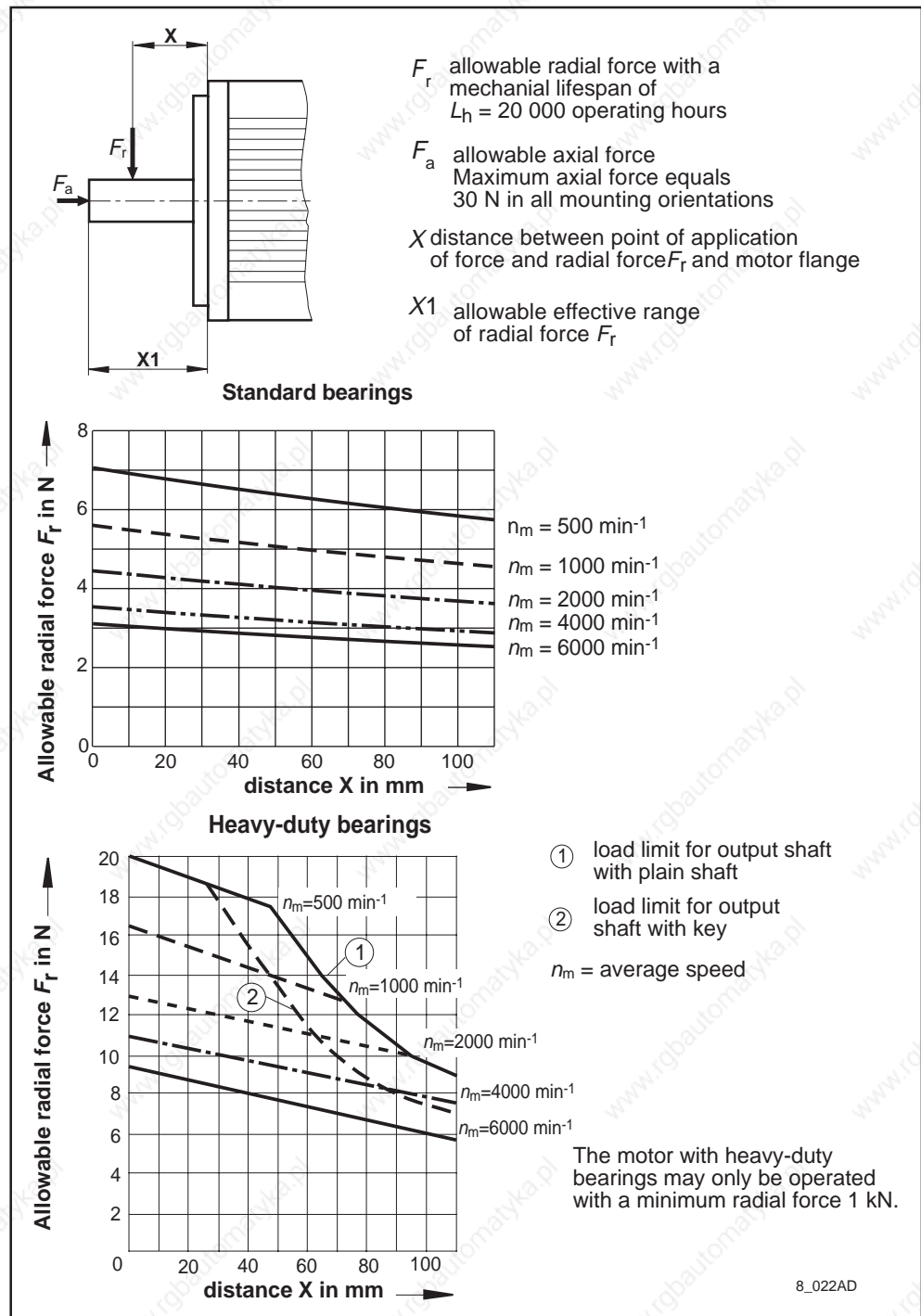

Fig. 8.2: Permissible shaft load 2AD160

Lubricant consumption

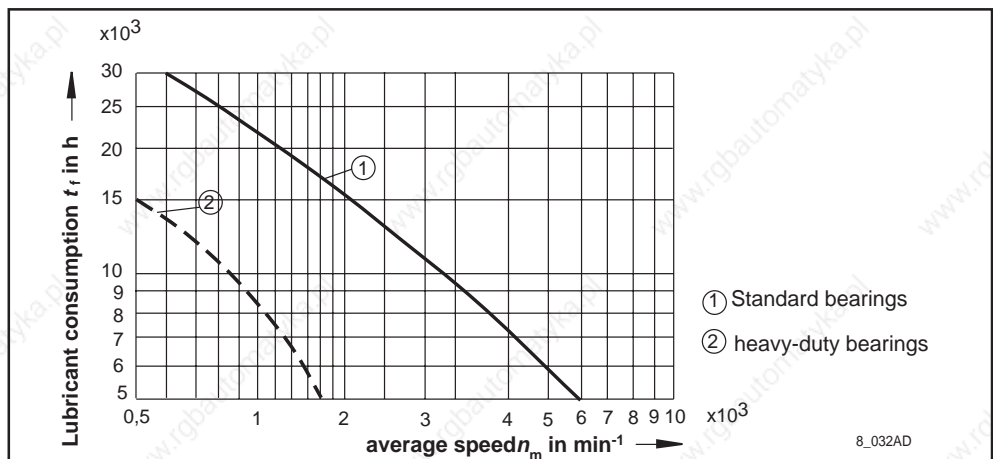

Fig. 8.3: Lubricant consumption duration 2AD160

8.2 Holding brake

Designation	Symbol	Unit	Version		
			electrically engaged	electrically released	electrically released heavy-duty
Operating principle			electrically engaged	electrically released	electrically released heavy-duty
Holding torque	M_h	Nm	130	70	240
Nominal terminal voltage	U_n	V	24±10%		
Nominal current	I_n	A	1,8	2,0	2,0
Moment of inertia	J_B	kgm ²	0,0065		0,0097
Maximum braking energy	W_{max}	Ws	40000		70000
Peak speed	n_{max}	min ⁻¹	6000 ¹⁾		
Release delay	t_l	ms	120	130	110
Clamp delay	t_k	ms	90	85	60
Mass	m	kg	5		11
<p>¹⁾ In the case of electrically-released holding brakes, the maximum speed is determined by the maximum braking energy, W_{max}, of the holding brake. It is calculated as follows:</p> $n_{max} = \sqrt{\frac{2 W_{max}}{J_M + J_B + J_C}} \cdot \frac{30}{3,14}$ <p> J_M rotor moment of inertia J_B moment of inertia of holding brake J_L moment of inertia of load (attachment to output shaft) </p>					

Fig. 8.4: Technical data of holding brake for 2AD160

8.3 Motor blower

Designation	Symbol	Unit	Version		
			Axial blower		Radial
Air current			B → A blowing recommended	A → B suction	B → A blowing
Power consumption	S_N	VA	220		330
Nominal voltage	U_N	V	3 x AC 400 V, 50/60 Hz 3 x AC 460 V, 60 Hz		
Average air volume	V	m ³ /h	1120		

Fig. 8.5: Technical data of motor blower for 2AD160

8. Technical data 2AD160

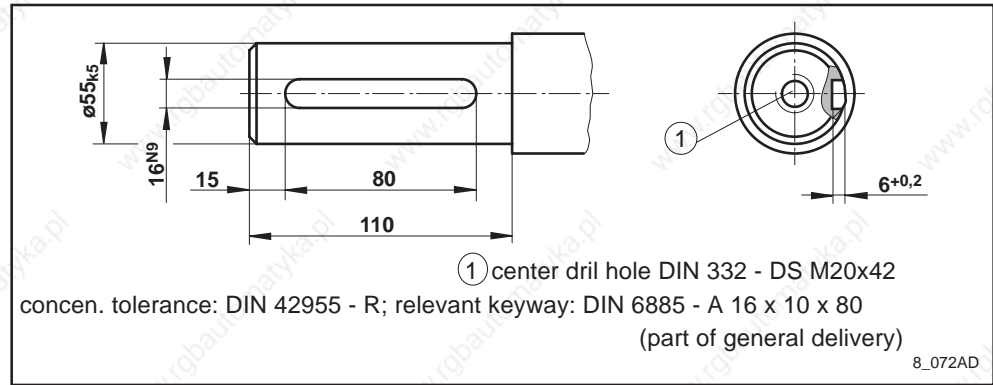

Fig. 8.7: Output shaft with key for 2AD160

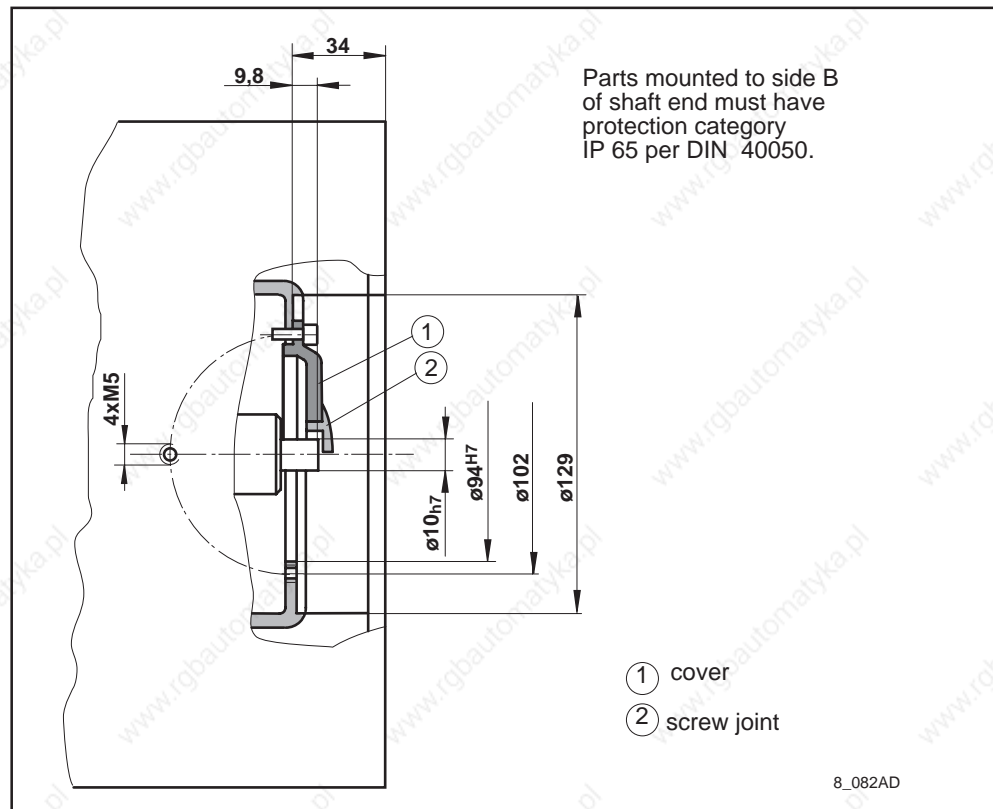

Fig. 8.8: Side-B shaft end 2AD160

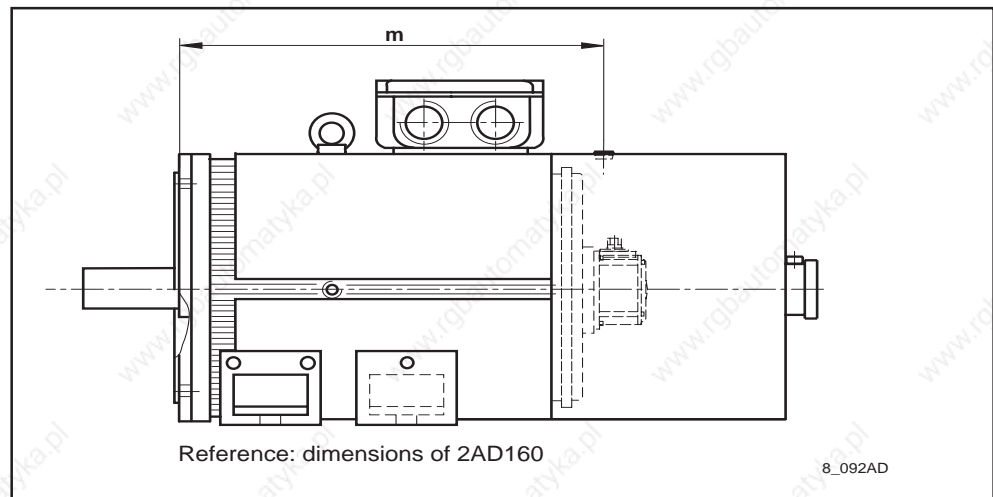

Fig. 8.9: 2AD160 with feedback types 6, 7

8. Technical data 2AD160

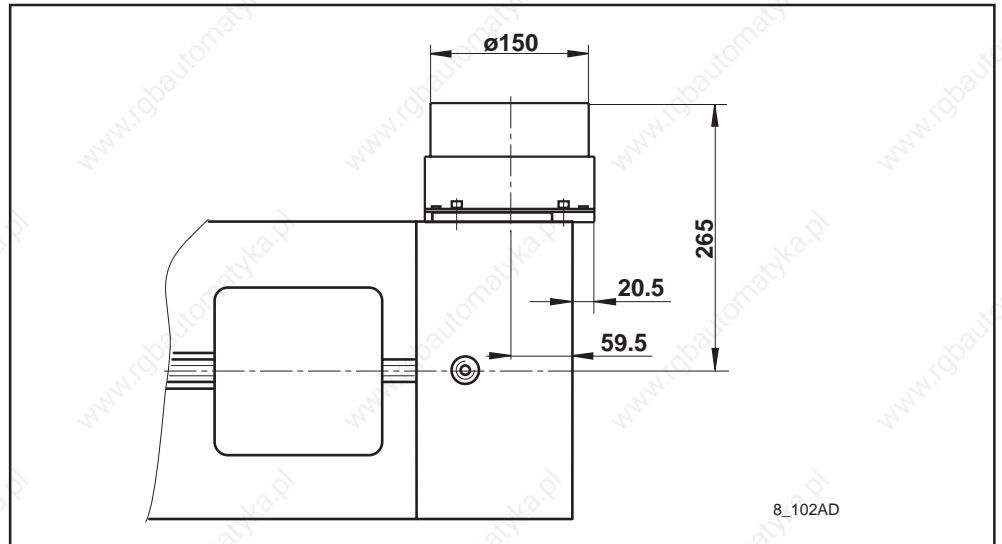

Fig. 8.10: 2AD160 with accessories mounted M01 2AD160/164 (Blower support base)

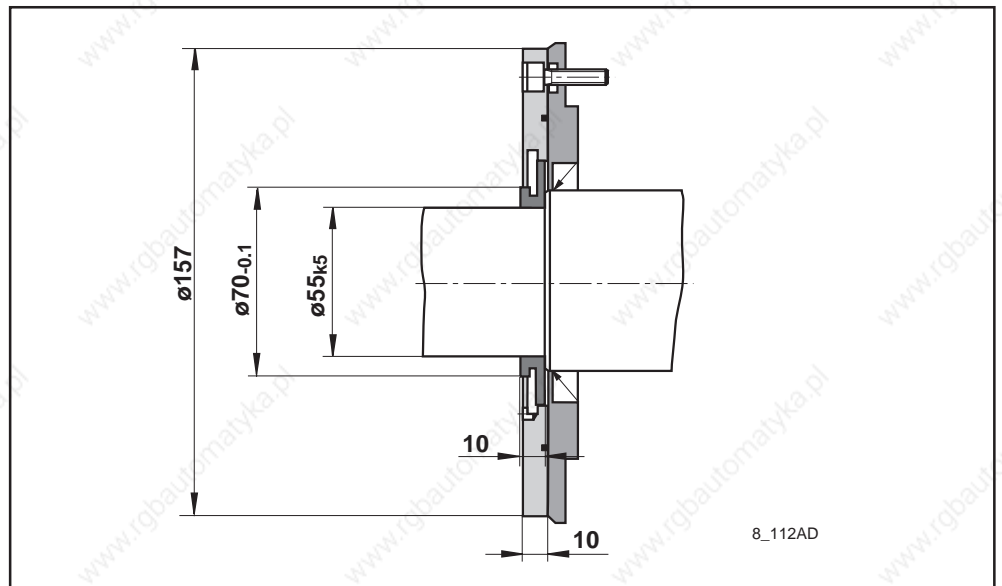

Fig. 8.11: 2AD160 with accessories mounted M02 2AD160/164 (Labyrinth seal)

8.5 Type codes

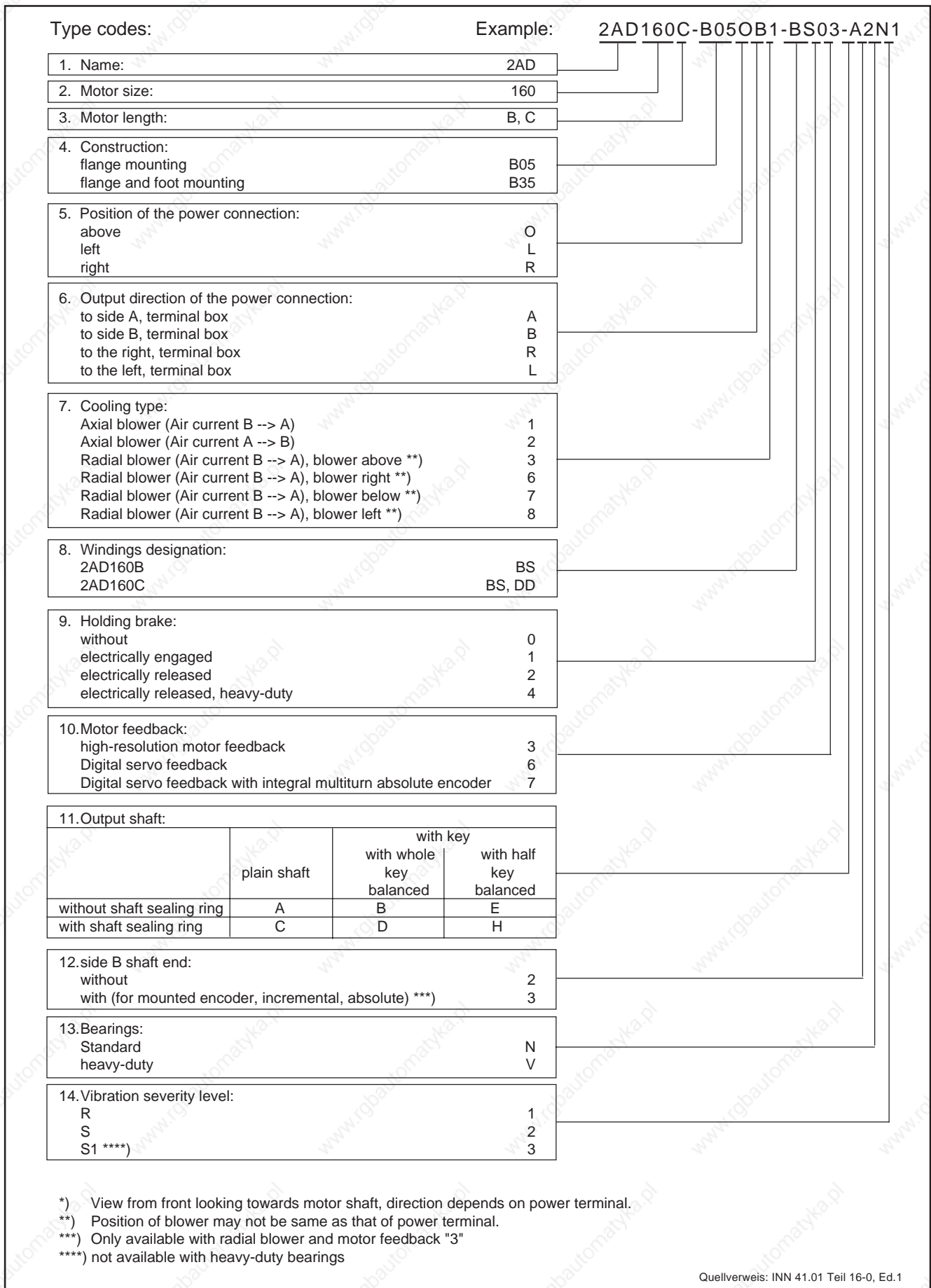

Fig. 8.12: Type codes 2AD160

9. Technical data 2AD164

9.1 Nominal data

Name	Symbol	Unit	2AD164	
			B	C
Motor size			B	C
Windings ID letters			DS	ES
Nominal power ¹⁾	P_n	kW	35	44
Nominal torque ¹⁾	M_n	Nm	223	280
Motor nominal speed	n	min^{-1}	1500	
Maximum speed	n_{max}	min^{-1}	6000	
Nominal current	I_n	A_{eff}	55,6	74
Nominal voltage	U_n	V_{eff}	470	453
Rotor moment of inertia ²⁾	J_M	kgm^2	0,174	0,229
Thermal time constant	t_{th}	min	60	65
Minimum conn. cross section of INDRAMAT cables (INK...)	A	mm^2	16	25
Average sound pressure at 1m (PWM=4kHz)	L_p	dB(A)	75±3	
Mass ³⁾	m	kg	205	240
Ambient temperature		°C	0 ... 45	
Insulation classification DIN VDE 0530 section 1			F	
Vibration severity level ⁴⁾ DIN ISO 2373			R, S, S1	
¹⁾ Values determined per DIN VDE 0530 section 1 Characteristics are available when selecting AC main spindle motors at the specified nominal ratings taking operating modes S1, S2 and S6 into account. ²⁾ Values without holding brakes ³⁾ Values without holding brakes, with blower ⁴⁾ For values see Fig. 2.7 "RMS vibration speed"				

Fig. 9.1: Nominal data 2AD164

Permissible shaft load

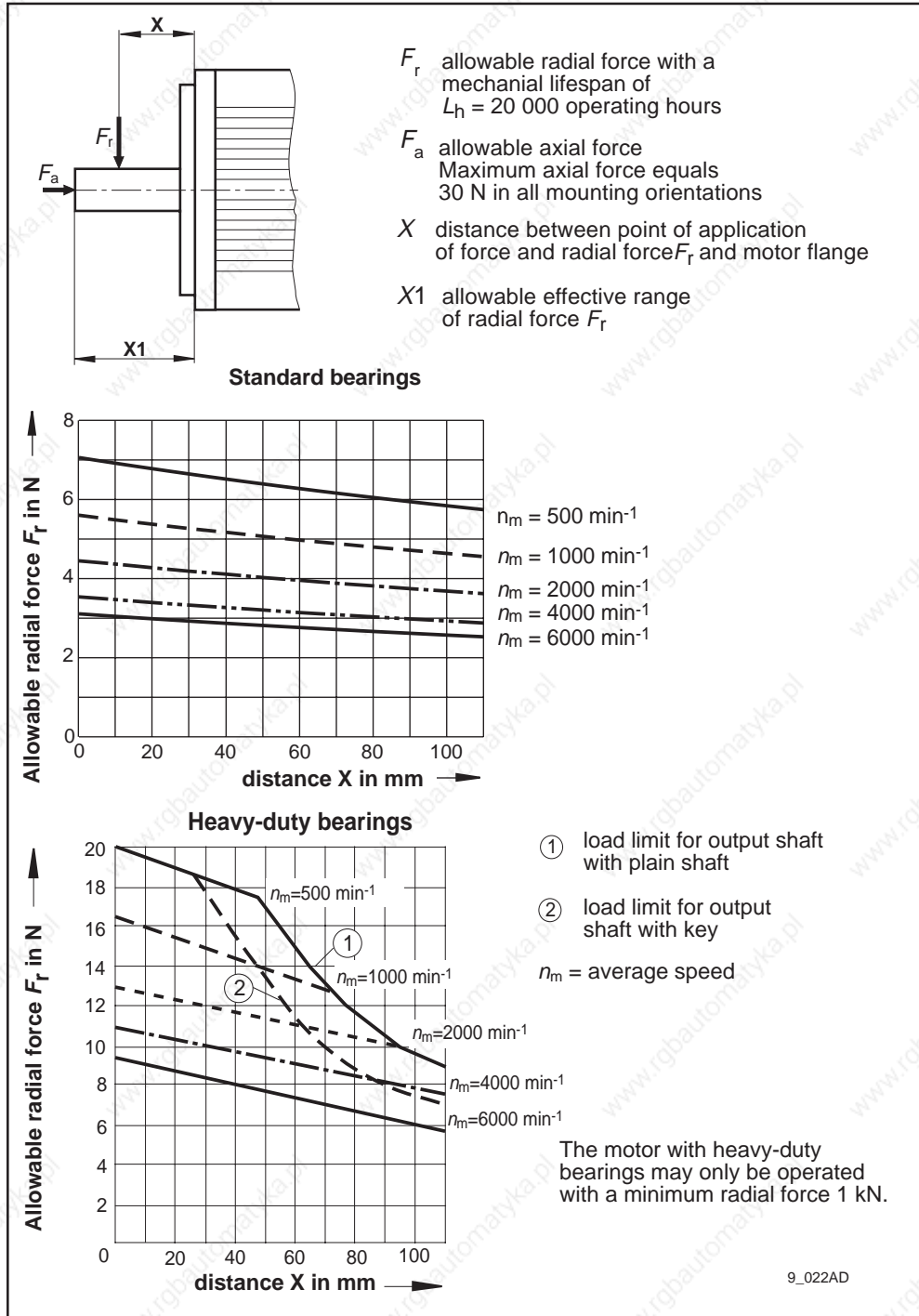

Fig. 9.2: Permissible shaft load 2AD164

Lubricant consumption

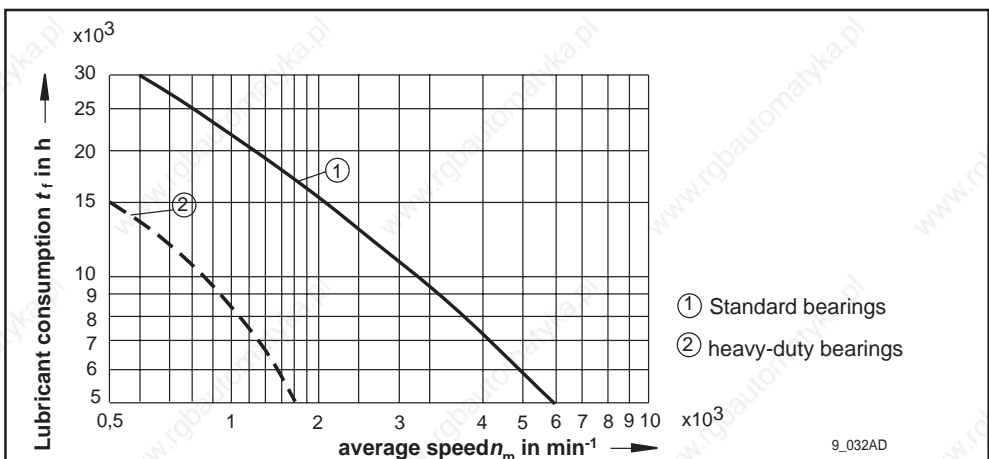

Fig. 9.3: Lubricant consumption 2AD164

9.2 Holding brake

Designation	Symbol	Unit	Design		
			electrical clamp	electrical release	electrical release heavy-duty
Functional principle			electrical clamp	electrical release	electrical release heavy-duty
Holding torque	M_h	Nm	130	70	240
Nominal conn. voltage	U_n	V	24±10%		
Nominal current	I_n	A	1,8	2,0	2,0
Moment of inertia	J_B	kgm ²	0,0065		0,0097
Max. decel energy	W_{max}	Ws	40000		70000
Maximum speed	n_{max}	min ⁻¹	6000 ¹⁾		
Release delay	t_l	ms	120	130	110
Clamp delay	t_k	ms	90	85	60
Mass	m	kg	5		11
<p>¹⁾ With electrically released holding brake the maximum speed is determined by maximum decel energy W_{max} of the holding brake. It is computed:</p> $n_{max} = \sqrt{\frac{2 W_{max}}{J_M + J_B + J_C}} \cdot \frac{30}{3,14}$ <p> J_M rotor moment of inertia J_B moment of inertia of holding brake J_L moment of inertia of load (attachment mounted to output shaft) </p>					

Fig. 9.4: Technical data of holding brake on 2AD164

9.3 Motor blower

Designation	Symbol	Unit	Design		
			Axial blower		Radial
Air current			B → A blowing (recommended)	A → B suction	B → A blowing
Power consumption	S_N	VA	220		330
Nominal voltage	U_N	V	3 x AC 400 V, 50/60 Hz 3 x AC 460 V, 60 Hz		
Average air volume	V	m ³ /h	1120		

Fig. 9.5: Technical data of motor blower on 2AD164

9. Technical data 2AD164

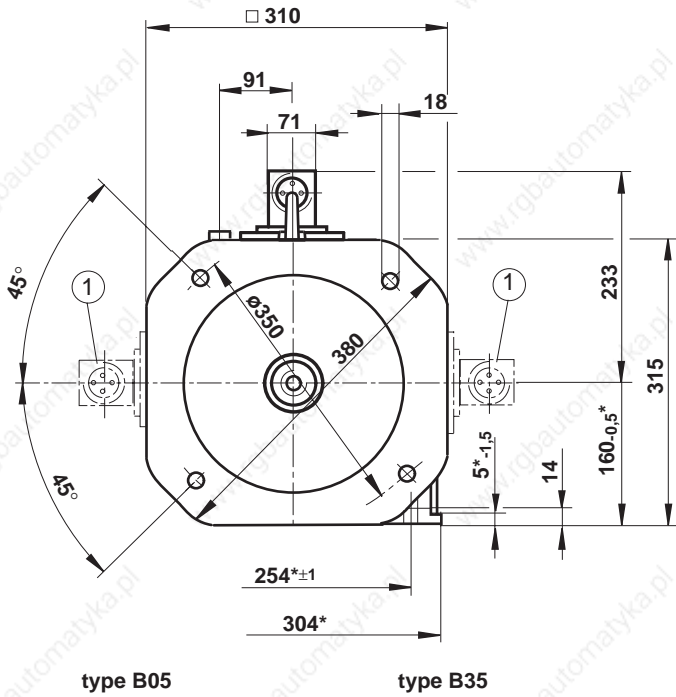

Dim.:	2AD164B	2AD164C
a*	254	354
w/o hold. brake	751	841
k with hold. brake	813	903
w/ hold. brake heavy-duty	881	971
l	460,5	550,5
w/o hold. brake	598	688
m with hold. brake	660	750
w/ hold. brake heavy-duty	728	818
q	280	330

* with foot mounting only, B35

- ① power connection, plug-in connector
- ③ plain shaft end concn. tolerance DIN 42955 - R on front center drill hole DIN 332 - DS M20x42
- ④ flange dimensions per DIN 42948
- ⑤ ring screw M20 - DIN 580
- ⑥ add. thread M20 for ring screw second thread opposite
- ⑦ air flow A → B
- ⑧ air flow B → A
- ⑨ Motor feedback connection type (flange socket), arranged per position of power connection
- ⑩ axial blower
- ⑪ Radial blower; position of radial blower may not be the same as power connection
- ⑫ Motor blower connection: plug-in connector
- ⑬ Mounting distance (minimum for pulling in ventilating air)
- ⑮ air baffle

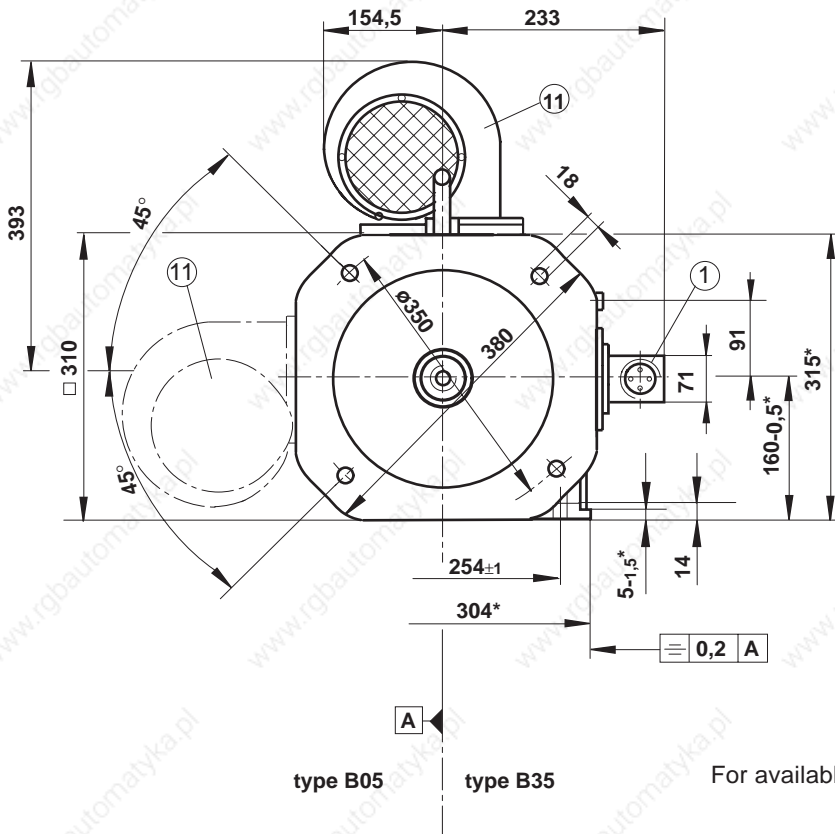

Dim.	2AD164B	2AD164C
a*	254	344
w/o hold. brake	637	727
k with hold. brake	699	789
w/ hold. brake heavy-duty	767	857
l	460,5	550,5
w/o hold. brake	598	688
m with hold. brake	660	750
w/ hold. brake heavy-duty	728	718
q	280	330

* Foot mounting only, B35

For available version see Fig. 9.10 - type codes

Fig. 9.6: Dimensions for 2AD164

9. Technical data 2AD164

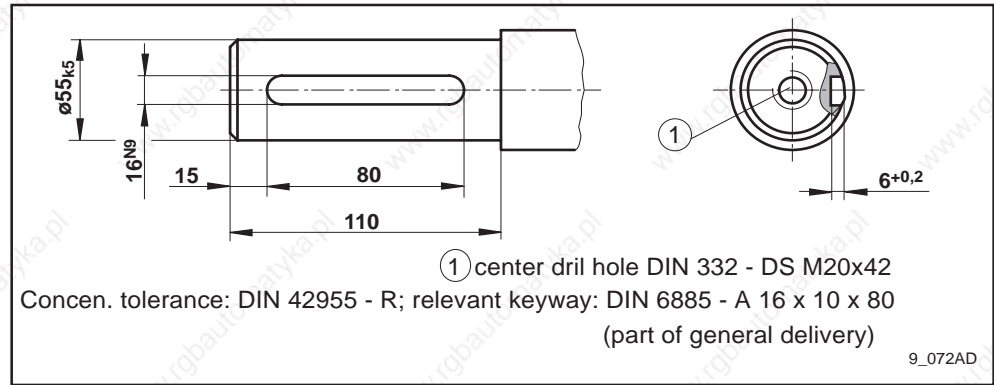

Fig. 9.7: Output shaft with key 2AD164

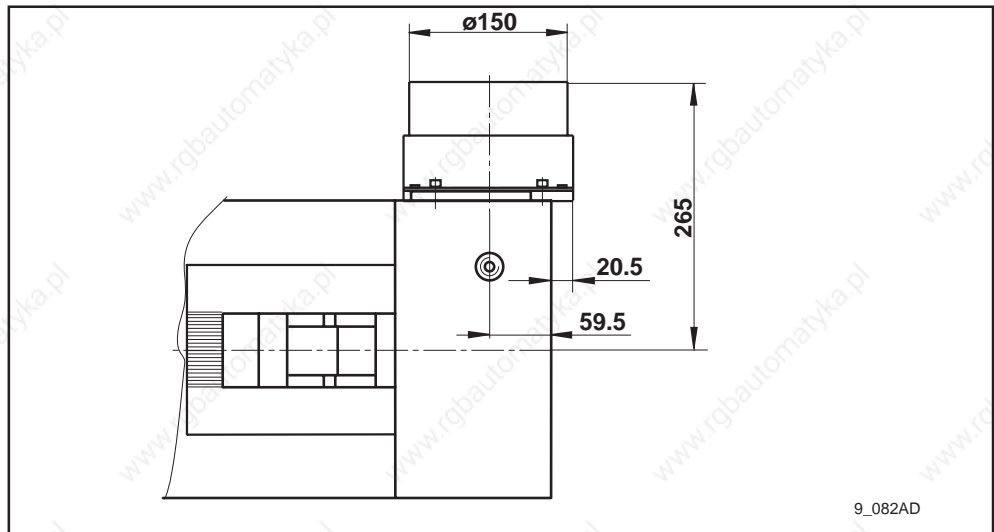

Fig. 9.8: 2AD164 with mounted accessories - M01 2AD160/164 (blower base)

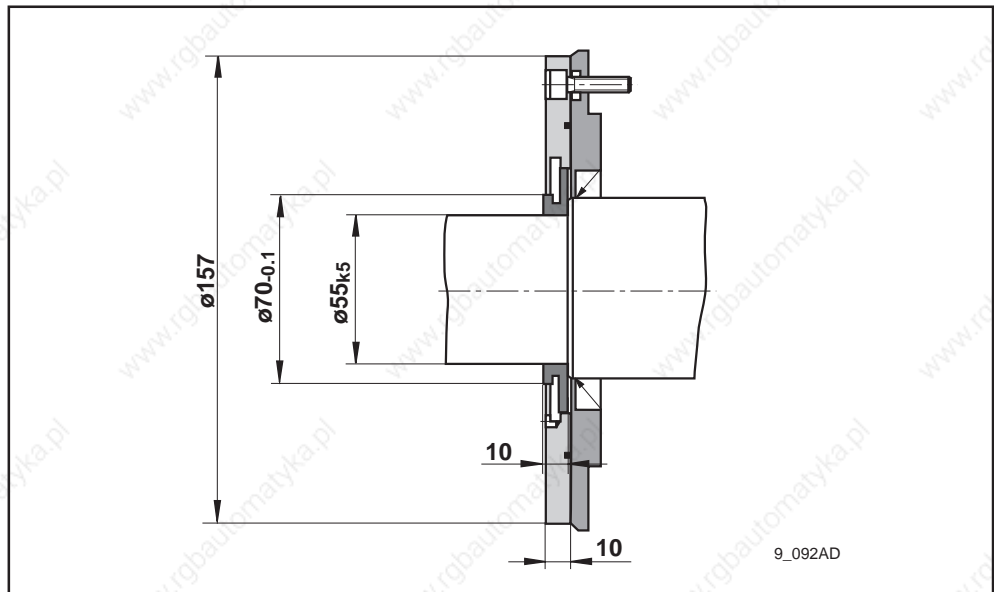

Fig. 9.9: 2AD164 with mounted accessories - M02 2AD160/164 (labyrinth seal)

9.5 Type codes

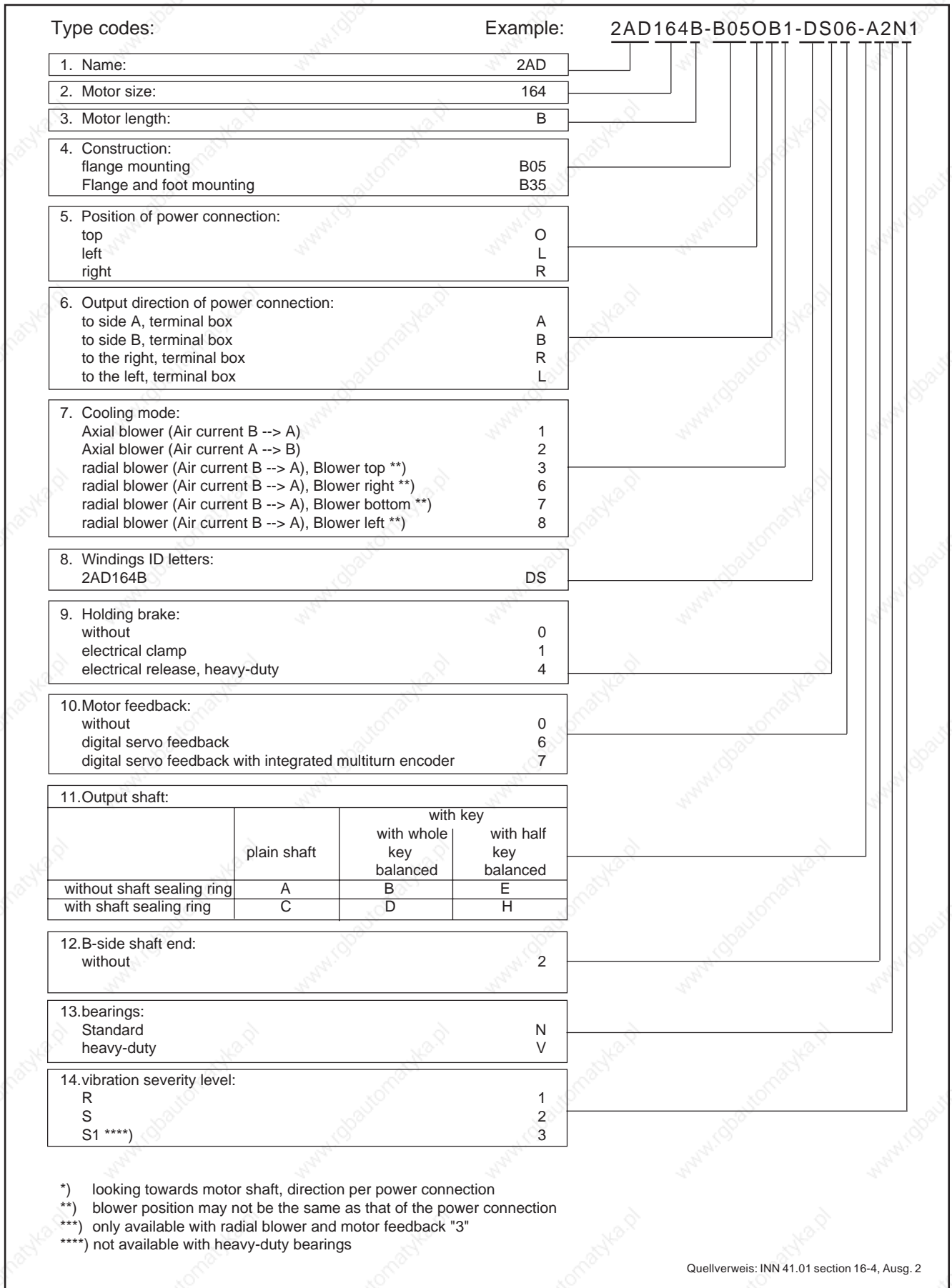

Fig. 9.10: Type codes 2AD164

Notes

10. Technical data 2AD180

10.1 Nominal data

Name	Symbol	Unit	2AD180		
			C	AS	D
Motor size			C	AS	D
Windings ID letters			BS	AS	BS
Nominal power ¹⁾	P_n	kW	52	49	63
Nominal torque ¹⁾	M_n	Nm	331	425	401
Motor nominal speed	n	min ⁻¹	1500	1100	1500
Maximum speed	n_{max}	min ⁻¹	6000		
Nominal current	I_n	A _{eff}	110		133
Nominal voltage	U_n	V _{eff}	351	322	365
Rotor moment of inertia ²⁾	J_M	kgm ²	0,373	0,45	
Thermal time constant	t_{th}	min	70	75	
Minimum conn. cross section EN 60204 section 1/02.86	A	mm ²	35		50
Average noise level at 1m (PWM=4kHz)	L_p	dB(A)	80±3		
Mass ³⁾	m	kg	310	402	
Ambient temperature		°C	0 ... 45		
Insulation classification DIN VDE 0530 section 1			F		
Vibration severity level ⁴⁾ DIN ISO 2373			R, S, S1		
¹⁾ Values determined per DIN VDE 0530 section 1 For the selection of an AC main spindle motor, curves are available for the specified nominal powers which take operating modes S1, S2 and S6 into consideration. ²⁾ Values without holding brakes ³⁾ Values without holding brakes, with blower ⁴⁾ For values see Fig. 2.7 "RMS vibration speed"					

Fig. 10.1: Nominal data 2AD180

Permissible shaft load

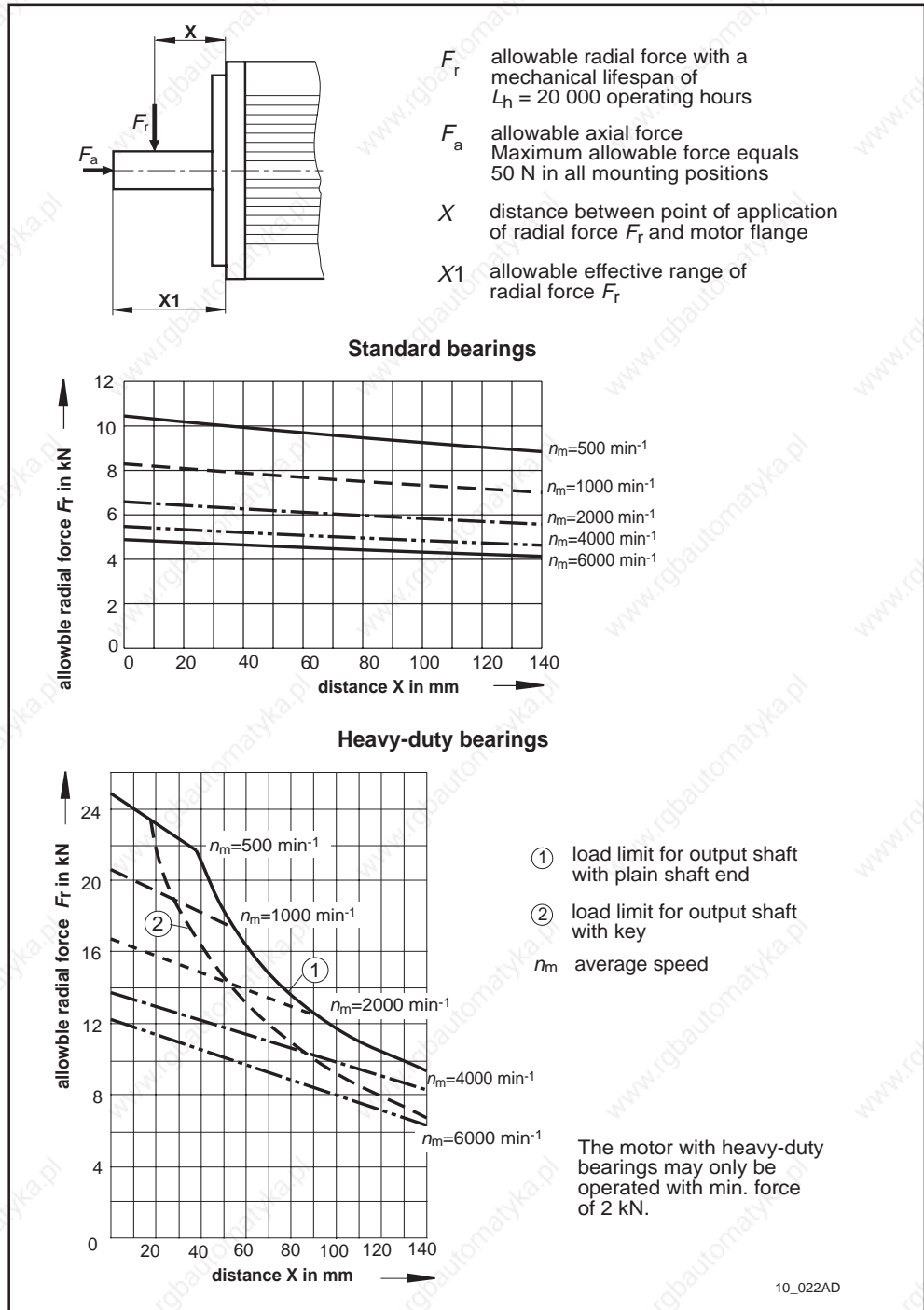

Fig. 10.2: Permissible shaft load 2AD180

Lubricant consumption

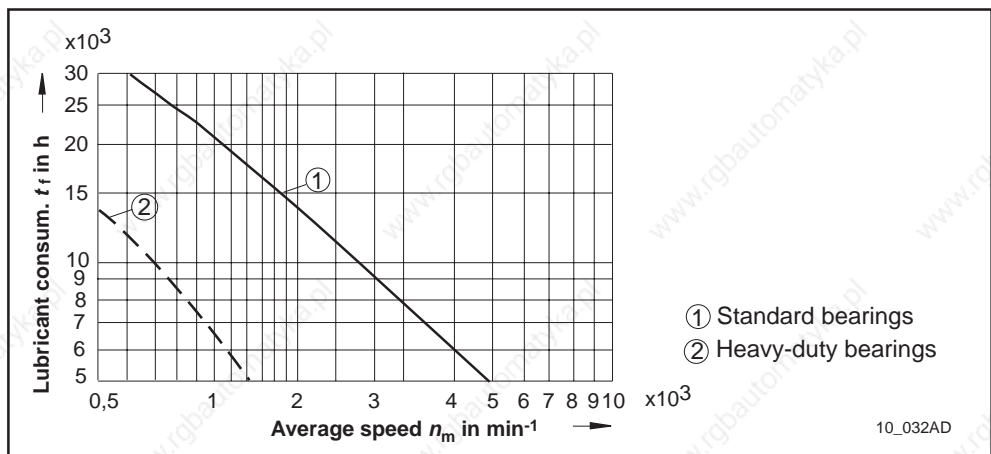

Fig. 10.3: Lubricant consumption 2AD180

10.2 Holding brake

(Only possible with motor length "C".)

Designation	Symbol	Unit	Design	
			electrical clamp	electrical release
Functional principle			electrical clamp	electrical release
Holding torque	M_h	Nm	300	200
Nominal conn. voltage	U_n	V	24±10%	
Nominal current	I_n	A	2	
Moment of inertia	J_B	kgm ²	0,0097	
Max. decel energy	W_{max}	Ws	70000Maximum	
Speed	n_{max}	min ⁻¹	6000 ¹⁾	
Release delay	t_l	ms	160	110
Clamp delay	t_k	ms	120	60
Mass	m	kg	11	
<p>1) With an electrically released holding brake, the peak speed of is determined by the maximum decel energy W_{max} of the holding brake. It is computed:</p> $n_{max} = \sqrt{\frac{2 W_{max}}{J_M + J_B + J_C}} \cdot \frac{30}{3,14}$ <p> J_M rotor moment of inertia J_B moment of inertia of holding brake J_L moment of inertia of load reduced (attachment mounted to output shaft) </p>				

Fig. 10.4: Technical data of holding brake on 2AD180

10.3 Motor blower

Designation	Symbol	Unit	Design		
			axial blower		radial blower
Air current			B → A blowing (recommended)	A → B suction	A → B suction
Power consumption	S_N	VA	220		330
Nominal voltage	U_N	V	3 x AC, 400V 50/60Hz 3 x AC, 460V 60Hz		
Average air volume	V	m ³ /h	1950		

Fig. 10.5: Technical data of motor blower on 2AD180

10.4 Dimensions

Motor with Axial blower and feedback types 3, B35

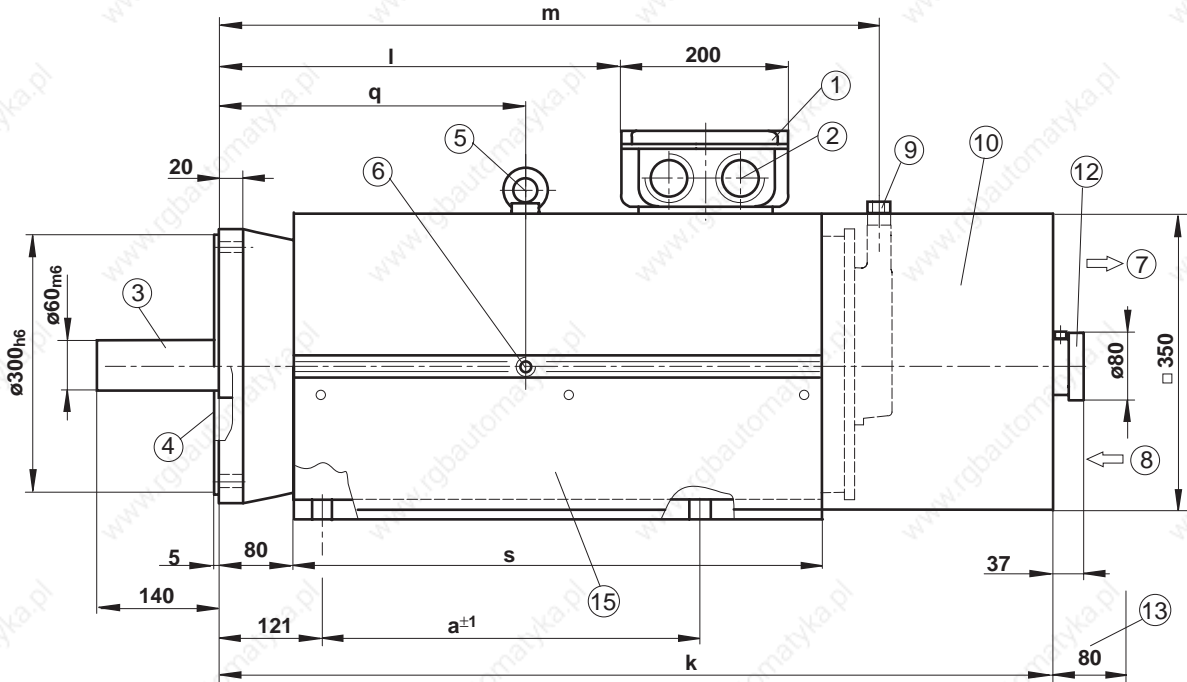

Motor with radial blower and feedback type 3, B35

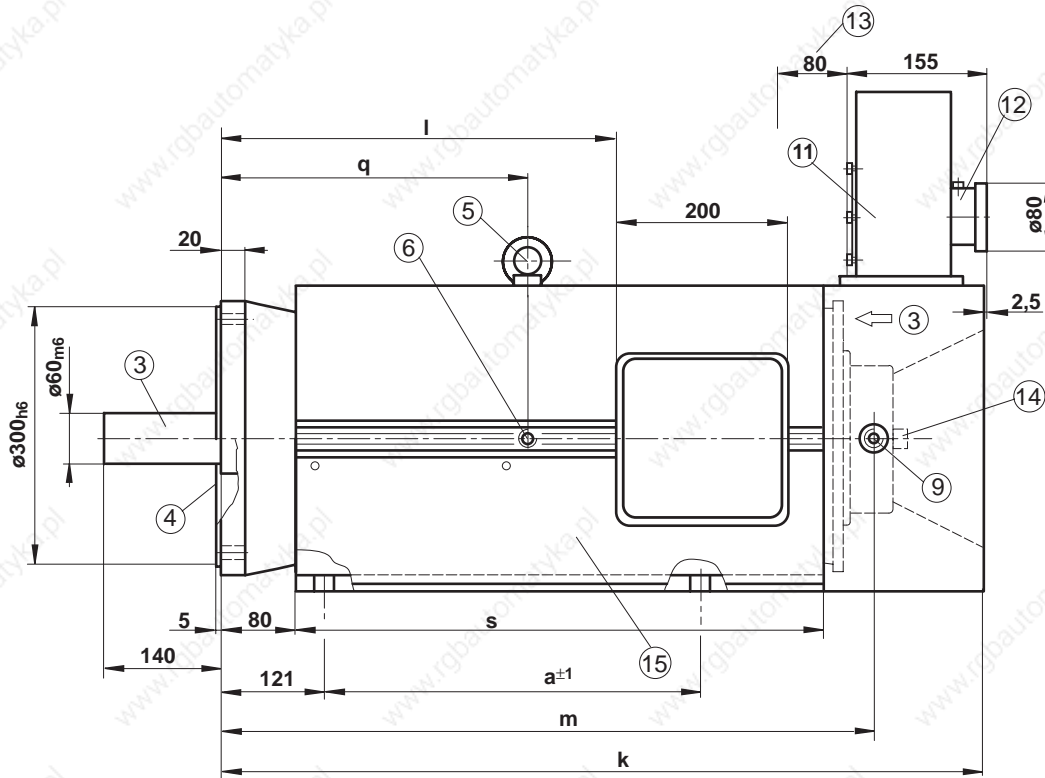

Tolerances

Dim. upto	6	30	120	400	1000	2000
Tolerance	±0,1	±0,2	±0,3	±0,5	±0,8	±1,2

10_0618A

10. Technical data 2AD180

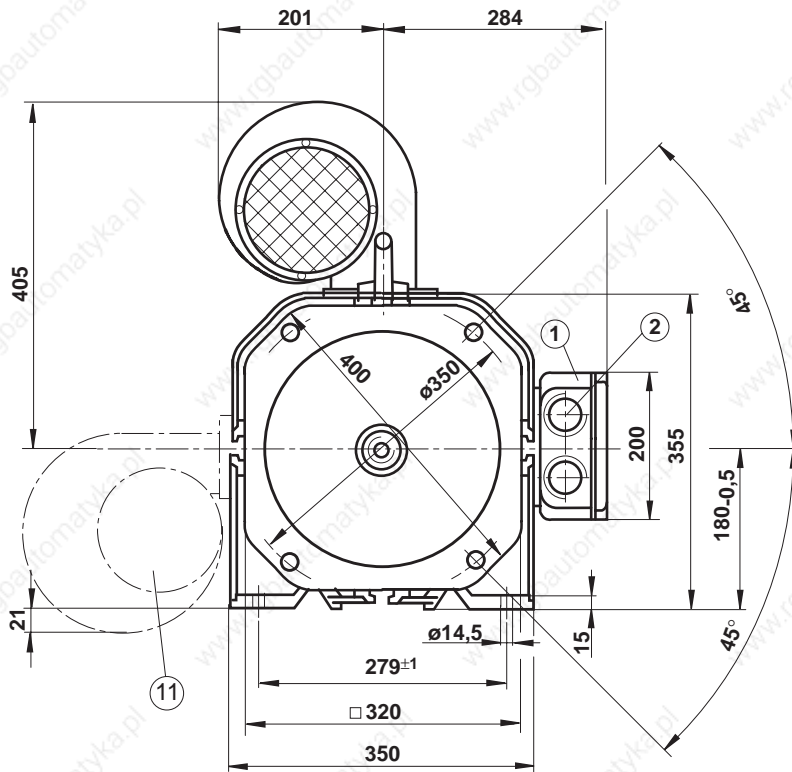
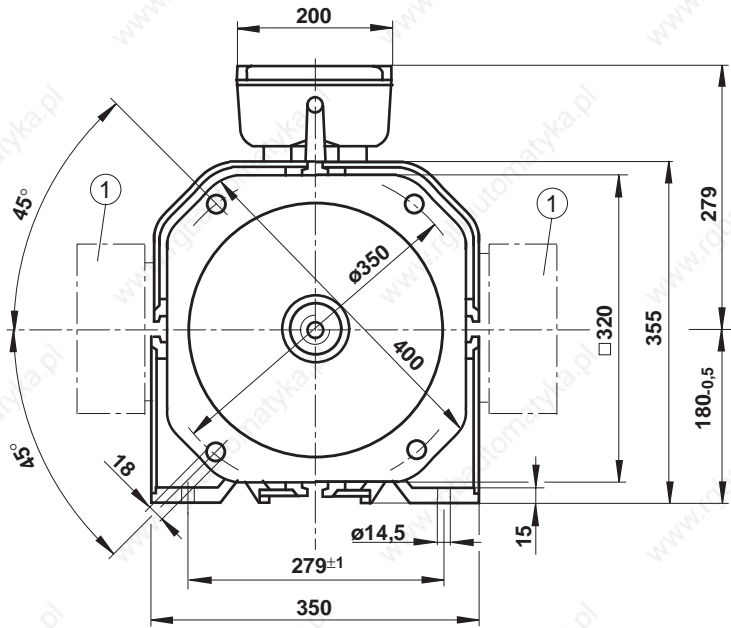

Dim.:	2AD180C	2AD180D
a	430	540
k	944	1054
l	464	574
m	743,5	853,5
q	360	415
s	599	709

- ① power connection; arrangement selectable, can be turned by 90°, in terms of output direction of power connection
- ② cable output: PG 42
- ③ plain shaft end concentricity tolerance DIN 42955 -R; center drill hole on front DIN 332 DS M20x42
- ④ flange dimensions per DIN42948
- ⑤ ring screws M20 - DIN 580
- ⑥ add. threads M20 for ring screws; second thread opposite
- ⑦ air flow A → B
- ⑧ air flow B → A
- ⑨ Motor feedback conn. type 3 (flanged socket), allocation per position of power connection
- ⑩ Axial blower
- ⑪ Radial blower arrangement selectable; pos. if radial blower may not be same as that of power connection.
- ⑫ Motor blower connection terminal box with cable threaded joint
- ⑬ Mounting distance (min. clearance for taking in air for cooling).
- ⑭ B-side shaft end dimensions, see Fig. 10.8
- ⑮ Air baffle

Dim.:	2AD180C	2AD180D
a	430	540
k	889	999
l	464	574
m	743,5	853,5
q	360	415
s	599	709

Available designs, see Fig. 10.12 - Type codes

10_0618B

Fig. 10.6: Dimensions for 2AD180

10. Technical data 2AD180

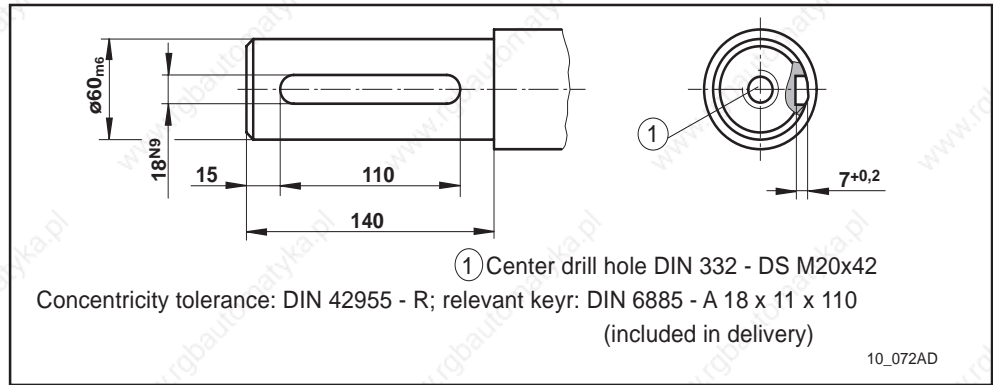

Fig. 10.7: Output shaft with key 2AD180

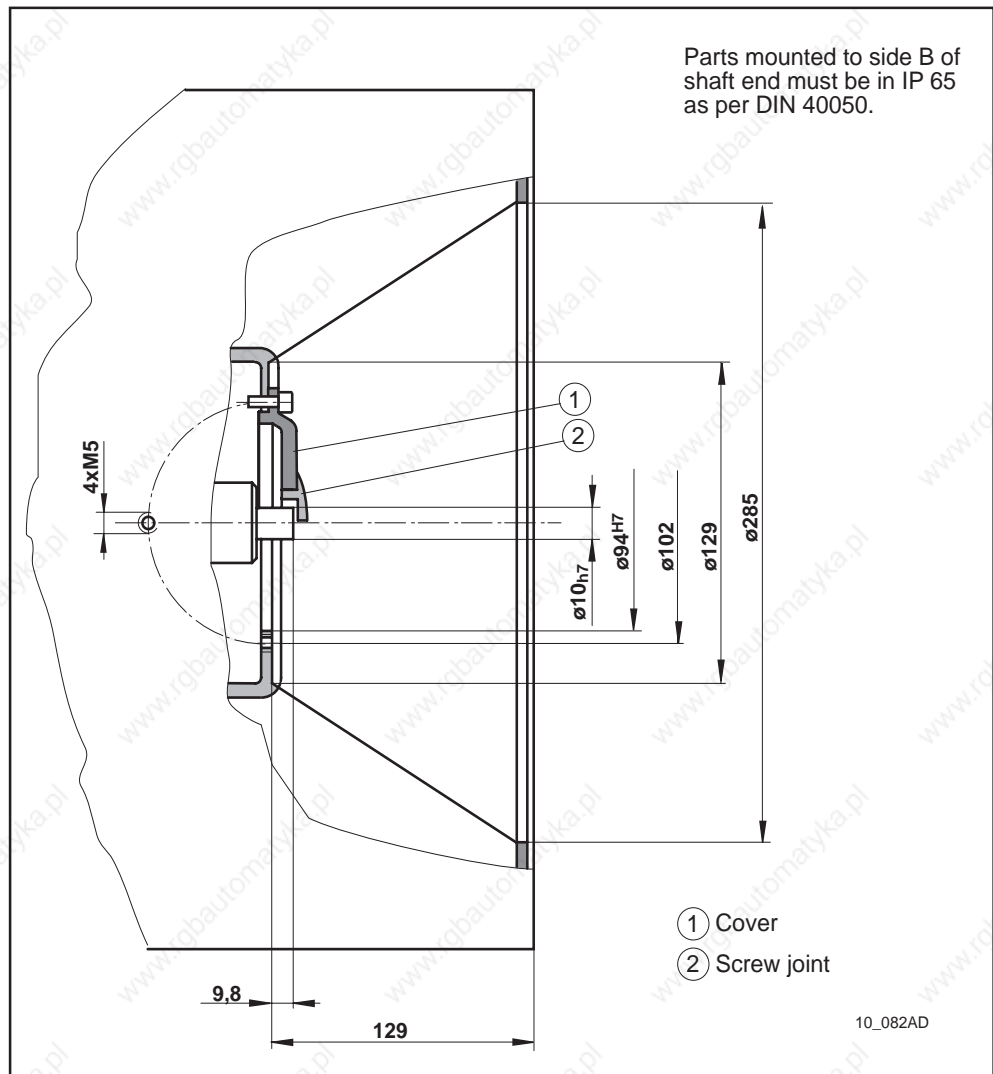

Fig. 10.8: B-side shaft end 2AD180

10. Technical data 2AD180

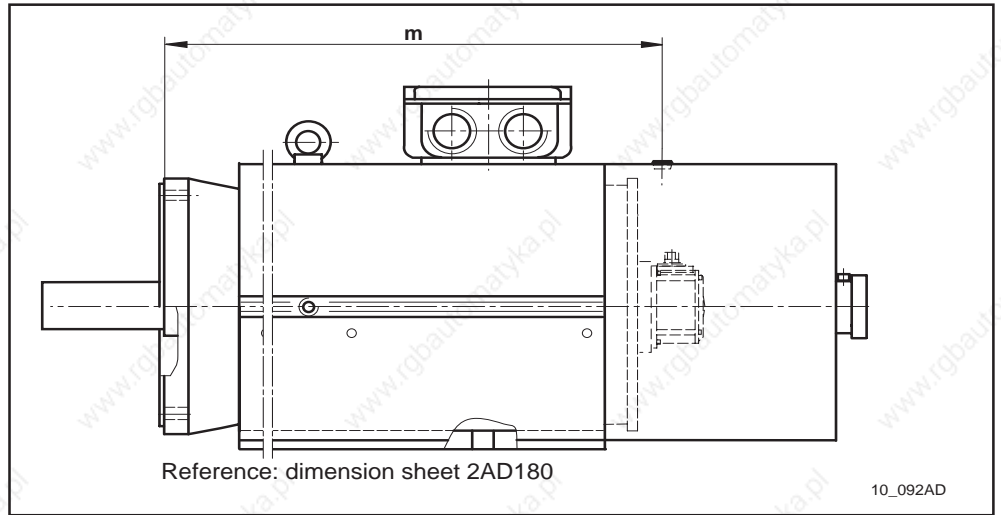

Fig. 10.9.: 2AD180 with feedback types 6, 7

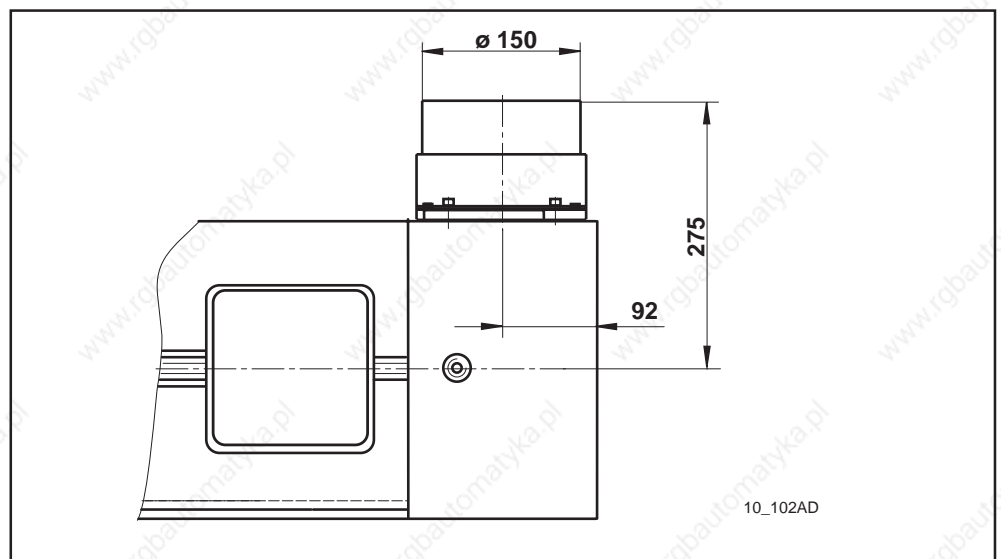

Fig. 10.10.: 2AD180 with mounted accessories - M01 2AD180 (blower base)

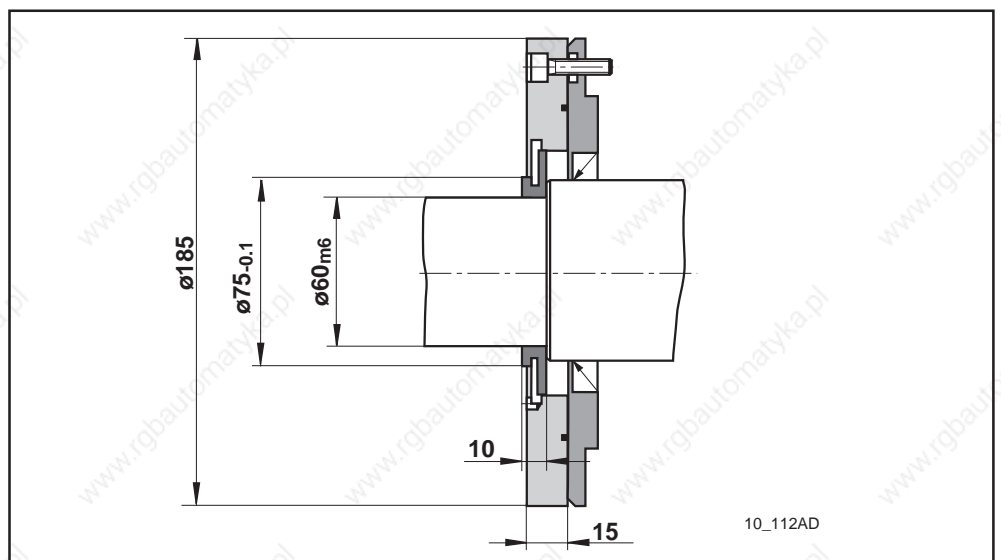

Fig. 10.11.: 2AD180 with mounted accessories - M02 2AD180 (labyrinth seal)

10.5 Type codes

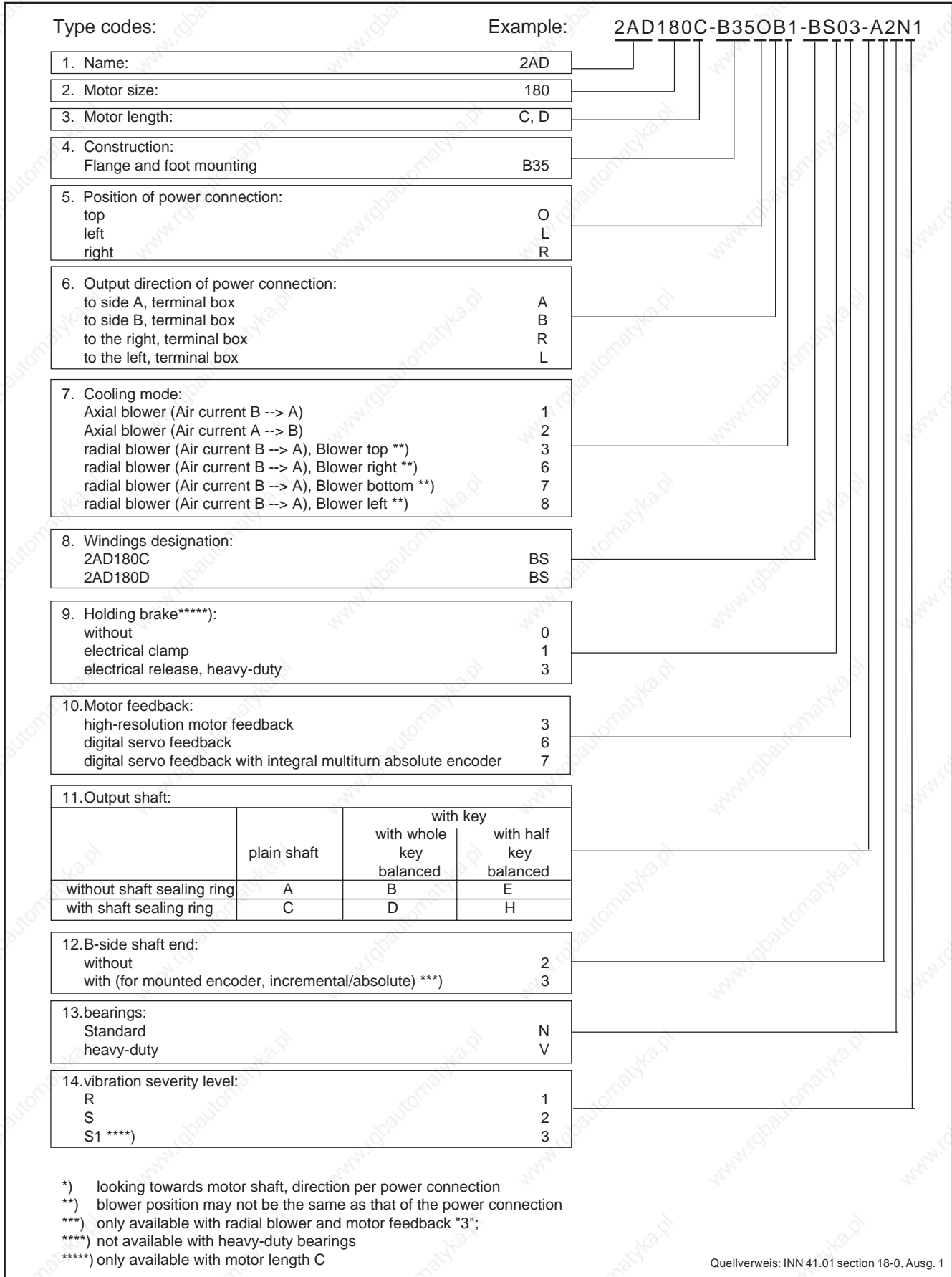

Fig. 10.12: Type codes 2AD180

11. Technical data 2AD200

11.1 Nominal data

Name	Symbol	Unit	2AD200
Motor size			C
Windings ID letters			AS
Nominal power ¹⁾	P_n	kW	79
Nominal torque ¹⁾	M_n	Nm	503
Motor nominal speed	n	min ⁻¹	1500
Maximum speed	n_{max}	min ⁻¹	5000
Nominal current	I_n	A _{eff}	186
Nominal voltage	U_n	V _{eff}	325
Rotor moment of inertia ²⁾	J_M	kgm ²	0,66
Thermal time constant	t_{th}	min	
Minimum conn. cross section EN 60204 section 1/02.86	A	mm ²	or 2 x 25 1 x 70
Average noise level at 1m (PWM=4kHz)	L_p	dB(A)	77±3
Mass ³⁾	m	kg	450
Ambient temperature		°C	0 ... 45
Insulation classification DIN VDE 0530 section 1			F
Vibration severity level ⁴⁾ DIN ISO 2373			R, S, S1
<p>¹⁾ Values determined per DIN VDE 0530 section 1 For the selection of an AC main spindle motor, curves are available for the specified nominal powers which take operating modes S1, S2 and S6 into consideration.</p> <p>²⁾ Values without holding brakes</p> <p>³⁾ Values without holding brakes, with blower</p> <p>⁴⁾ For values see Fig. 2.7 "RMS vibration speed"</p>			

Fig. 11.1: Nominal data 2AD200

Permissible shaft load

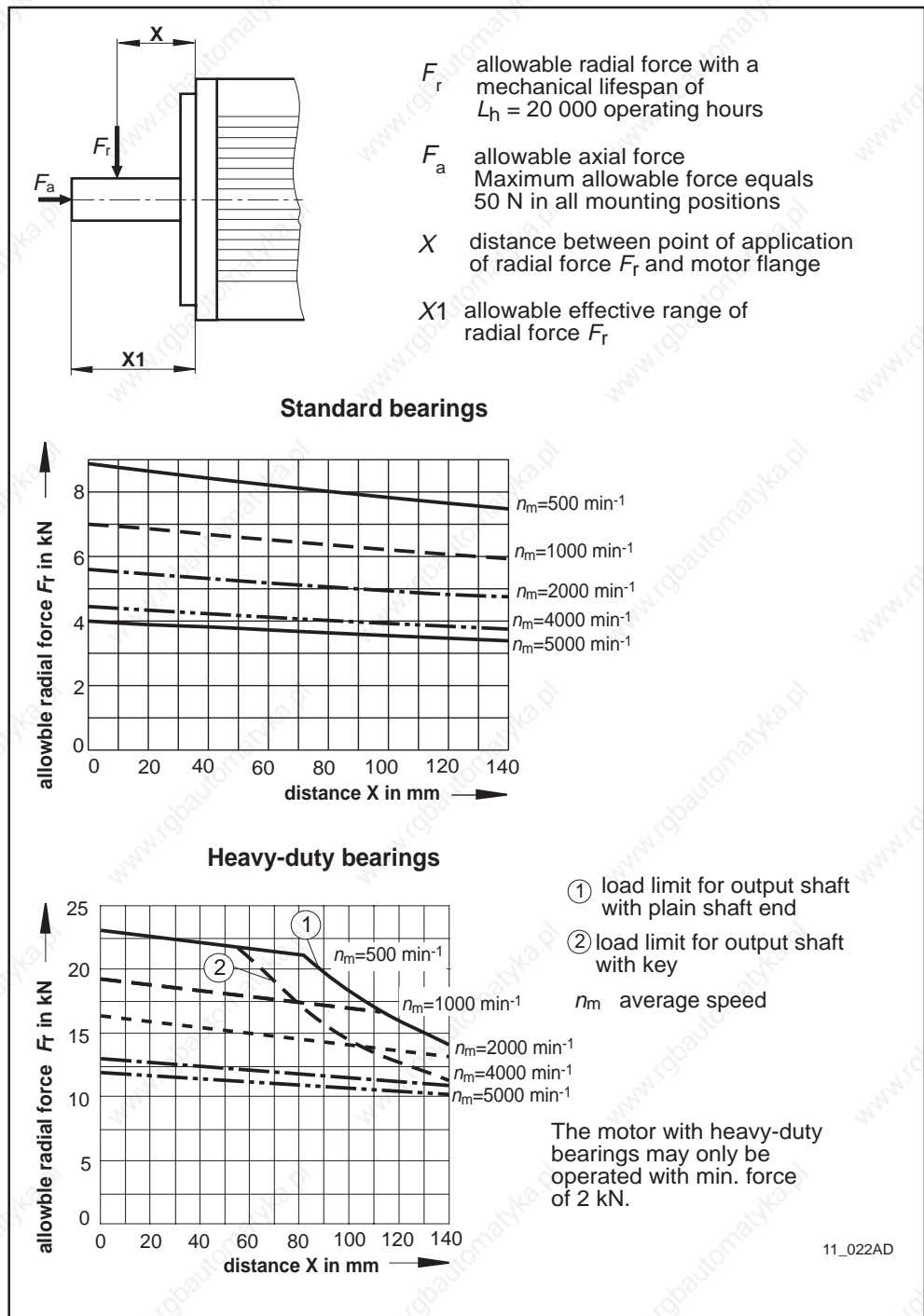

Fig. 11.2: Permissible shaft load 2AD200

Lubricant consumption

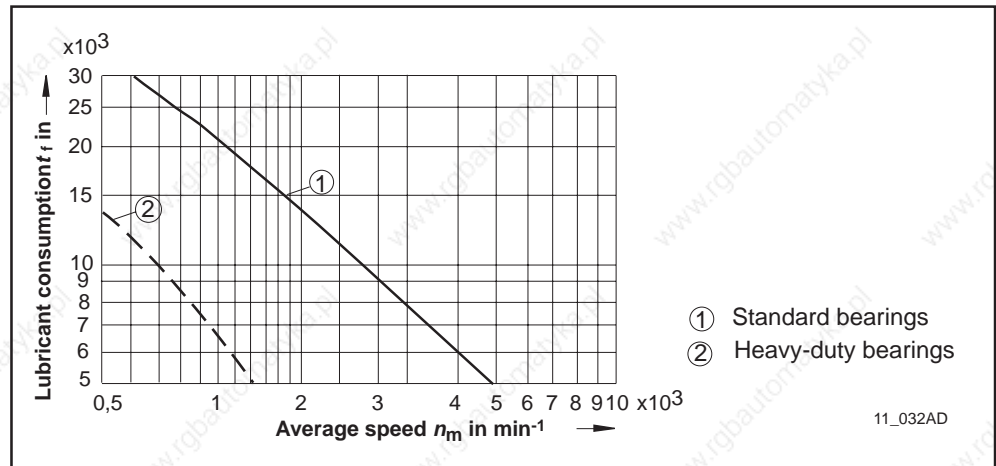

Fig. 11.3: Lubricant consumption 2AD200

11.2 Motor blower

Designation	Symbol	Unit	Design		
			axial blower	radial blower	
Air current			B → A blowing (recommended)	A → B suction	B → A blowing
Power consumption	S_N	VA	600		340
Nominal voltage	U_N	V	3 x AC, 400V, 50/60Hz 3 x AC, 460V, 60Hz		
Average air volume	V	m ³ /h	2500		

Fig. 11.4: Technical data of motor blower on 2AD200

11.3 Dimensions

Motor with axial blower and feedback types 3, B35

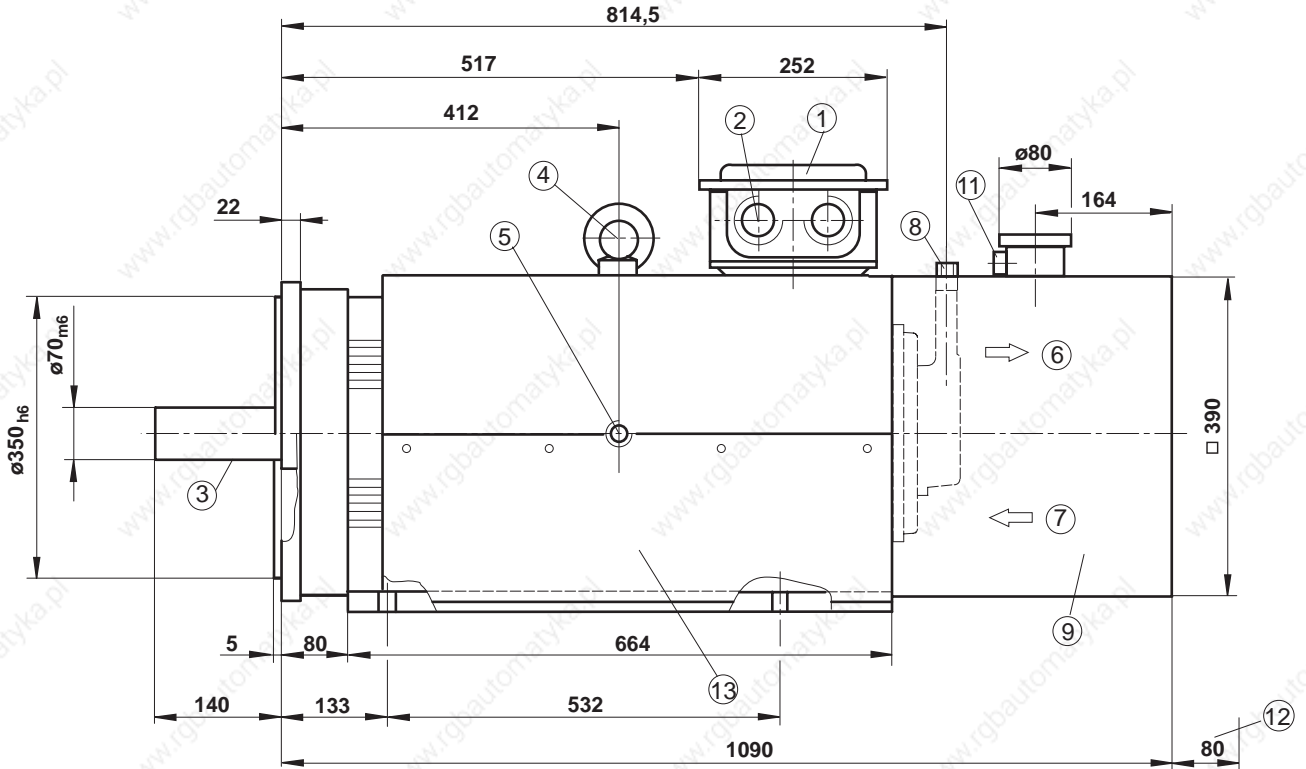

Motor with radial blower and feedback type 3, B35

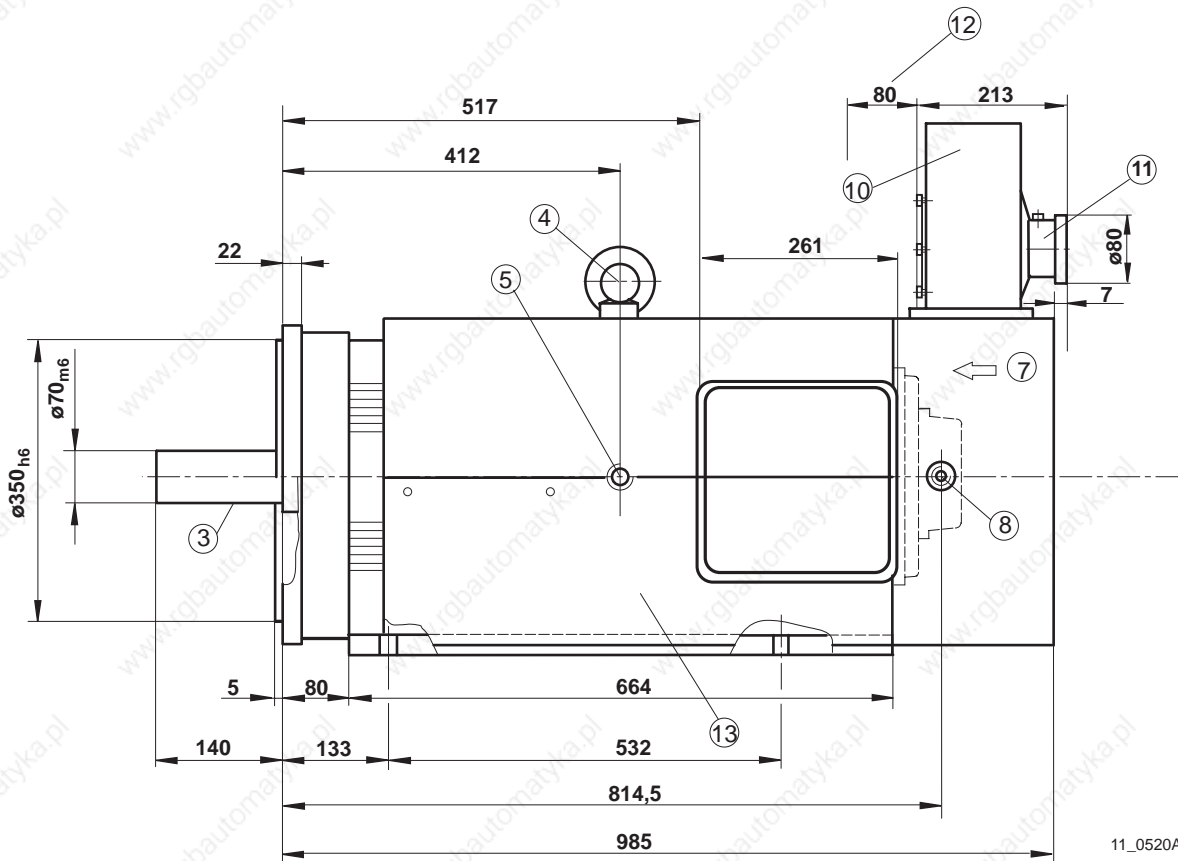

11_0520A

11. Technical data 2AD200

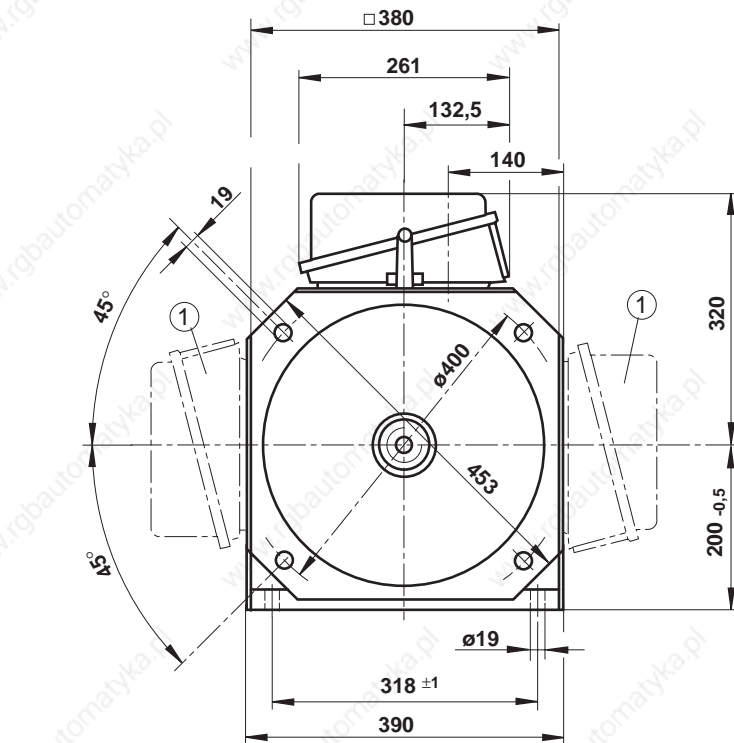

- ① power connection; arrangement selectable, can be turned by 90°, in terms of output direction of power connection
- ② cable output: PG 48
- ③ plain shaft end concentricity tolerance DIN 42955 - R; center drill hole on front DIN 332 DS M20x42
- ④ ring screws M20 - DIN 580
- ⑤ add. threads M20 for ring screws; second thread opposite
- ⑥ air flow A → B
- ⑦ air flow B → A
- ⑧ Motor feedback conn. type 3 (flanged socket), allocation per position of power connection
- ⑨ Axial blower
- ⑩ Radial blower
- ⑪ Motor blower connection terminal box with cable threaded joint
- ⑫ Mounting distance (min. clearance for taking in air for cooling).
- ⑬ Air baffle
- ⑭ output shaft with key; concen. tolerance: DIN 42955 - R; key: DIN 6885 - A 20 x 12 x 110 (part of delivery)

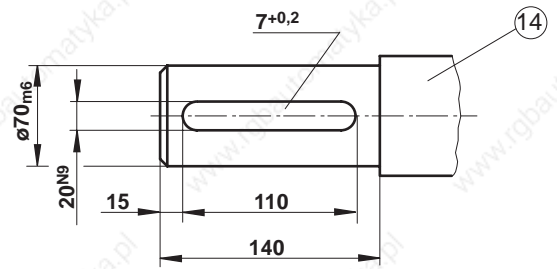
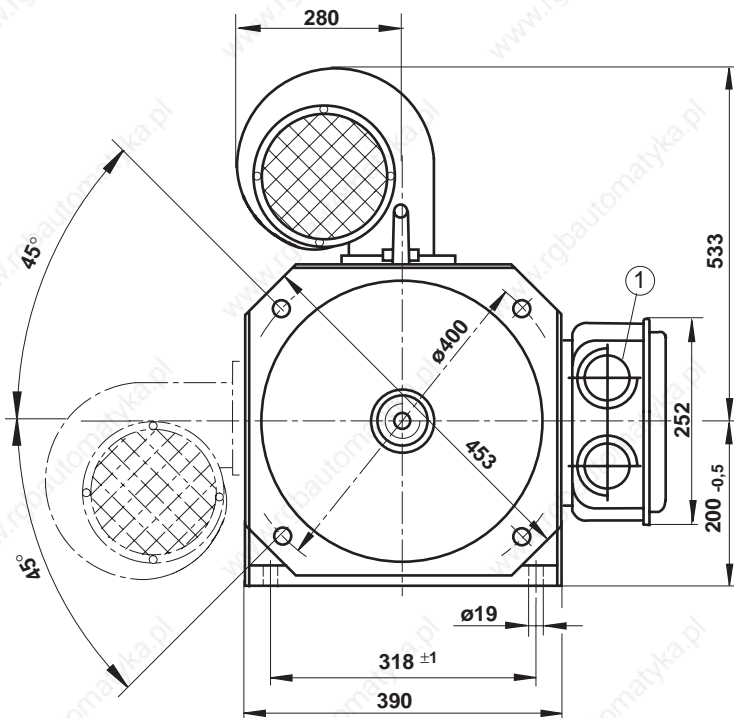

Tolerances:

Dim. to	6	30	120	400	1000	2000
Tolerance	±0,1	±0,2	±0,3	±0,5	±0,8	±1,2

For available designs see Fig.11.8 - type codes

11_0520B

11. Technical data 2AD200

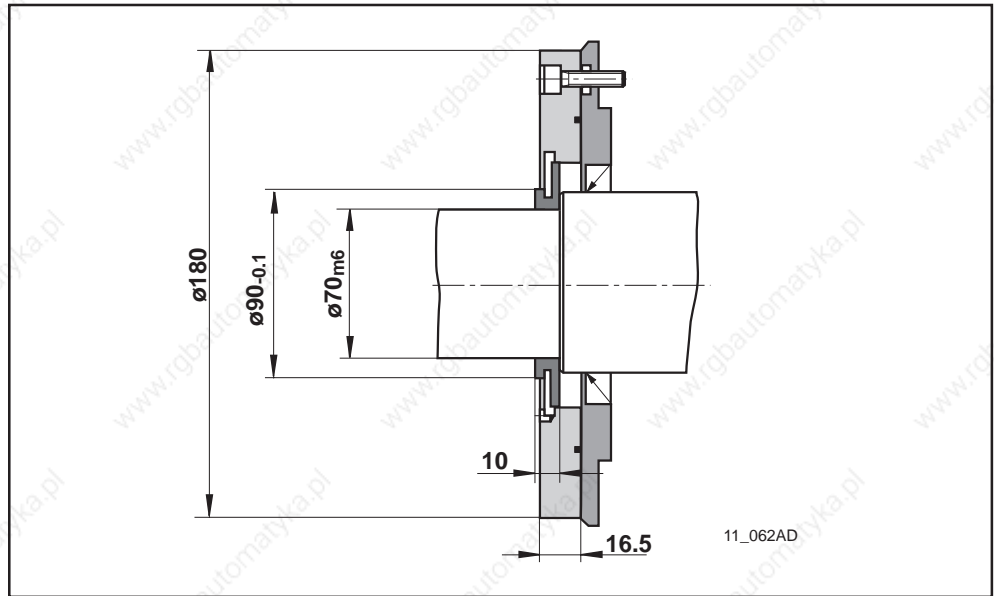

Fig. 11.6: 2AD200 with mounted accessories - M02 2AD200 (labyrinth seal)

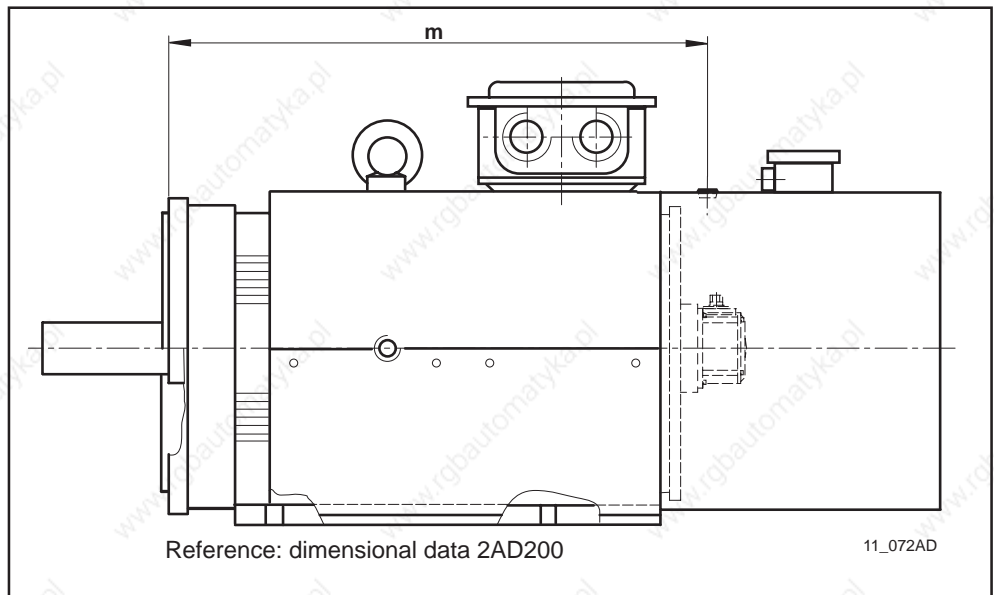

Fig. 11.7: 2AD200 with feedback types 6, 7

11.4 Type codes

Type codes:	Example:	2AD200C-B35OB1-AS03-A2N1																
1. Name:	2AD																	
2. Motor size:	200																	
3. Motor length:	C																	
4. Construction: Flange and foot mounting	B35																	
5. Position of power connection: top left right	O L R																	
6. Output direction of power connection: to side A, terminal box to side B, terminal box to the right, terminal box to the left, terminal box	A B R L																	
7. Cooling mode: Axial blower (Air current B --> A) Axial blower (Air current A --> B) radial blower (Air current B --> A), Blower top **) radial blower (Air current B --> A), Blower right **) radial blower (Air current B --> A), Blower bottom **) radial blower (Air current B --> A), Blower left **)	1 2 3 6 7 8																	
8. Windings ID letters: 2AD200C	AS																	
9. Holding brake: without	0																	
10. Motor feedback: high-resolution motor feedback digital servo feedback digital servo feedback with integral multiturn absolute encoder	3 6 7																	
11. Output shaft:																		
	<table border="1"> <thead> <tr> <th></th> <th>plain shaft</th> <th colspan="2">with key</th> </tr> <tr> <th></th> <th></th> <th>with whole key balanced</th> <th>with half key balanced</th> </tr> </thead> <tbody> <tr> <td>without shaft sealing ring</td> <td>A</td> <td>B</td> <td>E</td> </tr> <tr> <td>with shaft sealing ring</td> <td>C</td> <td>D</td> <td>H</td> </tr> </tbody> </table>			plain shaft	with key				with whole key balanced	with half key balanced	without shaft sealing ring	A	B	E	with shaft sealing ring	C	D	H
	plain shaft		with key															
			with whole key balanced	with half key balanced														
without shaft sealing ring	A	B	E															
with shaft sealing ring	C	D	H															
12. B-side shaft end: without	2																	
13. bearings: Standard heavy-duty	N V																	
14. vibration severity level: R S S1 ****)	1 2 3																	

*) looking towards motor shaft, direction per power connection
 **) blower position may not be the same as that of the power connection
 ****) not available with heavy-duty bearings

Quellverweis: INN 41.01 section 20-0, Ausg. 1

Fig. 11.8: Type codes 2AD200

Notes

12. Technical data 2AD225

12.1 Nominal data

Name	Symbol	Unit	2AD225
Motor size			C
Windings ID letters			AS
Nominal power ¹⁾	P_n	kW	93
Nominal torque ¹⁾	M_n	Nm	592
Motor nominal speed	n	min ⁻¹	1500
Maximum speed	n_{max}	min ⁻¹	5000 standard bearings
			4500 heavy-duty bearings
Nominal current	I_n	A _{eff}	210
Nominal voltage	U_n	V _{eff}	330
Rotor moment of inertia ²⁾	J_M	kgm ²	1,05
Thermal time constant	t_{th}	min	130
Minimum conn. cross section EN 60204 section 1/02.86	A	mm ²	2 x 35
Average noise level at 1m (PWM=4kHz)	L_p	dB(A)	78±3
Mass ³⁾	m	kg	705
Ambient temperature		°C	0 ... 45
Insulation classification DIN VDE 0530 section 1			F
Vibration severity level ⁴⁾ DIN ISO 2373			R, S, S1
<p>¹⁾ Values determined per DIN VDE 0530 section 1 For the selection of an AC main spindle motor, curves are available for the specified nominal powers which take operating modes S1, S2 and S6 into consideration.</p> <p>²⁾ Values without holding brakes</p> <p>³⁾ Values without holding brakes, with blower</p> <p>⁴⁾ For values see Fig. 2.7 "RMS vibration speed".</p>			

Fig. 12.1: Nominal data 2AD225

Permissible shaft load

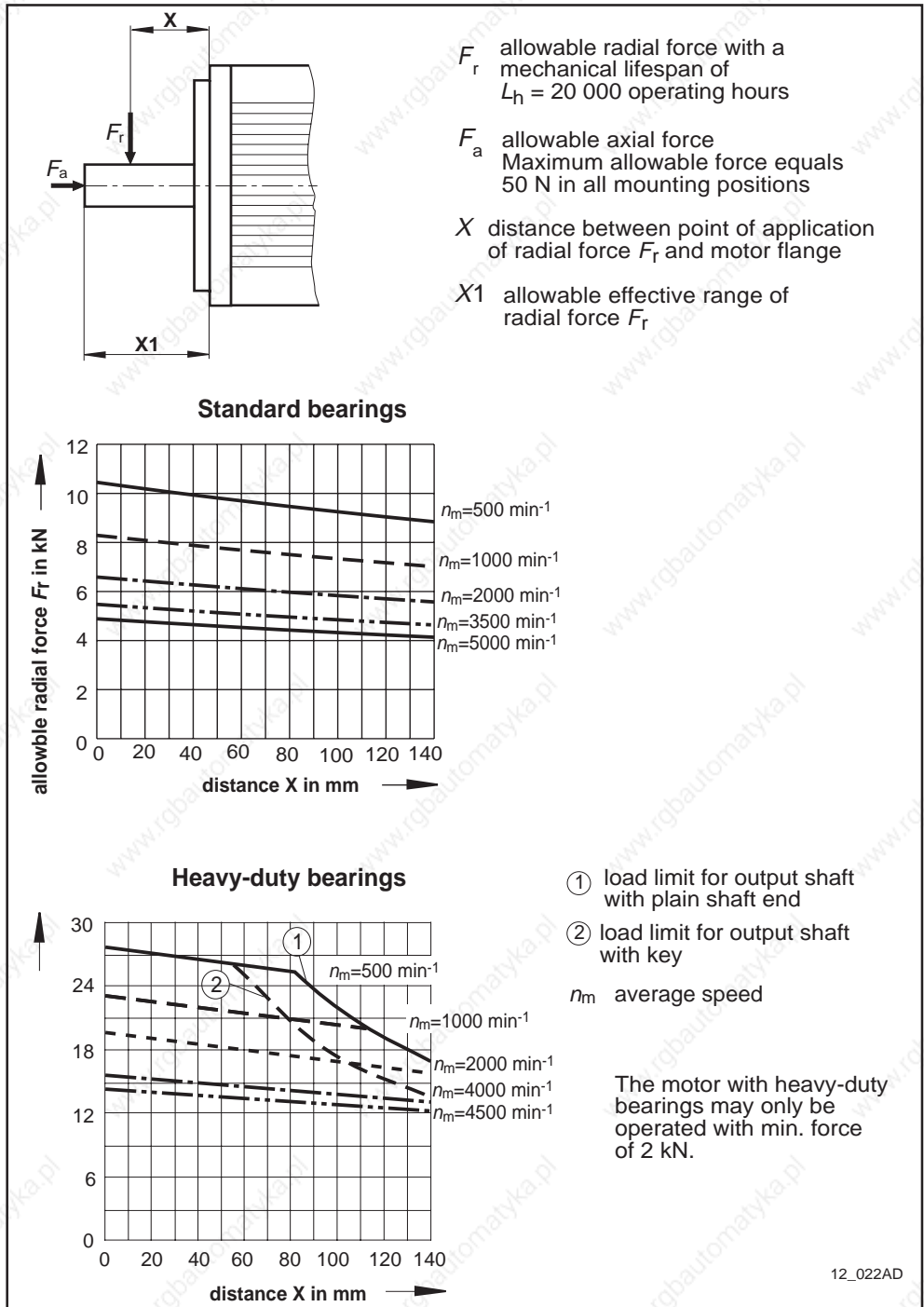

Fig. 12.2: Permissible shaft load 2AD225

Lubricant consumption

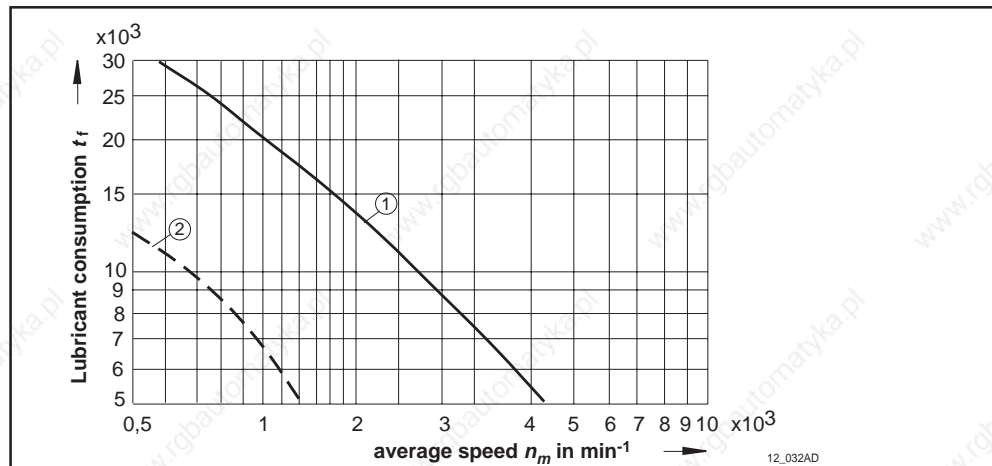

Fig. 12.3: Lubricant consumption 2AD225

12.2 Motor blower

Designation	Symbol	Unit	Design		
			axial blower		radial blower
Air current			B → A blowing (recommended)	A → B suction	A → B blowing
Power consumption	S_N	VA	460		500
Nominal voltage	U_N	V	3 x AC, 400V, 50/60Hz 3 x AC, 460V, 60Hz		
Average air volume	V	m ³ /h	3500		

Fig. 12.4: Technical data of motor blower on 2AD225

12. Technical data 2AD225

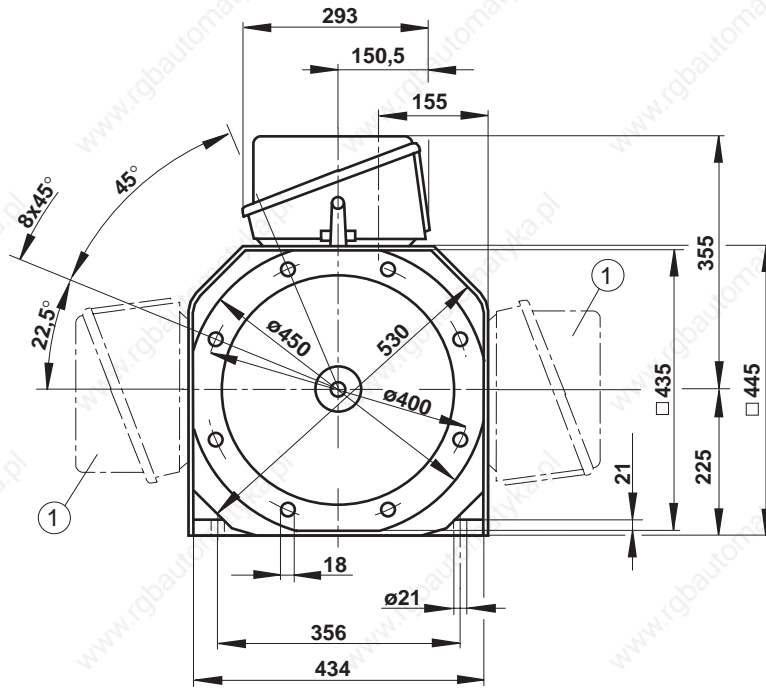

- ① Power connection
- ② cable output: PG 48
- ③ plain shaft end concentricity tolerance DIN 42955 -R; center drill hole on front DIN 332 DS M20x42
- ④ ring screws M20 - DIN 580
- ⑤ add. threads M10 for ring screws; second thread opposite
- ⑥ air flow A → B
- ⑦ air flow B → A
- ⑧ Motor feedback conn. type 3 (flanged socket), allocation per position of power connection
- ⑨ Axial blower
- ⑩ Motor blower connection terminal box with cable threaded joint
- ⑪ Mounting distance (min. clearance for taking in air for cooling).
- ⑫ output shaft with key; concen. tolerance: DIN 42955 - R; key: DIN 6885 - A 20 x 12 x 110 (part of delivery)
- ⑬ Air baffle
- ⑭ Motor feedback conn. types 6, 7 (flange socket), arranged in terms of the position of the power connection

Tolerances:

Dim.	6	30	120	400	1000	2000
Tolerance	±0,1	±0,2	±0,3	±0,5	±0,8	±1,2

For available designs see Fig.11.8 - type codes

12_05225B

Fig. 12.5: Dimensions for 2AD225

12.4 Type codes

Type codes:	Example:	2AD225C-B35OB1-AS03-A2N1
1. Name:	2AD	
2. Motor size:	225	
3. Motor length:	C	
4. Construction: Flange and foot mounting	B35	
5. Position of power connection: top left right	O L R	
6. Output direction of power connection: to side A, terminal box to side B, terminal box to the right, terminal box to the left, terminal box	A B R L	
7. Cooling mode: Axial blower (Air current B --> A) Axial blower (Air current A --> B)	1 2	
8. Windings ID letters: 2AD225C	AS	
9. Holding brake: without	0	
10. Motor feedback: high-resolution motor feedback digital servo feedback digital servo feedback with integral multiturn absolute encoder	3 6 7	
11. Output shaft:		
	plain shaft	with key with whole key balanced
without shaft sealing ring	A	B
with shaft sealing ring	C	D
		with half key balanced
		E
		H
12. B-side shaft end: without	2	
13. bearings: Standard heavy-duty	N V	
14. vibration severity level: R S S1 ****)	1 2 3	

*) looking towards motor shaft, direction per power connection
 **) blower position may not be the same as that of the power connection
 ****) not available with heavy-duty bearings

Quellverweis: INN 41.01 section 22-5, Ausg.1

Fig. 12.6: Type codes 2AD225

13. Mechanical Accessories

13.1 Blower base

Blower base
M01 2AD132/134

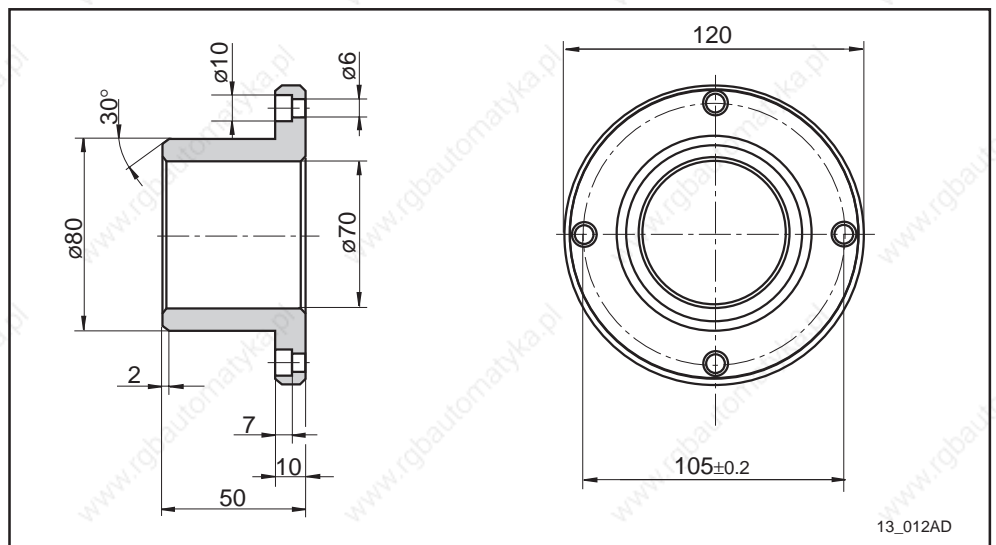

Fig. 13.1: Dimensions of blower base for 2AD132/134

Blower base
M01 2AD160/164

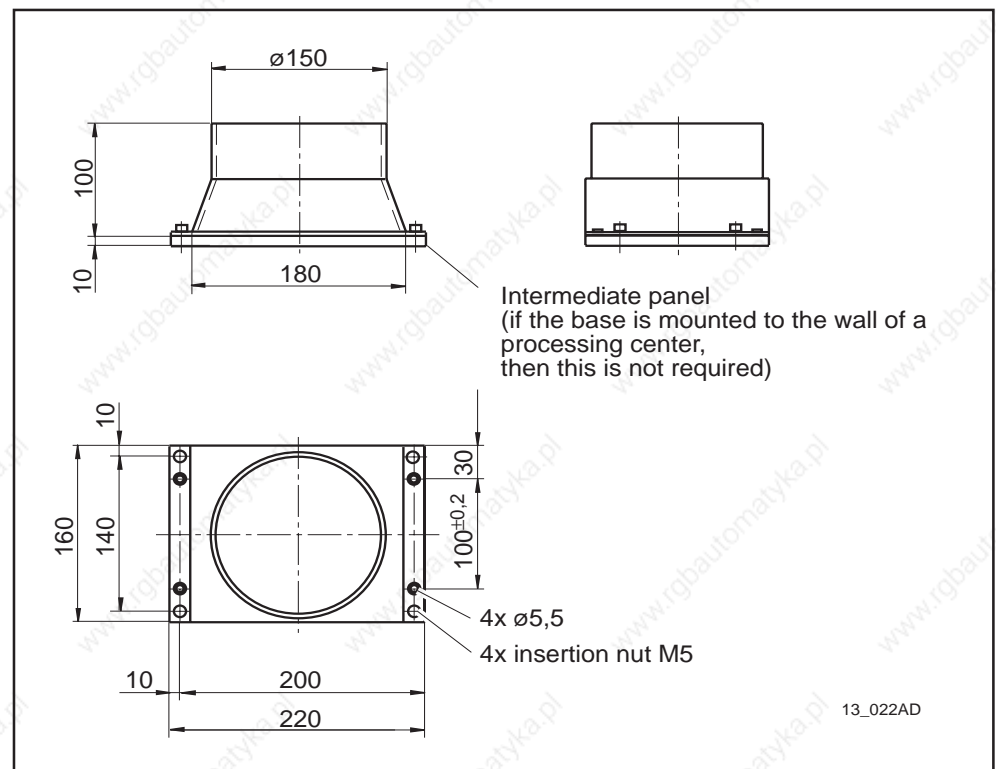

Fig. 13.2: Dimensions of blower base for 2AD160/164

13. Mechanical Accessories

Blower base
M01 2AD180

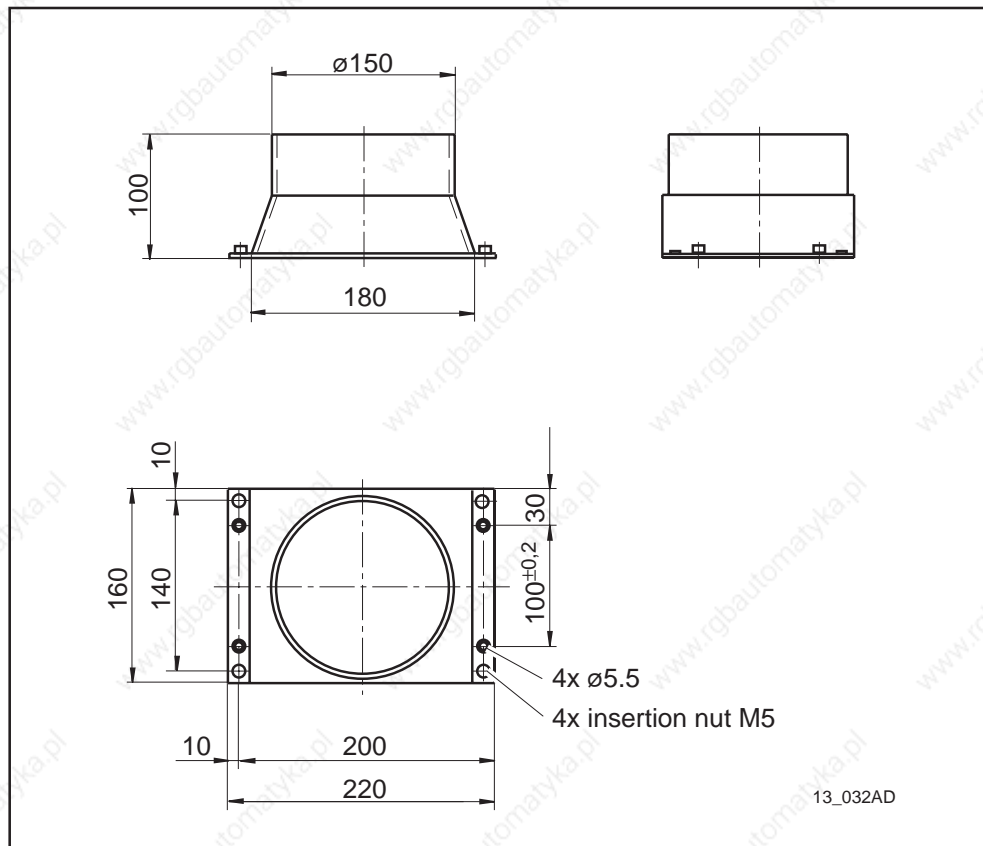

Fig. 13.3: Dimensions of blower base for 2AD180

13.2 Labyrinth seal

Labyrinth seal
M02 2AD...

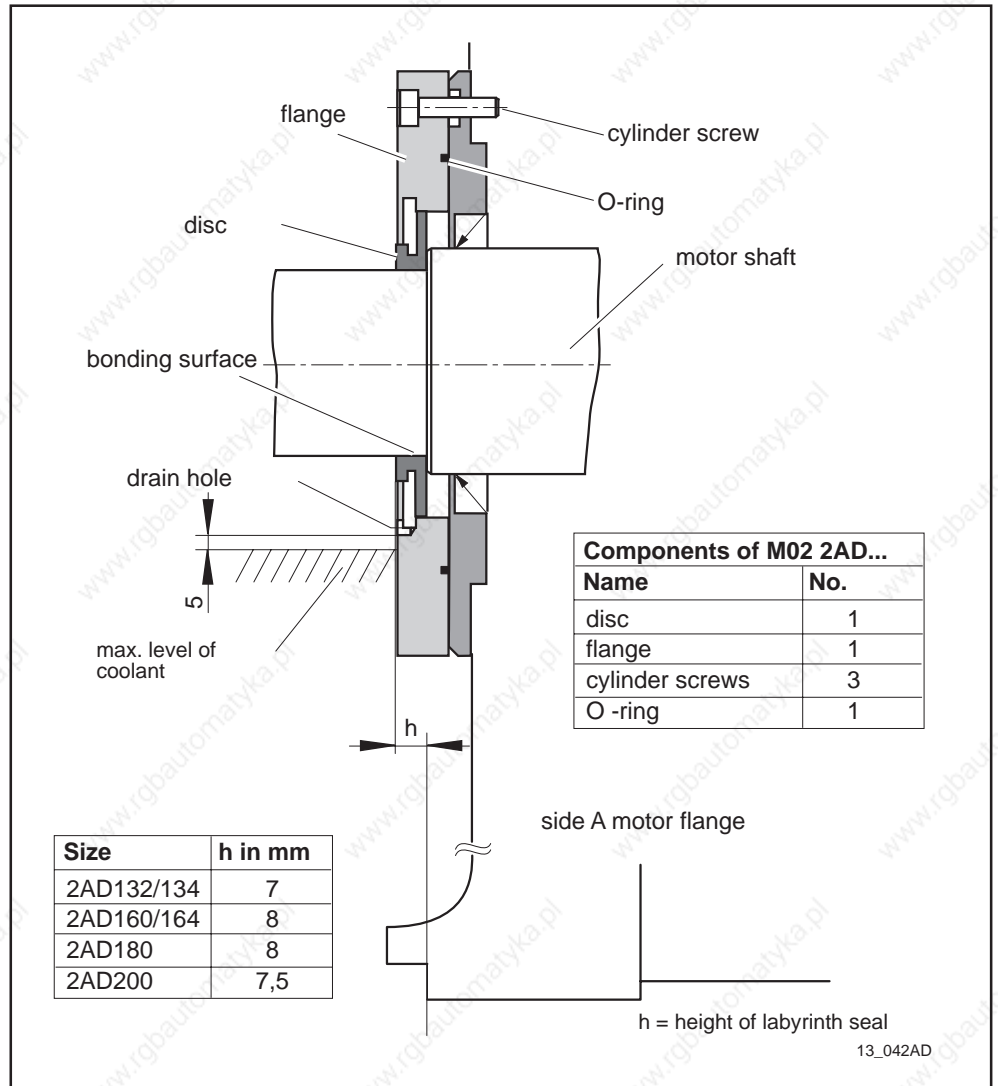

Fig. 13.4: Construction principle of the labyrinth seal

13. Mechanical Accessories

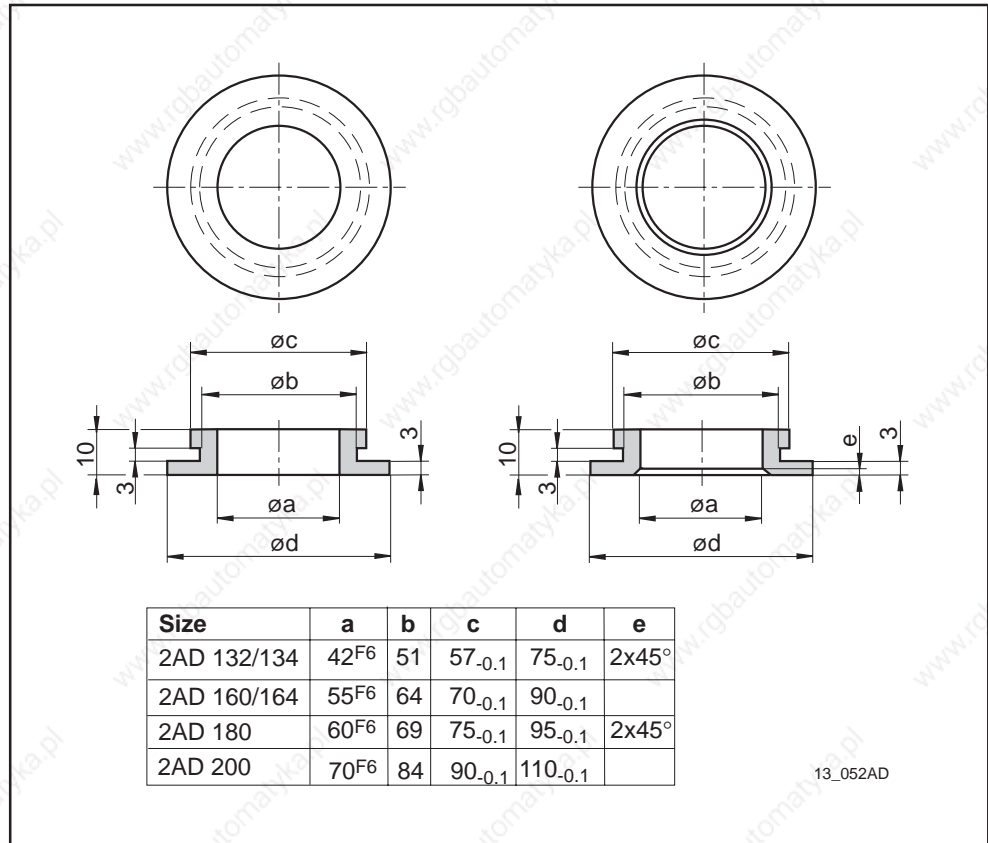

Fig. 13.5: Disc of mechanical accessories M02 2AD...

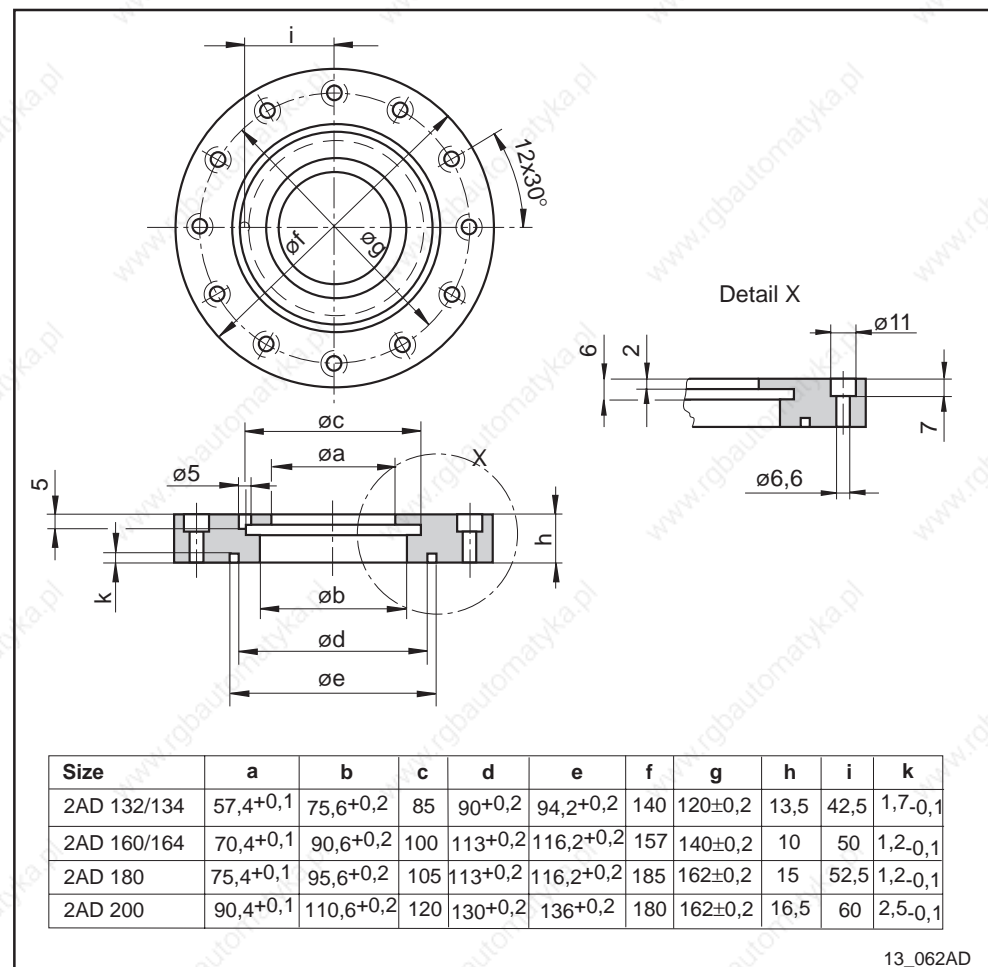

Fig. 13.6: Flange of the mechanical accessories M02 2AD...

14. Electrical connections

14.1 Motor power connections

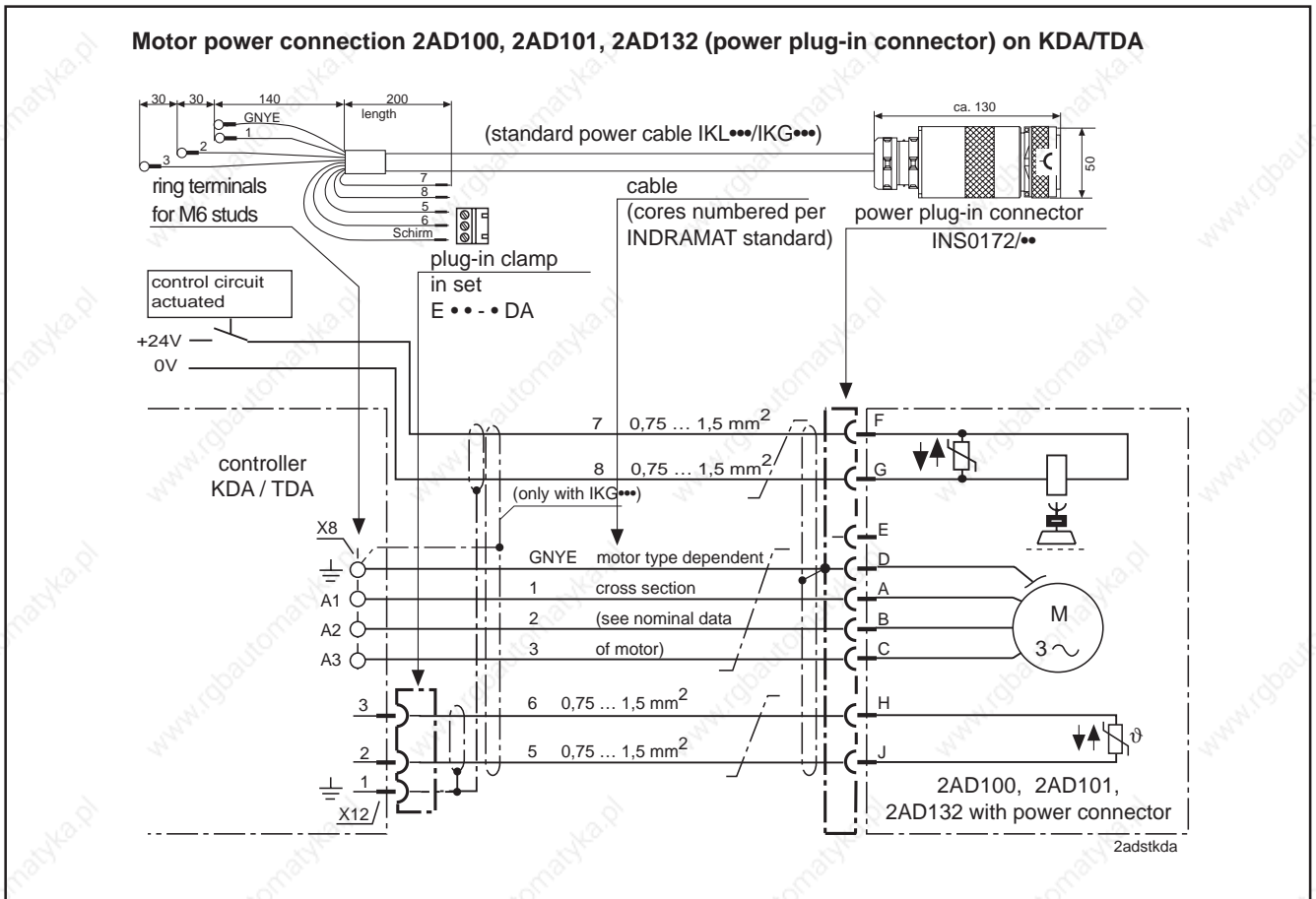

Fig. 14.1: Terminal diagram for motors with power connector on KDA/TDA

14. Electrical connections

Motor power connection 2AD100, 2AD101, 2AD132 (power plug-in connector) on DDS02.2

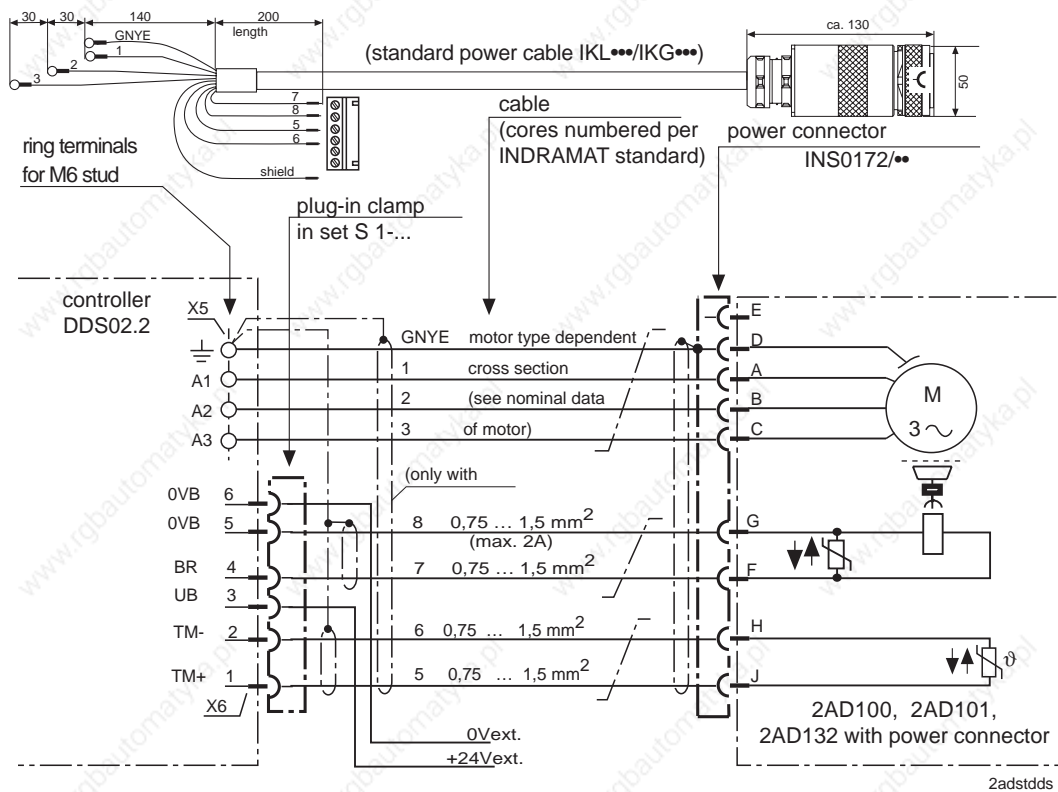

Fig. 14.2: Terminal diagram for motors with power plug-in connector on DDS02.2

Motor power connection 2AD104 (power plug-in connector) on HDS02

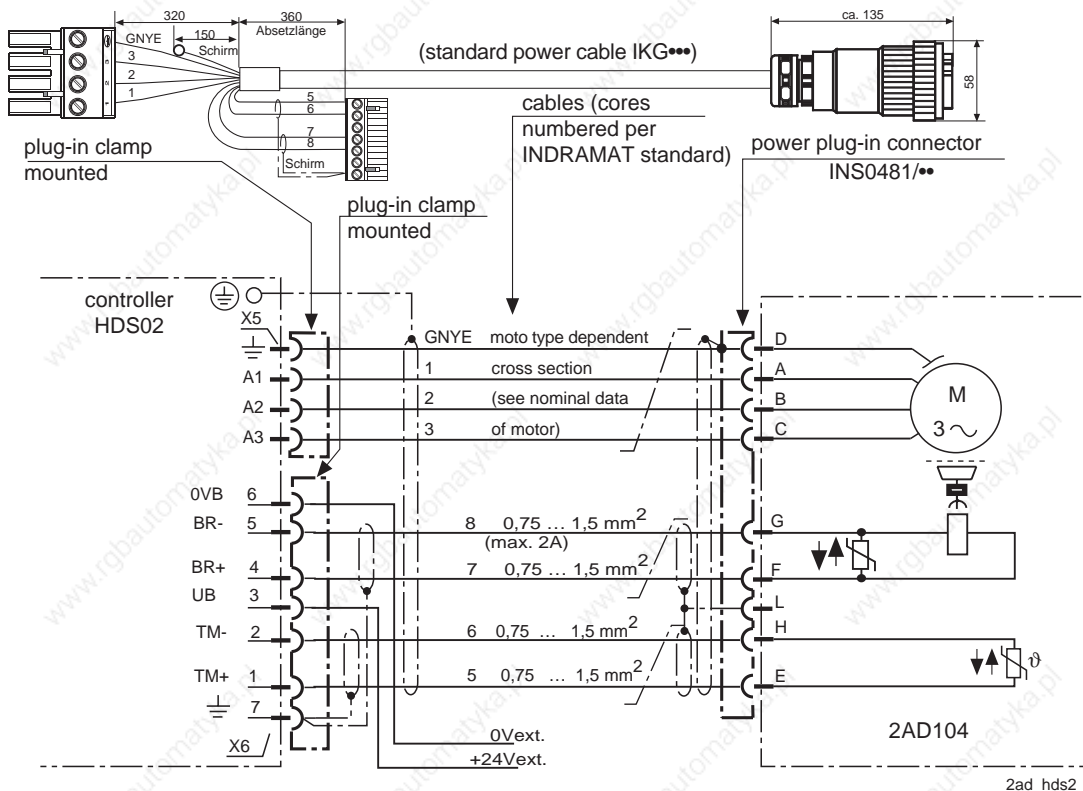

Fig. 14.3: Terminal diagram for motors with power plug-in connector on HDS02

14. Electrical connections

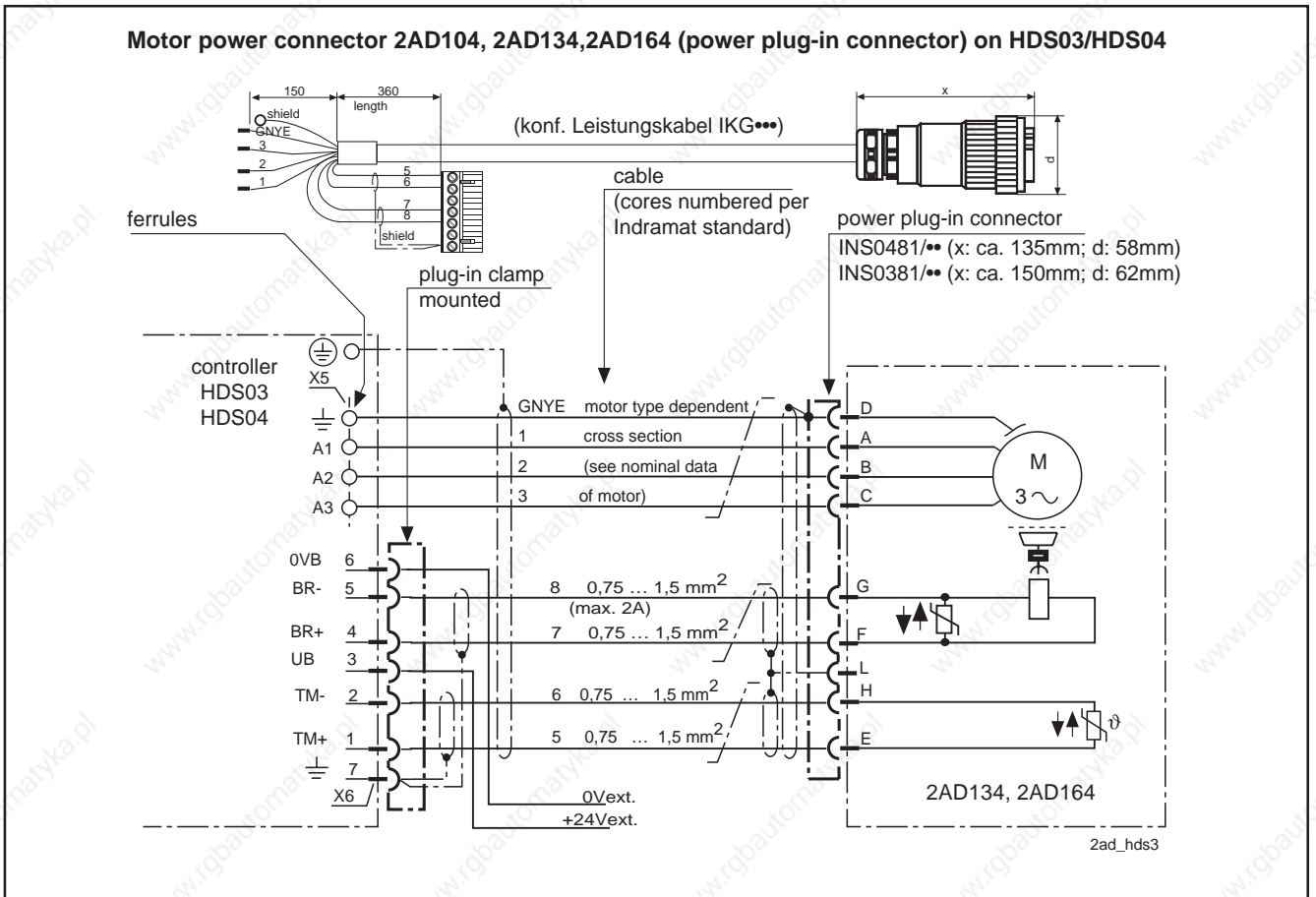

Fig. 14.4: Terminal diagram for motors with power plug-in connector on HDS03/HDS04

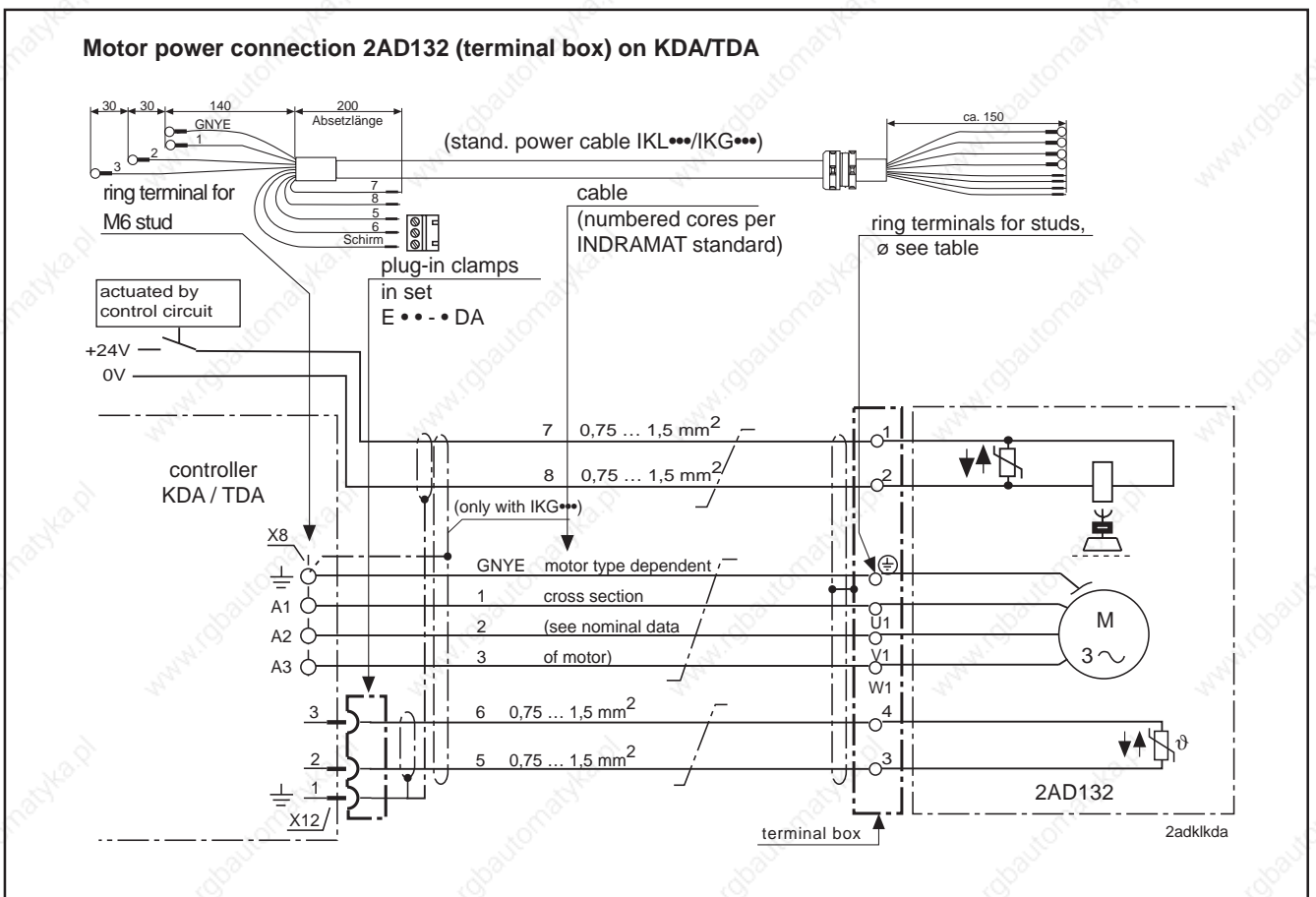

Fig. 14.5: Terminal diagram for motors with terminal box on KDA/TDA

14. Electrical connections

Motor power connection 2AD132 (terminal box) on DDS02.2

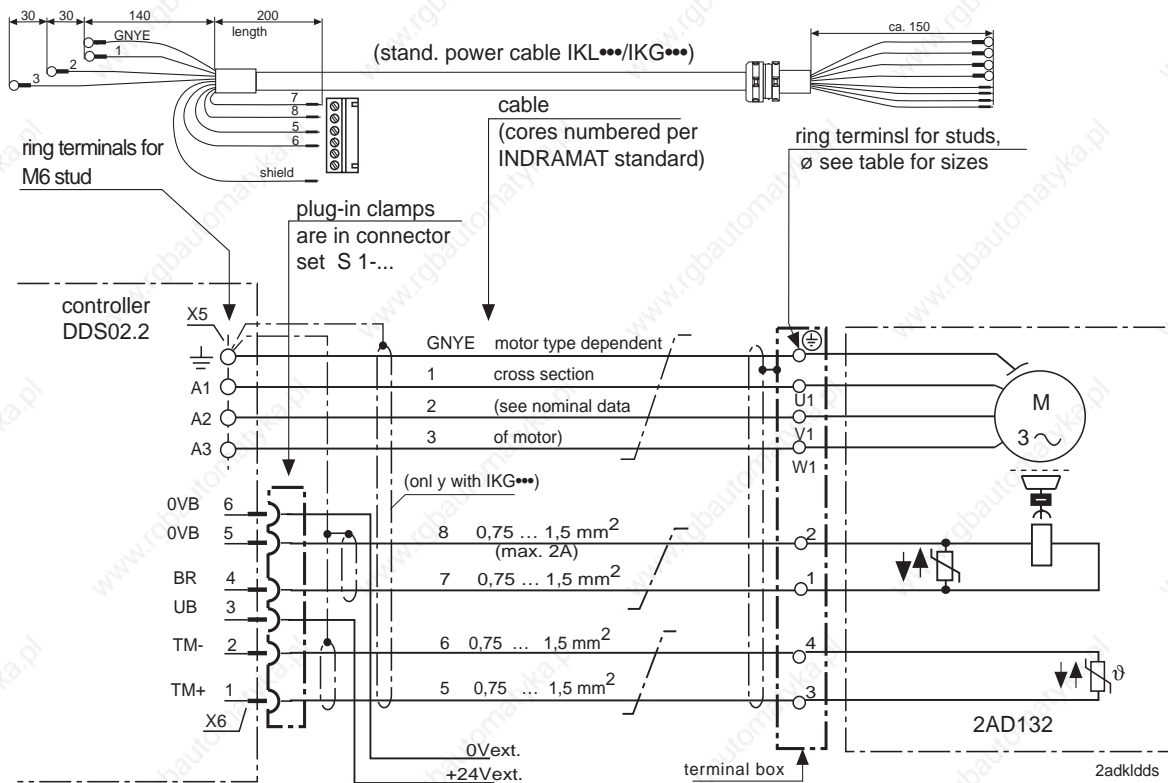

Fig. 14.6: Terminal diagram for motors with terminal box on DDS02.2

Motor power connection 2AD132 (power plug-in connector) on RAC

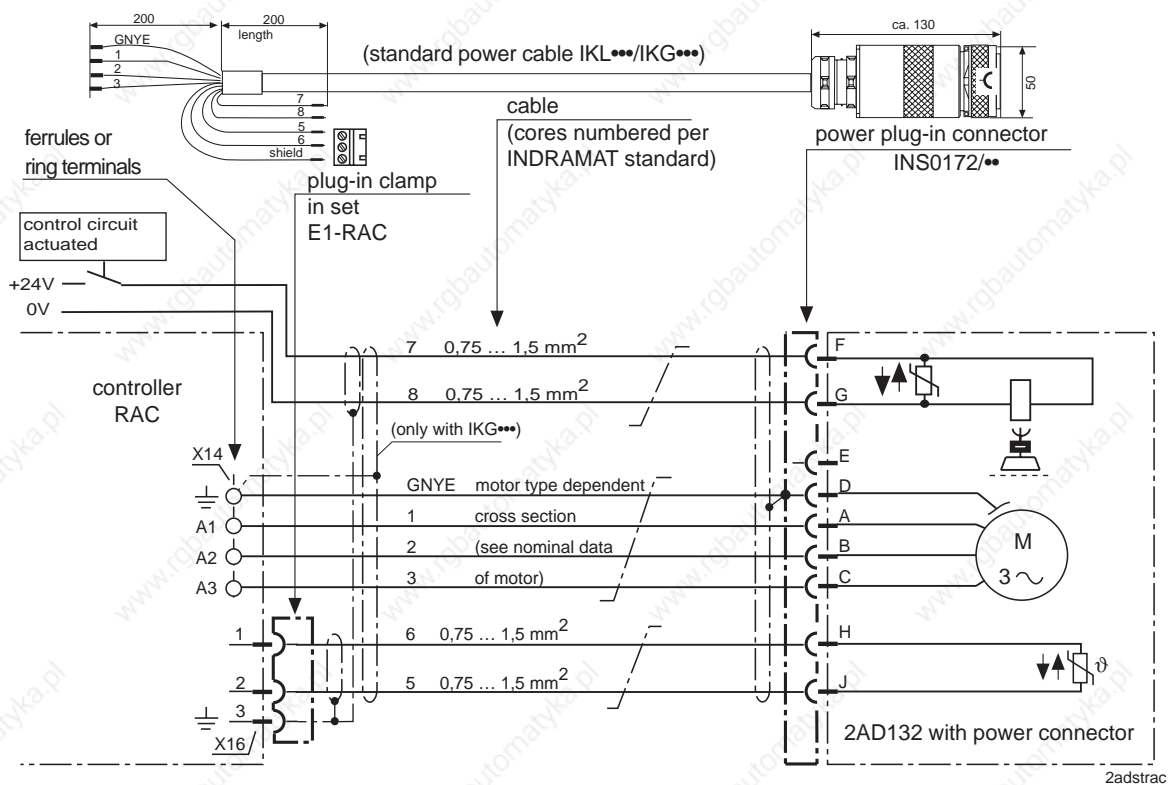

Fig. 14.7: Terminal diagram for motors w/ power plug-in connector at RAC

14. Electrical connections

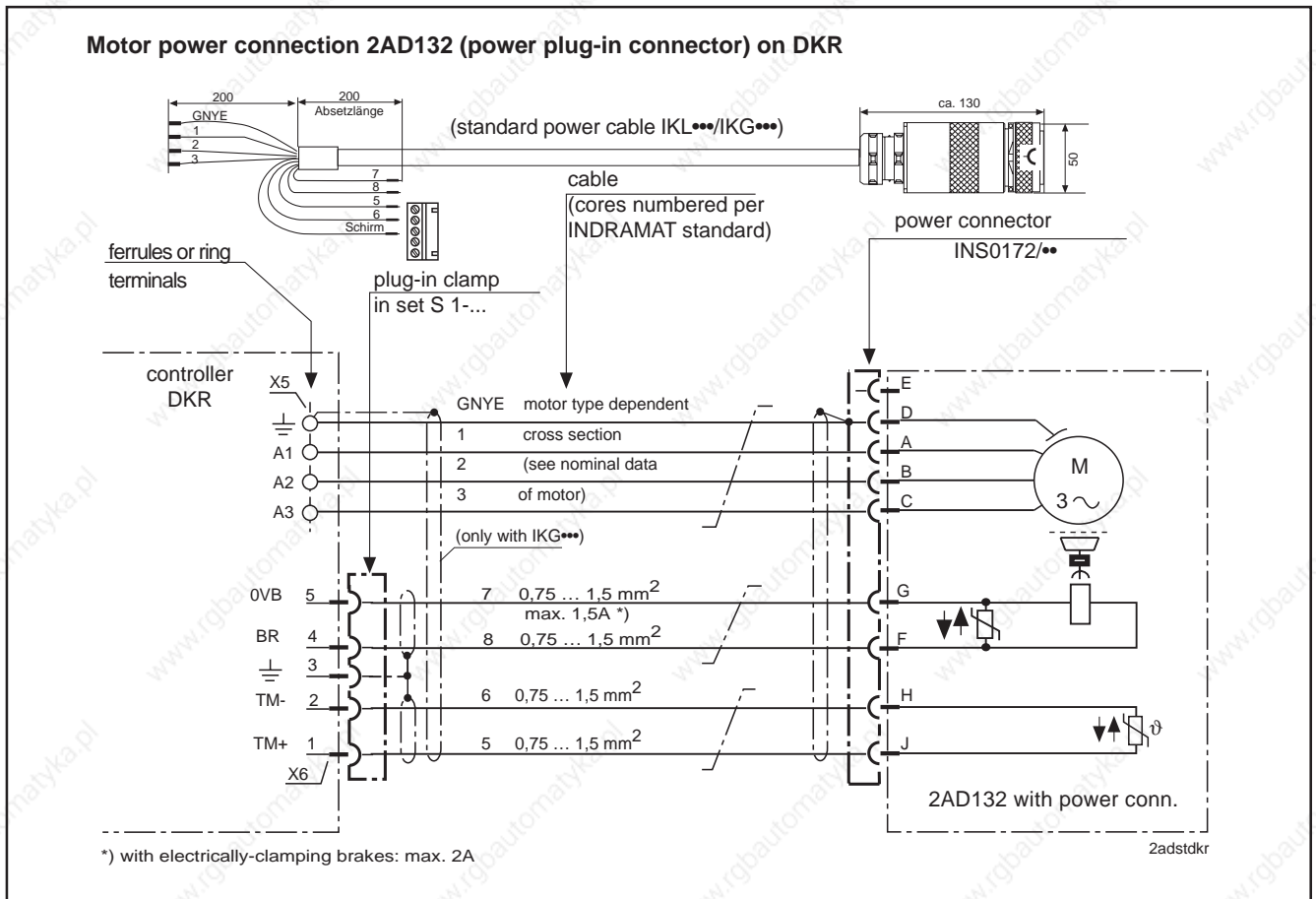

Fig. 14.8: Terminal diagram for motors with power plug-in connector on DKR

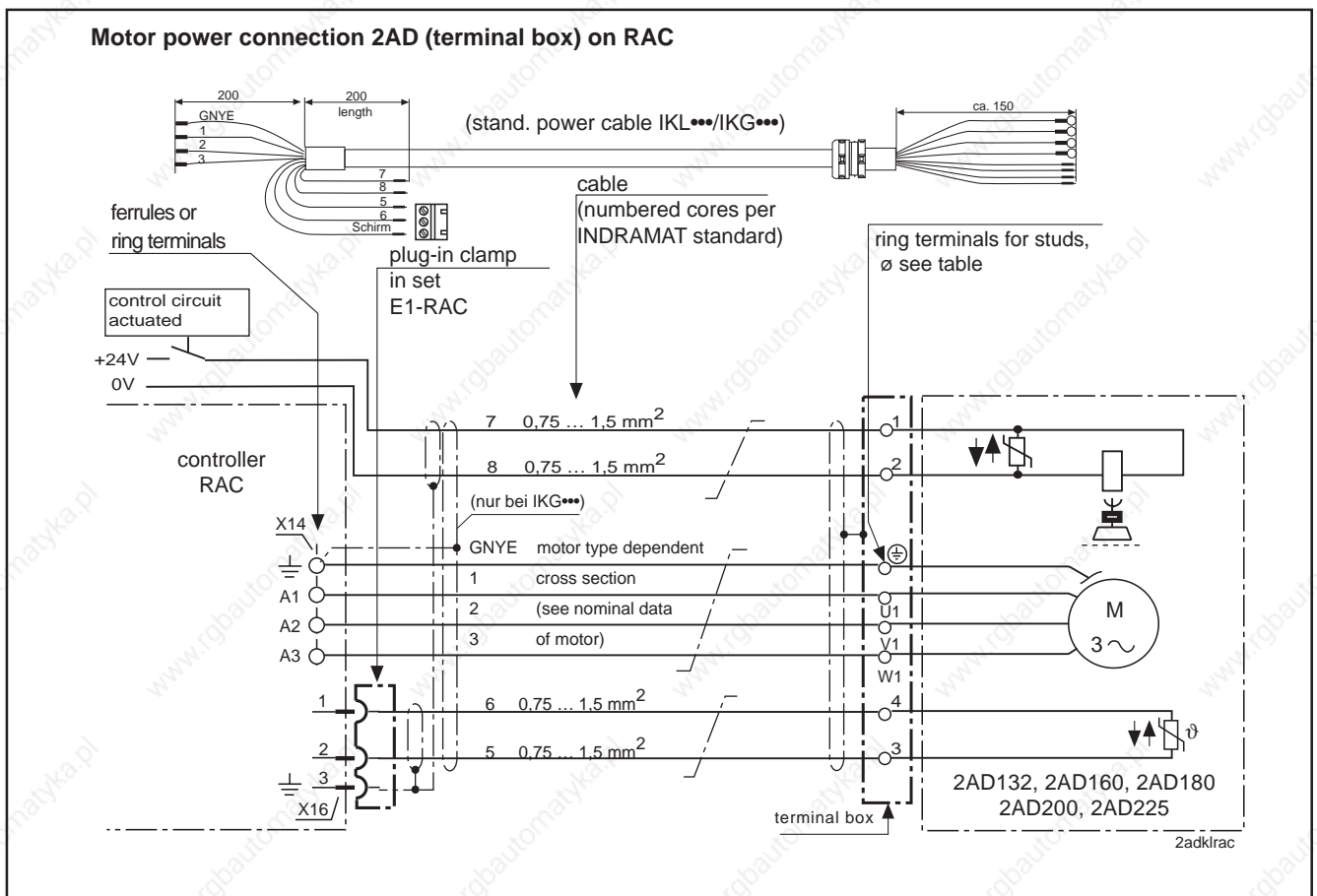

Fig. 14.9: Terminal diagram for motors with terminal box on RAC

14. Electrical connections

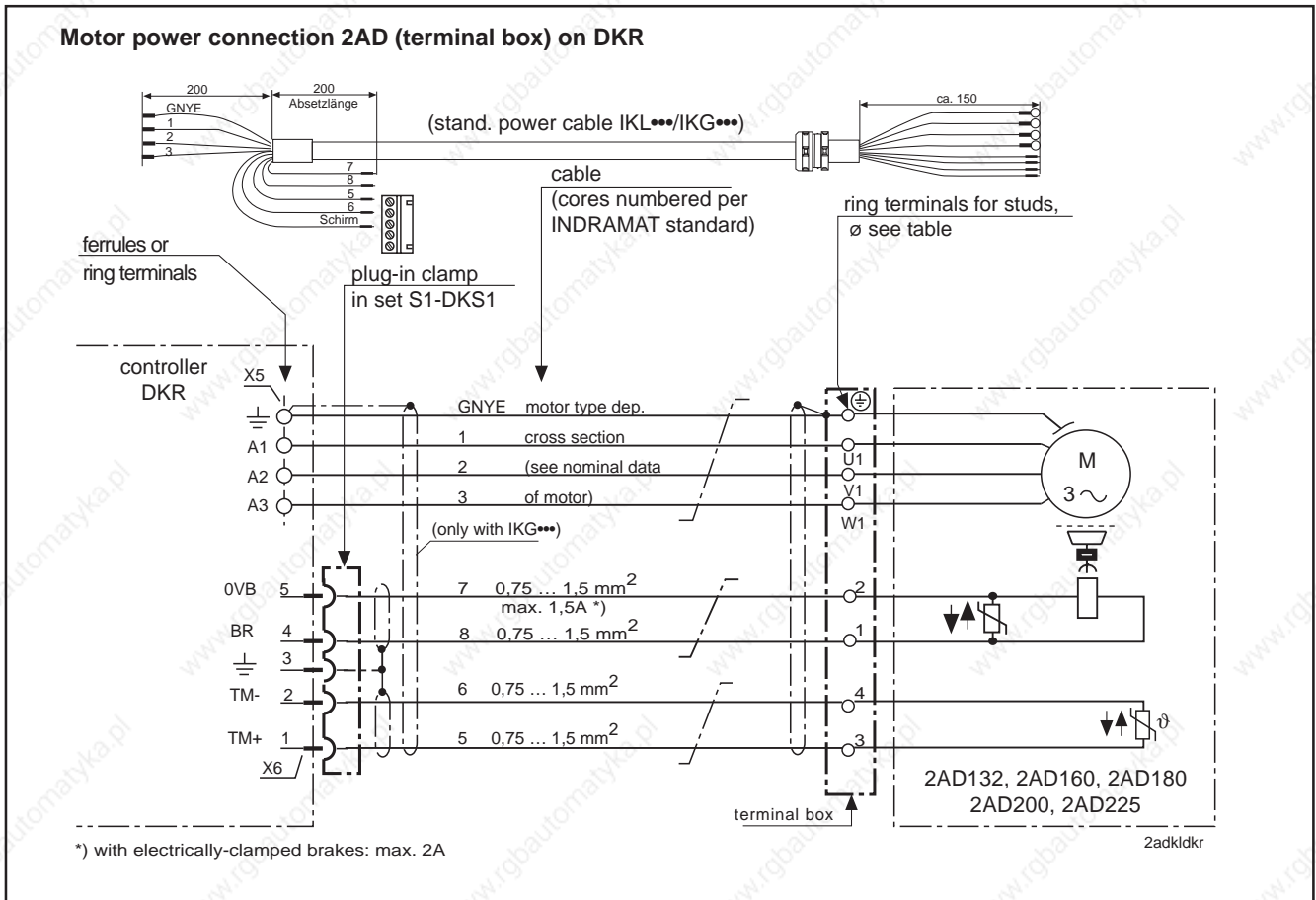
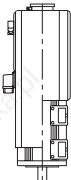









Fig. 14.10: Terminal diagram for motors with terminal box on DKR

14.2 Motor Power Cables

The required cable cross sections depend on the motor type. They are listed in the relevant Technical Data documentation.

Motor type	Conn. to drive	Cable cross section of INK... A [mm ²]	Ready-made cables for direct connection		Components for standard cables for direct connection			Standard cables for intermediate clamping to terminal strip				
			flex./flex., shielded	on the motor	on the motor	flex./flex., shielded	on controller	on the motor	on the controller			
	KDA TDA DDS	4		INS0172/10	INK0203/INK0603	For...			not available			
			IKL0071/IKG0071	INS0172/10	INK0203/INK0603	...Studs M6 (KDA/TDA/DDS)	IKL0134/IKG0134	not available				
			IKL0159/IKG0159	INS0172/16	INK0204/INK0604	...Studs M6 (KDA/TDA/DDS)	IKL0150/IKG0150	not available				
			IKL0130/IKG0130	INS0172/10	INK0205/INK0605	...Studs M6 (KDA/TDA/DDS)	IKL0134/IKG0134	not available				
			IKL0159/IKG0159	INS0172/16	INK0206/INK0606	...Studs M6 (KDA/TDA/DDS)	IKL0150/IKG0150	not available				
			IKL0170/IKG0170	INS0172/25	INK0207/INK0607	...Studs M6 (KDA/TDA/DDS)	IKL0179/IKG0179	not available				
			RAC2 RAC3 DKR2 DKR3		10		INS0172/10	INK0205/INK0605	For...			not available
						IKL0134/IKG0134	INS0172/10	INK0205/INK0605	...terminal block (RAC2/3, DKR2/3)	s. vorne	not available	
						IKL0150/IKG0150	INS0172/16	INK0206/INK0606	...terminal block (RAC2/3, DKR2/3)	s. vorne	not available	
						IKL0150/IKG0150	INS0172/16	INK0206/INK0606	...terminal block (RAC2/3, DKR2/3)	s. vorne	not available	

2ADKAB01

Symbols:



















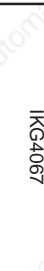



-  power plug-in connector
-  conduit thread
-  ring terminals
-  ferrules
-  ring terminals

Fig. 14.11: Standard motor power cables for motors with power connector, section I

14. Electrical connections

The required cable cross sections depend on the motor type. They are outlined in the relevant Technical Data.

Motor type	Contr. conn.	INK... cross section A [mm ²]	Standard cable for direction conn. flex./flex., shielded	Standard cable components for direct connection motor cable flex./flex., shielded	controller For...	Standard cable for intermediate clamping to terminal block motor flex./flex., shielded	controller flex./flex., shielded
ZAD104B--CS	HDS02	1,5	 IKG4055	 INS0481/CO2	...plug-in clamps	 IKG4053	not available
ZAD104C--CS	HDS02	2,5	 IKG4067	 INS0481/CO3	...terminal block/ plug-in clamps	 IKG4063	not available
ZAD104D--FS ZAD104D--ES	HDS03/ HDS04	4	 IKG4087	 INS0481/CO4	...terminal block/ plug-in clamps	 IKG4083	not available
ZAD134B--ES	HDS03/ HDS04	6	 IKG4107	 INS0481/CO4	...terminal block/ plug-in clamps	 IKG4103	not available
ZAD134B--FS ZAD134C--DS ZAD134D--CS	HDS03/ HDS04	10	 IKG4167	 INS0381/C10	...terminal block/ plug-in clamps	 IKG4163	not available
ZAD164B--DS	HDS03/ HDS04	16	 IKG4186	 INS0381/C16	...terminal block/ plug-in clamps	 IKG4183	not available











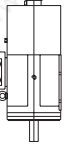



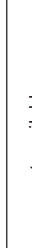

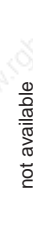



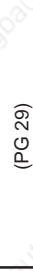

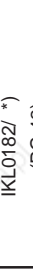
ZADKAB03

Fig. 14.12: Standard motor power cables for motors with power connector, section II

14. Electrical connections

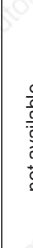
The required cable cross sections depend on the motor type. They are listed in the relevant Technical Data documentation.

Motor type 	Conn. to drive	Cable cross section of INK... A [mm ²]	Ready-made cables for direct connection flex./flex., shielded	Components for standard cables for direct connection		Standard cables for intermediate clamping to terminal strip	
				on the motor	Leitung flex./flex., shielded	controller	on the motor flex./flex., shielded
2AD132B-.-BS 2AD132C-.-BS 2AD132D-.-BD	KDA TDA DDS	10	 IKL0135/IKG0135 (PG 29)	Für... ..Stehb. M6 ⊕ M8	INK0205/INK0605	For... ..Stud M6 (KDA/TDA/DDS)	 IKL0136/IKG0136 not available
		16	 IKL0157/IKG0157 (PG 29)	..Stehb. M6 ⊕ M8	INK0206/INK0606	..Stud M6 (KDA/TDA/DDS)	 IKL0151/IKG0151 not available
		25	 IKL0174/IKG0174 (PG 29)	..Stehb. M8 ⊕ M8	INK0207/INK0607	..Stud M6 (KDA/TDA/DDS)	 IKL0172/IKG0172 not available
2AD132B-.-DS 2AD132C-.-CS 2AD132D-.-AS 2AD160B-.-BS 2AD160C-.-BS 2AD180C-.-BS	RAC2 RAC3 DKR2 DKR3	6	 IKL0110/IKG0110 (PG 29)	Für... ..Stehb. M6 ⊕ M8	INK0204/INK0604	For... ...terminal block (RAC2/3, DKR2/3)	 see previous column not available
		10	 IKL0136/IKG0136 (PG 29)	..Stehb. M6 ⊕ M8	INK0205/INK0605	...terminal block (RAC2/3, DKR2/3)	 see previous column not available
		16	 IKL0151/IKG0151 (PG 29)	..Stehb. M8 ⊕ M8	INK0206/INK0606	...terminal block (RAC2/3, DKR2/3)	 see previous column not available
		25	 IKL0172/IKG0172 (PG 36)	..Stehb. M8 ⊕ M8	INK0207/INK0607	...terminal block (RAC2/3, DKR2/3)	 see previous column not available
		35	 IKL0182/IKG0182 (PG 42)	..Stehb. M10 ⊕ M10	INK0667	...terminal block (RAC2/3, DKR2/3)	 see previous column not available
2AD180C-.-BS 2AD200C-.-AS 2AD225C-.-AS	RAC4 DKR4	50	 IKL 0191/IKG0191 (PG 42)	Für... ..Stehb. M10 ⊕ M10	INK0268/INK0667 (*)	For... ...screw M12 (RAC4, DKR4)	 see previous column not available
		2x25	 2xIKL0175/2xIKG0175 (PG 48)	..Stehb. M12 ⊕ M12	INK0207/INK0607	...screw M12 (RAC4, DKR4)	 see previous column not available
		2x35	 2xIKL0183/IKG0183 (PG 48)	..Stehb. M12 ⊕ M12	INK0267/INK0667 (*)	...screw M12 (RAC4, DKR4)	 see previous column not available

*) available, request type designations from INDRAMAT, Abt. ENT



2ADKAB02

Fig. 14.13: Standard motor power cables for motors with terminal box

14.3 Motor blower connections

Axial blower conn. in 2AD100 (air flow A=>B)

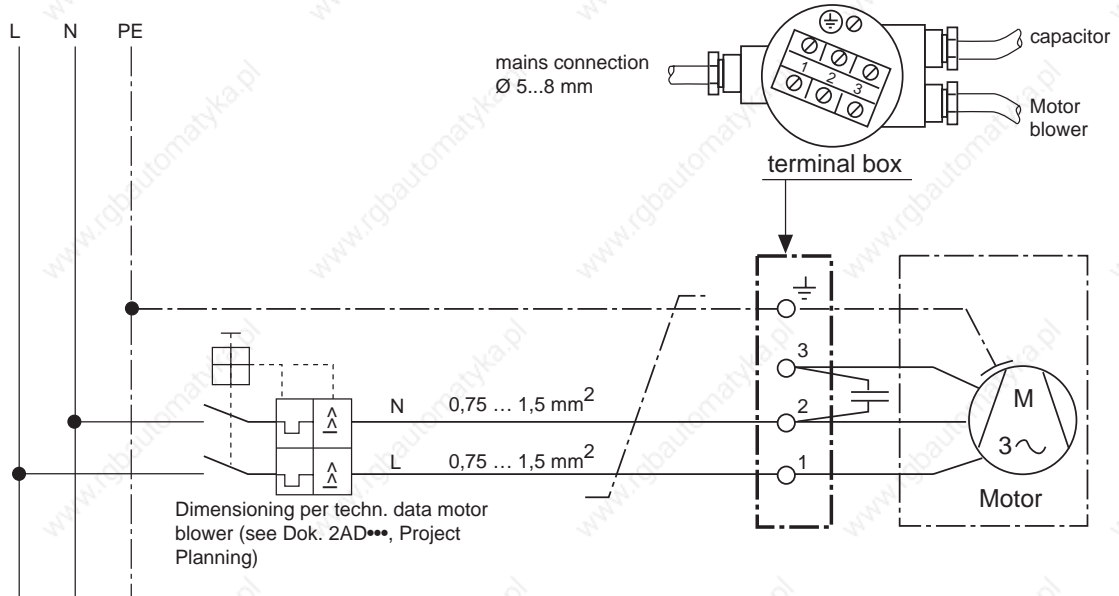

Allowable mains voltage

AC 230 V ±10%, 50...60 Hz :	2AD 100	••••••••••	2	••••••••••	
	2AD 101	••••••••••	* 1	••••••••••	* [{A;B;R;L}
	2AD 101	••••••••••	* 2	••••••••••	* [{A;B;R;L}
AC 115 V ±10%, 50...60 Hz :	2AD 100	••••••••••	5	••••••••••	
	2AD 101	••••••••••	* 5	••••••••••	* [{A;B;R;L}

Axial blower connection in 2AD100/2AD104 (air flow B=>A) and radial blower conn. in 2AD100/2AD104

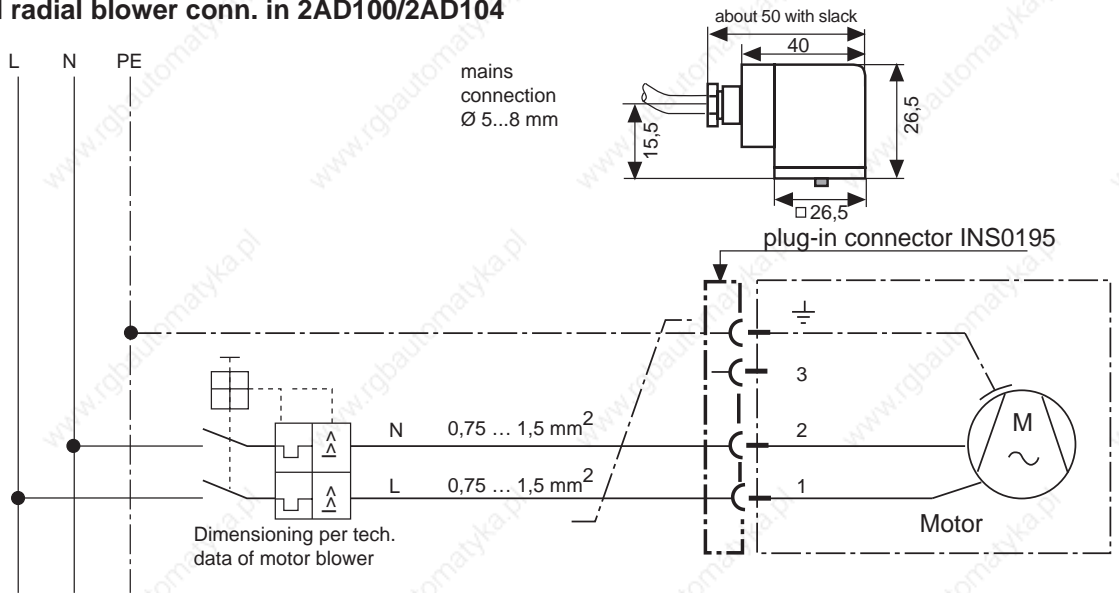

Allowable mains voltage

AC 230 V ±10%, 50...60 Hz :	2AD 100	••••••••••	1	••••••••••	
	2AD 100	••••••••••	6	••••••~•••••	
	2AD 100	••••~•••••	7	••••••~•••••	
	2AD 100	••••••••••	8	••••~•••••	
AC 115 V ±10%, 50...60 Hz :	2AD 100	••••••••••	4	••••~•••••	
	2AD 100	••••~•••••	A	••••~•••••	
	2AD 100	••••~•••••	B	••••~•••••	
	2AD 100	••••~•••••	C	••••~•••••	

LAPAD100

Fig. 14.14: Terminal diagrams for motor blower of 2AD100/2AD104

Motor blower conn. with 2AD132 (terminal box on blower)

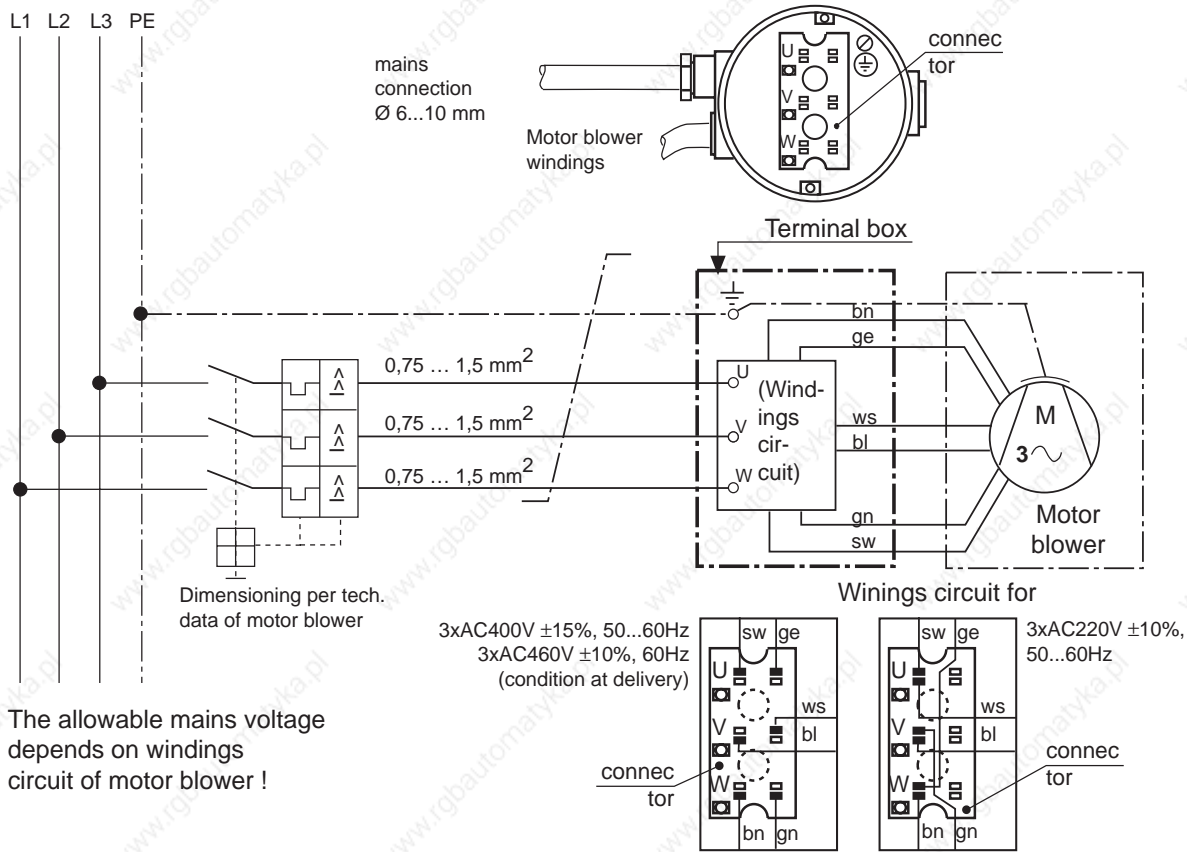

Axial blower connection in 2AD132/2AD134/2AD164 (conn. on blower)

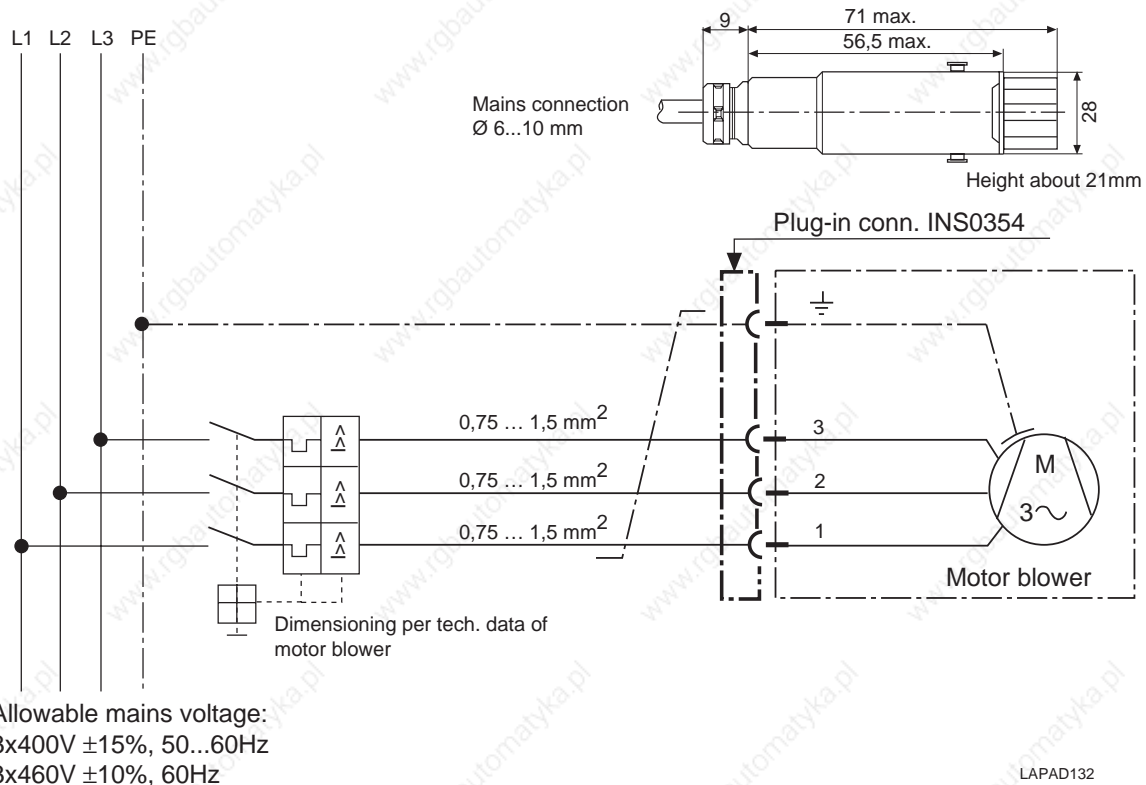

Fig. 14.16: Terminal diagrams for motor blower of 2AD132/-134/-164

14. Electrical connections

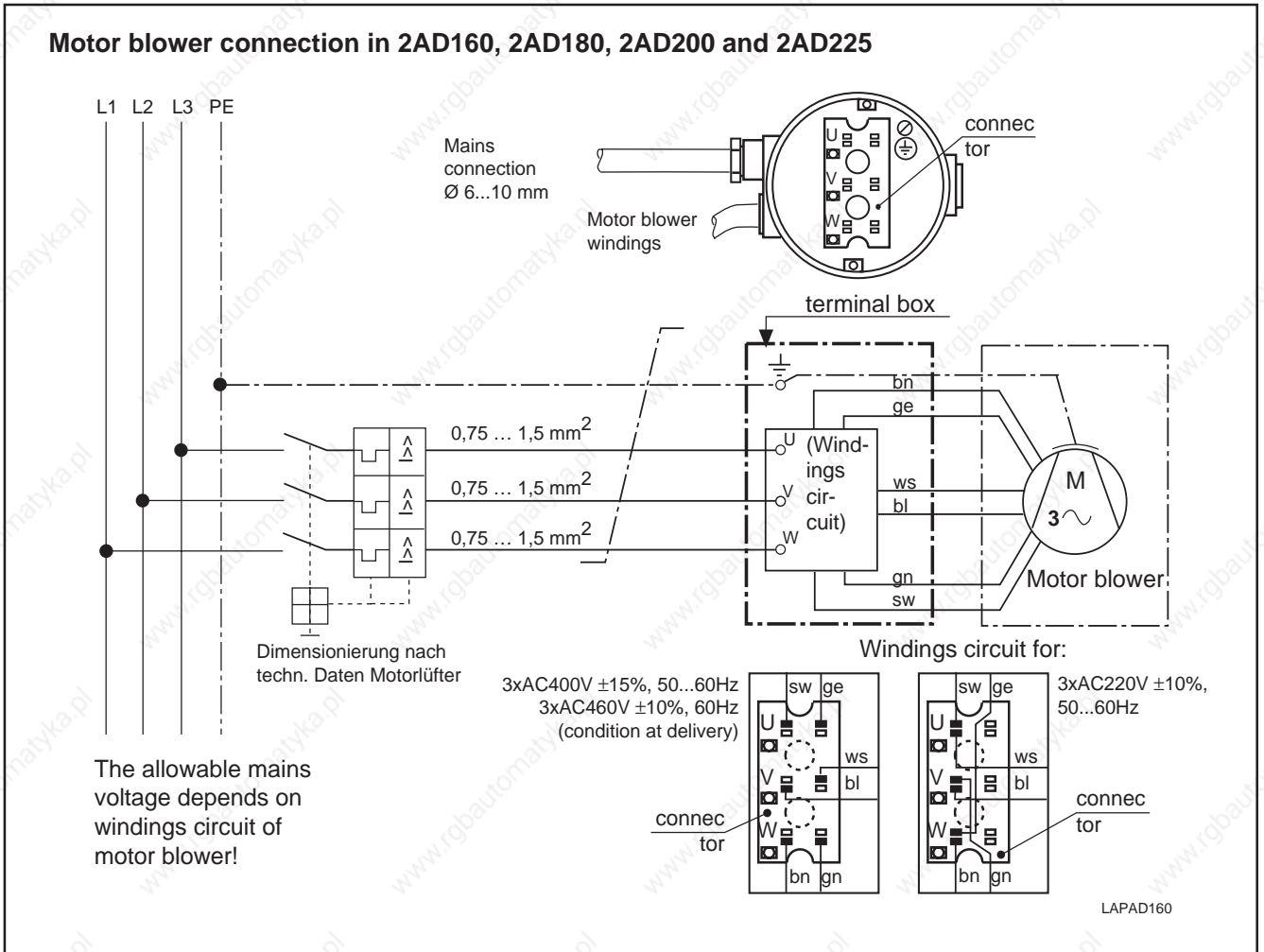

Fig. 14.17: Terminal diagrams for motor blower of 2AD160/-180/-200/-225

14.4 Motor feedback connection

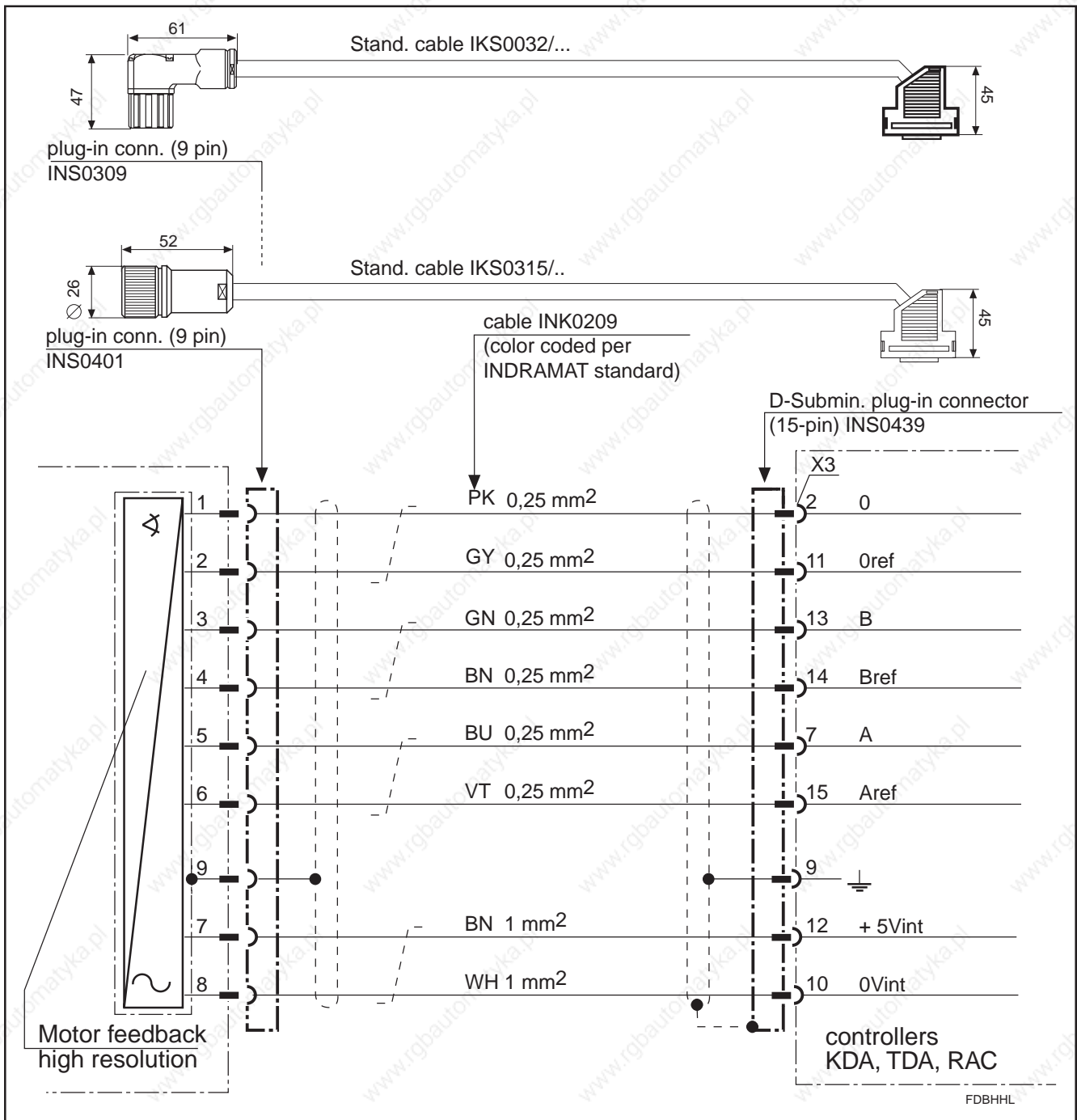

Fig. 14.18: Terminal diagrams for high-resolution motor feedback ("3") on KDA/TDA/RAC

14. Electrical connections

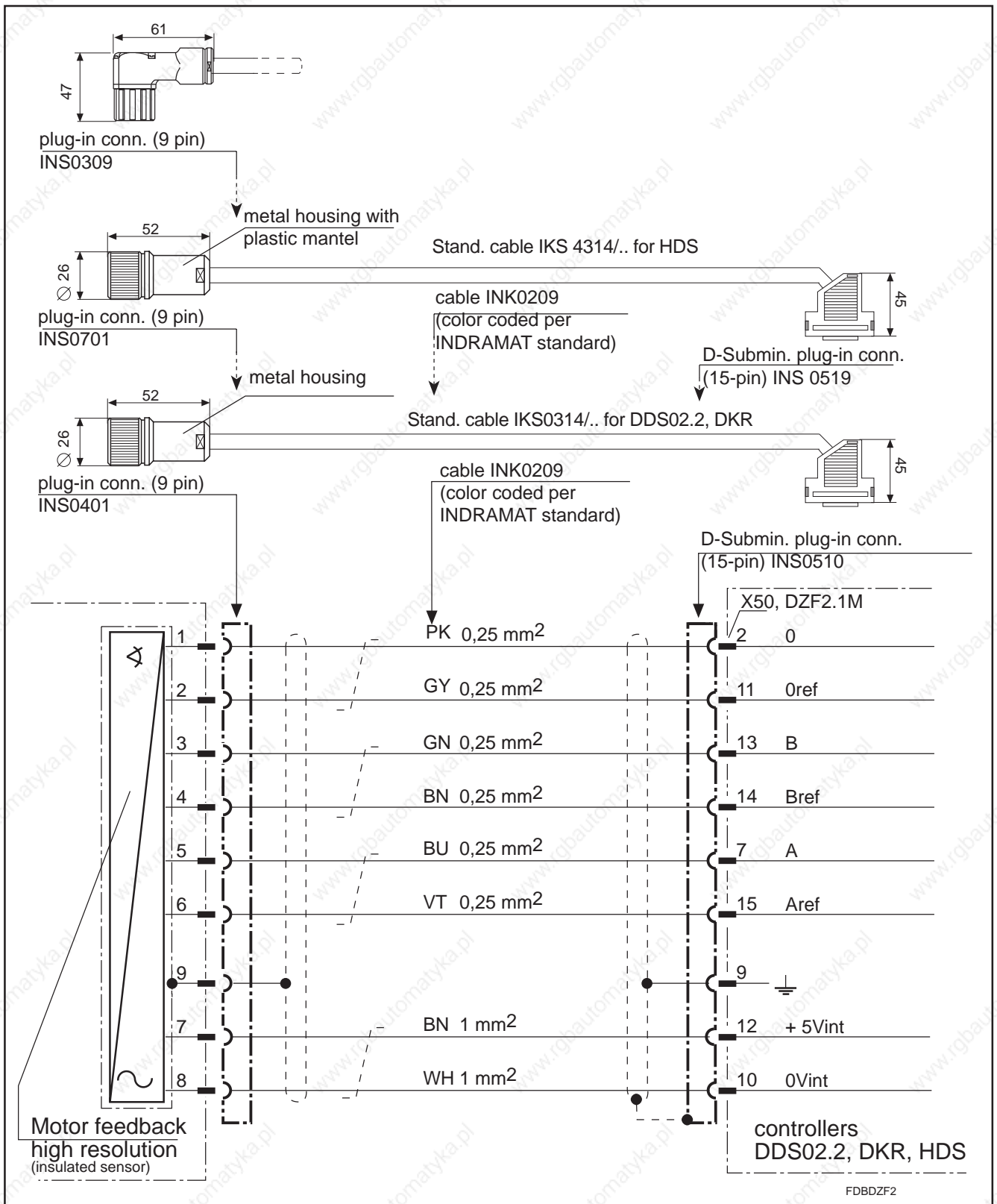

Fig. 14.19: Terminal diagrams for high-resolution motor feedback ("3") on DDS02.2/DKR/HDS

14. Electrical connections

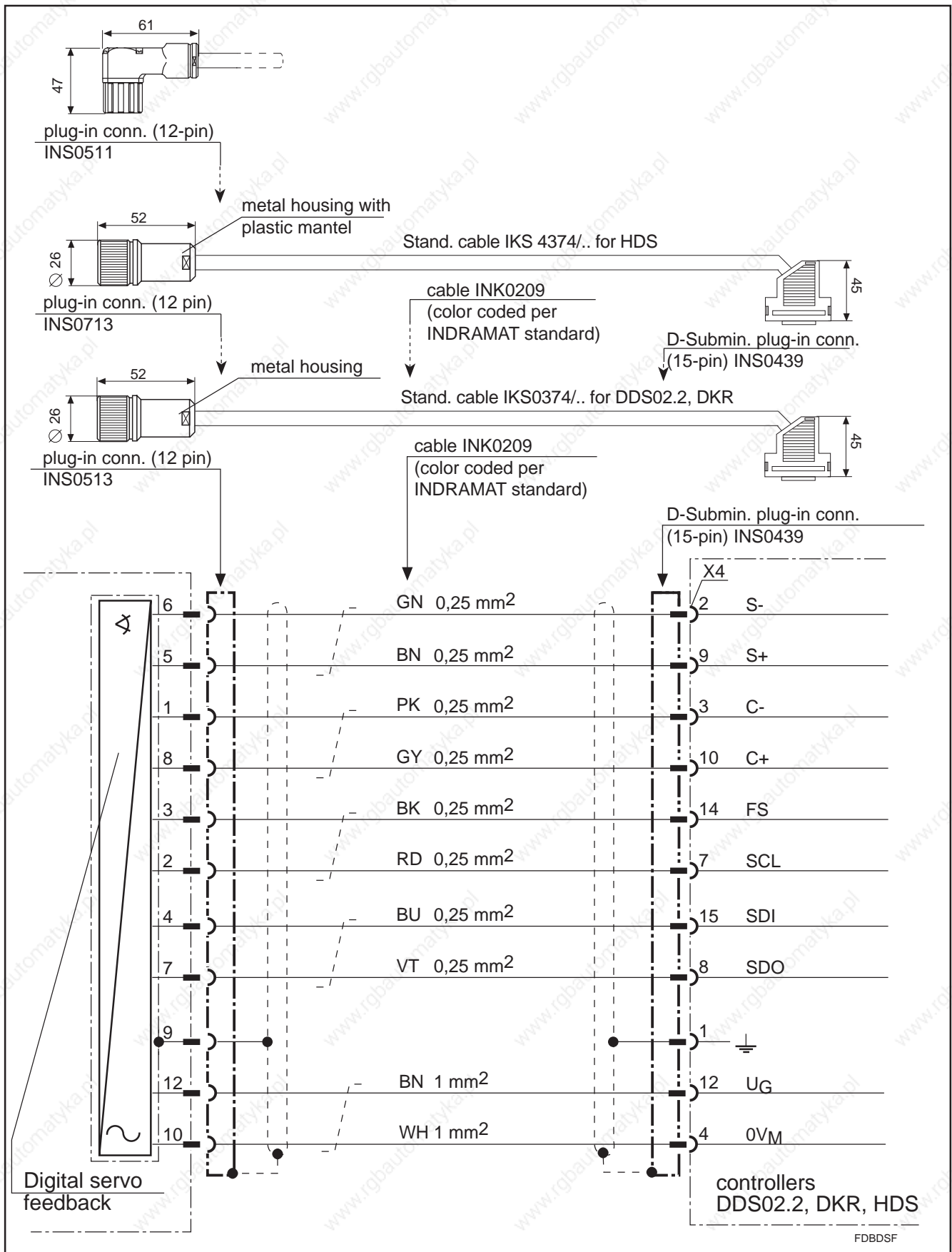

Fig. 14.20: Terminal diagrams for high-resolution motor feedback ("6","7") on DDS02.2/DKR/HDS

14.5 Type Designations

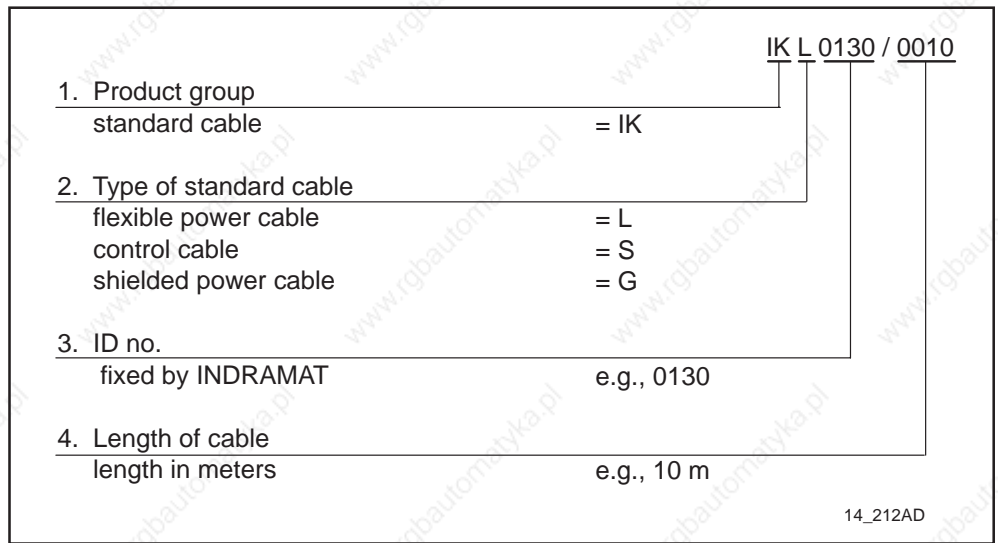

Fig. 14.21: Type designation of standard cables

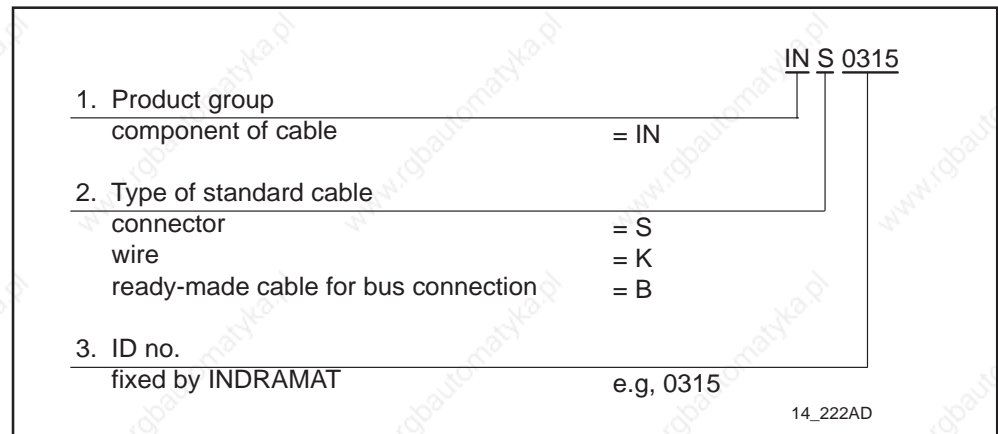

Fig. 14.22: Type designation of components of standard cables

15. State of Delivery

The merchandise is packed onto a pallet or in a carton (2AD100) at the time of delivery.

Pallet:

In the case of single item order, the motor is secured against movement with wooden pegs wedged into strategic spots and is further fastened into place with taut metal bands. If several motors are simultaneously delivered, then there will be up to three motors fixed into place on one pallet. These are, in turn, prevented against moving into other with the styrofoam which has been wedged in between them.

A carton is placed over the pallet to protect against any inclement weather and this also fixed firmly into place with taut bands.



ATTENTION!

Tension in bands!

Danger of injury from uncontrolled movements of the taut bands upon removal!

Maintain sufficiently large distance! Remove the metal bands with care!

By carefully opening the metal bands it is possible to unpack the merchandise without causing any damage.

There is a carton on the envelope in which a delivery slip and a sticker indicating information about customer, delivery slip number, consignment and freight company are listed. Unless request, there are no further consignment documents.

16. Identifying the merchandise

There is a single copy of the delivery slip on the carton. The listed contents of the delivery can be distributed over several transport containers. This is specified in the delivery slip or on the freight papers.

The delivery slip specifies the merchandise by name and order designation.

The packaging of the motor has a barcode sticker on it. It helps identify the contents in terms of design and order processing.



Fig. 16.1: Barcode sticker on the packaging of a 2AD132 (Example)

If several motors are in the packaging, then there is a barcode sticker for each motor on the packaging.

The motor itself has a type plate. It is on the front of the air baffle on the right upper hand side (when looking onto motor shaft).

Each motor has two type plates at delivery. The second one is taped over the original one but can be removed.

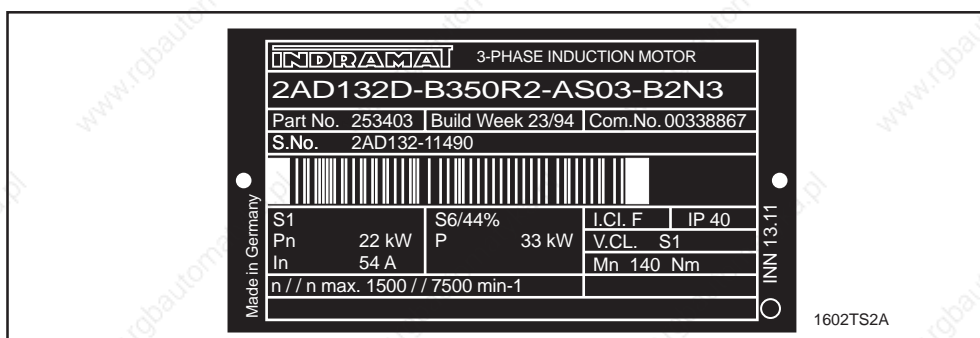

Fig. 16.2: Type plate (Example 2AD132)

17. Storage and Transport

17.1 Notes on Packaging

There are instructions on the packaging regarding transportation, handling of packaging and so on. These must be complied with.



Fig. 17.1: Instructions on storage and transport on the packaging

17.2 Storage



Motor damage and loss of guarantee!

Improper storage can damage the motor. Additionally, all guarantee rights are forfeited.

⇒ Please note the following instructions!

Maintain the following conditions during storage:

- ⇒ Permissible temperature range: -20° C to +80° C.
- ⇒ Motors must be stored dry, dust and shock free.
- ⇒ Store motors in horizontal position.
- ⇒ Do not remove the protective plastic sleeves from the connector housing and output shaft. They protect against moisture and mechanical damage.

18. Safety Guidelines for Electrical Drives

18.1 General Information

- The safety guidelines specified in this document must always be complied with. Any improper handling of the equipment and non-compliance with the warnings can cause property damage, bodily injury or, in extreme cases, lead to death. Indramat assumes no responsibility in the case of damage ensuing from non-compliance with all warnings and guidelines.
- The safe and easy operation of this drive assumes proper transport, storage, mounting and installation as well as careful use and maintenance.
- Only qualified personnel may work on, with or near this equipment. Personnel is qualified if it is trained in mounting, installation and operation of the products as well as is familiar with all warnings and precautionary measures as specified in this document. It is further considered as trained if it can switch current circuits and equipment on and off, to ground and label these. It is equipped with safety equipment and trained in first aid.
- Only use replacement parts specified by the manufacturer.
- Note the safety guidelines and regulations for each application.
- The motors are intended for mounting into machines that will be commercially used.
- Do not start up the machine until it has been ascertained that the machine into which the product has been installed meets EU guidelines 89/392/EEG (machine guides).
- Operation is only permitted if the national EMC guidelines for an application are met. In the EU, EMC guidelines 89/336/EEG are determinative.

18.2 Guidelines on Protection Against Contact with Electrical Parts

If parts conducting voltages exceeding 50 volts are touched, then this could seriously injure personnel. When operating electrical components, certain parts of these inevitably conduct dangerous voltage levels.



High electrical voltage!

Danger to life and limb and serious injury!

- ⇒ Note general construction and safety guidelines when working on high-voltage installations.
- ⇒ Upon completion of installation, check the permanent connections of the protective conductor in all electrical components.
- ⇒ Any operation, even for measuring or test purposes, is only allowed with permanently connected protective conductor in all electrical components.
- ⇒ Prior to accessing electrical parts with voltages exceeding 50 volts, remove electrical components from network or power source. Secure against being switched back on.
- ⇒ Wait the five minutes discharge time after switching the power off before accessing the motors.
- ⇒ Do not touch the electrical connecting points of the components if power is on.
- ⇒ Cover sections conducting power to avoid contact before switching the unit back on.
- ⇒ Protection against indirect contact must be implemented (per DIN EN 50178/Ausg.11.94, section 5.3.2.3).



High leakage current!

Danger of life and limb or serious bodily injury!

- ⇒ Prior to powering up, connect or ground the electrical equipment, each drive controller, power supply unit and the motor to the protective conductor.
- ⇒ The leakage current exceeds 3.5 mA. Units therefore need a permanent connection to the power supply system (per DIN EN 50178/ed. 11.94, section 5.3.2.3).
- ⇒ Prior to startup, even for test purposes, always connect the protective conductor. Otherwise, high voltage levels could occur on the housing.

18.3 Instructions on „Safely-isolated extra low voltages“

The connections and interfaces on the drive components for the signal voltages lie within a voltage range of 5 to 30 volts. These current circuits are a part of the safely-isolated current circuits (safely-isolated low voltages).



High electrical voltages due to incorrect connections!

Danger of life and serious bodily injury!

⇒ To the signal voltage connections of these components only those units, electrical components or lines may be connected that have a sufficiently safe isolation of the connected current circuits that comply with the standards (per DIN EN 50178/ed. 11.94, section 5.3.2.3).

18.4 Instructions on Protection While Handling and Mounting



Danger of serious injury during handling!

Bodily injury caused by pinching, shearing, cutting and impacts!

- ⇒ General construction and safety guidelines on handling and mounting must be noted.
- ⇒ Use suitable mounting and transport devices and install correctly. Use special equipment, if necessary.
- ⇒ Pinching and clamping can be avoided with the use of suitable preventive measures.
- ⇒ If necessary, wear suitable protective clothing (e.g., eye wear, safety shoes, gloves and so on).
- ⇒ Do not stand under hanging loads.
- ⇒ Wipe up all spills immediately.

18.5 Instructions on Protecting Against Dangerous Motions

The causes of dangerous motions can be various:

- a faulty setting from the control
- a software error
- a fault in the components
- wiring or cable fault
- error in the measurand and signal encoders
- problem in the use of the components

This problems can occur immediately after powering up or any time thereafter.



Dangerous movements!

Danger to life, serious bodily injury or property damage!

- ⇒ The monitors in the drive components by and large exclude a malfunction of the the connected drives. In consideration of protection of personnel, however, this should not be exclusively relied upon. Until such time as the built in monitoring devices are active it must be assumed that faulty drive motions will occur the extent of which depend on the nature of the problem and the current operating state. For this reason, personnel protection should be secured by monitors or measures within the installation overall. These are implemented in accordance with the specifics of the installation and after a danger and error analysis has been conducted by the builder of the installation. The safety measures applicable to the installation are included in this concept.
- ⇒ Personnel should not remain within the motional area of the machine. Possible steps to secure unintentional accessing by personnel are:
 - protective fences
 - protective bars
 - covers
 - and light barriers
- ⇒ The fences should have sufficient resistance to take up the maximum possible motional energy of anything intruding.
- ⇒ Emergency stop switch should be easily accessible and within easy reached of the user of the machine. The emergency off setup should be checked for proper functioning prior to commissioning.
- ⇒ Secure against unintentional startups by shutting down the power connection of the drive via the emergency stop loop or use a reliable starting lockout.
- ⇒ Prior to accessing the hazardous area, ensure that the drives are standing still.
- ⇒ Electrical equipment must be completely shut down by means of the main switch and secured against being switched back on during:
 - maintenance and service work
 - when cleaning
 - prior to long operational breaks
- ⇒ Avoid the use of high-frequency, remote control and radio equipment in the vicinity of the electronics of the machine and its lines. If the use of such equipment is unavoidable, then before bringing the machine back up, check the system and installation for any possible malfunctions in all applications. If necessary, run a special EMC check.

19. Assembly and Installation

19.1 General Assembly Instructions

- ⇒ Note the warning and safety instructions outlined in section 18 “Safety Guidelines for Electrical Drives”. This minimizes the risk of accident and avoids damage to the installation and motor.
- ⇒ Carefully conduct these instructions step by step. This ensures that both assembling and disassembling components and parts will be easy and safe.
- ⇒ If the motor is equipped with a labyrinth seal (M02-2AD...) or with a blower base (M01-2AD...) then conduct assembly prior to mounting. The mounting instructions are outlined in the relevant accessories kit.

19.2 Mounting the Motor

- ⇒ Obtain all tools, auxiliary equipment, measuring and testing equipment.
- ⇒ Check to ensure that all parts are clean.
- ⇒ Check whether any parts have visible damage. If they do, then do not mount them.
- ⇒ Make sure that assembly takes place in an environment that is clean, dry, and free of dust.
- ⇒ Make sure that the motor flange is burr free.
- ⇒ If lifting devices are used to mount the motor, then use the rings.



ATTENTION!

**Do not grip the blower unit to pick up the motor!
Danger of ripping off!**

- ⇒ Mount the motor. All dimensions and tolerances must be maintained. The relevant data is specified in the dimensional sheets.

19.3 Connecting the Motor

Once the motor is mechanically mounted, connect it.



DANGER

High electrical voltage!

Touching the motor in areas which conduct voltage is dangerous. Therefore:

- ⇒ Only trained personnel may conduct work on the electrical parts. The use of appropriate tools is absolutely necessary.
- ⇒ Before commencing work, switch power to the machine off and secure the mains switch against being switched back on unintentionally or otherwise.
- ⇒ Before commencing work, check whether there is any residual power in the machine and use special tools to do so (e.g., from capacitors, etc.). Wait discharge time.



Injury to personnel or property damage possible!

Disconnecting or connecting voltage-conducting lines can trigger unpredictable dangerous situations or cause property damage. Therefore:

- ⇒ Connect or disconnect all plug-in connections only if there are dry and no power is present.
- ⇒ All plug-in connections must be firmly in place while the machine is in operation.



Danger of short circuit caused by coolant or greases!

A short-circuit of voltage-conductive lines can trigger unpredictable dangerous situations or cause serious property damage. Therefore:

- ⇒ Cover open connections of power lines during installation or when replacing drive components with protective caps, particularly if the possibility of contamination by coolant or grease exists.

Terminal diagrams from INDRAMAT should exclusively be used to put circuit diagrams of the installation together!

- ⇒ Connect the motor as per the installation circuit diagram of the manufacturer of the machine.

Power connector

When connecting a power connector with bajonet joint (2AD104, -134, -164) please proceed as follows:

- ⇒ Set the power connector on the bajonet thread of the connective housing into the correct position.
- ⇒ Manually turn the power connector until it has audibly clicked into the final position (this is visible if the red dot is opposite the red triangle).

When connecting a power connector with thread (2AD100, -101, -132), proceed as follows:

- ⇒ Set the power connector on the thread of the connective housing into the correct position.
- ⇒ Pull the power connector manually through. By feeding the cable through, the power connector is gradually brought into its final position.
- ⇒ Tighten until it is manually "firm".

With applications with high vibration and shock loads it is advisable to secure the power connector with a bonding agent before removing.

Motor feedback

To connect the digital servo feedback, it is necessary with 2AD132, 160, 180, 200, 225 to remove a section the blower housing which is adjacent to the motor feedback cable leadthrough!

20. Servicing Guidelines

20.1 Maintenance

It is necessary to regularly (no later than one year)

- to clean the motor of excessive dust, chips or similar,
- to check the function of surface motor blower,
- to check air circulation of any surface cooling system.

20.2 Contacting Customer Service

To quickly and effectively eliminate faults, the Service Hotline is available.

⇒ Prior to calling, make a note of the following:

- type data of the drive controller and motor involved
- fault conditions
- fault and diagnostic displays (if present)

The Service-Hotline can be reached

Monday through Friday	7 - 23 CET
Saturday	8 - 20 CET
Sundays and holidays	9 - 19 CET

at

0171 - 333 882 6 **or** 0172 - 660 040 6.

⇒ If you return the motor, then copy the repair slip, fill it out and include it with the return.

⇒ If motors are air-cooled, then transport the motors only after all coolants have been removed. There otherwise exists the danger of the coolant freezing and damaging the coolant lines.

⇒ Include the fault report in the machine documentation, or a copy thereof, so that the user of the machine can implement it in the event of another repair.

This will facilitate repairs and help locate application-specific problems quickly.

20.3 Repair Card

REPAIR CARD for INDRAMAT equipment and components			
Name:		Co./loc.:	Date:
If single parts replaced, then part designation:		SN:	Del. cons. no.:
		SN:	Del. date:
Mach. manuf.:	Type	Mach. no.:	Commissioning date:
Fault in axis:	<input type="checkbox"/> horizontal <input type="checkbox"/> vertical <input type="checkbox"/>	Ref. time:	Date of fault:
Problem: Fault _____ _____ <input type="checkbox"/> always present <input type="checkbox"/> occurs sporadically <input type="checkbox"/> occurs after approx. hrs. <input type="checkbox"/> occurs after vibrations <input type="checkbox"/> temperature-dependent <input type="checkbox"/> other * _____ * _____ * _____		Add. notes: (e.g., LED diagnostics, fault message on displ.) _____ _____ _____ _____ _____ _____	
		Cause: <input type="checkbox"/> unknown <input type="checkbox"/> terminal fault <input type="checkbox"/> ext. short-circuit <input type="checkbox"/> mech. damage <input type="checkbox"/> loose wiring/line <input type="checkbox"/> other * _____ * _____ * _____	
Additional notes			
General information: <input type="checkbox"/> no function <input type="checkbox"/> drive not running smooth <input type="checkbox"/> uncontr. drive movements <input type="checkbox"/> fault in one direction only <input type="checkbox"/> supply fuse blown <input type="checkbox"/> other		Additional problems: <input type="checkbox"/> problem with mechanics <input type="checkbox"/> mains failure <input type="checkbox"/> control unit failure <input type="checkbox"/> motor failure <input type="checkbox"/> break in failure <input type="checkbox"/> other	
		Drive, supply unit, amplifier, mains: <input type="checkbox"/> control volt. fault <input type="checkbox"/> mains failure, fuse F <input type="checkbox"/> blower def. <input type="checkbox"/> bleeder res. def. <input type="checkbox"/> power supply fault <input type="checkbox"/> bolt torn off <input type="checkbox"/> other	
Control unit <input type="checkbox"/> no function <input type="checkbox"/> no display <input type="checkbox"/> no command value output <input type="checkbox"/> diagnostics <input type="checkbox"/> dim. offset in direction <input type="checkbox"/> E-stop loop interrupt <input type="checkbox"/> pos. control loop won't close <input type="checkbox"/> program seq. fault <input type="checkbox"/> aux. func. int. fault (outputs) <input type="checkbox"/> acknowledgements not acc. (inputs) <input type="checkbox"/> other _____ _____ _____		Motor <input type="checkbox"/> defective <input type="checkbox"/> thermocouple <input type="checkbox"/> defective brake <input type="checkbox"/> defective blower <input type="checkbox"/> defective feedback <input type="checkbox"/> defective speed <input type="checkbox"/> enc. signal <input type="checkbox"/> defective BLC signal <input type="checkbox"/> ground short-circuit <input type="checkbox"/> overheating <input type="checkbox"/> other _____ _____ _____ _____	
		Remarks: _____ _____ _____ _____ _____ _____	
		PIRepBegI	

Fig. 20.1: Repair card

21. Index

A

Assembly and Installation 125

B

Barcode sticker 119

Blower base 97

C

Connecting the Motor 125

Construction principle 99

Contacting Customer Service 127

D

Dangerous movements 124

G

General Assembly Instructions 125

Guidelines on Protection Against Contact with Elec 122

H

High leakage current 122

Holding torque 69

I

Identifying the merchandise 119

Instructions on Protecting Against Dangerous Motio 123

Instructions on Protection While Handling and Moun 123

L

Labyrinth seal 99

Lubricant consumption 68

M

Maintenance 127

Motor blower 69

Motor power connections 101

Mounting the Motor 125

N

Nominal conn. voltage 69

Nominal current 69

Notes on Packaging 120

P

Permissible shaft load 68

Power connector 126

R

Repair Card 128

S

Safely-isolated extra low voltages 123

Safety guidelines 121

Safety Guidelines for Electrical D 121

Service-Hotline 127

Servicing Guidelines 127

State of Delivery 118

Storage and Transport 120

T

Technical data of motor blower 93

Type Designations 117

Type plate 119

