

FST Series

Thin Film Temperature Sensor



The FST series design positions the contact surfaces on the side with the active measuring layer. This design produces a sensor in position for face-down mounting. This mounting optimizes current trends in the 'adhesion instead of soldering' electronics sector. Using conductive adhesives provides reliable and cost-effective connection to the circuit board and is an alternative to the conventional reflow or wave soldering. The FST series is available in 2 tolerance classes, 0.12% and 0.24% per the DIN EN 60751 specification. Both tolerance classes are available in the three resistance levels of the FST series.

SERIES SPECIFICATIONS

Model	Nom. Resistance (ohms)	Tolerance Class
FST08-B-100E	100	B
FST08-2B-100E	100	2B
FST08-B-500E	500	B
FST08-2B-500E	500	2B
FST08-B-1K0E	1000	B
FST08-2B-1K0E	1000	2B

Other tolerances and values of resistance are available on request.
Resistance taken at 0°C

DIMENSIONS

(mm)

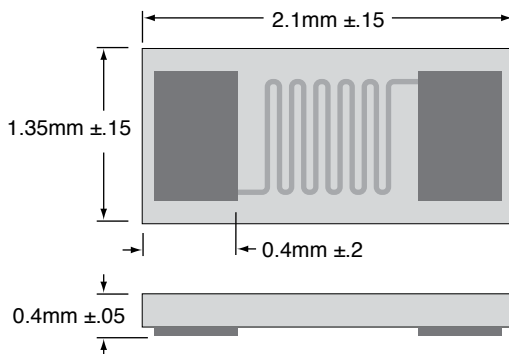

CHARACTERISTICS

Specification	DIN EN 60751
Tolerance	Class B (R0: ± 0.12 %), Class 2B (R0: ± 0.24 %)
Temperature range	-50 °C to 170 °C
Temp. coefficient	TCR = 3850 ppm/K
Contact	AgPd metallising in thick-film technology
Long-term stability	R ₀ drift ≤ 0.06 % after 1000 h at 170°C
Ambient conditions	Use unprotected only in dry environments
Insulation resistance	> 100 MW at 20°C; > 2 MW at 170°C (glass cover)
Measuring current	100 W: 0.3 to 1.0 mA 500 W: 0.1 to 0.7 mA 1000 W: 0.1 to 0.3 mA (self heating has to be considered)
Self heating	0.8 K/mW at 0°C
Reaction time	Flowing water (v = 0.4 m/s): t _{0.5} = 0.10 s, t _{0.9} = 0.25 s Air flow (v = 2 m/s): t _{0.5} = 2.5 s, t _{0.9} = 8.0 s
Processing information	<ul style="list-style-type: none"> • Reflow soldering or wave soldering, e.g. double wave soldering < 8 s / 235° • Also can be mounted using SMD insertion machines with Ag conductive adhesive. • When mounting PCB circuits, the expansion relationship of the sensor and the substrate material must be taken into account.
Storage life	Stored in a nitrogen atmosphere, min. 9 months
Packaging	"Face-down" in blister reel, 1000 pcs / reel

ORDERING INFORMATION

F S T 0 8 - 2 B - 1 0 0 R E

Series Tolerance Resistance value RoHS Compliant