

GSK 218M CNC System

Connection and PLC Manual



广州数控设备有限公司
GSK CNC EQUIPMENT CO., LTD.

✦ The user manual describes all items concerning the operation of this CNC system in detail as much as possible. However, it's impractical to give particular descriptions for all unnecessary and/or unavailable operations on the motor due to the limit of the manual, specific operations of the product and other causes. Therefore, the operations not specified in this manual may be considered impossible or unallowable.



This manual is the property of GSK CNC Equipment Co., Ltd. All rights reserved. It is against the law for any organization or individual to publish or reprint this manual without the express written permission of GSK CNC Equipment Co., Ltd. and the latter reserves the right to ascertain their legal liability.

Company profile

GSK—GSK CNC Equipment Co., Ltd is the largest production and marketing enterprise of the CNC system in China currently. It is the Numerical Control industrial base of South China, and the undertaking enterprise of the 863 national main project Industrialization Support Technology for Medium Numerical Control System as well as one of the 20 basic equipment manufacture enterprises in Guangdong province. It has been taking up the research and development, design and the manufacture of machine CNC system (CNC device, drive unit and servo motor) in recent 10 years. Now it has developed into a large high-tech enterprise integrated with research, education, industry and trade by enhancing the popularization and trade of CNC machine tools. There are more than 1400 staffs in this company that involves 4 doctors, more than 50 graduate students and 500 engineers and more than 50 among them are qualified with senior technical post titles. The high performance-cost ratio products of GSK are popularized in China and Southeast Asia. And the market occupation of GSK's product dominates first and the turnout and sale ranks the top in internal industry for successive 7 years from the year 2000 to 2006, which makes it the largest CNC manufacture base throughout China.

The main products provided by our company includes the NC equipments and devices such as GSK series turning machine, milling machine, machining center CNC system, DA98, DA98A, DA98B, DA98D series full digital stepper motor drive device, DY3 series compound stepper driver device, DF3 series response stepper motor driver device, GSK SJT series AC servo motors, CT-L NC slider and so on. The current national standard (and international standard), industry standard, as well as the enterprise standard (or enterprise internal standard) as a supplementary, are completely implemented in our production process. The capability of abundant technology development and complete production and quality system qualified by us will undoubtedly ensure the reliable product to serve our customers. 24~48 hours technological support and service can be easily and promptly provided by our complete service mechanism and tens of service offices distributed in provinces around China and abroad. The pursuit of "excellent product and superexcellent service" has made the GSK what it is now, and we will spare no efforts to continue to consummate this South China NC industry base and enhance our national NC industry by our managerial concept of "century enterprise, golden brand".

Technological Spot Service

You can ask for spot service if you have the problems that can't be solved by telephone. We will send the engineers authorized to your place to resolve the technological problems for you.

Foreword

Dear user,

It's our pleasure for your patronage and purchase of this GSK GSK218M CNC system made by GSK CNC Equipment Co., Ltd.

The manual is "Connection and PLC Manual".



Accident may occur by improper connection and operation! This system can only be operated by authorized and qualified personnel. Please carefully read this manual before usage!

This manual is reserved by final user.

All specifications and designs herein are subject to change without further notice.

We are full of heartfelt gratitude to you for supporting us in the use of GSK's products.

Warning and precautions

Warning, notice and explanation

This manual contains the precautions to protect user and machine. The precautions are classified as warning and notice by safety, and supplementary information is regarded as explanation. Read the warnings, notes and explanations carefully before operation.

Warning

User may be hurted or equipment can be damaged if operations and steps are not observed.

Notice

Equipment may be damaged if operation instructions or steps are not observed by user.

Explanation

It is used for the supplementary information except for warning and notice.

- Copy right is reserved.

Contents

VOLUME ONE	PROGRAMMING	12
1	SEQUENCE PROGRAM CREATING PROCESS	13
1.1	GSK218M PLC specification	13
1.2	What is a sequence program	13
1.3	Establishment of interface specifications (step 1)	14
1.4	Establishment of ladder diagram (step 2)	14
1.5	Sequence program check (step 3)	14
2	SEQUENCE PROGRAM	15
2.1	Execution process of sequence program	15
2.2	Repetitive cycl	16
2.3	Priority of execution(1 st level, and 2 nd level)	16
2.4	Sequence program structure	17
2.5	Processing I/O (input/output) signals	19
2.5.1	Input signal processing	20
2.5.2	Output singal processing	20
2.5.3	Synchronous processing short pulse signal	20
2.5.4	Difference o fstate of signals between 1 st level and 2 nd level	21
2.6	Interlocking	22
3	ADDRESS	23
3.1	Addresses from Machine tool to PLC (X)	23
3.1.1	Assignment of IO module X address	23
3.1.2	Assignment of MDI panel X address	24
3.2	Address (Y) from PLC to machine tool	25
3.2.1	Assignment of IO module Y address	25
3.2.2	Assignment of IO module Y address	26
3.3	Address (G) from PLC to CNC	27
3.4	Address (F) from CNC to PLC	28
3.5	Internal relay address (R)	29
3.6	Address of keep relay (K)	29
3.7	Addresses(A) for message selection displayed on CRT	29
3.8	Address of meter (C)	30
3.9	Meter preset address(DC)	30
3.10	Timer addresses (T)	30
3.11	Addresses of timer preset value (DT)	30
3.12	Address of data table (D)	31
3.13	Lable address (L)	31
3.14	Subprogram numbers (P)	31
4	PLC BASIC INSTRUCTION	32
4.1	RD, RD.NOT, WRT, WRT.NOT	33
4.2	AND, AND.NOT instructions	33
4.3	OR, OR.NOT instructions	34
4.4	OR. STK instruction	34

4.5	AND.STK instruction.....	35
5	PLC FUNCTIONAL INSTRUCTIONS	36
5.1	END1 (1 st level sequence program end)	37
5.2	END2 (2 nd level sequence program end)	37
5.3	CALL (call subprogram)	37
5.4	SP (Subprogram)	38
5.5	SPE (subprogram end)	38
5.6	SET (set)	39
5.7	RST (reset)	39
5.8	JMPB (label jump)	40
5.9	LBL (Label)	40
5.10	TMR (timer)	41
5.11	CTR (binary counter)	42
5.12	DEC (binary decode)	43
5.13	COD (binary code conversion)	44
5.14	COM (common line control).....	46
5.15	COME (common line control end).....	47
5.16	ROT (Binary rotation control)	48
5.17	SFT (shift register)	50
5.18	DIFU (rising edge check)	51
5.19	DIFD (falling edge check)	52
5.20	COMP (binary comparison)	53
5.21	COIN (concidence check)	54
5.22	MOVN (transfer of data)	55
5.23	XMOV (Binary index data transfer)	56
5.24	DSCH (binary data search)	57
5.25	ADD (addition)	58
5.26	SUB (binary subtraction)	60
5.27	ANDF (logical and)	61
5.28	ORF (logical or)	62
5.29	NOT (logical not)	63
5.30	EOR (exclusive or)	64
6	LADDER WRITING LIMIT.....	66
VOLUME TWO	FUNCTION.....	67
1	CONTROLLED AXIS	68
1.1	Outputting of movemtn state of an axis.....	68
1.2	Servo ready signal.....	69
1.3	Servo OFF signal.....	69
1.4	Mirror image.....	71
1.5	Position switch.....	73
2	PREPARATION FOR OPERATION	74
2.1	Emergency stop.....	74
2.2	CNC ready signal.....	74
2.3	CNC overtravel signal.....	75

2.4	Alarm signal.....	76
2.5	Machine ready signal.....	77
2.6	Interlock activation.....	77
2.7	Mode selection.....	78
2.8	Status output signal.....	78
2.9	VRDY OFF alarm ignore signal.....	79
2.10	Abnormal load check.....	79
3	MANUAL OPERATION	81
3.1	JOG feed/incremental feed.....	81
3.2	MPG(Handwheel) feed.....	82
3.3	MPG interruption.....	83
4	REFERENCE POINT RETURN	84
4.1	Manual reference point return.....	84
5	AUTOMATIC OPERATION.....	88
5.1	Cycle start/feed hold.....	88
5.2	Reset.....	91
5.3	Testing a program.....	93
5.3.1	Machine tool lock.....	93
5.3.2	Dry run.....	94
5.3.3	Single block.....	95
5.4	Optional block skip.....	96
5.5	Program restart.....	97
6	INTERPOLATION FUNCTION	98
6.1	Thread cutting.....	98
7	FEEDRATE CONTROL	99
7.1	Rapid traverse rate.....	99
7.2	Advanced preview control.....	99
7.3	In-position check.....	100
7.4	Error detect.....	101
7.5	Override.....	102
7.5.1	Rapid traverse override.....	102
7.5.2	Feedrate override.....	102
7.5.3	Override cancel.....	103
8	MISCELLANEOUS FUNCTION (M, S, T FUNCTION).....	104
8.1	Miscellaneous function.....	104
8.2	Auxiliary function lock.....	109
8.3	High-speed M/S/T interface.....	110
9	SPINDLE SPEED FUNCTION.....	113
9.1	Spindle speed control mode.....	113
9.1.1	Gear spindle.....	113
9.1.2	Analog spindle.....	114
9.2	Spindle speed arrival signal.....	115
9.3	Constant surface speed control.....	116
9.4	Rigid tapping.....	117

10 TOOL FUNCTION	119
10.1 <i>T instruction executing tool change.....</i>	<i>119</i>
10.2 <i>Tool life management.....</i>	<i>119</i>
11. PROGRAMMING INSTRUCITON	123
11.1 <i>Custom macro program</i>	<i>123</i>
11.2 <i>Canned cycle.....</i>	<i>126</i>
11.3 <i>Metric/Inch conversion.....</i>	<i>127</i>
11.4 <i>Small hole peck drilling cycle</i>	<i>128</i>
12 DISPLAY/SET	129
12.1 <i>Clock Function</i>	<i>129</i>
12.2 <i>Displaying operation history.....</i>	<i>129</i>
12.3 <i>Help function.....</i>	<i>129</i>
12.4 <i>Operation hour and parts count display.....</i>	<i>129</i>
12.5 <i>Memory protection key.....</i>	<i>130</i>
13 MEASUREMENT	132
13.1 <i>Skip function.....</i>	<i>132</i>
13.2 <i>Torque limit skip.....</i>	<i>133</i>
APPENDIX	134
Signal list (During order of address).....	134
VOLUME THREE OPERATION	137
1 PLC INTERFACE DISPLAY	138
1.1 <i>Automatic operation when GSK218M PLC power on.....</i>	<i>138</i>
1.2 <i>INFO interface display.....</i>	<i>138</i>
1.2.1 <i>INFO interface.....</i>	<i>138</i>
1.2.2 <i>PLCGRA interface.....</i>	<i>139</i>
1.2.3 <i>PLCPAR interface</i>	<i>139</i>
1.2.4 <i>PLCGND interface</i>	<i>140</i>
2 PLC PROGRAMMING OPERATION.....	142
2.1 <i>General.....</i>	<i>142</i>
2.2 <i>Basic instruction(B. INST).....</i>	<i>143</i>
2.3 <i>Operations of ladder.....</i>	<i>144</i>
2.4 <i>Function instruction.....</i>	<i>146</i>
2.5 <i>Instruction list.....</i>	<i>148</i>
2.6 <i>Edit instruction.....</i>	<i>149</i>
2.7 <i>PLC operation step.....</i>	<i>150</i>
3 PLC ADDRESS, PARAMETER SETTING	151
3.1 <i>Counter.....</i>	<i>151</i>
3.2 <i>Timer.....</i>	<i>152</i>
3.3 <i>Data list.....</i>	<i>153</i>
3.4 <i>Keep relay.....</i>	<i>154</i>
3.5 <i>F address corresponded to M function.....</i>	<i>155</i>
VOLUME FOUR CONNECTION	157

1	SYSTEM STRUCTURE AND INSTALLATION.....	158
1.1	System composition.....	158
1.2	System installtion & connection.....	158
1.3	CNC system installation dimension.....	159
2	DEVICE CONNECTION.....	162
2.1	CNC external connection.....	162
2.2.1	System interface.....	162
2.2.2	Interface signal list.....	163
2.2.3	Signal specification.....	163
2.2.4	Cable connection.....	166
2.3	RS232 standard serial interface.....	167
2.4	MPG(handwheel), hand unit connection.....	167
2.4.1	Interface signal list.....	167
2.4.2	Interface signal.....	167
2.5	Spindle unit connection.....	168
2.5.1	Interface signal list.....	168
2.5.2	Interface signal:.....	168
2.6	Power supply interface.....	168
3	MACHINE CONTROL I/O INTERFACE.....	169
3.1	Interface signal list.....	169
3.2	Input interface.....	169
3.2.1	Input interface method.....	169
3.2.2	Input signal interface definition.....	170
3.3	Output signal.....	172
3.3.1	Output interface method.....	172
3.3.2	Ouput signal interface definition.....	173
4	DEBUGGING MACHINE.....	175
4.1	Debug preparation.....	175
4.2	System power on.....	175
4.3	Emergency stop and limit.....	176
4.4	Gear ratio adjustment.....	177
4.5	Backlash compensation.....	178
4.6	Parameter for servo.....	179
4.7	Machine pitch compensation.....	179
4.8	Debugging parameters.....	182
4.8.1	Machine zero return.....	182
4.9	Input/output signal control of spindle CW/CCW.....	183
4.10	Spindle automatic gear change control.....	184
4.11	External cycle start and feed hold.....	186
4.12	Cooling, lubricant and chip removal control.....	186
4.13	Parameters of axis control.....	187
4.14	Parameter for coordinate system.....	188
4.15	Parameter for feedrate.....	188
4.16	Parameters for MDI, display and servo.....	191
4.16	Parameters of MDI, display and edit.....	191

4.17 Parameters for tool compensation..... 194

APPENDIX: 196

Guide for GSK218M matching with ladder..... 196

- 1. Notices of GSK218M matching with turret tool magazine..... 196
- 2. Allocation and definition of PMC IO address, auxiliary relay and register..... 196
- 3. Usage and maintenance of GSK 218M CNC System matching with turret tool magazine 218
- 4. Macro program statement of GSK218M CNC System matching with turret tool magazine 223

Volume one Programming

1 Sequence Program Creating Process

1.1 GSK218M PLC specification

Specifications of GSK218M PLC are as follows:

Specification	GSK218M PLC
Programming method language	Ladder
Number of ladder level	2
1 st level execution period	8ms
Mean processing time of basic instruction	10μs
Program capacity	4700 step
Instruction	Basic instruction +function instruction
Internal relay (R)	0~511 byte
PLC message request (A)	0~31 byte
Keepmemory	
* Timer (T)	0~127 byte
* Meter (C)	0~127 byte
* Data table (D)	0~255 byte
* Keep relay (K)	0~63 byte
* Meter preset value data register (DC)	0~127 byte
* Timer preset value data register (DT)	0~127 byte
Subprogram (P)	0~99
Label (L)	0~99
I/O module (X)	
(Y)	0~63 byte
	0~47 byte

1.2 What is a sequence program

A sequence program is a programm for sequence control of machine tools and other systems.

The program is converted into a format to enable CPU execute encoding and arithmetic processing, and stored into RAM. CPU reads out instructions of the program stored into the memory at the high-speed every instruction and execute the program by arithmetic operation

The sequence program is written firstly from ladder.

1.3 Establishment of interface specifications (step 1)

After deciding the control object specification and calculate the number of input/output signal points, create the interface specification.

For input/output interface signals, see Chapter 4.

1.4 Establishment of ladder diagram (step 2)

Express the control operations decided by 218M ladder diagram. For the timer, meter, etc, which cannot be expressed with the functional instructions.

The edited ladder should be converted into the corresponding PLC instruction to store.

1.5 Sequence program check (step 3)

The sequence program can be checked in two ways:

1) Check by simulator

Instead of the machine, connect a simulator (consisting of lamps and switches). Switch ON/OFF stands for the input signal state of machine, lamp ON/OFF for the output signal state.

2) Actual operation debugging

Debug sequence program through operating the machine. Do measures against the unexpected affairs before debugging.

2 Sequence Program

Since PLC sequence control handled by software and operates on principle difference from a general relay circuit, the sequence control method must be fully understood in order to design PLC sequence program.

2.1 Execution process of sequence program

In general relay control circuit, each relay operates at approximately the same time, in the figure below for example, when relay A operate, the relay D and E operate at approximately the same time (when contacts B and C are off). In PLC sequence control, each relay of circuit operates sequentially. When relay A operates, relay D operates, then relay E (see the below figure). Thus each relay operates in sequence which can be written as a ladder diagram. (programmed sequence).

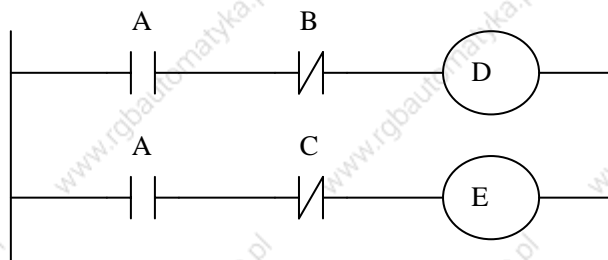

Fig. 2.1(a) circuit example

Fig.(b) and (c) illustrate operations varying from the relay circuit to PLC program.

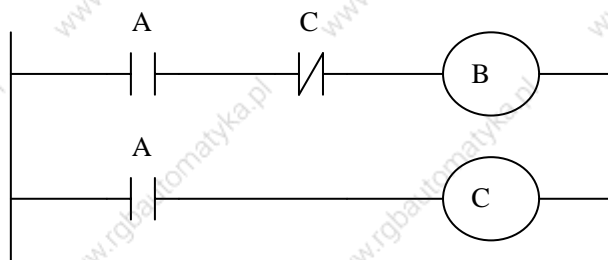

Fig. 2.1(b)

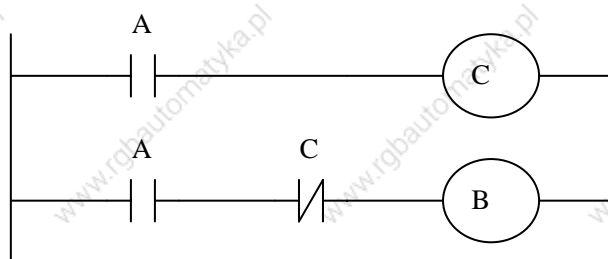

Fig. 2.1(c)

(1) Relay circuit

In Fig. (A) and (B), the operations are the same. Turning on A turns on B and C. Turning on C turns off B.

(2) 218M PLC program

In Fig.(B), as in the relay circuit, turning on A turns on B and C, and after one cycle of the PLC sequence, turns off B. But in Fig.(C), turning on A turns on C, but does not turn on B.

2.2 Repetitive cycle

The sequence program is executed from the beginning of coding to the end of coding of the ladder diagram in the sequence written. When the sequence program ends, the program starts over from the beginning. This is called repetitive operation.

The execution time from the beginning to the end of the ladder diagram is called the sequence processing time. The shorter the process time is, the better the signal response becomes.

2.3 Priority of execution(1st level, and 2nd level)

GSK218M PLC consists of two parts: 1st level sequence part, 2nd level sequence part. They have different execution period.

The 1st level sequence part operates every 4ms, which can operate the short pulse signal with high-speed response).

The 2nd level sequence part operates every $4 \cdot n$ ms. Here n is a dividing number for the 2nd level sequence part. The 2nd level sequence part is divided into n part, and every part is executed every 4ms.

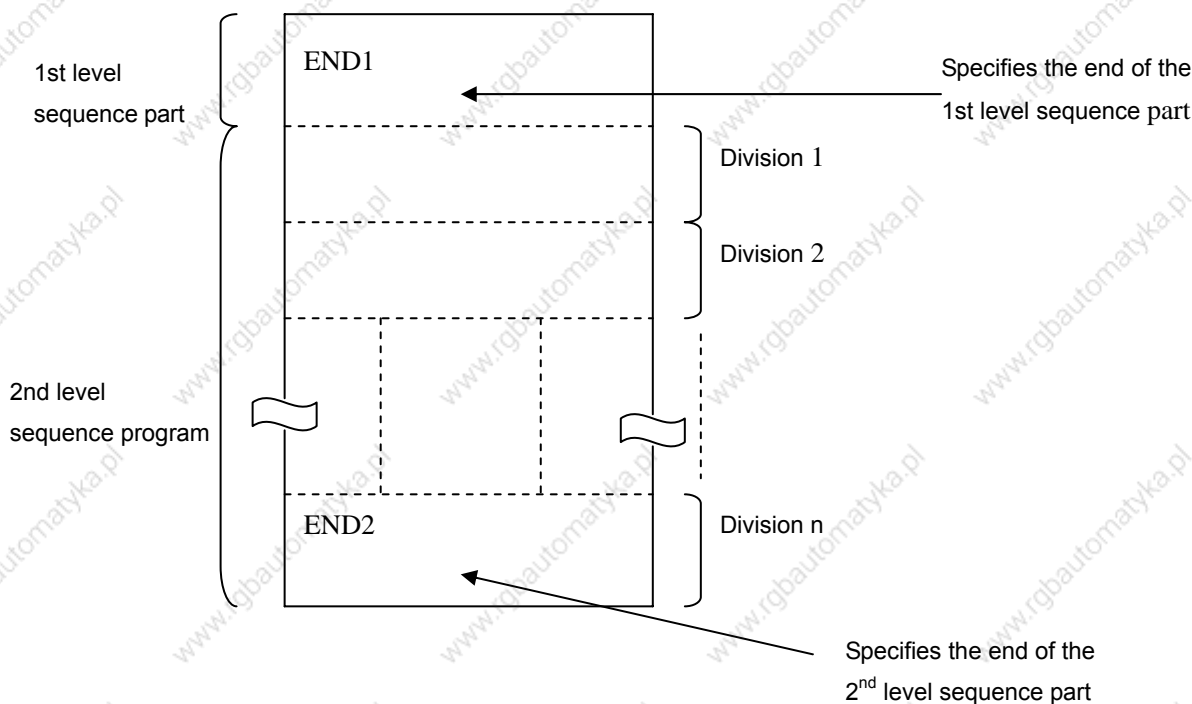

218M PLC is solely executed in PLC-AVR single unit, and the second 2ms of every 4ms is the communication time of CNC reading or writing PLC data.

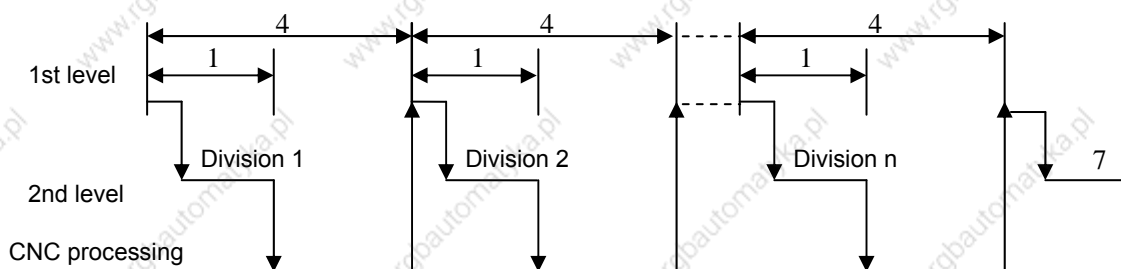

After the last 2nd level sequence part (division n) is executed, the sequence program is executed again from the beginning. Thus, when the dividing number is n, the cycle of execution is 4*n ms. The 1st level sequence operates every 4ms, and the 2nd level sequence every 4*n ms. If the steps of the 1st level sequence is increased, the steps of the 2nd level sequence operating within 4ms becomes less, thereby increasing the dividing number and making the processing time longer. Therefore, it is desirable to program so as to reduce the 1st level sequence to a minimum.

2.4 Sequence program structure

With the conventional PLC, a ladder program is described sequentially. By employing a ladder language that allows structured programming, the following benefits are derived:

1. A program can be understood and developed easily
2. A program error can be found easily.

3. When an operation error occurs, the cause can be found easily.

Three major structured programming capabilities are supported:

1) Subprogram

A subprogram can consist of a ladder sequence as the processing unit.

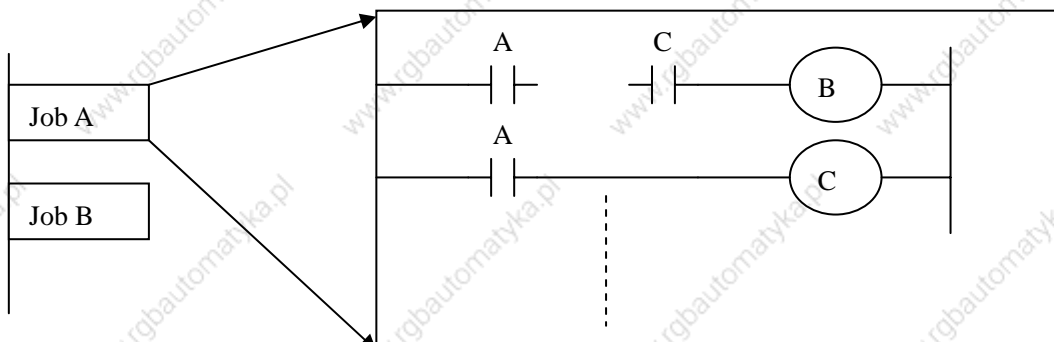

2) Nesting

Ladder subprograms established are combined to structure a ladder sequence.

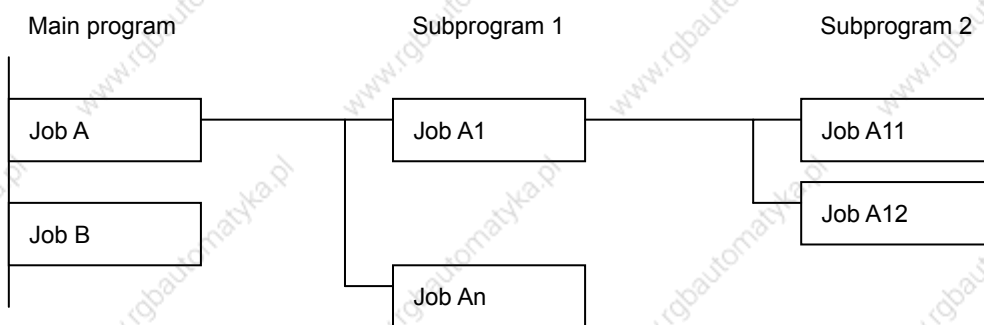

3) Conditional branch

The main program loops and checks whether conditions are satisfied. If a condition is satisfied, the corresponding subprogram is executed. If the condition is not satisfied, the subprogram is skipped.

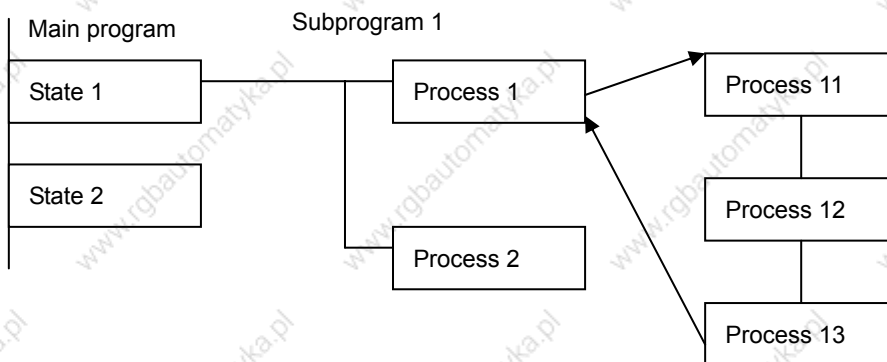

2.5 Processing I/O (input/output) signals

Input signal processing:

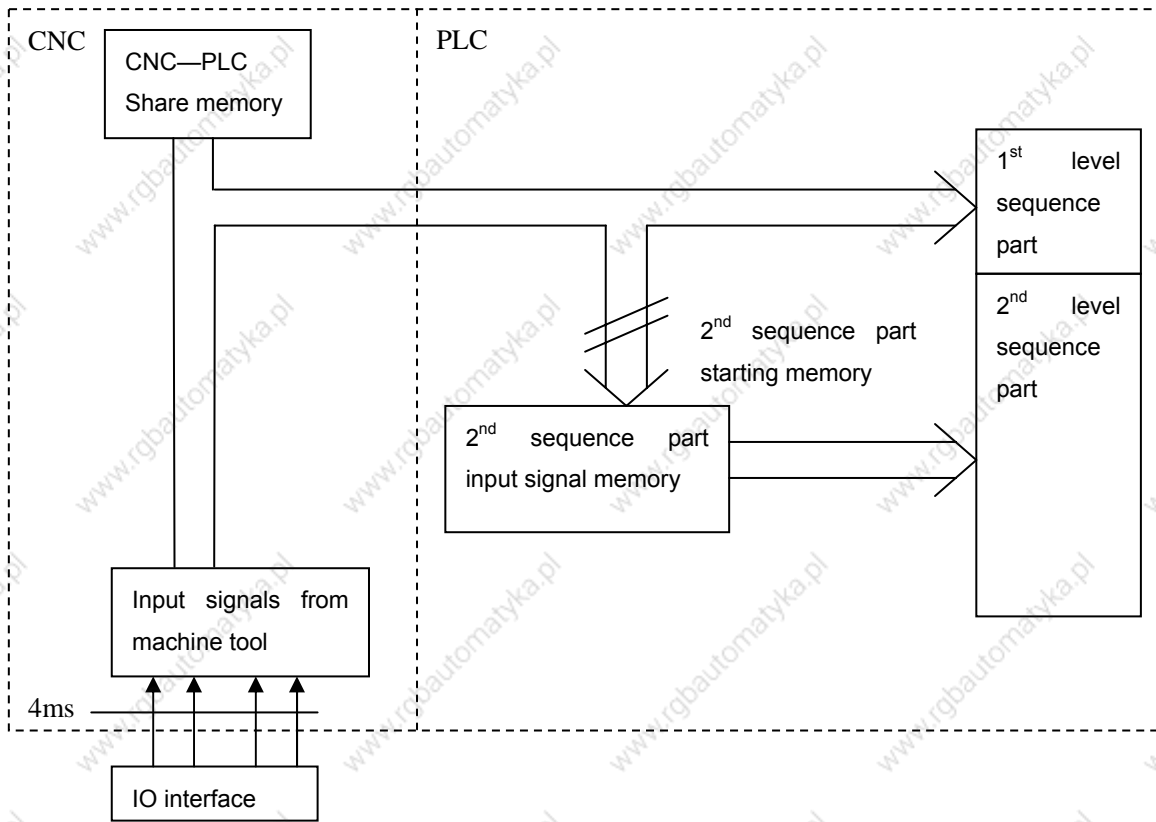

Output signal processing:

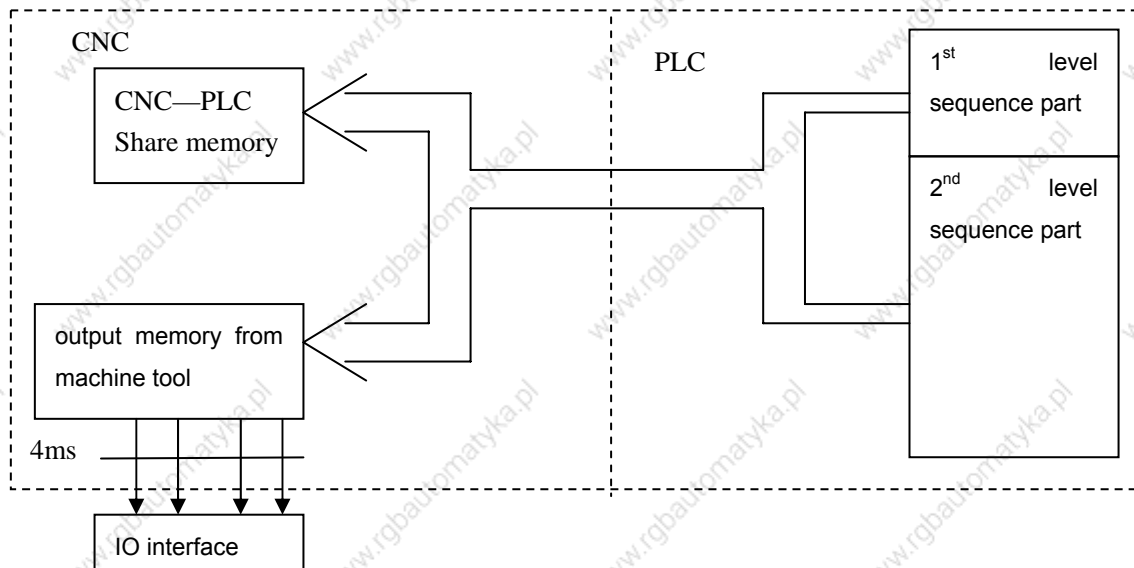

2.5.1 Input signal processing

(1) Input memory of NC

The input signals from NC are loaded in memory of NC and are transferred to the PLC at intervals of 4ms. Since the 1st level sequence part directly refer to these signal and process operations.

(2) Input signal memory to machine tool

The input signal memory stores signals transferred from the machine tool at intervals of 2ms period. Since the 1st level sequence part directly refer to these signal and process operations.

(3) 2nd level input signal memory

The 2nd level input signal memory is also called as 2nd level synchronous input signal memory. The stored signals are processed by the 2nd level sequence part. State of the signals set this memory synchronizes with that of 2nd level sequence part.

Input memory Signals from NC and machine tool are transferred to the 2nd level input signal memory only at the beginning of execution of the 2nd level sequence part. Therefore, the state of the 2nd level synchronous input signal memory does not change from the beginning to end of the execution of the 2nd level sequence part.

2.5.2 Output signal processing

(1) NC output memory

The output signals are transferred from the PLC to the NC output memory at intervals of 4ms.

(2) Output signals to machine tool

Output signal to the machine tool from PLC output signal memory to the machine tool.

Note:

The state of the NC input memory, NC output memory, input signals from machine, input/output memory signals to machine can be checked by using the PC self-diagnosis function. The self-diagnosis number specified is the address number used by the sequence program.

2.5.3 Synchronous processing short pulse signal

1st level sequence part is used for processing the short pulse signal. But when it is less than 4ms, namely, when 1st level sequence is executed, the state of input signal may change as follows:

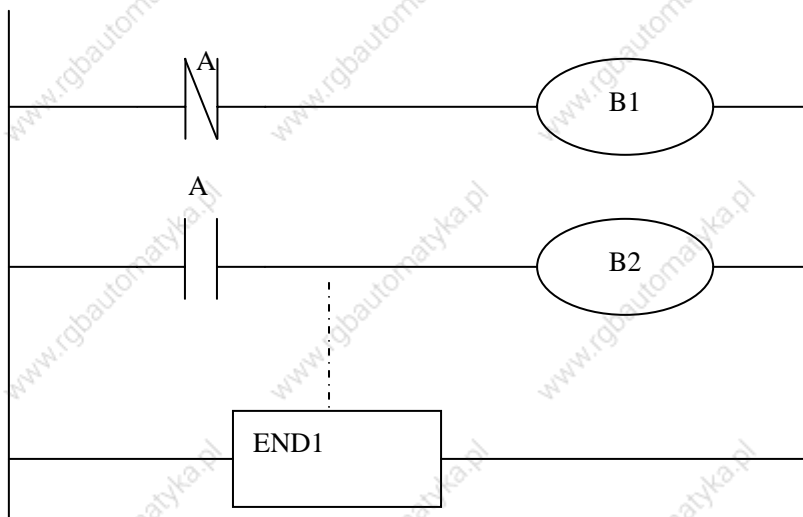

When A=0, and B1=1, A becomes 1, at this time, the next line of ladder is executed, B2=1. B1 and B2 are also 1.

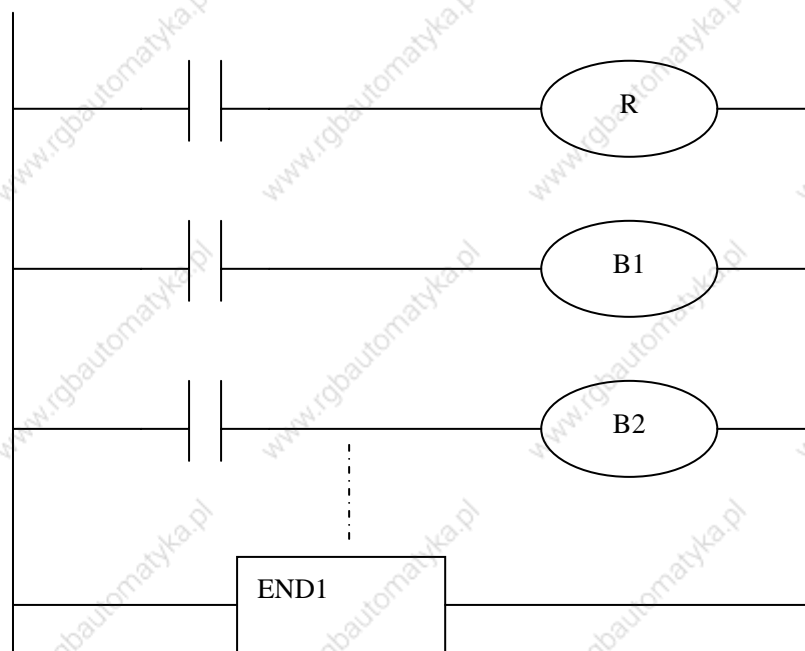

B1 and B2 are not 1 simultaneously after the signal A is processed synchronously by the medium relay.

2.5.4 Difference of state of signals between 1st level and 2nd level

The state of the same input signal may be different in the 1st level and 2nd level sequences. That is, at 1st level, processing is performed using input signal memory and at 2nd level, processing is performed using the 2nd level synchronous input signal memory. Therefore, it is possible for a 2nd level sequence execution at the worst, compared with a 1st level input signal.

This must be kept in mind when writing the sequence program.

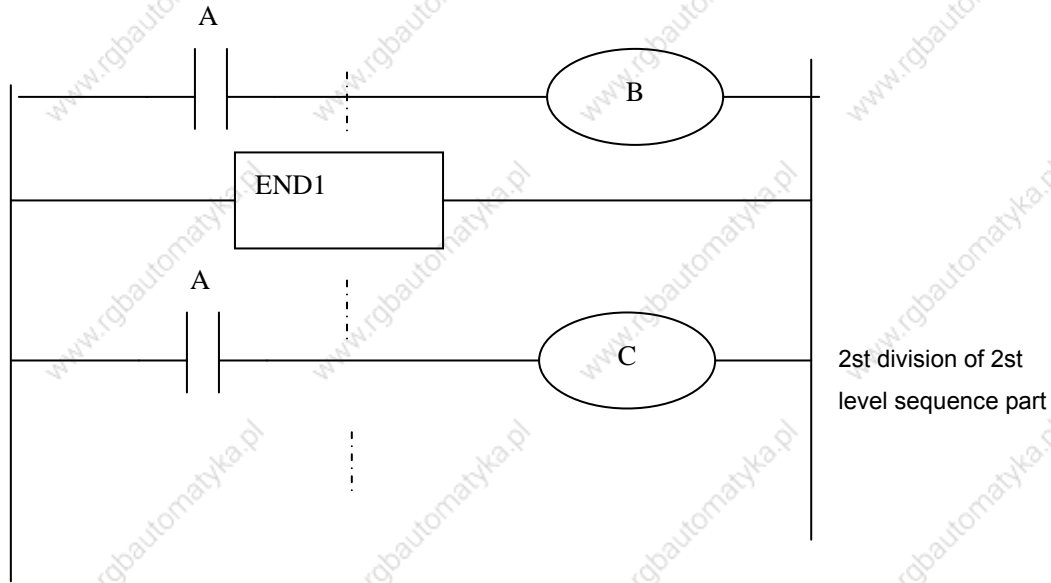

When the processing is 1st 4ms, A=1, and B=1 after 1st sequence part is executed. At the same time, 2nd sequence part is started to execute A=1 is stored to the 2nd sequence part and the 1st division of 2nd sequence part is executed.

When the processing is 2nd 4ms, A=0, and B=0 after 1st sequence part is executed. And then 2nd division of 2nd sequence part is executed, at this time, A is still 1. So C=1.

So, B and C are different.

2.6 Interlocking

Interlocking is externally important in sequence control safety.

Interlocking with the sequence program is necessary. However, interlocking with the end of the electric circuit in the machine tool magnetics cabinet must not be forgotten. Even though logically interlocked with the sequence program (softward), the interlock will not work when trouble occurs in the hardware used to execute the sequence program. Therefore, always provide an interlock inside the machine tool magnetics cabinet panel to ensure operator safety and to protect the machine from damage.

3 Address

An address shows a signal location. Addresses include input/output signals with respect to the machine, the input/output signals with respect to the CNC, the internal relays, the meters, the keep relays, and data table. Each address consists of an address number and a bit number. Its serial number regulations are as follows:

Address regulations:

The address comprises the address type, address number and the bit number in the format as shown below:

X 000 . 6

Type Address number Bit number

Type: including X, Y, R, F, G K, A, D, C, P, L, T

Address number: decimal serial number stands for one byte.

Bit number: octal serial number, 0~7 stands for 0~7 bit of byte of front address number

218M PLC address type is as follows:

Character	Signal description	Length
X	Machine tool→PLC(64 byte)	INT8U
Y	PLC→machine tool (64 byte)	INT8U
F	CNC→PLC(64 byte)	INT8U
G	PLC→CNC(64 byte)	INT8U
R	Internal relay(512 byte)	INT8U
D	Data register (0~255)	
DC	Counter preset data register	
C	Meter (0~127)	
A	PLC message request signal	INT8U
T	Timer (0~127)	
DT	Timer preset data register	
K	Keep relay (64 byte)	INT8U

3.1 Addresses from Machine tool to PLC (X)

X addresses of GSK218M PLC are divided into two:

1. X addresses are assigned to IO input interface of XS43, XS44 and XS45.
2. X addresses are assigned to the input press keys on MDI panel.

3.1.1 Assignment of IO module X address

The addresses are from X0 to X5. Its type is INT8U, 48 types. They are assigned to three IO input

interface of XS 43, XS44 and XS45.

The signal specification of X addresses can be customized by customer according to the actual operation. X addresses are used to connect the machine tool with the ladder. For the initial definition of input address, see Connection.

3.1.2 Assignment of MDI panel X address

The addresses are from X20 to X30, 11bytes. They correspond to the press keys on MDI panel, and their signal definitions cannot be changed by user.

Addresses and press keys are as follows:

Input key on operator panel	PLC address
Edit mode	X20.0
Auto mode	X20.1
MDI mode	X20.2
Machine zero return mode	X20.3
Single step mode	X20.4
Manual mode	X20.5
MPG mode	X20.6
DNC mode	X20.7
Skip	X21.0
Single block	X21.1
Dry run	X21.2
Miscellaneous(M, S, T) lock	X21.3
Machine lock	X21.4
Selection stop	X21.5
Program restart	X21.6
Spindle CW	X22.0
Spindle stop	X22.1
Spindle CCW	X22.2
Spindle negative override	X22.3
Spindle override cancel	X22.4
Spindle positive override	X22.5
Spindle jog	X22.6
Lubrication	X23.0
Cooling	X23.1
Chip removal	X23.2
Cycle start	X23.6
Feed hold	X23.7
Feedrate positive override	X24.0

Feedrate override cancel	X24.1
Feedrate negative override	X24.2
Rapid	X24.7
Rapid F0 / 0.001	X26.0
Rapid 25% / 0.01	X26.1
Rapid 50% / 0.1	X26.2
Rapid 100% / 1	X26.3
Manual feed axis +X	X27.0
Manual feed axis +Y	X27.1
Manual feed axis +Z	X27.2
Manual feed axis +Th4	X27.3
USER1	X27.4
Manual feed axis -X	X28.0
Manual feed axis -Y	X28.1
Manual feed axis -Z	X28.2
Manual feed axis -Th4	X28.3
USER2	X28.4
USER3	X28.7
Spindle orientation	X29.0
Tool magazine zero return	X29.1
Tool clamp/ release	X29.2
Tool magazine CW	X29.3
Tool magazine CCW	X29.4
tool infeed	X29.5
tool retraction	X29.6
Tool change manipulator	X29.7
Overtravel release	X30.0

3.2 Address (Y) from PLC to machine tool

Y addresses of GSK218M PLC are divided into two:

1. Y addresses are assigned to IO input interface of XS40, XS41 and XS42.
2. Y addresses are assigned to the indicators on MDI panel.

3.2.1 Assignment of IO module Y address

- a) The addresses are from Y0 to Y5. Its type is INT8U, 48 types. They are assigned to three IO input interface of XS40, XS41 and XS42.

The signal specification of Y addresses can be customized by customer according to the actual operation. Y addresses are used to connect the machine tool with the ladder. For

the initial definition of input address, see Connection.

3.2.2 Assignment of IO module Y address

The addresses are from Y12 to Y19, 8 bytes. They correspond to the indicators on MDI panel, and their signal definitions cannot be changed by user.

Addresses and indicators are as follows:

Output key on operator panel	PLC address
Edit key indicator	Y12.0
Auto key indicator	Y12.1
MDI key indicator	Y12.2
Machine zero return indicator	Y12.3
Single step key indicator	Y12.4
Manual key indicator	Y12.5
MPG key indicator	Y12.6
DNC key indicator	Y12.7
Spindle CW indicator	Y13.0
Spindle CCW indicator	Y13.1
Spindle override cancel indicator	Y13.2
X machine zero return indicator	Y13.3
Y machine zero return indicator	Y13.4
Z machine zero return indicator	Y13.5
TH4 machine zero indicator	Y13.6
DEF indicator	Y13.7
Skip indicator	Y14.0
Single block indicator	Y14.1
Dry run indicator	Y14.2
Miscellaneous(M, S, T) lock indicator	Y14.3
Machine tool lock indicator	Y14.4
Machine tool lamp indicator	Y15.0
Lubrication indicator	Y15.1
Cooling indicator	Y15.2
Chip removal indicator	Y15.3
Feedrate override cancel indicator	Y16.0
Rapid switch indicator	Y16.1
0.001/F0 indicator	Y16.2
0.01/25% indicator	Y16.3
0.1/50% indicator	Y16.4
1/100% indicator	Y16.5
+X indicator	Y17.0
+Y indicator	Y17.1

+Z indicator	Y17.2
+TH4 indicator	Y17.3
USER1 indicator	Y17.4
-X indicator	Y18.0
-Y indicator	Y18.1
-A indicator	Y18.2
-TH4 indicator	Y18.3
USER2 key indicator	Y18.4
Overtravel completion indicator	Y19.0
Feed hold indicator	Y19.1
Cycle start indicator	Y19.2
Tool magazine zero return indicator	Y19.3

3.3 Address (G) from PLC to CNC

Addresses are from G0 to G63. Tpye: INT8U, 64 bytes.

For signals, see Volume Function.

Key signals on the operator panel

Key signal on operator panel	PLC address
Edit mode	G20.0
Auto mode	G20.1
MDI mode	G20.2
Machine zero return mode	G20.3
Single step mode	G20.4
Manual mode	G20.5
MPG mode	G20.6
DNC mode	G20.7
Skip	G21.0
Single block	G21.1
Dry run	G21.2
Miscellaneous (M,S, T) lock	G21.3
Machine tool lock	G21.4
Selection stop	G21.5
Program restart	G21.6
Spindle CW	G22.0
Spindle stop	G22.1
Spindle CCW	G22.2
Spindle negative override	G22.3
Spindle override cancel	G22.4
Spindle positive override	G22.5
Spindle jog	G22.6

Lubrication	G23.0
Cooling	G23.1
Chip removal	G23.2
Cycle start	G23.6
Feed hold	G23.7
Feedrate positive override	G24.0
Feedrate override cancel	G24.1
Feedrate negative override	G24.2
Rapid switch	G24.7
Rapid Fo	G25.0
Rapid 25%	G25.1
Rapid 50%	G25.2
Rapid 100%	G25.3
Incremental step 0.001	G26.0
Incremental step 0.01	G261
Incremental step 0.1	G26.2
Incremental step 1	G26.3
Manual feed axis +X	G27.0
Manual feed axis +Y	G27.1
Manual feed axis +Z	G27.2
Manual feed axis +Th4	G27.3
Manual feed axis -X	G28.0
Manual feed axis -Y	G28.1
Manual feed axis -Z	G28.2
Manual feed axis -Th4	G28.3
Spindle orientation	G29.0
Tool magazine zero return	G29.1
Tool clamp/release	G29.2
Tool magazine CW	G29.3
Tool magazine CCW	G29.4
Tool infeed	G29.5
Tool retraction	G29.6
Tool change manipulator	G29.7
Overtravel release	G30.0

3.4 Address (F) from CNC to PLC

Addresses are from F0 to F63. Tpye: INT8U, 64 bytes.

For signals, see Volume Function.

3.5 Internal relay address (R)

The address area is cleared to zero when the power is turned on.
 Type: INT8U, with 512 bytes.

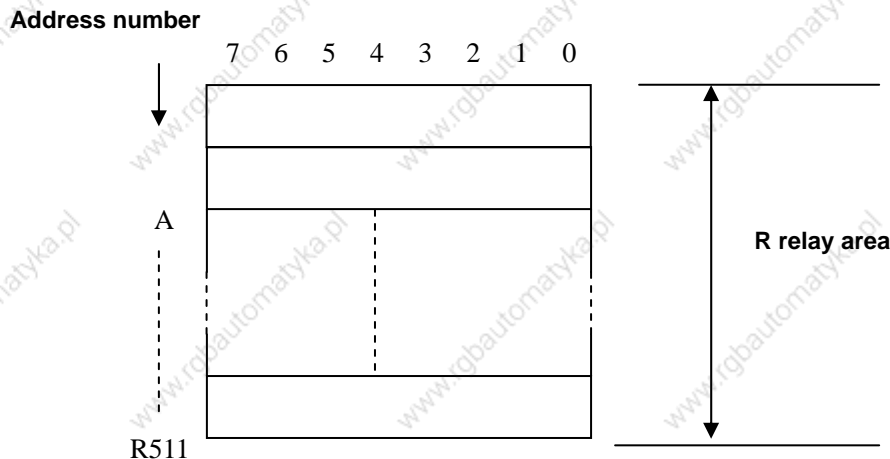

3.6 Address of keep relay (K)

The area is used as keep relays and PMC parameters. In each modal, the following number of bytes can be used. Since this area is nonvolatile, the content of the memory do not disappear even when the power is turned off.
 Type: INT8U, with 64 bytes.

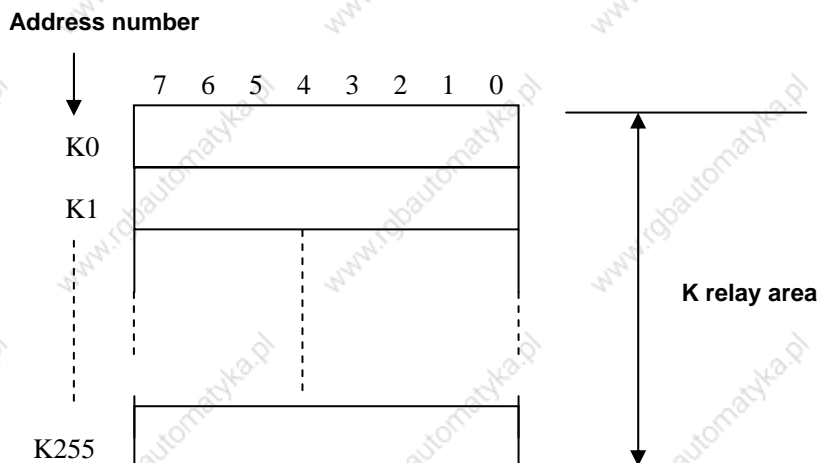

3.7 Addresses(A) for message selection displayed on CRT

The address area is cleared to zero when the power is turned on.
 Type: INT8U, with 32 bytes.

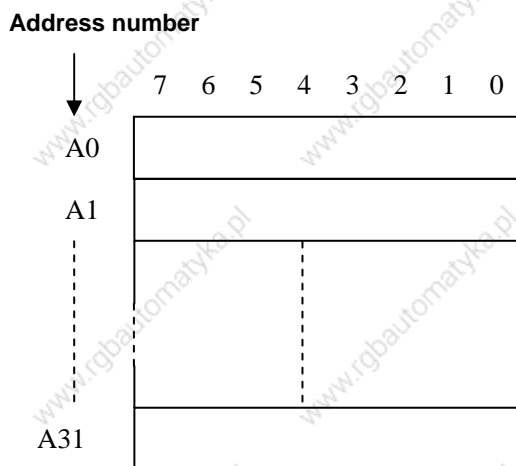

3.8 Address of meter (C)

The area is used as storing current counting value in meter. The address area is cleared to zero when the power is turned on.

Type: 128 addresses.

3.9 Meter preset address(DC)

The address area is used to store the meter preset value. Since this area is nonvolatile, the content of the memory do not disappear even when the power is turned off.

Type: 128 addresses.

3.10 Timer addresses (T)

The area is used as storing current counting value in timer. The initial data is the preset value when the system is turned off. When preset value is 0, the current data is preset value.

Type: 128 addresses.

3.11 Addresses of timer preset value (DT)

The address area is used as storing preset value. Since this area is nonvolatile, the content of the memory do not disappear even when the power is turned off.

Type: 128 addresses.

3.12 Address of data table (D)

The content of the memory do not disappear even when the power is turned off.

Type: 256 addresses. D240~247 are for tool magazine.

3.13 Label address (L)

Label addresses are used to specify jump destination labels and LBL labels in JMPB instructions.

Range: 0~99

3.14 Subprogram numbers (P)

Subprogram numbers are used to specify jump destination subprogram labels and SP instruction subprogram labels in CALL instruction.

Range: 0~99

4 PLC Basic Instruction

Designing a sequence program begins with writing a ladder diagram. The ladder diagram is written using relay contact symbols and functional instruction code. Logic written in the ladder diagram is entered as a sequence program in the Programmer. There are two sequence program entry methods. One is the entry method with the mnemonic language(PLC instructions such as RD, AND, OR). The other is the relay symbols of the ladder diagram. When the relay symbol method is used, the ladder diagram format can be used and programming can be performed without understanding the PLC instruction format.

Actually, however, the sequence program entered by the relay symbol method is also internally converted into the instruction corresponding to the PLC instruction.

The basic instructions are often used when the sequence program is designed, and they execute one-bit operation.

GSK218M basic instructions are as follows:

Instruction	Function
RD	Shifts left the content by one bit in register and sets the state of a specified signal in ST0.
RD.NOT	Shifts left the content by one bit in register and sets the logic state of a specified signal in ST0.
WRT	Outputs the results of logic operation to a specified address.
WRT.NOT	Inverts the results of logical operations and outputs it to a specified address.
AND	Induces a logical product.
AND.NOT	Inverts the state of a specified signal and induces a logical product.
OR	Induces a logical sum.
OR.NOT	Inverts the state of a specified signal and induces a logical sum.
OR._STK	Sets the logical sum of ST0 and ST1, and shifts the stack register right by one bit.
AND.STK	Sets the logical product of ST0 and ST1, and shifts the stack register right by one bit.

4.1 RD, RD.NOT, WRT, WRT.NOT

Instructions and functions

Instruction	Function
RD	Shifts left the content by one bit in register and sets the state of a specified signal in ST0.
RD.NOT	Shifts left the content by one bit in register and sets the logic state of a specified signal in ST0.
WRT	Outputs the results of logic operation to a specified address.
WRT.NOT	Inverts the results of logical operations and output it to a specified address.

Instruction specifications:

- WRT, WRT. NOT are the output relay, internal relay instructions. They cannot be used to input relay.
- The parallel WRT instruction can be continuously used many times.

Programming

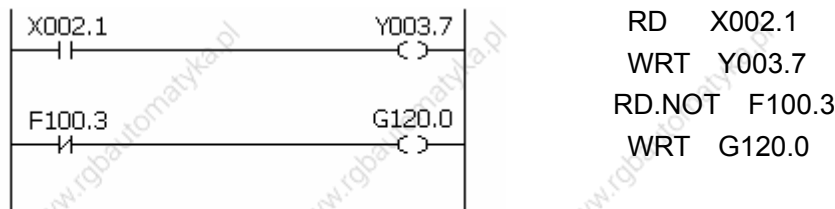

4.2 AND, AND.NOT instructions

Instructions and functions

Instruction	Function
AND	Induces a logical product.
AND.NOT	Inverts the state of a specified signal and induces a logical product.

Instruction specifications:

- AND, AND NOT can connect with one contact in serial. The serial contact numbers are not limited and they can be used many times.

Programming

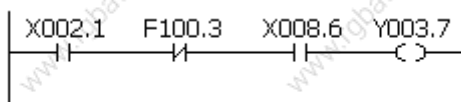

```
RD X002.1
AND.NOT F100.3
AND X008.6
WRT Y003.7
```

4.3 OR, OR.NOT instructions

Instructions and functions

Instruction	Function
OR	Induces a logical sum.
OR.NOT	Inverts the state of a specified signal and induces a logical sum.

Instruction specification:

- OR, OR_NOT can connect with one contact in parallel.
- OR, OR.NOT begins from their step, which can connect with the froementioned step in parallel.

Programming:



```
RD X002.1
OR_NOT F100.3
WRT Y003.7
```

4.4 OR. STK instruction

Instruction and function:

Instruction	Function
OR. STK	Sets the logical sum of ST0 and ST1, and shifts the stack register right by one bit.

Instruction specification:

- OR.STK a sole instruction without other address.

Programming

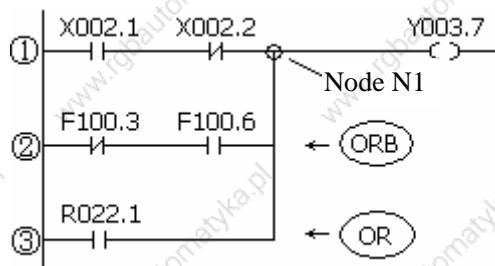

```

RD X002.1
AND.NOT X002.2
RD.NOT F100.3
AND F100.6
OR.STK
RD R022.1
WRT Y003.7
    
```

As the above figure, there are three branch circuit ①, ②, ③ from left bus to the node N1, among which ①, ② is circuit block in series; when there is the serial circuit block in the parallel from the bus to node or between nodes, the following branch end uses RD instruction except for the first branch. The branch ③ is not serial circuit block to use OR instruction.

OR.STK and AND.STK are instructions without operation components, indicating the OR, AND relationship between circuit blocks.

4.5 AND.STK instruction

Instruction and function

Instruction	Function
AND.STK	Sets the logical product of ST0 and ST1, and shifts the stack register right by one bit.

Instruction specification

- When the branch loop (parallel loop block) is connected to the previous loop in series, use AND.STK instruction. The starting point of branch uses RD, RD.NOT instruction, after the parallel loop block ends, AND,STK instruction is connected to previous loop in series.
- AND.STK a sole instruction without other address.

Programming

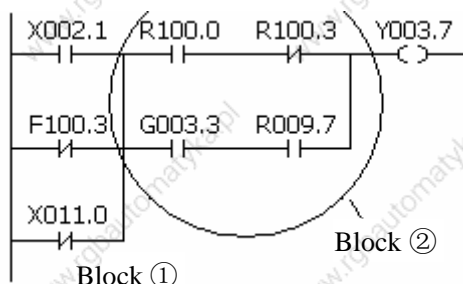

```

RD X002.1
OR.NOT F100.3
OR.NOT X011.0
RD R100.0
AND.NOT R100.3
RD G003.3
AND R009.7
RD ← (1)
AND.STK ← (2)
WRT Y003.7
    
```

As the above figure and instruction list, (1)RD reports the circuit block in series is connected parallelly; (2)AND.STK reports the block ① and ② are connected in series.

5 PLC Functional Instructions

Basic instructions such as controlling operations of machine tool are difficult to program, therefore, functional instructions are available to facilitate programming.

218M functional instruction as follows:

No.	Instruction	Processing
1	END1	End of a first-level ladder program
2	END2	End of a second-level ladder program
3	CALL	Calling subprogram
4	SP	Subprogram
5	SPE	End of subprogram
6	SET	Set
7	RST	Reset
8	JMPB	Lable jump
9	LBL	Label
10	TMR	Timer
11	CTR	Binary meter
12	DEC	Binary decoding
13	COD	Binary code conversion
14	COM	Common line control
15	COME	End of common line control
16	ROT	Binary rotation control
17	SFT	Register shift
18	DIFU	Rising edge check
19	DIFD	Failing edge check
20	COMP	Binary comparison
21	COIN	Coincidence check
22	MOVN	Transfer of an arbitrary number of bytes
23	XMOV	Indexed data transfer
24	DSCH	Binary data search
25	ADD	Binary addition
26	SUB	Binary subtraction
27	ANDF	Logical production

28	ORF	Logical Add
29	NOT	Logical Negation
30	EOR	Exclusive OR

5.1 END1 (1st level sequence program end)

Function:

Must be specified once in a sequence program, either at the end of the 1st level sequence, or at the beginning of the 2nd level sequence when there is no 1st level sequence. It can write 100 steps.

Format:

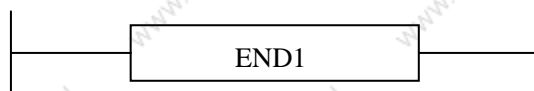

5.2 END2 (2nd level sequence program end)

Function

Specify at the end of 2nd level sequence.

Format:

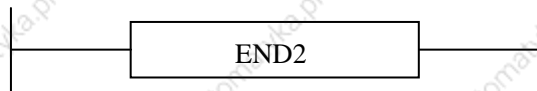

5.3 CALL (call subprogram)

Function

Call a specified subprogram.

CALL has the following additional functions:

- * More than one call instructions can call the same subprogram.
- * Calling instruction can be nested.
- * Cannot call subprogram in 1st level sequence program.
- * Subprogram must be written after END2.

Format:

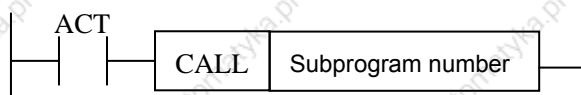

Control condition:

ACT=0, execute the next instruction behind CALL.

ACT=1, call subprogram which number is specified.

Parameter:

Subprogram: specifies the subprogram number of a subprogram to be coded following this instruction. Range: 0~99.

5.4 SP (Subprogram)

Function:

The SP functional instruction is used to create a subprogram. A subprogram number is specified as a subprogram name. SP is use with the SPE functional instruction to specify the subprogram range.

Note:

1. A subprogram must be written after END2.
2. Another subprogram cannot be nested into a subprogram.

Format:

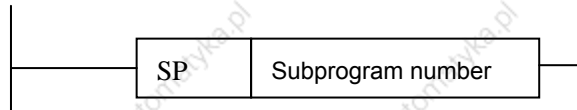

Parameter:

Subprogram number: specifies the subprogram label of a subprogram to be coded following this instruction. Range: 0~99.

5.5 SPE (subprogram end)

Function:

- * it is used to specify the range of subprogram when SPE is used with the S P.
- * the control will return to the main program which called the subprogram when the instruction is executed.
- * the subprogram is written after END2.

Format:



Example:

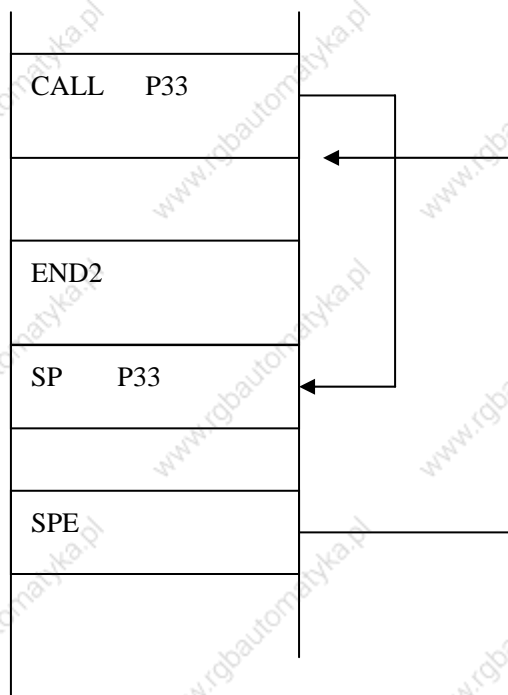

5.6 SET (set)

Function:

Set to 1 for the specified address.

Format:

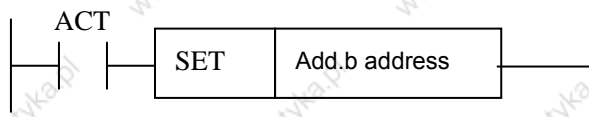

Control condition:

ACT=0, add.b keep invariably.

ACT=1, add.b set to 1.

Parameter:

Add.b: set element address bit can be the output coil, Add= Y, G, R, K, A.

5.7 RST (reset)

Function:

Set to 0 for the specified address.

Format:

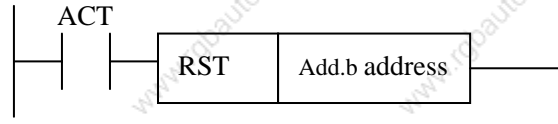

Control condition:

ACT=0, add.b keep invariably.

ACT=1, add.b set to1.

Parameter:

Add.b: reset element address bit can be the output coil, Add= Y, G, R, K, A.

5.8 JMPB (label jump)

Function:

The JUMP functional instruction transfer control to a Ladder immediately after the lable set in a Ladder program.

JMPB has the following additional functions:

- * More than one jump instruction can be coded for the same label.
- * Jumped END1 and END2 are forbidden.
- * Jump instructions can transfer control freely before and after the instruction withinthe program unit in which the instruction is coded.
- * Jump can be executed.

Format:

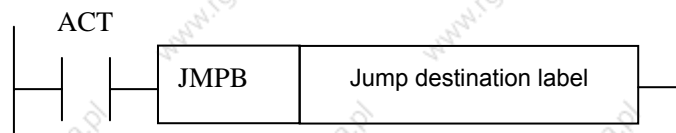

Control conditions:

ACT=0: The next instruction after the JMPB instruction is executed.

ACT=1: Control is transferred to the Ladder immediately after the specified label.

Parameter:

Lx: specifies the label of the jump destination. A value from 0 to 99 can be specified.

5.9 LBL (Label)

Function:

The LBL functional instruction specifies a label in a ladder program. It specifies the jump

destination for JMPB functional instruction.

Note: one Lx label is only specified one time with LBL. Otherwise, the system alarms.

Format:

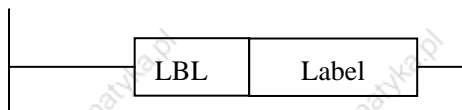

Parameter:

Lx: specifies the label of the jump destination. Label number range: 0~99

Example:

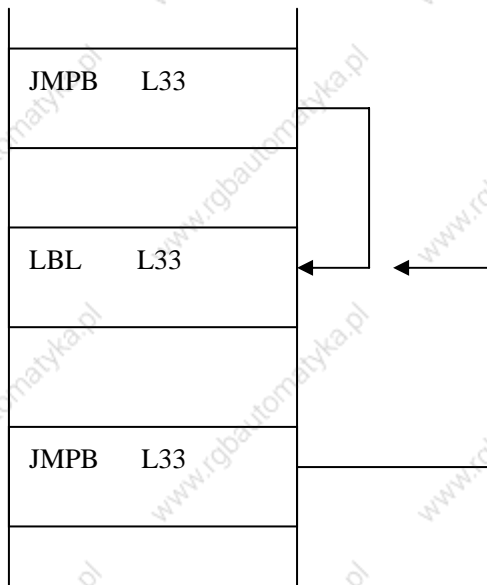

5.10 TMR (timer)

Function:

This is an on-delay timer.

Format:

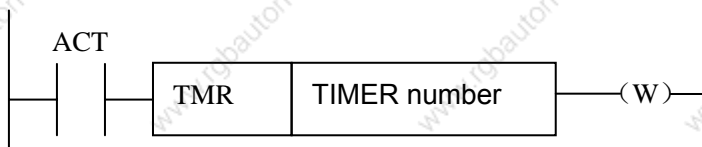

Control condition:

ACT=0: turns off the timer relay.

ACT=1: initiates the timer, i.e. timing from 0.

Detailed functions:

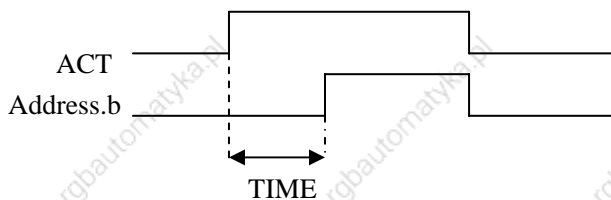

Parameter:

TIMER : timer serial number is named with xxx which are numbers (0~127).

Output:

W : output coil. W=1 when the output reaches the preset value. W=0 when the output does not reach the preset value.

Note:

The setting time is every 4ms for the timer.

The timer can be set via **【TMR】** in **【PLCPAR】** .

5.11 CTR (binary counter)

Function:

The data in the counter are binary and their functions are as follows:

- 1) Preset counter
Preset the count. It outputs a signal when the preset count is reached.
- 2) Ring counter
Upon reaching the preset count, returns to the initial value by issuing another counter signal.
- 3) Up/down counter
The count can be either up or down.
- 4) Selection of initial value
Its initial value is 0 or 1.

Format:

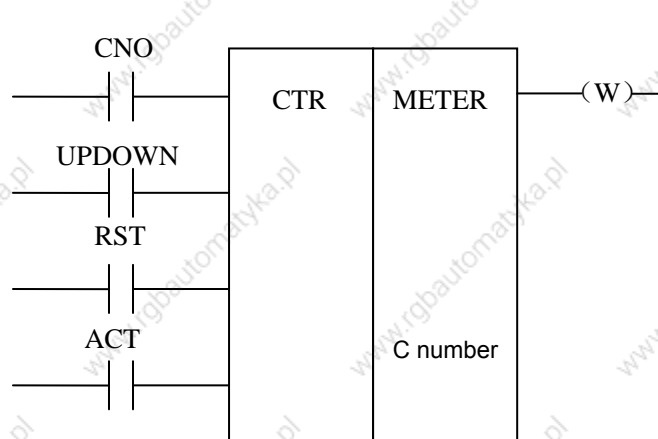

Control condition:

Specifies the initial value(CN0):

CN0=0: begins the value of the counter with 0.

CN0=1 begins the value of the counter with 1.

Specify up or down counter (UPDOWN):

UPDOWN=1: Up counter

UPDOWN=0: Down counter

Reset (RST):

RST=0: release reset.

RST=1: enable reset. When W=0, the iterated value is reset to the initial value.

RST is set to 1 only when reset is required.

Count signal(ACT):

ACT=1: count is made by catching the rise of ACT.

ACT=0: counter does not operate. W does not change.

Parameter:

METER: specifies the counter serial number with xxx which are numbers (0~127).

Output:

W: coil output. W=1 when the counter reaches the preset value.

Note: When the counter is rise edge to count, and the conter number is duplicated,or falls outside the valid range, the operation will be unpredictable.

The timer can be set via **【TMR】** in **【PLCPAR】** .

5.12 DEC (binary decode)

Function:

DEC can decode binary code data. Outputs 1 when the eight-digit BCD signal is equal to a specified number, and 0 when not.

It is mainly used to decode M or T function.

Format:

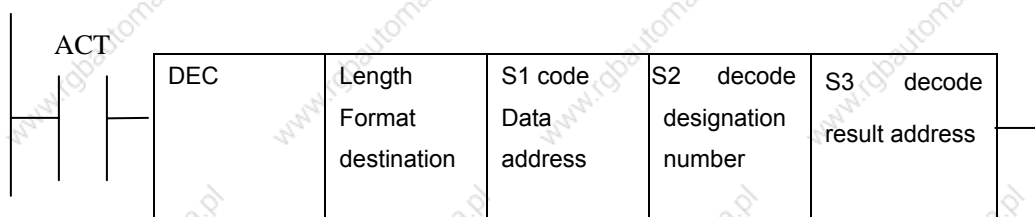

Control condition:

ACT=0 : resets all the output data bit.

ACT=1 : decode data. Results of processing is set in the output data address.

Parameter:

length : Set the size of code data to the 1st digit of the parameter.

0001: code data is in binary format of 1 byte length.

0002: code data is in binary format of 2 byte length.

S1 : code data address. Specifies an address at which code data is stored.

S2 : number specification decode designation. Specifies the first of the 8 continuous numbers to be decoded.

S3 : decode result address. Specifies an address where the decoded result shall be output. A one-byte area is necessary in the memory for the output.

Example:

DEC 1 F10 8 R4

When ACT=1 and F10=8, R4=0000,0001;

When ACT=1 and F10=9, R4=0000,0010;

.....

When ACT=1 and F10=15, R4=1000,0000;

5.13 COD (binary code conversion)

Function:

COD instruction automatically creates a table with corresponding size used for user inputting conversion table data when it inputs the data capacity. Each table has 10 lattices and if it is not divided by 10, count the lattices by its quotient adding 1, but its capacity data does not change.

Format:

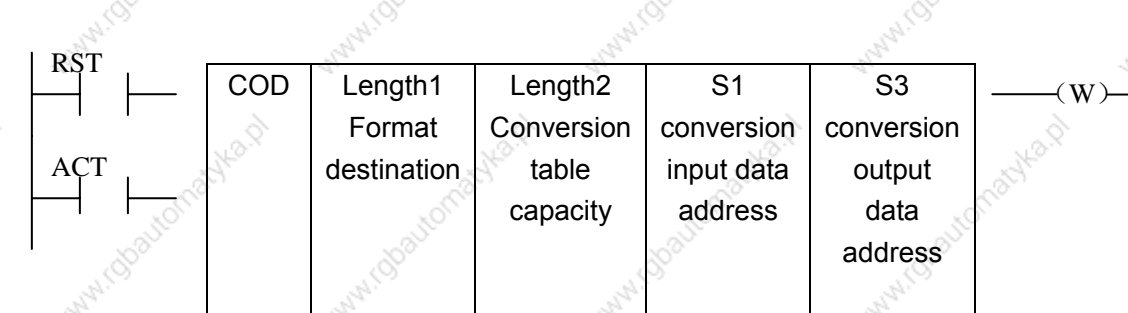

S1	0	1	2	N-1
S2	XXX	YYY	AAA	UUU

Control conditions:

Reset (RST):

RST=0: do not reset.

RST=1: reset error output W.

Activate instruction (ACT):

ACT=0 : do not execute COD.

ACT=1 : execute COD. Take value of "Conversion input data address(S1)" as the table number of conversion table, take out of 1 conversion data which corresponds to the table number from the conversion table, output the output address used for the conversion data (S2).

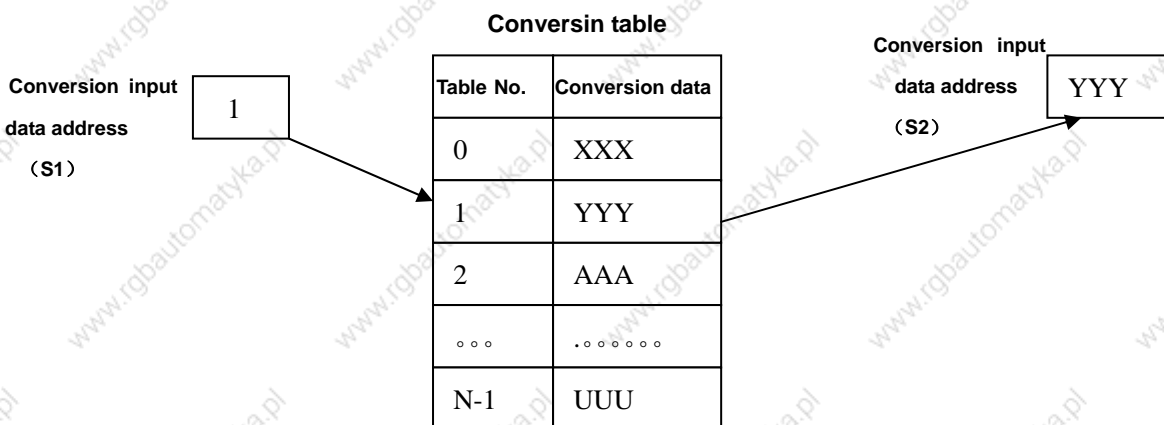

Parameter:

Length1 : designates binary numeral size in the conversion table.

- 1: Numerical data is binary 1-byte data.
- 2: Numerical data is binary 2-byte data.

length2 : Number of conversion table data. 100 data can be made. 100 bytes when designating 1 byte format, and 100 words when 2 byte format. All number is at most 512 bytes in COD conversion table.

- 1: 2 bytes
- 2: 4 bytes
- 3: 8 bytes
- 4: 16 bytes
- 5: 32 bytes
- 6: 64 bytes
- 7: 128 bytes
- 8: 256 bytes

S1 : Data in the conversion data table can be taken out by specifying the table number. The address specifying the table number is called conversion input data address, and 1-byte memor is required from the specified address.

S2 : Conversion data output address. Memory of the byte length specified in the format designation is necessary from the specified address.

Output:

If there are any abnormality when executing the CODB instruction, W=1, and error will be output.

Note: Size of the conversion data table is maximum 256. This conversion data table is programmed between the parameter conversion data output address of this instruction and the error output(W).

5.14 COM (common line control)

Function:

This function can be used for specifying the number of coil only on the PMC-SB/SC. If the common line end instruction is not specified, the system will alarm.

Format:

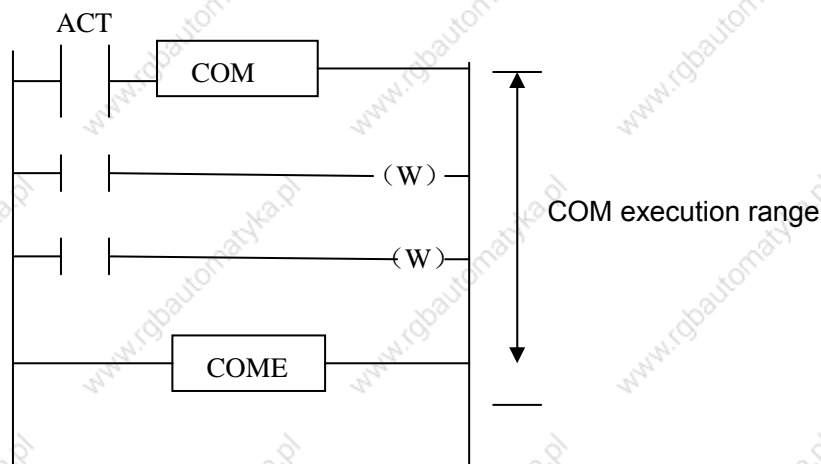

Control condition:

ACT=0: The specified number of coils or the coils within the region specified are unconditionally turned off (W=0).

ACT=1: No processing is performed.

Note:

1. In the range specified with a COM instruction, no additional COM instruction can be specified.
2. the coil for WRT.NOT in the range specified with a COM instruction is unconditionally set to 1 when COM ACT=0.
3. do not use the function block between COM and COME, otherwise, the system will alarm.

5.15 COME (common line control end)

Function:

The instruction reports the division in the region specification of the common line control instruction (COM). This instruction cannot be used alone. It must be used together with the COM instruction.

Format:

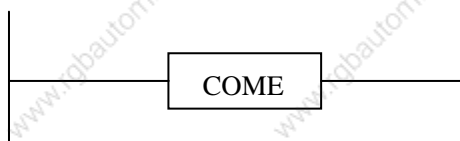

5.16 ROT (Binary rotation control)

Function:

Controls rotors, such as the toolpost, rotary table, etc., and is used for the following functions.

1. Selection of the rotation direction via the shorter path.
2. Calculation of the number of steps between the current position and the goal position; calculation of the position on position before the goal to the number of steps up to one position before the goal.
3. Calculation of the position one position before the goal or of the number of steps up to one position before the goal.

Format:

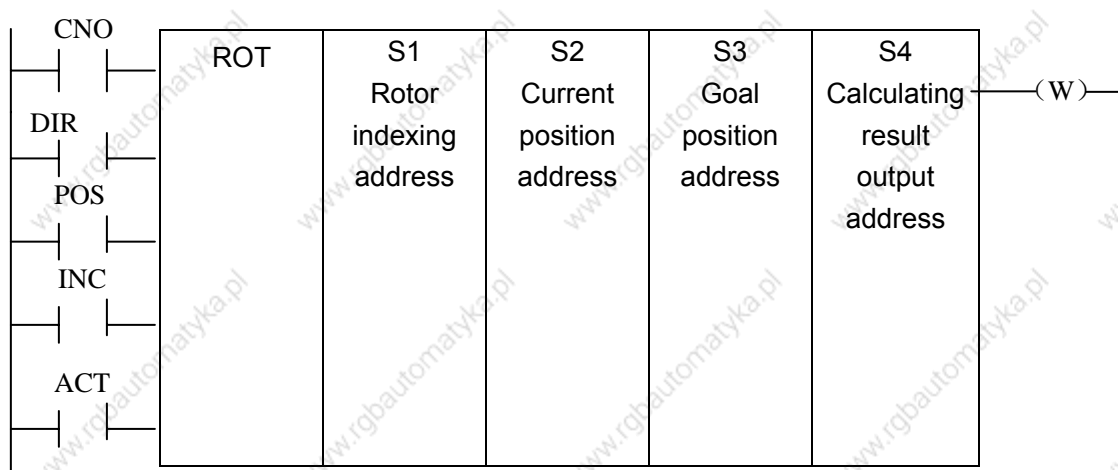

Control conditions:

Specify the starting number of the rotor(CNO):

CNO=0: begins the number of the position of the rotor with 0.

CNO=1: begins the number of the position of the rotor with 1.

Select the rotation direction via the shorter path or not: (DIR):

DIR=0: no direction is selected. The direction of rotation is only forward.

DIR=1: selected. The direction of rotation is forward/backward.

Specify the operating conditions (POS):

POS=0: calculate the goal position.

POS=1: calculates the position one position before the goal position.

Specify the position or the number of steps(INC):

INC=0: calculates the number of the position. If the position one position before the goal position is to be calculated, specify INC=0 and POS=1.

INC=1: calculates the number of steps. If the difference between the current

position and the goal position is to be calculated, specify INC=1 and POS=0.

Execution instruction (ACT):

ACT= 0: the ROT instruction is not executed. W does not change.

ACT = 1 : executed. Normally, set ACT=0. If the operation results are required, set ACT=1.

Parameter:

- S1 : specify the rotor indexing number.
- S2 : specify the address storing the current position.
- S3 : specify the address storing the goal position(or instruction value), for example the address storing the CNC output T code.
- S4 : calculate the number of steps for the rotor to rotate, the number of steps up to the position one position before, or the position before the goal. When the calculating result is to be used, always check that ACT=1.

Output:

W: The direction of rotation for control of rotation via the shorter path is output to W. When W=0, the direction is forward (FOR) when 1, reverse (REV). The definition of FOR and REV is shown in the following figure. If the number given to the rotor is ascending, the rotation is FOR; if descending, REV. The address of W can be determined arbitrarily. When, however, the result of W is to be used, always check that ACT=1.

Example:

Rotor rotation direction:

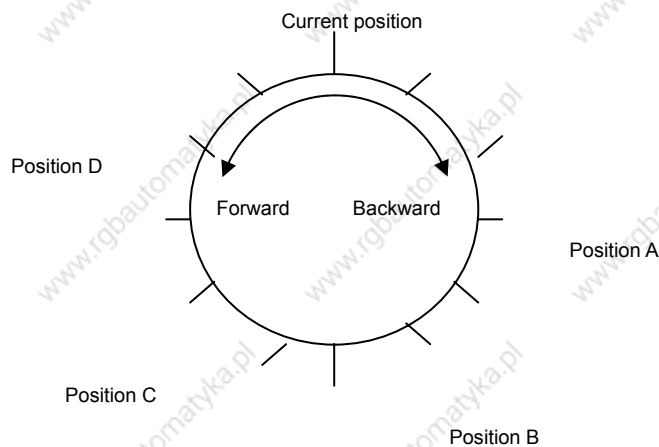

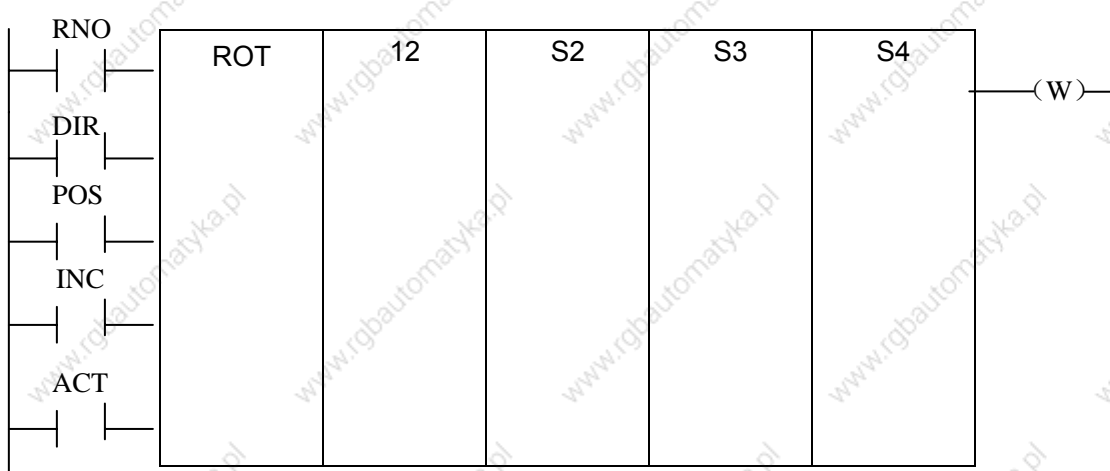

Perform the short path rotation, and calculate the position number of previous one position of goal position.

Current position number S2=1, position number of rotation graduation S1=12, RNO=1, DIR=1 POS=1, INC=0:

When S3=10 goal position is A, and ACT=1, S4=11, W=1.

When S3=8 goal position is B, and ACT=1, S4=9, W=1.

When S3=5 goal position is C, and ACT=1, S4=4, W=0.

When S3=3 goal position is D, and ACT=1, S4=2, W=0.

5.17 SFT (shift register)

Function:

The instruction shifts 1-byte (8-bit) data by a bit to the left or right. Note that W=1 when data "1" is shifted from the left extremity (bit 8) in left shift or from the right extremity (bit 0) in right shift.

Format:

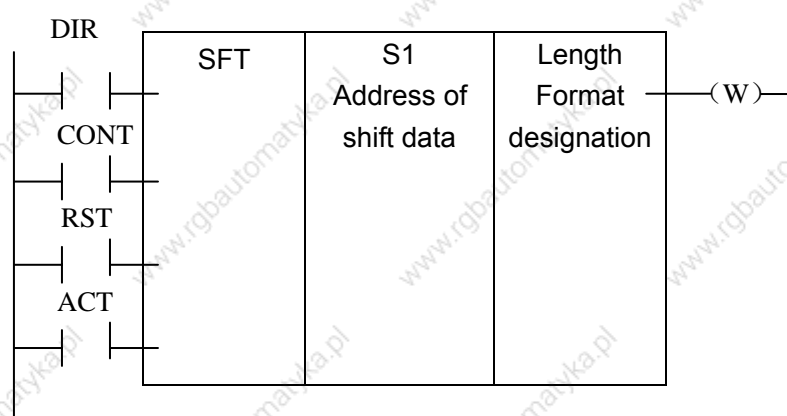

Control conditions:

Shift direction specification (DIR)

DIR=0: Left shift

DIR=1: Right shift

Condition specification (CONT)

CONT=0: do not cycle shift

CONT=1: cycle shift

Reset (RST)

The shifted out data(W=1) is reset (W=0).

RST=0: W is not reset.

RST=1: W is reset (W=0).

Actuation signal (ACT)

ACT=0: do not execute SFT instruction.

ACT=1: shifting processing is done when ACT=1. For shifting one bit only, execute an instructin when ACT=1, and then, set ACT to 0.

Parameters:

S1 : sets shift data addresses. These designated addresses require a continuous 1-byte memory for shift data.

Length : a 4-bit number, and its definition is as follows:

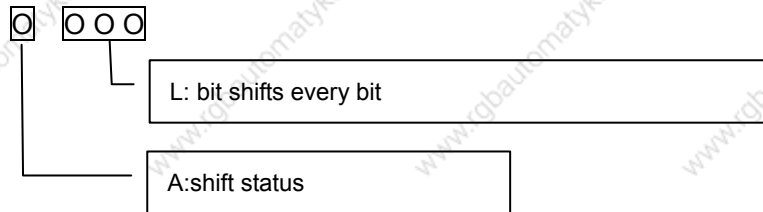

L : range: 0~8.

A : bit parameter. A=0: When ACT=1 is shifting, the shift period is one bit.

A=1: ACT is taken as pulse signal, it is 1 from 0, shift one bit.

Output:

W : W=0: "1" was not shifted out because of the shift operation.

W=1: "1" was shifted out because of the shift operation.

5.18 DIFU (rising edge check)

Function:

The DIFU instruction sets the output signal to 1 for one scanning cycle on a rising edge of the input signal.

Format:

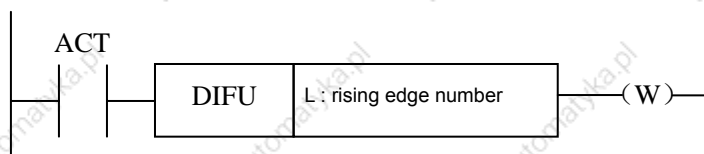

Control condition:

Input signal: On a rising edge (0→1) of the input signal, the output signal is set to 1.

Output signal: The output signal level remains at 1 for one scanning cycle of the ladder level where this functional instruction is operating.

Parameter: Rising edge number

Parameter: L :rising edge number, range 0~255. Another DIFU instruction or DIFD instructin in the ladder uses the same number, the system will alarm.

Operation:

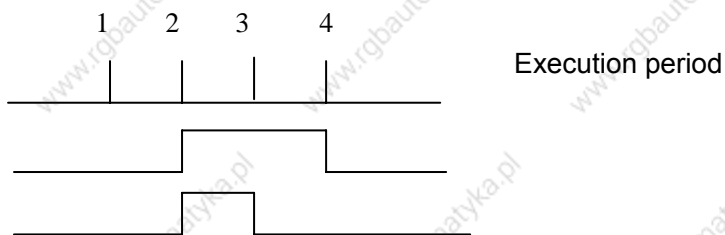

5.19 DIFD (falling edge check)

Function:

The DIFD instruction set the output signal to 1 for one scanning period on a falling edge of the input signal.

Format:

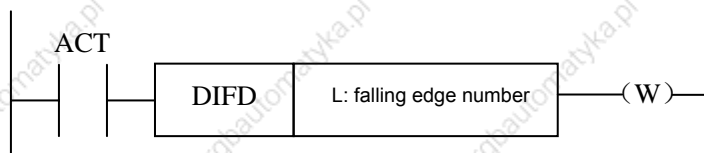

Control conditions:

Input signal: on a falling edge (1→0) of the input signal, the output signal is set to 1.

Output signal: the output signal level remains at 1 for one scanning period of the ladder level where this functional instruction is operating.

Parameter:

L : rising edge number, range 0~255. Another DIFU instruction or DIFD instruction in the ladder uses the same number, the system will alarm.

Operation:

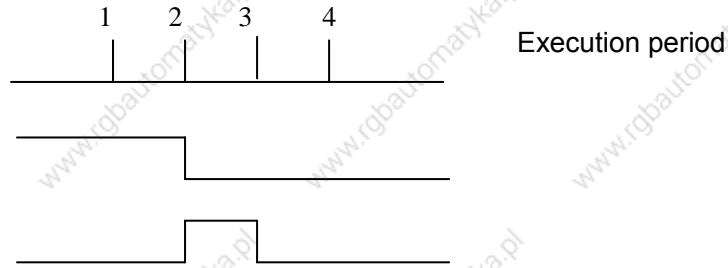

5.20 COMP (binary comparison)

Function:

Compares binary values. Specifies enough byte to store input data and comparison data in the memory.

Format:

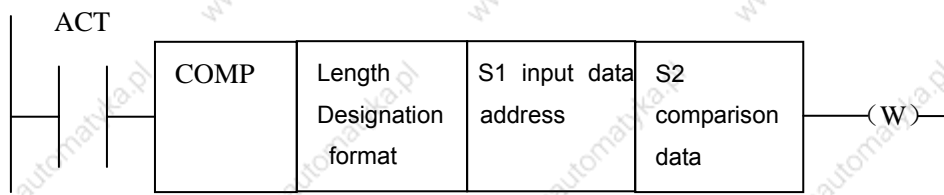

Control conditions:

ACT=0: The COMP instruction is not executed. W does not alter.

ACT=1: The COMP instruction is executed.

Parameter:

Length: specification format(constant or address) and data length(1 or 2 bytes) for the input data.

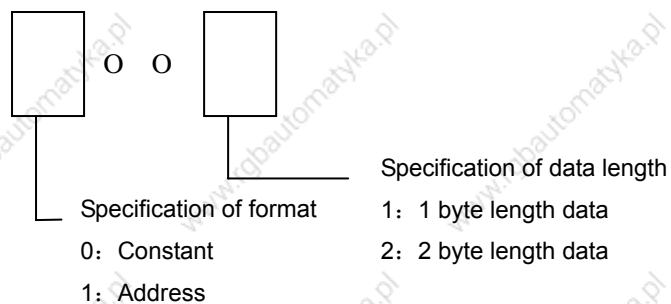

S1, S2: content of comparison source 1 and comparison source 2. It can be

constant and also be address number.

Address number: R, X, Y, F, G, K, A, D, T, C.

Output:

W=0: input data > comparison data

W=1: input data ≤ comparison data

5.21 COIN (concidence check)

Function:

Checks whether the input value and comparison value coincide.

Format:

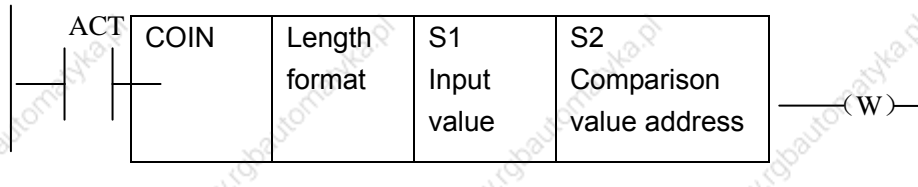

Control conditions:

ACT=0, the COIN instruction is not executed. W does not change.

ACT=1, the COIN instruction is executed.

Parameter:

Length: specification format(constant or address) and data length(1 or 2 bytes) for the input data.

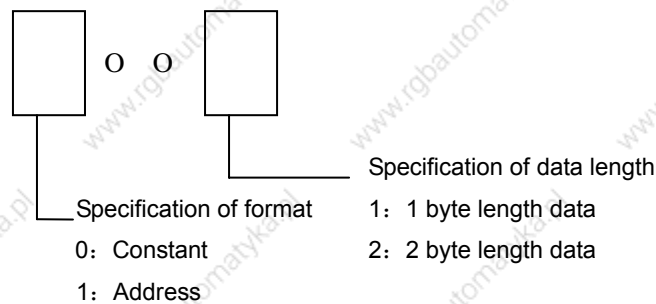

S1 : The input data can be specified as either a constant or an address storing it.

S2 : address storing of comparison data

Output:

W : W=0: input value≠comparison value
 W=1: input value=comparison value

5.22 MOVN (transfer of data)

Function:

The MOVN instruction transfers data from source address and a specified binary data to a specified destination address.

Format:

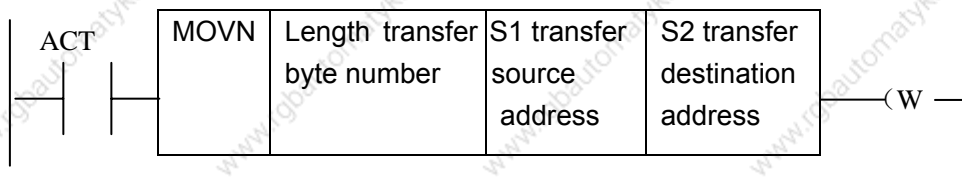

Control condition:

ACT=0: No data is transferred.
 ACT=1: The byte of specified number is transferred.

Parameter:

Length : transferred byte number.
 S1 : stating byte of address or constant of source data.

Selecting transfer format according to S1:

1. S1 is constant: if S2 is single byte address, S1 in byte unit is copied to address corresponding to Length byte which takes S2 as the initial; if S2 is in word unit, it is copied in word address;
2. S1 is address: S1 and S2 transmit the data in byte in spit if S1 and S2 address classifications are matched.

S2 : starting byte of destination address.

Example:

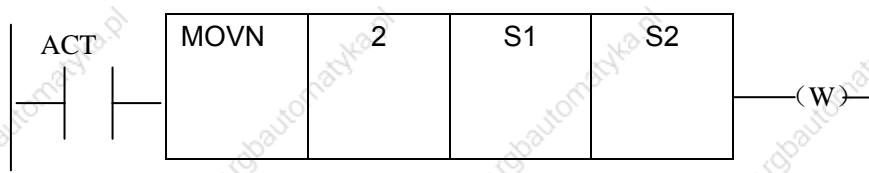

- S1 : Storage address of number of data table elements. The address is used to store the data number of data table, its byte should correspond to the length specified in Length format specification, and the effective range of number of data table element is as follows with the byte length which set in Length1 format.
- 1 byte length: 1 to 255.
 - 2 byte length: 1 to 32767 (Actually, set a value below the size of the D area.
- S2 : Sets head address in the data table. The memory of (byte length)X (number of data table elements).
- S3 : Input/output data storage address. In case of the reading, set the address of the memory which stores a reading result a writing result. The memory with the byte length which set in Length format specification is necessary.
- S4 : Index storage address. Set the address of the memory in which an index value is stored. The memory with the byte length set in Length format specification is necessary. When setting an index value above the value to set in S1 storage address of number of data table elements, it causes an error output W=1. Actually, the number of data table elements does not exceed 255.

Output:

The index value set in Index storage address exceeds the value set in S1, W=1, the reading or writing of the data table isn't executed.

W=0, No error.

W=1, Error found.

5.24 DSCH (binary data search)

Function:

The DSCH instruction is used to search the binary data in data table. The number of data (table capacity) in the data table can be specified by specifying the address. Thus allowing change in table capacity even after writing the sequence program in the ROM.

Format:

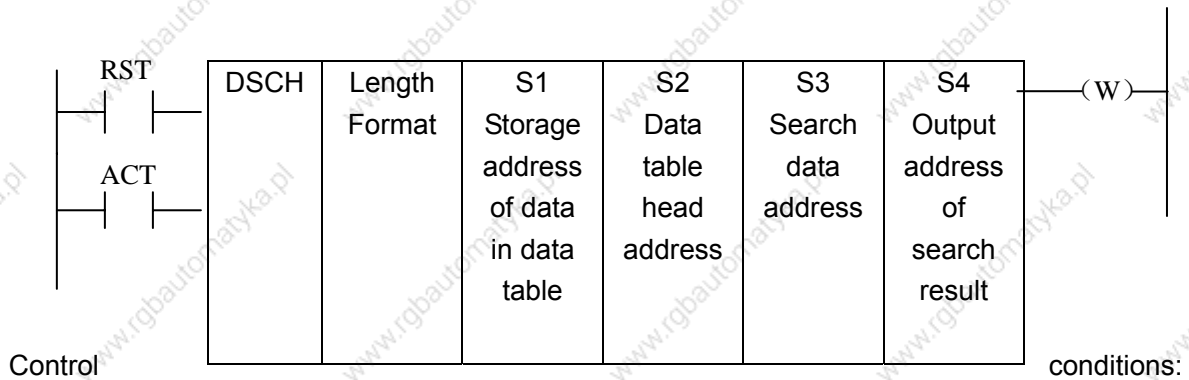

Reset (RST)

RST=0: Release reset.

RST=1: Reset. W=0.

Activation instruction (ACT):

ACT=0 : Do not execute DSCH instruction, W does not change.

ACT=1 : Execute DSCH instruction. If the search data is found, table number where the data is stored will be output. If the search data is not found, W becomes 1.

Parameter:

Length : Specifies data length

1: 1-byte long data.

2: 2-byte long data.

S1 : Storage address of number of data in data table. This address requires memory of number of byte according to the format designation. Number of data in the table is n+1(head number in the table is 0 and the last number is n).

S2 : Data table head address.

S3 : Search data input address.

S4 : Search result output address. After searching, if search data is found, the table number where the data is stored will be output. the searched table number is output in this search result output address. This address requires memory of number of byte according to the format designation.

Output:

W=0, Search data found.

W=1, Search data not found.

5.25 ADD (addition)

Function:

This instruction performs binary addition between 1-, 2-byte data. In the operation result register, operation data is set besides the numerical data representing the operation results. The required number of bytes is necessary to store each augend, the addend, and the operation output data.

Format:

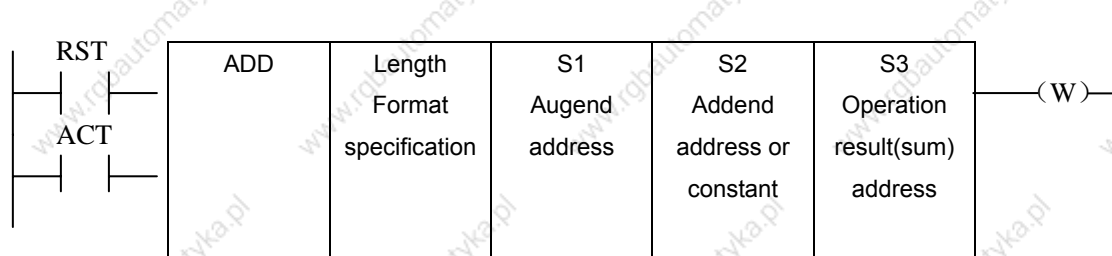

Control conditions:

Reset (RST):

RST=0: Release reset.

RST=1: Reset. W=1.

Activation instruction (ACT):

ACT=0 : Do not execute ADD. W does not change.

ACT=1 : Execute ADD.

Parameter:

Length : Specifies data length(1 or 2 bytes) and the format for the addend(constant or address).

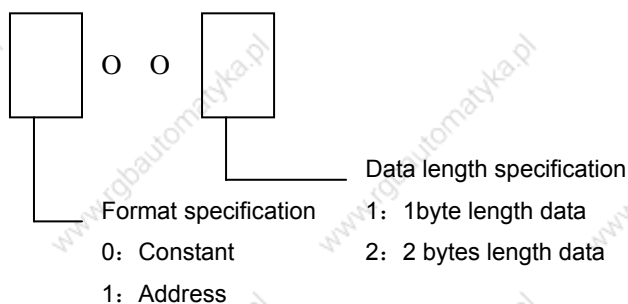

S1 : Augend address.

S2 : Addend data specification determines the format of the addend.

S3 : Specify the address to contain the result of output operation.

Output:

W=0: Operation correct.

W=1: Operation incorrect.

When W=1, the result of addition exceeds the specified data length.

5.26 SUB (binary subtraction)

Function:

This instruction executes the subtraction operation in the binary format of 1 or 2 bytes. In the operation result register, operation data is set besides the numerical data representing the operation. A required number of bytes is necessary to store the subtrahend, and the result.

Format:

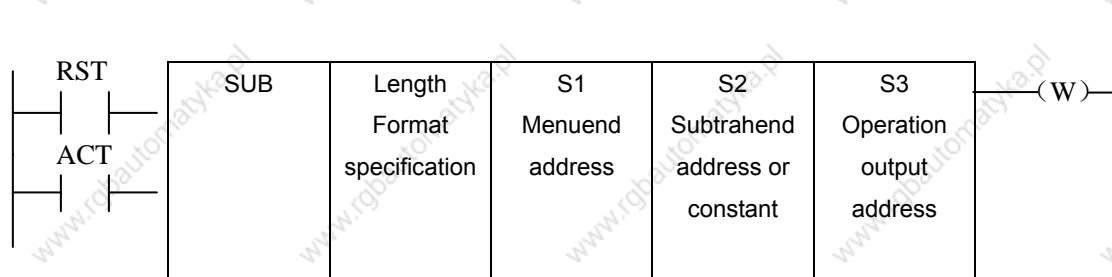

Control conditions:

Reset (RST):

RST=0: Release reset.

RST=1: Reset. W=0.

Activation instruction (ACT):

ACT=0 : Do not execute SUB. W does not change.

ACT=1 : Execute SUB.

Parameter:

Length : Specifies data length(1 or 2 bytes) and the format for the subtrahend(constant or address).

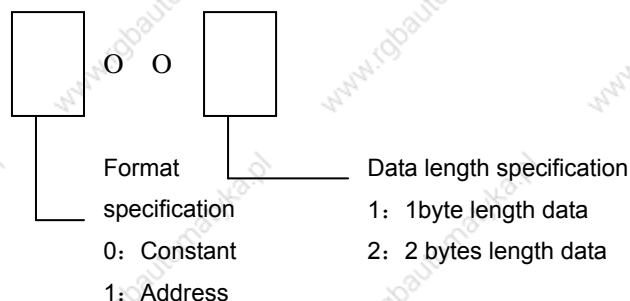

S1 : Address containing the minend.

S2 : Specification determines the Length.

S3 : Specifies the address to contain the result of operation.

Output:

W=0: Operation correct.

W=1: Operation incorrect.

When W=1, the result of subtraction exceeds the specified data length.

5.27 ANDF (logical and)

Function:

The ANDF instruction ANDFs the contents of address A with a constant(or the contents of address B), and stores the result at address C.

Format:

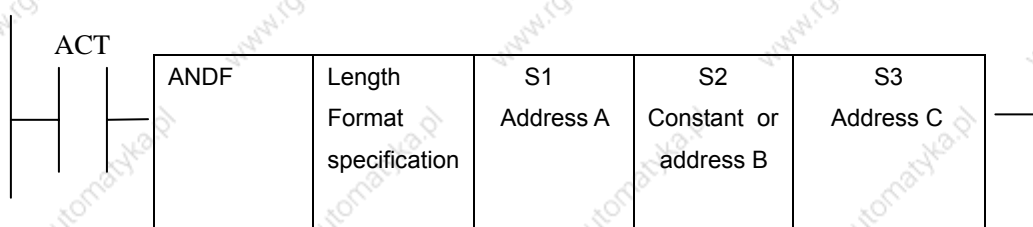

Control conditions:

ACT=0 : The ANDF instructin is not executed.

ACT=1 : The ANDF instruction is executed.

Parameter:

Length : Specify a data length (1 or 2 bytes), and an input data format(constant or addressspecification).

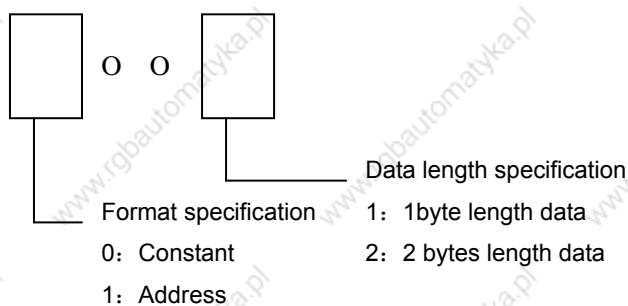

S1 : Input data to be ANDFed. The data that is held starting at this address and has the data length specified in Length format specification is treated as input data.

S2 : Input data to be ANDFed with. When address specification is selected in format specification, the data that is held starting at this address and has the data length specified in Length format specification is treated as input data.

S3 : Address used to store the result of an ANDF operation. The result of and ANDFoperation is stored starting at this address, and has the data length specified in Length format specification.

Example:

When address A and address B hold the following data:

Address A	1	1	1	0	0	0	1	1
-----------	---	---	---	---	---	---	---	---

Address B	0	1	0	1	0	1	0	1
-----------	---	---	---	---	---	---	---	---

The result of the ANDF operation is as follows:

Address C	0	1	0	0	0	0	0	1
-----------	---	---	---	---	---	---	---	---

5.28 ORF (logical or)

Function:

The ORF instruction ORFs the contents of address A with a constant (or the contents of address B),and stores the result at address C.

Format:

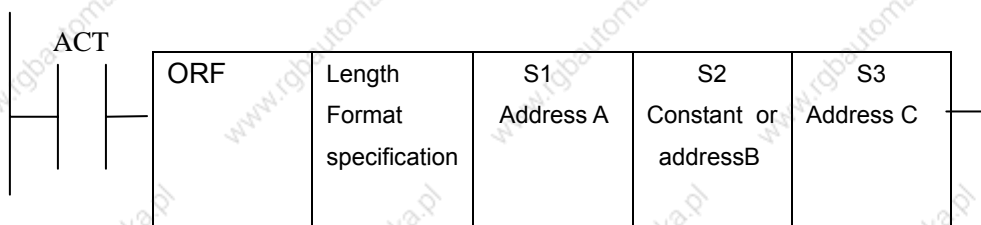

Control conditions:

- ACT=0 : The ORF instruction is not executed.
- ACT=1 : The ORF instruction is executed.

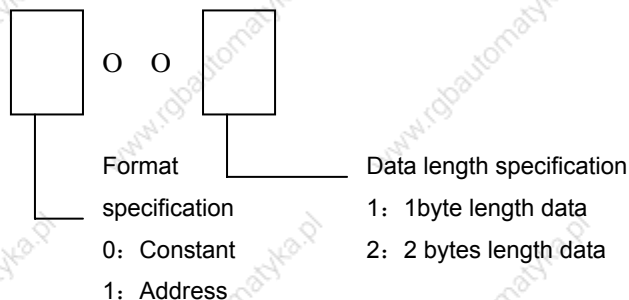

Parameter:

- Length : Specify a data length(1 or 2 bytes), and an input data format(constant or address specification).
- S1 : Specify the input data to ORed. The data that is held starting at this address and has the data length specified in Length format specification is treated as input data.
- S2 : Input data to be ORed with. When address specification is selected in format specification, the data that is held starting at this address and has the data length specified in Length format specification is treated as input data.
- S3 : Address used to store the result of an ORF operation. The result of an ORF operation is stored starting at this address, and has the data length specified in format specification.

Example:

When address A and address B hold the following data:

Address A	1	1	1	0	0	0	1	1
-----------	---	---	---	---	---	---	---	---

Address B	0	1	0	1	0	1	0	1
-----------	---	---	---	---	---	---	---	---

ANDF operates are as follows:

Address C	1	1	1	1	0	1	1	1
-----------	---	---	---	---	---	---	---	---

5.29 NOT (logical not)

Function:

The NOT instruction inverts each bit of the contents of address A, and stores the result at address B.

Format:

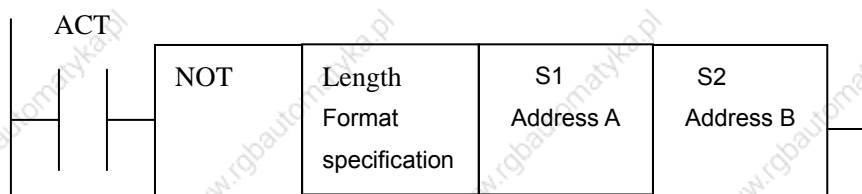

Control condition:

ACT=0: The NOT instruction is not executed.

ACT=1: The NOT instruction is executed.

Parameter:

Length : Specifies a data length(1 or 2 bytes).

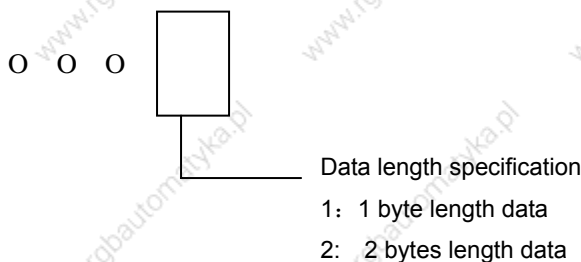

S1 : Input data to be inverted bit by bit. The data that is held starting at this address and has the data length specified in Length format specification is treated as input data.

S2 : Address used to output the result of a NOT operation. The result of a NOT operation is stored starting at this address. And has the data length specified in Length format specification.

Example:

When address A holds the following data:

Address A	1	1	1	0	0	0	1	1
-----------	---	---	---	---	---	---	---	---

The result of the NOT operation is as follows:

Address B	0	0	0	1	1	1	0	0
-----------	---	---	---	---	---	---	---	---

5.30 EOR (exclusive or)

Function:

The EOR instruction exclusive-Ors the contents of address A with a constant(or the contents of address B), and stores the result at address C.

Format:

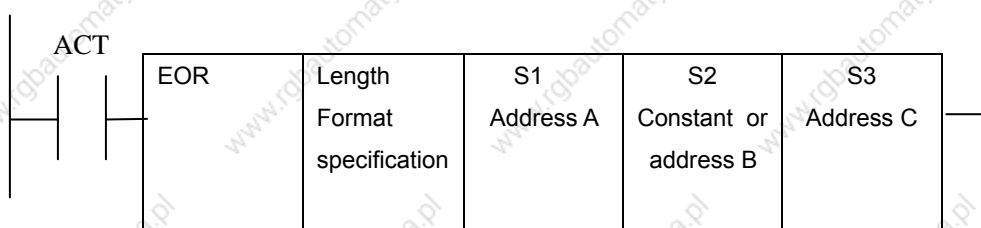

Control conditions:

ACT=0 : The EOR instruction is not executed.

ACT=1 : The EOR instruction is executed.

Parameter:

Length : Specify a data length (1 or 2 bytes) and an input data format(constant or address specification).

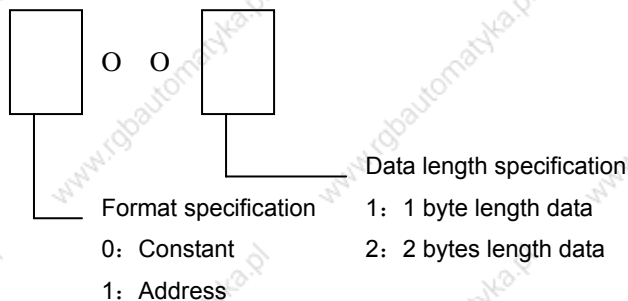

S1 : Input data to be exclusive-ORed. The data that is held starting at this address and has the data length specified in Length format specification is treated as input data.

S2 : Input data to be exclusive-ORed with. When address specification is selected report that specification, the data that is held starting at this address and has the data length specified in Length format specification is treated as input data.

S3 : Address used to store the result of an exclusive EOR operation. The result of an exclusive EOR operation is stored starting at this address, and has the data length specified in Length format specification.

Example:

When address A and B hold the following data:

Address A

1	1	1	0	0	0	1	1
---	---	---	---	---	---	---	---

Address B

0	1	0	1	0	1	0	1
---	---	---	---	---	---	---	---

The result of the exclusive EOR operation is as follows:

Address C

1	0	1	1	0	1	1	0

6 Ladder Writing Limit

1. Sequence program must have END1 and END2 which are taken as the end marks of 1st level and 2nd level sequence part, and END1 must be before END2.
2. They only support the parallel output and do not support the multi-level output.
3. The result output address in all basic instructions and output function instruction are not set the following addresses:
 - (1) Counter preset address DC, timer preset address DT.
 - (2) K0~K5 address are occupied by the system.
 - (3) G63, R255 address are occupied by the system.
 - (4) X address on IO input interface and CNC→PLC F address.

The followings are the phrasing error, and the system will alarm.

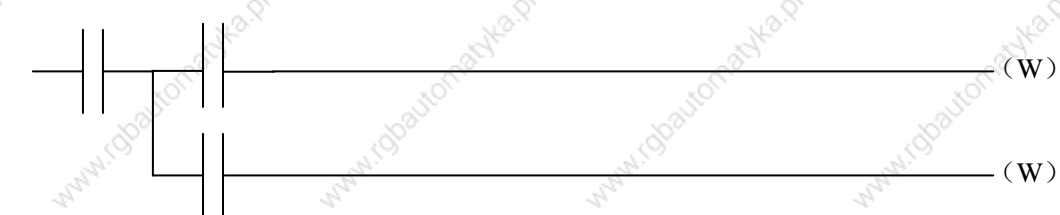
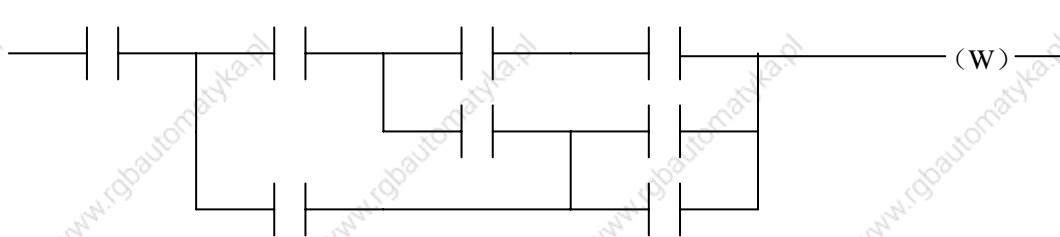
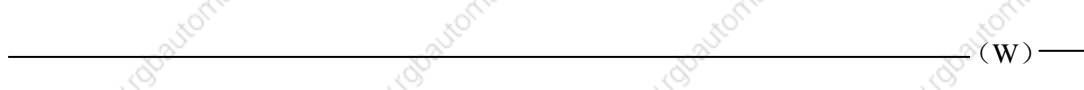
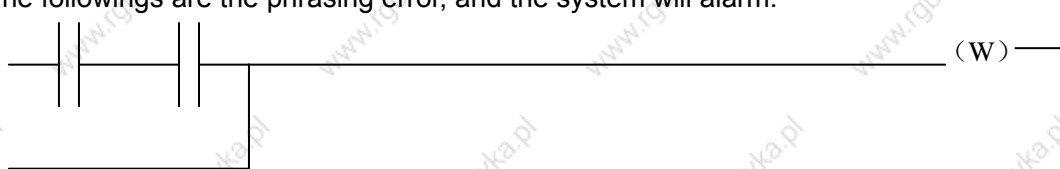

Volume Two Function

1 Controlled Axis

1.1 Outputting of movemtn state of an axis

General The movement state of each axis can be output to the PLC.

Signal Axis moving signals

MV1~MV4 (F017#0~F017#3)

[Classification] Output signal

[Function] These signals indicate that a controlled axis is moving.

MV1: X is moving.

MV2: Y is moving.

MV3: Z is moving.

MV4: A is moving.

[Output conditions]

The signals become 1 when:

- The corresponding axis has started moving.

The signals become 0 when:

- The corresponding axis has stopped moving.

Axis moving direction signals

MVD1~MVD4 (F019#0~F019#3)

[Classification] Output signal

[Function] These signals indicate the movement direction of controlled axis.

MV1: movement direction of X.

MV2: movement direction of Y.

MV3: movement direction of Z.

MV4: movement direction of A.

[Output conditions] When parameter 0003#1~~0003#4 is 1:

“1” indicates the corresponding axes are negatively moving,

“0” indicates the corresponding axes are positively moving.

When parameter 0003#1~~0003#4 is 0:

“0” indicates the corresponding axes are negatively moving,

“1” ndicates the corresponding axes are positively moving.

Caution:

These signals maintain their condition during a stop, indicating the direction of the axes' movement before stopping.

Signal address

	#7	#6	#5	#4	#3	#2	#1	#0
F017					MV4	MV3	MV2	MV1
F019					MVD4	MVD3	MVD2	MVD1

1.2 Servo ready signal

Signal **servo ready signal**
SA (F000#6)

[Classification] Output signal

[Function] After the servo is ready, SA signal becomes 1. For the axis with absorption brake, release the brake when outputting the signal, execute the brake when the system does not output the signal.

Signal address

	#7	#6	#5	#4	#3	#2	#1	#0
F000		SA						

1.3 Servo OFF signal

General Place the controlled axes in the servo off state, stop the current to the servo motor, which disables position control. However, the position check feature functions continuously, so the current position is not lost. These signals are used to prevent the servo motors from overloading when the tools on the axes are mechanically clamped under certain machining, or to move the machine by driving the motors by mechanical MPG.

Signal **servo OFF signal**
SVF1-SVF4<G014>

[Classification] **Input signal**

[Function] Select whether to place each axis in the servo off state. These signals are provided for the controlled axes on a single axis basis. Anumber

appended to a signal represents a controlled axis number.

SVFx

- 1□□1st axis servo OFF
- 2□□2nd axis servo OFF
- 3□□3rd axis servo OFF

[Operation] These signals put the axes for which the signals are 1 in the servo off state(the current to the servo motor is stopped). This disables position control. However, the position detectin feature continues to function, so the current position is not lost.

Signal address

	#7	#6	#5	#4	#3	#2	#1	#0
G014					SVF4	SVF3	SVF2	SVF1

Caution:

1. In general, interlock is applied to an axis while the servo off signal for that axis is 1.
2. When one of these signals becomes 1, the servo motor is turned off. The mechanical clamp is done by using the auxiliary function. Set the timing for the auxiliary function, mechanical clamp and servo off signals as shown in the diagram below. The clamp instruction auxiliary function should be executed only after the distribution end signal(DEN) becomes 1.

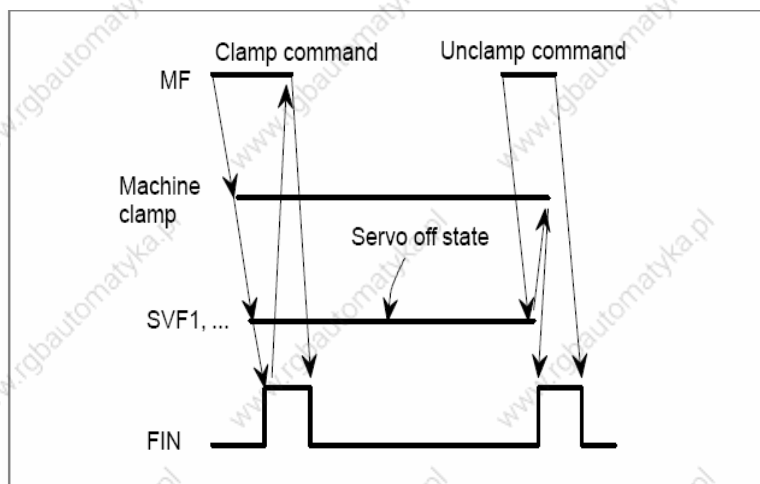

1.4 Mirror image

General Mirror image can be applied to each axis, either by signals or by parameter(setting input is acceptable). All movement directions are reversed during automatic operation along axes to which a mirror image is applied.

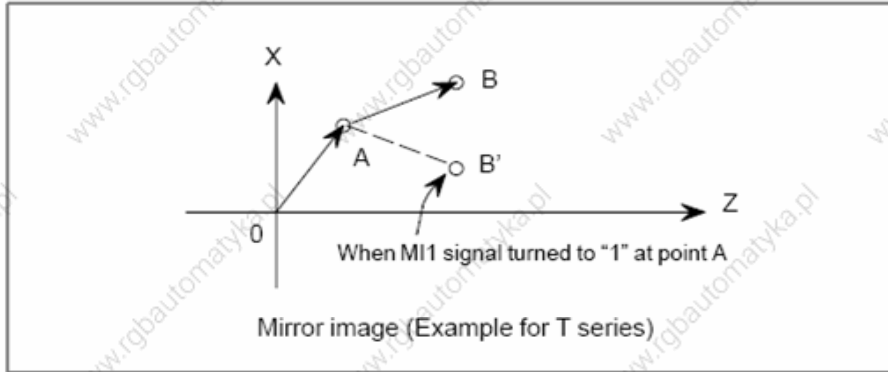

However, the following directions are not reversed:

1. Direction of manual operation and direction of movement, from the intermediate position to the reference point during automatic reference point return.
2. Approach direction for single direction positioning (G60) and shift direction for boring cycles (G76 and G87).

Signal Mirror image signal
MI1—MI4<G010>
 [Classification] Input signal
 [Function] Apply mirror image to the specified axes.
 [Operation] Apply mirror image to those axes for which the signals are 1.
 These signals are provided for the controlled axes on a one-to-one basis.

A number appended to a signal represents the controlled axis number.

- MI x**
- 1: 1st axis mirror image
 - 2: 2nd axis mirror image
 - 3: 3rd axis mirror image

The mirror image signal becomes 1 when:

- a) During offset cancel;
- b) When the CNC is in the automatic operation stop state and not in the feed hold state.

Mirror image check signal
MMI1-MMI4<F020>

[Classification] Output signal
 [Function] These signals indicate the mirror image condition of each axis. The mirror image is set by taking the logical sum of the signal from the MDI panel and the input signal of the machine tool, then relaying the information to the

machine tool.

These signal are provided for every controlled axis. The numeral in the signal name indicates the relevant control axis number.

MMI x

- 1: 1st axis mirror image.
- 2 2nd axis mirror image.
- 3 3rd axis mirror image.

[Output state] The signals are 1 when:

- Mirror image signal Min of the corresponding axis is “1”.
- Mirror image signal of the corresponding axis is turned on by setting data from the MDI panel.

The signals are 0 when:

- Mirror image signal Min of the corresponding axis is “1” and the setting of mirror image in the control unit is turned off.

Signal address

	#7	#6	#5	#4	#3	#2	#1	#0
G010					MT4	MT3	MT2	MT1
F020					MMT4	MMT3	MMT2	MMT1

Parameter

	#7	#6	#5	#4	#3	#2	#1	#0
0001		MIRZ4	MIRZ	MIRY	MIRX			

The following parameter can be set at “Setting screen”.

[Data type] bit axis

Mirror image for MIRx each axis

0: Mirror image is invalid.

1: Mirror image is valid.

Warning :

1. When programmable mirror image and ordinary mirror image are specified at the same time, programmable mirror image is applied first.
2. No programmable mirror image affects mirror image check signal MMI1~MMI4<F020>.

Caution:

Even when the mirror image is applied, instructions which do not actuate mirror image (such as automatic reference point return and manual operation) do not affect mirror image check signals MMI1~MMI4.

Note: When the mirror image is used and mirror image instruction is not executed (automatic reference point return and manual operation), the mirror image check signal MMI1~MMI4 are not influenced.

1.5 Position switch

General Position switch signals can be output to the PMC which the machine coordinates along a controlled axes are within a specified ranges.

Signal position switch signal

PSW01-PSW05

<F014#0 ~ #4>

[Classification] Output signal

[Function] Indicates that the machine coordinates along the controlled axes specified by parameters. Up to 16 position switch signals can be output. (Using 11 or more position switches requires setting the ESP parameter.)

[Output conditions] The signals are 1 when:

The machine coordinate along the controlled axes are within the specified range.

These signals are 0 when:

The machine coordinate along the controlled axis are not within the specified range.

Signal address

	#7	#6	#5	#4	#3	#2	#1	#0
F014				PSW05	PSW04	PSW03	PSW02	PSW01

2 Preparation for Operation

2.1 Emergency stop

General If you press Emergency Stop button on the machine operator's panel, the machine movement stops in a moment.

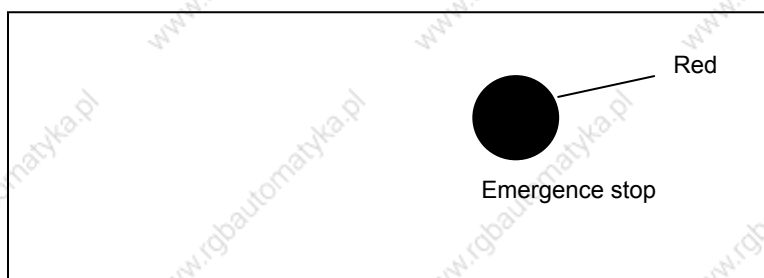

The button is locked when it is pressed, Although it varies with the machine too builder, the button can usually be unlocked by twisting it.

Signal Emergency stop signal

***ESP (X001.4 G001.0)**

[Classification] Input signal

[Function] Activating an emergency stop signal stops the machine instantly.

[Operation] When the emergency stop *ESP becomes 0, the emergency stop is applied to the machine and the CNC is reset.

Signal address

	#7	#6	#5	#4	#3	#2	#1	#0
X001				*ESP				
G001								*ESP

2.2 CNC ready signal

General When the CNC is turned on and become ready for operation, the CNC ready signal is set to 1.

Signal CNC ready signal

MA (F001 #7)

[Classification] Output signal

[Function] The CNC ready signal indicates that the CNC is ready.

[Output conditions] When the CNC is turned on and becomes ready for operation, the signal is set to 1. Normally, it takes several seconds to establish this state after the power is turned on. If a system alarm is issued, the signal is set to 0. The signal remains set to 1, however, when an emergency stop or a similar operation is performed.

Address

	#7	#6	#5	#4	#3	#2	#1	#0
F001	MA							

2.3 CNC overtravel signal

General When the tool tries to move beyond the stroke end set by the machine tool limit switch, the tool decelerates and stops as a result of tripping the limit switch, and an Over TRAVEL is displayed. The signal can be output with an alarm.

Signal Overtravel signal

+L1~+L4(G12#0~G12#3)

-L1~-L4(G13#0~G13#3)

[Classification] Input signal

[Function] Indicates that the control axis has reached its stroke limit. There are individual signals for each direction in every control axis.

The + /- in the signal name indicate the direction and the number corresponds to the control axis.

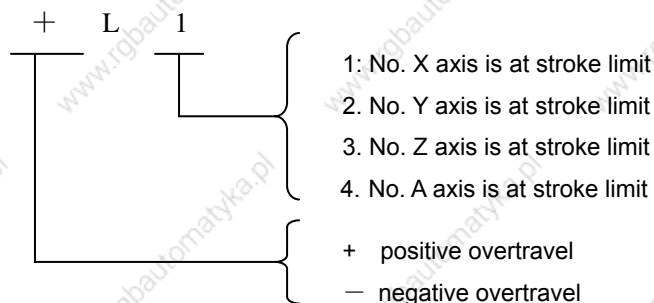

[Operations] "0": the controlled unit operates as follows:

Automatic operation: If even one axis overtravel signal becomes, all axes are decelerated to stop, an alarm is given and operation is halted.

Manual operation: Only the axis whose overtravel signal has

becomed 0 is decelerated to a stop, and the axis an be moved in the opposite direction.

Once the axis overtravel signal has become 0, the axis direction is registered. Even if the signal returns to 1, it is not possible to move that axis in that direction until the alarm is cleared.

Signal address

	#7	#6	#5	#4	#3	#2	#1	#0
G012					+L4	+L3	+L2	+L1
G013					-L4	-L3	-L2	-L1

2.4 Alarm signal

General When an alarm is triggered in the CNC, the alarm is displayed on the screen, and the alarm signal is set to 1. If the voltage level of the memory backup battery falls to below a specified level while the CNC is turned off, the battery alarm signal is set to 1.

Signal Alarm signal

AL (F001 #0)

[Classification] Output signal

[Function] Alarm signal reports CNC is in an alarm state as follows:

- a) TH alarm
- b) TV alarm
- c) P/S alarm
- d) Overtravel alarm
- e) Overheat alarm
- f) Servo alarm

[Output conditions] These alarm signal is set to 1 when:

—The CNC is placed in the alarm state.

These alarm signals is set to 0 when:

—The alarm has been released by resetting the CNC.

Signal address

	#7	#6	#5	#4	#3	#2	#1	#0
F001								AL

2.5 Machine ready signal

General report the machine has been the ready state.

Signal machine ready signal

MRDY (G009#4)

[Classification] Input signal

[Function] Must input the signal when CNC automatically runs.

[Operation] MRDY signal becomes 1 without the alarm signal.

2.6 Interlock activation

General These signals disable machine movement along axes. When any of these signals is activated during movement, tool movement is decelerated, and then stopped.

All axes interlock signal

***IT1~*IT4(G015#0~G015#3)**

[Classification] Input signal

[Function] This signal is used to inhibit the machine from moving. The number at the end of each signal name denotes the number of the corresponding controlled axis.

*IT1	No. X axis interlock
*IT2	No. Y axis interlock
*IT3	No. Z axis interlock
*IT4	No. A axis interlock

[Operation] a) In manual operation:

The movement of an interlocked axis is inhibited, but the other axes are movable. If an axis is interlocked during movement, it stops after being decelerated, and it starts moving again when it is released from interlock.

b) In automatic operation

If an axis is interlocked while its movement is being commanded (the move amount is not 0, inclusive of the tool offset), movement in all axes is prevented.

If a moving axis is interlocked, all axes stop moving after being

decelerated, and they start moving again when interlock is released.

This function is also effective during dry run.

Signal address

	#7	#6	#5	#4	#3	#2	#1	#0
G009				MRDY				
G015					*IT4	*IT3	*IT2	*IT1

2.7 Mode selection

Signal mode check signal
F003#0~F003#7
 [Classification] Output signal
 [Function] Report the current selected operation mode

Signal address

	#7	#6	#5	#4	#3	#2	#1	#0
F003	MZRO	MEDT	MMEM	MRMT	MMDI	MJ	MH	MINC

2.8 Status output signal

Signal Rapid traversing signal
RPDO (F002#1)
 [Classification] Output signal
 [Function] This signal indicates that a move instruction is being executed at the rapid traverse.

- [Output conditions:]
- 1: indicates an axis starts moving after rapid traverse has been selected;
 - 0: indicates that an axis starts moving after a federate other than rapid traverse has been selected. This holds true for both automatic and manual operation modes.

Cutting feed signal
CUT (F002#6)
 [Classification] Output signal
 [Function] These signals indicate that the cutting feed is being performed by

automatic operation.

[Output conditions] These signals are 1 when:

When cutting feed is being performed by automatic operation(cutting feed for linear interpolation, circular interpolation, helical interpolation, thread cutting, skip cutting, or cutting in canned cycle).

Note:

Do not output the signal in the state of feed hold.

Output the signal during the interlock or the feedrate override is set to 0.

Signal address

	#7	#6	#5	#4	#3	#2	#1	#0
F002		CUT					RPDO	

2.9 VRDY OFF alarm ignore signal

General The German VDE safety standard requires that the motor be deactivated when the safety guard is opened. By using the VRDY OFF alarm ignore signal, however, the CNC can be restarted without resetting, even if the safety guard has been opened.

Signal **All-axis VRDY OFF alarm ignore signal**
IGNVRY<G009#3>

[Classification] Input signal

[Function] Disables the check of servo alarm VRDY OFF.

[Operation] When the signal is set to logical 1, the control unit operates as follows:

Even when the servo amplifier ready signal goes off, the control unit, however, sets ervo ready signal SA to 0. The SA signal can remain set to 0.

Signal address

	#7	#6	#5	#4	#3	#2	#1	#0
G009					IGNVRY			

2.10 Abnormal load check

General Machine collision, defective, and damaged tools cause a large load torque on the

servo and spindle motors, compared with normal rapid traverse or cutting feed. This function detects the load torque on the motors and sends this value as an estimated load torque to the PMC. If the detected load torque value is abnormally great compared with the value specified in the parameter, the function stops the servo motor as early as possible or reverses the motor by an appropriate value specified in a parameter, in order to minimize possible damage to the machine. (The function to reverse motors is effective only for servo motors.)

Abnormal load check function is divided as follows:

- (1) Estimated load torque function
 The CNC is always calculating the estimated load torque for the motor(excluding acceleration/deceleration torque).
 The estimated load torque output function enables the PMC to read the calculated torque using the window function.
- (2) Abnormal load check alarm function
 This function stopss motors or reverses them by an amount specified in a parameter, causing the CNC to output an alarm, whenever the load torque obtained by the estimated load torque output function is greater than the value specified in a parameter. (The function to reverse motors is effective only for servo motors.)
 Use the abnormal load check function parameter (ABDSW) and abnormal load. The check ignores the signal IUDD1—IUDD4 to make the abnormal load check function of one axis is enabled or disabled.

Signal: Servo axis abnormal load detected signal
ABTQSV<F015#0>
[Classification] Output signal
[Function] Report PMC that the abnormal load on a servo axis was detected.
[Output conditions] These signals are 1 when:
 An abnormal load is deteced for a servo axis, Cs axis, spindle positioning axis, or spindle axis during rigid tapping.

Spindle abnormal load detected signal
ABTSP<F015#1>
[Classification] Output signal
[Function] Report PMC that the abnormal load on the spindle has been detected.
[Output conditions] These signals are 1 as follows:

The abnormal load was detected on the spindle in the speed control mode.

Signal address

	#7	#6	#5	#4	#3	#2	#1	#0
F015					80		ABTSP	ABTQS

3 Manual Operation

3.1 JOG feed/incremental feed

General

JOG feed In JOG mode, setting a feed axis and direction selection bit to 1 on the machine operator's panel moves the machine along the selected axis in the selected direction.

Incremental feed In incremental feed mode, setting a feed axis and direction selection bit to 1 on the machine operator's panel moves the machine one step along the selected axis in the selected direction. The minimum distance the machine moves, is the least input increment. The step can be 10, 100, or 1000 times the least input increment.

The only difference between JOG feed and incremental feed is the method of selecting the feed distance. In JOG feed, the machine continues to be fed while the following signals selecting the feed axis and direction are 1: +J1, -J1, +J2, -J2, +J3, -J3, etc. In incremental feed, the machine is fed by one step. Using JOG feedrate override dial can regulate JOG feedrate. The step distance can be selected by MPG feed movement distance G026#0~G026#3.

Signal Feed axis and direction selection signal

+J1~+J4 (G27#0~G27#3)

-J1~-J4 (G28#0~G28#3)

[Classification] Input signal

[Function] In JOG feed or Incremental feed mode, select the required feed axis and direction. +/- in the signal name indicates the feed direction, the number corresponds to the controlled axis.

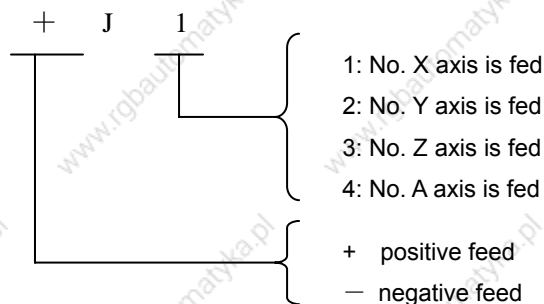

[Operation] When the signal is set to 1, the control unit operate as follows:

When JOG feed or incremental feed is allowed, the control unit moves the specified axis in the specified direction.

When the signal is set to 1 in JOG feed, the control unit continues to feed tha axis while the signal is set to 1.

In incremental feed, the control unit feeds the requested axis by the step distance which is specified by the manual handle feed move distance selection signal, then the axis stops. Even if the signal si set to 0 while the axis is being fed, the contol unit does not stop moving.

To feed the axis again set the signal to 0, then to 1 again.

Manual rapid traverse selection signal

RT (G024#7)

[Classification] Input signal

[Function] Select the rapid traverse rate in JOG feed or incremental feed mode.

[Use] When the signal becomes 1, the control unit operates as follows:

- The control unit executes the jog feed or incremental feed at a rapid traverse rate. The rapid traverse override is validated.
- When the signal is switched from 1 to 0 or vice versa in jog feed or incremental feed, the feedrate is decelerated until it reaches zero, then increased to the specified value. During acceleration and deceleration, the feed axis and direction selection signal can be kept 1.

Signal address

	#7	#6	#5	#4	#3	#2	#1	#0
G024	RT							
G027					+J4	+J3	+J2	+J1
G028					-J4	-J3	-J2	-J1

3.2 MPG(Handwheel) feed

General In MPG feed mode, the machine movesby rotaing the manual pulse generator(MPG). Select the axis along which the machine moves with the MPG feed axis selection signal.

Signal (G027#0~G027#3)
 [Classification] Input signal
 [Function] Select the MPG feed axis

Signal **MPG/Incremental select signal**
 (G026#0~G026#3)
 [Classification] Input signal
 [Function] When the signal selects the MPG feed, MPG generates the movement distance of every pulse which also can select the movement distance per step of incremental feed .

3.3 MPG interruption

General Rotating MPG during automatic operation can increase the distance traveled by the amount corresponding to the MPG feed. The axis to which the MPG interrupt is applied is selected using the manual MPG interrupt axis select signal.

Signal **MPG interrupt axis selection signal**
HS1IA-HS1ID<G004#0-#3>
[Classification] Input signal
[Function] These signals select an axis to which the manual MPG interrupts is applied. There are three sets of signals, each corresponding to a MPG (up to two). Each set consists of 4 signals A, B, C, and D. The number in each signal name corresponds to the number of MPG.

HS 1 IA

- 1 Select the axis for which MPG No. 1.
- 2 Select the axis for which MPG No. 2.

The correspondence between the code signals A, B, C, D and the selected feed axis is similar to the correspondence of MPG feed axis select signals. See 3.2 MPG Feed.

Signal address

	#7	#6	#5	#4	#3	#2	#1	#0
G004					HS1ID	HS1IC	HS1IB	HS1IA

Warning:

The distance traveled by MPG interruption is determined accordint to the amount by which the MPG is turned and the MPG override (×1, 10, ×m, ×n).

Since the movement is not accelerated or decelerated, it is very dangerous to use a large override value for MPG interruption.

Note:

1. MPG interrupt cannot be used in MPG feed mode.
2. MPG interruption is disabled when the machine tool is locked or interlocked.

4 Reference Point Return

4.1 Manual reference point return

General In manual reference point return mode, the machine tool move in the specified direction by setting the position parameter N0: 7#3~#7 to execute the reference point return. The selected axis on the panel reports the axis to execute the machine zero return, which is not related to the move direction of axis.

The following signals are related to the manual reference point return:

	Manual reference point return
Selection of reference point return	MREF
Reference point return deceleration signal	DECX,DECY,DECZ,DECA
Reference point return completion signal	ZP1,P2, ,ZP3,ZP4
Creating reference point signal	ZRF1,ZRF2,ZRF3,ZRF4

Signal Manual reference point return selection check signal

MREF (F004#5)

[Classification] Output signal

[Function] The signal indicates the manual reference point return had been selected once.

[Output conditions] When the signal becomes 1 :

- * The manual reference point return had been selected.

When the signal becomes 0:

- * The selection of manual reference point return has terminated.

Reference point return end signals

ZP1~ZP4(F016#0~F016#3)

[Classification] Output signal

[Function] These signals report that the machine tool is at the reference point on a controlled axis.

These signals correspond separately to all axes.

ZP1	No. X axis reference point return end signal.
-----	---

ZP2	No. Y axis reference point return end signal.
ZP3	No. Z axis reference point return completion signal.
ZP4	No. A axis reference point return completion signal.

[Output conditions] When these signals becomes 1:

- Manual reference point return is completed and the current position is in the in-position area.
- The automatic reference point return(G28) is completed and the current position is in the in-position area.
- The reference point return check is completed and the current position is in the in-position area.

When the signal becomes 0:

- The machine tool moves from the reference point.
- The emergency stop signal appears.
- The servo alarm appears.

Reference point return deceleration signal

DECX (X01#0) DECY (X01#1) DECZ (X01#2) DECA (X01#3)

[Classification] Input signal

[Function] These signals decelerate the feedrate for manual reference point return to a low feedrate.

Reference point return deceleration signal check

DECX (G017#0) DECY (G017#1) DECZ (G017#2) DECA (G017#3)

[Classification] Input signal

[Function] These signals decelerate the feedrate for manual reference point return to a low feedrate.

Reference point establishment signal

ZRF1~ZRF4(F060#0~F060#3)

[Classification] Output signal

[Function] These signals report the system that the reference point has been established.

These signals correspond separately to all-axis.

ZRF1	No. X axis reference point establishment signal
ZRF2	No. Y axis reference point establishment signal
ZRF3	No. Z axis reference point establishment signal
ZRF4	No. A axis reference point establishment signal

[Output conditions] These signals become 1 when:

- The reference point has been established after manual reference

point return.

- When the reference point is established using the absolute-position detector at initial power-on.

These signals become 0 when:

- The reference point is lost.

Signal address

	#7	#6	#5	#4	#3	#2	#1	#0
X001					DECA	DECZ	DECY	DECX
F004			MREF					
F016					ZP4	ZP3	ZP2	ZP1
F060					ZRF4	ZRF3	ZRF2	ZRF1
G017					DECA	DECZ	DECY	DECX

Parameter

	#7	#6	#5	#4	#3	#2	#1	#0
0004								JAX

[Data Classification] bit

JAX Number of axes controlled simultaneously in JOG feed, manual rapid traverse and manual reference point return.

- 0: multi-axis
- 1: single axis

	#7	#6	#5	#4	#3	#2	#1	#0
0006								ZRN _x

[Data type] bit-axis

ZRN_x When a instruction specifying the movement(except for G28) is issued in automatic operation(MEM, RMT or MDI) before referencing is completed.

- 1: An alarm is generated (P/S alarm 224).
- 0: No alarm is generated.

Note: When the parameter is changed, the power supply must be turned off before operation and then is turned on again.

	#7	#6	#5	#4	#3	#2	#1	#0
0007	ZMI5	ZMI4	ZMIz	ZMIy	ZMIx			

[Data Classification] bit-axis

ZMI Direction of reference point return

0: positive direction

1: negative direction

	#7	#6	#5	#4	#3	#2	#1	#0
0009						ZCL		

[Data Classification] Bit

ZCL Local coordinate system after the manual reference point return is executed.

0: The local coordinate system is not canceled.

1: The local coordinate system is canceled.

Note: After setting the parameter, the power supply must be turned off, and the parameter will take effect after restart.

5 Automatic Operation

5.1 Cycle start/feed hold

General

Start of automatic Operation(cycle start) When automatic operation start signal ST is set to 1 then 0 while the CNC is in memory mode, DNC operation mode or MDI mode, the CNC enters the automatic operation start state then starts operating.

The signal ST is ignored as follows:

1. When the CNC is in other modes except for MEM, RMT or MDI mode.
2. When the feed hold signal (SP) is set to 0.
3. The emergency stop signal (ESP) is set to 0.
4. When the external reset signal (ERS) is set to 1.
5. When <RESET> on MDI panel is pressed.
6. When CNC is in the state of alarm.
7. When the automatic operation is started.
8. When the program restart signal (SRN) is set to 1.
9. When CNC is searching one sequence number.

The CNC enters the feed hold state and stops operation in automatic operation as follows:

In automatic operation, the CNC enters the feed hold and stops running as follows:

1. When the feed hold signal (SP) is set to 0.
2. When the mode is changed to manual operation mode.

In automatic operation, the CNC enters the feed hold and stops running as follows:

1. The single block instruction is end when the single block is running.
2. MDI operation is completed.
3. CNC alarms.
4. The single block instruction is end after the mode is changed to others or Eidt mode.

In automatic operation, the CNC enters the reset and stops running as follows:

1. When the emergency stop signal (ESP) is set to 0.
2. When the external reset signal (ERS) is 1.
3. When <RESET> on MDI panel is pressed.

* Halt of automatic operation

(Feed hold)

When the feed hold signal SP is set to 0 in automatic operation, the CNC enters the feed hold state and stops operation. At the same time, cycle start lamp signal STL is set to 0 and feed hold lamp signal SPL is set to 1. Re-setting signal SP to 1 in itself will not restart automatic operation. To restart automatic operation, first set signal SP to 1, then set signal ST to 1 and to 0.

When signal SP is set to during the execution of a block containing only the M, S, T function, signal STL is immediately set to 0, signal SPL is set to 1, and the CNC enters the feed hold state. If the FIN signal is subsequently set from the PMC, the CNC executes processing up until the end of the block that has been halted. Upon the completion of that block, signal SPL is set to 0 (signal STL remains set to 0) and the CNC enters the automatic operation stop state.

1. Thread cutting

In the thread cutting, when the signal SP is set to 0, CNC enters the feed pasue after the signal SP is set to 0.

In G92 (thread cutting cycle), SP signal is set to 0, SPL signal immediately becomes 1 but the operation is continuously executed till the tool retraction is completed after the thread cutting.

In G32(thread cutting), SP signal is set to 0, SPL signal immediately becomes 1 but the operation is continuously executed till the non thread cutting block is completed after the thread cutting blok.

2. Tapping in canned cycle

In G84 (canned cycle tapping) SP signal is set to 0, SPL signal immediately becomes 1. But the operation is continuously executed till the tool returns to the starting point or R point after the tapping is completed.

3. A macro instruction is being executed

Operation stops after the currently executing macro instruction has been completed.

Signal **Cycle start signal**
ST (G023#6)
 [Type] Input signal

[Function] Start the automatic operation.

[Operation] When signal ST is set to 1 then 0 in automatic operation(Auto), DNC and MDI mode, the CNC enters the cycle start state and starts operations.

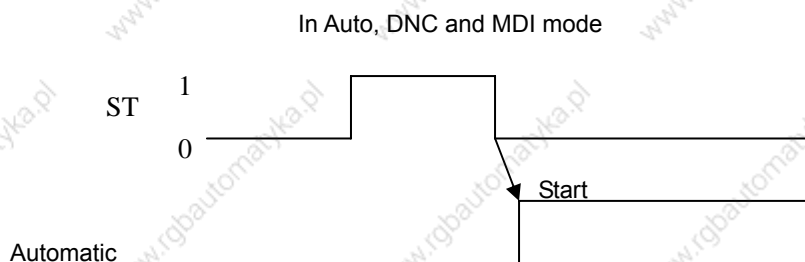

Feed hold signal
SP (G023#7)

[Classification] Input signal

[Function] Halt the automatic operation

[Operation] In Auto mode, SP signal is set 0, CNC enters the feed hold and stops running. When SP signal is set to 0, the automatic operation does not start.

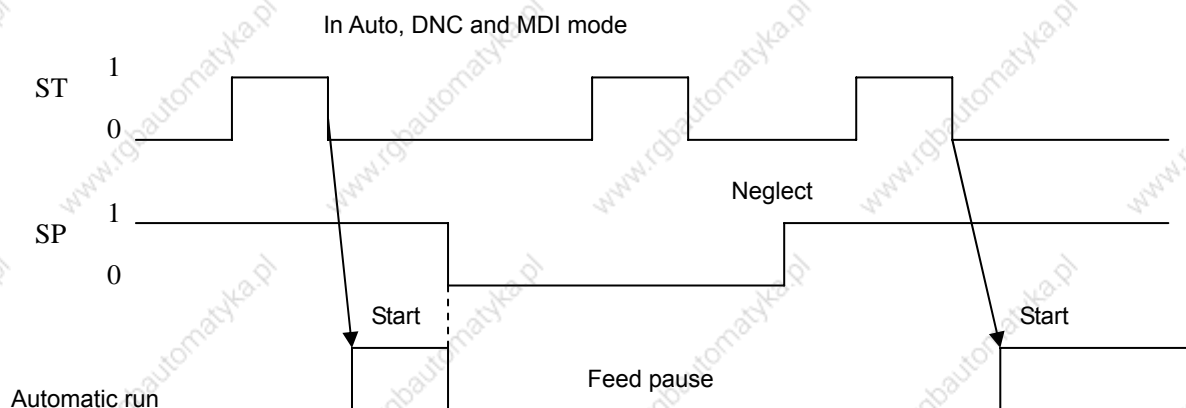

Cycle start lamp signal

STL (F000#5)

[Classification] Output signal

[Function] The signal reports PLC that the automatic operation start is entered.

[Output conditions] The signal is set to 1 or 0, which is determined by CNC state as Fig. 5.1.

Feed hold lamp signal

SPL (F000#4)

[Classification] Output signal

[Function] The signal reports PLC that the feed hold is entered.

[Output conditions] The signal is set to 1 or 0, which is determined by CNC state as Fig. 5.1.

Automatic operation signal

OP (F000#7)

[Classification] Output signal

[Function] The signal reports PLC that the automatic operation is entered.

[Output conditions] The signal is set to 1 or 0, which is determined by CNC state as Fig. 5.1.

	Cycle start lamp STL	Feed hold lamp SPL	Automatic operation lamp OP
Cycle start	1	0	1
Feed hold	0	1	1
Automatic operation stopping	0	0	0
Reset	0	0	0

Table 5.1

Signal address

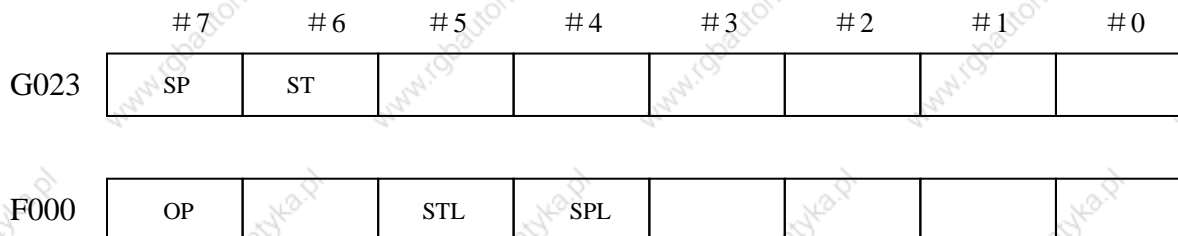

5.2 Reset

General

CNC is reset and enters the reset state.

1. When the emergency signal (ESP) is set to 0.
2. When the external reset signal (ERS) is set to 1.
3. When <RESET> on MDI panel is pressed.

When the CNC is reset, the resetting signal RST is output to the PMC. The resetting signal RST is set to 0 when the resetting signal output time, set by No. 203, has elapsed after the above conditions have been released.

$$RST = T_{reset} (\text{Reset processing time}) + \text{parameter setting value by No. 203}$$

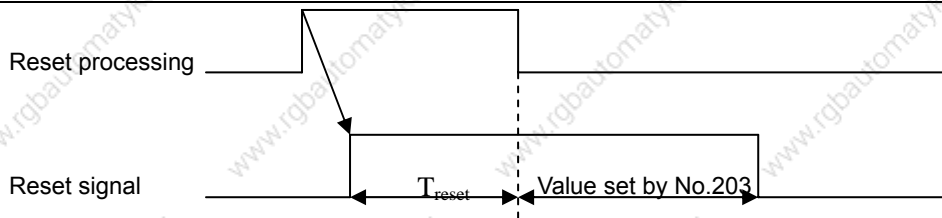

When the CNC is reset in automatic operation, the automatic operation is stopped and tool movement along the controlled axis is decelerated and stopped. When the CNC is reset during the execution of the M, S, T function, signal MF, SF or TF is set to 0 within 16ms.

Signal External reset signal

ERS (G016#0)

[Classification] Input signal

[Function] Reset CNC

[Operation] When the reset signal ERS is set to 1, CNC enters the reset state.

The reset signal RST becomes 1 after CNC is reset.

Rset signal

RST (F001#1)

[Classification] Output signal

[Function] The signal reports PLC that CNC is reset.

[Output conditions] The signal is set to 1 when:

- 1: When the emergency stop signal (ESP) is set to 0.
- 2: When the external reset signal (ERS) is set to 1.
- 3: When <RESET> on MDI panel is pressed.

The signal is set to 0 when:

When the reset signal output time set by No. 71# is completed after the above are released and CNC is reset.

Signal address

	#7	#6	#5	#4	#3	#2	#1	#0
G016								ERS
F001							RST	

5.3 Testing a program

General Before machining is started, the automatic running check can be executed. It checks whether the established program can operate the machine as desired. This check can be accomplished by running the machine or view the position display change without running the machine.

5.3.1 Machine tool lock

General The change of the position display can be monitored without moving the machine. When all-axis machine lock signal MLK, or each-axis machine lock signals MLK1~MLK4 are set to 1, output pulses to the servo motors are stopped in manual or automatic operation. The instructions are distributed, however, updating the absolute and relative coordinates. The operator can therefore check if the instructions are correct by monitoring the position display.

Signal all-axis machine lock signal

MLK1~MLK4(G011 # 0~G011 # 3)

[Classification] Input signal

[Function] Place the corresponding controlled axes in the machine lock state.

The signal number corresponds to the number of the controlled axis.

MLK 1	No. X axis machine tool lock
MLK 2	No. Y axis machine tool lock
MLK 3	No. Z axis machine tool lock
MLK 4	No. A axis machine tool lock

[Operation] When these signals are set to 1, pulse are not output to the servo motors for the corresponding axes in manual or automatic operation mode.

All-axis machine lock check signal

MMLK (F004 # 1)

[Classification] Output signal

[Function] The signal reports PLC of the state of all-axis machine tool lock signal.

[Output condition] When the signal is set to 1, all-axis machine tool lock signal is set to 1.

When the signal is set to 0, all axes machine tool lock signals are

set to 0.

Signal address

	#7	#6	#5	#4	#3	#2	#1	#0
F004							MMLK	
G011					MLK4	MLK3	MLK2	MLK1

5.3.2 Dry run

General Dry run is valid only for automatic operation. The machine moves at a constant feedrate regardless of the feedrate specified in the program. The feedrate is set by P0096.

This function is used to check the movement of the machine without a workpiece.

Signal Dry run signal

DRN (G021 #2)

[Classification] Input signal

[Function] Enables dry run.

[Operation] When the signal is set to 1, the machine tool moves at the feedrate specified for dry run.

When the signal is 0, the machine tool normally moves.

Caution:

When the dry run signal is changed from 0 to 1 or 1 to 0 during the movement of the machine, the feedrate of the machine is first decelerated to 0 before being accelerated to the specified feedrate.

Dry run check signal

MDRN (F002 #7)

[Classification] Output signal

[Function] The signal reports PLC of the state of dry run signal.

[Operation] These signals are set to 1 as follows:

—When the dry run signal DRN is set to 1.

These signals are set to 0 as follows:

—When the dry run signal DRN is 0.

Signal address

	#7	#6	#5	#4	#3	#2	#1	#0
G021						DRN		
F002	MDRN							

5.3.3 Single block

General The single block operation is valid in automatic operation mode (Auto mode).

When the single block signal (SBK) is set to 1 during automatic operation, the CNC enters the automatic operation stop state after executing the current block. In subsequent automatic operation, the CNC enters the automatic operation stop state after executing each block in the program. When the single block signal (SBK) is set to 0, normal automatic operation is stored.

Signal Single block signal

SBK (G021 #1)

[Classification] Input signal

[Function] Enables single block operation.

[Operation] Execute the single block when the signal is set to 1.

Execute the normal operation when the signal is set to 0.

Single block check signal

MSBK (F004 #3)

[Classification] Output signal

[Function] The signal reports PLC of the state of single block signal.

[Operation] The signal is set to 1 as follows:

——When the single block signal SBK is set to 1.

The signal is set to 0 as follows:

——When the single block signal SBK is set to 0.

Note:

1. Operations in thread cutting

When the SBK signal becomes 1 in thread cutting, the operation stops after the first non-thread cutting signal after thread cutting instruction.

2. Operation in canned cycle

When the SBK signal becomes 1 during canned cycle operation, the operation stops at each positioning, approach, drilling and retraction instead of the end of the

block. The SPL signal becomes 1 while the STL signal becomes 0, showing that the end of the block has not been reached. When the execution of one block is completed, the STL and SPL signals becomes 0 and the operation is stopped.

Signal address

	#7	#6	#5	#4	#3	#2	#1	#0
G021							SBK	
F004					MSBK			

5.4 Optional block skip

General When a slash followed by a number is specified at the head of a block, and optional block skip signal BDT is set to 1 during automatic operation, the block is ignored.

Signal Skip optional block signal

BDT (G021#0)

[Classification] Input signal

[Function] Select whether a block with “/” is neglected.

[Operation] During automatic operation, when BDT is 1, the block with “/” is neglected.

The program is normally executed when BDT is 0.

Optional block skip check signal

MBDT (F004#0)

[Classification] Output signal

[Function] The signal reports PMC of the state of skip optional block BDT.

Signal address

	#7	#6	#5	#4	#3	#2	#1	#0
G021								BDT
F004								MBDT

5.5 Program restart

General A program may be restarted at a block by specifying the sequence number of the block, after automatic operation is stopped because of a broken tool or for holidays.

There are two types of restart method as follows:

- P : restart after a tool is broken down
- Q : restart after holidays

Signal Program restart signal

SRN<G021#6>

[Classification] Input signal

[Function] Select the program restart

[Operation] When the program restart signal is set to 1 to search for the sequence number of the block to be restarted, the CRT screen changes to the program restart screen. When the program restart signal is set to 0, and automatic operation is activated, the machine moves back to the machining restart point at dry run speed along the axes one by one. When the machine moves to the restart point, machining restarts.

Signal during program restart

SRNMV<F002#4>

[Classification] Output signal

[Function] Report the program is started.

[Output conditions] The signal becomes 1 when:

- After CRT screen is switched to the restart screen, the program restarting signal is set to 0.

The signal becomes 0 when :

- The program restart sequence ends(all controlled axes of machine tool moves to the restart point).

Signal address

	# 7	# 6	# 5	# 4	# 3	# 2	# 1	# 0
G021		SNR						
F002				SRNM				

6 Interpolation Function

6.1 Thread cutting

6.1.1 Thread cutting

General Tool movement can be synchronized with spindle rotation when cutting threads.

The spindle speed is continuously read through the position coder attached to the spindle. Then, it is converted to a cutting federate (feed per minute) to feed the tool.

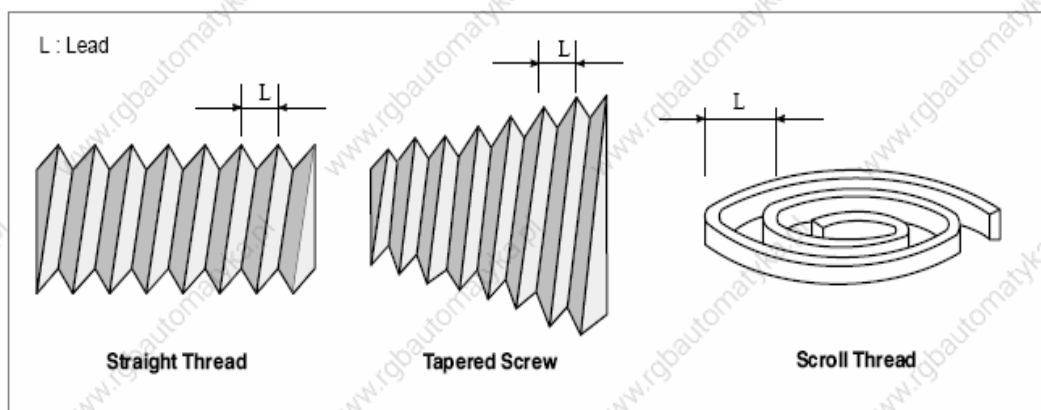

During general, thread cutting is repeated along the same tool path during rough cutting through finish cutting for a screw. Since thread cutting starts when the position coder mounted on the spindle outputs a 1-turn signal, threading is started at a fixed point and the tool path on the workpiece is unchanged for repeated thread cutting. Note that the spindle speed must remain constant from rough cutting through finish cutting. If not, incorrect thread lead will occur.

Signal Thread cutting signal

THR D<F002#3>

[Function] This signal indicates that thread cutting is during progress.

[Output conditions] The signal is "1" when:

- During thread cutting mode
- Thread cutting cycle mode

The signal is "0" when:

- Neither thread cutting mode nor thread cutting cycle mode.

Signal address

	#7	#6	#5	#4	#3	#2	#1	#0
F002					THR D			

7 Feedrate Control

7.1 Rapid traverse rate

General A rapid traverse rate is set for each axis by P0088~0092, so no rapid traverse rate need be programmed. The following overrides can be applied to a rapid traverse rate with the rapid traverse override signal:

F0, 25%, 50%, 100%.

F0 : it is set by the data parameter P0093.

Signal **Rapid traversing signal**

RPDO (F002#1)

[Classification] Output signal

[Function] This signal indicates that a move instruction is executed at rapid traverse.

[Output conditions] 1: indicates that an axis starts moving after rapid traverse has been selected.

0: indicates that an axis starts moving after a feedrate other than rapid traverse has been selected. This hold true for both automatic and manual operation modes.

Note:

1. The rapid traverse during automatic operation includes all rapid traverses during canned cycle positioning, automatic reference point return, etc., as well as the move instruction G00. the manual rapid traverse also includes the rapid traverse during reference point return.
2. Once rapid traverse has been selected, this signal remains “1”, including during a stop, until another feedrate has been selected and movment is started.

Signal address

	#7	#6	#5	#4	#3	#2	#1	#0
F002							RPDO	

7.2 Advanced preview control

General This function is designed for high-speed precise machining. With this function, the delay due to acceleration/deceleration and the delay during the servo system which

increase with the feedrate can be suppressed. The tool can then follow specified path accurately and errors during the machining profile can be reduced.

This function becomes effective when advanced preview control mode as follows:

- (1) Linear acceleration/deceleration before interpolation for cutting feed
- (2) Automatic corner deceleration function

Signal Advanced preview control mode signal

G08MD<F013#0>

[Classification] Output signal

[Function] Inform that the control is during the advanced preview control mode.

[Output conditions] The signal is “1” when:

- During advanced preview control mode

The signal is “0” when:

- It is not during advanced preview control mode

Signal address

	#7	#6	#5	#4	#3	#2	#1	#0
F013								G08MD

7.3 In-position check

General Whether the position of the servo motor is within a specified range is checked. If the in-position check function is enabled, the CNC checks the position during deceleration. If the position is found to exceed the specified range, the CNC does not execute the next block.

Signal **In-position signal**

INP1~INP4<F018>

[Classification] Output function

[Function] These signals indicate that the control axes are set to the in-position condition.

They are provided for each control axis, and the number during the signal name corresponds to the control axis number.

INPx

- 1---1st axis is set to the in-position condition
- 2---2nd axis is set to the in-position condition
- 3---3rd axis is set to the in-position condition
- 4---4th axis is set to the in-position condition

[Output conditions] These signals become “1” when:

The servo error of the corresponding control axis is within the specified allowance.
 These signals become "0" when:
 The servo error of the corresponding control axis exceeds the specified allowance.

Signal address

	#7	#6	#5	#4	#3	#2	#1	#0
F018					INP4	INP3	INP2	INP1

7.4 Error detect

General Generally, the CNC does not zero the feedrate at the interface of two block during cutting feed.

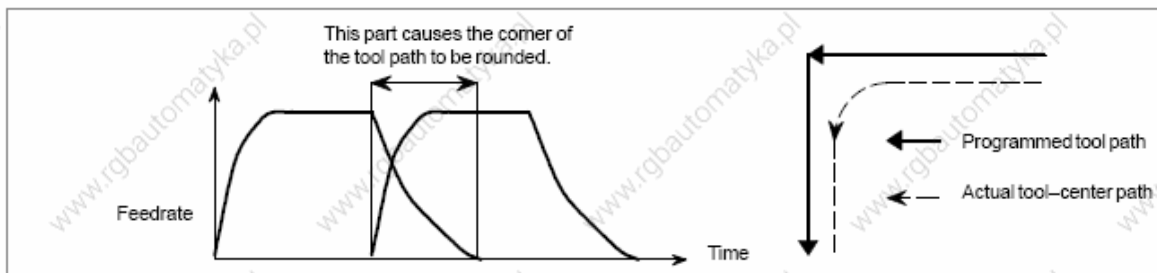

If the error detect signal is used, it is possible to specify that a block not be started until the acceleration/deceleration of the previous block has been completed.

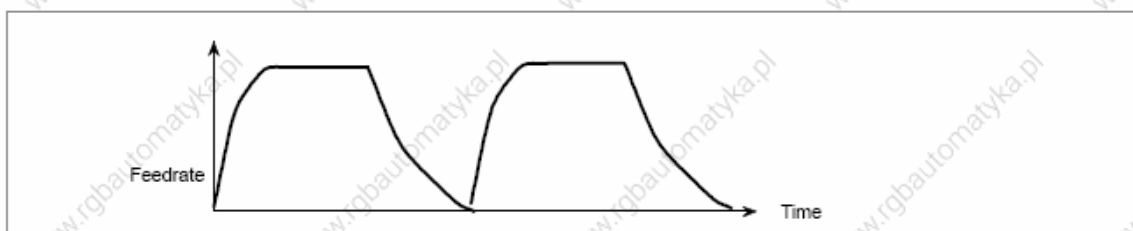

Signal Error detect signal

SMZ <G009#2>

[Classification] Input signal

[Function] If the signal is set to 1, the control unit operates as follows:

At the interface of two blocks during cutting feed, the control unit waits until the acceleration/deceleration of the first block has been completed. The setting of the SMZ signal determines whether, at the interface of two cutting blocks, the control unit waits until the acceleration/deceleration of the previous block has been completed.

Signal address

	#7	#6	#5	#4	#3	#2	#1	#0
F009					101	SMZ		

7.5 Override

7.5.1 Rapid traverse override

General F0, 25%, 50%, 100% can be used for the rapid traverse rate.

F0 is set by P093.

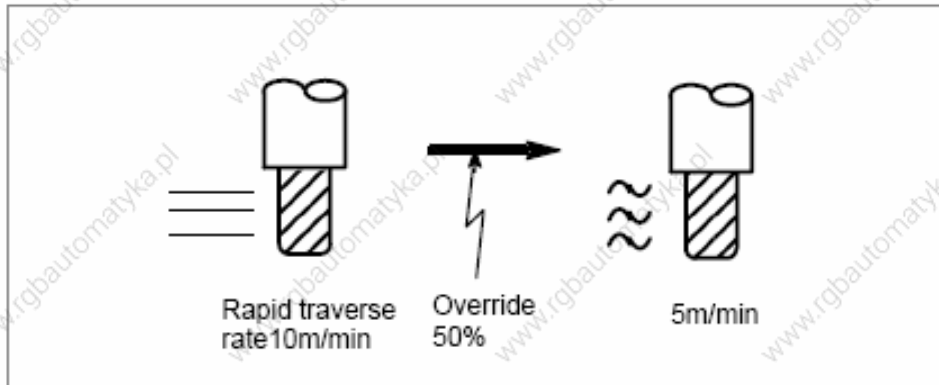

Feedrate Actual feedrate is obtained by multiplying the rapid traverse rate preset by parameter P088~092 by the override value determined by this signal, whether during automatic or manual operation(including manual reference point return).

F0 It is set by P093.

Signal Rapid traverse override signal

Rapid F0 (G025#0)

Rapid F25% (G025#1)

Rapid F50% (G025#2)

Rapid F100% (G025#3)

[Classification] Input signal

[Function] These signals are for rapid traverse rate override.

7.5.2 Feedrate override

General A programmed feedrate can be reduced or increased by a percentage selected by the override dial. This feature is used to check a program. For example, when a feedrate of 100 mm/min during is specified during the program, setting the override dial to 50% move the tool at 50 mm/min.

Signal Feedrate positive override signal (G24#0)

Feedrate negative override signal (G24#2)

[Classification] Input signal

[Function] Cutting feedrate override signal. 16 steps (0%~150%).

[Operation] Actual feedrate is obtained by multiplying the specified speed by the override value selected by this signal.

7.5.3 Override cancel

General The override cancel signal fixes the feedrate override to 100%.

Signal Override cancel signal

OVC (G024#1)

[Classification] Input signal

[Function] The feedrate override is fixed to 100%.

[Operation] When the signal is 1, CNC operates as follows:

- The feedrate override is fixed to 100% irrespective of the feedrate override signal.
- Rapid traverse override and spindle speed override are not affected.

Signal address

	#7	#6	#5	#4	#3	#2	#1	#0
G024							OVC	

8 Miscellaneous Function (M, S, T function)

8.1 Miscellaneous function

General * miscellaneous function (M code) When up to 8-bit numbers after the address M is specified, the code signal and strobe signal are transmitted to the machine which use these signals to start or cut off its relative functions.

Basic procedure

The following signals are used for the following functions.

Function	Program address	Output signal			Completion signal
		Code signal	Strobe signal	Distribution completion signal	
Miscellaneous function	M	M**	MF	DEN	FIN
Spindle function	S	S00~S31	TF		
Tool function	T	T00~T31	BF		

Each function uses different program addresses and different signals, but they all input and output signals during the same way, as described below. (A sample procedure for the miscellaneous function is described below. The procedures for the spindle speed function, tool function, and secondary miscellaneous function, are obtained simply by substituting S, T, or B during place of M).

- (1) Suppose that MXXX is specified during a program:
If XXX is not specified, CNC alarms.
- (2) After M00~M399 is transmitted to machine interface, the strobe signal MF is set to 1. The code signal is the binary representation of the programmed value XXX.
If a move, dwell, spindle speed, or other function is specified during the same block as the miscellaneous function, the execution of the other function is started when the code signal of the miscellaneous function is transmitted.
- (3) When the strobe signal is set to 1, the PLC reads the code signal and performs the corresponding operation.
- (4) To execute an operation after the completion of the move, dwell or other function specified during the block, wait until distribution end signal DEN is set to 1.
- (5) Upon completion of the operation, the PLC set completion signal FDURING to 1. The completion signal is used by the miscellaneous function, spindle speed function, tool function. If any of these functions are executed simultaneously, the completion signal must be set to 1 upon completion of all the function.
- (6) If the completion signal remains set to 1 for a long time, the CNC sets the strobe signals

to 0 and reports that the completion signal has been received.

- (7) When the strobe signal is 0, the FDURING signal is set to 0.
- (8) When the FDURING signal is 0, all code signals are set to 0 and all sequence operations of miscellaneous function is completed.
- (9) CNC executes the next block when other instruction has been completed during the same block.
 - 1. When the tool function is executed, the programmed tool number is transmitted S code, T code.
 - 2. When the spindle speed function, tool function is executed, the code signal is maintained until a new code for the corresponding function is specified.

Time sequence is as follows:

There is one miscellaneous function during a block.

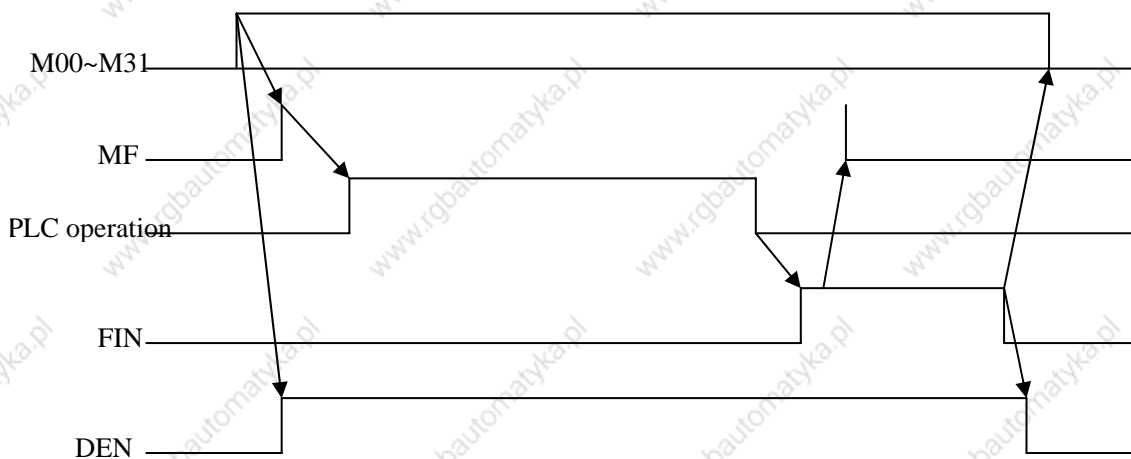

Move instruction and the miscellaneous function during the same block. Execution of a miscellaneous function without waiting for move instruction completion:

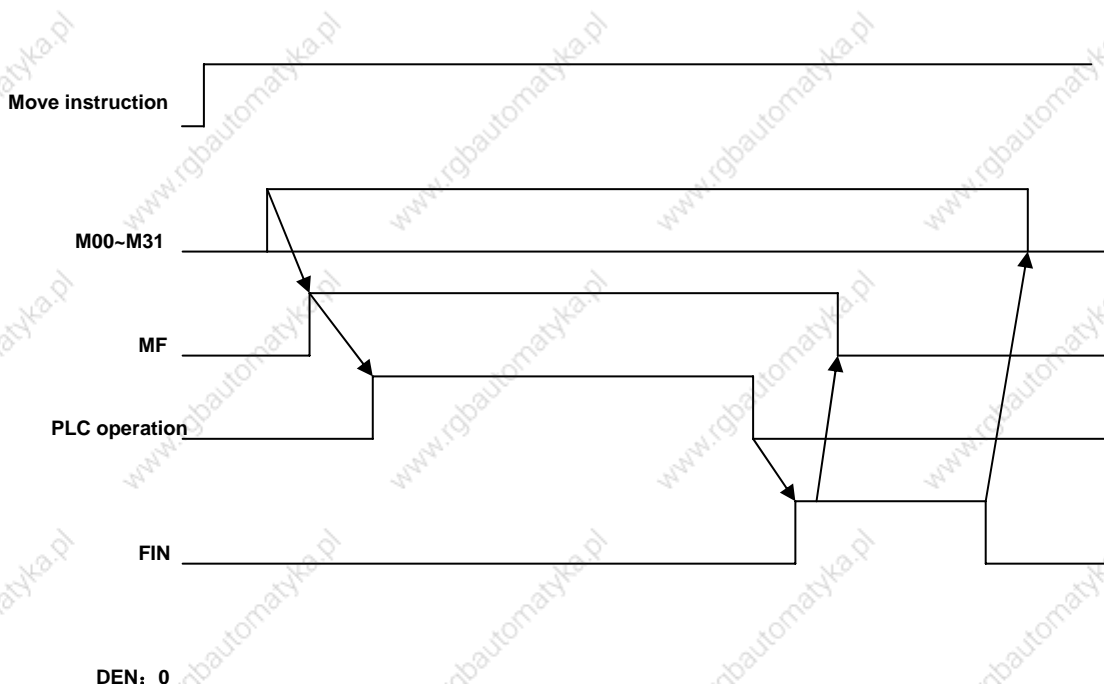

Move instruction and a miscellaneous function during the same block. Execution of a miscellaneous function after move instruction completion:

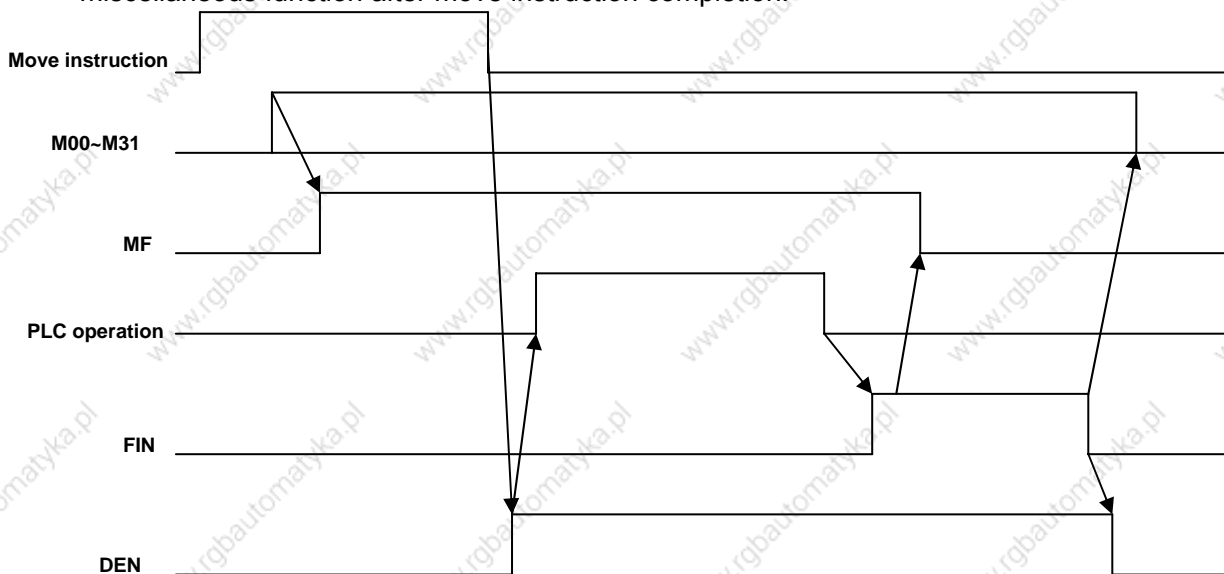

Signal Miscellaneous function code signal

M00~M99 (F030~F033)

Miscellaneous function strobe signal

MFEFD (F007#0)

[Classification] Output signal

[Function] These signals report PLC the specification of miscellaneous function.

[Output conditions] For relative output conditions and procedure, see Basic

Procedure .

Note:

1. The following miscellaneous functions are only processed during CNC: they are not output when programmed.

- * M98, M99, M198
- * M codes for calling subprograms
- * M codes for call during customer macro programs

2. Decode signals as well as the code signals and strobe signal are output for the miscellaneous function listed below.

M00, M01, M02, M30

3. M00~M39 with binary output to M code.

For example: M5 corresponds to 00000000, 00000000, 00000000, 00000101.

M decode signal

DM00 (F009#7)

DM01 (F009#6)

DM02 (F009#5)

DM30 (F009#4)

[Classification] Output signal

[Function] These signals report particular miscellaneous functions as specified.

The miscellaneous functions during an instruction program correspond to output signals as reported below.

Instruction	Output signal
M00	DM00
M01	DM01
M02	DM02
M30	DM30

[Output conditions] A decode M signal is 1 when:

- The corresponding miscellaneous function is specified, and any move instructions and dwell instructions specified during the same block are completed. These signals are not output when the end signal of the miscellaneous function is returned before completion of such move instructions and dwell instructions.

A decode M signal is 0 when:

- FDURING signal becomes 1.
- Reset.

Spindle speed code signal

S00~S31 (F022~F025)

Spindle speed strobe signal

TF (F007#2)

[Classification] Output signal

[Function] These signals report the spindle speed functions have been specified.

[Output conditions] For the output conditions and procedure, see Basic Procedure.

Output with S code of analog spindle.

Note: Binary S00~S31 outputs to S code.

For example, S4 corresponds to 00000000, 00000000, 00000000, 00000100.

Tool function code signal

T00~T31 (F026~F029)

Tool function strobe signal

BF (F007#3)

[Classification] Output signal

[Function] These signals report that tool function have been specified.

[Output conditions] For the output conditions and procedure, see Basic Procedure.

Note: Binary T00~T31 outputs to T code.

For example, T corresponds to 00000000, 00000000, 00000000, 00000011.

Miscellaneous function completion signal

FIN (G00#0)

[Classification] Input signal

[Function] The signal reports the completion of miscellaneous function, spindle speed function and tool function.

[Operation] When the signal becomes 1, for the control unit operation and procedure, see Basic Procedure.

Warning Only one end signal is used for all functions above. The end signal must go “1” after all function are completed.

Distribution end signal

DEN (F001#3)

[Classification] Output signal

[Function] The signal reports that all instructions are completed except those miscellaneous functions, spindle speed function, tool functions are contained during the same block and have been transmitted to PLC. They also report that the end signal from the PLC is being waited.

[Output conditions] DEN signal is 1 with the following conditions:

Waiting for the completion of miscellaneous functions, spindle speed functions, tool functions and all other instructions during the same block are completed.

DEN signal is 0 when:

The execution of one block is completed.

Signal address

	#7	#6	#5	#4	#3	#2	#1	#0
G000								FIN
F001					DEN			
F007					TF	SF		MF
F009	DM00	DM01	DM02	DM30				
F030	M07	M06	M05	M04	M03	M02	M01	M00
F031	M15	M14	M13	M12	M11	M10	M09	M08
F032	M23	M22	M21	M20	M19	M18	M17	M16

F033	M31	M30	M29	M28	M27	M26	M25	M24
F022	S07	S06	S05	S04	S03	S02	S01	S00
F023	S15	S14	S13	S12	S11	S10	S09	S08
F024	S23	S22	S21	S20	S19	S18	S17	S16
F025	S31	S30	S29	S28	S27	S26	S25	S24
F026	T07	T06	T05	T04	T03	T02	T01	T00
F027	T15	T14	T13	T12	T11	T10	T09	T08
F028	T23	T22	T21	T20	T19	T18	T17	T16
F029	T31	T30	T29	T28	T27	T26	T25	T24

8.2 Auxiliary function lock

General Inhibits execution of a specified M, S, and T function. That is, code signals and strobe signals are not issued. This function is used to check a program.

Signal Auxiliary function lock signal

AFL (G021 #3)

[Classification] Input signal

[Function] The signal selects the auxiliary function lock, i.e., the signal disables the execution of the specified M, S, T function.

[Operation] When the signal becomes 1, the control unit functions are as follows:

1. The control unit does not execute M, S, and T functions. That is, the control unit stops the output of code signals and strobe signals.
2. If this signal becomes "1" after code signal output, the output operation is executed during the ordinary manner until its completion(that is, until the FDURING signal is received, and the strobe signal becomes to "0".)
3. Among the miscellaneous function, M00,M01, M02 and M30 are executed even when this signal is "1". All code signals, strobe signals, decode signals are output during the ordinary manner.
4. Even when this signal is "1", M98 and M99 are executed during the

control unit without outputting their execution results are executed during the ordinary manner.

Warning Even when this signal is “1”, spindle analog output or spindle serial output is executed.

Auxiliary function lock check signal

MAFL (F004#4)

[Classification] Output signal

[Function] The signal reports the state of auxiliary function lock signal AFL.

[Output conditions] When the signal is 1, the auxiliary function lock signal AFL is 1.
When the signal is 0, the auxiliary function lock signal AFL is 0.

Signal address

	#7	#6	#5	#4	#3	#2	#1	#0
G021				AFL				
F004			MAFL					

8.3 High-speed M/S/T interface

General To accelerate M/S/T/B function execution, the high-speed M/S/T/B interface has simplified the transfer of the strobe and completion signals of the M/S/T/B function.

High-speed strobe signal and completion signal.

Take M function as example. The method of spindle speed function(S code), tool function (T code) and 2nd miscellaneous function (B code) are the same as M function.

Basic procedure:

- (1) Suppose that the following program is shown:
Mxx;
Myy;
- (2) In response to an M command, the CNC system sends out the code signals M00~M31.
The CNC system inverts the logical level of the strobe signal MF, that is, from “0” to “1”, or from “1” to “0”.
- (3) CNC oversets the strobe signal: when the logic level and the optional signal of miscellaneous function completion signal are the same one, CNC confirms PMC processing is ended. During general mode, when CNC has detected FDURING signal rise edge (“0” to “1”) and it receives the

completion signal FDURING down edge (“1” to “0”), the operation is ended. For the new mode, when CNC has detected the skip of one completion signal, it confirms the operation is ended. Besides, for the general mode, M/S/T/B function have one common completion signal(FIN), but for the new mode, they have different endsignal, the completion signal of M, S, T, B function are separately MFIN, SFIN, TFDURING and BFIN. High-speed interface is also used for many M instructions of one block, and the interface provides sole completion signal for every M code, separately calling MFIN, MFIN2 and MFIN3. The transmission time sequence of many M code signals during one block is the same that of one M code signal during one block. The high-speed interface is also used for external operation function. Besides, the exclusive external operation EFD and completion signal EFIN. The receiving and transmission of the signals are the same that of optional signal and completion signal of miscellaneous function.

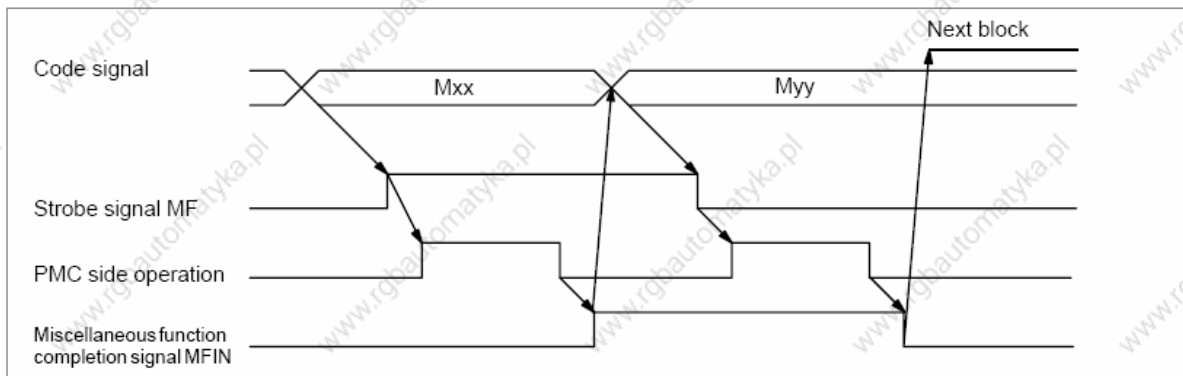

Signal 1st M function completion signal

MFIN1<G000#1>

[Classification] Input signal

[Function] Reports that the execution of a miscellaneous function using the high-speed M/S/T/B interface is completed.

[Operation] For the operation and procedure of the control unit, see Basic

Procedure..

Spindle function completion signal

SFIN<G000#4>

[Classification] Input signal

[Function] Reports that the execution of a spindle speed function using the high-speed M/S/T/B interface is completed.

[Operation] For the operation and procedure of the control unit, see Basic

Procedure.

Tool function completion signal

TFIN<G000#5>

[Classification] Input signal

[Function] Reports that the execution of a tool function using the high-speed M/S/T/B interface is completed.

[Operation] For the operation and procedure of the control unit, see Basic Procedure.

2nd, 3rd M completion signals

MFIN2, MFIN3

<G00#2, #3>

[Classification] Input signal

[Function] Report that the execution of 2nd/3rd M function using the high-speed M/S/T/B interface is completed.

[Operation] For the operation and procedure of the control unit, see Basic Procedure.

9 Spindle Speed Function

9.1 Spindle speed control mode

General For 218M system, the spindle is divided into gear spindle and analog spindle:

1. During gear spindle mode, CNC changes S code to switch value to output to the spindle to control the spindle speed.
2. During analog spindle, changes S code to analog value to output to the spindle to control the spindle speed. CNC

CNC transmits SIMSPL signal to report PLC the current CNC the mode of controlling spindle.

Spindle enable signal

ENB<F001#4>

The output signal related to the spindle control is the spindle enable signal ENB.

When non-zero instruction outputs to the spindle, ENB signal is logic 1; if the instruction is 0, ENB signal becomes 0.

When the analog spindle is used and the instruction to the spindle is 0 (analog voltage), the spindle motor will rotate with the low speed because there is the drift voltage for the spindle speed amplifier. And so, the ENB signal can be used to completely stop motor.

	#7	#6	#5	#4	#3	#2	#1	#0
F004				ENB				

9.1.1 Gear spindle

General Although the S instruction contains the spindle speed, the object that is actually controlled is the spindle motor. Therefore, the CNC must have some provision to detect the gear stage between the speed and spindle motor.

Signal Spindle speed code signal

S00~S31 (F022~F025)

Spindle speed strobe signal

TF (F007#2)

[Classification] Output signal

[Function] These signals report the actually specified the spindle speed function.

[Output conditions] For the output conditions and procedure, see **Basic Procedure**.

Use the S code of analog spindle to output.

Note: S00~S31 output to S code with the binary.

For example, S4 corresponds to 00000000, 00000000, 00000000 and 00000100.

9.1.2 Analog spindle

General The analog spindle is defined that the spindle speed is controlled by the analog voltage value from CNC. So, CNC changes S code into the analog voltage value to output to the spindle of machine tool to control the spindle speed.

1. The actual output analog voltage value equals to the S value controlled by the spindle multiplying the spindle override.
2. CNC still reports the speed by S00~S31 signal but SF signal does not output.

Signal Spindle positive override signal (**G22#5**)
 Spindle negative override signal (**G22#3**)
 Spindle override cancel signal OVC (**G22#4**)
 [Classification] Input signal
 [Function] The signal specifies the S override change controlled by spindle.

Note: The spindle override function is invalid as follows:

- Tapping cycle
- Thread cutting

Gear change process:

Although S instructions the spindle speed, the actual is to control the spindle motor. So, CNC needs to confirm the corresponding relation between the spindle motor and gear. Like S instruction selection, CNC selects the gear according to the previously defined gear speed range by parameter to report PMC to select the corresponding the gear by using the gear change select signal (GR3, GR2, GR1). At the same time, CNC outputs the spindle motor speed according to the selected gear. CNC outputs the instruction corresponded to the spindle (GR1, GR2, GR3 output) speed by specifying S0~S99999 during MDI mode. 2 or 3 speed gear (GR1, GR2, GR3) is set by No.246~248 to simultaneously output to the gear select signal. When the gear select signal is changed, CNC simultaneously output SF signal).

Specification of gear change signal is as follows:

	No. 2 gear	No. 3 gear	Remark
GR1	Low	Low	Low: low gear
GR2	High	Medium	Medium: middle gear
GR3		High	High: high gear

When the instruction voltage is 10V, the low gear spindle speed is A (parameter No.246) (min⁻¹) .

When the instruction voltage is 10V, the high gear spindle speed is B (parameter No.247) (min⁻¹ (middle gear during 3rd gear) .

When the instruction voltage is 10V, the high gear spindle speed is Ac (parameter No.248) (3rd gear) .

S and spindle motor speed instruction the voltage (0~10V) and gear select signal. (GR1, GR2, GR3) is as the above figure.

Signal: Gear select signal
GR1,GR2,GR3
<F034#0~#2>
[Classification] Output signal
[Function] These signals report PMC the selected gear.
[Output conditions] For the definition of these signals, see Gear change Mode.

Gear change select signal (input)
GR1,GR2,GR3<G002#0~#2>
[Classification] Input signal
[Function] These signals report CNC the current selected gear.
[Output conditions] For the definition of these signals, see Gear change Mode.

GEAR<G002#4>
[Classification] Input signal
[Function] These signals report CNC in-position of the current selected gear.
[Output conditions] For the definition of these signals, see Gear change Mode.

9.2 Spindle speed arrival signal

General The spindle speed arrival signal SAR is an input signal used as a condition for the CNC to start cutting feed. This signal is used generally when cutting feed should be started after the spindle reaches the specified speed. During this case, a sensor is used to check the spindle speed. The detected speed is sent to the CNC via the PLC. When the above operation is performed continuously using the PLC ladder, however, cutting feed may be started based on the SAR signal indicating the previous spindle state (spindle speed before change), if the spindle speed change instruction and the cutting feed instruction are issued at the same time.

Signal Spindle speed arrival signal
SAR (G003#0)
[Classification] Input signal
[Function] SAR signal controls the starting of cutting feed. i.e., when the signal is 0, CNC starts the cutting feed.
[Operation] Generally, the signal is used for reporting CNC the spindle arrives the specified speed. So, the signal is set to 1 after the spindle actual speed arrives the specified value.

CNC detects the SAR signal as follows:

1. CNC executes the check after the rapid traverse is switched into the

cutting feed and before 1st feed (traverse instruction) block is distributed and when the feed block is read and its time is set by the parameter No. 72.

2. After the S code is commanded and before the 1st feed block is distributed, CNC check wait time is the same that of the above.
3. When S code and the feed traverse during the same block are commanded, CNC detects SAR signal during the feed fixed time. When SAR signal is 1, the feed starts.

Signal address

	#7	#6	#5	#4	#3	#2	#1	#0
G003								SAR

9.3 Constant surface speed control

General With the spindle serial output or analog output function, specifying the surface speed (m/mduring or feet/mduring) directly during an S instruction makes it possible to change the spindle output continuously so as to maintaduring a constant surface speed at a programmed point. (For the rapid traverse instruction, however, the surface speed for the end point is output at the beginning of rapid traverse.)

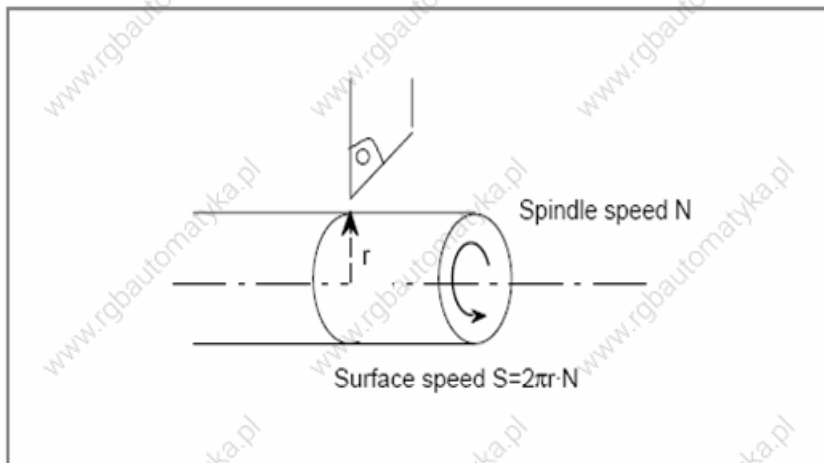

Whether or not constant surface speed control is performed is selected by G code.
 G96: execute the constant surface speed control, S is m/mduring or feet/mduring during G96.
 G97: do not execute the constant surface speed control, S is r/mduring during G97.

Signal constanst surface speed signal
CSS<F002#2>

[Classification] Output signal

[Function] The signal reports the constant surface speed control is executed.

[Output conditions] “1” reports the constant surface speed control (G96) is executed, and “0” reports it is not executed.

Signal address

	#7	#6	#5	#4	#3	#2	#1	#0
F002						CSS		

Parameter

	#7	#6	#5	#4	#3	#2	#1	#0
0061								SSC

[Data Classification] Bit

SSC defines whether the constant surface speed control is executed:

0: No

1: Yes

Note: When the parameter is changed, the power supply must be cut off before continuous operation.

9.4 Rigid tapping

General During a tapping cycle, synchronous control is applied to the tapping operation of a tapping axis and the operation of the spindle.

Namely, during rigid tapping (G74, G84), CNC needs to detect the rotation direction signal of spindle to confirm the cutting feed direction and machining process.

Procedure:

Spindle rotating→Z tool infeed tapping→transmit M05 to spindle→wait for spindle to completely stop→transmit CCW instruction→starting point of Z tool retraction→spindle stops rotating

So, to realize the rigid tapping, the corresponding ladder must be written to report the rotation direction of CNC external spindle.

Signal **rigid tapping signal**
RGTATP (G003#1)

[Classification] Output signal

[Function] Report to PLC that CNC is during the rigid tapping mode.

[Output conditions] RGTAP 1: the current CNC is during the rigid tapping mode.
0: the current CNC is not during the rigid tapping

mode.

Signal address

	#7	#6	#5	#4	#3	#2	#1	#0
G003							RGTAP	

Signal Spindle rotation direction

RGSPM, RGSP

(F012#1, #0)

(Classification) Output

(Function) Report to PMC that the spindle is CW/CCW during rigid tapping.

Spindle during rigid tapping:

RGSP: 1: clockwise rotation (CW) 0: non clockwise.

RGSPW: 1: counterclockwise (CCW) 0: non counterclockwise.

(Output conditions) During rigid tapping, these signals are output when the spindle is rotating, and they are not output as follows:

These signals are not output, for example, when the spindle is being positioned to a hole position, or a dwell operation is during progress at the bottom of a hole position, or a dwell operation is during progress at the bottom of a hole or at an R point. These signals are not output during the feed hold state or single block stop state. When the spindle is placed during the interlock stop state, machine lock state, or Z-axis ignore state, however, the spindle is not regarded as having stopped; these signals are output. These signals are valid only during rigid tapping mode. During normal spindle control, these signals are not output; both RGSP and RGSPM are set to "0".

Signal address

	#7	#6	#5	#4	#3	#2	#1	#0
G012							RGSPW	RGSP

10 Tool Function

10.1 T instruction executing tool change

During Auto and MDI mode, the T instruction is specified to execute the tool change. CNC interprets T instruction to transmit it to the specified tool selection number and strobe signal to wait for PLC to complete the tool change.

10.2 Tool life management

General When tools are classified into several groups, average tool life (No. of uses or time) is designated for each group. Whenever a tool is used, the usage time is subtracted from the tool life; when the tool life expires, the next tool during the group is selected. The tool sequence within a group is arranged during advance. The end of a tool's life is reported by tool change signal TLCH or individual tool change signal TLCHI. Tool change signal TLCH is set to 1 at the end of the life of the last tool of a group. Individual tool change signal TLCHI is set to 1 at the end of the life of the current tool.

Signal Tool change signal
TLCH<F064 # 0>
 [Classification] Output signal
 [Function] Report the end of the life of the last tool of a group.
 [Output conditions] The signal is set to 1 when:

- The life of the last tool of a group ends, after tool change has been performed each time the end of the life of each tool during a group is detected.

The signal is set to "0" when:

- Tool change reset is completed for all groups during which no available tools remain.

Note: The TLCH signal turns to "1" when the CNC is reset by M02 or M30, for instance after the tool life, based on the frequency of times used, is reached. When tool life is specified by usage time, TLCH turns to "1" when the tool life limit is reached. The signal will change during machine operation, but machining will continue until the end of the program.

Individual tool change signal

TLCHI<F064 # 2>
 [Classification] Output signal
 [Function] The signal reports the current tool life ends.
 [Output signal] The signal is set to "1" as follows:

- The current tool life end has been detected.

The signal is set to "0" as follows:

·after individual tool change reset signal is executed.

Tool change reset signal

TLRST<G007#2>

[Classification] Input signal

[Function] Clear all executable data including life count of the group, *, and @. To clear the data, specify a group number by tool group number select signal after replacing the worn-out tools that are displayed on the CRT. The data can also be cleared from the MDI.

[Operation] When the signal is set to 1, the control unit operates as follows:

- Clear all executable data including life count of the group. If the same group tool is specified after the machining is resumed, 1st tool during the group should be selected.

Note: When the automatic operation signal OP is “0”, the tool change reset signal TLRST is valid.

Individual tool change signal & reset signal

TLRST1<G007#1>

[Classification] Input signal

[Function] Individual tool change signal TLCHI is set to 0.

[Operation] When the signal is “1”, the control unit operates as follows:

- Individual tool change signal is set to “0”.

Note: 1. These signals are valid when the tool life management is performed on the basis of the tool life calculated during terms of time or cutting length.

2. Individual tool change signal TLCHI is not cleared by reset.

New tool select signal

TLNW<F064#1>

[Classification] Input signal

[Function] Report a new tool during some group is selected.

The signal can be used during some occasion. For example, a compensation value is to be measured automatically when a new tool is selected.

The new tool select signal is issued at the same time as TF(tool function strobe signal).

[Output conditions] The signal is “1” when:

- A new tool during some group is selected.

The signal is “0” when:

- The completion signal is “1”.

Tool group number select signal

TL01~TL128<G006#0~#7>

[Classification] Input signal

[Function] The tool group select signal must be used when TLRST or TLSKPP

signals are input.

TL01～1 28 the tool group number is given during advance.

[Operation] A specified tool group is selected.

Tool skip signal

TLSKP<G007#0>

[Classification] Input signal

[Function] A tool which has not reached its lifespan may be changed by one of two methods:

(i) Designate the group number for the tool by tool group number select signal then turn the tool skip signal.

When TLSKP turns to “1”, the next T-code instruction will pass over the current tool during the group for which the skip was designated, and select the next tool.

(ii) The group number is not specified, TLSPK signal becomes “1” and the machine skips to the next tool during the group currently during use.

Either of these methods is set using parameter. Tool life is counted from zero.

When the TLSPK signal is “1” and the last tool during the group is being used, the TLCH signal turns to “1”.

[Operation] When the signal is set to “1”, the control unit operates as follows:

- Selects the next tool during the group for which a skip is specified with the next T code.

- Suppose that the current tool during some group.

Caution: The cycle start lamp signal (STL) and feed hold lamp signal (SPL) must both be “0” before the TLSPK signal is input.

Tool life count value override signal

*TLV0～*TLV9<G007#3～#4, G008#0～#7>

[Classification] Input signal

[Function] If the parameter is set, the override is added to the life count (time).

When the signal is set to “0”, the override is valid. There is one override value for 10 binary codes.

The override of valid life count value is the total of valid override value. The override value is specified during the increment of 0.1 and its range is 0～99.9.

$$\text{Override value} = \sum_{i=0}^9 \{2^i \times V_i\}$$

- *TLV0 × 0.1
- *TLV1 × 0.2
- *TLV2 × 0.4
- *TLV3 × 0.8
- *TLV4 × 1.6
- *TLV5 × 3.2
- *TLV6 × 12.8
- *TLV7 × 25.6
- *TLV8 × 51.2
- *TLV9

(For example) When *TLV7, *TLV6 and TLV3 are set to 0, the override value is counted as follows: $12.8 + 6.4 + 0.8 = 20.0$, the life count value multiplies 20.0.

[Operation] The actual cutting time is counted and it multiplies the override value of these signals to get the time, which is taken as the basis of tool life management.

Signal address

	# 7	# 6	# 5	# 4	# 3	# 2	# 1	# 0
F064						TLCHI	TLNW	TLCH
G006	TL128	TL64	TL32	TL016	TL08	TL04	TL02	TL01
G007				*TLV1	*TLV0	TLRST	TLRST1	TLSKP
G008	*TLV9	*TLV8	*TLV7	*TLV6	*TLV5	*TLV4	*TLV3	*TLV2

11. Programmng Instruciton

11.1 Custom macro program

General Although subprograms are useful for repeating the same operation, the custom macro function also allows use of variables, arithmetic and logic operations, and conditional branches for easy development of general programs. A machining program can call a custom macro with a simple instruction, just like a subprogram.

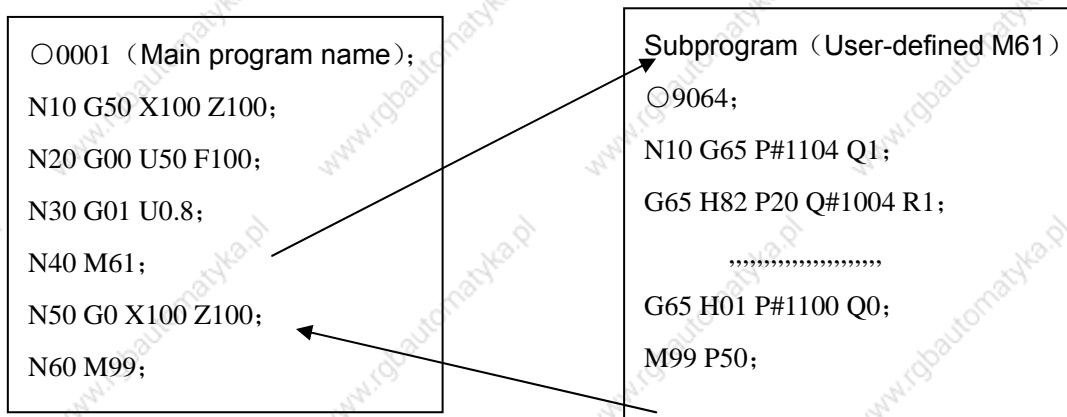

This reports some function programmed by macro program can be taken as the general function.

i.e., the program can be written by the data variable(variable data or unkown data. For example, the custom program can be used for technology.

Signal Custom macro program input signal

UI000~UI015 (G054, G055)

[Classification] Input signal

[Function] The signals do not provide any functions for the control unit. These signals which are taken as one of system variable is read by macro program, used for the interface signal between macro program and PLC.

The system variable corresponding to these signals are as follows:

Signal	Address	Variable
UI000	G54#0	#1000
UI001	G54#1	#1001
UI002	G54#2	#1002
UI003	G54#3	#1003
UI004	G54#4	#1004
UI005	G54#5	#1005

UI006	G54#6	#1006
UI007	G54#7	#1007
UI008	G55#0	#1008
UI009	G55#1	#1009
UI010	G55#2	#1010
UI011	G55#3	#1011
UI012	G55#4	#1012
UI013	G55#5	#1013
UI014	G55#6	#1014
UI015	G55#7	#1015
UI000~ UI015	G54, G55	#1032

Note: #1032 is variable with 16-bit as follows:

Signal address

	#7	#6	#5	#4	#3	#2	#1	#0
# 1032	UI007	UI006	UI005	UI004	UI003	UI002	UI001	UI000
# 1032	UI015	UI014	UI013	UI012	UI011	UI010	UI009	UI008

Custom macro program output signal

UO000~UO015

(F054~F055)

UO100~UO131

(F056~F059)

[Classification] Output signal

[Function] The signals do not provide any functions for the control unit. These signals which are taken as one of system variable are read/written by macro program, used for the interface signal between macro program and PLC.

The system variable corresponding to these signals are as follows:

Signal	Address	Variable
UO000	F54#0	#1100
UO001	F54#1	#1101
UO002	F54#2	#1102
UO003	F54#3	#1103
UO004	F54#4	#1104
UO005	F54#5	#1105
UO006	F54#6	#1106
UO007	F54#7	#1107
UO008	F55#0	#1108
UO009	F55#1	#1109
UO010	F55#2	#1110
UO011	F55#3	#1111
UO012	F55#4	#1112
UO013	F55#5	#1113
UO014	F55#6	#1114
UO015	F55#7	#1115
UO000~ UO015	F54, F55	#1132
UO100~ UO115	F56~F59	#1133

Note:

1132 is a variable with 16-bit.

1133 is a variable with 32-bit.

Composition is as follows:

	# 7	# 6	# 5	# 4	# 3	# 2	# 1	# 0
# 1132	UO007	UO006	UO005	UO004	UO003	UO002	UO001	UO000
# 1132	UO015	UO014	UO013	UO012	UO011	UO010	UO009	UO008
# 1133	UO107	UO106	UO105	UO104	UO103	UO102	UO101	UO100
# 1133	UO115	UO114	UO113	UO112	UO111	UO110	UO109	UO108
# 1133	UO123	UO122	UO121	UO120	UO119	UO118	UO117	UO116
# 1133	UO131	UO130	UO129	UO128	UO127	UO126	UO125	UO124

11.2 Canned cycle

General Canned cycles make it easier for the programmer to create programs. With a canned cycle, a frequently-used machining operation can be specified during a single block with a G function; without canned cycles, normally more than one block is required. During addition, the use of canned cycles can shorten the program to save memory. One canned cycle consists of a sequence of six operations:

- Operation 1: Positioning a hole
- Operation 2: Rapid traverse up to R level
- Operation 3: Hole machining
- Operation 4: Operation at the bottom of a hole
- Operation 5: Retraction to point R level
- Operation 6: Rapid traverse up to the initial point

Operation sequence of canned cycle is as follows:

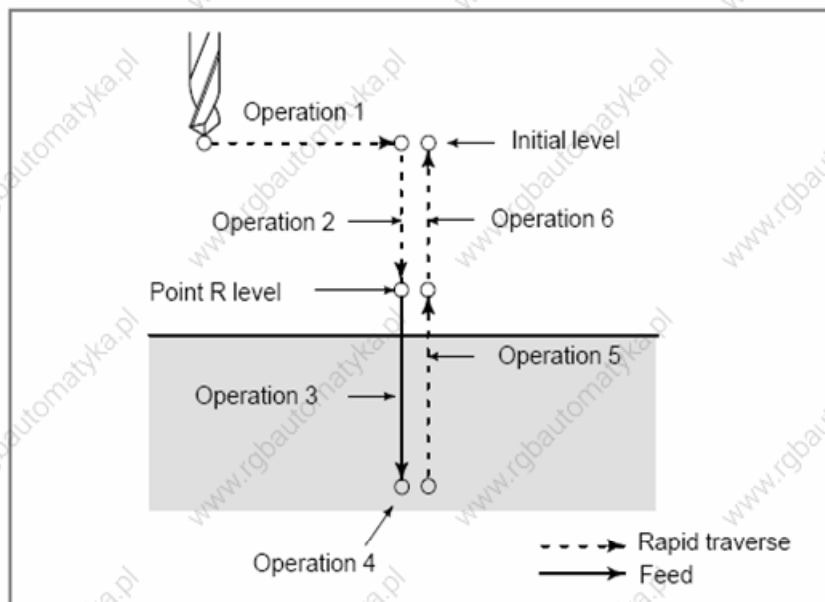

The following canned cycles require spindle control:

- | | |
|----------------------------|------------------------|
| Reverse tapping cycle G74) | Fine boring cycle G76) |
| Tapping cycle G84 | Boring cycle G86 |
| Back boring cycle G87 | Boring cycle G88 |

For spindle control, the following normal miscellaneous functions are used:

See the description of the miscellaneous functions.

- M03: CW spindle rotation
- M04: CCW spindle rotation
- M05: Spindle stop
- M19: Spindle orientation

When the rotation direction of the spindle is to be switched from one direction to the other (for example, when M04 is output during M03 operation), a parameter can be specified whether to send M05 at the time switching).

[Data Classification] **Bit**

INI Unit of input:

0: mm

1: inch

Note: When this parameter is set, the power must be turned off before operation is continued.

11.4 Small hole peck drilling cycle

General During peck drilling, the tool enters and retracts from hole based on an overload torque check signal (skip signal) until the designed hole depth is reached. The spindle speed and cutting feedrate are changed on each entry of the hole.

The cycle is realized by:

*X and Y axis positioning

*Positioning at point R along the Z axis

*Cutting along the Z axis (first time, depth of cut Q, incremental)

Signal small hole peck drilling signal

PECK2<F013#5>

[Classification] Output signal

[Function] The signal reports if the small hole peck drilling is executed.

[Output conditions] When this signal becomes “1”, the control unit operates as follows:

1. Retracts the tool from Z point to R point /initial level after the tool executes the hole positioning along the non drilling axis.
2. The signal is not 1 during the hole positioning.

Signal address:

	#7	#6	#5	#4	#3	#2	#1	#0
F013				PECK2				

12 Display/Set

12.1 Clock Function

General Time is displayed during the hour/nimute/secod format on set screen.
The custom macro system variable can be used to read the time.
Time reportation can be read and written.

12.2 Displaying operation history

General This function displays a history of the key stroke and signal operations, performed by the CNC operator, when a failure or CNC alarm occurs.

12.3 Help function

General The help function displays on the screen detailed reportation about alarms issued during the CNC and about CNC operations. The screen displays detailed information about the alarms and how to recover from them. The detailed information is displayed only for a limited number of P/S alarms. These alarms are often misunderstood and are rather difficult to understand.

12.4 Operation hour and parts count display

General This function displays the integrated power-on time, the integrated cycle operation time, the integrated cutting time and timer (started by an input signal from PMC) on the screen. The integrated cycle operation time, the integrated cutting time and timer can be altered and preset, During addition to the above, this function displays the count of the total number of parts machined, the number of parts required and the number of completed parts on the screen. Each time M02, M30 or a parameter set M code is executed, the count of the total number of parts machined and the number of parts compelted is incremented by 1. If the count of the number of parts machined reaches the number of parts required, a signal is output to the PMC side. It is possible for the operator to change and preset the number of parts required and the number of parts completed.

Signal Target part count reached signal
PRTSF <F061#1>
[Classification] Output signal
[Function] Reports to the PMC that the specified number of parts have been machined.
[Output conditions] The PRTSF signal is set to when :

- Machining of the specified number of parts has been completed.

When the required number parts are zero, this signal is not set.

The PRTSF signal is set to 0 when:

- Maching of the specified number of parts has not yet been completed.
- The system is reset.

General-purpose integrating counter start signal

TMRON <G009#0>

[Classification] **Input signal**

[Function] The CNC has a counter which is started by an input signal from the PMC. Additionally, there are counters for counting the automatic operation time and counting cutting time. The count for these counters can be displayed on the screen. The count can be preset by the operator pressing MDI key.

[Operation] When the signal is set to 1, the counter starts counting.

Signal address

	#7	#6	#5	#4	#3	#2	#1	#0
F061							PRTSF	
G009								TMRO

12.5 Memory protection key

General A key called the data protection key is used to prevent part programs, offset values, parameters, and setting data from being registered, modified, or deleted erroneously.

Signal **Memory protection signal**
KEY1 ~ KEY4<G005#0~#3>

[Classification] **Input signal**

[Function] Enables the changing of the memory contents from the MDI panel. Four signals are provided. The operations that can be performed on the contents of memory by each signal vary depending on the setting of parameter.

When KEY=0 KEY1: Enables the input of tool compensation values and the workpiece zero point offset values, and workpiece coordinate systems shift amount.

KEY2: Enables the input of setting data and macro variables and tool life management data.

KEY3: Enables program loading and editing.

KEY4: Enables PMC data(counter data tables)

When KEY=1 KEY1: Enables program loading and editing, as well as the input of PMC parameters.

KEY2 to KEY4: Not used.

[Operation] When a signal is set to 0, the associated operations are disabled.

When a signal is set to 1, the associated operations are enabled.

Signal address

	#7	#6	#5	#4	#3	#2	#1	#0
G005					KEY4	KEY3	KEY2	KEY1

13 Measurement

13.1 Skip function

General Linear interpolation can be commanded by specifying axial following the G31 instruction, like G01. If an external skip signal is input during the execution of this instruction, execution of the instruction is halted and the next block is executed. The skip function is used when the end of machining is not programmed but specified with a signal from the machine, for example, during grinding. It is used also for measuring the dimensions of a workpiece.

The coordinate values when the skip signal is turned on can be used during a custom macro because they are stored during the custom macro system variable #5061~#5068, as follows:

#5061 1st axis coordinate value
 #5062 2nd axis coordinate value
 #5063 3rd axis coordinate value
 :

Signal **Skip signal**
SKIP <X002#4>
SKIPP <G001#1>

[Classification] Input signal

[Function] This signal terminates skip cutting. That is, the position where a skip signal turns to “1” during a block containing G31 is stored during a custom macro variable, and the move instruction of the block is terminated at the same time.

[Operation] When a skip signal turns to “1”, the control unit works as described below.

- When a block contains a skip cutting instruction G31, the control unit reads and stores the current position of the specified axis at that time. The control unit stops the axis, then cancels the remaining distance that the block was supposed to be moved.
- The skip signal is monitored not for a rising edge, but for its state. So, if a skip signal continues to be “1”, a skip condition is assumed to be satisfied immediately when the next skip cutting is specified.

Note:

1. The skip signal width requires at least 10ms.
2. The CNC directly reads the skip signal SKIP <X002#4>; the PMC is no longer requires to process the signal.
3. If the skip function G31 is not used, the PMC can use the signal terminal SKIP <X002#4> corresponding to the skip signal as a general purpose input signal.

Signal address

	#7	#6	#5	#4	#3	#2	#1	#0
X002				SKIP ¹³²				

G001							SKIPP	
------	--	--	--	--	--	--	-------	--

13.2 Torque limit skip

General Sepcifying a move instruction after G31 P99 (or G31 P98) with a motor torque limit set (for example, specifying a torque limit on the PMC screen) allows the same cutting feed as that specified with G01 to be performed. While the tool is moved with a motor torque limit set during cutting feed, skip is performed when a signal indicating that the motor torque limit has been reached is input as a result of an operation such as pushing somethind against the motor.

Basic operations When the motor torque limit is reached or the SKIP signal <X002#4> is input during the execution of G31 P99, the execution of the next block starts without executing the remaining portion of the move instruction. When the motor torque limit is reached during the execution of G31 P98, the execution of the next block starts without executing the remaining portion of the move instruction. When no torque limit is specified before executing G31 P99 or P98, the move instruction is executed without performing the skip operation. For G31 P99 and P98, the coordinate, indicating the position to which the tool is to be positioned after skip, is stored during the system variable of the custom macro.

Signal Torque limit reached signals
TRQL1 to TRQL4 <F021>
 [Classification] Output signal
 [Function] Reports that the torque limit has been reached.
 [Output conditions] Set to "1" when :
 ·The torque limit has been reached for the corresponding axis.
 Set to "0" when:
 ·The torque limit has not been reached for the corresponding axis.
 Number 1 to 4 report the corresponding axis numbers.

Signal address

	#7	#6	#5	#4	#3	#2	#1	#0
F021					TRQL4	TRQL3	TRQL2	TRQL1

- Note:**
1. Specify a torque limit before G31 P99/P98. If G31 P99/P98 is executed with no torque limit specified, the move instruction is executed without a skip operation.
 2. When G31 P99 is specified, the SKIP signal causes a skip operation. However, avoid using the high-speed skip operation.
 3. Before specifying G31 P99/P98, cancel tool-tip radius compensation with G40.
 4. Set the SKF bit(bit 7 of parameter No.6200) to 0 to disable the dry run, override, and automatic acceleration/deceleration functions for the G31 skip instruction.

Appendix

Signal list (During order of address)

F signal

Address	Signal name	Symbol	Reference item
F000#4	Feed hold alarm signal	SPL	5.1
F000#5	Cycle start alarm signal	STL	5.1
F000#6	Servo ready completion signal	SA	2.2
F000#7	Automatic operation signal	OP	5.1
F001#0	Alarm signal	AL	2.4
F001#1	Resetting signal	RST	5.2
F001#3	Distribution completion signal	DEN	8.1
F001#4	Spindle enable signal	ENB	9.3
F001#5	Tapping signal	TAP	11.2
F001#6	Cancellign rigid tapping signal	D TAP	11.2
F002#0	Inch input signal	INCH	11.3
F002#1	Rapid traversing signal	RPDO	2.8
F002#2	Constant surface speed signal	CSS	9.3
F002#3	Thread cutting signal	THRD	6.4
F002#4	Program start signal	SRNMV	5.5
F002#6	Cuuting feed signal	CUT	2.8
F002#7	Dry run check signal	MDRN	5.3.2
F003#0	Incremental feed select check signal	MINC	2.7
F003#1	MPG feed select check signal	MH	2.7
F003#2	JOG feed select check signal	MJ	2.7
F003#3	Manual data input select check signal	MMDI	2.7
F003#4	DNC operation selection confirm signal	MRMT	2.7
F003#5	Automatic operation select check signal	MMEM	2.7
F003#6	Memory edit select check signal	MEDT	2.7
F003#7	Machine zero return select check signal	MZRO	2.7
F004#0	Skip optional block check signal	MBDT	5.4
F004#1	All-axis machine lock check signal	MMLK	5.3.1
F004#3	Single block check signal	MSBK	5.3.3

GSK 广州数控 GSK218M CNC System Connection and PLC Manual

F004#4	Auxiliary function lock signal	MAFL	8.2
F004#5	Manual reference point return check	MREF	4.1
F007#0	Miscellaneous function strobe signal	MFEFD	8.1
F007#2	Spindle speed function strob signal	TF	8.1
F007#3	Tool function strob signal	BF	8.1
F009#4	Decode M signal	DM30	8.1
F009#5		DM02	
F009#6		DM01	
F009#7		DM00	
F012#0 F012#1	Spindle rotation direction signal	RGSP RGSPM	9.4
F013#0	Advanced preview control mode signal	G08MD	7.2
F013#5	Small-diameter peck drilling during process signal	PECK2	11.4
F014#0 --- F014#1	Position switch signal	PSW01 --- PSW10	1.5
F015#0	Servo axis abnormal load detected signal	ABTQSV	2.10
F015#1	Spindle abnormal load detected signal	ABTSP	2.10
F016	Reference point return end signal	ZP1 --- ZP5	4.1
F017	Axis moving direction signal	MV1 --- MV5	1.1
F018	Arrival signal	INP1 --- INP5	7.3
F019	Axis moving direction signal	MVD1 --- MVD5	1.1
F020	Mirror image check signal	MMI1 --- MMI5	1.4
F021	Torque limit reached signal	TRQL1 --- TRQL4	13.2
F022 --- F025	Spindle speed code signal	S00 --- S31	9.1.1
S0(F022.0),S1(F022.1),S2 (F022.2),S3(F022.3),S4(F022.4),S5(F022.5),S6(F022.6),S7(F022.7)			
T00 --- T31	Tool function code signal	T00 --- T31	8.1
F030、31、62、63	Miscellaneous function code signal	M**	8.1
M03(F030.0),M04(F030.1),M05(F030.2), M08(F031.0),M09(F031.1),M10(F031.2),M11(F031.3),M32(F031.4),M33(F031.5),M00(F031.7)			
M16(F062.0) ,M17(F062.1) ,M19(F062.2) ,M21(F062.3) ,M22(F062.4) ,M23(F062.5), M24(F062.6) ,M44(F062.7) ,M45(F063.0) ,M50(F063.1) ,M51(F063.2) ,M53(F063.3)			
F034#0 --- #2	Gear select signal	GR1,GR2,GR3	9.1.2
F054,F055 F056 --- F059	Customer marco program output signal	U000 --- U015 U100 --- U131	11.1
F060	Referece point stablishment signal	ZRF1 ---- ZRF5	4.1
F061#1	Required parts reach signal	PRTSF	12.4

F064#0	Tool change signal	TLCH	10.3
F064#1	New tool select signal	TLNW	10.3
F064#2	Individual tool change signal	TLCHI	10.3

G signal

Address	Signal name	Symbol	Reference item
G000#0	Miscellaneous function completion signal	FIN	8.1
G000#1	1 st M function completion signal	MFIN1	8.1
G000#2	2 nd M function completion signal	MFIN2	8.1
G000#3	3 rd M function completion signal	MFIN3	8.1
G000#4	Spindle function completion signal	SFIN	8.1
G000#5	Tool function completion signal	TFIN	8.1
G001#0	Emergency stop signal	*ESP	2.1
G001#1	Skip signal	SKIPP	13.1
G001#2	Interlock signal	*IT	2.6
G001#3	Reset signal	RST	5.2
G002#0 --- #2	Gear select signal (input)	GR1,GR2, GR3	9.1.2
G002#4	Gear change completion signal	GEAR	9.1.2
G003#0	Spindel speed arrival signal	SAR	9.1.2
G003#1	Ridig tapping signal	RGTAP	9.4
G004#0 --- #4	MPG halt select signal	HS11A --- HS11D	3.3
G005#0 --- #3	Memory protection signal	KEY1 ---- KEY4	12.5
G006#0 ---- #7	Tool group number select signal	TL0 ---- TL128	10.3
G007#0	Tool skip signal	TLSKP	10.3
G007#1	Individual tool change signal	TLRST1	10.3
G007#2	Tool change reset signal	TLRST	10.3
G007#3 --- #4, G008#0 --- #7	Tool life count override signal	*TLV0 --- *TLV9	10.3
G009#0	General integrated counter start signal	TMR ON	12.4
G009#1	Customer marco program halt signal	UINT	11.1
G009#2	Error detect signal	SMZ	7.4
G009#3	Each-axis VRDY OFF alarm ignore signal	IGNVRY	2.9
G009#4	Machine ready completion signal	MRDY	2.5
G010#0 ---- #4	Mirror image signal	MT1 --- MT5	1.4
G011#0 ---- #4	Each-axis machine tool lock signal	MLK1 --- MLK5	5.3.1
G012#0 ---- #4	Overtravel signal	*+L1 --- *+L5	2.3
G013#0 ---- #4		*-L1 ---- *-L5	
G014#0 ---- #4	Servo off signal	SVF1 --- SVF5	1.3
G015#0 ---- #4	Each axis interlock signal	*IT1 ---- *IT5	2.6
G016#0	External reset signal	ERS	5.2
G017#0 ---- #4	Zero return deceleration signal check		4.1

Volume Three Operation

1 PLC Interface Display

1.1 Automatic operation when GSK218M PLC power on

When PMC includes the enabled sequence program, it starts immediately the automatic operation by the setting of the keep relay after power on. PMC screen are not needed to display every power-on to execute the sequence program.

Note: The keys during < > are the panel; the ones in **【 】** are the soft keys; **【 】** is the interface corresponding the current soft key; **◆** reports there is the sub-menu during the menu; all operations during PCL are executed during MDI mode and only view and search can be executed during other modes.

1.2 INFO interface display

1.2.1 INFO interface

Press <INFO> key on the panel to enter the default INFOR interface as Fig. 1-2-1. If the **【INFO】** soft key has not found on the below of the screen, the bit parameter No: N0: 26#6=1 can be defined to set the key on the PMC interface, and then <INFO> is pressed to enter INFO interface. There is the version number of GSK218M, modification data, PLC I/O interface definition state and so on on INFO interface.

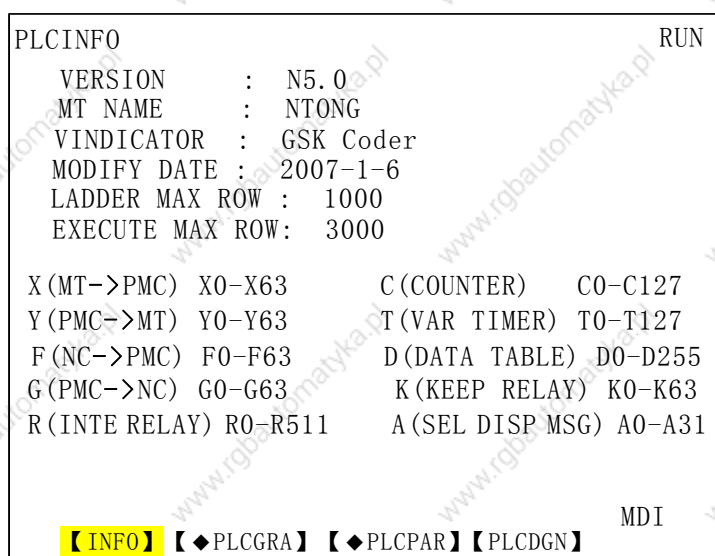

Fig. 1- 2- 1

4 soft keys on the below of the screw are 4 kind of information display interface of PMC.

1.2.2 PLCGRA interface

Press **【PLCGRA】** to enter **PLCGRA** interface or define the bit parameter N0: 26#6=1 to press **<INFO>** key on the PMC interface to enter **PLCGRA** interface as Fig.1-2-2.

PLCGRA	Ln: 000/429	RUN
X001.4		G001.0
X000.0		G012.0
X000.1		G012.1
X000.2		G012.2
X000.3		G012.3
X000.4		G013.0
X000.5		G013.1
X000.6		G013.2
X000.7		G013.3
X001.0	G020.0 G020.4 G020.5 G020.6	G017.0
DATA	MEA Emergency switch	MDI
【 INFO 】	【 ◆PLCGRA 】	【 ◆PLCPAR 】 【 PLCDGN 】

Fig. 1- 2- 2

Contents and operations on **PLCGRA** interface:

Line: current line position specified by the cursor during the ladder

RUN: operation state of ladder

Diagram: ladder program

Data/serial number: displaying input data. The serial number appears by pressing **<SEARCH>** on the panel to search the data. The CNC returns to the data displaying interface after press **<CANCEL>**.

MEA: Commentaries of element positioned by the cursor

MDI mode: current operation mode(note: the ladder can be modified only during MDI mode).

Press the Page Up/Page Down, four Direction keys to search, view and modify the elements.

1.2.3 PLCPAR interface

Press **【PLCGRA】** to enter **PLCPAR** interface or define the bit parameter N0: 26#6=1 to press **<INFO>** key on the PMC interface to enter **PLCPAR** interface as Fig.1-2-3.

PLCPara				RUN
NO.	ADDRESS	CURRENT	SET	
0000	C000	00000	00001	
0001	C001	00000	00001	
0002	C002	00000	00001	
0003	C003	00000	00001	
0004	C004	00000	00001	
0005	C005	00000	00001	
0006	C006	00000	00001	
0007	C007	00000	00001	
0008	C008	00000	00001	
0009	C009	00000	00001	
0010	C010	00000	00001	
0011	C011	00000	00001	

MDI

【INFO】 【◆PLCGRA】 【◆PLCPAR】 【PLCDGN】

Fig. 1- 2- 3

Contents and operations on **PLCPAR** interface:

- RUN: operation state of ladder
- NO: parameter serial number
- ADDRESS: parameter address
- CURRENT: current value of parameter
- SET: preset value of parameter

Data/serial number: displaying input data. The serial number appears by pressing <SEARCH> on the panel to search the data. The CNC returns to the data displaying interface after press <CANCEL>.

MDI mode: current operation mode(note: the relative parameter of PLCPAR can be modified only during MDI mode).

Press the Page Up/Page Down, four Direction keys to seach, view and modify the elements.

1.2.4 PLCGND interface

Press **【PLCGDN】** to enter PLCGND interface or define the bit parameter NO: 26#6=1 to press <INFO> key on the PMC interface to enter PLCGDN interface as Fig.1-2-4.

PLCDGN	RUN							
ADDR	N. 7	N. 6	N. 5	N. 4	N. 3	N. 2	N. 1	N. 0
F000	0	1	0	0	0	0	0	0
F001	0	0	0	0	1	0	0	0
F002	0	0	0	0	0	0	0	0
F003	0	0	0	0	0	0	0	0
F004	0	0	0	0	0	0	0	0
F005	0	0	0	0	0	0	0	0
F006	0	0	0	0	0	0	0	0
F007	0	0	0	0	0	0	0	0
F008	0	0	0	0	0	0	0	0
F009	0	0	0	0	0	0	0	0
F010	0	0	0	0	0	0	0	0
F011	0	0	0	0	0	0	0	0
序号								
								MDI
	【INFO】	【◆PLCGRA】	【◆PLCPAR】	【PLCDGN】				

Fig. 1- 2- 4

Contents and operations on **PLCGDN** interface:

RUN: operation state of ladder

ADDR: : address of diagnosis number

N.0~N.7 : bit number state of diagnosis address. 1: the signal is connected; 0: the signal is not connected.

CURRENT: current value of parameter

SET: preset value of parameter

Data/serial number: displaying input data. The serial number appears by pressing **<SEARCH>** on the panel to search the data. The CNC returns to the data displaying interface after press **<CANCEL>**.

MDI mode: current operation mode.

Press the Page Up/Page Down, four Direction keys to search the corresponding diagnosis number.

2 PLC Programming Operation

2.1 General

GSK218M CNC PLC operations are performed during the corresponding interfaces.

There are maduring two interfaces:

1. PLCGRA interface include: basic instruction, function instruction and instruction list.

Press **【PLCGRA】** to enter PLCGRA interface as Fig. 1-2-2. Press agaduring **【PLCGRA】** to enter PLCGRA interface as Fig. 2-2-1.

PLCGRA	Ln: 000/429	RUN
X001.4		G001.0
X000.0		G012.0
X000.1		G012.1
X000.2		G012.2
X000.3		G012.3
X000.4		G013.0
X000.5		G013.1
X000.6		G013.2
X000.7		G013.3
X001.0 G020.0 G020.4 G020.5 G020.6		G017.0
DATA	MEA Emergency switch	MDI
【◆B. INST】【F. INST】【◆REPERT】【◆EDIT】【RETURN】		

Fig. 2- 1- 1

2. **PLCRAR** interface includes CTR, TMR, DATA, KPAR. **PLCRAR** interface includes: CTR, TMR, DATA, KPAR.

Press **【PLCRAR】** to enter PLCRAR interface as Fig. 1-2-3. Press agaduring **【PLCRAR】** to enter PLCRAR interface as Fig. 2-2-2.

PLCPara				RUN
NO.	ADDRESS	CURRENT	SET	
0000	C000	00000	00001	
0001	C001	00000	00001	
0002	C002	00000	00001	
0003	C003	00000	00001	
0004	C004	00000	00001	
0005	C005	00000	00001	
0006	C006	00000	00001	
0007	C007	00000	00001	
0008	C008	00000	00001	
0009	C009	00000	00001	
0010	C010	00000	00001	
0011	C011	00000	00001	

MDI

【CTR】
【TMR】
【DATA】
【KPAR】
【RETURN】

Fig. 2-1-2

2.2 Basic instruction(B. INST)

Press **【B. INST】** during Fig. 2-1-2 to enter the basic instruction operation interface as Fig.2-2-1.

PLCGRA	Ln: 000/429	RUN
X001.4		G001.0
X000.0		G012.0
X000.1		G012.1
X000.2		G012.2
X000.3		G012.3
X000.4		G013.0
X000.5		G013.1
X000.6		G013.2
X000.7		G013.3
X001.0 G020.0 G020.4 G020.5 G020.6		G017.0
DATA	MEA:Emergency switch	

MDI

【┌┐】
【└┘】
【-()】
【→()】
【RETURN】
【▶】

Fig. 2-2-1

Press **【▶】** to display other basic instructions as Fig. 2-2-2.

PLCGRA		Ln: 000/429	RUN
X001.4			G001.0
X000.0			G012.0
X000.1			G012.1
X000.2			G012.2
X000.3			G012.3
X000.4			G013.0
X000.5			G013.1
X000.6			G013.2
X000.7			G013.3
X001.0		G020.0 G020.4 G020.5 G020.6	G017.0
DATA		MEA: Emergency switch	
			MDI

Fig. 2-2-2

The basic instructions are divided into 7 kind of graphic display:

- 【 】 : normally open contact
- 【 】 : normally close contact
- 【 () 】 : output coil
- 【 () 】 : output coil reverse
- 【 】 : horizontal conductive line
- 【 】 : vertical conductive line
- 【 】 : deleting vertical conductive line

Auxiliary soft key:

- 【 】 : Page Down
- 【 】 : Page Up
- 【 Esc 】 : return to the up menu.

2.3 Operations of ladder

Add element: position the cursor to the required, press the corresponding menu to input the element name, press <ENTER> to confirm the addition after it is displayed behind the data. If the current position has element, the new element will replace

the previous one.

Insert element: position the cursor to the required, press **<INSERT>** to insert empty position, and then add the new element as the above method. The cursor can insert orderly. (Note: ensure the indicator above **<CTRL>** key is OFF when inserting element.)

Delete element: press **<DELETE>** to delete the current element and the following one will orderly move forward (Note: ensure the indicator above **<CTRL>** key is OFF when deleting element.)

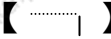
Add vertical conductive line: press  to add one vertical conductive line under the lower-right of current cursor position.

Delete vertical conductive line: press  to delete one vertical conductive line under the lower-right of current cursor position.

Add horizontal conductive line: press  to add one horizontal conductive line before the cursor position, if the current position has element, the horizontal conductive line replace the element.

Insert line: position the cursor to the any line of target line, press **<CTRL>**, and then press **<INSERT>** after the indicator above **<CTRL>** is ON, insert the blank line at the place above of the specified line by cursor, and the sequent line will orderly move down one line.

Delete line: position the cursor to the target line, press **<CTRL>**, and then press **<DELETE>** to delete the current line after the indicator above **<CTRL>** is ON, and the sequent line will orderly move up one line.

Delete block: position the cursor to the initial position which will be deleted, press **<L>** and input the address number of target block's coil, and last press **<ALT>**.

Copy block: position the cursor to the block head (first contact of left busbar) which will be copied, press **<M>** and input the block end (address number of coil of right busbar), and last press **<ALT>**.

Copy block: position the cursor to the block head (first contact of left busbar) which will be copied, press **<T>** and input the block end (address number of coil of right busbar), and last press **<ALT>**.

Paste block: position the cursor to the any line of target line, press **<F>**, and then press **<ALT>**.

Search: directly input the required element name, press 【 ↑ 】 to search up and press 【 ↓ 】 to search down after the data on screen is displayed,

Save: press <STORE> to save the modified ladder.

Ladder programming example:

1. position the cursor to the initial position of programming, press 【 —| 】 and there is normally-open contact symbol at the cursor position, directly input the element name X1.4 and press <ENTER> and X001.4 appears at the current cursor position.
2. right move the cursor, press 【 -|/ 】 , and there is there is normally-open contact symbol at the cursor position, directly input the element name X2.1 and press <ENTER> and X002.1 appears at the current cursor position.
3. position the cursor to the initial position of next line, press 【 -|/ 】 , there is there is normally-open contact symbol at the cursor position, directly input the element name X2.4 and press <ENTER> and X002.4 appears at the current cursor position.
4. right move the cursor, press 【 —| 】 , and draw a horizontal conductive line at the current cursor position.
5. up move the cursor, press 【 —|/ 】 , and draw a vertical conductive at the current cursor position.
6. press 【 —() 】 and the system automatic create the ouput coil, namely the necessary horizontal conductive line. Directly input the element name G1.0, press <ENTER> and G001.0 appears at the current cursor position.

The programmed ladder is as Fig. 2-3-1:



Fig. 2-3-1 Ladder example

Note: The green element in the ladder is turned on no matter that it is normally-open and normally-closed or outputs the coil, and the white indicates it is turned off (owing to the printing, the dark stands it is turned off, and the light stands it is turned on.)

2.4 Function instruction

Press 【 B. INST 】 during Fig. 2-1-1 to enter the basic instruction operation interface as Fig. 2-4-1.

PLCGRA		Ln: 000/429	RUN
X001.4			G001.0
X000.0			G012.0
X000.1			G012.1
X000.2			G012.2
X000.3		CTR TMR ROT COMP MOVN	G012.3
X000.4		DSCH COIN CALL SP SPE	G013.0
X000.5		END1 END2 ADD SUB XMOV	G013.1
X000.6		DEC COD DIFU DIFD EOR	G013.2
X000.7		ANDF ORF NOT JMPB LBL	G013.3
X001.0		RST SET SFT COM COME	G017.0
X001.0		G020.0 G020.4 G020.5 G020.6	G017.0
DATA		MEA:Emergency switch	
		MDI	
		【◆B. INST】【F. INST】【◆REPERT】【◆EDIT】【RETURN】	

Fig. 2-4-1

There are 30 PLC function instructions during the function instruction list. For the format and use of function instruction, see Programming.

2.5 Instruction list

Press **【INSTRUCTION LIST】** during PLCGRA interface as Fig.2-1-1 to enter the operation interface of instruction classification as Fig. 2-5-1.

PLCREPER		Step: 0000/1263	RUN
N0.	REPER		
0000	RD	X001.4	
0001	WRT	G001.0	
0002	RD	X000.0	
0003	WRT	G012.0	
0004	RD	X000.2	
0005	WRT	G012.1	
0006	RD	X000.4	
0007	WRT	G012.2	
0008	RD	X000.6	
0009	WRT	G012.3	
0010	RD	X000.1	
0011	WRT	G013.0	
DATA			MDI
【CONVERT】		【DOWN】	【STOP】
			【RETURN】

Fig. 2-5-1

Contents and operations of instruction list interface:

Step: the step number and total step number of current ladder run

RUN: operation state of ladder

Data/serial number: displaying input data. The serial number appears by pressing **<SEARCH>** on the panel to search the data. The CNC returns to the data displaying interface after press **<CANCEL>**.

MDI mode: current operation mode.

【CHANGE】: ladder is changed into instruction list.

【DOWNLOAD】: the instruction list is downloaded to CNC to automatically operation the PLC ladder.

【STOP】: stop ladder running.

【Esc】: return to the up menu.

Press the Page Up/Page Down, four Direction keys to search and position, view the instruction list address.

2.6 Edit instruction

PLCGRA	Ln: 000/429	RUN
X001.4		G001.0
X000.0		G012.0
X000.1		G012.1
X000.2		G012.2
X000.3		G012.3
X000.4		G013.0
X000.5		G013.1
X000.6		G013.2
X000.7		G013.3
X001.0	G020.0 G020.4 G020.5 G020.6	G017.0
DATA	MEA Emergency switch	MDI
【COPY】 【PASTE】 【DEL】 【REPLASE】 【RETURN】		

Contents and operations on instruction list interface:

LINE: displaying the current position of cursor and total line number of ladder

RUN: operation state of ladder

Data/serial number: displaying input data. The serial number appears by pressing **<SEARCH>** on the panel to search the data. The CNC returns to the data displaying interface after press **<CANCEL>**.

MDI mode: current operation mode.

【COPY】 : after inputting G12.1, press it and the ladder between the cursor and G12.1 can be copied.

【PASTE】 : paste the copied ladder.

【DELETE】 : after inputting G12.1, press it and the ladder between the cursor and G12.1 can be deleted.

【CHANGE】 : input the signal address needed to change, and press the key, the system prompts if the address is changed or all addresses are changed.

Y: YES; N: NOT; A: ALL

Press the Page Up/Page Down, four Direction keys to search and position, view the instruction list address.

2.7 PLC operation step

PLC operation step:

1. During PLCPAR interface, press **【KPAR】** to enter the viewing and setting interface of keep relay, operate PLC by modifying the related bit of K000, K001. (setting K000.0 to 1 can modify the ladder after saving). For the definition of related bit, see Function, Appendix A.1.
2. During PLCGRA interface, operate PCL to complete PLC programming. Press **<SAVE>**, the data field prompts “**SAVE SUCCEEDED!**”. The corresponding PMC alarms during saving when PLC is mistaken, please check PLC program.
3. During PLCGRA interface, press **<CHANGE>**, the data field prompts “CHANGING.....”, and “CHANGE SUCCEEDED!”. The ladder is changed into instruction list to download to CNC to automatically operation the system.

3 PLC Address, Parameter Setting

During PLC, the addresses and parameters of counter, timer, data list, keep relay are used, viewing and setting must be during the corresponding interface. During PLCPAR interface, press **【PLCPAR】** to enter PLC address, parameter setting interface as Fig. 3-1, including counter, timer, data list, keep relay and so on, used for viewing and setting the addresses, parameter and data list.

PLCPara				RUN
NO.	ADDRESS	CURRENT	SET	
0000	C000	00000	00001	
0001	C001	00000	00001	
0002	C002	00000	00001	
0003	C003	00000	00001	
0004	C004	00000	00001	
0005	C005	00000	00001	
0006	C006	00000	00001	
0007	C007	00000	00001	
0008	C008	00000	00001	
0009	C009	00000	00001	
0010	C010	00000	00001	
0011	C011	00000	00001	

MDI

Fig. 3-1

3.1 Counter

Press **【CTR】** during Fig. 3-1 to enter the view and the setting interface of counter as Fig. 3-1-1.

PLCPara				RUN
NO.	ADDRESS	CURRENT	SET	
0000	C000	00000	00001	
0001	C001	00000	00001	
0002	C002	00000	00001	
0003	C003	00000	00001	
0004	C004	00000	00001	
0005	C005	00000	00001	
0006	C006	00000	00001	
0007	C007	00000	00001	
0008	C008	00000	00001	
0009	C009	00000	00001	
0010	C010	00000	00001	
0011	C011	00000	00001	

MDI

Fig. 3- 1- 1

Contents and operations on counter interface:

OPERATION : operation state of ladder.

N0. : counter number, cannot be changed.

ADDRESS : counter address, cannot be changed.

CURRENT : counter current value, cannot be changed.

SET : counter preset value, can be changed during MDI mode.

Data/serial number: displaying input data. The serial number appears by pressing <SEARCH> on the panel to search the data. The CNC returns to the data displaying interface after press <CANCEL>.

MDI mode: current operation mode.

【Esc】 : return to the up menu.

Press <CHANGE> to download the setting value to operation the CNC. When the change is completed, the system displays: CTR Downloaded OK ! , when the change is not completed, the system displays: Can't download !

(Note: press 【CHANGE】 after modification to save the modification and operation the CNC.

Press the Page Up/Page Down, four Direction keys to search and position, view or modify the counter address.

3.2 Timer

Press 【TMR】 during Fig. 3-1 to enter the view and the setting interface of counter as Fig. 3-2-1.

PLCPara				RUN
N0.	ADDRESS	CURRENT	SET	
0000	T000	00000	00100	
0001	T001	00000	00100	
0002	T002	00000	00100	
0003	T003	00000	00100	
0004	T004	00000	00100	
0005	T005	00000	00100	
0006	T006	00000	00100	
0007	T007	00000	00100	
0008	T008	00000	00100	
0009	T009	00000	00100	
0010	T010	00000	00100	
0011	T011	00000	00100	

MDI

【CTR】 【TMR】 【DATA】 【KPAR】 【RETURN】

Fig. 3- 2- 1

Contents and operations on counter interface:

OPERATION : operation state of ladder.

N0. : counter number, cannot be changed.

ADDRESS : counter address, cannot be changed.

CURRENT : counter current value, cannot be changed.

SET : counter preset value, can be changed during MDI mode.

Data/serial number: displaying input data. The serial number appears by pressing **<SEARCH>** on the panel to search the data. The CNC returns to the data displaying interface after press **<CANCEL>**.

MDI mode: current operation mode.

【Esc】 : return to the up menu.

Press **<CHANGE>** to download the setting value to operation the CNC. When the change is completed, the system displays: CTR Downloaded OK ! , when the change is not completed, the system displays: Can't download !

(Note: press **【CHANGE】** after modification to save the modification and operation the CNC.

Press the Page Up/Page Down, four Direction keys to search and position, view or modify the counter address.

3.3 Data list

Press **【DATA】** during Fig. 3-1 to enter the view and the setting interface of counter as Fig. 3-3-1.

PLCPara			RUN		
N0.	ADDRESS	DATA	N0.	ADDRESS	DATA
000	D000	00000	012	D012	00000
001	D001	00000	013	D013	00000
002	D002	00000	014	D014	00000
003	D003	00000	015	D015	00000
004	D004	00000	016	D016	00000
005	D005	00000	017	D017	00000
006	D006	00000	018	D018	00000
007	D007	00000	019	D019	00000
008	D008	00000	020	D020	00000
009	D009	00000	021	D021	00000
010	D010	00000	022	D022	00000
011	D011	00000	023	D023	00000

MDI

【CTR】 【TMR】 【DATA】 【KPAR】 【返回】

Fig. 3-3-1

Contents and operations on data list interface:

OPERATION : operation state of ladder.

N0. : data list number, cannot be changed.

ADDRESS : data list address, cannot be changed.

DATA : data list setting value, can be changed during MDI mode.

Data/serial number: displaying input data. The serial number appears by pressing **<SEARCH>** on the panel to search the data. The CNC returns to the data displaying interface after press **<CANCEL>**.

MDI mode: current operation mode.

【Esc】 : return to the up menu.

Press **<CHANGE>** to download the setting value to operation the CNC. When the change is completed, the system displays: CTR Downloaded OK ! , when the change is not completed, the system displays: Can't download !

(Note: press **【CHANGE】** after modification to save the modification and operation the CNC.

Press the Page Up/Page Down, four Direction keys to search and position, view or modify the data list address.

3.4 Keep relay

Press **【KPAR】** during Fig. 3-1 to enter the view and the setting interface of counter as Fig. 3-4-1.

PLCPara	N.7	N.6	N.5	N.4	N.3	N.2	N.1	N.0	RUN
K000	0	0	0	0	0	1	0	1	
K001	0	0	0	0	1	0	0	1	
K002	0	0	0	0	0	0	0	0	
K003	0	0	0	0	0	0	0	0	
K004	0	0	0	0	0	0	0	0	
K005	0	0	0	0	0	0	0	0	
K006	0	0	0	0	0	0	0	0	
K007	0	0	0	0	0	0	0	0	
K008	0	0	0	0	0	0	0	0	
K009	0	0	0	0	0	0	0	0	
K010	0	0	0	0	0	0	0	0	
K011	0	0	0	0	0	0	0	0	
DATA									MDI
	【CTR】	【TMR】	【DATA】	【KPAR】	【RETURN】				

Fig. 3- 4- 1

Contents and operations on keep relay interface: :

RNU: operation state of ladder.

ADDR: keep relay address.

N.0~N.7 : bit number state of keep relay address. 1: After the CNC is turned off, the address keeps the state which is before power-off. 0: after the CNC is turned off, the address resets to the default state.

Data/serial number: displaying input data. The serial number appears by pressing **<SEARCH>** on the panel to search the data. The CNC returns to the data displaying interface after press **<CANCEL>**.

MDI mode: current operation mode.

【Esc】 : return to the up menu.

Press **<CHANGE>** to download the setting value to operation the CNC. When the change is completed, the system displays: KPAR Downloaded OK ! , when the change is not completed, the system displays: Can't download !

(Note: press **【CHANGE】** after modification to save the modification and operation the CNC.

K000~~K005 is taken up by the CNC. For its definition, see Function, Appendix A.1

Press the Page Up/Page Down, four Direction keys to search and position, view or modify the data list address.

3.5 F address corresponded to M function

In Fig.3-1, press **【▶】** to enter the next page, press **【MDEC】** to enter the search and setting interface of F address corresponded to M function as Fig. 3-5-1:

MCodeDEC (M00-M97~F026-F033)			RUN
MCODE	MEANING	ADDR	
M00	Program Stop	F031.7	
M01	Optional Stop	F030.4	
M02	End of Program	F030.5	
M03	Spindle forward	F030.0	
M04	Spindle backward	F030.1	
M05	Spindle stop	F030.2	
M06	Auto change tool	F030.3	
M07	STNANDBY	F***.*	
M08	Coolant on	F031.0	
M09	Coolant off	F031.1	
M10	A axis Clamp	F031.2	
M11	A axis Release	F031.3	
			MDI
【◀】	【MDEC】		【RETURN】

Fig. 3-5- 1

Content and operation of F address corresponded to M function:

MCodeDEC: MDEC interface.

M00-M97: setting range of M function command.

F026-F033: setting range of F address.

RUN: run status of ladder.

MCODE: M function number.

MEANING: M function explanation.

ADDR: F address can be modified in MDI mode by inputting one which is higher than the terminal user password, and the modified is valid after the system restarts.

MDI mode: current operation mode.

【Esc】: escape from the upper menu.

【◀】: enter the upper menu.

After modification, the system “Alarm”, prompting “Power OFF”, and the setting is value after the system restarts. In PLC program, there is M function setting, and after the address is modified, the corresponding ladder should be modified to avoid the unexpected operation of machine tool.

Search or modify F address corresponded to M by PageUp/PageDown and four direction keys on the operator panel.

Volume Four Connection

1 System Structure and Installation

1.1 System composition

GSK218M CNC system mainly consists of the following units as Fig. 1.1.

- (1) GSK218M CNC system
- (2) Additional operator panel(optional)
- (3) Stepper driver(number AC servo driver)
- (4) Stepper motor(servo motor)
- (5) AC transformer

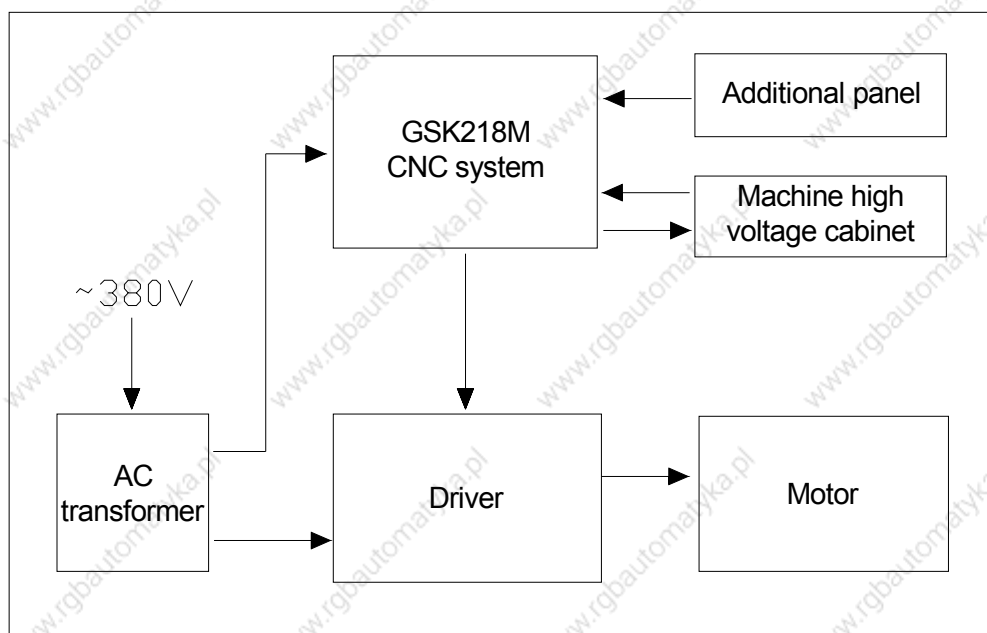

Fig. 1.1

1.2 System installation & connection

Firstly, check if the CNC system, driver, motor, and photoelectric encoder are ready, intact and matched.

The CNC system must be fixed stably, and there is some space around the system to ensure the air circulates, and the heat radiates. The installation position of CNC system must be convenient to the operation and avoid the position of processing chip and cooling.

The high/low voltage should be separated. The power supplies of CNC system and driver are provided by transformer, which are separated from the machine high voltage. All kind of signal line should be far from AC contactor to avoid the interference. The photoelectric encoder, limit signal and emergency stop signal should be directly connected to the CNC system. The power supply must be strictly grounded.

All kind of plug and bolt must be fixed stably, and forbide the signal connector is ON/OFF after

the CNC system is turned on.

The system panel cannot be damaged by hard thing and sharp weapon when the CNC system is installed; the CNC system should be carried down to avoid dirtying the system panel.

There is no the source of high voltage, magnetic field around the CNC system, and the system should be far from the inflammable, explosive substance and all sort of dangerous thing.

1.3 CNC system installation dimension

1. Front view

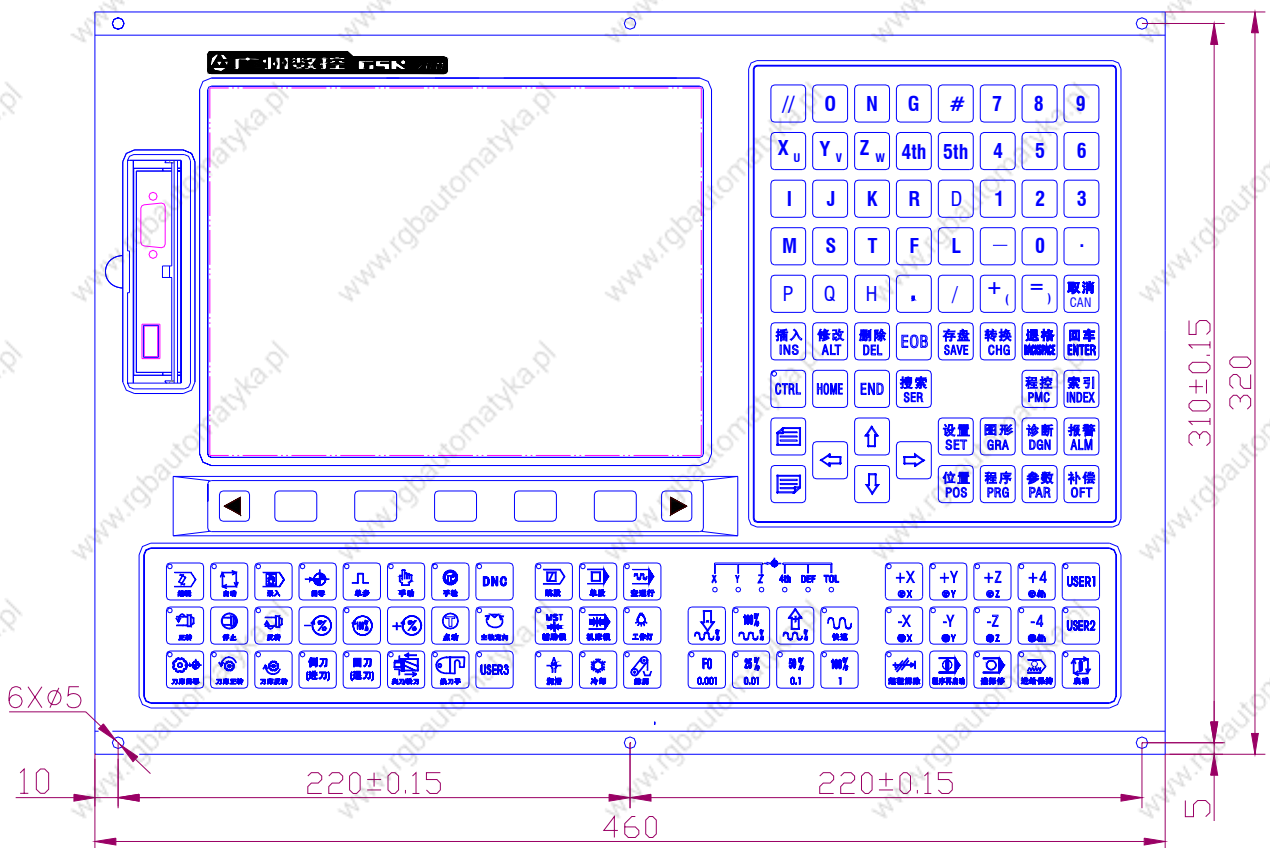

2. Side view

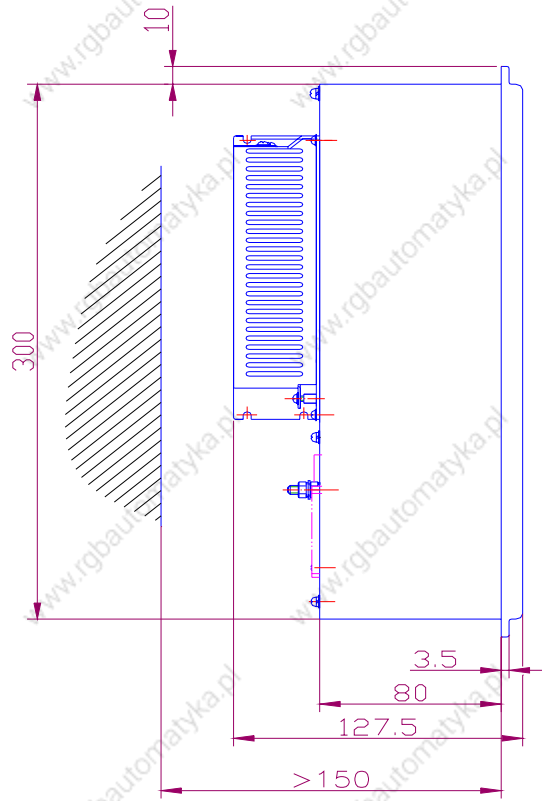

3. Overlook

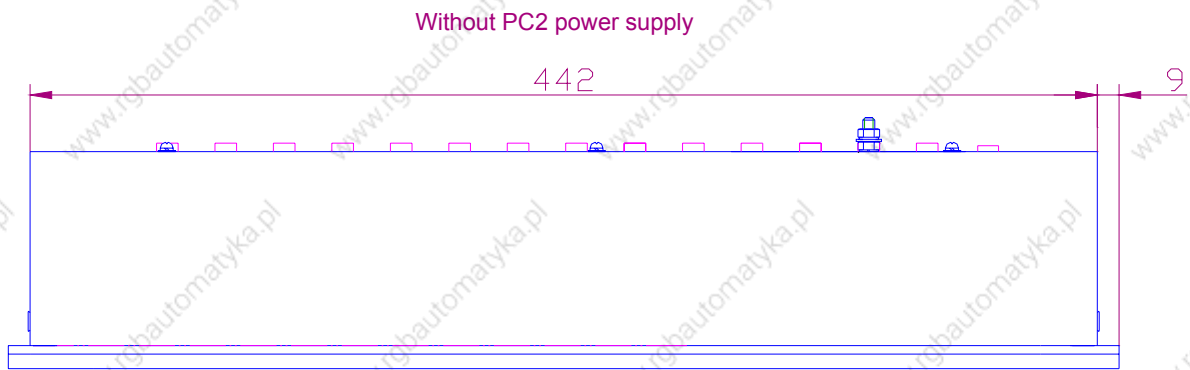

4. Back view

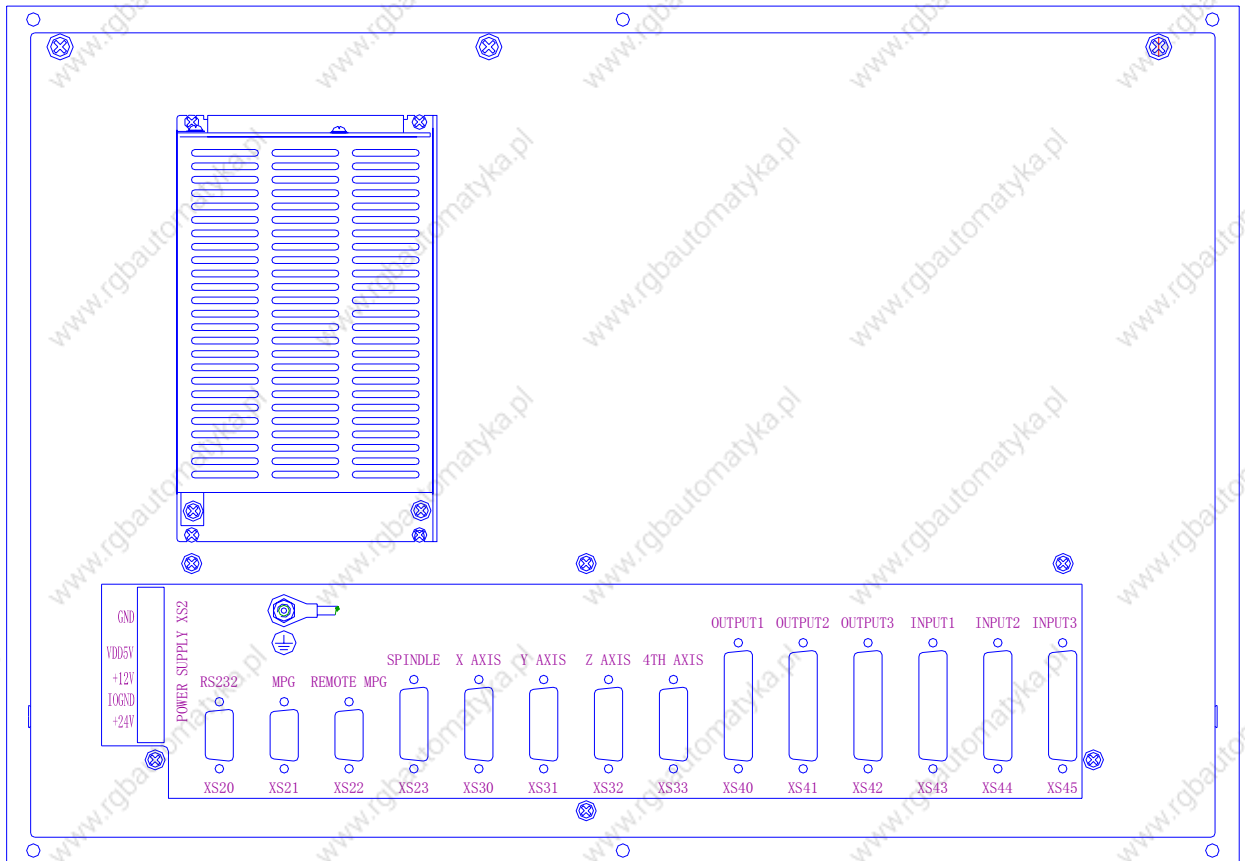

2 Device Connection

2.1 CNC external connection

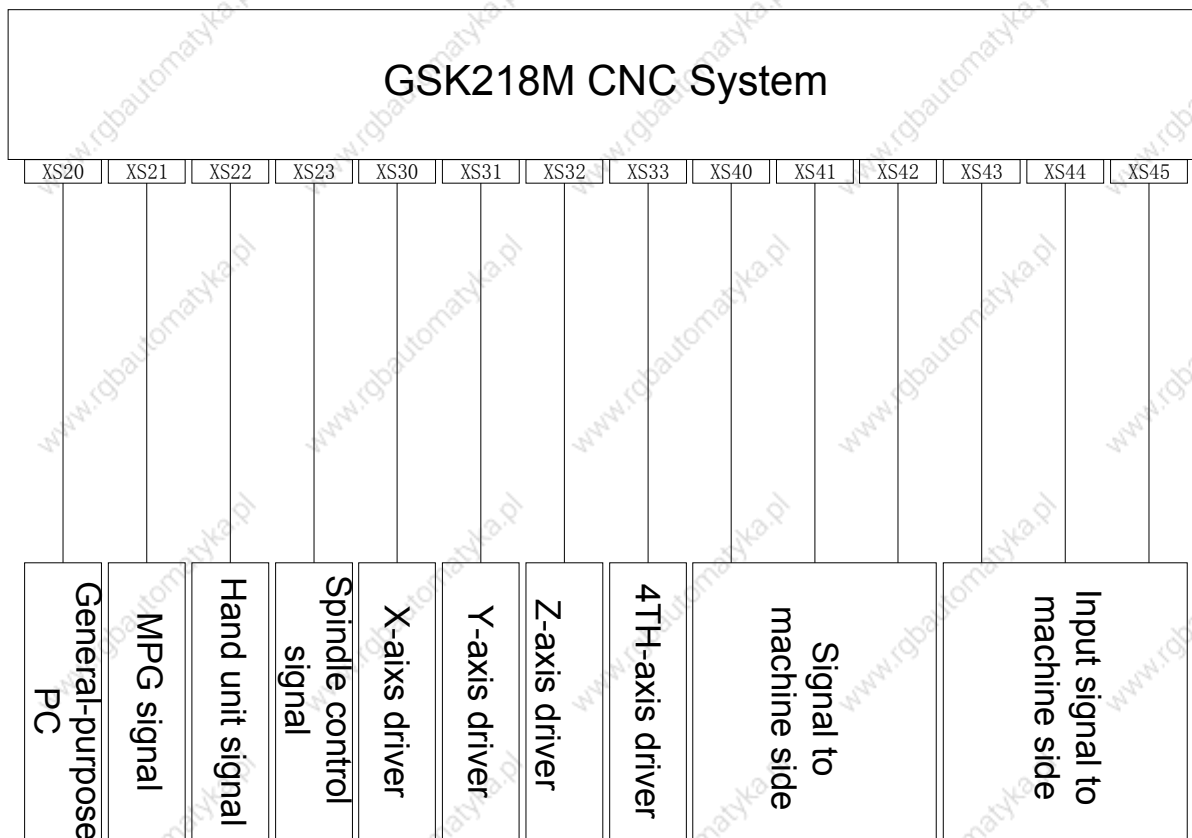

2.2 Connection between system and driver

Interfaces to driver include XS30 (X axis) , XS31 (Y axis) , XS32 (Z axis) , XS33 (4TH axis) .

2.2.1 System interface

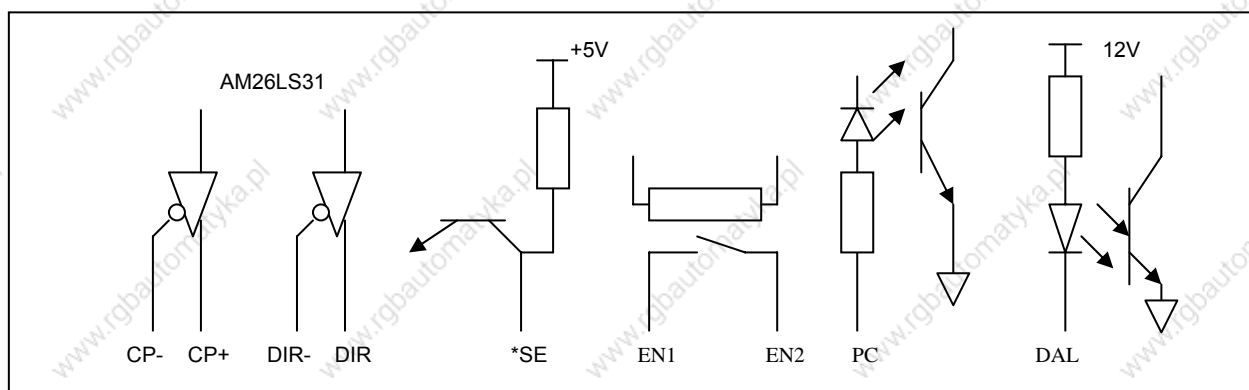

2.2.2 Interface signal list

XS30: DB15 female (X axis)

1	XCP+	9	XCP-
2	XDIR+	10	XDIR-
3	XPC	11	0V
4	+24V	12	+5V
5	XDALM	13	+5V
6		14	0V
7	XEN	15	0V
8	0V		

XS31: DB15 female (Y axis)

1	YCP+	9	YCP-
2	YDIR+	10	YDIR-
3	YPC	11	0V
4	+24V	12	+5V
5	YDALM	13	+5V
6		14	0V
7	YEN	15	0V
8	0V		

XS32: DB15 female (Z axis)

1	ZCP+	9	ZCP-
2	ZDIR+	10	ZDIR-
3	ZPC	11	0V
4	+24V	12	+5V
5	ZDALM	13	+5V
6		14	0V
7	ZEN	15	0V
8	0V		

XS33: DB15 female (4TH axis)

1	4CP+	9	4CP-
2	4DIR+	10	4DIR-
3	4PC	11	0V
4	+24V	12	+5V
5	4DALM	13	+5V
6		14	0V
7	4EN	15	0V
8	0V		

2.2.3 Signal specification

1) Pulse motion instruction signal

XCP+, XCP-, YCP+, YCP-, ZCP+, ZCP-, 4CP+, 4CP- are instruction pulse signals, XDIR+, XDIR-, YDIR+, YDIR-, ZDIR+, ZDIR-, 4DIR+, 4DIR- are motion direction signal, and they are differential signals.

Connection is as follows:

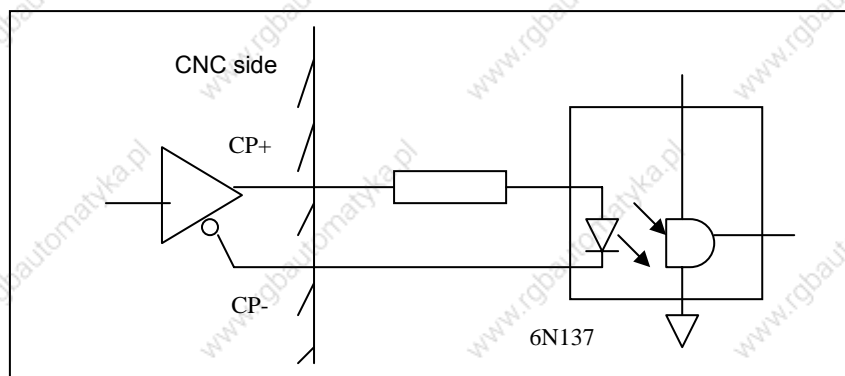

Fig. 2-2-3-1

2) Driver alarm signal ALM (input)

The receiving method of signal at the CNC side is as follows. The parameter 019bit0 set if the driver fault is the low level "0" or the high level.

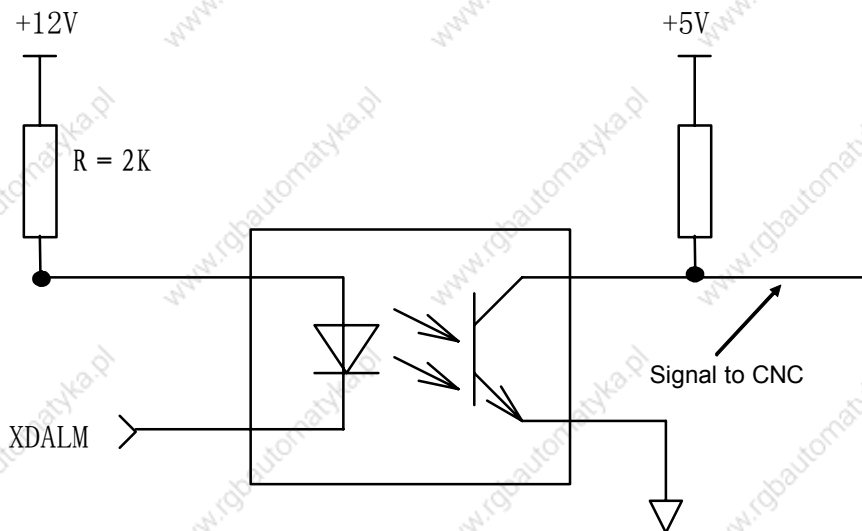

Fig. 2-2-3-2

The enabled level to the CNC can be set by customer if the low or the high is enabled. But the driver must provide the signal as follows:

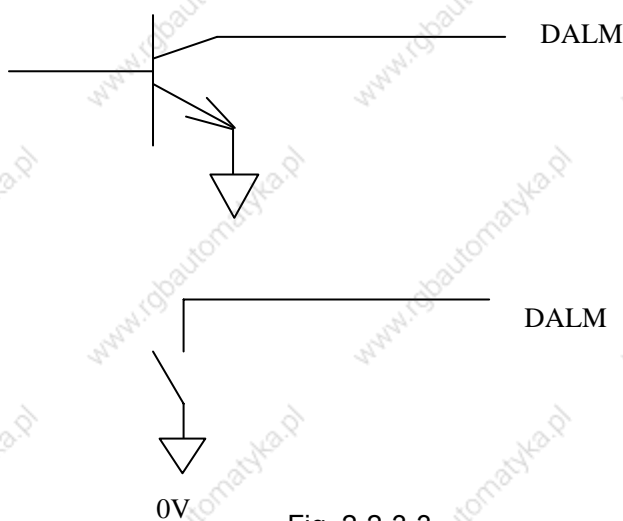

Fig. 2-2-3-3

3) CNC ready completion signal EN(contact output) CNC

CNC ready has been completed when the contact is closed. When CNC has detected the alarm, the contact signal is OFF.

4) Referece point return with signal PC

The receiving method of signal at the CNC side is as follows.

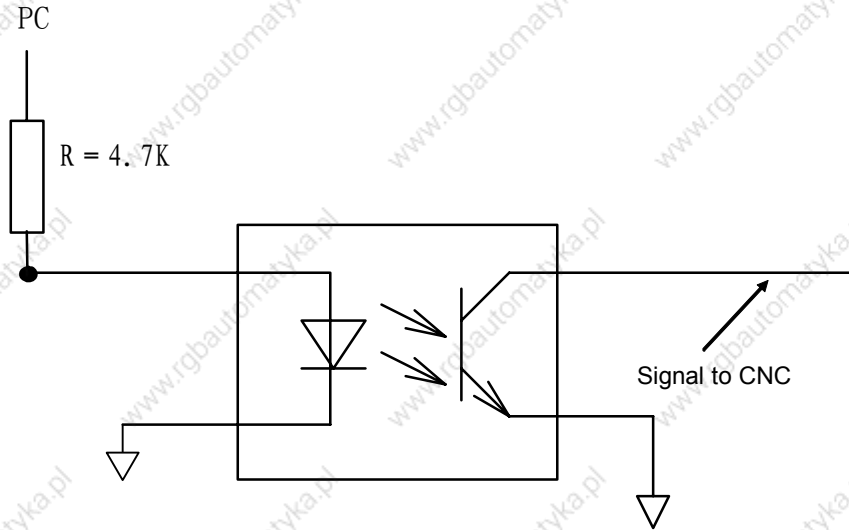

Fig. 2-2-3-4

Wave of PC signal provided by customer is as follows:

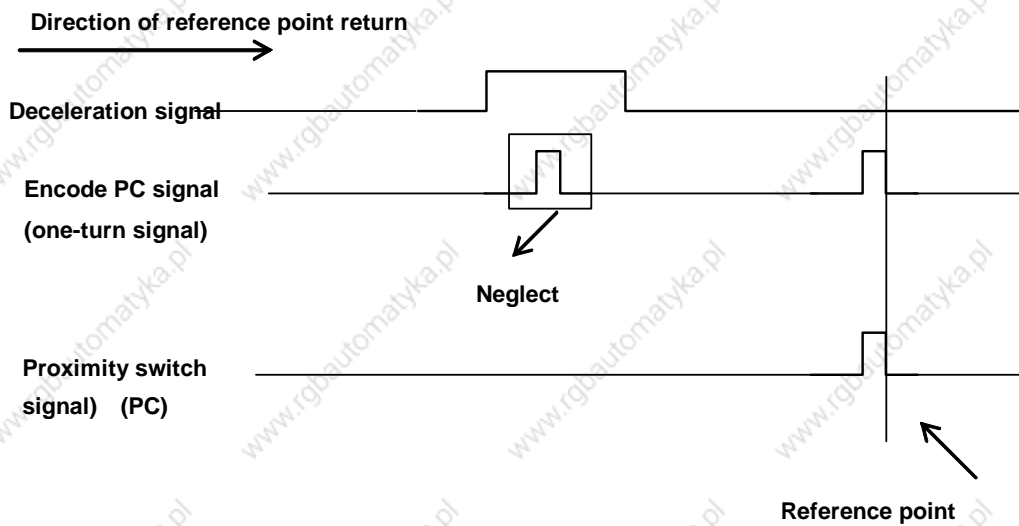

Fig. 2-2-3-5

5) Connection method of one proximity switch as the deceleration switch and zero return switch.

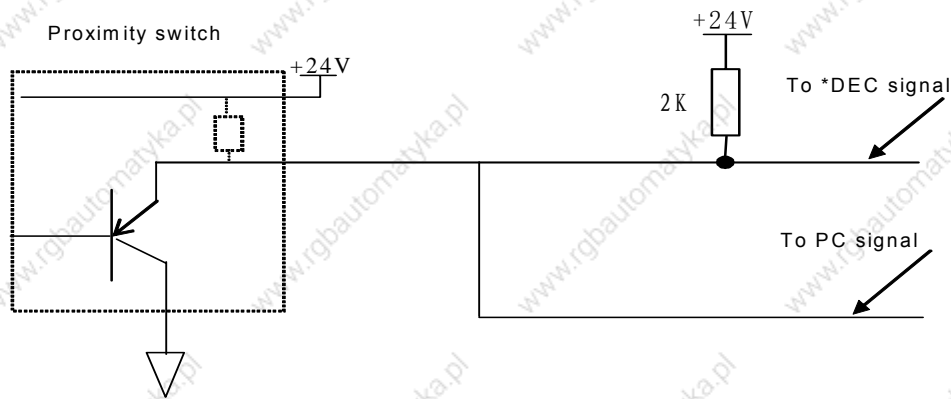
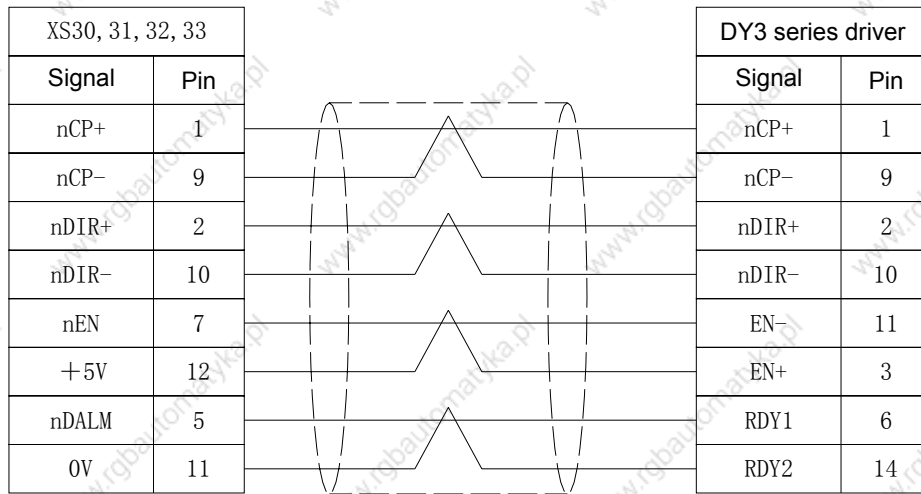

Fig. 2-2-3-6

2.2.4 Cable connection

1. Cable for 218M connecting with DY3 series driver



2. Cable for 218M connecting with DA98 series servo driver

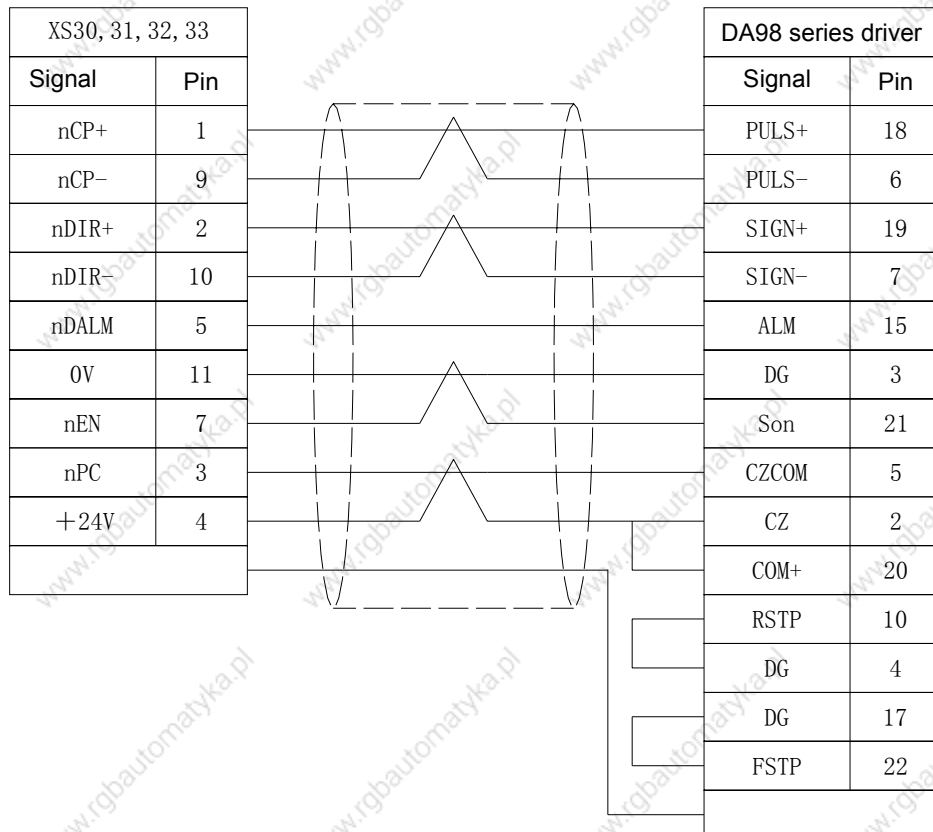

2.3 RS232 standard serial interface

GSK218M CNC system can communicate with the general-purpose PC (must match with 218M communication software) by RS232-C. Its connection is as follows:

Connection of cable is as follows:

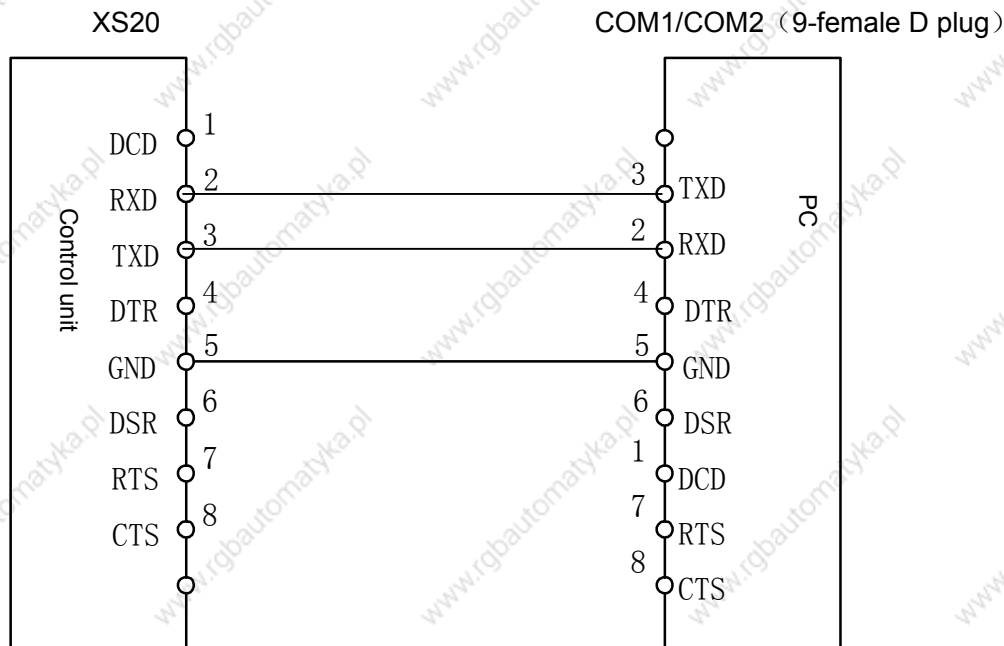

2.4 MPG(handwheel), hand unit connection

2.4.1 Interface signal list

The 218M CNC system can be matched with MPG or hand unit. When it is matched with MPG, the MPG signal is connected to XS21 interface; with hand unit, the MPG signal of hand unit is connected to XS21 interface and other signals are connected to XS22.

XS21: DB9 female

1	+5V	6	VCOM
2	HA+	7	HA-
3	HB+	8	HB-
4	ESP1	9	ESP2
5	0V		

XS22: DB9 female

1	+5V	6	HX
2	HY	7	HZ
3	HU	8	H*1
4	H*10	9	H*100
5	0V		

2.4.2 Interface signal

HA+, HA-, HB+, HB-: MPG pulse signal;

ESP1, ESP2: hand unit emergency stop signal;

HX, HY, HZ, HU: are separately axis select signal of X, Y, Z, 4TH.

H*1, H*10, H*100: are separately the override of MPG pulse equivalent;
 VCOM: hand unit common terminal.

2.5 Spindle unit connection

2.5.1 Interface signal list

The CNC interface is DB15 male and its pduring definition is as follows:

XS23: DB15 male

1	SCOM	9	SVC
2		10	A+
3	A-	11	B+
4	B-	12	Z+
5	Z-	13	SDALM
6	+5V	14	
7	AxisEN	15	+24V
8	COM		

2.5.2 Interface signal:

- (1) A+, A-, B+, B-, Z+, Z-: pulse signal of spindle encode;
- (2) SVC: spindle analog voltage signal;
- (3) SCOM: spindle analog power signal ground;
- (4) SDALM: spindle alarm input signal;
- (5) AxisEN: spindle enable signal.

2.6 Power supply interface

The input voltage of the CNC has two groups: +5V, +24V, among which +5V is for the CNC internal system, and +24V for external interface. The power supply interface is as follows:

9	GND2
8	GND2
7	
6	+5V
5	+5V
4	
3	GND1
2	
1	+24V

3 Machine Control I/O Interface

3.1 Interface signal list

XS40: DB25 female

1	D000	14	D001
2	D002	15	D003
3	COM	16	+24V
4	+24V	17	D004
5	D005	18	D006
6	D007	19	COM
7	+24V	20	+24V
8	D008	21	D009
9	D010	22	D011
10	COM	23	+24V
11	+24V	24	D012
12	D013	25	D014
13	D015		

XS41: DB25 female

1	D016	14	D017
2	D018	15	D019
3	COM	16	+24V
4	+24V	17	D020
5	D021	18	D022
6	D023	19	COM
7	+24V	20	+24V
8	D024	21	D025
9	D026	22	D027
10	COM	23	+24V
11	+24V	24	D028
12	D029	25	D030
13	D031		

XS42: DB25 female

1	D032	14	D033
2	D034	15	D035
3	COM	16	+24V
4	+24V	17	D036
5	D037	18	D038
6	D039	19	COM
7	+24V	20	+24V
8	D040	21	D041
9	D042	22	D043
10	COM	23	+24V
11	+24V	24	D044
12	D045	25	D046
13	D047		

XS43: DB25 male

1	IN00	14	IN01
2	IN02	15	IN03
3	COM	16	COM
4	+24V	17	IN04
5	IN05	18	IN06
6	IN07	19	COM
7	COM	20	+24V
8	IN08	21	IN09
9	IN10	22	IN11
10	COM	23	COM
11	+24V	24	IN12
12	IN13	25	IN14
13	IN15		

XS44: DB25 male

1	IN16	14	IN17
2	IN18	15	IN19
3	COM	16	COM
4	+24V	17	IN20
5	IN21	18	IN22
6	IN23	19	COM
7	COM	20	+24V
8	IN24	21	IN25
9	IN26	22	IN27
10	COM	23	COM
11	+24V	24	IN28
12	IN29	25	IN30
13	IN31		

XS45: DB25 male

1	IN32	14	IN33
2	IN34	15	IN35
3	COM	16	COM
4	+24V	17	IN36
5	IN37	18	IN38
6	IN39	19	COM
7	COM	20	+24V
8	IN40	21	IN41
9	IN42	22	IN43
10	COM	23	COM
11	+24V	24	IN44
12	IN45	25	IN46
13	IN47		

Fig. 3-1

XS40, XS41, XS42 are output interfaces (DB25 female), XS43, XS44, XS45 are input interface.

3.2 Input interface

3.2.1 Input interface method

DC input signal A

DC input signal A is from the machine to the CNC, and they are from the press key at the machine side, limit switch and contact of relay.

a) Contacts at the machine side should meet the following:

Contact capacity: over DC30V, 16mA.

Leak current between contacts during open circuit: below 1mA(voltage 26.4).

Voltage-drop between contacts during closed-circuit: below 2V(current 8.5mA, including voltage-drop of cable).

b) Signal loop is as Fig 3-2-1-1:

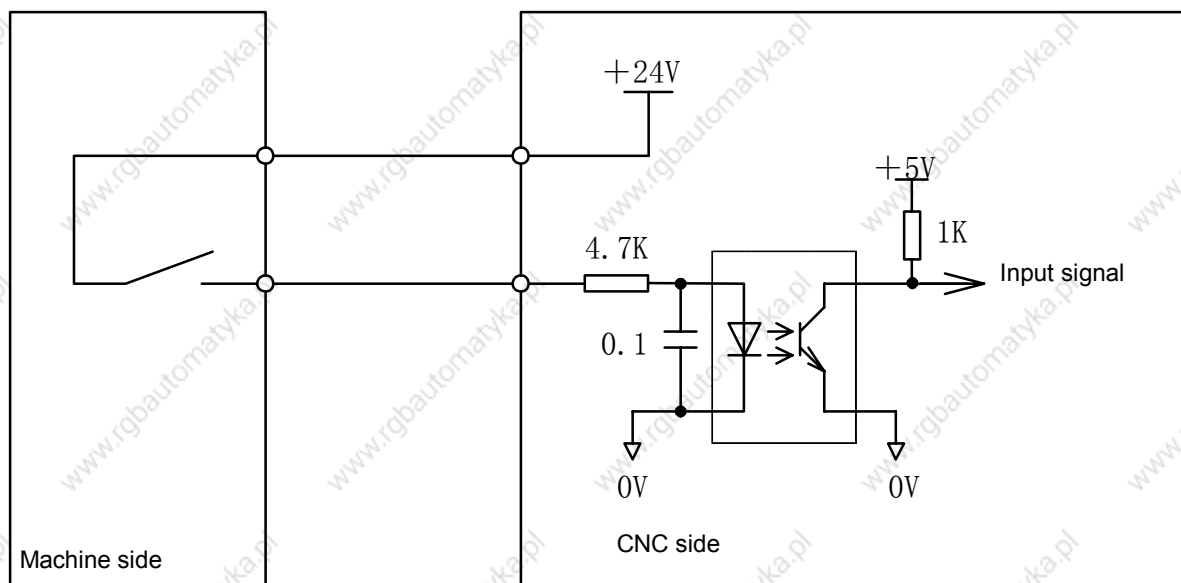

Fig. 3-2-1-1

3.2.2 Input signal interface definition

During definition of input interface is as follows:

XS43 input 1

Pin	Markign	Label	Function
1	IN00	X0.0	X-axis positive travel limit switch is enabled when the normally close contact is OFF.
14	IN01	X0.1	X-axis negative travel limit switch is enabled when the normally close contact is OFF.
2	IN02	X0.2	Y-axis positive travel limit switch is enabled when the normally close contact is OFF.
15	IN03	X0.3	Y-axis negative travel limit switch is enabled when the normally close contact is OFF.
17	IN04	X0.4	Z-axis positive travel limit switch is enabled when the

			normally close contact is OFF.
5	IN05	X0.5	Z-axis negative travel limit switch is enabled when the normally close contact is OFF.
18	IN06	X0.6	4-axis positive travel limit switch is enabled when the normally close contact is OFF.
6	IN07	X0.7	4-axis negative travel limit switch is enabled when the normally close contact is OFF.
8	IN08	X1.0	X-axis positive travel limit switch is enabled when the normally close contact is OFF.
21	IN09	X1.1	Y-axis zero return deceleration switch is enabled when the normally close contact is OFF.
9	IN10	X1.2	Z-axis zero return deceleration switch is enabled when the normally close contact is OFF.
22	IN11	X1.3	4-axis zero return deceleration switch is enabled when the normally close contact is OFF.
24	IN12	X1.4	The emergency stop switch is enabled when the normally close contact is OFF.
12	IN13	X1.5	The external cycle start is enabled when the normally close contact is OFF.
25	IN14	X1.6	The external feed hold is enabled when the normally close contact is OFF.
13	IN15	X1.7	The press check switch is enabled when the normally close contact is OFF.

XS44 input 2

Pin	Markign	Label	Function
1	IN16	X2.0	The lubricant low is enabled when the normally close contact is OFF.
14	IN17	X2.1	The tool change permission is enable when the normally close contact is OFF.
2	IN18	X2.2	-axis zero return deceleration switch is enabled when the normally close contact is OFF.
15	IN19	X2.3	-axis zero return deceleration switch is enabled when the normally close contact is OFF.
17	IN20	X2.4	Undefined
5	IN21	X2.5	The tool release check is enabled when the normally close contact is OFF.
18	IN22	X2.6	The tool clamp check is enabled when the normally close contact is OFF.
6	IN23	X2.7	The spindle overheat is enabled when the normally close contact is OFF.
8	IN24	X3.0	Undefined
21	IN25	X3.1	Undefined
9	IN26	X3.2	Undefined

22	IN27	X3.3	Undefined
24	IN28	X3.4	Undefined
12	IN29	X3.5	Undefined
25	IN30	X3.6	Undefined
13	IN31	X3.7	Undefined

XS45 input 3

Pin	Markign	Label	Function
1	IN32	X4.0	Undefined
14	IN33	X4.1	The spindle gear stage 1 completion is enabled when the normally close contact is ON.
2	IN34	X4.2	The spindle gear stage 2 completion is enabled when the normally close contact is ON.
15	IN35	X4.3	The spindle gear stage 3 completion is enabled when the normally close contact is ON.
17	IN36	X4.4	Undefined
5	IN37	X4.5	Undefined
18	IN38	X4.6	The spindle speed completion is enabled when the normally close contact is ON.
6	IN39	X4.7	The spindle zero speed check is enabled when the normally close contact is ON.
8	IN40	X5.0	The spindle orientation completion is enabled when the normally close contact is ON.
21	IN41	X5.1	The tool magazine forward completion is enabled when the normally close contact is ON.
9	IN42	X5.2	The tool magazine backward completion is enabled when the normally close contact is ON.
22	IN43	X5.3	The tool magazine count is enabled when the normally close contact is ON. 刀
24	IN44	X5.4	The tool magazine zero return is enabled when the normally close contact is ON.
12	IN45	X5.5	The tool magazine air source check is enabled when the normally close contact is ON.
25	IN46	X5.6	Undefined
13	IN47	X5.7	The spindle alarm is enabled when the normally close contact is ON.

3.3 Output signal

3.3.1 Output interface method

a) Output transistor specification:

- ① When the output is ON, max. load current, including instantaneous current is below

200mA.

- ② When the output is ON and the current is 200mA, the saturation voltage is 1.6V and the typical value is 1V .
- ③ When the output is OFF, the withstand voltage including instantaneous voltage is below 24+20%.
- ④ When the output is OFF, the leak current is below 100μA.

b) Output loop:

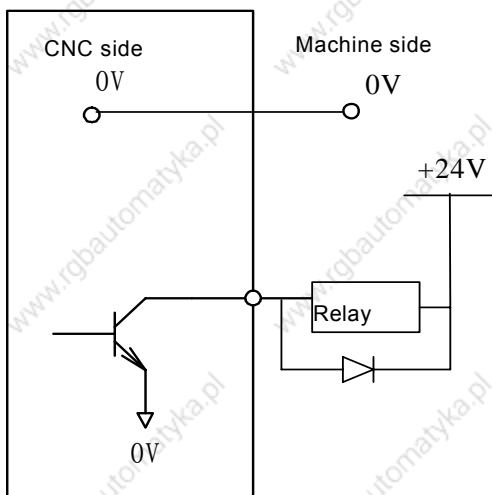

Fig. 3-3-1-1

The output signals of the CNC are provided by Darlington pipe and Darlington pipe is conducted when the output is enabled. Except for TL-, TL+, SPZD are pulse signals, other outputs are the level signal and their common terminal is 24V.

3.3.2 Output signal interface definition

XS40 output 1

Pin	Markign	Label
1	DO00	Y0.0
14	DO01	Y0.1
2	DO02	Y0.2
15	DO03	Y0.3
17	DO04	Y0.4
5	DO05	Y0.5
18	DO06	Y0.6
6	DO07	Y0.7
8	DO08	Y1.0
21	DO09	Y1.1
9	DO10	Y1.2
22	DO11	Y1.3
24	DO12	Y1.4
12	DO13	Y1.5
25	DO14	Y1.6

13	DO15	Y1.7
----	------	------

XS41 Output 2

Pin	Markign	Label
1	DO16	Y2.0
14	DO17	Y2.1
2	DO18	Y2.2
15	DO19	Y2.3
17	DO20	Y2.4
5	DO21	Y2.5
18	DO22	Y2.6
6	DO23	Y2.7
8	DO24	Y3.0
21	DO25	Y3.1
9	DO26	Y3.2
22	DO27	Y3.3
24	DO28	Y3.4
12	DO29	Y3.5
25	DO30	Y3.6
13	DO31	Y3.7

XS42 output 3

Pin	Markign	Label
1	DO32	Y4.0
14	DO33	Y4.1
2	DO34	Y4.2
15	DO35	Y4.3
17	DO36	Y4.4
5	DO37	Y4.5
18	DO38	Y4.6
6	DO39	Y4.7
8	DO40	Y5.0
21	DO41	Y5.1
9	DO42	Y5.2
22	DO43	Y5.3
24	DO44	Y5.4
12	DO45	Y5.5
25	DO46	Y5.6
13	DO47	Y5.7

4 Debugging Machine

The chapter introduces the trial operation methods and steps after GSK218M CNC system is turned on firstly, and the corresponding machine operation can be performed after the following steps are done.

4.1 Debug preparation

GSK218M debug is as follows:

- System connection: the correct connection is the basis to successfully debug the system.
- PLC debug: it makes the safety functions(emergency stop, hardward limit) and operation functons be effective.
- Parameter setting of driver:set the motor tyte and control mode.
- Parameter setting of system: set the control parameter, speed parameter and so on.
- Data backup: after the system is debugged, the data including the parameter, the compensation data and PLC program is backuped.

Notes before debugging GSK218M:

- To ensure all cables are connected correctly, please check the polarity of diode of relay, electromagnetic valve.
- Check the connection phase sequence of cable with high voltage of motor.
- The position cable, encoder feedback cable and motor cable with high voltage of AC servo feed device correspond one by one.
- Ensure the analog voltage instruction type received by the spindle.
- Ensure all earthing are stably connected.
- Ensure the emergency stop button and emergency stop circuit are valid. When the emergency stop button or emergency stop circuit is turned off, the power supply of drive device, spindle drive device can be turned off.
- Ensure the voltage and the polarity are correct.
- Ensure the specifications of power supply are correct.
- Ensure the specifications and the inlet/outlet directions of transformer are correct.
- Ensure the inlet/outlet lines of power supply of breakers are correct.

4.2 System power on

- Press the emergency stop button to ensure all air switches during the CNC are turned off.

System parameter number

0	3	1	G23						
---	---	---	-----	--	--	--	--	--	--

G23 =1: The soft limit function is ON when the power is turned on.

=0: The soft limit function is OFF when the power is turned on.

$$G = \frac{\text{Division numerator}}{\text{Division denominator}}$$

Division numerator: command multiplying coefficient (system parameter NO.160, NO.161, NO.162, NO.163, NO.164)

Division denominator: command division coefficient (system parameter NO.165, NO.166, NO.167, NO.168, NO.169)

P: pulse quantity of input command;

G: electronic gear ratio;

N: motor rotation rev;

C: photoelectric encoder lines/rev, the system C=2500.

【Example】 When the input instruction pulse is 6000, the servo motor rotates 1 rev.

$$G = \frac{N \times C \times 4}{P} = \frac{1 \times 2500 \times 4}{6000} = \frac{5}{3}$$

Data parameter NO. 160 (CMRX) =5, NO.165 (CMDX) =3;

The ratio between the system gear and the parameter has the same function that of digital servo gear and parameter. When the system is employed with the digital servo with the electronic gear ratio function, the electronic gear ratio is set to 1:1, which is set to the digital servo.

When the CNC is adopted with the stepper driver, it should use the stepper division driver as possible, v and the proper machine driving ratio, and set the electronic gear ratio to 1:1 to avoid the large difference between the numerator and denominator.

4.5 Backlash compensation

Use the gauge, micrometer gauge or laser master gauge to measure the backlash, the backlash compensation must be precise, otherwise it cannot improve the precision of processing and it is suggested that the following methods should be adopted to measure the leading screw backlash instead of MPG(handwheel) or single step:

- Edit program:

```
O0001;
N10 G01 G91 X1 F800 ;
N20 X1 ;
N30 X1 ;
N40 X-1 ;
N50 M30 .
```

- The backlash error compensation value is set to zero before measuring.
- The program runs during Single block mode, and the CNC looks for the measure datum point A after positioning two times, the program runs 1mm and reversly runs 1mm to B point, and the CNC reads the current data.

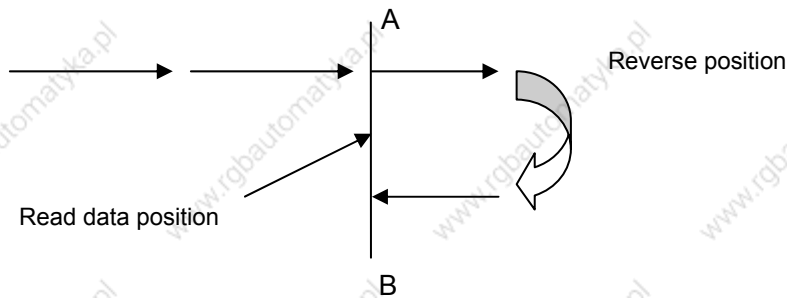

Fig. 4-5-1 backlash measure method

- Backlash error compensation value= |data recorded by A point –data recorded by B point|;
input the operation result to the system parameter No.190.

Data A: read the data of gauge at the A point;

Data B: read the data of micrometer gauge at the B point;

Pulse equivalent: 1 micron

Note: 1. The system parameter NO.195~NO.199 can set the backlash compensation mode and the compensation frequency.

2. To get the high precision, the backlash must be checked after the machine has been used for 3 months.

4.6 Parameter for servo

System parameter number

0	1	8	RVCS			RBK	FFR			
---	---	---	------	--	--	-----	-----	--	--	--

FFR =1: in feedforward control mode, the cutting feed and rapid traverse are enabled.

=0: In feedforward control mode, only cutting feed is enabled.

RBK =1: the cutting feed and the rapid traverse separately executes the backlash.

=0: the cutting feed and the rapid traverse does not execute separately the backlash.

4.7 Machine pitch compensation

- Setting compensation value

- ① The set compensaton value is related to the position between the zero and compensation poin, machine move direction and compensation backlash and so on.
- ② The compensation value of compensation point N(N=0,1,2,3,...127) is determined by the machine error between N, N-1.
- ③ The machine zero is taken as the compensation origduring point, and the set compensation of every axis is taken as the parameter value.
- ④ Compensable axis: X, Y, Z, 4, 5 axis. Compensation points: 128 points for each axis.
- ⑤ Compensation value range: each compensation point (-7~+7) ×compensation override. The input exceeding -7~+7 is disabled.
- ⑥ The setting method is the same that of input method of system parameter, see Operation.

- Notes for compensation value setting

- ① System parameter 216~220: pitch error compensation number of reference point of each axis(setting of compensation zero).
- ② System parameter 221~225: compensation points of pitch error compensation of each axis
- ③ System parameter 226~230: pitch error compensation backlash of each axis. Execute the compensation with the value when the positive cocompensation value is input; execute the compensation with the absolute value of the value when the negative compensation value is input
- ④ System parameter 231~235: pitch error compensation override of each axis. The CNC

defaults 0.001.

- ⑤ The compensation is not executed when the input compensation backlash is zero.
- ⑥ After the pitch error parameter is set, the CNC is turned on again, and the pitch error parameter is enabled after the machine zero return is executed.

- The following is the compensation parameters, taking X axis as example:

Parameter	Setting value
NO.216: compensation number of X-axis reference point	0
NO.221: X-axis pitch error compensation points	128
NO.226: X-axis pitch error compensation backlash	10
NO.231: X-axis pitch error compensation override	0.001

The error compensation takes the machine zero as reference point. The pitch error compensation is executed when the positive coordinate system of machine zero is moving.

The set compensation value during 【Pitch compensation X】.

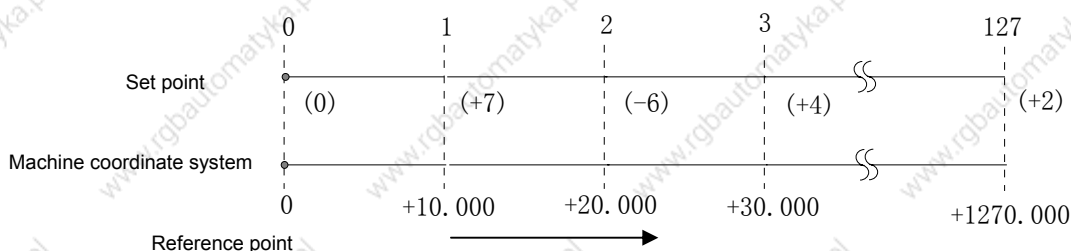

The displayed compensation points during compensation list take the set compensation points as the reference, corresponding to the reference point (pitch error orig during 0), the compensation point 1 corresponds to the position which is 10.000 from the reference point, the increment of 10.000 after it is taken as one compensation point, and the compensation value of No.127 compensation point is at 1270.000. So, at the compensation parameter number 0 during 【Compensation X】, set the compensation value from 0 to 10.000, and set the compensation value from 10.000 to 20.000 at the compensation point 1. For the compensation point N, the CNC sets the compensation value from $N \times (\text{compensation backlash})$ to $(N + 1) \times (\text{compensation backlash})$.

Actually, when the machine moves to +30.000 from the reference point, the compensation value of pitch error is:

$$(+7) + (-6) + (+4) = +5$$

- Bidirectional compensation setting takes X axis as the example:

The error compensation takes the machine zero as the reference point. The pitch error

compensation can be executed when the positive/negative coordinate system of machine zero moves

Operation during the positive coordinate: the first compensation length is No. 000 set compensation value during 【Compensation X】, the second is that of No. 001 and the N is that of No. N-1.

Operation during the negative coordinate: the first compensation length is No. 1000 set compensation value during 【Compensation X】, the second is that of No. 1001 and the N is that of No. 1000+N-1.

Parameter	Setting value
NO.216: compensation number of X-axis reference point	40
NO.221: X-axis pitch error compensation points	128
NO.226: X-axis pitch error compensation during terval	50
NO.231: X-axis pitch error compensation override	0.001mm

Output the compensation value at the compensation point of corresponding area. The example for the compensation is as follows:

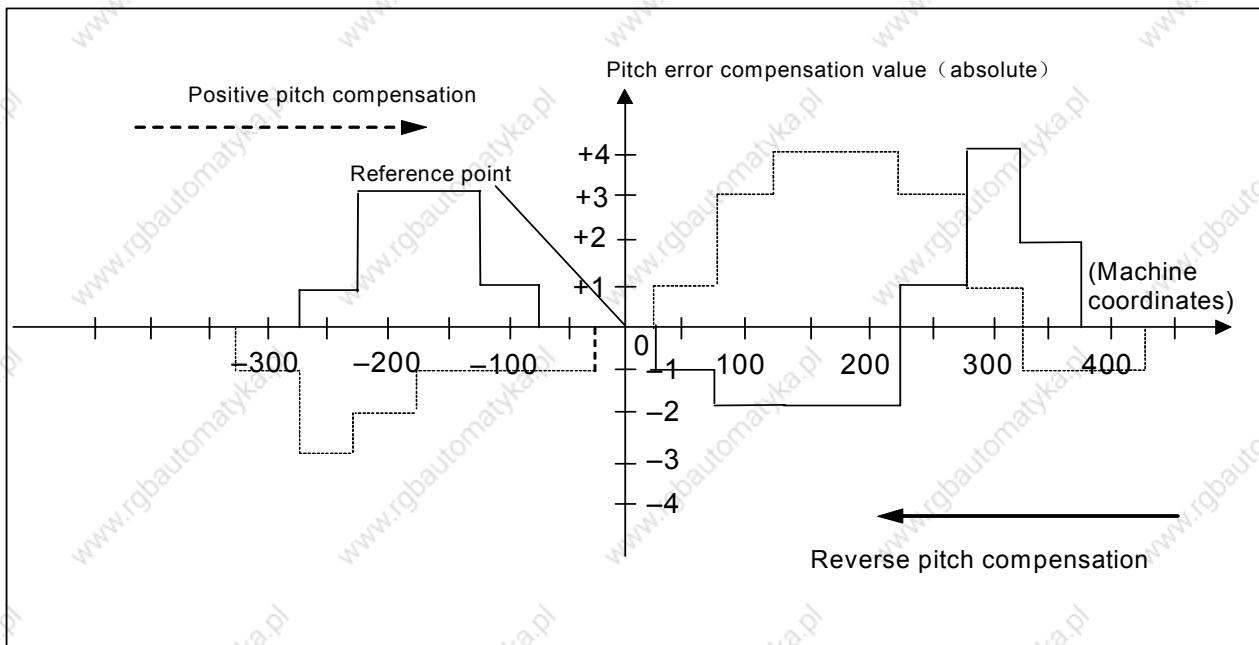

Positive pitch compensation (short line drawing):

Number	34	35	36	37	38	39	40	41	42	43	44	45	46	47	49
Compensation value	+1	+2	-1	-1	0	0	-1	+1	+3	+1	0	-1	-2	-2	+1

Negative pitch compensation (long line drawing):

Number	1034	1035	1036	1037	1038	1039	1040	1041	1042	1043	1044	1045	1046	1047
Compensation vlaue	-1	-2	0	+2	+1	0	-1	-1	0	0	+3	+3	-2	-2

The chapter mainly introduces modifying the position parameters and data parameters of CNC to realize the different funtions.

4.8 Debugging parameters

4.8.1 Machine zero return

- Signals

DECX: X-axis deceleration signal;

DECY: Y-axis deceleration signal;

DECZ: Z-axis deceleration signal;

DEC4: 4th-axis deceleration signal;

Parameter diagnosis(machine side input state)

State address					X1.3	X1.2	X1.1	X1.0
Pin					XS43.15	XS43.02	XS43.14	XS43.01

DEC =1: The machine zero return starts to decelerate when the deceleration signal is connected with 24V.

=0: The machine zero return starts to decelerate when the deceleration signal is not connected with 24V.

State parameter No.007

0	0	7	ZMI5	ZMI4	ZMIz	ZMIy	ZMIx		
---	---	---	------	------	------	------	------	--	--

ZMI =0 : The direction of machine zero return is positive.

=1 : The direction of machine zero return is negative.

State parameter No.006

0	0	6				JHZx			
---	---	---	--	--	--	------	--	--	--

JHZx =1: Use the deceleration dogs when the reference point return is executed after the reference point is set.

=0: Do not use the deceleration dogs when the reference point return is executed after the reference point is set.

State parameter No.011

0	1	1						ZNLK		
---	---	---	--	--	--	--	--	------	--	--

ZNLK =0 : When the zero return is executed, the direction key is not locked by its self by pressing it continuously.

=1 : When the zero return is executed, the direction key is locked, and the zero return runs to the zero to stop after the direction key is pressed one time. Upon "RESET", the zero return immediately stops during the zero return.

Data parameter No.099

0	9	9	ZRNFL							
---	---	---	-------	--	--	--	--	--	--	--

ZRNFL: low rate of X, Y, Z-axis reference point return(all axes).

Data parameters No.100~No.104

1	0	0	X-axis reference point return speed
1	0	1	Y-axis reference point return speed
1	0	2	Z-axis reference point return speed
1	0	3	4TH-axis reference point return speed
1	0	4	5TH-axis reference point return speed

Speed setting of all-axis reference point return

4.9 Input/output signal control of spindle CW/CCW

- Signals

M03: spindle CCW

M04: spindle CW

M05: spindle stop

ENB: spindle enable

SAR: spindle speed arrival

ZSPD: spindle zero speed check

Parameter diagnosis(machine side output state)

state address	Y1.7	Y1.6						
Pin	XS40.13	XS40.25						

Y1.6=spindle CCW signal output; Y1.7= spindle CW signal output.

state address		Y2.5					Y2.0
Pin		XS40.05					XS40.01

Y2.0=spindle enable; Y2.5=spindle zero speed clamp signal output

Parameter diagnosis(machine side input state)

state address	X4.7	X4.6						
Pin	XS45.06	XS45.18						

X4.6=spindle speed arrival signal input; X4.7=spindle zero speed check signal input.

Data parameter No.243

2	4	3	<input type="text"/>
---	---	---	----------------------

Spindle motor min. clamp speed .

Data parameter No.244

2	4	4	<input type="text"/>
---	---	---	----------------------

Spindle motor max. clamp speed.

Data parameter No.245

2	4	5	<input type="text"/>
---	---	---	----------------------

Time for check spindle speed arrival signal

Data parameter No.257

2	5	7	<input type="text"/>
---	---	---	----------------------

Spindle speed up limit during tapping cycle

Data parameter No.258

2	5	8	<input type="text"/>
---	---	---	----------------------

Spindle speed up limit

● Operation time sequence

Time sequence of spindle operation is as Fig. 3-3-1:



Fig. 3-3-1 Spindle CW time sequence

● Control logic

- ① The spindle stops and M05 outputs when CNC is turned on;
- ② After M3/M4 is executed, it is enabled and M05 stops output.

4.10 Spindle automatic gear change control

● Signals

Y3.4~Y3.6: Spindle automatic gear shift output signal

X4.1~X4.3: Spindle gear change completion signal

When CNC selects the spindle frequency conversion control (0~10V analog voltage output), it

can support 4-gear shpindle automatic gear change control and 4-gear change completion check function.

- Signal diagnosis

Parameter diagnosis(machine side output state)

state address		Y3.6	Y3.5	Y3.4			
Pin		XS44.25	XS44.12	XS44.24			

Y3.4=spindle gear 1 output; Y3.5=spindle gear 2 output; Y3.6=spindle gear 3 output.

Parameter diagnosis(machine side input state)

state address				X4.3	X4.2	X4.1	
Pin				XS45.15	XS45.02	XS45.13	

X4.1= spindle gear 1 in-position; X4.2=spindle gear 2 in-position; X4.3=spindle gear 3 in-position.

- Control parameter

State parameter No.001

0	0	1			Analog spindle			
----------	----------	----------	--	--	-----------------------	--	--	--

Bit4 =1: It must be set to 1 when the spindle automatic gear change function is performed during the spindle speed analog control mode.

=0: Spindle switch value control.

- Control parameter

State parameter

0	0	1				SPT		
----------	----------	----------	--	--	--	------------	--	--

SPT =1: Spindle control: I/O point.

=0: Spindle control: frequency conversion or other modes.

Data parameter No.246

2	4	6	
----------	----------	----------	--

Corresponding to max. speed of gear 1.

Data parameter No.247

2	4	7	
----------	----------	----------	--

Corresponding to max. speed of gear 2.

Data parameter No.248

2	4	8	
----------	----------	----------	--

Corresponding to max. speed of gear 3.

- Control logic

③ Upt to 1 of S1~S3 is enabled;

④ S1~S3 stops output after S0 is executed;

- ⑤ When some S** is executed, the corresponding S** output is enabled and kept, and CNC automatically stops other S** output.

4.11 External cycle start and feed hold

- Signals

ST: external automatic cycle start signal has the same function that of automatic cycle start key on the machine panel.

*SP: feed hold signal has the same function that of the feed hold key on the machine panel.

- Signal dianosis

Parameter diagnosis(machine side output state)

State address		X1.6	X1.5				
Pin		XS43.25	XS43.12				

- Internal circuit of signal

*SP/ST internal circuit is as Fig. 3-5-1:

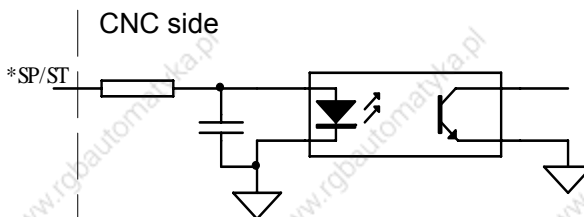

Fig.3-5-1

- External circuit

*SP, ST external circuit is as Fig. 3-5-2.

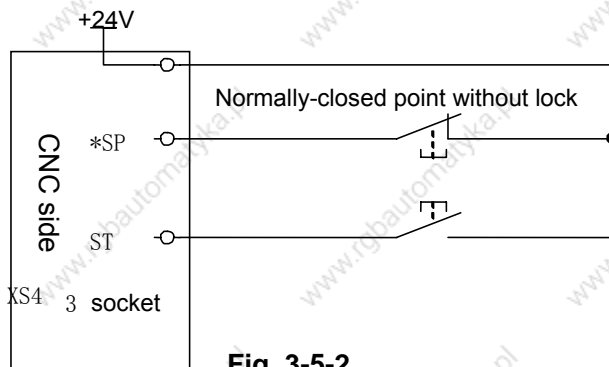

Fig. 3-5-2

4.12 Cooling, lubricant and chip removal control

- Signals
M08: cooling ON
M32: lubricant ON
M35: Chip removal ON

- Signal diagnosis

Parameter diagnosis(machine side output state)

State address							Y0.1	
Pin							XS40.14	

Y0.1=cooling switch control

Parameter diagnosis(machine side output state)

State address						Y1.2	Y1.1	
Pin						XS40.14	XS40.14	

Y1.1=chip removal switch control; Y1.2=lubricant switch control.

- Internal circuit is as Fig. 3-6-1:

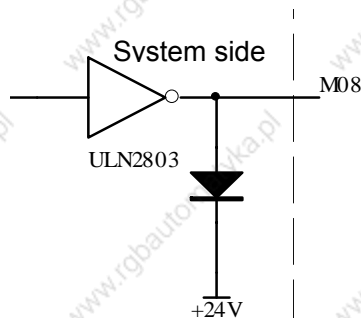

Fig.3-6-1 M08 internal circuit

4.13 Parameters of axis control

System parameter number

0	0	3			DIR5	DIR4	DIRZ	DIRY	DIRX	INM
---	---	---	--	--	------	------	------	------	------	-----

- INM** =1: Least instruction increment on the linear axis: inch.
=0: Least instruction increment on the linear axis: metric.
- DIRX** =1: X-axis feed direction.
=0: X-axis feed reverse.
- DIRY** =1: Y-axis feed direction.
=0: Y-axis feed reverse.
- DIRZ** =1: Z-axis feed direction.

=0: Z-axis feed reverse.

System parameter number

0	1	9	IOV		DEC		ITX			MALX
---	---	---	-----	--	-----	--	-----	--	--	------

MALX =1: When the driver alarms, high level is enabled.

=0: When the driver alarms, low level is enabled.

ITX =1: Each-axis lock signal is disabled.

=0: Each-axis lock signal is enabled.

System parameter number

0	0	4	IDG			XIK	AZR	SFD	DLZ	JAX
---	---	---	-----	--	--	-----	-----	-----	-----	-----

JAX =1: Simultaneous controlled axis during JOG, manual rapid, manual reference point mode: 3 .

=0: Simultaneous controlled axis during JOG, manual rapid, manual reference point mode: 1.

DLZ =1: Function for setting the reference point without dogs: enabled.

=0: Function for setting the reference point without dogs:disabled.

AZR =1: When the reference point is not set, G28: alarm.

=0: When the reference point is not set, G28: use dogs.

XIK =1: Non-linear positioning aixs is interlocked: all-axis stops moving.

=0: Non-linear positioning aixs is interlocked: interlock.

4.14 Parameter for coordinate system

System parameter number

0	0	9			AWK			ZCL		
---	---	---	--	--	-----	--	--	-----	--	--

ZCL =1: The local coordinate system is canceled when the manual reference point return is performed.

=0: The local coordinate system is canceled when the manual reference point return is not performed.

4.15 Parameter for feedrate

System parameter number

0	1	2		RDR	TDR	RFO			LRP	RPD
---	---	---	--	-----	-----	-----	--	--	-----	-----

RPD =1: Manual rapid traverse during the period from power-on time to the completion of the reference point return is enabled.

0091	4TH-axis rapid operation speed	5000
------	--------------------------------	------

Set range:0~9999.9999

0092	5TH-axis rapid operation speed	5000
------	--------------------------------	------

Set range: 0~9999.9999

0093	All-axis rapid operation override F0 speed (all axes)	30
------	---	----

Set range: 0~9999.9999

0094	Max. feedrate(all axes)	8000
------	-------------------------	------

Set range: 0~9999.9999

0095	Min. feedrate(all axes)	0
------	-------------------------	---

Set range:0~9999.9999

0096	Max. control speed during predict control mode(all axes)	6000
------	--	------

Set range: 0~9999.9999

0097	Min. control speed during predict control mode(all axes)	0
------	--	---

Set range: 0~9999.9999

0098	All-axis JOG continuous feedrate	2000
------	----------------------------------	------

Set range: 0~9999.9999

0099	Reference point return speed (all axes)	10
------	---	----

Set range: 0~9999.99990~9999.9999

0100	X-axis reference point return speed	2000
------	-------------------------------------	------

Set range:

0101	Y-axis reference point return speed	2000
------	-------------------------------------	------

Set range: 0~9999.9999

0102	Z-axis reference point return speed	2000
------	-------------------------------------	------

Set range: 0~9999.9999

0103	4TH-axis reference point return speed	2000
------	---------------------------------------	------

Set range: 0~9999.9999

0104	5TH-axis reference point return speed	2000
------	---------------------------------------	------

Set range: 0~9999.9999

4.16 Parameters for MDI, display and servo

System parameter number

0	1	8	RVCS			RBK	FFR			
---	---	---	-------------	--	--	------------	------------	--	--	--

FFR =1: Feed-forward control is enabled for cutting feed and rapid traverse.

=0: Feed-forward control is enabled for cutting feed only.

RBK =1: Backlash compensation applied separately for cutting feed and rapid traverse is performed.

0: Backlash compensation applied separately for cutting feed and rapid traverse is not performed.

4.16 Parameters of MDI, display and edit

System parameter number

0	2	0		COR					
---	---	---	--	------------	--	--	--	--	--

COR =1: Display: color.

=0: Display: monochrome.

System parameter number

0	2	2	DAC	DAL	DRC	DRL	PPD		MCN
---	---	---	------------	------------	------------	------------	------------	--	------------

MCN =1: The machine position is displayed according to the unit of input.

=0: The machine position is displayed regardless of the unit of input.

PPD =1: The relative position display is preset when a coordinate system is set.

=0: The relative position display is not preset when a coordinate system is set.

DRL =1: The relative position display takes into account the the tool length compensation.

=0: The relative position display does not take into account the the tool length compensation.

DRC =1: The relative position display takes into account the tool nose radius compensation.

=0: The relative position display does not take into account the tool nose radius compensation.

DAL =1: The absolute position display takes into account the tool length compensation.

=0: The absolute position display does not take into account the tool length compensation.

DAC =1: The absolute position display takes into account the tool nose radius compensation.

=0: The absolute position display does not take into account the tool nose radius compensation.

System parameter number

0	2	3	MDL	POSM		SUK		DNC		NAM
----------	----------	----------	------------	-------------	--	------------	--	------------	--	------------

NAM =1: Program list displays program number and program name.

=0: Program list displays program number.

DNC =1: Upon reset, the program display for DNC operation is cleared.

=0: Upon reset, the program display for DNC operation is not cleared.

SUK =1: The program list is displayed during order of program number.

=0: The program list is displayed during order of logging time.

POSM =1: The modal state on the program position screen is displayed.

=0: The modal state on the program position screen is not displayed.

MDL =1: The modal state on the program display screen is displayed.

=0: The modal state on the program display screen is not displayed.

System parameter number

0	2	4	RHD	NPA		SGD		SPS	SVS
----------	----------	----------	------------	------------	--	------------	--	------------	------------

NPA =1: It is switched to the alarm screen when CNC alarms.

=0: It is not switched to the alarm screen when CNC alarms.

RHD =1: The MPG halt relative position display is changed.

=0: The MPG halt relative position display is not changed.

0	2	9		MCM		IWZ	WZO	MCV	GOF	WOF
---	---	---	--	------------	--	------------	------------	------------	------------	------------

WOF =1: The tool offset value by MDI key input is disabled.

=0: The tool offset value by MDI key input is not disabled.

GOF =1: The tool geometric offset value by MDI key input is disabled.

=0: The tool geometric offset value by MDI key input is not disabled.

MCV =1: Macro variable setting by MDI input is disabled.

=0: Macro variable setting by MDI input is not disabled.

WZO =1: Setting a workpiece zero point offset value by MDI key input is disabled.

=0: Setting a workpiece zero point offset value by MDI key input is not disabled.

IWZ =1: Setting a workpiece zero point offset value by MDI key input during halt state is disabled.

=0: Setting a workpiece zero point offset value by MDI key input during halt state is not disabled.

MCM =1: The setting of custom macros by MDI key operation is enabled only during the MDI mode.

=0: The setting of custom macros by MDI key operation is enabled regardless of the mode.

System parameter number

0	2	8		MCL	MER	MEE	MKP				
---	---	---	--	------------	------------	------------	------------	--	--	--	--

MKP =1: The written program is cleared when M02, M30 or is executed in MDI mode.

=0: The written program is not cleared when M02, M30 or is executed in MDI mode.

MEE =1: The program is not edited during operation in MDI mode.

=0: The program can be edited during operation in MDI mode.

MER =1: The program can be edited during operation execution in MDI mode.

=0: The executed program is not deleted when the last has been executed in MDI mode.

MCL =1: Upon the reset key, the written program is deleted during MDI mode.

=0: Upon the reset key, the written program is not deleted during MDI mode.

System parameter number

0	3	0			ABS	MAB				DPI
---	---	---	--	--	------------	------------	--	--	--	------------

DPI =1: The decimal point during programming is omitted: mm,sec.

=0: The decimal point during programming is omitted: mduring setting unit.

MAB =1: Use parameters to set the absolute or relative during MDI mode.

=0: Use G90/G91 to set the absolute or relative during MDI mode.

ABS =1: The instruction is absolute during MDI mode.

=0: The instruction is relative during MDI mode.

4.17 Parameters for tool compensation

System parameter number

0	3	9		EVO		EVR		OFH	TLB	TLC
---	---	---	--	------------	--	------------	--	------------	------------	------------

TLC =1: Tool length compensation: B

=0: Tool length compensation: A

TLB =1: Tool length compensation axis: axis perpendicular to plane specification.

=0: Always Z axis irrespective of plane specification.

OFH =1: Specifies the tool length compensation, tool compensation and tool offset.

=0: Specifies the tool length compensation, tool compensation and tool offset.

EVR =1: Enables the change, starting from that block where buffering is next performed.

=0: Enables the change, starting from that block where the next block is specified.

EVO =1: A block to be buffered next and subsequent blocks becomes valid.

=0: A block specifying the next becomes valid.

System parameter number

0	4	0	ODI	LVK				CCN	SUV	SUP
---	---	---	------------	------------	--	--	--	------------	------------	------------

SUP =1: Start up during tool nose radius compensation : B

=0: Start up during tool nose radius compensation: A

SUV =1: G40,G41,G42: perpendicular

=0: G40,G41,G42: standard

CCN =1: The tool nose radius compensation vector is cancelled when G28 is during movement to an intermediate position.

=0: The tool nose radius compensation vector is not cancelled when G28 is during movement to an intermediate position.

LVK =1: Clear the tool length offset value by reset.

=0: Do not clear the tool length offset value by reset.

ODI =1: A tool nose radius compensation amount is set by diameter.

=0: A tool nose radius compensation amount is set by radius.

System parameter number

0	4	1	CNC	CN1	G39				OIM
---	---	---	------------	------------	------------	--	--	--	------------

OIM =1: When the unit is switched between the inch and metric systems, the automatic tool offset value conversion is performed.

=0: When the unit is switched between the inch and metric systems, the automatic tool offset value conversion is not performed.

G39 =1: The corner rounding function is enabled during radius compensation mode.

=0: The corner rounding function is disabled during radius compensation mode.

CN1 =1: The tool nose radius compensation (C) is executed the halt check.

=0: The tool nose radius compensation(C) is not executed the halt check.

Appendix:

Guide for GSK218M matching with ladder

1. Notices of GSK218M matching with turret tool magazine

- (1) Install wiring according to the ladder.
- (2) Set PMC parameters correctly to ensure that the ladder matches with the machine tool when the ladder is used
- (3) The machine tool has special control requirements. When the program is added to the ladder, the persons responsible for modification should be master the electric and PMC method, and the ladder.
- (4) The ladder is only suitable for general CNC milling machine and the machining center with the turret tool magazine, otherwise, other machine tools may result in the unexpected accident.
- (5) The ladder is referred, and the ladder is different for the different machine tool.

2. Allocation and definition of PMC IO address, auxiliary relay and register

Table 1 Input signal interface definition

Address	Definition	Contact selection	Remark
X0000	X axis positive travel limit signal	Normally closed contact	
X0001	X axis negative travel limit signal	Normally closed contact	
X0002	Y axis positive travel limit signal	Normally closed contact	
X0003	Y axis negative travel limit signal	Normally closed contact	
X0004	Z axis positive travel limit signal	Normally closed contact	
X0005	Z axis negative travel limit signal	Normally closed contact	
X0006	Th4 axis positive travel limit signal	Normally closed contact	
X0007	Th4 axis negative travel limit signal	Normally closed contact	
X0010	X axis zero return deceleration signal	Normally closed contact	
X0011	Y axis zero return deceleration signal	Normally closed contact	
X0012	Z axis zero return deceleration signal	Normally closed contact	
X0013	Th4 axis zero return deceleration signal	Normally closed contact	
X0014	Emergency stop switch	Normally closed contact	
X0015	External cycle start	Normally open contact	
X0016	External feed hold	Normally open contact	
X0017	Undefined		
X0020	Undefined		
X0021	Skip signal	Normally open contact	
X0022	Undefined		
X0023	Undefined		

X0024	External clamping/releasing tool control	Normally open contact	
X0025	Releasing tool check	Normally open contact	
X0026	Clamping tool check	Normally open contact	
X0027	Undefined		
X0030	Undefined		
X0031	Undefined		
X0032	Undefined		
X0033	Undefined		
X0034	Undefined		
X0035	Undefined		
X0036	Undefined		
X0037	Undefined		
X0040	Undefined		
X0041	Spindle gear-1 in-position	Normally open contact	
X0042	Spindle gear-2 in-position	Normally open contact	
X0043	Spindle gear-3 in-position	Normally open contact	
X0044	Undefined		
X0045	Undefined		
X0046	Spindle speed arrival	Normally closed contact	
X0047	Spindle zero speed arrival	Normally closed contact	
X0050	Spindle orientation in-position	Normally closed contact	
X0051	Tool magazine forward in-position	Determined by the paramter	
X0052	Tool magazine backward in-position	Determined by the paramter	
X0053	Tool magazine CCW/CW in-position	Determined by the paramter	
X0054	Tool magazine zero return in-position	Determined by the paramter	
X0055	Undefined		
X0056	Undefined		
X0057	Undefined		
X0060	External MPG X axis selection	Normally open contact	
X0061	External MPG Y axis selection	Normally open contact	
X0062	External MPG Z axis selection	Normally open contact	
X0063	External MPG A axis selection	Normally open contact	
X0064	External MPG step 0.001	Normally open contact	
X0065	External MPG step 0.01	Normally open contact	
X0066	External MPG step 0.1	Normally open contact	
X0067	External emergency stop	Normally closed contact	

Note:

- (1) Refer to **Volume Four** about PMC input (X) connection method.
- (2) Contact selection: normally open contact and normally closed contact. The contact is determined to be normally open or normmaly closed,
- (3) When the ladder is used, the user can add the new function for the undefined input.

Table 2 Output signal interface definition

Address	Definition	Remark
Y0000	Z axis holding brake	

GSK 广州数控 GSK218M CNC System Connection and PLC Manual

Y0001	Cooling	
Y0002	Tool releasing/clamping	
Y0003	Undefined	
Y0004	Spindel brake	
Y0005	Spindel impulse	
Y0006	Red alarm light	
Y0007	Yellow alarm light	
Y0010	Green alarm light	
Y0011	Chip removal control	
Y0012	Lubrication control	
Y0013	Machine light control	
Y0014	Undefined	
Y0015	Spindle blowing	
Y0016	Undefined	
Y0017	Undefined	
Y0020	Spindle enabling	
Y0021	Spindle orientation	
Y0022	Spindle CCW	
Y0023	Spindle CW	
Y0024	Undefined	
Y0025	Undefined	
Y0026	Undefined	
Y0027	Undefined	
Y0030	Tool magazine CCW	
Y0031	Tool magazine CW	
Y0032	Tool magazine forward	
Y0033	Tool magazine backward	
Y0034	Spindle gear 1(frequency conversion\IO point control)	
Y0035	Spindle gear 2(frequency conversion\IO point control)	
Y0036	Spindle gear 3(frequency conversion\IO point control)	
Y0037	Spindle gear 4(frequency conversion\IO point control))	
Y0040	Undefined	
Y0041	Undefined	
Y0042	Undefined	
Y0043	Undefined	
Y0044	Undefined	
Y0045	Undefined	
Y0046	Undefined	
Y0047	Undefined	
Y0050	Undefined	
Y0051	Undefined	
Y0052	Undefined	
Y0053	Undefined	
Y0054	Undefined	

Y0055	Undefined	
Y0056	Undefined	
Y0057	Undefined	

Note:

- (1) Refer to **Volume Four** about PMC input (X) connection method.
- (2) When the ladder is used, the user can add the new function for the undefined input.

Table 3 KAPA address definition

Address	Definition	Status 0	Status1	Setting value by customer
K0000	Permit PLC parameter to be modified	No permission	Permission	
K0001	Permit PLC signal to be debugged	No permission	Permission	
K0002	All Y signals are cleared after PLC enters the debugging mode.	Not clearing	Clearing	
K0003	Permit A address information to be edited	No permission	Permission	
K0004	Permit K address information to be edited	No permission	Permission	
K0005	Permit X address information to be modified	No permission	Permission	
K0006	Permit Y address information to be modified	No permission	Permission	
K0007	Permit the instruction table to be operated	No permission	Permission	
K0010	Permit the tool magazine to be used	No permission	Permission	
K0011	Reversed			
K0012	Reversed			
K0013	Reversed			
K0014	Reversed			
K0015	Reversed			
K0016	Reversed			
K0017	Reversed			
K0020	Reversed			
K0021	Reversed			
K0022	Reversed			
K0023	Reversed			
K0024	Reversed			
K0025	Reversed			

K0026	Reversed			
K0027	Reversed			
K0030	Reversed			
K0031	Reversed			
K0032	Reversed			
K0033	Reversed			
K0034	Reversed			
K0035	Reversed			
K0036	Reversed			
K0037	Reversed			
K0040	Whether the spindle uses the gear control(I/O point)	No	Yes	
K0041	If the manual reference point controls one axis	Many axes	1 axis	
K0042	Reversed			
K0043	Reversed			
K0044	Reversed			
K0045	Reversed			
K0046	Reversed			
K0047	Reversed			
K0050	Whether the machine tool has external handwheel(MPG)	No	Yes	
K0051	Whether the machine tool has external cycle Start function	No	Yes	
K0052	Whether the system enters the debugging mode	No	Yes	
K0053	Reversed			
K0054	Reversed			
K0055	Reversed			
K0056	Reversed			
K0057	Reversed			
K0060	X axis limit switch selection	2 PCS	1 PCS	
K0061	Y axis limit switch selection	2 PCS	1 PCS	
K0062	Z axis limit switch selection	2 PCS	1 PCS	
K0063	4TH axis limit switch selection	2 PCS	1 PCS	
K0064	Reversed			
K0065	Reversed			
K0066	Reversed			

K0067	Reversed			
K0070	X axis limit alarm reverse			
K0071	Y axis limit alarm reverse			
K0072	Z axis limit alarm reverse			
K0073	4TH axis limit alarm reverse			
K0074	Reversed			
K0075	Reversed			
K0076	Reversed			
K0077	Reversed			
K0080	Whether the 4 TH axis is used	No	Yes	
K0081	The tool clamping/releasing control selection	External button	Button on panel	
K0082	Whether the tool clamping/releasing device is used	Yes	No	
K0083	Whether the automatic lubricating control is used	Yes	No	
K0084	Reversed			
K0085	Reversed			
K0086	Reversed			
K0087	Reversed			
K0090	Reversed			
K0091	Reversed			
K0092	Reversed			
K0093	Reversed			
K0094	Reversed			
K0095	Reversed			
K0096	Reversed			
K0097	Reversed			
K0100	The tool magazine rotation in-position modeselection	No reaction	Reaction	
K0101	Whether the tool magazine has the zero switch	No	Yes	
K0102	The tool magazine zero return contact selection	Normal open	Normal close	
K0103	The tool magazine infeed tool contact selection	Normal open	Normal close	
K0104	The tool magazine tool retraction contact selection	Normal open	Normal close	
K0105	The tool counting switch contact selection	Normal	Normal	

		open	close	
K0106	Whether the tool origin point setting is enabled	Disabled	Enabled	
K0107	Whether the tool magazine enters the regulation mode	No	Yes	
K0110	Whether the manual tool clamping/releasing prompts the tool number which corresponds to the spindle	Yes	No	
K0111	Whether the manual operation returns the tool change position	No	Yes	
K0112	Reversed			
K0113	Reversed			
K0114	Reversed			
K0115	Reversed			
K0116	Reversed			
K0117	Reversed			

KAPA use notes:

1. When the system normally runs, K0000, K0001, K0002, K0003, K0004, K0005, K0006, K0007, K0052, K0107 must be 0, otherwise there may be the unexpected accident.
2. The modified K0010 is valid when the system is started agine, when K0010=0(i.e. the tool magazine is not used)
3. When K0010=1(i.e. the tool magazine is enabled), K0082 setting is disabled.
4. When K0082=0(i.e. the tool clamping/releasing device is used), K0081 setting is disabled.
5. K0060 setting:
 When two travel limit switches on X axis have been installed (the positive limit switch connects with X0.0, the negative limit switch connects with X 0.1) , K0060 set to 0 is enabled, and K0070 setting is disabled.
 When one travel limit switch on X axis is installed (connecting with X0.0) k0060 set to 1 is enabled,
 When the system alarms or X axis moves in the negative direction to the limit, the system alarms for the positive direction, when the K0080 is modified, the alarm reverses, namely, the error alarm is regulated.
 The settings ofK0061 and K0071 on Y axis, K0062 and K0072 on Z axis, K0063 and K0073 on the 4TH axis are the same that of X axis.
6. When K0083=0, the lubricating ON/OFF time is controlled by the system, i.e. by regulating CTR101(lubricating OFF time: default: minute) and CTR102(lubricating ON time: default: second), when K0083=1, the lubricating is not controlled by the system.
7. K0052=1, all alarm interlocks are released, and the system enters the debugging mode,

which is used when the system is being tested, when the system runs normally, the parameter is set to 0, otherwise, there may be an unexpected accident.

8. K0100, K0101, K0102, K0103, K0104, K0105, K0106, K0107, K0110, K0111

Table 4 PLC external alarm definition

PMC alarm number	A address	Alarm content
1200	A0000	Air pressure check abnormal
1201	A0001	Lubricating check abnormal
1202	A0002	Lubricating motor check abnormal
1203	A0003	Cooling motor check abnormal
1204	A0004	Chip removal motor check abnormal
1205	A0005	Pressure oil pump check abnormal
1206	A0006	Spindle cooling unit check abnormal
1207	A0007	Machine tool light check abnormal
1208	A0010	Machine tool control box
1209	A0011	Machine tool bed temperature check abnormal
1210	A0012	Machine tool vibration check abnormal
1211	A0013	Pressure oil temperature check abnormal
1212	A0014	Oil pressure low
1213	A0015	Machine not ready
1214	A0016	Reversed
1215	A0017	Reversed
1216	A0020	Do not rotate the spindle when the tool releases
1217	A0021	The tool cannot release when the spindle rotates
1218	A0022	Confirm the tool number when the tool magazine stops normally
1219	A0023	The spindle cannot rotate when the tool magazine is in the infeed tool position
1220	A0024	Spindle tool clamping abnormal
1221	A0025	Spindle tool releasing check abnormal

1222	A0026	Spindle unit temperature check abnormal
1223	A0027	Spindle speed check abnormal
1224	A0030	Spindle motor enabling check abnormal
1225	A0031	Spindle orientation in-position check abnormal
1226	A0032	Spindle gear change abnormal
1227	A0033	The tool magazine cannot rotate when it is not in the origin point
1228	A0034	The tool magazine cannot execute the cycle start in the infeed tool position
1229	A0035	Set spindle tool number
1230	A0036	The tool change cannot be executed when the spindle tool releases
1231	A0037	The tool change cannot be executed when the tool magazine is in the retraction position
1232	A0040	The tool magazine rotation in-position check abnormal
1233	A0041	When the tool magazine rotates, the motor check is abnormal
1234	A0042	The program stops run when the tool magazine is in the infeed position
1235	A0043	The tool magazine move in-position check abnormal
1236	A0044	The tool magazine zero return check abnormal
1237	A0045	It needs to execute the zero return when the tool magazine position lose
1238	A0046	The infeed in-position check abnormal
1239	A0047	The retraction in-position check abnormal
1240	A0050	The tool magazine executes the zero return because of the abnormal
1241	A0051	The tool magazine infeed check abnormal

1242	A0052	The tool magazine retraction check abnormal
1243	A0053	The tool magazine zero position setting is valid
1244	A0054	Stop the abnormal tool change
1245	A0055	There is no T number or there is the repetitive tool number
1246	A0056	The infeed tool cannot be executed because it is not in tool change position
1247	A0057	The tool magazine does not execute the infeed tool because the spindle does not perform the positioning
1248	A0060	The tool magazine does not execute the retraction when the tool is released
1249	A0061	The spindle with the tool does not execute the infeed tool
1250	A0062	The spindle and the current tool number of tool magazine does not execute the infeed tool
1251	A0063	Please cut off
1252	A0064	The tool clamps
1253	A0065	Debug the tool magazine carefully
1254	A0066	The system does not execute The cycle start when the tool magazine is in the debugging mode
1255	A0067	The clamped tool cannot return to the origin position
1256	A0070	The clamped tool cannot return to the tool change position
1257	A0071	The spindle cannot return to the tool exchange position
1258	A0072	The tool magazine cannot return to the tool change position
1259	A0073	Reversed
1260	A0074	The cycle start cannot be executed when returning to the tool change position is executed manually

1261	A0075	The retraction cannot be executed in the origin position
1262	A0076	Exceed the safety position
1263	A0077	The cycle start cannot be executed in the debugging mode

PLC alarm diagnosis:

Alarm information: 1200 the air pressure check is abnormal.

Fault cause: defined by customer

Troubleshooting: no

Alarm information: 1201 the lubricant check is abnormal.

Fault cause: defined by customer

Troubleshooting: no

Alarm information: 1202 the lubricating motor check is abnormal.

Fault cause: defined by customer

Troubleshooting: no

Alarm information: 1203 the cooling motor check is abnormal.

Fault cause: defined by customer

Troubleshooting: no

Alarm information: 1204 the chip removal check is abnormal.

Fault cause: defined by customer

Troubleshooting: no

Alarm information: 1205 the pressure oil pump motor check is abnormal.

Fault cause: defined by customer

Troubleshooting: no

Alarm information: 1206 the spindle cooling unit check is abnormal

Fault cause: defined by customer

Troubleshooting: no

Alarm information: 1207 the machine light check is abnormal.

Fault cause: defined by customer

Troubleshooting: no

Alarm information: 120 the machine control box temperature check is abnormal.

Fault cause: defined by customer

Troubleshooting: no

Alarm information: 1209 the machine bed temperature check is abnormal.

Fault cause: defined by customer

Troubleshooting: no

Alarm information: 1210 the machine vibration frequency check is abnormal.

Fault cause: defined by customer

Troubleshooting: no

Alarm information: 1211 pressure oil temperature check is abnormal.

Fault cause: defined by customer

Troubleshooting: no

Alarm information: 1212 the oil pressure is low.

Fault cause: defined by customer

Troubleshooting: no

Alarm information: 1213 the machine is not ready.

Fault cause: defined by customer

Troubleshooting: no

Alarm information: 1214 reserved

Fault cause:

Troubleshooting:

Alarm information: 1215 reversed

Fault cause:

Troubleshooting:

Alarm information: 1216 do not rotate the spindle when the tool releases.

Fault cause: execute the spindle rotating when the tool releases: in Manual mode, press the

spindle CCW, CW, JOG, POSITION, or execute M03, M04, M19 in AUTO mode, the spindle will rotate.

Troubleshooting: in Manual mode, press "CLAMP/RELEASE", and the tool is clamped (i.e. Y2=0) to check whether the tool clamp check switch is 1, when it is 1, the rotating spindle does not appear alarm.

Alarm information: 1217 the tool does not release when the spindle rotates.

Fault cause: the tool release instruction is executed when the spindle rotates.

Troubleshooting: when the spindle stops, the tool release instruction is executed to avoid the alarm.

Alarm information: 1218 confirm the tool number again because the tool magazine abnormally stops.

Fault cause: M6 is executed when the tool magazine rotates, the alarm appears, or press "RESET", the alarm appears.

Troubleshooting: 1. the tool magazine executes the zero return.
2. set the spindle tool number and tool magazine number again.

Alarm information: 1219 the spindle cannot rotate when the tool magazine is in the infeed position

Fault cause: the spindle rotation is executed when the tool magazine does not retract to the in-position.

Troubleshooting: execute the tool magazine returning to the retraction position (whether the tool magazine has returned to the retraction position by X5.2).

Alarm information: 1220 the clamped tool corresponding to the spindle is abnormal.

Fault cause: when the tool is clamped (i.e. Y0.2=0), the tool magazine clamp check switch (X2.6) is not closed during the time set by T010.

Troubleshooting: 1. check whether the tool magazine clamp check switch is normal.
2. check whether Y0.2 outputs.
3. regulate again T010 time.

Alarm information: 1221 the released tool corresponding to the spindle is abnormal.

Fault cause: when the tool is clamped (i.e. Y0.2=1), the tool magazine clamp check switch (X2.5) is not closed during the time set by T009.

Troubleshooting: 1. check whether the tool magazine release check switch is normal.
2. check whether Y0.2 outputs.

3. regulate again T009 time.

Alarm information: 1222 the spindle unit temperature check is abnormal

Fault cause: defined by customer

Troubleshooting: no

Alarm information: 1223 the spindle speed is abnormal

Fault cause: defined by customer

Troubleshooting: no

Alarm information: 1224 the spindle motor enabling check is abnormal.

Fault cause: defined by customer

Troubleshooting: no

Alarm information: 1224 the spindle motor enabling check is abnormal.

Fault cause: when the tool is clamped(i.e.Y2.1=1), the tool magazine clamp check switch (X2.5) is not closed during the time set by T013.

Troubleshooting: 1. the spindle driver or spindle encoder is normal.

2. check whether Y2.1 outputs.

3. regulate again T013 time.

Alarm information: 1226 the spindle gear change is abnormal

Fault cause: defined by customer

Troubleshooting: no

Alarm information: 1227 the tool magazine which is not in the origin point cannot rotate.

Fault cause: the tool magazine is not in the retraction position and Z axis is not in the origin point, or press "MAG. CCW" or "MAG. CW", the alarm appears.

Troubleshooting: the tool magazine returns the retraction position or Z axis returns to the origin point.

Alarm information: 1228 the tool magazine cannot execute the cycle start when it is in the infeed position

Fault cause: when the tool magazine is not in the retraction position, or press "CYCLE START", the alarm appears.

Troubleshooting: the tool magazine returns the retraction position

Alarm information: 1229 please set the spindle tool number

Fault cause: press "CLAMP/RELEASE" when the tool number is 0, which causes the alarm appears.

Troubleshooting: the alarm only prompts the tool cannot be installed on the spindle but KAPA0110 is modified to shield the alarm when the tool number is 0

Alarm information: 1230 the tool change cannot be executed when the spindle tool is released.

Fault cause: when the tool is released(Y0.2=1), M06 or M50 is executed.

Troubleshooting: ensure that the spindle is clamped(Y0.2=0).

Alarm information: 1231 the tool change cannot be executed when the tool magazine is not in the retraction position.

Fault cause: Execute M06 or M50 when the tool magazine is not in the retraction position.

Troubleshooting: ensure that the spindle is clamped

Alarm information: 1232 the tool magazine rotating in-position check is abnormal

Fault cause: defined by customer

Troubleshooting: no

Alarm information: 1233 the motor check is abnormal when the tool magazine rotates

Fault cause: defined by customer

Troubleshooting: no

Alarm information: 1234 the program stops the run when the tool magazine is in the infeed position.

Fault cause: when the program is running, the tool is not in the retraction position, which causes the alarm appears.

Troubleshooting: the program is executed when the tool magazine is in the retraction position.

Alarm information: 1235 the tool magazine moving in-position check is abnormal

Fault cause: reserved

Troubleshooting:

Alarm information: 1236 the tool magazine zero return check is abnormal

Fault cause: reserved

Troubleshooting:

Alarm information: 1237 the tool magazine needs to return to zero because its origin is lost.

Fault cause:

Troubleshooting:

Alarm information: 1238 the infeed in-position check is abnormal

Fault cause: Reversed

Troubleshooting: Reversed

Alarm information: 1239 the retraction in-position check is abnormal.

Fault cause: Reversed

Troubleshooting: Reversed

Alarm information: 1240 the tool magazine needs to return the zero again because it is abnormal.

Fault cause: 1. the tool magazine stops the rotation in the time set by T102, the system has checked that the tool magazine count switch (X5.3) abnormally creates the pulse signal.

2. when the tool magazine rotates, the system checks that the tool magazine count switch 0 or 1 exceeds the time set by T103.

Troubleshooting: 1. the tool magazine CCW or CW output (Y3.0 Y3.1) is abnormal.

2. the tool magazine count switch is abnormal.

3. set T102 T103 value again.

Alarm information: 1241 the tool magazine infeed check is abnormal

Fault cause: when the tool magazine executes the infeed (i.e. Y3.2=1), the tool magazine infeed check switch (X5.1) has no operation.

Troubleshooting: 1. check whether the tool magazine infeed check switch is normal.

Alarm information: 1242 the tool magazine retraction check is abnormal

Fault cause: the tool magazine executes the retraction in the time set by T105, the tool magazine infeed check switch (X5.2) has no operation.

Troubleshooting: 1. check whether the tool magazine infeed check switch is normal.

2. check whether Y3.3 outputs.

3. regulate again T105 time

Alarm information: 1243 the tool magazine zero setting is enabled.

Fault cause: when the tool magazine has no zero return switch (i.e. K0101=0), and K0106=1, the system alarms and prompts the tool magazine zero setting is enabled.

Troubleshooting: set K0106 to 0.

Alarm information: 1244 the tool change is stopped because of its abnormal run

Fault cause: when the tool magazine executes automatically the tool change, the tool change stops because of its abnormal run, which causes the system alarms and prompts there may be the disorder of tool magazine and the spindle tool number

Troubleshooting: press "RESET" to clear the alarm.

Alarm information: 1245 there is T tool number or repeated tool number in the tool list.

Fault cause: there is no tool number specified by T code or there is the repeated tool number specified by T code in the tool list (D001-D099).

Troubleshooting: modify the value in the tool list.

Alarm information: 1246 the tool magazine cannot execute the tool change because it is not in the tool change position.

Fault cause: Z axis is not the tool change position, and the tool magazine infeed is executed.

Troubleshooting: execute G91G30Z0 to make Z axis return to the tool change position.

Alarm information: 1247 the tool magazine cannot execute the infeed because the spindle does not position.

Fault cause: the spindle does not position and the tool magazine infeed is executed.

Troubleshooting: position the spindle.

Alarm information: 1248 the tool magazine does not execute the retraction when the tool is released.

Fault cause: the retraction is executed when the spindle tool is released.

Troubleshooting: execute the retraction after the spindle tool is clamped.

Alarm information: 1249 the spindle with the tool cannot execute the infeed.

Fault cause: the infeed is executed when Z axis is in the origin and the spindle has the tool.(D245 is not 0)

Troubleshooting: dismount the tool on the spindle and set D245 to 0.

Alarm information: 1250 the infeed cannot be executed because the tool number on the spindle is not the same that of the current tool magazine.

Fault cause: Z axis is in the tool change position, and the infeed is executed when the tool number on the spindle is not the same that of the current tool magazine.

Troubleshooting: rotate the tool magazine to ensure the tool number on the spindle is the same that of current tool magazine.

Alarm information: 1251 please turn off the power supply

Fault cause: the modified parameter is enabled after power-off.

Troubleshooting: start the system again.

Alarm information: 1252 Z axis cannot move because the tool is clamped.

Fault cause: when the tool is in the infeed position and the spindle tool is clamped, Z axis moves.

Troubleshooting: 1. the tool magazine is in the retraction position.
2. the spindle tool is released.

Alarm information: 1253 carefully operate the system because the tool magazine is in the debug mode.

Fault cause: When K0107 is set to 1, the system alarms, which prompts the tool magazine enters the debug mode, and which is not related to its other alarms and interlock signal, at this time, we should carefully operate the system, otherwise, there maybe damage the machiney.

Troubleshooting: press "RESET".

Alarm information: 1254 the system cannot execute the cycle start

Fault cause: when K0107 is set to 1, the "CYCLE START" is pressed in AUTO or MDI or DNC mode, which causes the system alarms.

Troubleshooting: set K0107 to 0.

Alarm information: 1255 the tool cannot return to the orgin point because it is clamped.

Fault cause: Z axis is executed to return to the origin point when the tool magazine is in the infeed position and the spindle tool is clamped.

Troubleshooting: 1. the tool magazine is in the retraction position.
2. the spindle tool is released.

Alarm information: 1256 the tool cannot return the tool change position because it is clamped.

Fault cause: Z axis is executed to return to the tool change position when the tool magazine is in the infeed position and the spindle tool is clamped.

Troubleshooting: 1. the tool magazine is in the retraction position.
2. the spindle tool is released.

Alarm information: 1257 the spindle cannot return the tool chan

Fault cause: Z axis is executed to return to the tool change position when the tool magazine is in the infeed position and the spindle is not positioned.

Troubleshooting: 1. the tool magazine is in the retraction position.
2. the spindle tool is released.

Alarm information: 1258 the tool magazine cannot return to the tool change position because it is abnormal.

Fault cause: reserved

Troubleshooting: no

Alarm information: 1259 reversed

Fault cause:

Troubleshooting:

Alarm information: 1260 the system cannot execute the cycle start because the manual tool change is executed.

Fault cause: when K0111 is set to 1(i.e. the manual tool change position return is enabled), the “CYCLE START” is pressed in AUTO or MDI or DNC mode, which causes the system alarms.

Troubleshooting: set K0111 to 0.

Alarm information: 1261 the tool cannot execute the retraction because it is not in the origin point.

Fault cause: the tool magazine retraction is executed when the tool magazine is in the infeed position and Z axis is not in the origin point.

Troubleshooting: the retraction is executed after Z axis returns to the origin point.

Alarm information: 1262 exceed the safety position.

Fault cause: Z axis exceeds the tool change position when the tool magazine is in the infeed position and Z axis moves.

Troubleshooting: move Z axis to the position between the tool change position and origin point.

Alarm information: 1263 the system cannot execute the cycle start when it is in the debug mode.

Fault cause: reserved

Troubleshooting: reserved

Table 5 TMR parameter definition

Address	Statement	Initial value (ms)	Setting value by customer (ms)
T0001	Delay timer for spindle CCW completion	500	
T0002	Delay timer for spindle CW completion	500	
T0003	Delay timer for spindle gear change completion	500	
T0004	Delay timer for spindle positioning completion	0	
T0005	Delay timer for auxiliary function(M.S.T) completion	0	
T0006	Timer for spindle gear change check	500	
T0007	Delay timer for spindle tool release completion	0	
T0008	Delay timer for spindle tool clamp completion	0	
T0009	Time setting for spindle tool release check	8000	
T0010	Time setting for spindle tool clamp check	8000	
T0011	Pulse signal time 1 in 1 second	500	
T0012	Pulse signal time 2 in 1 second	500	
T0013	Time setting for spindle positioning check time	8000	
T0014	Time setting for spindle CCW check	500	
T0015	Time setting for spindle CW check	500	
T0016	Time unit setting for lubricating	60000	
T0017	Time unit setting for lubricating	1000	
T0018	Time setting for spindle positioning delay check	2000	
T0019	Delay timer for spindle JOG	2000	
T0100	Delay time 1 for turret tool magazine manually rotating	2000	
T0101	Delay time 2 for turret tool magazine manually rotating	2000	
T0102	Delay check time setting for turret tool magazine stopping	2000	
T0103	Delay check time setting for turret tool magazine rotating	3000	
T0104	Delay check time setting for tool magazine infeed	10000	
T0105	Delay check time setting for turret tool magazine retraction	10000	
T0106	Delay timer for turret tool magazine infeed completion	0	
T0107	Delay timer for turret tool magazine retraction completion	0	

Notes:

1. PLC pulse signal period is 1s, set T0011 and T0012 to 500.
2. T016 setting will change C101 unit. For example: C101 unit is 600000ms(i.e. 1m) when T0016 is set to 60000.
3. T017 setting will change C102 unit. For example: C102 unit is 10000ms(i.e. 1s) when T0017 is set to 10000.

Table 6 DATA parameter definition

Definition	Statement	Setting value by customer
D000	Spindle tool number display	Cannot set
D001	No.1 tool number	
D002	No.2 tool number	
⋮	⋮	
D098	No.98 tool number	
D099	No.99 tool number	
D100	Tool magazine capacity	
D241	T code tool number	Cannot set
D243	Current tool magazine number	Cannot set
D245	Spindle tool number	

Notes:

1. D100 setting value must be less than 100, and must be the same that of CTR100, otherwise, there may be the abnormal.
For example: D100=16, the data table D001-D016 is enabled.
D100=24, the data table D001-D024 is enabled.
2. D000 only displays the spindle tool number, the spindle tool number cannot be modified at the D000 but at the D245.
3. D241 value cannot be modified.
4. See Chapter 3 about the detailed.

Table 7 CTR parameter definition

Address	Statement	Initial value	Setting value by cusotmer
---------	-----------	---------------	---------------------------

C100	Tool magazine capacity setting	16	
C101	Automatic lubricating OFFtime setting	30	
C102	Automatic lubricating ON time setting	30	

Notes:

1. CTR100 setting value must be less than 100 and must be the same that of D100, otherwise there may be the abnormal.

For example: CTR100 =16, the total tool magazine number is 16.

CTR100=24, the total tool magazine number is 24.

2. C101 unit is related to T0016.

For example: T0016 is set to 60000, C101 unit is 1m, and C101 is set to 30, the lubricating OFF time is 30ms(minutes).

3. C102 unit is related to T0017

For example: T0017 is set to 1000, C102 unit is 1s, and C102 is set to 10, the lubricating OFF time is 10s.

Table 8 M code definition

M code	F signal	Function	Remark
M00	F0317	Program pause	
M01	F0304	Selection stop	
M02	F0305	End of program	
M03	F0300	Spindle CCW	
M04	F0301	Spindle CW	
M05	F0302	Spindle stop	
M06	F0303	Automatic tool change	
M08	F0310	Cooling ON	
M09	F0311	Cooling OFF	
M10	F0312	A axis clamp	Reversed
M11	F0313	A axis release	Reversed
M16	F0260	Spindle release instruction	Reversed
M17	F0261	Spindle clamp instruction	Reversed
M18	F-001	Cancel the spindle exact stop	
M19	F0262	Spindle exact stop	
M21	F0263	Search tool instruction when retraction	
M22	F0264	Search tool instruction when startup the current tool	
M23	F0265	Tool magazine forward	
M24	F0266	Tool magazine backward	
M26	F-001	Start chip removal lift conveyor	
M27	F-001	Close chip removal lift conveyor	

M29	F0322	Rigid tapping instruction	
M30	F0280	End of program	
M32	F0314	Lubricating ON	
M33	F0315	Lubricating OFF	
M35	F-001	Start spiral chip removal conveyor	
M36	F-001	Close spiral chip removal conveyor	
M40	F-001	X axis image	
M41	F-001	Y axis image	
M42	F-001	Z axis image	
M43	F-001	Cancel image	
M44	F0267	Start spindle blow	
M45	F0270	Stop spindle blow	
M50	F0271	Start automatic tool change	
M51	F0272	End of automatic tool change	
M53	F0273	Judge whether the tool is correct after the tool change is executed	Reversed
M55	F0274	Judge whether the spindle has the tool	Reversed

3. Usage and maintenance of GSK 218M CNC System matching with turret tool magazine

Tool magazine preparation and use

1. Tool magazine installation and related PLC parameter setting

Operation aim: ensure the ladder fit to the allocation of tool magazine

A. requirements of the ladder matched with the turret tool magazine to the machine tool:

1. The machine tool has the spindle tool automatically clamping/releasing device which has the normally open in-position check switch.
2. The spindle has the positioning function and its positioning angle can be regulated.
3. The tool magazine capacity must be less than 100.
4. The tool magazine can execute CCW/CW.
5. The tool magazine has the count switch, forward in-position check switch, and retraction in-position check switch.
6. The tool magazine has zero return switch(selection).

B. Wire connection related to tool magazine

1) Input .

Address	Statement	Remark
X0024	External clamp/release control	Selection
X0025	Release check	Normally open contact
X0026	Clamp check	Normally open contact
X0050	Spindle orientation in-position	Normally-closed

		contact
X0051	Tool magazine forward in-position	Normal open or normal close
X0052	Tool magazine backward in-position	Normal open or normal close
X0053	Tool magazine CCW/CW in-position	Normal open or normal close
X0054	Tool magazine zero return in-position	Selection

2) . Output:

Address	Statement	Remark
Y0002	Tool release/clamp	
Y0020	Spindle enabling	
Y0021	Spindle orientation	
Y0030	Tool magazine CCW	
Y0031	Tool magazine CW	
Y0032	Tool magazine forward	
Y0033	Tool magazine backward	

C. Tool magazine switch type and rotation in-position mode selection

- Tool magazine no zero return switch set K0101 to 0
- Tool magazine zero return switch set K101 to 1
- Tool magazine zero return switch is normal open set K0102 to 0
- Tool magazine zero return switch is normal close set K0102 to 1
- Tool magazine infeed switch is normal open set K0103 to 0
- Tool magazine infeed switch is normal close set K0103 to 1
- Tool magazine retraction switch is normal open set K0104 to 0
- Tool magazine retraction switch is normal close set K0104 to 1
- Tool magazine count switch is normal open set K0105 to 0
- Tool magazine count switch is close open set K0105 to 1
- Tool magazine rotation in-position A mode set K0100 to 0
- Tool magazine rotation in-position B mode set K0100 to 1

Note:

1. K0102 setting is disabled when K0101 is set to 0.
2. The tool magazine rotation in-position A mode: when the tool magazine rotates the normal stop position, the tool magazine count switch has not responded the block(See Fig. A).
3. The tool magazine rotation in-position A mode: when the tool magazine rotates

the normal stop position, the tool magazine count switch has responded the block(See Fig. B).

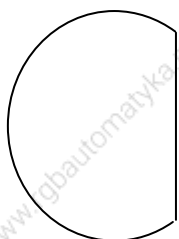

Fig. A

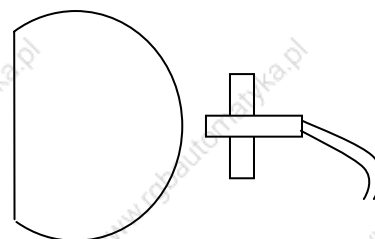
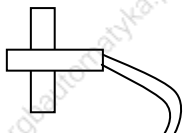

Fig. B

K0101=0 K0102=0 K0103=0 K0104=0 K0105=0 K0100=0

For example: the tool magazine has no zero return switch, all check switches are normal open and the rotation in-position is A mode, the parameter setting is as follows:

K0101=0 K0102=0 K0103=0 K0104=0 K0105=0 K0100=0

D. tool magazine capacity setting

Input tool magazine capacity in DATA100 and CTR100

Notes:

1. The tool magazine capacity is defined that total tool magazine numbers in the tool magazine.
2. DATA100 and CTR100 setting values must be less than 100.

E. Tool number setting:

Data talbe D001-D099 separately correspond to the tool magazine number 1-99, and the setting values in the data table D001-D009 separately corresponds to the tool number in the tool magazine number 1-99. D245 is the spindle tool number.

Notes:

1. In D001-D099, there is no the same tool number(except for 0), otherwise the system alarms when the tool change is executed.
2. The tool number setting range meets the requirements set by the parameter 0206, otherwise the system alarm when the T instruction is executed.

For example:when the tool magazine capacity is 16:

When the tool magazine is set orderly to 1-16 in D1-D16, and T8M6 is executed, the tool change is executed after No. 8 tool magazine number will rotate to the tool change position.

When the tool magazine is set orderly to 10, 20, 30...160 in D1-D16, and T80M6 is executed, the tool change is executed after No. 8 tool magazine number will rotate to the tool change position

When D1 and D2 are set to 8, and T8M6 is executed, the system alarms.

F. Time parameter setting related to the tool magazine:

Address	Statement	Setting range	Initial value (ms)
T0004	Delay timer for spindle positioning	More than or less than 0	0
T0007	Delay timer for spindle tool releasing completion	More than or equal to 0	0
T0008	Delay timer for spindle tool clamping completion	More than or equal to 0	0
T0009	Time setting for spindle tool releasing check	More than releasing tool time	8000
T0010	Time setting for spindle tool clamping check	More than clamping tool time	8000
T0013	Time setting for spindle positioning check	More than positioning time	8000
T0018	Time setting for spindle positioning delay check	Related to the positioning width	2000
T0100	Delay time 1 for turret tool magazine manually roating	More than rotating one tool selection	2000
T0101	Delay time 2 for turret tool magazine manually roating	More than rotating one tool selection	2000
T0102	Delay check time for turret tool magazine stopping	More than rotating one tool selection	2000
T0103	Delay check time for tool magazine rotating	More than rotating one tool selection	3000
T0104	Delay check time for turret tool magazine infeed	More than infeed time	10000
T0105	Delay check time for turret tool magazine retracting	More than retraction time	10000
T0106	Delay timer for turret tool magazine infeed completion	More than or equal to 0	0
T0107	Delay timer for turret tool magazine retraction completion	More than or equal to 0	0

Notes:

1. The above parameter(TMR) is related to the tool magazine type, the tool magazine speed and other performances. Please refer to the tool magazine performance to properly set the parameter.
2. when the above parameter (TMR) setting is not proper, the system alams to cause that the tool change is not executed normally.

The ladder match with the tool magazine after the above A-F steps are operated, but the tool magazine cannot normally run, the tool magazine executes the CCW, CW, infeed and retraction in Manual mode to check whether each operation of tool magazine is normal

through the following No. 2 setting and operation(i.e. 2. Tool magazine manual and zero return operation).

1. Tool magazine manual and zero return operation

Operation aim: check whether the each operation of tool magazine is normal.

The detailed operation is as follows:

A. the tool magazine is enabled.

1. Because the tool magazine is turret, and the following bit parameter must be set.

Bit parameter 53.0=1 bit parameter 53.1=0 bit parameter 53.2=0 bit parameter 53.3=0

B. Confirming the rotation direction of tool magazine

In Manual mode, press “MAG. CCW” and the tool magazine rotates according to the prescribed positive direction of machine tool, press “MAG. CW” and the tool magazine rotates according to the prescribed negative direction of machine tool, otherwise, the tool magazine count will be disorder to cause that the tool change is executed wrongly, which can be resolved by regulating the phase sequence of the motor.

C. Tool magazine zero return:

Tool magazine zero return operation is divided into zero return switch and no zero return switch.

1. The tool magazine has the zero return switch: press “MAG. ZERO” in “ZERO RETURN” mode, and the zero return is completed when the indicator is light(the light flashing indicates the tool magazine is executing the zero return.)

2. The tool magazine has no the zero return switch

a. In Manual mode, press “CCW” or “CW” to make the No. tool magazine number rotate to the tool change position.

b. set K0106 to 1 in MDI mode.

c. press “MAG. ZERO” in zero return mode until its indicator is light.

3. Spindle positioning angle and tool change coordinate position regulation

a. the spindle positioning angle regulation refers to the explanation of spindle driver.

b. Z axis has two positions including origin point and tool change position when the tool magazine executes the tool change.

The parameter 0047 must be set to 0 when the tool magazine returns to the origin point, otherwise, there maybe the accident to damage the machine.

We can correctly execute the tool change through the aboved 3 operations. Operating T and M instructions are as follows:

TxxM6; it has the same execution effect that of Txx;M6;

T0M6; the spindle tool retracts to the tool magazine.

Warning: the tool must not be installed on the spindle when the spindle tool number is 0, otherwise, there maybe the accident when the tool change is executed to damage the machine.

4. Macro program statement of GSK218M CNC System matching with turret tool magazine

Macro program statement of GSK218M CNC System matching with turret tool magazine

O91001; (program name)

G65 H81 P50 Q#1003 R1; (M.S.T and machine are locked, execute N50, end of program)

G69 G50 G15 G80; (cancel the related modes)

M50; (start the tool change and check its conditions of tool change, if not, the system alarms.)

G65 H81 P40 Q#1001 R1; (spindle tool number=T tool number: not execute the tool change but N40, end of program)

G65 H81 P20 Q#1000 R1; (spindle tool number=0: the spindle has no tool, execute N20 instead of the retraction tool instruction)

M19 G91 G30 Z0; (spindle positioning, return to the coordinat position of tool change)

M21; (retraction-> tool magazine rotating tool magazine forward spindle releasing)

N20 M19 G91 G28 Z0; (return to machine's origin point)

G65 H81 P30 Q#1002 R1; (T code tool number=0: not execute the tool search but N30)

M22; (tool search ->tool magazine rotating tool magazine forward spindle releasing tool)

G91 G30 Z0; (return to coordinate point of tool change)

N30 M17; (spindle clamping tool)

M24; (tool magazine retraction)

N40 M51; (end of tool change)

N50 M99; (end of program)

广州数控设备有限公司
GSK CNC EQUIPMENT CO., LTD.

Add: No.52, 1st . Street, Luochong North Road, Luochongwei, Guangzhou, 510165, China

Website: <http://www.gsk.com.cn>

Tel: 86-20-81796410/81797922

E-mail: gsk@gsk.com.cn

Fax: 86-20-81993683

All specifications and designs are subject to change without notice July 2007/Edition 2

Aug. 2007/Printing 2