

2. Specifications

Characteristic	Item	Specifications		
		1 Form A	1 Form C	
Contact	Arrangement			
	Contact resistance (Initial)	Max. 100 mΩ (AgNi type), Max. 30 mΩ (AgNi type/Au-plated) (By voltage drop 6 V DC 1A)		
	Contact material	AgNi type, AgNi type/Au-plated		
Rating	Nominal switching capacity (resistive load)	6 A 250 V AC		
	Max. switching power (resistive load)	1,500 VA		
	Max. switching voltage	250V AC		
	Max. switching current	6 A (AC)		
	Min. switching capacity (Reference value)*1	100 mA 5 V DC (AgNi type), 1 mA 1 V DC (AgNi type/Au-plated)		
Electrical characteristics	Insulation resistance (Initial)	Min. 1,000MΩ (at 500V DC) Measurement at same location as "Breakdown voltage" section.		
	Breakdown voltage (Initial)	Between open contacts	1,000 Vrms for 1 min. (Detection current: 10 mA)	
		Between contact and coil	4,000 Vrms for 1 min. (Detection current: 10 mA)	
	Surge breakdown voltage*2 (Between contact and coil) (Initial)	6,000 V		
	Operate time (at 20°C 68°F)	Max. 8 ms (Nominal coil voltage applied to the coil, excluding contact bounce time.)		
	Release time (at 20°C 68°F)	Max. 4 ms (Nominal coil voltage applied to the coil, excluding contact bounce time.) (without diode)		
Mechanical characteristics	Shock resistance	Functional	Min. 98 m/s ² (Half-wave pulse of sine wave: 11 ms; detection time: 10μs)	
		Destructive	Min. 980 m/s ² (Half-wave pulse of sine wave: 11 ms.)	
	Vibration resistance	Functional	10 to 55 Hz at double amplitude of 1 mm (Detection time: 10μs.)	
		Destructive	10 to 55 Hz at double amplitude of 1.5 mm	
Expected life	Mechanical	Min. 5×10 ⁶ (at 180 times/min.)		
Conditions	Conditions for operation, transport and storage*3	Ambient temperature: -40°C to +85°C -40°F to +185°F; Humidity: 5 to 85% R.H. (Not freezing and condensing at low temperature)		
Unit weight		Approx. 5 g .18 oz		

Notes: *1. This value can change due to the switching frequency, environmental conditions, and desired reliability level, therefore it is recommended to check this with the actual load.

*2. Wave is standard shock voltage of ±1.2×50μs according to JEC-212-1981

*3. The upper operation ambient temperature limit is the maximum temperature that can satisfy the coil temperature rise value. Refer to "Usage, transport and storage conditions" in NOTES.

3. Electrical life

Condition: Resistive load, at 6 times/min.

Type		Switching capacity	No. of operations
1 Form A		6A 250V AC	min. 5×10 ⁴
1 Form C	N.O.	6A 250V AC	min. 5×10 ⁴
	N.C.		min. 3×10 ⁴

REFERENCE DATA

1. Electrical life

Tested sample: APF30224

Load type		Voltage	Current	Ambient temperature	No. of ops.
Resistive load		250V AC	6 A	85°C 185°F	30,000
Inductive load	AC15	250V AC	3 A	25°C 77°F	20,000
	DC13	24V DC	2 A	25°C 77°F	6,000

Notes: 1. Switch contacts are all on N.O. side.

2. AC15 and DC13 comply with IEC-60947-5-1 testing conditions.

2. Max. switching capacity

Tested sample: APF30224

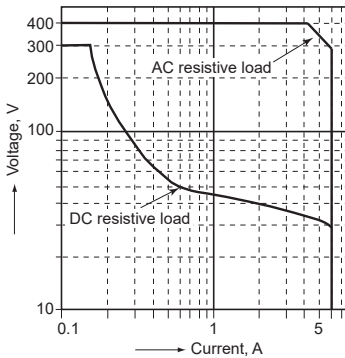

3. Coil temperature rise

Tested sample: APF30224

Measured portion: Inside the coil

Ambient temperature: 28°C 82°F

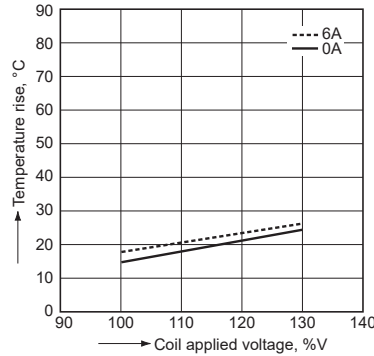

4. Ambient temperature characteristics

Tested sample: APF30224, 6 pcs.

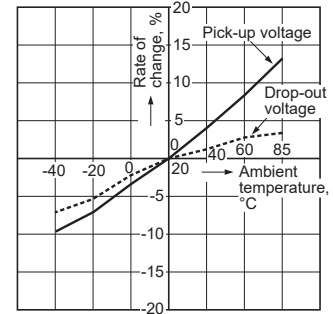

DIMENSIONS (mm inch)

1. 1 Form A type

CAD The CAD data of the products with a "CAD" mark can be downloaded from our Website.

CAD

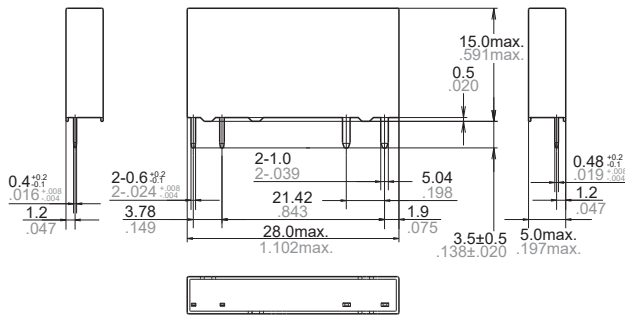

General tolerance: $\pm 0.3 \pm 0.12$

PC board pattern (Bottom view)

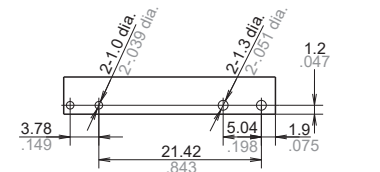

Tolerance: $\pm 0.1 \pm 0.04$

Schematic (Bottom view)



2. 1 Form C type

CAD

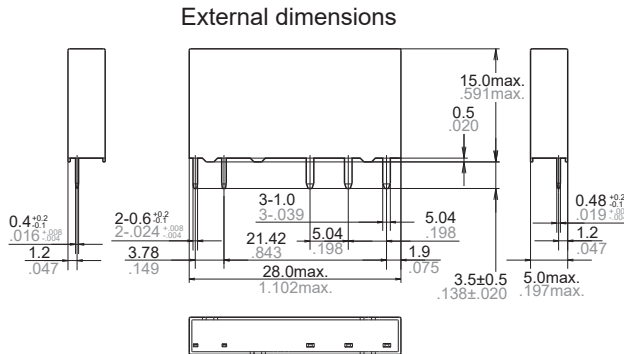

General tolerance: $\pm 0.3 \pm 0.12$

PC board pattern (Bottom view)

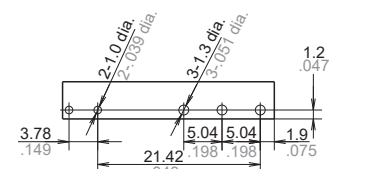

Tolerance: $\pm 0.1 \pm 0.04$

Schematic (Bottom view)

