



Photoelectric switches WLL 170(T), fibre-optic cables LL 3: flexible solutions with fibre-optic cable systems

	Photoelectric switches with fibre-optic cable
Proximity mode	
	Photoelectric switches with fibre-optic cable
Through-beam mode	

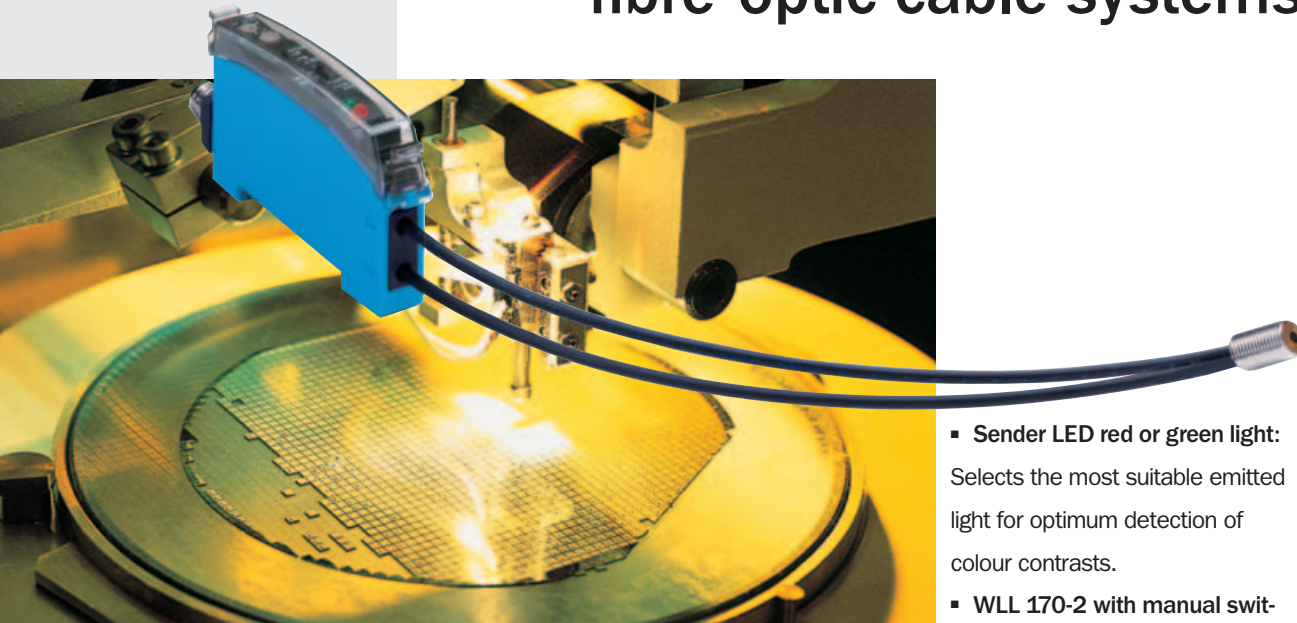

- **Sender LED red or green light:** Selects the most suitable emitted light for optimum detection of colour contrasts.

- **WLL 170-2 with manual switching threshold adjustment:**

The cost-effective solution for all standard applications.

- **WLL 170 High Speed:** 10,000 switching operations per second - the optimum for high speed applications.

- **WLL 170A with analogue output:** For easy measurement and control.

Large selection of suitable fibre-optic cables: Fibre-optic cable range LL 3. For WLL 170, there are around 90 LL 3 versions, offering maximum flexibility and choice for your requirements.

Typical uses for these WLL 170 / LL 3 fibre-optic cable combinations: semiconductor industry, electronics assembly, packaging technology, handling and assembly systems, special-purpose machinery, construction and precision engineering.

Fibre-optic sensors without baggage. Safe and simple switching:

The combination of photoelectric switches WLL 170(T) and fibre-optic cables LL 3 offers extremely simple handling and intelligent system options for a wide range of applications. For standard applications, but also for demanding applications such as detection of very small objects, recognition of colour marks or transparent materials.

You choose:

Suitable WLL 170(T) versions, optimised for various typical uses, are available

- **WLL 170T with teach-in:**

This teach-in version simplifies handling: the switching threshold and switching hysteresis are automatically set, via a push button (Teach-in).

► In pick-and-place systems, WLL 170(T) photoelectric switches with LL 3 plastic fibre-optic cables are used in a wide variety of configurations to monitor the presence or position of minute objects.

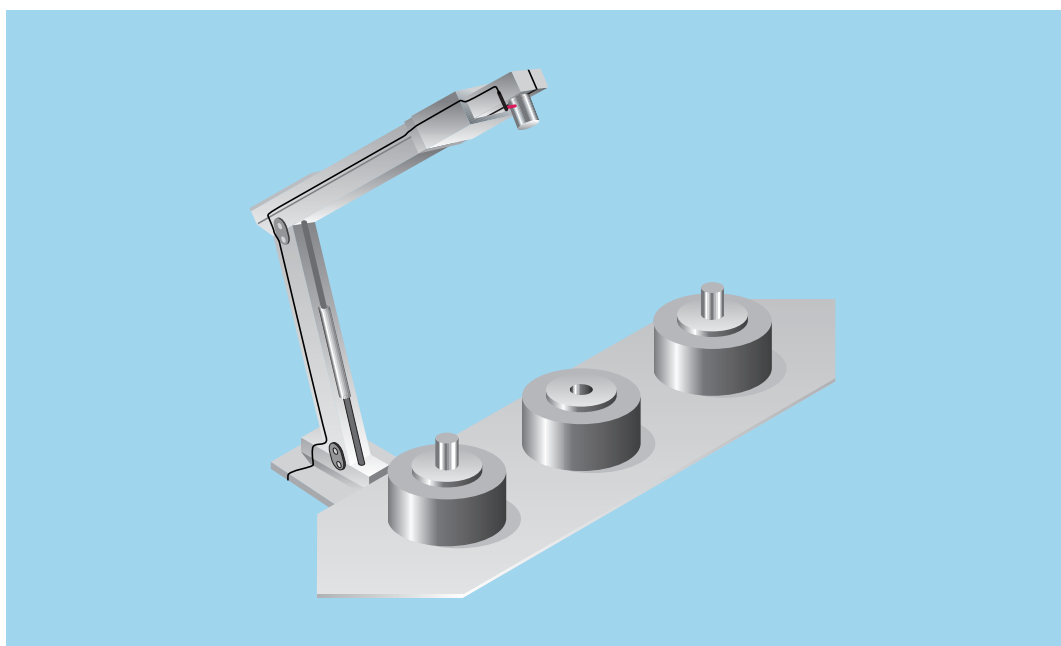

▼ Fibre-optic cables are widely used in the electronics industry. For example, fibre-optic cables with integrated 90° angle used for detecting contact pins in locations where space is restricted.

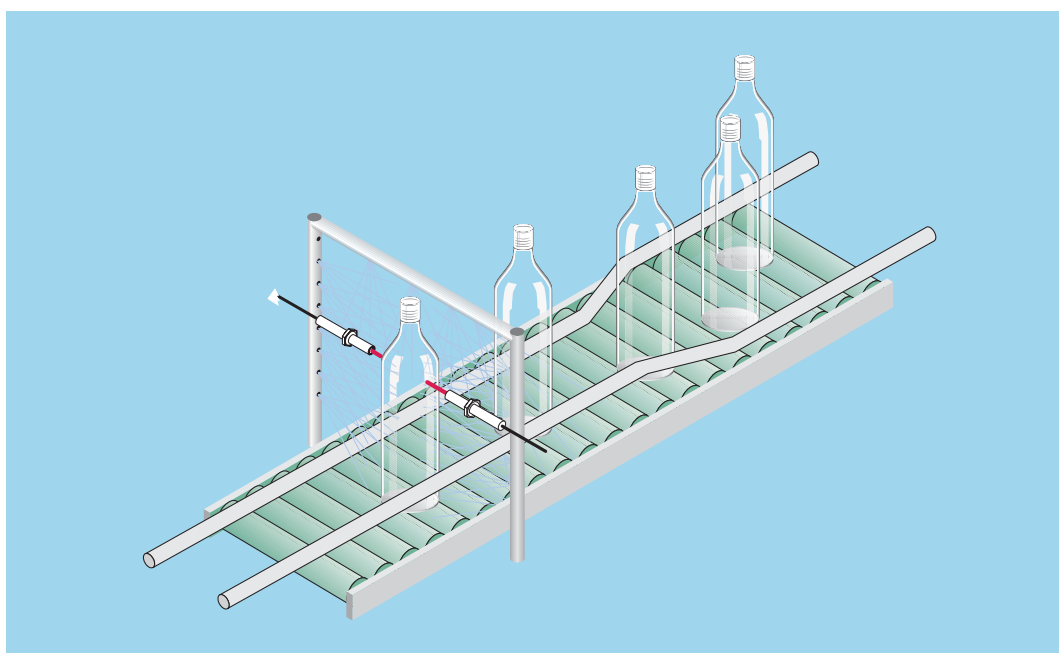
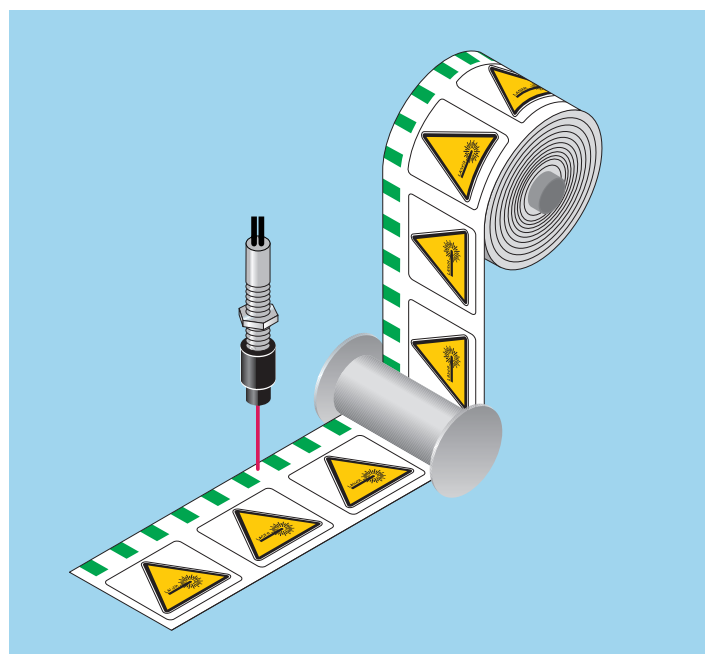
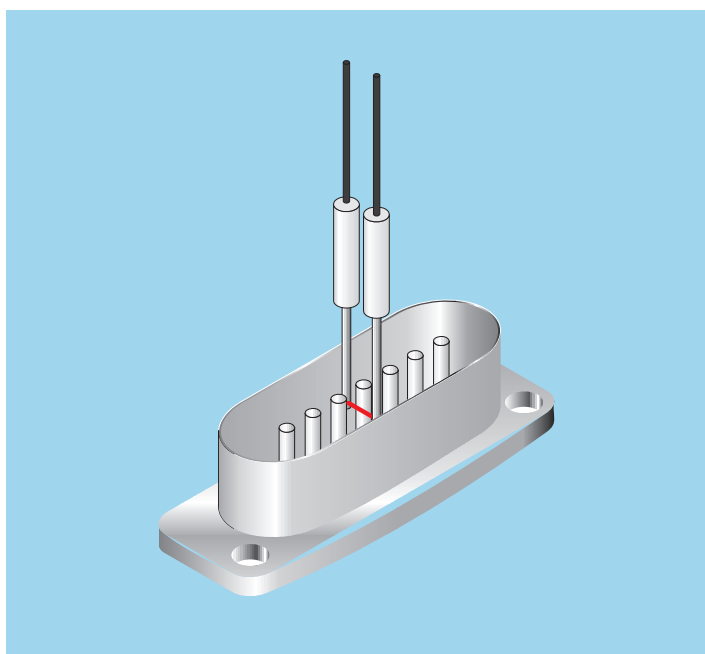

▲ WLL 170(T) units with red or green transmission light and LL 3 plastic fibre-optic cables for detecting print marks used to control labelling machines.

◀ LL 3 fibre-optic cables for special applications: here LL 3 cables with Teflon jacket are the right choice for harsh environments (i.e. contact with acids, alkaline solutions, detergents or oils).