

19" Power Supplies AC-DC and DC-DC

VERO

Danica
SUPPLY



Power Supply Systems

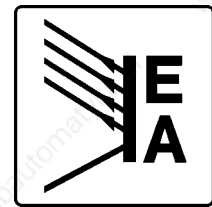

EA-Elektro-Automatik

Founded in 1974 EA-Elektro-Automatik began manufacturing power supplies for light industrial markets and laboratory/test applications. With this experience and having developed a reputation for intelligent and reliable design, in 1993 Elektro-Automatik developed a new series power supplies created specifically for the telecomms industry.

Today Elektro Automatik are regarded as one of the worlds leading suppliers of secure DC systems to the mobile communications industry. With more than 25 years experience in power, EA remain focused on developing new power conversion technologies and offering their customers an unrivalled service in both standard product and custom designed solutions.

Represented across the globe, EA-Elektro-Automatik employ more than 270 people in its modern 10,000m² production and development facility in Viersen, Germany.

Today's rapidly expanding and diversifying telecomms market demands efficient design and short production lead-times, it is through recognising and reacting to these goals that Elektro-Automatik is now the preferred supplier to the world of telecommunications.



EA-Elektro-Automatik

Vero and Danica – Power Supplies

EA-Elektro-Automatik is the original equipment manufacturer of two of Europe's most respected names in power supplies; Vero and Danica Supply.

In 2000 EA created the most comprehensive range of power supplies perhaps ever available from a single manufacturer. The EA, Vero and Danica brands combine to offer our customers a variety of solutions in markets ranging from light industrial through to mobile communication.

VERO Power Supplies

VERO

Founded in 1976, Vero Electronics designed and manufactured power supplies primarily for pluggable 19" rack applications. From this solid grounding, Vero developed many bespoke solutions for customers across the globe.

Now part of the EA-Elektro-Automatik power supplies group, the manufacturing plant in Bremen has seen extensive investment and modernisation, creating a truly world class production facility.

Danica Power Supplies

Danica SUPPLY

In 2000, EA-Elektro-Automatik began the production of the Danica series of high quality telecom power supplies. The Danica brand has stood as a quality benchmark in the telecommunications market for the past 25 years. EA's manufacturing plant in Viersen has been extended significantly to cater for the ever-increasing demand for power supplies in the telecommunications market.



VERO + Danica Power Supplies

Introduction

EVOLUTION

In the mid-1970's new, switched mode technology, offered significant benefits in terms of power density to power over the existing linear designs then in common use. Today, power supplies have evolved to a point where high performance units range from 30 to 3000 Watts, with AC or DC input, single or multiple outputs, with power factor correction available on units from 80 wattsthe .

RESEARCH AND DEVELOPMENT

Research and development is important to VERO + Danica brands, and extensive R & D resource is dedicated to developing new products for ever changing markets. These new products employ state-of-the-art circuit technology to ensure optimum performance.

STANDARD OR CUSTOM

VERO + Danica offers a comprehensive range of standard power supplies. Flexible product design allows easy modification, even for relatively small quantities. VERO + Danica also design, develop and manufacture to customer requirements.

POWER FACTOR COMPLIANCE

Power supplies featuring active power factor correction and complying fully with the requirements of EN61000-3-2 are available as standard product.

The Manufacturing Sites

From Elektro-Automatik's state-of-the-art facilities it is in a position to service any power supply requirement with which it is currently presented.

CAD and circuit simulation systems are linked directly to drilling and routing machines, our company has taken the initiative and equipped its power supply manufacturing facilities with numerous sophisticated custom systems for test and power supply burn-in.

Each design is tested with a thermal imaging system. This allows engineers to determine the areas of the power supply that would benefit from additional or improved cooling.

The core of the power supply final test facility, is centred around automatic functional test equipment. Here, power supplies are tested under stress and not by passive means. The high voltage, earth continuity testing and burn-in facilities are custom systems, designed in-house. All of these facilities are computer controlled and can be configured to include customer's own profiles. These systems are linked into the main product database, providing a total history of each power supply manufactured.

European legislation places responsibility on OEMs to ensure that their apparatus or equipment complies with the requirements of #83/336/EEC - the European Union EMC Directive. Elektro-Automatik has invested significant resources in ensuring that its products not only meet, but exceed, the requirements of European regulations, compliance statements are available on request.

All test systems are bar-code linked to the main database. This allows total traceability at all stages of the manufacture and test procedures for total quality control.



CAD Work station

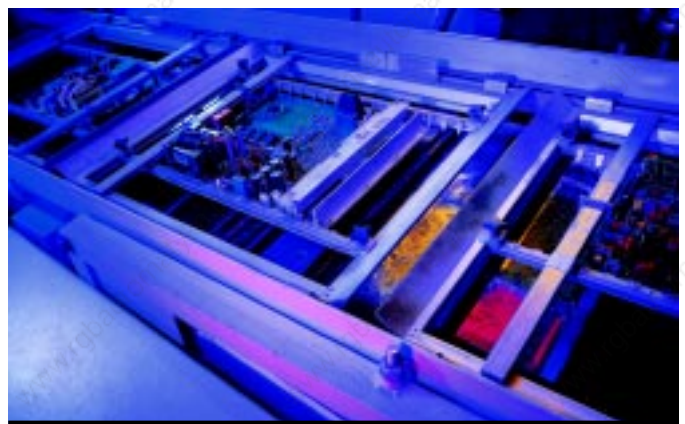

Soldering machine

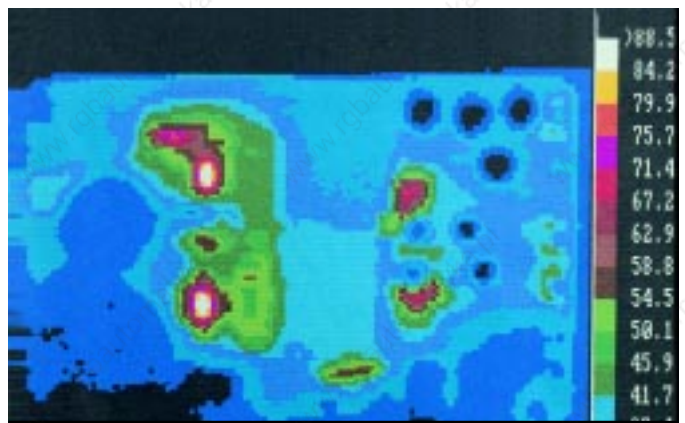

Test image from thermal camera



EMC Radiation testing

Standard and custom products

STANDARD POWER SUPPLIES

VERO + Danica has a number of strengths, pre eminent among which is its highly respected standard product range. This range of products maintains VERO + Danica's reputation for designing reliable, high quality products.

Euromodular VP80, VP150 and TPS Series

The latest units to be introduced by EA , the VP80 and VP150 feature harmonic correction over two years in advance of the date on which it becomes mandatory.

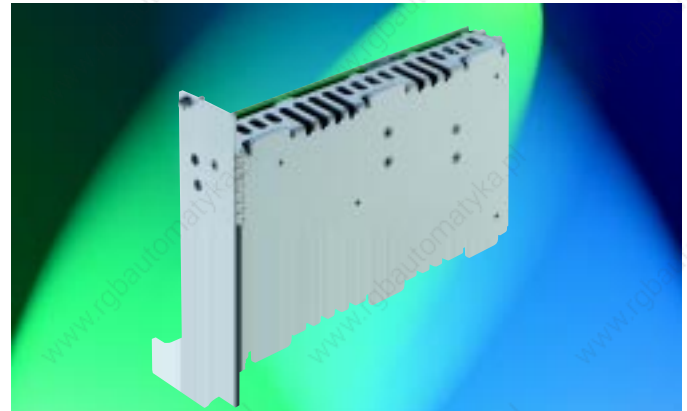

VP80-4

Open frame/Cased Series

A quality range of industry standard open frame/cased power supplies for use in systems. Universal input allows any system into which these power supplies are integrated to be used anywhere in the world - without physically selecting the input voltage.



Open frame Power Supplies: PO500

CUSTOM POWER SUPPLIES

Building on the success of the established, and proven, procedures utilised in the production of the standard product lines EA design and build power supplies to suit specific customer requirements. All custom units - irrespective of the total number produced - are manufactured and tested to the same rigorous standards as our standard product, reassuring our customers that the delivered units will meet his requirements *exactly*.

Railway Power Supplies

EA offers a range of 19" Euromodular power supplies designed specifically for use in the rail industry. These units are ruggedised - both electrically and mechanically - to withstand harsh environmental conditions.

Telecom power supplies

EA has established itself as one of the leading manufacturers of bulk custom power supplies, particularly those which relate to N+1 and modular plug-in designs. As a consequence of designing and developing a number of custom battery backup systems for telecoms OEMs, EA has evolved a range of standard solutions for battery backed, secure DC telecoms systems.

EA, VERO + Danica power supplies can be found in applications from mobile telephone base stations through to air traffic control systems and railways - proving the strength of VERO + Danica's design and manufacturing capabilities in a variety of challenging environments.



19"-Module VERO TRIVOLT



Custom power supply

Contents

AC-DC					
Style	Output power	Input Voltage	Outputs	Series	Page
19"-Rack	30 Watt	110/230 VAC	1	PK 30	13
		110/230 VAC	2	PK 30	17
	50 Watt	110/230 VAC	1	EC 50	23
		110/230 VAC	3	EC 50	25
		110/230 VAC	3	PK 60	19
	60 Watt	110/230 VAC	1	PK 60	13
		110/230 VAC	2	PK 60	17
		110/230 VAC	3	PK 60	19
		110/230 VAC PFC	1	VP80	8
	80 Watt	110-230 VAC PFC	2	VP80	8
		110-230 VAC PFC	3	VP80	8
		110-230 VAC PFC	4	VP80	8
		110-230 VAC	1	TPS 3102	32
	100 Watt	110/230 VAC	3	TPS 3102	32
		110/230 VAC	3	PK120	13
	120 Watt	110/230 VAC	1	PK120	13
		110/230 VAC	3	PK120	19
	125 Watt	110/230 VAC	3	EC 125	25
	150 Watt	110-230 VAC	1	TPS 3152	32
		110-230 VAC	3	TPS 3152	32
		110-230 VAC PFC	3	VP 150	8
	240 Watt	110/230 VAC	1	PK 240	13
		110/230 VAC	3	PK 240	19
	550 Watt	93-264 VAC PFC	1	TPS 4000	34
	1200 Watt	176-264 VAC PFC	1	TPS 5000	35
	1800 Watt	176-264 VAC PFC	1	TPS 5500	36
	3000 Watt	176-264 VAC PFC	1	TPS 6000	37
Openframe	500 Watt	110-230VAC PFC	3	PO 500-3	30

* Power supplies with wide range input can be used as DC-DC converter, consult the sales office.

DC-DC CONVERTER					
Style	Output Power	Rated Input Voltage	Outputs	Series	Page
19"-Rack	30 Watt	12/24/48VDC	1	GK 30	42
		12/24/48VDC	2	GK 30	45
	60 Watt	24/48 VDC	1	GK 60	42
		12/24/48VDC	2	GK 60	45
		12/24/48VDC	3	GK 60	47
	100 Watt	24/48VDC	1	TPS 133	39
	120 Watt	24/48VDC	1	GK 120	42
		24/48VDC	3	GK 120	47
	125 Watt	24/48VDC	3	TPS 264	39
	150 Watt	24/48VDC	1	TPS 233	39
	250 Watt	12/24/48/110VDC	1	TPS 168	39

AC-DC Power Supplies

- VP-Series
- PK-Series
- EC-Series
- TPS-Series

ac-dc

ac-dc

ac-dc

ac-dc

ac-dc

ac-dc

ac-dc

ac-dc

ac-dc

ac-dc

ac-dc

ac-dc

AC-DC

AC-DC power supplies



VP Series, Power Supplies with active PFC

The latest 19" plug-in power supplies from VERO + Danica are designed to meet the requirements of EN61000-3-2 incorporating active PFC (Power Factor Correction). Active PFC allows a power factor of $\gg 1$ so the waveform exactly matches the shape of the mains voltage wave.

19" - Power Supply Modules

A wide range of rectifier chargers are available to form the core of a reliable secure DC system. Hot-swap, N+1, remote sense and active power sharing features are available on these standard modules.

COST-OPTIMISED POWER SUPPLIES

The EC range is a family of cost-optimised power supplies with power outputs ranging from 50 to 125 Watt and single, dual or triple outputs.

OPEN FRAME/CASED POWER SUPPLIES

EA has a wide range of competitive open frame converters with power ranging from 40 to 500 Watts and 1 to 3 outputs for computer and datacommunications applications.

VP - Series, Power Supplies with PFC



VP 80
VP 150

AC-DC

VP 80/150 Series: 1-4 outputs, active PFC

Primary switched mode plug-in power supply with power factor correction for 19" applications in accordance with DIN 41494

Features

- Active Power Factor Correction (PF»1)
- Wide 94 - 253VAC input range without modification
- Direct plug-up into backplanes
- Compact design
- **Power share, V1, V2 and multiple output units**
- CE compliant EMC and LV Directives
- EMC Design (IEEE 1101.10 front panel)
- Safety in accordance with EN60950, UL, cUL

The latest units to be introduced by EA , the VP80 and VP150 feature harmonic correction.

The single converter technology employed in the VP Series allows load sharing on multiple outputs. In addition, the power density has increased by more than 30%, enabling the units to supply 80 watts from a cassette measuring only 3U x 7HP (160mm deep).

All units of the VP-Series carry the CE mark according to the relevant standards and are cUL listed.

EA VP-Series at the heart of a system

The mechanical design of the power supply allows for operation in systems with integrated backplanes, permitting the power supply to be plugged directly into the board. The physical width of the cassette complies with the 4HP grid used in standard backplane layout, so the 80 Watt version fits into an 8HP wide space. This means that the power supply is only 2 slots wide (guide positions 1 or 2 are possible).

There is no heatsink on the rear, so the units can be plugged directly to the backplane.

New: N+1 redundant variants VP 80-1R

Ordering information

Description: Mating connectors	Order code
Mating connector coded H15 to DIN 41612	17-10115K
Coding keys (pkt 10)	17-10064F

Ordering information

Description: VP80-Series: 3U x 7HP / VP150 Series: 3U x 12HP

Type	Outputs	Order-Code Without front panel	Order-Code Front panel 8HP Std.
VP80-1-R 5V	5V/16A	116-020043E	116-020047D
VP80-1-R 12V	12V/6,7A	116-020044B	116-020048A
VP80-1-R 15V	15V/5,3A	116-020045K	116-020049J
VP80-1-R 24V	24V/3,3A	116-020046G	116-020050K
VP80-1 5V	+5V/16A	116-020006A	116-020015L
VP80-1 12V	+12V/6,7A	116-020007J	116-020016H
VP80-1 15V	+15V/5,3A	116-020008F	116-020017E
VP80-1 24V	+24V/3,3A	116-020009C	116-020018B
VP80-2A	+12V/5A; -12V/2A	116-020010D	116-020019K
VP80-2B	+15V/4A; -15V/2A	116-020011A	116-020020L
VP80-2C	+5V/12A; +12V/2A	116-020012J	116-020021H
VP80-2D	+5V/5A; +24V/2,5A	116-020013F	116-020022E
VP80-2E	+12V/2A; +24V/2,5A	116-020014C	116-020023B
VP80-3A	5V/12A; ±12V/1A	116-020000H	116-020024K
VP80-3B	5V/12A; ±15V/1A	116-020001E	116-020025G
VP80-3C	5V/12A; +12V/4A; -12V/1A	116-020002B	116-020026D
VP80-3D	5V/12A; +15V/3A; -15V/1A	116-020003K	116-020027A
VP80-4	3,3V/3A; 5V/12A; +12V/4A; -12V/1A	116-020004G	116-020028J
VP150-3	5V/18A; +12V/5A; -12V/2A	-	116-031530B



VP Series

Technical Data VP Series

Input specification	
Input voltage:	94-253VAC
Input frequency:	47-63Hz
Inrush surge current limit:	<27A (NTC)
Input overvoltage protection:	VDR
Hold up time (Nominal V _{IN} ; 100% I _{OUT}):	>20ms
Power Factor:	>0,97
Efficiency:	typ. 75%
Safety (Compliant with Low Voltage Directive 73/23/EEC)	
Safety standards:	EN60950, IEC 950, UL1950, cUL
EMC (Compliant with EMC Directive 89/336/EEC)	
Emmissions:	EN 55022/B (0,15-30MHz); EN 55022/B (30-1000MHz)
Immunity:	EN 50082-2
Electro Static Discharge:	EN 61000-4-2
Electrical fast transients/Burst:	EN 61000-4-4
RF Conducted disturbance:	EN 50141
RF Field susceptibility:	EN 50140
Surge susceptibility:	EN 61000-4-5
Harmonic distortion:	EN 61000-3-2
Environmental	
Operating temperature:	0°C to +70°C
Storage temperature:	-25°C to +85°C
Derating:	2W/°C above 45°C natural convection 4W/°C above 60°C forced air cooling (1m/s)
Relative Humidity:	max. 90% non-condensing
Temperature coefficient:	<0,05%/°C
Physical	
Case material / finish:	Steel and aluminium cassette

AC-DC

VP Series: 1-4 outputs, active PFC

Output specification

VP80-1	V1	V1	V1	V1
Output voltage:	5V	12V	15V	24V
Output adjustment range:	4,8-5,5V	11-13V	14-16V	22-26V
Output current:1)	16A	6,7A	5,3A	3,3A
Ripple:	<40mV _{pp}			
Current limit:	>16,1A	>6,75A	>5,35A	>3,35A
Short circuit protection:	electronic, automatic restart			
Overvoltage protection (OVP):	6-6,7V	15,5-18V	17-21V	27-32V
Powerfail-Signal (at full load) >6ms before V _{OUT} :	<4,8V	<11,5V	<14,4V	<23V
Line regulation (100% I _{OUT}): Δ iV _{OUT}	<0,2%			
Load regulation static (10...90% I _{OUT}): Δ iV _{OUT}	<0,2%			
Transient response (10...90% I _{OUT}):	<1ms			
Voltage compensation with SENSE max.:	0,5V			
Derating:	2W/°C above 45°C - natural convection, 4W/°C above 60°C - forced air cooling (1m/s)			

VP80-2	Version A		Version B		Version C	
	V1	V2	V1	V2	V1	V2
Output voltage:	+12V	-12V	+15V	-15V	+5V	+12V
Output adjustment range:	fixed	fixed	fixed	fixed	4,8-5,5V	fixed
Output current:1)	5A	2A	4A	2A	12A	2A
Ripple:	<40mV _{pp}					
Current limit:	>5,1A	>2,1A	>4,1A	>2,1A	>12,1A	>2,1A
Short circuit protection:	electronic, automatic restart					
Overvoltage protection (OVP):	—	—	—	—	6-6,7V	—
Powerfail Signal (at full load) >6ms before V _{OUT} :	—	—	—	—	<4,8V	—
Line regulation (100% I _{OUT}): Δ iV _{OUT}	<0,2%					
Load regulation static (10...90% I _{OUT}): Δ iV _{OUT}	<0,5%	<1,5%2)	<0,5%	<1,5%2)	<0,5%	<±4%2)
Transient response (10...90% I _{OUT}):	<1ms					
Voltage compensation with SENSE max.:	—	—	—	—	0,5V	—
Derating:	2W/°C above 45°C - natural convection, 4W/°C above 60°C - forced air cooling (1m/s)					

VP80-2	Version D		Version E	
	V1	V2	V1	V2
Output voltage:	+5V	+24V	+12V	+24V
Output current adjustment:	fixed	22-26V	fixed	22-26V
Output current:1)	5A	2,5A	2A	2,5A
Ripple:	<40mV _{pp}			
Current limit:	>5,1A	>2,5A	>2,1A	>2,5A
Short circuit protection:	electronic, automatic restart			
Overvoltage protection (OVP):	6-6,7V	—	—	—
Powerfail Signal (at full load) >6ms before V _{OUT} :	>4,8V	—	—	—
Line regulation (100% I _{OUT}): Δ iV _{OUT}	<0,2%			
Load regulation static (10...90% I _{OUT}): Δ iV _{OUT}	<0,5%	<1,5%2)	<0,5%	<1,5%2)
Transient response (10...90% I _{OUT}):	<1ms			
Voltage compensation with SENSE max.:	0,5V	—	—	—
Derating:	2W/°C above 45°C - natural convection, 4W/°C above 60°C - forced air cooling (1m/s)			

1) Maximum output power: 80 Watt, see derating
 2) P_{OUT} V1 min. 5 Watt

AC-DC

VP Series: 1-4 outputs, active PFC

Output specification

VP80-3	Version A		Version B	
	V1	V2/V3	V1	V2/V3
Output voltage:	5V	±12V	5V	±15V
Output voltage adjustment:	4,8-5,5V	fixed	4,8-5,5V	fixed
Output current:1)	12A	1A	12A	1A
Ripple:	<40mV _{PP}	<10mV _{PP}	<40mV _{PP}	<10mV _{PP}
Current limit:	>12,1A	>1,01A	>12,1A	>1,01A
Short circuit protection:	electronic, automatic restart			
Overvoltage protection (OVP):	6-6,7V	—	6-6,7V	—
Powerfail Signal (full load) >6ms before V _{OUT} :	<4,8V	—	<4,8V	—
Line regulation (100% I _{OUT}): Δ i _{VOUT}			<0,2%	
Load regulation static (10...90% I _{OUT}): Δ i _{VOUT}	<0,5%	<1,5%2)	<0,5%	<1,5%2)
Transient response (10...90% I _{OUT}):	<1ms			
Voltage compensation with SENSE max.:	0,5V	—	0,5V	—
Derating:	2W/°C above 45°C - natural convection, 4W/°C above 60°C - forced air cooling (1m/s)			

VP80-3	Version C			Version D		
	V1	V2	V3	V1	V2	V3
Output voltage:	5V	+12V	-12V	5V	+15V	-15V
Output voltage adjustment:	4,8-5,5V	fixed	fixed	4,8-5,5V	fixed	fixed
Output current:1)	12A	4A	1A	12A	3A	1A
Ripple:	<40mV _{PP}	<40mV _{PP}	<10mV _{PP}	<40mV _{PP}	<40mV _{PP}	<10mV _{PP}
Current limit:	>12,1A	>4,1A	>1,01A	>12,1A	>3,1A	>1,01A
Short circuit protection:	electronic, automatic restart					
Overvoltage protection (OVP):	6-6,7V	—	—	6-6,7V	—	—
Powerfail Signal (full load) >6ms before V _{OUT} :	<4,8V	—	—	<4,8V	—	—
Line regulation (100% I _{OUT}): Δ i _{VOUT}				<0,2%		
Load regulation static (10...90% I _{OUT}): Δ i _{VOUT}	<1%	<±4%2)	<1,5%2)	<1%	<±4%2)	<1,5%2)
Transient response (10...90% I _{OUT}):	<1ms					
Derating:	2W/°C above 45°C - natural convection, 4W/°C above 60°C - forced air cooling (1m/s)					

VP80-4	V1	V2	V3	V4
	Output voltage:	+3,3V	+5V	+12V
Output voltage adjustment:	fixed	4,8-5,5V	fixed	fixed
Output current:1)	3,0A	12A	4A	1A
Ripple:	<20mV _{PP}	<40mV _{PP}	<40mV _{PP}	<10mV _{PP}
Current limit:	>3,01A	>12,1A	>4,1A	>1,01A
Short circuit protection:	electronic, automatic restart			
Overvoltage protection (OVP):	—	6-6,7V	—	—
Powerfail Signal (full load) >6ms before V _{OUT} :	—	<4,8V	—	—
Line regulation (100% I _{OUT}): Δ i _{VOUT}			<0,2%	
Load regulation static (10...90% I _{OUT}): Δ i _{VOUT}	<±4%	<1%	<1,5%3)	<1,5%3)
Transient response (10...90% I _{OUT}):	<1ms			
Derating:	2W/°C above 45°C - natural convection, 4W/°C above 60°C - forced air cooling (1m/s)			

1) Maximum output current: 80 Watt, see derating

2) I_{OUT} V1 min. 1A

3) I_{OUT} V2 min. 1A

VP150-3	V1	V2	V3
	Output voltage:	+5V	+12V
Output voltage adjustment:	4,5...5,5V	11,8...15,2V	-11,8...-15,2V
Output current:1)	20A	4A	2A
Ripple:	<40mV _{PP}	<20mV _{PP}	<20mV _{PP}
Current limit:	>20,5A	>25A	>2,7A
Short circuit protection:	electronic, automatic restart		
Overvoltage protection (OVP):	6 - 6,7V	16 - 18V	-16 - 18V
Powerfail Signal (full load) >5ms before V _{OUT} :	>4,8V	—	—
Line regulation (100% I _{OUT}): Δ i _{VOUT}	>0,2%		
Load regulation static (10...90% I _{OUT}): Δ i _{VOUT}	<0,2%	<0,2%	<0,2%
Transient response (10...90% I _{OUT}):	<1ms		
Derating:	4W/°C ab 45°C -above 45°C - natural convection, 8W/°C above 60°C - forced air cooling (1m/s)		

1) Maximum output power: 150 Watt, see derating

VP Series: 1-4 outputs, active PFC

Mechanical details

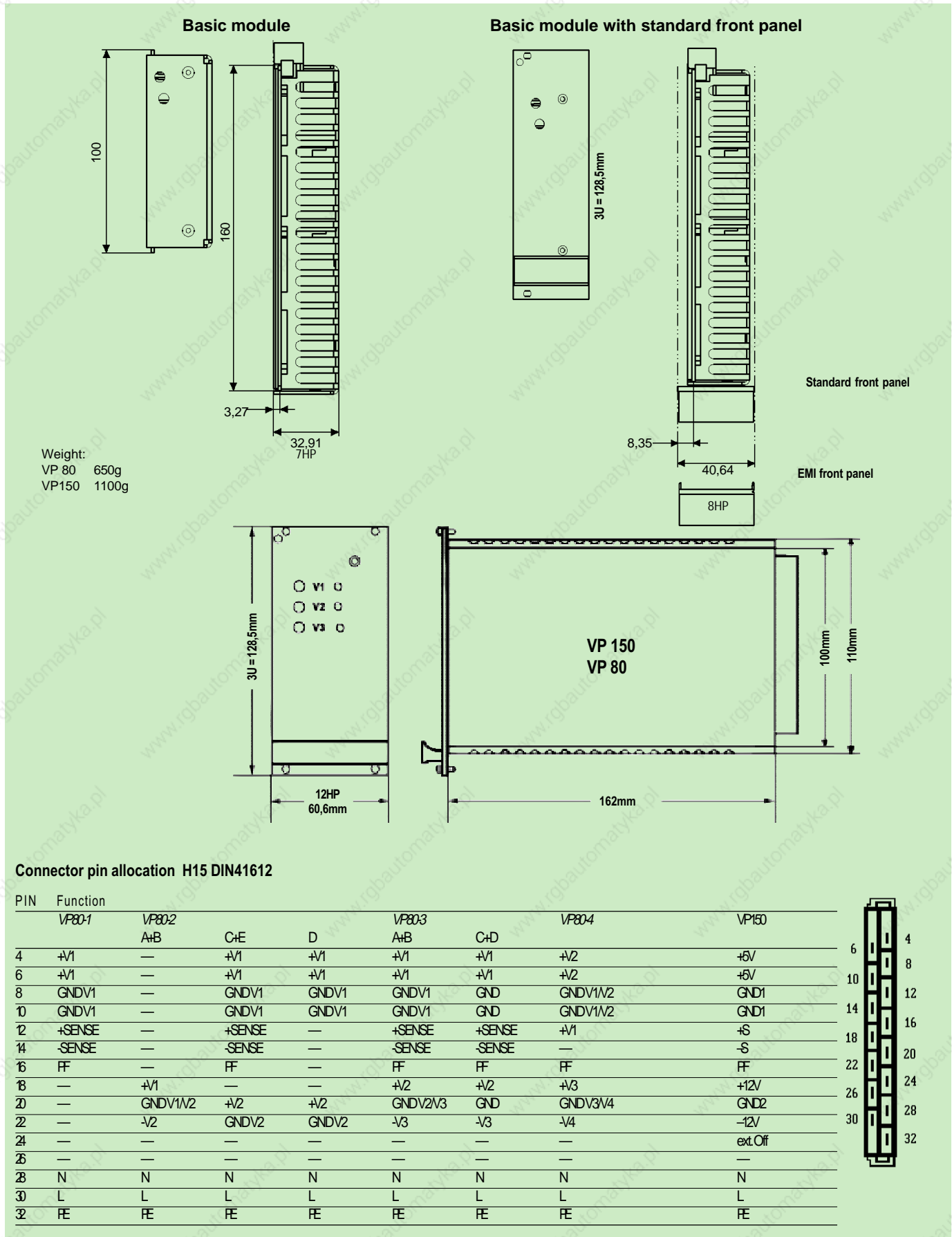

Note: Sense lines must be connected. For maximum compensation for supply lead voltage drop they should be connected as close to the load as possible

AC-DC

19"- Power Supplies PK-Series

AC-DC



- PK30
- PK60
- PK60-R
- PK120
- PK125
- PK250

PK-Series: MONOVOLT

Primary switched mode power supplies for use in 19" subracks to DIN41494, 30 to 240 Watt output power.

Features

- Compact, rugged design
- high regulation accuracy
- Safety to approvals UL, cUL and EN60950
- CE marked for compliance to EMC and Low Voltage Directives
- SENSE operation
- Overvoltage protection (OVP)
- Powerfail signal
- Remote On/Off
- Short circuit and no load protected
- Coded H15 connector
- Standardized pinning



PK-Series MONOVOLT Power Supplies

Ordering information

Description:

PK Series Power Supplies 30W Output power			Order-Code
Type	Output	without Powerfail	with Powerfail
PK30 3Ux8HP	5V/6A	116-010016D*	-
PK30 3Ux8HP	12-15V/2A	116-010215H	-
PK30 3Ux8HP	24V/1,5A	116-010216E	-

Description: PK Series; 60Watt Output power

PK60 3Ux8HP	3,3V/15A	116-010196L	-
PK60 3Ux8HP	5V/12A	116-010063D*	116-010074H*
PK60 3Ux8HP	12V/5A	116-010064A*	-
PK60 3Ux8HP	15V/4A	116-010065J*	-
PK60 3Ux8HP	24V/2,5A	116-010066F*	116-010077K*
PK60-R 3Ux8HP	5V/12A	116-010128L#	-
PK60-R 3Ux8HP	12V/5A	116-010219G#	-
PK60-R 3Ux8HP	15V/4A	116-010220H#	-
PK60-R 3Ux8HP	24V/2,5A	116-010129H#	-

Description: PK Series; 120Watt Output power

PK120 3Ux14HP	5V/20A	116-010069H	116-010081B
PK120 3Ux14HP	12V/10A	116-010070J	116-010082K
PK120 3Ux14HP	15V/8A	116-010071F	-
PK120 3Ux14HP	24V/5A	116-010072C	116-010084D

Description: PK Series; 240Watt Output power

PK240 3Ux24HP	5V/45A	-	116-010163K
PK240 6Ux14HP	5V/45A	-	116-010125J
PK240 3Ux24HP	12V/20A	-	116-010164G
PK240 6Ux14HP	12V/20A	-	116-010126F
PK240 3Ux24HP	24V/10A	-	116-010165D
PK240 6Ux14HP	24V/10A	-	116-010127C

Accessories:

Reduced height front panel: PK30	148-010012F
Reduced height front panel: PK60	148-010021E
Reduced height front panel: PK120	148-010019G
Mating connector coded H15 to DIN 41612	017-010115K
Coding keys (pkt10)	017-010064F
Mating connector coded DIN 41612, H15+2HA/L Faston	017-010138K

For applications ruled under EN 61000-3-2, we recommend the use of the **VP80** series.

Technical Data PK Series: Monovolt

Input specification

Input voltage (switchable):	115/230VAC
Input frequency:	47-63Hz
Inrush surge current limitation:	by NTC resistor m20A (cold start)
Input overvoltage protection:	by VDR
Hold up time (Nominal V_{IN} ; 100% I_{OUT}):	>20ms
Efficiency:	typ. >80%

Safety (Compliant with Low Voltage Directive 73/23/EEC)

Certified to, or meets the requirement of:	EN60950, UL1950
--	-----------------

EMC (Compliant with EMC Directive 89/336/EEC)

Emmissions:	EN 55022/B (0,15-30Mhz); EN 55022/B (30-1000MHz)
Immunity:	EN 50082-2
Electro Static Discharge:	EN 61000-4-2
Electrical fast transients/Burst:	EN 61000-4-4
RF Conducted disturbance:	EN 50141
RF Field susceptibility:	EN 50140

Environmental

Operating temperature:	0°C to +70°C
Storage temperature:	-25°C to +85°C
Relative humidity:	Non-condensing 5% - 95%

Physical

Case material/finish:	Clear anodised, ventilated aluminium cassette with cooling cutouts and front or rear heat sinks as required. DIN 41494 part 5 compatible
-----------------------	---

* EN60950 and UL certified

EN60950 and cUL certified

PK Series: MONOVOLT

Output specification

PK30	V1	V1	V1
Output voltage:	5V	12V	24V
Output adjustment range:	4,8-5,5V	12-15V	22-26V
Output current:	0-6A	0-2,5A	0-1,5A
Ripple:	<40mV _{PP}	<20mV _{PP}	<20mV _{PP}
Line regulation (100% I _{OUT}): Δ iV _{OUT}	<0,2%	<0,02%	<0,02%
Load regulation static (10...90% I _{OUT}): Δ iV _{OUT}	<0,2%	<0,5%	<0,5%
Transient response (10...90% I _{OUT}):		1ms	
Switching frequency, converter type:		20-50kHz	fly back converter
Current limit:	>6,5A	>2,6A	>1,5A
Short circuit protection:		continuous, automatic restart	
Overvoltage protection (OVP):	6-6,7V	-	-
Powerfail-Signal (at full load) >6ms before V _{OUT} :		-	-
Temperature-coefficient/°C:		0,02%	
Voltage compensation with SENSE max. NOTE 1:		0,5V	
Derating:		1W/°C above 55°C	

PK60	V1	V1	V1	V1	V1
Output voltage:	3,3V	5V	12V	15V	24V
Output adjustment range:	1,8-3,5V	4,5-5,5V	11-13V	13,5-16,5V	22-26V
Output current:	0-15A	0-12A	0-5A	0-4A	0-2,5A
Ripple:			<40mV _{PP}		
Line regulation (100% I _{OUT}): Δ iV _{OUT}	<0,3%	<0,3%	<0,2%	<0,2%	<0,2%
Load regulation static (10...90% I _{OUT}): Δ iV _{OUT}			<0,2%		
Transient response (10...90% I _{OUT}):	1ms	0,8ms	0,5ms	0,5ms	0,5ms
Switching frequency, converter type:			100kHz	forward converter	
Current limit:	>15,5A	>12,5A	>5,3A	>4,3A	>2,7A
Short circuit protection:			continuous, automatic restart		
Overvoltage protection (OVP):	2,8-5,0V	5,5-6,0V	13,2-15,0V	16,5-18,0V	26,4-30,0V
Powerfail-Signal (at full load) >6ms before V _{OUT} :		-	-		
Temperature-coefficient/°C:			0,02%		
Voltage compensation with SENSE max. NOTE 1:			0,5V		
Derating:			1,6W/°C above 45°C		

PK60-Redundant	V1	V1	V1	V1
Output voltage: (fixed):	5V±1%	12V±1%	15V±1%	24V±1%
Output current:	0-12A	0-5A	0-4A	0-2,5A
Ripple:			<40mV _{PP}	
Line regulation (100% I _{OUT}): Δ iV _{OUT}			<0,2%	
Load regulation static (10...90% I _{OUT}): Δ iV _{OUT}			<0,2%	
Transient response (10...90% I _{OUT}):			1ms	
Switching frequency, converter type:			100kHz	forward converter
Current limit:	>12,5A	>5,3A	>4,3A	>2,7A
Short circuit protection:			continuous, automatic restart	
Overvoltage protection (OVP):	6,0-6,7V	13,2-15,0V	16,5-18,0V	27,0-29,0V
Temperature-coefficient/°C:			0,02%	
Current sharing at redundant use with ASF signal:	>2,4A	>1,0A	>0,8A	>0,5A
Voltage compensation with SENSE max. NOTE 1:			0,5V	
DC-FAIL signal:	Active low when unit fails (NPN-open collector signal; 20mA; I _{O,4A})			
Derating:			2W/°C above 55°C	

AC-DC

PK Series: MONOVOLT

Output specification

PK120	V1	V1	V1	V1
Output voltage:	5V	12V	15V	24V
Output adjustment range:	4,5-5,5V	10,8-13,2V	13,5-16,5V	21,6-26,4V
Output current:	0-20A	0-10A	0-8A	0-5A
Ripple:			>40mV _{PP}	
Line regulation (100% I _{OUT}): Δ iV _{OUT}			>0,2%	
Load regulation static (10...90% I _{OUT}): Δ iV _{OUT}			>0,2%	
Transient response (10...90% I _{OUT}):			0,5ms	
Switching frequency, converter type:		100kHz	forward converter	
Current limit:	>22A	>11A	>8,8A	>5,5A
Short circuit protection:		continuous, automatic restart		
Overvoltage protection (OVP):	5,0-7,0V	12,0-16,5V	15,0-21,0V	27,0-29,0V
Powerfail-Signal (at full load) >6ms before V _{OUT} :	>4,8V	>11,5V	>14,4V	>23,0V
Temperature-coefficient/°C:			0,02%	
Voltage compensation with SENSE max.NOTE 1:			0,5V	
Derating:		2,4W/°C above 55°C		

PK240	V1	V1	V1
Output voltage:	5V	12V	24V
Output adjustment range:	4,5-5,5V	11-13V	22-26V
Output current:	0-45A	0-20A	0-10A
Ripple:		>40mV _{PP}	
Line regulation (100% I _{OUT}): Δ iV _{OUT}	>0,2%	>0,35%	>0,5%
Load regulation static (10...90% I _{OUT}): Δ iV _{OUT}		>0,2%	
Transient response (10...90% I _{OUT}):		0,5ms	
Switching frequency, converter type:		45kHz	push-pull converter
Current limit:	>46A	>22A	>12A
Short circuit protection:		continuous, automatic restart	
Overvoltage protection (OVP):	5,5-6,5V	14,0-18,0V	26,4-30,0V
Powerfail-Signal (at full load) >6ms before V _{OUT} :	>4,8V	>11,5V	>23V
Temperature-coefficient/°C:			0,02%
Voltage compensation with SENSE max.NOTE 1:			0,5V
Derating:		3HE: 8W/°C above 55°C, 6HE: 4W/°C above 55°C	

PK Series: MONOVOLT

Mechanical details

PK30, PK60

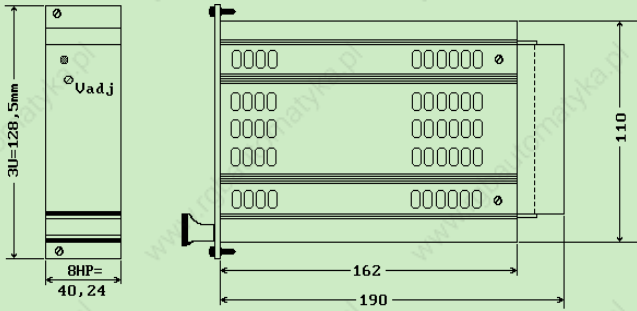

Weight: PK30, PK60, PK60R 850g

PK 60-R

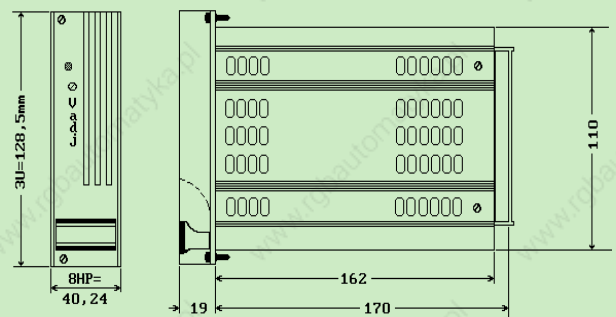

PK120

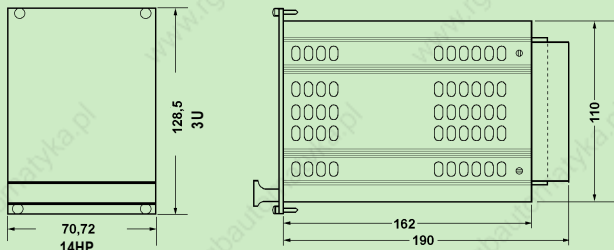

Weight: PK120 1350g

PK240

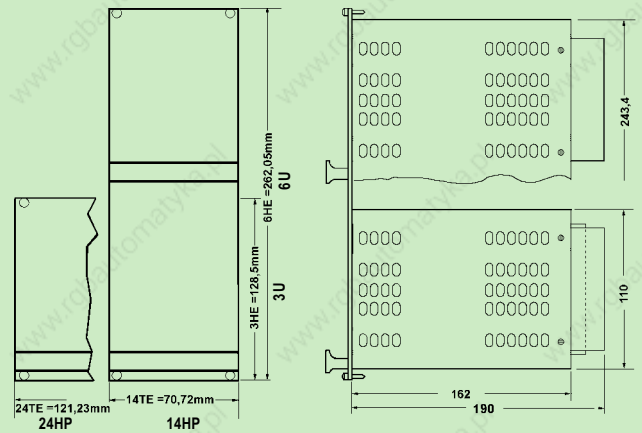

Weight: PK240 2200g

Connector pin allocation H15-Connector

PN	Function PK30	Function PK60	Function PK60-R	Function PK120
4	+Vout	+Vout	+Vout	+Vout
6	+Vout	+Vout	+Vout	+Vout
8	-Vout	-Vout	-Vout	-Vout
10	-Vout	-Vout	-Vout	-Vout
12 <small>Anm. 1</small>	+SENSE	+SENSE	+SENSE	+SENSE
14 <small>Anm. 1</small>	-SENSE	-SENSE	-SENSE	-SENSE
16	—	Ext I/O+	—	Ext I/O+
18	—	PF _Q	DC FAIL	PF _Q
20	—	—	ASF	—
22	—	PF _Q	—	PF _Q
24	—	Ext I/O-	—	Ext I/O-
26	—	—	—	—
28	N	N	N	N
30	L	L	L	L
32	E	E	E	E

Connector pin allocation H15+2HA-Connector

PN	Function PK240
I	+Vout
II	-Vout
14 <small>Note. 1</small>	+SENSE
16 <small>Note. 1</small>	-SENSE
22	Ext on/off
24	PF _Q
28	N
30	L
32	E

H15-connector

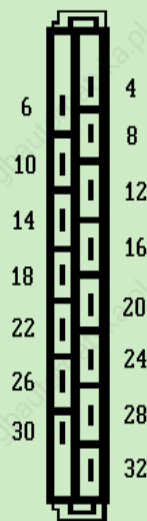

H15+2HA-Connector

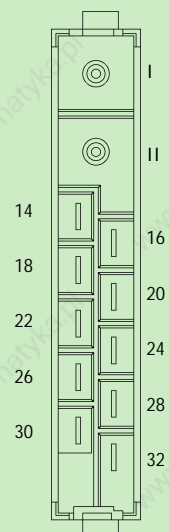

Note1: Sense lines must be connected. For maximum compensation for supply lead voltage drop they should be connected as close to the load as possible

PK-Series: BIVOLT

Primary switched mode power supplies for use in 19" subracks to DIN41494, 30 or 60 Watt output.

Features

- High regulation accuracy
- Voltages adjustable
- Compact, rugged design
- Safety approvals to UL, cUL and EN60950
- CE marked for compliance to EMC and Low Voltage Directives
- SENSE operation (5V output)
- Overvoltage (OVP) and short circuit protected
- Remote On/Off
- No minimum load required
- Coded H15 connector
- Standardized pinning



PK Series Bivolt Plug-in Power Supplies

Ordering information

Description: Bivolt PK30, PK60; 30 and 60 Watt outputs

Model	Output voltage	Order code
PK30 3U x 8HP	±12 - 15V/1A	116-010015G*

Description: Bivolt PK60, 60 Watt outputs

PK60-A 3U x 8HP	±12-15V/2A	116-010022A#
PK60-A 3U x 8HP	5V/6A;12-15V/2A	116-010024F#
PK60-C 3U x 8HP	5V/6A;24V/1,5A	116-010025C#
PK60-D 3U x 8HP	12-15V/2A;24V/1,5A	116-010080E#

Accessories:

Reduced height front panel (PK30)	148-010013C
Reduced height front panel (PK60)	148-010011J
Mating connector coded H15 to DIN 41612	017-010115K
Coding keys (pkt 10)	017-010064F

Technical Data PK Series: Bivolt

Input specification

Input voltage selectable:	115/230VAC
Input frequency:	47-63Hz
Inrush surge current limitation:	by NTC resistor
Input overvoltage protection:	by VDR
Hold up time (Nominal V_{IN} ; 100% I_{OUT}):	>20ms
Efficiency:	typ. >75%

Safety (Compliant with Low Voltage Directive 73/23/EEC)

Certified to:	EN60950, UL1950
---------------	-----------------

EMC (Compliant with EMC Directive 89/336/EEC)

Emmissions: EN 55022/B (0,15-30MHz); EN 55022/B (30-1000MHz)	
Immunity: EN 50082-2	
Electro Static Discharge: EN 61000-4-2	
Electrical fast transients/Burst: EN 61000-4-4	
RF Conducted disturbance: EN 50141	
RF Field susceptibility: EN 50140	

Environmental

Operating temperature:	0°C to +70°C
Storage temperature:	-25°C to +85°C
Relative humidity:	Non-condensing 5% - 95%

Physical

Case material/finish: Clear anodised, ventilated aluminium cassette with cooling cutouts and front or rear heat sinks as required.
DIN 41494 part 5 compatible

* EN60950 and UL certified

EN60950

AC-DC

PK-Series: BIVOLT

Output specifications

PK30	V1, V2
Output voltage:	±12V - 15V
Output adjustment range:	-
Output current:	±0-1A
Ripple:	<3mV _{PP}
Line regulation (100% I _{OUT}): Δ iV _{OUT}	<0,02%
Load regulation static (10...90% I _{OUT}): Δ iV _{OUT}	<0,5%
Transient response (10...90% I _{OUT}):	10ms
Switching frequency, converter type:	20-50kHz flyback converter
Current limit:	>2,2A
Short circuit protection:	continuous, automatic restart
Overvoltage protection (OVP):	-
Powerfail Signal (at full load) >6ms before V _{OUT} :	-
Temperature coefficient/°C:	0,02%
Voltage compensation with SENSE max.NOTE1:	0,5V
Derating:	1,3W/°C above 55°C

PK60	A:V1,V2	B:V1,V2	C:V1,V2	D:V1,V2
Output voltage:	±12-15V	5V(4,5-5,5V)/12-15V	5V(4,5-5,5V)/24V(22-26V)	12-15V/24V(22-26V)
Output current:	±0-2A	0-6/0-2A	0-6/0-1,5A	0-2/0-1,5A
Ripple:	<20mV _{PP}	<40mV _{PP}	<40mV _{PP}	<40mV _{PP}
Line regulation (100% I _{OUT}): Δ iV _{OUT}			<0,2%	
Load regulation static (10...90% I _{OUT}): Δ iV _{OUT}	<0,5%	<0,2%/0,5%	<0,2%/0,5%	<0,5%
Transient response (10...90% I _{OUT}):			1ms	
Switching frequency, converter type:			25-50kHz flyback converter	
Current limit:	>2,2A	>6,5A/>2,2A	>6,5A/>1,5A	>2,2A/>1,5A
Short circuit protection:			continuous, automatic restart	
Overvoltage protection (OVP):			fixed on 5V output, optional to special order on others	
Temperature-Coefficient/°C:			0,02%	
Voltage compensation with SENSE max.NOTE1:			0,5V maximum on 5V outputs	
Derating:			1,6W/°C above 55°C	

Mechanical details

PK30, PK60

Weight PK30, PK60: 850 g

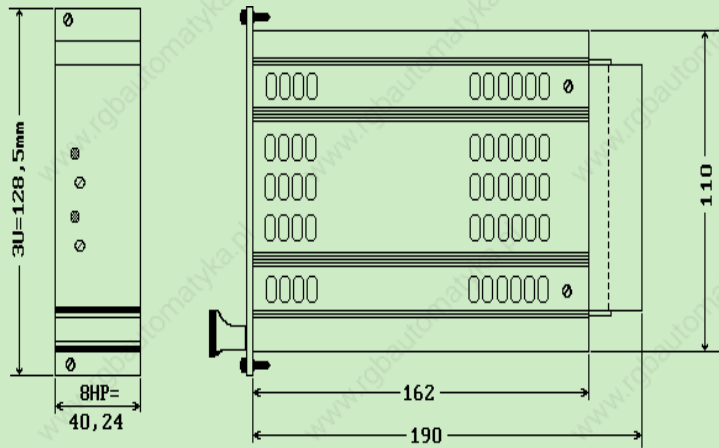

Pin allocation - H15 Connector

PIN	function					
	PK30	PK60	A	B	C	D
4	---	---	+5V	+5V	+12-15V	
6	---	---	+5V	+5V	+12-15V	
8	---	---	0V	0V	0V	
10	---	---	0V	0V	0V	
12 Note 1	---	---	+SENSE	+SENSE	---	
14 Note 1	---	---	-SENSE	-SENSE	---	
16	---	---	---	---	---	
18	+12-15V	+12-15V	---	---	---	
20	0V	0V	+12-15V	+24V	+24V	
22	-12-15V	-12-15V	0V	0V	0V	
24	---	---	---	---	---	
26	---	---	---	---	---	
28	N	N	N	N	N	
30	L	L	L	L	L	
32	E	E	E	E	E	

Note 1: Sense lines must be connected. For maximum compensation for supply lead voltage drop they should be connected as close to the load as possible.

AC-DC

PK-Series: TRIVOLT

Primary switched mode power supplies for use in 19" subracks to DIN41494, 60 to 250 Watts output.

Features

- 3 high stability outputs, all adjustable
- Safety approvals to UL, cUL and EN60950
- CE marked for compliance to EMC and Low Voltage Directives
- SENSE operation (5V output)
- Overvoltage (OVP) protection (5V output)
- Short circuit protected
- Powerfail signal
- No minimum load required
- Coded H15 connector
- Standardized pinning



PK-Series TRIVOLT Power Supply

Ordering information

Description: TRIVOLT PK60; 3U x 8HP, 60 Watt output power

Model	Outputs			Order-Code
	V1	V2	V3	
PK60-A	5V/6A	+12-15V/1A	-12-15V/1A	116-010018J*
PK60-A PF	5V/6A	+12-15V/1A	-12-15V/1A	116-010103A#
PK60-B	5V/6A	+12-15V/2A	-12-15V/0,5A	116-010101G*
PK60-B PF	5V/6A	+12-15V/2A	-12-15V/0,5A	116-010102D#

Description: Trivolt PK120; 3U x 14HP, 6U x 8HP 120Watt output power

PK120 3U	V1:5V/12A	V2/V3: ±12-15V/2A	116-010046C#
PK120 6U	V1:5V/12A	V2/V3: ±12-15V/2A	116-010047L#
PK120 6U PF	V1:5V/12A	V2/V3: ±12-15V/2A	116-010079D#
PK120 3U PF	V1:5V/12A	V2/V3: ±12-15V/2A	116-010078G#

Description: Trivolt PK125; 6U x 8HP, 125 Watt output power

	V1	V2	V3	
PK125	5V/13A	+12V/4A	-12V/1A	116-010182E

Description: Trivolt PK250-2; 6U x 14HP, 250 Watt output power

	V1	V2	V3	
PK250 with VME-Signal	5V/30A	+12V/6A	-12V/3A	116-010115B#

Description: Accessories

Reduced height front panel: PK60	148-10010A
Reduced height front panel: PK120, 3U	148-10020H
Mating connector coded H15 to DIN 41612	017-10115K
Mating connector coded H15+2HA faston to DIN 41612	017-10138K
Coding keys (pkt 10)	017-10064F

Note: PF = Powerfail

Technical Data PK Series: Trivolt

Input specification

Input voltage switchable:	115/230VAC
Input frequency:	47-63Hz
Inrush surge current limitation:	by NTC resistor
Input overvoltage protection:	by VDR
Hold up time (Nominal V_{IN} ; 100% I_{OUT}):	>20ms
Efficiency:	typ. >75%

Safety (Compliant with Low Voltage Directive 73/23/EEC)

Certified to: EN60950, IEC 950, UL1950, VDE 0805

EMC (Compliant with EMC Directive 89/336/EEC)

Emmissions: EN 55022/B (0,15-30MHz); EN 55022/B (30-1000MHz)	
Immunity:	EN 50082-2
Electro Static Discharge:	EN 61000-4-2
Electrical fast transients/Burst:	EN 61000-4-4
RF Conducted disturbance:	EN 50141
RF Field susceptibility:	EN 50140

Environmental

Operating temperature:	0°C to +70°C
Storage temperature:	-25°C to +85°C
Relative humidity:	Non-condensing 5% - 95%

Physical

Case material/finish: Clear anodised, ventilated aluminium cassette with cooling cutouts and front or rear heat sinks as applicable.
DIN 41494 part 5 compatible

* EN60950 and UL certified

EN60950

AC-DC

PK Series: TRIVOLT

Output specifications

PK60	V1	Version A: V2,V3	Version B: V2,V3
Output voltage:	5V	±12-15V	±12-15V
Output adjustment range:	4,5-5,5V	-	-
Output current:	0-6A	±0-1A	+2A/-0-0,5A
Ripple:	<40mV _{PP}	<3mV _{PP}	<3mV _{PP}
Line regulation (100% I _{OUT}): Δ iV _{OUT}	<0,2%	<0,02%	<0,02%
Load regulation static (10...90% I _{OUT}): Δ iV _{OUT}	<0,2%	<0,2% (0,75%)	<0,5% (0,75%)
Transient response (10...90% I _{OUT}):	1ms	10ms	10ms
Switching frequency, converter type:		20-50kHz flyback converter	
Current limit:	>6,5A	>±1,1A	>2,1A/0,6A
Short circuit protection:Short circuit protection:		continuous, automatic restart	
Overvoltage protection (OVP):	6-6,7V	-	-
Powerfail Signal (at full load) >6ms before V _{OUT} :	<4,8V	-	-
Temperature-Coefficient/°C:		0,02%	
Voltage compensation with SENSE max. _{NOTE1} :	0,5V	-	-
Derating:		1,6W/°C above 45°C	

PK120	V1	V2,V3
Ausgangsspannung:	5V	±12-15V
Output adjustment range:	4,5-5,5V	-
Output current:	0-12A	0-2A
Ripple:	<40mV _{PP}	<20mV _{PP}
Line regulation (100% I _{OUT}): Δ iV _{OUT}		<0,02%
Load regulation static (10...90% I _{OUT}): Δ iV _{OUT}		<0,2%
Transient response (10...90% I _{OUT}):	<0,2ms	<0,5ms
Switching frequency, converter type:		25-100kHz flyback/forward converter
Current limit:	>12,5A	>2,2A
Short circuit protection:Short circuit protection:		continuous, automatic restart
Overvoltage protection (OVP):	5,5-6,0V	-
Powerfail Signal (at full load) >6ms before V _{OUT} :	<4,8V	-
Temperature-Coefficient/°C:		0,02%
Voltage compensation with SENSE max. _{NOTE1} :	0,5V	-
Derating:		4W/°C above 55°C

PK125	V1	V2	V3
Ausgangsspannung:	5V	12V	-12V
Output adjustment range:	4,5-5,5V	10,8-13,2V	-10,8-13,2V
Ausgangsgleichstrom:	0-13A	0-4A	0-1A
Ripple:		<40mV _{PP}	
Line regulation (100% I _{OUT}): Δ iV _{OUT}	<0,3%	<0,2%	<0,2%
Load regulation static (10...90% I _{OUT}): Δ iV _{OUT}		<0,2%	
Transient response (10...90% I _{OUT}):	1ms	1ms	1ms
Switching frequency, converter type:		50kHz forward converter	
Current limit:	>14A	>5A	>1A
Short circuit protection:	continuous, automatic restart		
Overvoltage protection (OVP):	6,0-6,7V adjustable	-	-
Powerfail Signal (at full load) >6ms before V _{OUT} :	ACFAIL and SYSRESET in accordance with VME spec. rev D		
Temperature-Coefficient/°C:		0,05%	
Voltage compensation with SENSE max. _{NOTE1} :	0,5V	-	-
Derating:		3W/°C above 55°C	

PK250	V1	V2	V3
Ausgangsspannung:	5V	12V	-12V
Output adjustment range:	4,5-5,5V	10,8-13,2V	-10,8-13,2V
Output current:	0-30A	0-6A	0-3A
Ripple:		<40mV _{PP}	
Line regulation (100% I _{OUT}): Δ iV _{OUT}		<0,2%	
Load regulation static (10...90% I _{OUT}): Δ iV _{OUT}	<0,2%	<1%	<1%
Transient response (10...90% I _{OUT}):	1ms	2ms	2ms
Switching frequency, converter type:		50kHz halfbridge push-pull converter	
Current limit:	>31A	>6,5A	>3,5A
Short circuit protection:		continuous, automatic restart	
Overvoltage protection (OVP):	5,5-7,0V adjustable	-	-
Powerfail Signal (at full load) >6ms before V _{OUT} :	ACFAIL and SYSRESET in accordance with VME spec. rev D		
Temperature-Coefficient/°C:		0,05%	
Voltage compensation with SENSE max. _{NOTE1} :	0,5V	-	-
Derating:		6W/°C above 55°C	

PK Series: TRIVOLT

Mechanical details

PK60

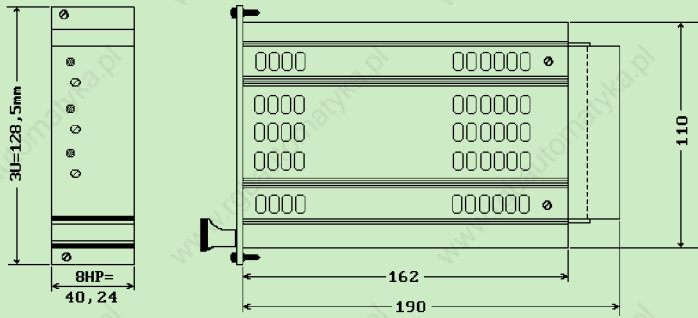

Weight: PK60: 850g

PK120, PK125, PK250

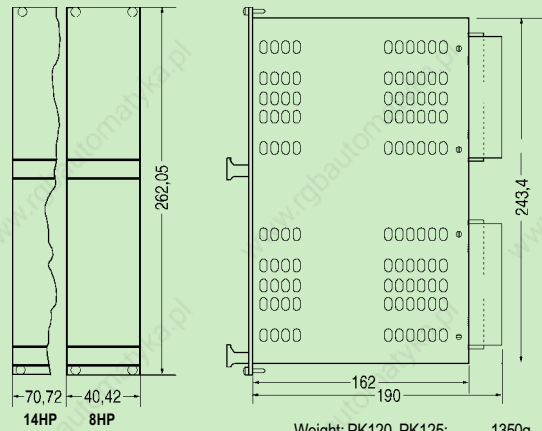

Weight: PK120, PK125: 1350g
Weight: PK250: 2500g

Pin allocation H15-connector

PN	Function	PK120
4	+5V	+5V
6	+5V	+5V
8	-Vout	-Vout
10	-Vout	-Vout
12	+SENSE	+SENSE
14	-SENSE	-SENSE
16	PF α	PF α
18	+12-15V	+12-15V
20	0V	0V
22	-12-15V	-12-15V
24	—	—
26	—	—
28	N	N
30	L	L
32	E	E

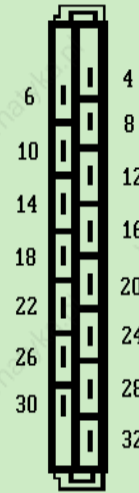

Pin allocation - H15+2HA connector

PN	Function S2	PIN	Function S1 (DIN41612 - C96)
	<i>PK125/250</i>		<i>PK125/250</i>
I	+5V	B3	AC FAIL
II	0V	C12	SYS RESET
14	+SENSE	C9	0V
16	-SENSE		
18	+12V		
20	0V (±12V)		
22	-12V		
28	N		
30	L		
32	E		



AC-DC

EC Series



MONOVOLT EC50
TRIVOLT EC50/125

ec50
ec125
ec50
ec125
ec50
ec125
ec50
ec125
ec50

AC-DC

EC-Series: MONOVOLT

Primary switched mode 50 Watt single output power supplies for use in 19" subracks to DIN41494

Features

- Reduced cost primary switched mode power supply
- Plastic coated steel cover
- Overvoltage protection (OVP)
- No load and short circuit proof
- Powerfail signal
- Coded H15 connector
- Standardized pinning



EC50 MONOVOLT Power Supplies

Ordering information

Description: Economy power supply; 3U x 8HP, 50Watt output

Type	Output	Order-code
EC-50	5V/8A	116-010188J
EC-50 with Powerfail	5V/8A	116-010189F
EC-50	12V/4A	116-010190G
EC-50	15V/3,5A	116-010192A
EC-50	24V/2,2A	116-010194F

Description: Accessories

Front panel kit with handle, idents and screws	148-010002K
Mating connector coded H15 to DIN 41612	017-010115K
Coding keys Pkt 10	017-010064F

Technical Data EC Series: Monovolt EC50

Input specification

Input voltage:	93-264VAC wide input
Input frequency:	47-63Hz
Inrush surge current limitation:	by NTC resistor
Input overvoltage protection:	by VDR
Hold up time (Nominal V_{IN} ; 100% I_{OUT}):	>20ms
Efficiency:	typ. 68-75%

Safety (Compliant with Low Voltage Directive 73/23/EEC)

Certified to, or meets the requirement of: EN60950, IEC 950, VDE 0805, EN41003 (EC100)

EMC (Compliant with EMC Directive 89/336/EEC)

Emmissions:	EN 55022/B (0,15-30MHz)
Immunity:	EN50082-2
Electro Static Discharge:	EN61000-4-2
Electrical fast transients/Burst:	EN61000-4-4
RF Conducted disturbance:	EN50141
RF Field susceptibility:	EN50140

Environmental

Operating temperature:	0°C to +70°C
Storage temperature:	-25°C to +85°C
Relative humidity:	Non-condensing 5% - 95%

Physical

Case material/finish: ventilated plastic coated steel cassette with cooling cutouts and rear heat sink.
DIN 41494 part 5 compatible

* EN 60950 certified

Output specifications

EC50	V1	V1	V1	V1
Output voltage:	5V	12V	15V	24V
Adjustment range:	4,5-5,5V	10,8-13,2V	13,5-16,5V	21,6-26,4V
Output current:	0-8A	0-4A	0-3,5A	0-2,2A
Ripple:			>40mV _{pp}	
Line regulation (100% I_{OUT}): ΔiV_{OUT}			>0,2%	
Load regulation static (10...90% I_{OUT}): ΔiV_{OUT}			>1%	
Transient response (10...90% I_{OUT}):			>1ms	
Switching frequency, converter type::		25kHz Flyback converter		
Current limit:	>8,8A	>4,4A	>3,8A	>2,4A
Overvoltage protection (OVP):		continuous, automatic restart		
Overvoltage protection (OVP):	6-6,7V	15,5-18V	17-19,5V	27-32V
Powerfail Signal (at full load) >6ms before V_{OUT} :	>6ms (@110VAC); >80ms (@220VAC) before $V1 < 4,8VAC$			
Temperature-Coefficient/°C:		0,05%		
Voltage compensation with SENSE max,NOTE1:		-		
Derating:		1,2W/°C above 45°C		

AC-DC

EC-Series: MONOVOLT

Mechanical Details

EC50

Weight: EC50 650g

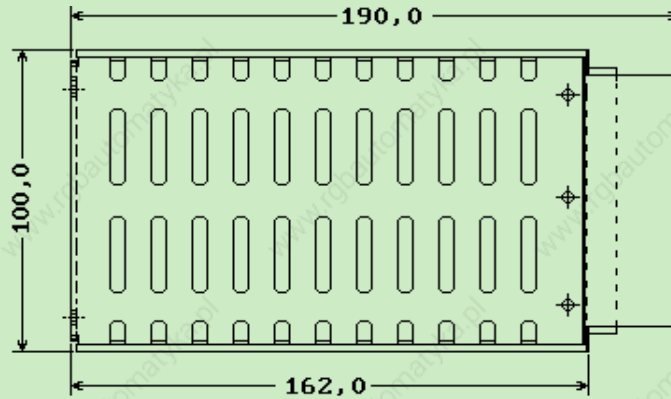

EC50 Front panels

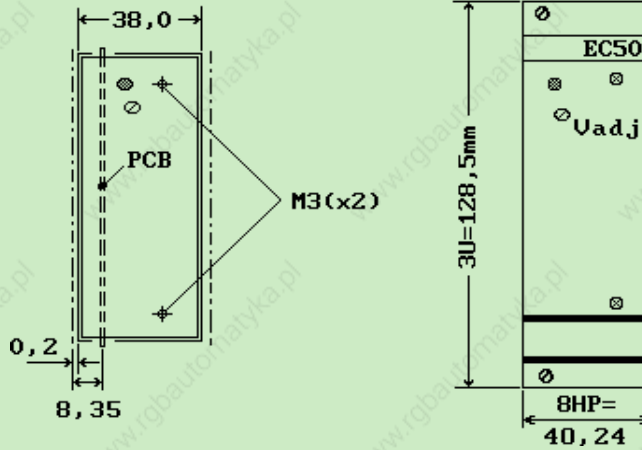

Pin allocation - H15 Connector

PIN	Function EC50
4	+Vout
6	+Vout
8	-Vout
10	-Vout
12	-
14	-
16	PF Q
18	—
20	—
22	—
24	—
26	—
28	N
30	L
32	E

H15 Connector



EC-Series: TRIVOLT

Primary switched mode 50 or 125 Watt triple power supplies for use in 19" subracks to DIN41494

Features

- Economy priced alternative of PK series
- Compact, rugged design
- Safety to approvals to UL, cUL and EN60950
- Overvoltage (OVP) and short circuit protected
- Powerfail signal
- Coded H15 connector
- Standardized pinning



EC 50, EC 125 TRIVOLT Power Supplies

Ordering information

Description: TRIVOLT EC50; 3Ux 8HP, 50 Watt Output

Type	Outputs	Order-Code	
		without Powerfail	with Powerfail
EC50-A	5V/5A, +12V/1,8A, -12V/0,4A	116-010130J*	116-010131F*
EC50-B	5V/5A, +15V/1,4A, -15V/0,3A	116-010183B*	116-010184K*
EC50-C	5V/5A, ±15V/0,8A	116-010186D*	116-010187A*
EC50-D	5V/5A, ±12V/1A	116-010217B*	116-010218K*

Description: TRIVOLT EC125; 3U x 14HP, 6U x 8HP, 125 Watt Output

Type	Outputs	Order-Code	
		without Powerfail	with Powerfail
EC125, 3U	5V/13A, +12V/4A, -12V/1A	116-010214L	-
EC125, 6U	5V/13A, +12V/4A, -12V/1A	116-010185G	-

Description: EC Series; accessories

	Order code
Frontpanel kit with handle, idents and screws: EC50	148-010002K
3U Frontpanel kit with handle, idents and screws: EC125	148-010005A
6U Frontpanel kit with handle, idents and screws: EC125	148-010003G
Mating connector coded H15 to DIN 41612	017-010115K
Coding keys Pkt 10	017-010064F

Technical Data EC Series: TRIVOLT EC50, EC125

Input Specifications

Input voltage AC-DC:	93-264VAC wide input EC50, 115/230VAC switchable EC125
Input frequency:	47-63Hz
Inrush surge current limitation:	by NTC-resistor
Input overvoltage protection:	by VDR
Hold up time (Nominal V _{IN} ; 100% I _{OUT}):	>20ms
Efficiency:	typ. >70%

Safety (Compliant with Low Voltage Directive 73/23/EEC)

Safety according: EN60950, IEC 950, VDE 0805

EMC (Compliant with EMC Directive 89/336/EEC)

Emmissions:	EN 55022/B (0,15-30MHz)
Immunity:	EN50082-2
Electro Static Discharge:	EN61000-4-2
Burst:	EN61000-4-4
RF Conducted disturbance:	EN50141
RF Field susceptibility:	EN50140

Environmental

Operating temperature:	0°C to +70°C
Storage temperature:	-25°C to +85°C
Relative humidity:	Non-condensing 5% - 95%

Physical

Case material/finish: zinc coated steel cover with cooling cutouts and rear heat sink. DIN 41494 part 5 compatible5

* EN 60950 certified

AC-DC

EC Series: TRIVOLT

Output Specifications

TRIVOLT EC50A	V1	V2	V3
Output voltage:	5V	+12V	-12V
Adjustment range:	4,5-5,5V	~V1	fixed
Output current:	0-5A	0-1,8A	0-0,4A
Output current at single loading:	8A <small>NOTE 1</small>	4A <small>NOTE 1</small>	0,8A
Ripple:	>40mV _{PP}	>40mV _{PP}	>10mV _{PP}
Line regulation (100% I _{OUT}): Δ iV _{OUT}		<0,2%	
Load regulation static (10...90% I _{OUT}): Δ iV _{OUT}	>1%	>5% <small>NOTE 2</small>	>0,5%
Transient response (10...90% I _{OUT}):		>1ms	
Switching frequency, converter type:		50kHz flyback converter	
Current limit:	>6A(>9A <small>NOTE 3</small>)	>2,2A(>4,5A <small>NOTE 3</small>)	>0,8A
Short circuit protection:		continuous, automatic restart	
Overvoltage protection (OVP):	6-6,7V	-	-
Temperature-coefficient/°C:		0,05%	
Voltage compensation with SENSE max.:		-	
Derating:		1,5W/°C above 45°C	

TRIVOLT EC50B	V1	V2	V3
Output voltage:	5V	+15V	-15V
Adjustment range:	4,5-5,5V	~V1	fixed
Output current:	0-5A	0-1,4A	0-0,3A
Output current at single loading:	8A <small>NOTE 1</small>	3A <small>NOTE 1</small>	0,6A
Ripple:	<40mV _{PP}	<40mV _{PP}	<10mV _{PP}
Line regulation (100% I _{OUT}): Δ iV _{OUT}		<0,2%	
Load regulation static (10...90% I _{OUT}): Δ iV _{OUT}	<1%	<3% <small>NOTE 2</small>	<0,5%
Transient response (10...90% I _{OUT}):		<1ms	
Switching frequency, converter type:		50kHz flyback converter	
Current limit:	>6A(>9A <small>NOTE 3</small>)	>1,7A(>3,5A <small>NOTE 3</small>)	>0,6A
Short circuit protection:		continuous, automatic restart	
Overvoltage protection (OVP):	6-6,7V	-	-
Powerfail Signal (at full load) :		>6ms (@110VAC); >80ms (@220VAC) before V1 <4,8V	
Temperature-coefficient/°C:		0,05%	
Voltage compensation with SENSE max.:		-	
Derating:		1,5W/°C above 45°C	

TRIVOLT EC50C	V1	V2, V3
Output voltage:	5V	±15V
Adjustment range:	4,5-5,5V	fixed
Output current:	0-5A	0-0,8A
Output current at single loading:	8A <small>NOTE 1</small>	1A
Ripple:	<40mV _{PP}	<10mV _{PP}
Line regulation (100% I _{OUT}): Δ iV _{OUT}		<0,2%
Load regulation static (10...90% I _{OUT}): Δ iV _{OUT}	<1%	<0,5%
Transient response (10...90% I _{OUT}):		<1ms
Switching frequency, converter type:		50kHz flyback converter
Current limit:	>6A(>9A <small>NOTE 3</small>)	>1,1A
Short circuit protection:		continuous, automatic restart
Overvoltage protection (OVP):	6-6,7V	-
Powerfail Signal (at full load):		>6ms (@110VAC); >80ms (@220VAC) before V1 <4,8V
Temperature-coefficient/°C:		0,05%
Voltage compensation with SENSE max.:		-
Derating:		1,5W/°C above 45°C

EC Series: TRIVOLT

Output Specifications

TRIVOLT EC50D	V1	V2, V3
Output voltage:	5V	±12V
Adjustment range:	4,5-5,5V	fixed
Output current:	0-5A	0-0,8A
Output current at single loading:	8A <small>NOTE 1</small>	1A
Ripple:	<40mV _{PP}	<10mV _{PP}
Line regulation (100% I _{OUT}): Δ iV _{OUT}		<0,2%
Load regulation static (10...90% I _{OUT}): Δ iV _{OUT}	<1%	<0,5%
Transient response (10...90% I _{OUT}):		<1ms
Switching frequency, converter type:		50kHz flyback converter
Current limit:	>6A (>9A <small>NOTE 3</small>)	>1,1A
Short circuit protection:		continuous, automatic restart
Overvoltage protection (OVP):	6-6,7V	-
Powerfail Signal (at full load)	>6ms (@110VAC); >80ms (@220VAC) before V1 <4,8V	
Temperature-coefficient/°C:	0,05%	
Voltage compensation with SENSE max.:	-	
Derating:	1,5W/°C above 45°C	

Note 1. 60 Seconds max

Note 2. I₂ = 0,1-4 x I_{OUT}

Note 3. Single load

Note 4. V2/V3 output EC50 C+D linear regulated

TRIVOLT EC125	V1	V2	V3
Output voltage:	5V	+12V	-12V
Adjustment range:	4,5-5,5V	10,8-13,2V	-10,8 to -13,2V
Output current:	0-13A	0-4A	0-1A
Ripple:	<40mV _{PP}	<40mV _{PP}	<10mV _{PP}
Line regulation(100% I _{OUT}): Δ iV _{OUT}	<0,3%	<0,2%	<0,2%
Load regulation static (10...90% I _{OUT}): Δ iV _{OUT}		<0,2%	
Transient response (10...90% I _{OUT}):		<1ms	
Switching frequency, converter type:		100kHz forward converter	
Current limit:	>14A	>5A	>1A
Short circuit protection:		continuous, automatic restart	
Overvoltage protection (OVP):	6-6,7V	-	-
Powerfail Signal:		-	
Temperature-coefficient/°C:		0,05%	
Voltage compensation with SENSE max.:	0,5V	-	-
Derating:		2,5W/°C above 45°C	

EC Series: TRIVOLT

Mechanical Details

TRIVOLT EC50

Weight EC50: 650g

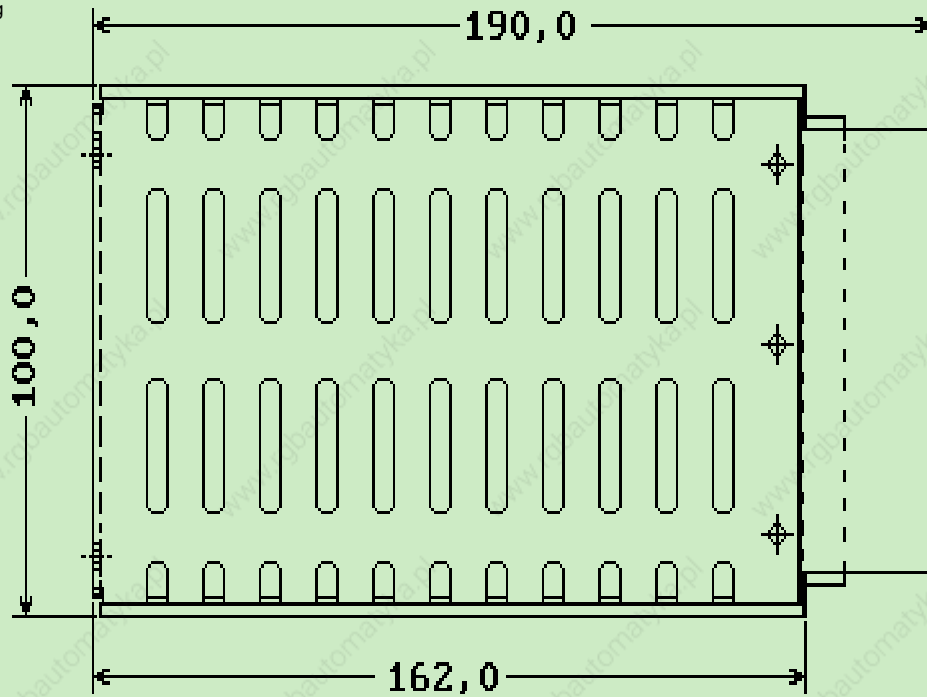

Front panel kit

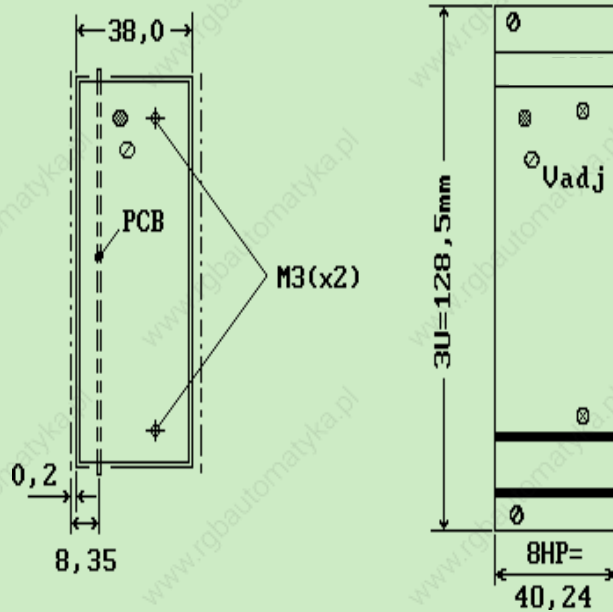

EC-Series: TRIVOLT

Mechanical Details

TRIVOLT EC125

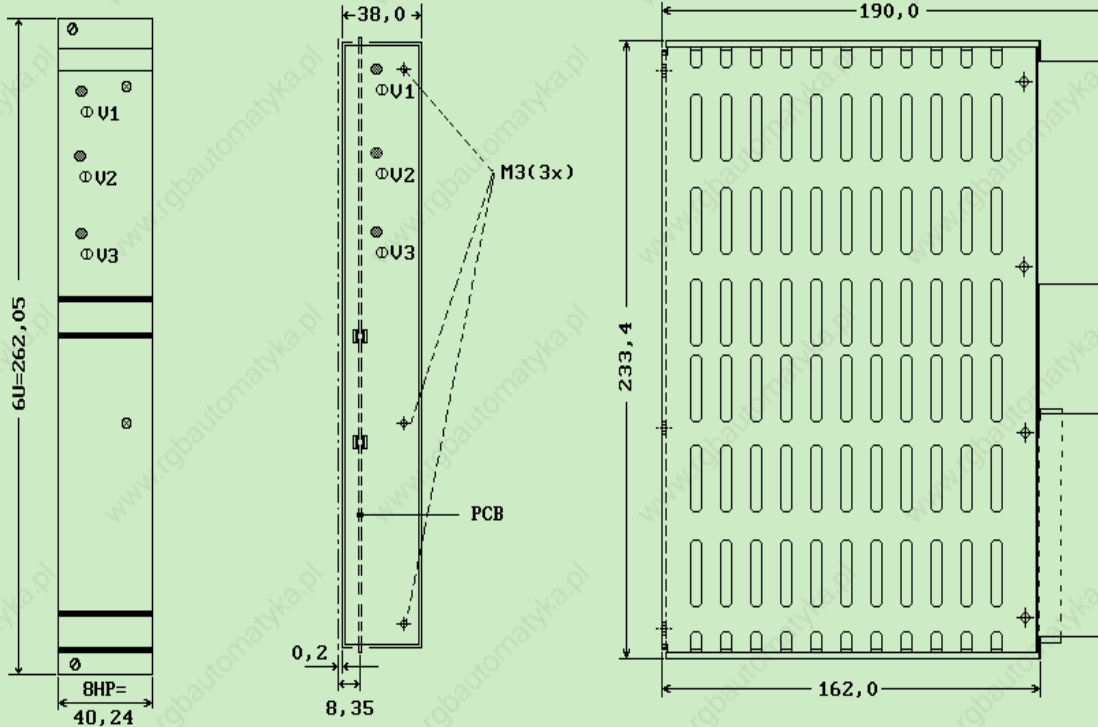

Front panel kit

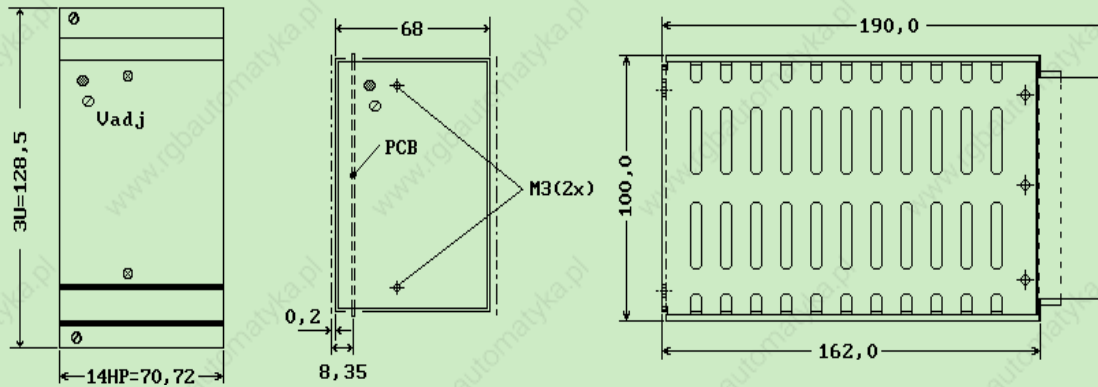

Weight EC125: 1350g

Pin allocation H15-Connector

PIN	Function EC50 Trivolt	Function EC125 Trivolt
4	+Vout	+Vout
6	+Vout	+Vout
8	-Vout	-Vout
10	-Vout	-Vout
12	NC	+Sense
14	NC	-Sense
16	PF Q	-
18	+V2	+V2
20	GND V2, V3	GND V2, V3
22	-V3	-V3
24	NC	NC
26	NC	NC
28	N	N
30	L	L
32	E	E

H15 Connector

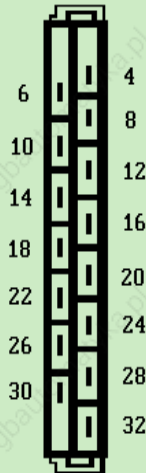

AC-DC

Cased Power Supplies: PO500-3 with active PFC

The PO Series is a range of power factor corrected cased power supplies producing 500 Watts output power and three outputs for complex industrial computer systems, i.e. VMEbus based systems

Features

- Power Factor Correction (PFC), power factor >0,97
- 110-230VAC wide input
- Meets UL 1950, cUL and EN 60 950 safety
- ACFAIL and SYSRESET VME specific signals
- Connection via universal screw terminals
- Completely cased, including cooling fan
- Special versions available (minimum order quantity 25 pieces)

Ordering information

Description: Trivolt power supply; 500 Watt output

Model	Outputs	Order code
PO500-3	5V/75A, +12V/8A, -12V/3A	137-010000L
PO500-3 Ext. on/off	5V/75A, +12V/8A, -12V/3A	137-010001H



PO500-3 with active PFC

Technical Data PO Series: Trivolt

Input specification

Input voltage:	94-230VAC wide input
Input frequency:	47-63Hz
Input overvoltage protection:	by VDR
Hold up time (Nominal V_{IN} ; 100% I_{OUT}):	>20ms at 230VAC
Efficiency:	typ. 80%

Safety (Compliant with Low Voltage Directive 73/23/EEC)

Certified to:	EN60950, IEC 950, UL1950, cUL
---------------	-------------------------------

EMC (Compliant with EMC Directive 89/336/EEC)

Emmissions: EN 55022/B (0,15-30MHz); EN 55022/B (30-1000MHz)	
Immunity:	EN 50082-2
Electro Static Discharge:	EN 61000-4-2
Electrical fast transients/Burst:	EN 61000-4-4
RF Conducted disturbance:	EN 50141
RF Field susceptibility:	EN 50140
Surge susceptibility:	EN 61000-4-5
Harmonic distortion:	EN 61000-3-2

Environmental

Operating temperature:	0°C to +65°C
Storage temperature:	-25°C to +85°C
Relative humidity:	Non-condensing 5% - 95%

Physical

Dimensions: PO500-3	127mm wide x 63mm high x 320mm deep
Weight: PO500-3	3000g
Case material/finish:	Clear anodised aluminium

Cased Power Supplies: PO500-3 with active PFC

Output specifications

PO500	V1	V2	V3
Output voltage:	5V	12V	-12V
Adjustment range:	4,5-5,5V	11-13V	fixed
Output current:	75A	8A	3A
Ripple:		<50mV _{PP}	
Noise:		<100mV _{PP}	
Line regulation (100% I _{OUT}): Δ iV _{OUT}		<0,2%	
Load regulation static (10...90% I _{OUT}): Δ iV _{OUT}	<0,5%	<0,2%	Typ. <0,2% (20-90%I _{OUT})
Current limit:	>75,1A	>8,1A	>3,1A
Short circuit protection:		yes	
Over voltage protection (OVP):	6,0V (5,5-6,75V adjustable)	14,4V (fixed)	-
Powerfail Signal (at full load) >6ms before V _{OUT} :	ACFAIL and SYSRESET in accordance with VME specification, Rev C1		
External On/Off:	by jumper (closed = off, open = on), isolated		
Temperature coefficient/°C:		<0,05%	
Voltage compensation with SENSE max _{X,ANM 1} :	0,5V	-	-
Derating:		12,5W/°C above 50°C	

Mechanical Details

Pin allocation

Screw block	PIN	Function
5 Volt	I	+V1
	II	-V1
X200	1	-V3
	2	GND V2/V3
	3	+V2
Screw block	PIN	Function
X101	1	Ext. On/Off
	2	SYSRESET*
	3	NC
	4	*SIGNAL GND
	5	Ext. On/Off
	6	AC-FAIL
	7	-SENSE V1
	8	+SENSE V1
Screw block	PIN	Function
X1	1	E (Earth)
	2	N (Neutral)
	3	L (Live)

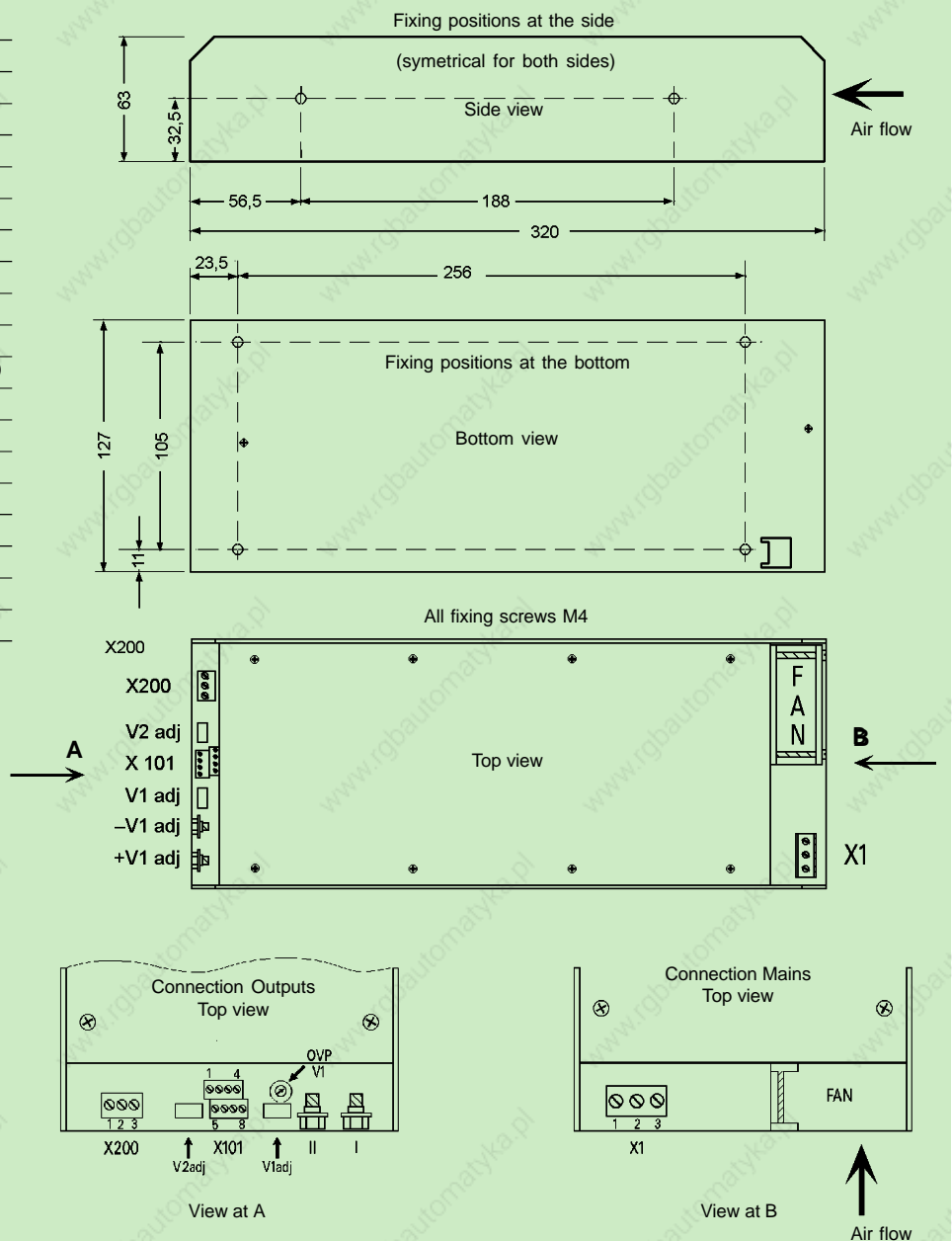

AC-DC

TPS-Series: 1-3 Outputs and active PFC

Primary switched mode power supplies with side heat sinks for use in 19" subracks to DIN41494, 100 to 150 Watt output power.

Features

- Power Factor Correction (PF>0,97)
- Universal input
- Compact, rugged design
- Power share on outputs 1 and 2
- CE marked for compliance to EMC and Low Voltage Directives
- Safety to approvals to UL, cUL and EN60950

General

The Danica TPS 3102 and TPS 3152 power supply series are equipped with Power Sharing, so two or more units can operate in parallel and redundant. Power fail signal (PWF) and Remote sense* (* single output only) are standard.

Order information

Description: EA-TPS3102-1, EA-TPS3102-3, EA-TPS3152-1, EA-TPS3152-3

Description: EA-TPS3102 100W Power supply

Type	Outputs	Art. Nb.
EA-TPS 3102-1-05	5V/20A	17120107
EA-TPS 3102-1-12	12V/8A	17120108
EA-TPS 3102-1-24	24V/4A	17120109
EA-TPS 3102-1-48	48V/2A	17120110
EA-TPS 3102-3-00	V1:5V/20A, V2: 12V/8A, V3: 12V/2,5A <small>Note 1</small>	17120111

Note 1) Maximum output power 100 W

Description: EA-TPS3152 150W Power supply

EA-TPS 3152-1-05	5V/30A	17120112
EA-TPS 3152-1-12	12V/12A	17120113
EA-TPS 3152-1-24	24V/6A	17120114
EA-TPS 3152-1-48	48V/3A	17120115
EA-TPS 3152-3-00	V1:5V/30A, V2: 12V/12A, V3: 12V/2,5A <small>Note 2</small>	17120116

Note 2) Maximum output power 150 W

Dimensions

TPS 3102

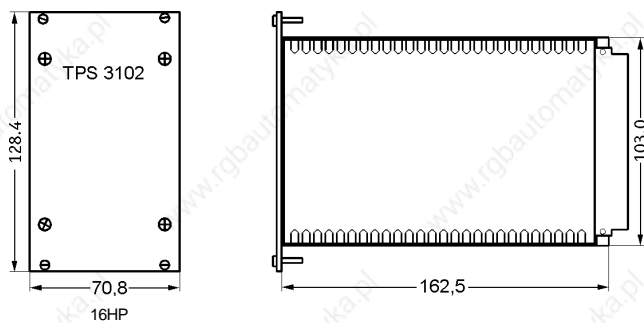

TPS 3152

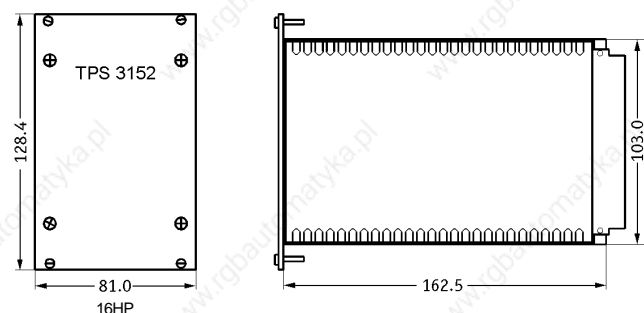

TPS3152

Technical Data of TPS3102-1, TPS3102-3, TPS3152-1, TPS3152-3

Input Data

Input voltage:	93-264VAC
Input frequency:	44-65Hz
Inrush current limit:	Minimal
Input overvoltage protection:	VDR
Hold up time (Nominal V_{IN} ; 100% I_{OUT}):	20ms
Efficiency:	typ. 75-85%

Safety (Compliant with Low Voltage Directive 73/23/EEC)

Safety according: EN60950

EMC (Compliant with EMC Directive 89/336/EEC)

Emmissions: EN 55022/B (0,15-30MHz); EN 55022/B (30-1000MHz)

Environmental

Operating temperature:	0°C to +70°C / Derating >55°C 5W/°C
Storage temperature:	-25°C to +85°C (-45°C to +85°C)
Relative humidity:	max. 90% non-condensing

Physical

Dimensions: EA-TPS3102 19"-Rack	3U x 14HP x 160mm (70,8mm wide x 128,5mm high)
Dimensions: EA-TPS3152 19"-Rack	3U x 16HP x 160mm (81,0mm wide x 128,5mm high)
Weight: EA-TPS3102	1100g
Weight: EA-TPS3152	1100g
Case material/finish:	ventilated aluminium with side heat sinks. DIN 41494 part 5 compatible

Pin allocation H15-connector

Single Output



- 4 NC
- 6 + SENSE
- 8 - SENSE
- 10 + OUT
- 12 + OUT
- 14 + OUT
- 16 RTN
- 18 RTN
- 20 RTN
- 22 SHARE
- 24 Power fail
- 26 NC
- 28 Input AC N
- 30 Input AC L
- 32 GND PE

Triple Output



- 4 + Output 3
- 6 + Output 2
- 8 - Output 3 RTN
- 10 + Output 1
- 12 + Output 1
- 14 + Output 1
- 16 Output 1&2 RTN
- 18 Output 1&2 RTN
- 20 Output 1&2 RTN
- 22 SHARE
- 24 Power fail
- 26 NC
- 28 INPUT AC N
- 30 INPUT AC L
- 32 GND PE

TPS-Series: 1-3 Outputs and active PFC

Output specifications

EA-TPS3102-1	V1	V1	V1	V1
Output voltage:	5V	12V	24V	48V
Adjustment range:	fixed			
Output current:	20A	8A	4A	2A
Ripple:	<50mV _{PP}	<50mV _{PP}	<50mV _{PP}	<100mV _{PP}
Current limit:	22-32A	10-15A	5-8A	2,5-5,0A
Switching frequency, converter type:	67kHz, flyback converter			
Over voltage protection (OVP):	5,8V	13V	27V	54V
Line regulation (100% I _{OUT}): Δ i _{VOUT}				0,1%
Load regulation static (10...90% I _{OUT}): Δ i _{VOUT}				0,5%
Powerfail Signal (at full load) >6ms before V _{OUT} :				yes
Temperature coefficient/°C:				0.02%
Voltage compensation with SENSE max.:				0,5V
Derating: above 55°C				5,0W/°C

EA-TPS3102-3*	V1	V2	V3
Output voltage:	5V	12V	12V
Adjustment range:	fixed		
Output current:	20A	8A	2,5A
Ripple:	50mV _{PP}		
Current limit:	22-32A	10-15A	2,7-4,0A
Switching frequency, converter type:	67kHz, flyback converter		
Over voltage protection (OVP):	5,8V	-	-
Line regulation (100% I _{OUT}): Δ i _{VOUT}	0,1%	0,1%	0,1%
Load regulation static (10...90% I _{OUT}): Δ i _{VOUT}	1,5%	1,0%	1,0%
Powerfail Signal (at full load) >6ms before V _{OUT} :	yes		
Temperature coefficient/°C:	0.02%		
Voltage compensation with SENSE max.:	0,5V		
Derating: above 55°C	5,0W/°C		

* Max output power 100W

EA-TPS3152-1	V1	V1	V1	V1
Output voltage:	5V	12V	24V	48V
Adjustment range:	4,8-5,5V	11-13V	22-26V	22-26V
Output current:	30A	12A	6A	3A
Ripple:	<50mV _{PP}	<50mV _{PP}	<50mV _{PP}	<100mV _{PP}
Current limit:	32-45A	13-18A	7-12A	3,2-4,0A
Switching frequency, converter type:	67kHz, flyback converter			
Over voltage protection (OVP):	5,8V	15V	28V	52V
Line regulation (100% I _{OUT}): Δ i _{VOUT}				0,1%
Load regulation static (10...90% I _{OUT}): Δ i _{VOUT}				0,5%
Powerfail Signal (at full load) >6ms before V _{OUT} :				yes
Temperature coefficient/°C:				0,02%
Voltage compensation with SENSE max.:				0,5V
Derating: above 40°C				3,75W/°C

EA-TPS3152-3*	V1	V2	V3
Output voltage:	5V	12V	12V
Adjustment range:	4,8-5,5V	11-13V	14-16V
Output current:	30A	12A	2,5A
Ripple:	<50mV _{PP}		
Current limit:	32-45A	13-18A	2,7-4,0A
Switching frequency, converter type:	67kHz, flyback converter		
Over voltage protection (OVP):	5,8V	13V	-
Line regulation (100% I _{OUT}): Δ i _{VOUT}			0,1%
Load regulation static (10...90% I _{OUT}): Δ i _{VOUT}	2%	1,0%	1%
Powerfail Signal (at full load) >6ms before V _{OUT} :	yes		
Temperature coefficient/°C:	0,02%		
Voltage compensation with SENSE max.:	0,5V		
Derating: above 40°C	3,75W/°C		

* Max output power 150W

TPS-4000: Single Output with active PFC, 550W

Primary switched mode power supplies with side heat sinks for use in 19" subracks to DIN41494, with 550 Watt output power.

Features

- Power Factor Correction (PF>0,97)
- Universal input
- N+1, Hot pluggable, (6U x 16HP)
- Remote Sense
- Power share with parallel operating units
- CE marked for compliance to EMC and Low Voltage Directives
- Safety to approvals to UL, cUL and EN60950
- Available as battery charger

Ordering information

Model: EA-TPS 4000

Ordering information

Model: EA-TPS4000 550W Power Supply

EA-TPS 4000-12	12V/35A	17120119
EA-TPS 4000-24	24V/20A	17120120
EA-TPS 4000-48	48V/10A	17120121

Model: EA-TPS 4000 550W Charger

EA-TPS 4000-28	28,3V/20A	17120122
EA-TPS 4000-54	54,5V/10A	17120123

Dimensions TPS 4000

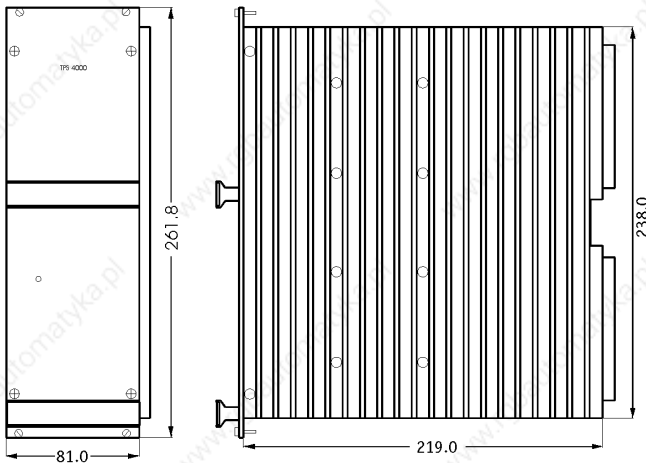

Technical Data

EA-TPS 4000	V1	V1	V1
Output Voltage:	12V	24V	48V
Ripple:		150mV _{PP}	
Output current:	35A	20A	10A
-limit:	>40A	>24A	>12A
Switching frequency:	70kHz		
Overshoot protection (OVP):	16V	32V	60V
Line regulation (100% IOUT): iVOUT	0,2%		
Load regulation (10...90% IOUT): iVOUT	0,2%		
Powerfail-Signal (at full load) >6ms before VOUT:	yes		
Temperature-coefficient/°C:	0,02%		
Remote SENSE max.:	0,5V		
Derating: above 55°C	20W/°C		

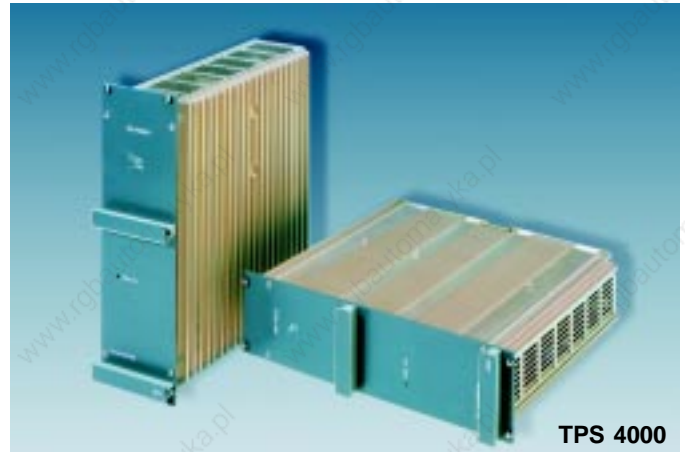

TPS 4000

Technical Data TPS4000

Input Specifications

Input Voltage:	93-264VAC
Input frequency:	44-65Hz
Inrush current limit:	<40A
Input overvoltage protection:	VDR
Hold up time (Nominal VIN; 100% IOUT):	20ms
Efficiency:	typ. 85-90%

Safety (Compliant with Low Voltage Directive 73/23/EEC)

Safety according: EN60950

EMC (Compliant with EMC Directive 89/336/EEC)

Emmissions: EN 55022/B (0,15-30MHz); EN 55022/B (30-1000MHz)

Environmental

Operating temperature:	0°C to +70°C / Derating >55°C 40W/°C
Storage temperature:	-25°C bis +85°C (-45°C bis +85°C)
Relative humidity:	max. 90% non-condensing

Physical

Dimensions: EA-TPS4000 19"-Rack	6U x 16HP x 220 (81,0mm wide x 261,8mm high)
Weight: EA-TPS4000	3600g
Case material/finish:	ventilated aluminium with side heat sinks. DIN 41494 part 5 compatible

Pin allocation H15-connector

Upper



- 4 Input AC N
- 6 Input AC N
- 8 Input AC L
- 10 Input AC L
- 12 Shutdown
- 14 Shutdown
- 16 NC
- 18 NC
- 20 Internal use
- 22 Internal use
- 24 NC
- 26 NC
- 28 NC
- 30 Share
- 32 GND PE

Lower



- 4 -OUT
- 6 -OUT
- 8 -OUT
- 10 -OUT
- 12 - Sense
- 14 + Sense
- 16 +OUT
- 18 +OUT
- 20 +OUT
- 22 +OUT
- 24 NC
- 26 NC
- 28 Battery test
- 30 NC
- 32 GND PE

TPS-5000: Single Output with active PFC, 1200W

Primary switched mode power supplies with side heat sinks for use in 19" subracks to DIN41494, with 1200 Watt output power.

Features

- Power Factor Correction (PF>0,97)
- Universal input
- N+1, Hot plugable
- Power share with parallel operating units
- CE marked for compliance to EMC and Low Voltage Directives
- Safety to approvals to UL, cUL and EN60950
- Available as battery charger

Ordering information

Model: EA-TPS 5000



TPS 5000

Ordering information

Model: EA-TPS5000 1200W Power supply

EA-TPS 5000-24	24V/40A	17120124
EA-TPS 5000-48	48V/20A	17120125

Model: EA-TPS5000 1200W Charger

EA-TPS 5000-28	28,3V/40A	17120126
EA-TPS 5000-54	54,5V/20A	17120127

Dimensions

TPS 5000

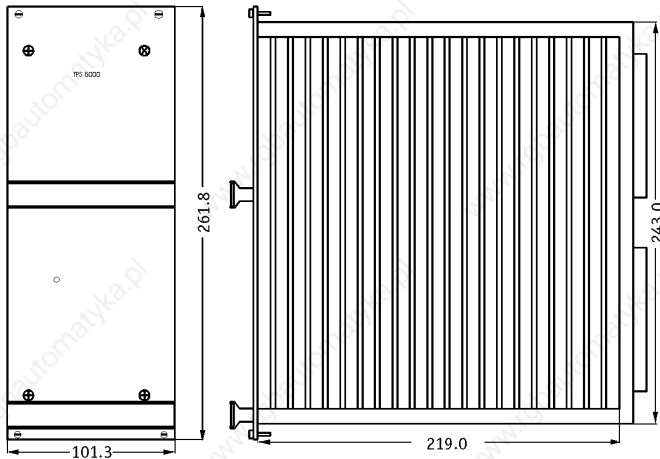

Technical Data

EA-TPS 5000	V1	V1
Output voltage:	24V	48V
Ripple:	100mV _{PP}	
Output current:	40A	20A
Current limit:	>44A	>22A
Switching frequency:		70kHz
Overvoltage protection (OVP):	32V	64V
Line regulation (100% IO _{UT}): iV _{OUT}		0,2%
Load regulation (10...90% IO _{UT}): iV _{OUT}		0,2%
Powerfail-Signal (at full load) >6ms before V _{OUT} :		yes
Temperature-coefficient/°C:		0,02%
Remote SENSE max.:		0,5V
Derating: above 55°C		40W/°C

Technical Data TPS 5000

Input Specifications

Input Voltage:	176-264VAC
Input frequency:	44-65Hz
Inrush current limit:	<40A
Input overvoltage protection:	VDR
Hold up time (Nominal V _{in} ; 100% IO _{UT}):	20ms
Efficiency:	typ. 85-90%

Safety (Compliant with Low Voltage Directive 73/23/EEC)
Safety according : EN60950

EMC (Compliant with 89/336/EEC)

Emissions: EN 55022/B (0,15-30MHz); EN 55022/B (30-1000MHz)

Environmental

Operating temperature:	0°C to +70°C / Derating >55°C 40W/°C
Storage temperature:	-45°C to +85°C
Relative humidity:	max. 90% non-condensing

Physical

Dimensions: EA-TPS 5000 19"-Rack	6U x 20HP x 219 (101,3mm wide x 261,8mm high)
Weight: EA-TPS 5000	4800g
Case material/finish:	ventilated aluminium with side heat sinks. DIN41494, part 5 compatible

Pin allocation H15-connector

Upper



- 4 Input AC N
- 6 Input AC N
- 8 Input AC L
- 10 Input AC L
- 12 Shutdown
- 14 Shutdown
- 16 NC
- 18 NC
- 20 Internal use
- 22 Internal use
- 24 NC
- 26 NC
- 28 NC
- 30 Share
- 32 GND PE

Lower



- 4 -OUT
- 6 -OUT
- 8 -OUT
- 10 -OUT
- 12 - Sense
- 14 + Sense
- 16 +OUT
- 18 +OUT
- 20 +OUT
- 22 +OUT
- 24 NC
- 26 NC
- 28 Battery test
- 30 NC
- 32 GND PE

TPS-5500: Single Output with active PFC, 1800W

Primary switched mode power supplies with side heat sinks for use in 19" subracks to DIN41494, with 1800 Watt output power.

Features

- Power Factor Correction (PF>0,97)
- Wide input range 176-264VAC
- N+1, Hot pluggable, (6U, 16HP x 345mm)
- Power share with parallel operating units
- Safety according EN60950, UL, CUL
- CE marked for compliance to EMC and Low Voltage Directives
- Available as battery charger

Ordering information

Model: EA-TPS5500



TPS 5500

Ordering information

Model: EA-TPS5500 1800W Power supply

EA-TPS 5500-48	48V/30A	17120130
----------------	---------	----------

Dimensions

TPS 5500

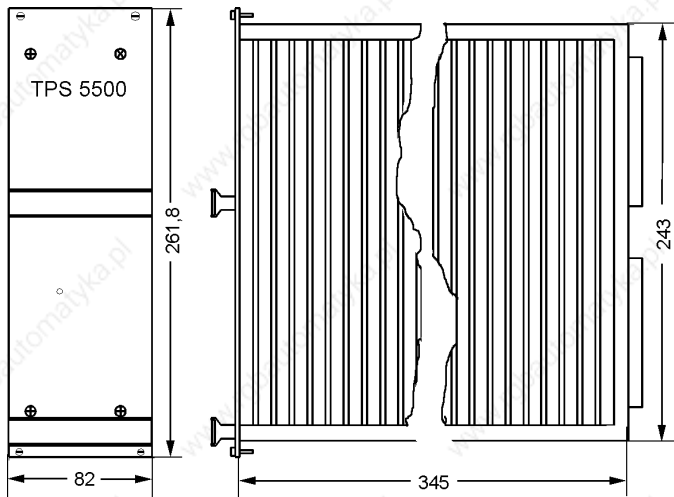

Technical Data

EA-TPS 5500	V1
Output voltage:	40...60V factory set: 53,5V
Ripple:	200mV _{PP}
Output current:	0...30A
Current limit:	30A, max. 33A, V/A
Switching frequency:	70kHz
Overshoot protection (OVP):	64V
Line regulation (100% IOUT): iVOUT	0,2%
Load regulation (10...90% IOUT): iVOUT	0,2%
Powerfail-Signal (at full load)>6ms before VOUT:	yes
Temperature-coefficient/°C	0,02%
Remote SENSE max.:	0,5V
Derating: above 55°C	40W/°C

Technical Data TPS 5500

Input Data

Input voltage:	176-264VAC
Input frequency:	44-65Hz
Inrush current limit:	20A max.
Input overvoltage protection:	VDR
Hold up time (Nominal V _{IN} ; 100% I _{OUT}):	20ms
Efficiency:	typ. 85-90%

Safety (Compliant with Low Voltage Directive 73/23/EEC)

Safety according: EN60950

EMC (Compliant with EMC Directive 89/336/EEC)

Emmissions: EN 55022/B (0,15-30MHz); EN 55022/B (30-1000MHz)

Environmental

Operating temperature:	0°C to +70°C / Derating >55°C 40W/°C
Storage temperature:	-45°C to +85°C
Relative humidity:	max. 90% non-condensing

Physical

Dimensions: EA-TPS5500 19"-Rack	6HE x 16TE x 345mm
Weight: EA-TPS5500	6000g
Case material/finish:	ventilated aluminium with side heat sinks. DIN 41494 part 5 compatible

Output Connector

H15 Connector

Lower

Upper

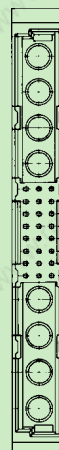

- NC
- NC
- NC
- NC
- Control-, BUS- and Sense connections
- + Output
- + Output
- Output
- Output

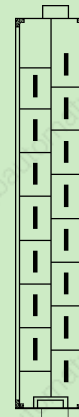

- 4 Input AC L
- 6 Input AC L
- 8 Input AC L
- 10 Input AC L
- 12 Input AC L
- 14 Input AC N
- 16 Input AC N
- 18 Input AC N
- 20 Input AC N
- 22 Input AC N
- 24 NC
- 26 NC
- 28 NC
- 30 GND PE
- 32 GND PE

TPS 6000: Single Output with active PFC, 3000W

Primary switched mode power supplies for use in 19" subracks to DIN41494, with 3000 Watt output power.

Features

- Power Factor Correction (PF>0,97)
- High efficiency (>89%)
- N+1, Hot plugable
- Power share with parallel operating units
- Safety according EN60950
- CE marked for compliance to EMC and Low Voltage Directives
- Available as battery charger

Ordering information

Model: EA-TPS 6000

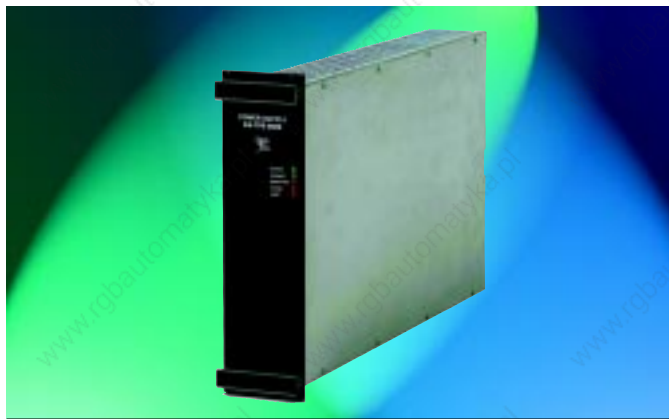

TPS6000

Ordering information: EA-TPS6000 3000W Power Supply

EA-TPS 6000-48	48V/55A	17120135
----------------	---------	----------

Dimensions TPS 6000

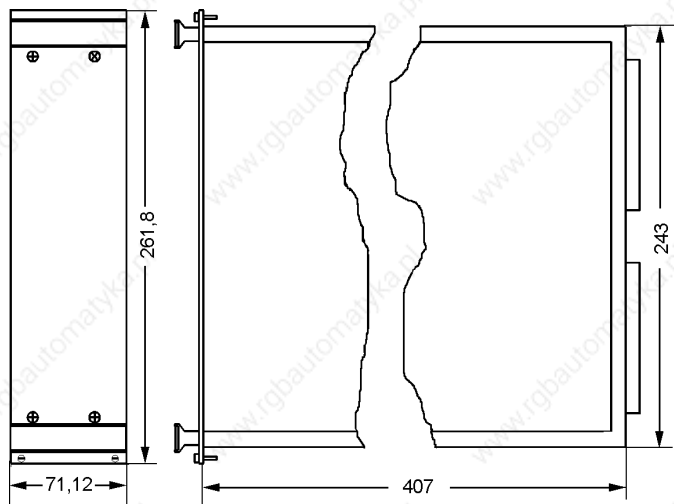

Technical Data

EA-TPS 6000	V1
Output voltage, programmable	40...60V (set to 54,5V)
Ripple:	<200mV _{pp}
Output current:	0...55A
Current limit:	55A, max. 60A, V/I
Switching frequency:	120kHz
Overvoltage protection (OVP):	typ. 67V
Line regulation (100% I _{OUT}): iV _{OUT}	0,2%
Load regulation static (10...90% I _{OUT}): iV _{OUT}	0,2%
Fault-Signals	yes
Derating:	above 40°C

Technical Data TPS6000

Input Data

Input voltage:	230VAC ±10%
Input frequency:	44-65Hz
Inrush current limit (cold at 25°C):	<30A
Input overvoltage protection:	VDR
Efficiency:	typ. >89%

Safety (Compliant with Low Voltage Directive 73/23/EEC)

Safety according:	EN60950
-------------------	---------

EMC (Compliant with EMC Directive 89/336/EEC)

Emmissions:	EN 55022/B (0,15-30MHz); EN 55022/B (30-1000MHz)
-------------	--

Environmental

Operating temperature:	0°C to +40°C / Derating >40°C
The units must be cooled by forced air.	
Storage temperature:	-25°C to +85°C
Relative humidity:	max. 90% non-condensing

Physical

Dimensions EA-TPS6000 19"-Rack	6HE x 14TE x 407mm
Weight: EA-TPS 6000	7000g
Case material/finish:	aluminium
	DIN 41494 part 5 compatible

Output Connector Lower

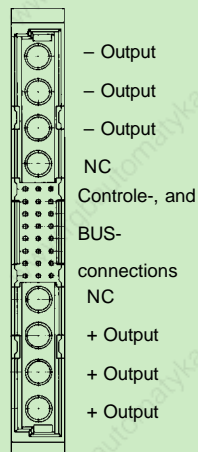

H15 Connector Upper

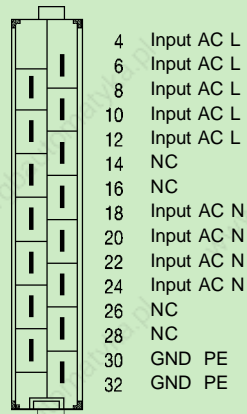

AC-DC

DC-DC

DC/DC Converter



TPS-Series
GK-Series

dc-dc
dc-dc
dc-dc
dc-dc
dc-dc
dc-dc
dc-dc
dc-dc
dc-dc
dc-dc
dc-dc
dc-dc
dc-dc

TPS Series: DC/DC-Converter for 19"-rack applications

Primary switched mode converters with side heat sinks for use in 19" subracks to DIN41494, 1-3 outputs and 100 to 250 Watts output power.

Features

- Convection cooled
- Parallel, N+1 redundant
- Wide input range
- Safety to approvals to UL, cUL and EN60950
- Inrush current limited, BTR 2511
- High MTBF
- Hot plug modular design

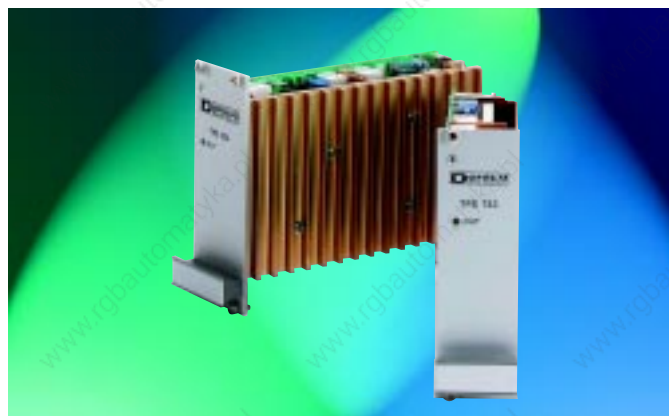

TPS-Series DC-DC converter

Ordering information

Model: TPS133, TPS264, TPS233, TPS168

TPS-Series DC-DC Converter; 100 Watt output power

TPS 133 Series

Type	Output	Article Nb.
EA-TPS 133-24-05	5V/20A	17 120 600
EA-TPS 133-24-12	12V/8,5A	17 120 601
EA-TPS 133-24-24	24V/4,5A	17 120 602
EA-TPS 133-24-48	48V/2,2A	17 120 603
EA-TPS 133-48-05	5V/20A	17 120 604
EA-TPS 133-48-12	12V/8,5A	17 120 605
EA-TPS 133-48-24	24V/4,5A	17 120 606
EA-TPS 133-48-48	48V/2,2A	

TPS-Serie DC-DC Converter; 125 Watt output power

TPS 264 Series

EA-TPS 264-24-00	V1: 5V/15A, V2:12V/6A, V3: 12V/3A	17 120 610
EA-TPS 264-48-00	V1: 5V/15A, V2:12V/6A, V3: 12V/3A	17 120 611

TPS-Serie DC-DC Converter; 150 Watt output power

TPS 233 Series

EA-TPS 233-24-05	5V/30A	17 120 620
EA-TPS 233-24-12	12V/13A	17 120 621
EA-TPS 233-24-15	15V/10A	17 120 622
EA-TPS 233-24-24	24V/6,5A	17 120 623
EA-TPS 233-24-48	48V/3,5A	17 120 624
EA-TPS 233-48-05	5V/30A	17 120 625
EA-TPS 233-48-12	12V/13A	17 120 626
EA-TPS 233-48-15	15V/10A	17 120 627
EA-TPS 233-48-24	24V/6,5A	17 120 628
EA-TPS 233-110-24	24V/6,5A	17 120 629

TPS-Serie DC-DC converter; 250 Watt output power

TPS 168 Series

EA-TPS 168-24-48	48V/5A	17 120 643
EA-TPS 168-48-24	24V/10A	17 120 646
EA-TPS 168-110-24	24V/10A	17 120 648

Technical Data TPS Series: TPS133, TPS264, TPS233, TPS168

Input Data

Input voltage DC:	24VDC (20...32V), 48VDC (40...75V), 110VDC (70...150VDC)
Inrush current limit:	BTR 2511
Input overvoltage protection:	VDR
Hold up time (Nominal V_{in} ; 100% I_{out}):	5-12ms
Efficiency:	typ. 80-90%

Safety (Compliant with Low Voltage Directive 73/23/EEC)

Isolation: Input-Output	2,5kVDC (1,5kVDC - TPS264)
Isolation: Input-Chassis	1,5kVDC
Isolation: Output-Chassis	0,5kVDC

EMC (Compliant with EMC Directive 89/336/EEC)

Emmissions:	EN 55022/B (0,15-30MHz); EN 55022/B (30-1000MHz)
-------------	--

Environmental

Operating temperature:	0°C to +70°C / Derating >55°C 40W/°C
Storage temperature:	-25°C bis +85°C (-45°C bis +85°C)
Relative humidity:	max. 90% none condensing

Physical

Dimensions: TPS133 Eurocard	3U x 8HP x 160 (40,3mm wide x 128,4mm high)
Dimensions: TPS233 Eurocard	3U x 10HP x 160 (50,5mm wide x 128,4mm high)
Dimensions: TPS264 Eurocard	3U x 14HP x 160 (70,8mm wide x 128,4mm high)
Dimensions: TPS168 Eurocard	3U x 18HP x 160 (91,1mm wide x 128,4mm high)
Weight: TPS133	700g
Weight: TPS233	900g
Weight: TPS264	900g
Weight: TPS168	900g
Case material/finish:	ventilated aluminium with side heat sinks. DIN 41494 part 5 compatible

DC-DC

TPS Series: DC/DC Converter 19"-rack applications

Output specifications

TPS 133	V1	V1	V1	V1
Output voltage:	5V	12V	24V	48V
Adjustment range:	fixed			
Output current:	20A	8,5A	4,5A	2,2A
Ripple:	<50mV _{PP}	<40mV _{PP}	<50mV _{PP}	<50mV _{PP}
Noise:	100mV			
Output current limit:	28A	11A	6A	3,3A
Switching frequency, converter type:	100kHz forward converter			
Overvoltage protection (OVP):	6,2V	15V	30V	54V
Line regulation (100% I _{OUT}): Δ i _{OUT}	0,1%	0,25%	0,08%	0,08%
Load regulation static (10...90% I _{OUT}): Δ i _{OUT}	0,1%	0,17%	0,30%	0,08%
Powerfail-Signal (at full load) >6ms before V _{OUT} :	yes			
Temperature-coefficient/°C:	0,02%			
Remote SENSE max.:	0,5V			
Derating: above 55°C	4,0W/°C			

TPS264	V1	V2	V3
Output voltage:	5V	+12V	-12V
Adjustment range:	fixed		
Output current:	15A	6,0A	3,0A
Ripple:	50mV _{PP}	100mV _{PP}	75mV _{PP}
Noise:	100mV	150mV	100mV
Output current limit:	>18A	>7,5A	>5A
Switching frequency, converter type:	100kHz forward converter		
Overvoltage protection (OVP):	6,8V	13,8V	18V
Line regulation (100% I _{OUT}): Δ i _{OUT}	0,02%	1,5%	1,25%
Load regulation static (10...90% I _{OUT}): Δ i _{OUT}	0,1%	1,5%	1,25%
Powerfail-Signal (at full load) >6ms before V _{OUT} :	yes		
Temperature-coefficient/°C:	0,02%		
Remote SENSE max.:	0,5V		
Derating: above 55°C	5W/°C		

TPS233	V1	V1	V1	V1
Output voltage:	5V	12V	24V	48V
Adjustment range:	fixed			
Output current:	30A	13A	6,5A	3,5A
Ripple:	<50mV _{PP}	<40mV _{PP}	<50mV _{PP}	<50mV _{PP}
Noise:	<100mV _{PP}			
Output current limit:	33A	15,5A	8,5A	4,5A
Overvoltage protection (OVP):	6,2V	15V	28V	55V
Switching frequency, converter type:	100kHz forward converter			
Line regulation (100% I _{OUT}): Δ i _{OUT}	0,6%	0,17%	0,08%	0,08%
Load regulation static (10...90% I _{OUT}): Δ i _{OUT}	2,0%	0,2%	0,3%	0,2%
Powerfail-Signal (at full load) >6ms before V _{OUT} :	yes			
Temperature-coefficient/°C:	0,02%			
Remote SENSE max.:	0,5V			
Derating: above 55°C	6,0W/°C			

TPS168	V1	V1	V1	V1
Output voltage:	5V	12V	24V	48V
Adjustment range:	fixed			
Output current:	40A	20A	10A	5,0A
Ripple:	<20mV _{PP}	<20mV _{PP}	<25mV _{PP}	<25mV _{PP}
Output current limit:	45A	22A	11A	5,5A
Noise:	<200mV _{PP}			
Overvoltage protection (OVP):	6,5V	16V	30V	65V
Switching frequency, converter type:	80kHz push-pull converter			
Line regulation (100% I _{OUT}): Δ i _{OUT}	0,6%	0,03%	0,03%	0,03%
Load regulation static (10...90% I _{OUT}): Δ i _{OUT}	0,9%	0,5%	0,3%	0,3%
Powerfail-Signal (at full load) >6ms before V _{OUT} :	yes			
Temperature-coefficient/°C:	0,02%			
Remote SENSE max.:	0,5V			
Derating: above 55°C	2,5W/°C			

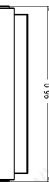

DC-DC

TPS Series: DC/DC Converter 19"-rack applications

Mechanical Details (Chassis mounts available)

TPS 133

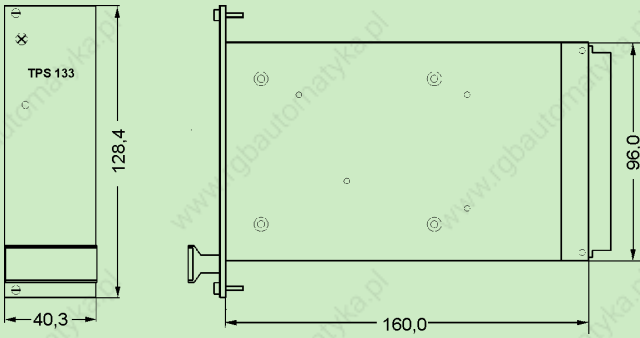

TPS 233

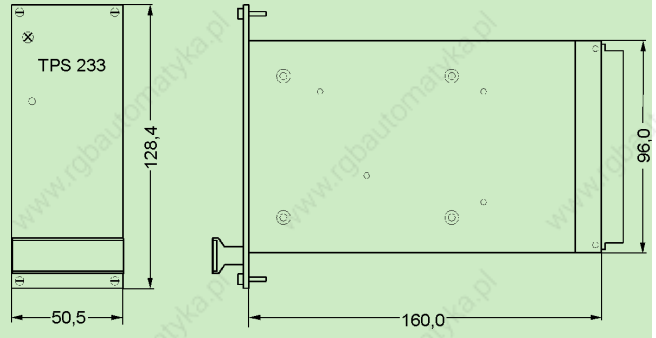

TPS 264

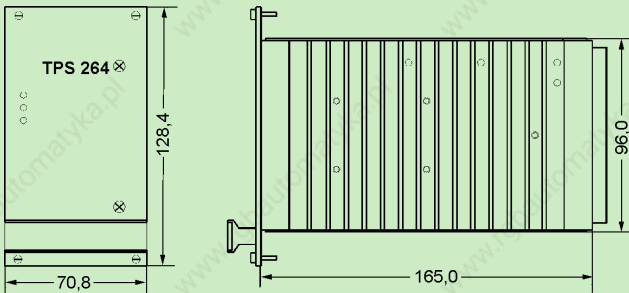

TPS 168

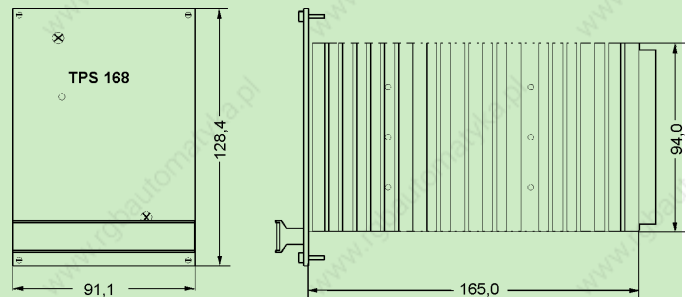

Pin allocation H15-connector

PIN	Function <i>TPS133</i>	Function <i>TPS264</i>	Function <i>TPS233</i>	Function <i>TPS168 5/12V</i>	Function <i>TPS168 24/48V</i>
4	+In	+In	+In	+In	+In
6	-In	-In	-In	-In	-In
8	Powerfail C	Powerfail	Powerfail C	+In	+In
10	Powerfail E	Powerfail	Powerfail E	-In	-In
12	NC	+Out 3	NC	+Out	PWR OK
14	Share	-Out 3	Share	+Out	PWR OK
16	NC	+Out 2	NC	+Out	PWR OK
18	NC	RTN	NC	Share	Share
20	+Out	+Out 1	+Out	+SENSE	+Out
22	+Out	+Out 1	+Out	-SENSE	+Out
24	+SENSE	+SENSE Out 1	+SENSE	-Out	+SENSE
26	-SENSE	+SENSE Out 1	-SENSE	-Out	-SENSE
28	-Out	RTN 1+2	-Out	-Out	-Out
30	-Out	RTN Out 1+2	-Out	-Out	-Out
32	GND	GND	GND	GND	GND

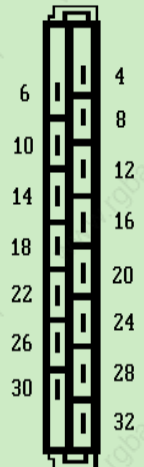

DC-DC

GK Series: MONOVOLT

Primary switched DC/DC-Converter for use in 19" applications to DIN41494, single output, 30 to 120 Watts output power.

Features

- Convection cooled
- Safety according EN60950
- CE marked for compliance to EMC and Low Voltage Directives
- No minimum load required
- Remote sense
- External on/off
- Overvoltage (OVP) and short circuit protected



GK-Series MONOVOLT Power Supplies

Ordering information

Description: MONOVOLT GK Series; 30W output power

Type	Output	Order-code
GK Series; 30W Output power		
GK 30-2 12VDC 3U x 8HP	5V/6A	116-010166A
GK 30-2 24VDC 3U x 8HP	5V/6A	116-010167J
GK 30-2 48VDC 3U x 8HP	5V/6A	116-010168F

GK Series; 60W Output power		
GK 60-2 24VDC 3U x 8HP	5V/12A	116-010034B
GK 60-2 24VDC 3U x 8HP	12V/5A	116-010035K
GK 60-2 24VDC 3U x 8HP	15V/4A	116-010036G
GK 60-2 24VDC 3U x 8HP	24V/2,5A	116-010037D

GK 60-2 48VDC 3U x 8HP	5V/12A	116-010038A
GK 60-2 48VDC 3U x 8HP	12V/5A	116-010039J
GK 60-2 48VDC 3U x 8HP	15V/4A	116-010040K
GK 60-2 48VDC 3U x 8HP	24V/2,5A	116-010041G

GK Series; 120W Output power		
GK 120 24VDC 3U x 14HP	5V/20A	116-010132C
GK 120 24VDC 3U x 14HP	12V/10A	116-010133L
GK 120 24VDC 3U x 14HP	24V/5A	116-010135E
GK 120 48VDC 3U x 14HP	5V/20A	116-010136B
GK 120 48VDC 3U x 14HP	12V/10A	116-010137K
GK 120 48VDC 3U x 14HP	24V/5A	116-010139D

Accessories:

Reduced height front panel: GK30	148-10012F
Reduced height front panel: GK60	148-10021E
Reduced height front panel: GK120	148-10019G
Mating connector coded H15 to DIN 41612	17-10115K
Coding keys (pkt 10)	17-10064F

Technical Data MONOVOLT GK Series

Input data

Input voltage: 12VDC (9..18V), 24VDC (18..36V), 48VDC (36..72V)

Inrush - current limit: line impedance dependent

Input overvoltage protection: by thyristor crowbar

Hold up time (Nominal V_{IN} ; 100% I_{OUT}): >3ms

Efficiency: typ. >70%

Safety (Compliant with Low Voltage Directive 73/23/EEC)

Isolation: input-output 0,5kVDC

Isolation: input-chassis 0,5kVDC

Isolation: output-chassis 0,5kVDC

EMC (Compliant with EMC Directive 89/336/EEC)

Emmissions: EN 55022

Immunity: EN 50082-2

Electro Static Discharge: EN 61000-4-2

Electrical fast transients/Burst: EN 61000-4-4

RF Conducted disturbance: EN 50141

RF Field susceptibility: EN 50140

Environmental

Operating temperature: 0°C to +70°C

Storage temperature: -25°C to +85°C

Relative humidity: Non-condensing 5% - 95%

Physical

Case material/finish: Clear anodised, ventilated aluminium cassette with cooling cutouts and front or rear heat sinks as applicable.

DIN 41494 part 5 compatible

GK Series: MONOVOLT

Output specifications

GK30	V1
Output voltage:	5V
Adjustment range:	4,8-5,5V
Output current:	0-6A
Ripple:	<40mV _{PP}
Line regulation (100% I _{OUT}): Δ iV _{OUT}	<0,2%
Load regulation static (10...90% I _{OUT}): Δ iV _{OUT}	<0,2%
Transient response (10...90% I _{OUT}):	1ms
Switching frequency, converter type:	85kHz forward converter
Output current limit:	>6,5A
Short circuit protection:	continuous, automatic restart
Overvoltage protection (OVP):	6-6,7V
Temperature coefficient/°C:	0,02%
Remote SENSE max. _{NOTE} :	0,5V
Derating above 55°C:	1W/°C above 55°C

GK60	V1	V1	V1	V1
Output voltage:	5V	12V	15V	24V
Adjustment range:	4,5-5,5V	11-13V	13,5-16,5V	22-26V
Output current:	0-12A	0-5A	0-4A	0-2,5A
Ripple:	<40mV _{PP}			
Line regulation (100% I _{OUT}): Δ iV _{OUT}	<0,3%	<0,2%	<0,2%	<0,2%
Load regulation static (10...90% I _{OUT}): Δ iV _{OUT}	<0,2%			
Transient response (10...90% I _{OUT}):	0,8ms	0,5ms	0,5ms	0,5ms
Switching frequency, converter type:	75kHz push-pull converter			
Output current limit:	>12,5A	>5,3A	>4,3A	>2,7A
Short circuit protection:	continuous, automatic restart			
Overvoltage protection (OVP):	5,5-6,0V	13,2-15,0V	16,5-18,0V	26,4-30,0V
Temperature coefficient/°C:	0,02%			
Remote SENSE max. _{NOTE} :	0,5V			
Derating above 55°C:	2W/°C above 55°C			

GK120	V1	V1	V1	V1
Output voltage:	5V	12V	15V	24V
Adjustment range:	4,5-5,5V	10,8-13,2V	13,5-16,5V	21,6-26,4V
Output current:	0-20A	0-10A	0-8A	0-5A
Ripple:	<40mV _{PP}			
Line regulation (100% I _{OUT}): Δ iV _{OUT}	<0,2%			
Load regulation static (10...90% I _{OUT}): Δ iV _{OUT}	<0,2%			
Transient response (10...90% I _{OUT}):	0,5ms			
Switching frequency, converter type:	85kHz push-pull converter			
Output current limit:	>22A	>11A	>8,8A	>5,5A
Short circuit protection:	continuous, automatic restart			
Overvoltage protection (OVP):	5,0-7,0V	12,0-16,5V	15,0-21,0V	27,0-29,0V
Temperature coefficient/°C:	0,02%			
Remote SENSE max. _{NOTE} :	0,5V			
Derating above 55°C:	4W/°C above 55°C			

DC-DC

GK Series: MONOVOLT

Mechanical Details

GK30, GK60

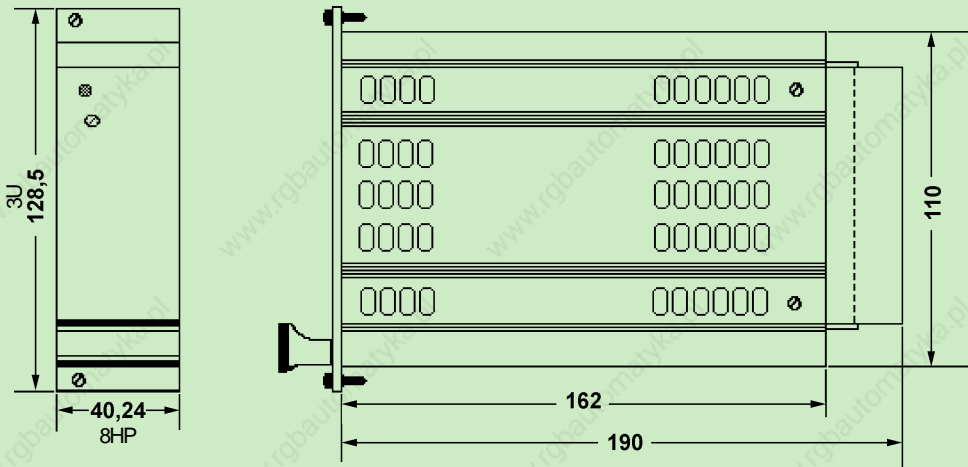

Weight: GK30, GK60 850g

GK120

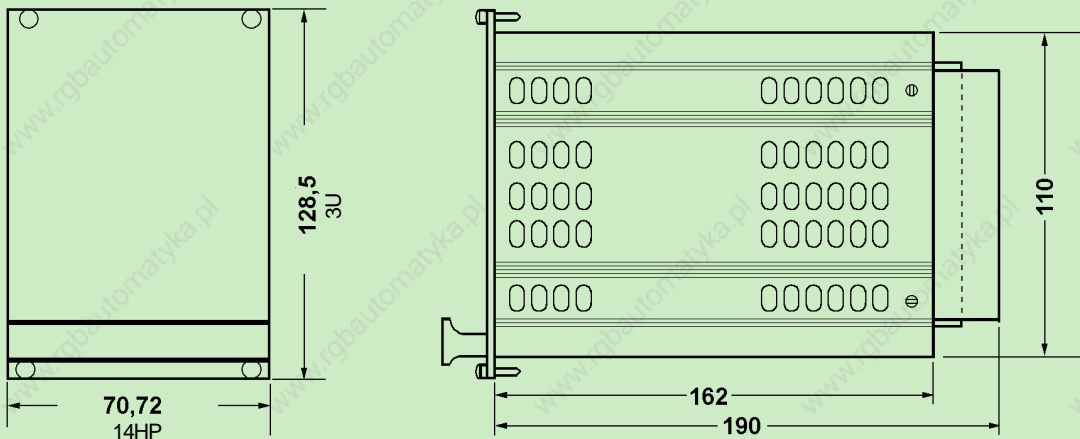

Weight: GK120 1350g

Pin allocation - H15 connector

PIN	Function	GK30	GK60	GK120
4	+Vout	+Vout	+Vout	+Vout
6	+Vout	+Vout	+Vout	+Vout
8	-Vout	-Vout	-Vout	-Vout
10	-Vout	-Vout	-Vout	-Vout
12	+SENSE	+SENSE	+SENSE	+SENSE
14	-SENSE	-SENSE	-SENSE	-SENSE
16	—	—	—	—
18	—	—	—	—
20	—	—	—	—
22	—	Ext on/off	Ext on/off	Ext on/off
24	-Vin	-Vin	-Vin	-Vin
26	-Vin	-Vin	-Vin	-Vin
28	+Vin	+Vin	+Vin	+Vin
30	+Vin	+Vin	+Vin	+Vin
32	GND	GND	GND	GND

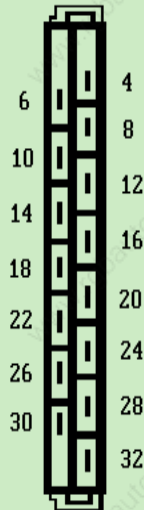

Note: Sense lines must be connected. For maximum compensation for supply lead voltage drop they should be connected as close to the load as possible

GK Series: BIVOLT

Primary switched DC/DC-Converter for use in 19" applications to DIN41494, single output, 30 and 60 Watts output power.

Features

- Convection cooled
- Safety according EN60950
- CE marked for compliance to EMC and Low Voltage Directives
- No minimum load required
- Overvoltage (OVP) and short circuit protected



GK-Series BIVOLT Power Supplies

Ordering information

Description: BIVOLT GK30, GK60;
3U x 8HP 30-60 Watt Output power

GK 30 Series; 30W Output power

Type	Outputs	Order-code
GK 30-2 12VDC	±12-15V/1A	116-010170D
GK 30-2 24VDC	±12-15V/1A	116-010171A
GK 30-2 48VDC	±12-15V/1A	116-010172J

BIVOLT, GK60; 3U x 8HP 60 Watt Output power

GK 60-2A 12VDC	±12-15V/2A	116-010152F
GK 60-2A 24VDC	±12-15V/2A	116-010153C
GK 60-2A 48VDC	±12-15V/2A	116-010154L

Accessories

Reduced height front panel: GK30	148-010013C
Reduced height front panel: GK60	148-010011J
Mating connector coded H15 to DIN 41612	017-010115K
Coding keys (pkt 10)	017-010064F

Technical Data GK Series: BIVOLT

Input Specification

Input voltage:	12VDC (9...18V), 24VDC (18...36V), 48VDC (36...72V)
Inrush - current limit:	line impedance dependent
Input overvoltage protection:	by Thyristor-Crowbar
Hold up time (Nominal V_{in} ; 100% I_{out}):	>3ms
Efficiency:	typ. >60-80%

Safety (Compliant with Low Voltage Directive 73/23/EEC)

Isolation: input-output	0,5kVDC
Isolation: input-chassis	0,5kVDC
Isolation: output-chassis	0,5kVDC

EMC (Compliant with EMC Directive 89/336/EEC)

Emmissions:	EN 55022
Immunity:	EN 50082-2
Electro Static Discharge:	EN 61000-4-2
Electrical fast transients/Burst:	EN 61000-4-4
RF Conducted disturbance:	EN 50141
RF Field susceptibility:	EN 50140

Environmental

Operating temperature:	0°C to +70°C
Storage temperature:	-25°C to +85°C
Relative humidity:	Non-condensing 5% - 95%

Physical

Case material/finish: Clear anodised, ventilated aluminium cassette with cooling cutouts and front or rear heat sinks as applicable.
 DIN 41494 part 5 compatible

GK Series: BIVOLT

Output specifications

GK30	V1, V2
Output voltage: adjustable	±12V - 15V
Output current:	±0-1A
Ripple:	<3mV _{pp}
Line regulation (100% I _{OUT}): Δ iV _{OUT}	<0,02%
Load regulation static (10...90% I _{OUT}): Δ iV _{OUT}	<0,2%
Transient response (10...90% I _{OUT}):	10ms
Switching frequency, converter type:	95kHz forward converter
Output current limit:	>1,1A
Short circuit protection:	continuous, automatic restart
Overvoltage protection (OVP):	-
Temperature-Coefficient/°C:	0,05%
Derating:	1W/°C above 55°C

GK60	A:V1,V2
Output voltage: adjustable	±12-15V
Output current:	±0-2A
Ripple:	<20mV _{pp}
Line regulation (100% I _{OUT}): Δ iV _{OUT}	<0,2%
Load regulation static (10...90% I _{OUT}): Δ iV _{OUT}	<0,5%
Transient response (10...90% I _{OUT}):	1ms
Switching frequency, converter type:	85-95kHz forward converter
Output current limit:	>2,2A
Short circuit protection:	continuous, automatic restart
Overvoltage protection (OVP):	on 5V-output only; other outputs optional
Temperature-Coefficient/°C:	0,05%
Derating:	2W/°C above 55°C

Mechanical Details

GK30, GK60

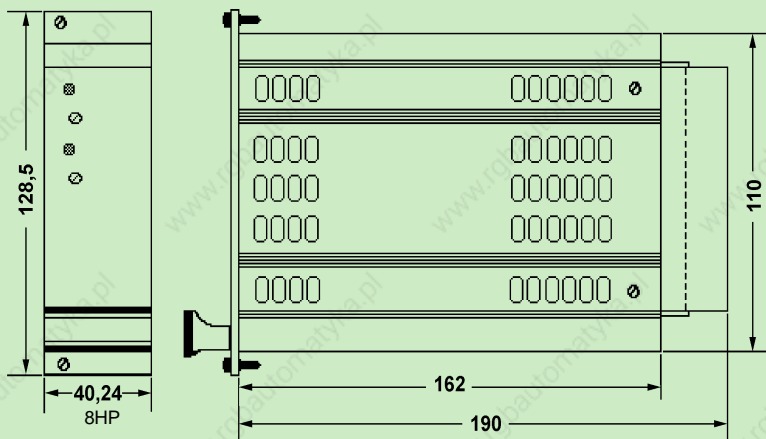

Pin Allocation H15-Connector

PIN	Function GK30	Function GK60
4	—	—
6	—	—
8	—	—
10	—	—
12	—	—
14	—	—
16	—	—
18	+12-15V	+12-15V
20	0V	0V
22	-12-15V	-12-15V
24	-Vin ^{Note}	-Vin
26	-Vin	-Vin
28	+Vin	+Vin
30	+Vin	+Vin
32	E	E

Note: Only on 12VDC input version

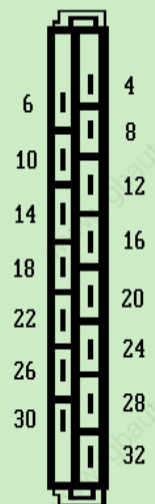

GK Series: Trivolt

Primary switched mode DC/DC converter for use in 19" applications to DIN41494, triple outputs 60 and 120 Watts

Features

- 3U/6U option on 120 Watt
- CE marked for compliance to EMC and Low Voltage Directives
- SENSE operation (5V output)
- Overvoltage (OVP) protection (5V output)
- Short circuit protected
- No minimum load required
- Coded H15 connector
- Standardized pinning
- Thermally optimised mechanical design
- Convection cooled



GK Series DC-DC Trivolt Plug-in power supplies

Ordering information

Description: Trivolt GK60: 3U x 8HP
60 Watt output

Model	Output	Order code
GK60-2A 12V	V1:5V/6A, V2/3: ±12-15V/1A	116-010097B
GK60-2A 24V	V1:5V/6A, V2/3: ±12-15V/1A	116-010098K
GK60-2A 48V	V1:5V/6A, V2/3: ±12-15V/1A	116-010099G

Accessories:

Reduced height front panel: GK60	148-010010A
Mating connector coded H15 to DIN 41612	017-010115K
Coding keys (pkt 10)	017-010064F

Description: Trivolt GK120: 3U x 14HP, 6U x 8HP
120 Watt output

Model	Output	Order code
GK120-2 3U 24V	5V/12A,+12-15V/2A	116-010175L
GK120-2 3U 48V	5V/12A,+12-15V/2A	116-010176H
GK120-2 6U 24V	5V/12A,+12-15V/2A	116-010179K
GK120-2 6U 48V	5V/12A,+12-15V/2A	116-010180L

Accessories:

Reduced height front panel: GK120 (3U)	148-010020H
Mating connector coded H15 to DIN 41612	017-010115K
Coding keys (pkt 10)	017-010064F

Pin allocation - H15 connector

PIN	Function	Function
	GK60	GK120
4	+5V	+5V
6	+5V	+5V
8	-Vout	-Vout
10	-Vout	-Vout
12	+SENSE	+SENSE
14	-SENSE	-SENSE
16	---	---
18	+12-15V	+12-15V
20	0V	0V
22	-12-15V	-12-15V
24	-Vin Note	---
26	-Vin	-Vin
28	+Vin	+Vin
30	+Vin	+Vin
32	E	E

Note: Only on 12VDC input version

Technical Data GK Series: Trivolt

Input specification

Input voltage:	12VDC, 24VDC, 48VDC
Inrush surge current limitation:	line input impedance dependent
Input overvoltage protection:	by thyristor crowbar
Hold up time (Nominal V_{in} ; 100% I_{out}):	>3ms
Efficiency:	typ. >70-75%

Safety (Compliant with Low Voltage Directive 73/23/EEC)

Isolation: input-output	0,5kVDC
Isolation: input-chassis	0,5kVDC
Isolation: output-chassis	0,5kVDC

EMC (Compliant with EMC Directive 89/336/EEC)

Emmissions:	EN 55022
Immunity:	EN 50082-2
Electro Static Discharge:	EN 61000-4-2
Electrical fast transients/Burst:	EN 61000-4-4
RF Conducted disturbance:	EN 50141
RF Field susceptibility:	EN 50140

Environmental

Operating temperature:	0°C to +70°C
Storage temperature:	-25°C to +85°C
Relative humidity:	Non-condensing 5% - 95%

Physical

Case material/finish: Clear anodised, ventilated aluminium cassette with cooling cutouts and front or rear heat sinks as applicable.
DIN 41494 part 5 compatible



GK Series: Trivolt

Output specification

GK60	V1	V2/3
Output voltage:	5V	±12-15V
Output adjustment range:	4,5-5,5V	-
Output current:	0-6A	±0-1A
Ripple:	<40mV _{PP}	<3mV _{PP}
Line regulation (100% I _{OUT}): iV _{OUT}	<0,2%	<0,02%
Load regulation static (10...90% I _{OUT}): iV _{OUT}	<0,2%	<0,2%
Transient response (10...90% I _{OUT}):	1ms	10ms
Switching frequency, converter type:	85-95kHz forward converter	
Current limit:	>6,5A	>1,1A
Short circuit protection:	continuous, automatic restart	
Overvoltage protection (OVP):	6-6,7V	-
Powerfail Signal (at full load) >6ms before V _{OUT} :	<4,8V	-
Temperature coefficient/°C:	0,02%	
Voltage compensation with SENSE max. _{NOTE1} :	0,5V	-
Derating:	2W/°C above 55°C	

GK120	V1	V2,V3
Output voltage:	5V	±12-15V
Output adjustment range:	4,5-5,5V	-
Output current:	0-12A	0-2A
Ripple:	<40mV _{PP}	<20mV _{PP}
Line regulation (100% I _{OUT}): Δ iV _{OUT}	<0,2%	
Load regulation static (10...90% I _{OUT}): Δ iV _{OUT}	<0,2%	
Transient response (10...90% I _{OUT}):	<0,2ms	<0,5ms
Switching frequency, converter type:	75-95kHz push-pull forward converter	
Current limit:	>12,5A	>2,2A
Short circuit protection:	continuous, automatic restart	
Overvoltage protection (OVP):	5,5-6,0V	-
Powerfail Signal (at full load) >6ms before V _{OUT} :	<4,8V	-
Temperature coefficient/°C:	0,05%	
Voltage compensation with SENSE max. _{NOTE1} :	0,5V	-
Derating:	4W/°C above 55°C	

Mechanical details

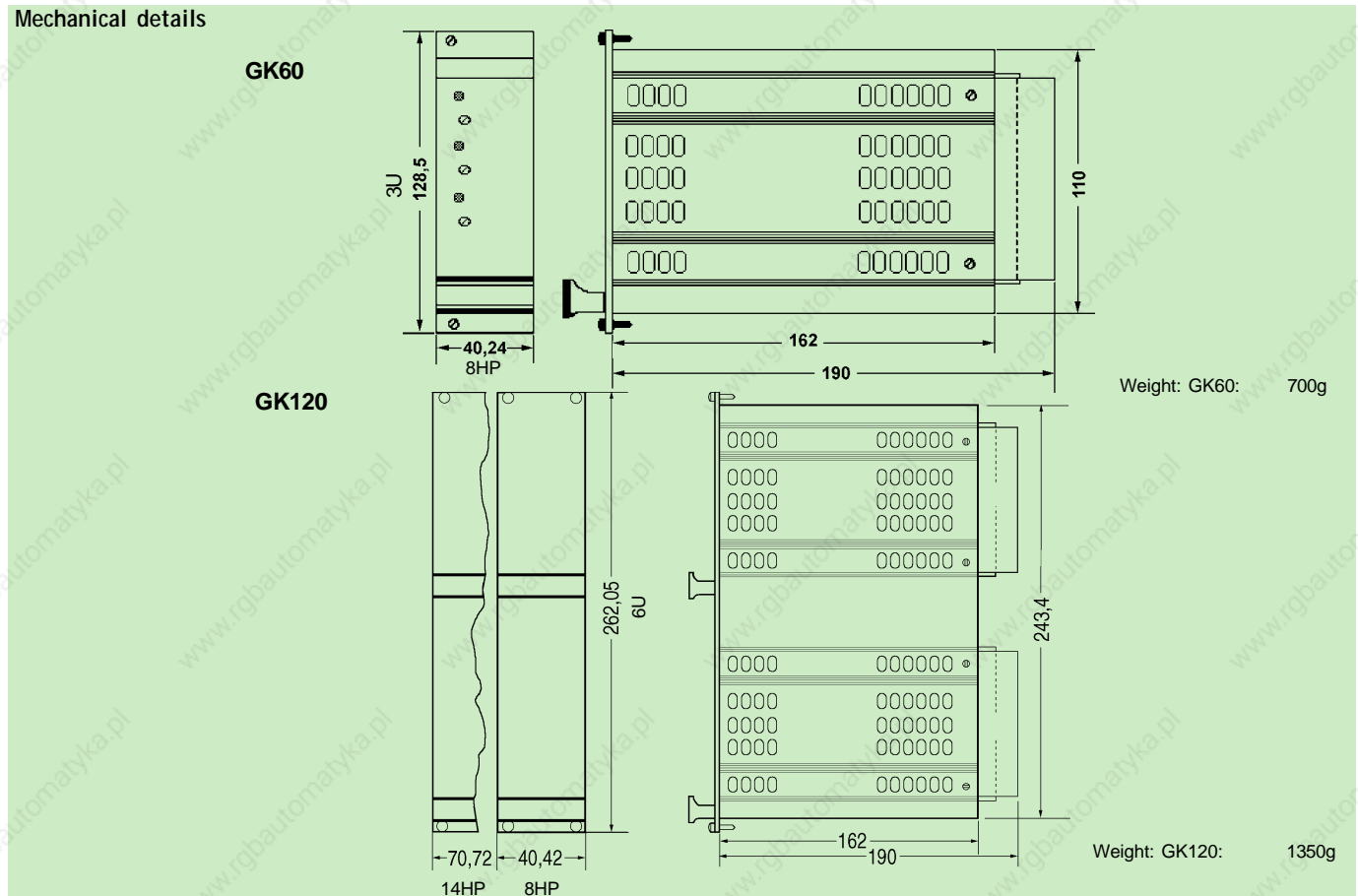

DC-DC

Custom Power Supplies



ac-dc
dc-dc
ac-dc
dc-dc
ac-dc
dc-dc
ac-dc
dc-dc
ac-dc
dc-dc
ac-dc
dc-dc

DC-DC AC-DC

Custom Power Supplies

VERO + Danica has established itself as a major supplier of custom Euromodular power supplies.

Customisation essentially falls into two areas;

Modified standard units

Fully customised units

Modified standard product can be a simple change to a front panel to a variation in the output configuration. Fully customised solutions start with the fundamental design and provide a cost-optimised product providing exactly the power and features required by the end-user.

Design solutions for active current share, N+1 redundancy including "hot-swap" and synchronisation of switching elements within the power supply and its partners are featured in design programs as a means of limiting the emissions spectrum. VERO + Danica sees benefits in increasing the switching frequency of its product range, improving power density.

Computer Aided Design and circuit simulation systems are linked directly to drilling and routing machines. This combination of technologies allows high quality prototype PCBs to be produced within a few hours, greatly reducing the time required to produce the "first off" unit.

VERO + Danica tests each custom design with a **thermal imaging** system. This allows engineers to determine the areas of the power supply that would benefit from additional or improved cooling and to amend the unit at prototype stage.

High voltage and earth continuity testing and burn-in facilities are custom systems, designed by VERO + Danica. Final test is centred around NH Research Powertest 8100i and 8105i auto-testers. All of these facilities are computer controlled, can include customer's own profiles, and are linked into the main product database.

Just-In-Time Manufacturing techniques are employed to improve delivery times and maintain even stricter control of manufacturing quality. Within VERO + Danica the adoption of J.I.T. ensures that the build-to-delivery time is kept to an absolute minimum, by eliminating manual production control procedures.

European Union EMC Directive #83/336/EEC places responsibility on OEMs to ensure that their apparatus or equipment complies with the requirements of European legislation.

As a responsible company VERO + Danica believes that it has an obligation as the manufacturer of product which, although a component part, contributes to the overall emissions of a system. To ensure that these emissions are minimised VERO + Danica will work with OEMs to provide the optimum solution. VERO + Danica has invested significant resource in ensuring that its products not only meet, but exceed, the requirements of the European laws, and compliance statements are available on request.

VERO + Danica has customers in all market sectors. Most significantly in the telecommunications and railway industries and this is illustrated in greater detail on the following pages.

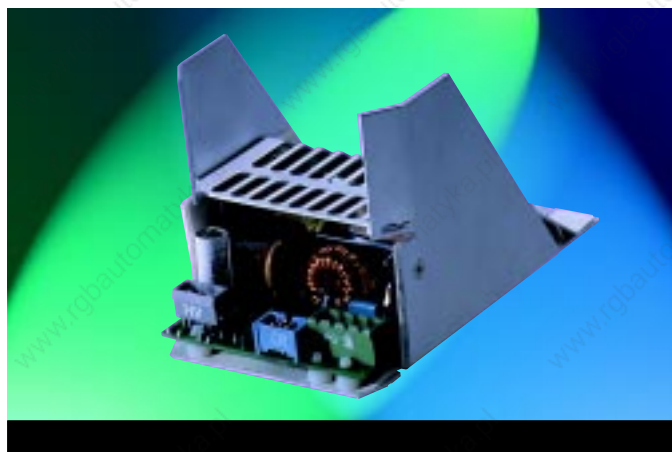

Power Supplies for Telecom - Applications

The strength of EA VERO + Danica is not limited to any particular type of unit.

Both AC and DC inputs with single and multiple outputs are part of the product range in production.

Many of the designs offer features not normally found in standard solutions. For AC inputs power factor correction is generally standardised to ensure compliance with pending harmonic correction legislation. DC input units are compliant with worldwide telecoms input specifications.

Many outputs are current sharing or N+1 configuration with converter synchronisation between units. Output alarms and voltage start-up sequencing are also available.

Integral cooling, which can also contribute to the overall thermal management of a system, can be incorporated.



The photograph (top right), depicts a 48VDC input, triple output power supply with mechanical latching to prevent accidental removal of the unit when in a "live" environment.

The second photograph shows a 700Watt, power factor corrected AC-DC unit with five outputs, any of which can be accessed from the front or rear of the unit as required.



The third photograph illustrates a 1000 Watt DC-DC converter with six outputs, power sharing and synchronised switching for cellular communications base stations.



MONOVOLT GC75-R

Primary switched mode 75W DC-DC power supply for redundant systems, optional 24 or 48VDC input.

Features

- Active load sharing for redundant systems
- Parallel operation
- Integrated decoupling diodes for hot swap
- Front heat sink for optimum thermal performance
- Thermal overvoltage protection
- Redundant feed possible
- Safety to EN60950, UL1950, CSA22.2/950
- Emissions to EN50082-2, EN50081-1

Type	Input	Output	Dimensions
EA-GC75-R	24VDC or 48VDC	5V/15A	3U x 8HP x 160mm



Power supplies for railway applications



Primary switched mode power supplies for railway applications.
Versions suitable for 19" applications or chassis mounting.

These power supplies are specially designed for use in rolling stock and railway applications. These units operate from either 24V or 110V DC input and have been extensively tested in accordance with the anticipated harsh environmental conditions possible in applications.

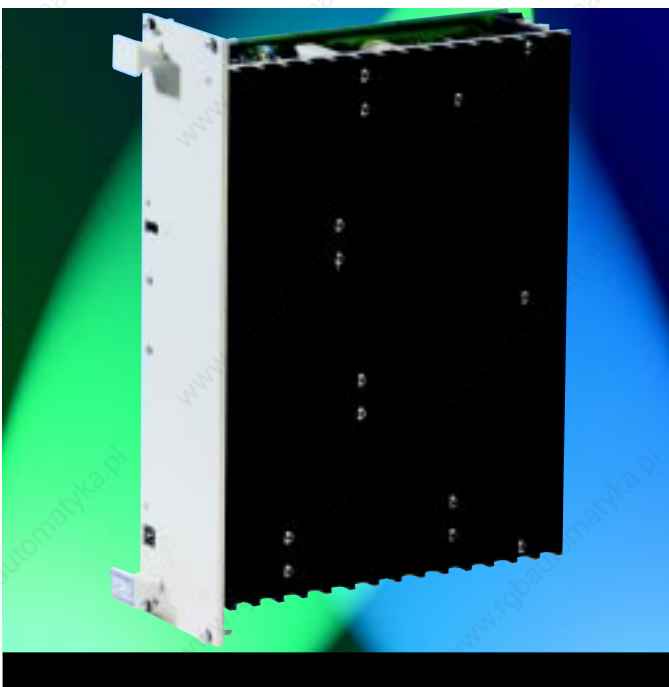

The power supplies are manufactured and tested to railway standard BN411002 (May 1996) and EN50155 (VDE 0115, part 200). To assure long term reliability, temperatures of individual components and mechanical hot spots have been tested, monitored and reduced. (Part stress analysis)

EMC

Electro magnetic compatibility (EMC) is an important aspect of designing a system. In order to get approval for the complete system, it is easier if all the component parts are individually approved. All power supplies are tested by independent, accredited laboratories. Diced testing during the development of the power supplies ensures that the production units meet the relevant specifications.



The power supplies for railway applications are developed and specified predominantly to EMI 50121-3-2 (VDE 0115, Part 121-3-2) with regard to EMC. These standards contain:

- Emission in accordance with: EN 55011
- Resistance in accordance with: EN 61000-4-2 (ESD)
- EN 61000-4-4 (Burst)
- EN 61000-4-5 (Surge)
- EMI50141 (RF admission)
- EMI 50140 (RF emission)

Railway application power supplies: Monovolt, Bivolt, Trivolt

Suitable for 19" applications for chassis mount, 1-3 output voltages and 60 - 500Watts output

Features

- #
- Input filter with suppressor diodes
- Reverse input voltage protection
- Sensor connections
- Wide operating temperature range, typically -40°C to +85°C
- Input undervoltage switch-off
- DC Good signal

All listed features are typical of the range and not specific to any particular unit. Please contact EA for detailed information



GB60 MONOVOLT/BIVOLT

Technical Data: Monovolt, Bivolt, Trivolt

Input specification

Input voltage:	24VDC or 110VDC
Efficiency:	typ. >75% - >80%

Safety

Safety:	in accordance with EN50155, or better
---------	---------------------------------------

EMC

Emissions:	in accordance with ENV 50121-3-2
------------	----------------------------------

Physical

Dimensions:	see ordering information
-------------	--------------------------

Environmental

Operating temperature: typically	-40°C to +85°C
Storage temperature: typically	-50°C to +100°C
Vibration, oscillation, environment:	certified to BN411002, EN 50155



GK80 TRIVOLT



GB500 MONOVOLT

Ordering information

Description: Railway application power supplies. For detailed specifications, prices and minimum order quantities contact Elektro-Automatik

Type	Input	Tolerance	Output	Mechanics
Monovolt GB60#	24VDC	14,4-51VDC	5V/12A	3U x 9HP x 160mm - plug-in
Monovolt GB60#	110VDC	77-138VDC	5V/12A	3U x 9HP x 160mm - plug-in
Monovolt GB100#	24VDC	14,4-51VDC	24V/4.2A	3U x 12HP x 160mm - plug-in
Monovolt GB100#	110VDC	40-154VDC	24V/4.2A	3U x 12HP x 160mm - plug-in
Monovolt GB150#	24VDC	16,8-45,2VDC	24V/6.3A	110mm x 172mm x 100mm - wall mounting
Monovolt GB150#	110VDC	50,4-138VDC	24V/6.3A	110mm x 172mm x 100mm - wall mounting
Monovolt GB500#	110VDC	77-143VDC	24V/21A	225mm x 200mm x 90mm - wall mounting
Bivolt GB60#	24VDC	14,4-51VDC	±15V/2A	3U x 9HP x 160mm - plug-in
Bivolt GB60#	110VDC	40-154VDC	±15V/2A	3U x 9HP x 160mm - plug-in
Trivolt GK80	24VDC	16-32VDC	5V/4A;±15V/2A	6U x 8HP x 160mm - plug-in
Trivolt GK80	110VDC	77-143VDC	5V/4A;±15V/2A	6U x 8HP x 160mm - plug-in
Trivolt GB135	110VDC	77-143VDC	5V/15A;±15V/2A	6U x 12HP x 160mm - plug-in

Development for optimum customer benefit

The development division has a very high priority inside this dynamic firm. As a result EA systems have always represented power technology at the cutting edge.

All EMC measurements (electromagnetic compatibility) are carried out in house. All products carry the **CE** mark.

Our experienced design and development team reacts quickly to assist customers in the application of our power conversion equipment.

Among the special developments, for example, are devices for power feed back into the mains network, switch mode laboratory power supplies from 320W up to 24kW, switching inverters up to 2500 VA (capable for parallel operation) and 19" power supply modules up to 3000 Watt for the telecommunications sector.

Indoor and Outdoor DC power systems for the telecom sector. The feature shared by all these developments is the optimum power utilisation due to high efficiency.



CAD Workstation



Final test before production start



Electromagnetic compatibility test (EMC)

The complete EA power supply programme...

EA's extensive range of standard power conversion products enables us to provide the optimum solution to a wide range of applications and environments. The diversity and quality of the portfolio being unrivalled nationally or internationally.

Dealing directly with the design source we are able to offer our customers in depth technical advise and modified standards where required. Complete power systems including control, monitoring, distribution and battery back up are a standard service.

Dedicated production teams and flexible operations enable EA where required to guarantee short production lead-times, even on custom low volume runs.



Battery Back-Up System for Telecommunications units

- Low Cost and Universal Power Supplies
- Standard Laboratory Power Supplies
- Special - Laboratory Power Supplies
- High Performance Power Supplies
- IEEE-488 and CAN-BUS Interfaces
- Uninterruptible Power Supply units
- Rackmount power supplies, Open Frame, 19" and modules
- DC/DC converter
- Battery chargers
- DC/AC inverter
- AC-sources and high voltage power supplies
- DC-Back-Up Systems for telecommunications units
- Electronic loads with mains feedback



Primary switching laboratory power supply



Low Cost laboratory power supply series EA-PS 2000

...for the following areas of application

- Industry
- Laboratories
- Research institutes
- Regenerative Energy
- Telecommunications
- Laser technology
- Public services
- Universities
- Automotive industry
- Medical technology
- Workshops
- Office applications



Primary switched laboratory power supply series 9000 up to 24kW



Laboratory power supplies series 7000A i.e. for school applications



DC - AC Sine-wave inverter 2500VA



THE COMPLETE POWER SUPPLY PROGRAM

LABORATORY AND FIXED VOLTAGE POWER SUPPLIES

- LINEAR REGULATED, 80W TO 32kW
- PRIMARY SWITCHED, 320W TO 24kW
- OUTPUT UP TO 12kV
- OUTPUT CURRENT UP TO 2000A
- BENCH, EUROMODULE- OR 19"-VERSIONS

CHASSIS MOUNT POWER SUPPLIES

- LINEAR REGULATED, 5W TO 540W
- PRIMARY SWITCHED, 12W TO 12000W
- OUTPUT: 5V, 12V, 15V, 24V, 48V and 60V
- OUTPUT CURRENT UP TO 250A
- 19"-MODULES, CHASSIS or DIN RAIL MOUNTING

VARIABLE AC POWER SOURCES

- LINEAR BROADBAND POWER STAGE
- HIGH AND LOW VOLTAGES
- 500VA TO 2000VA
- OUTPUT: 6V TO 10000V
- OUTPUT CURRENT 50mA TO 320A

POWER SUPPLIES FOR TELECOMMUNICATION EQUIPMENT

- FROM 150W TO 8kW
- BACK-UP SYSTEMS FROM 5kW TO 24kW
- AC - DC INVERTER, 3/6U from 60W to 2750W
- DC - DC CONVERTER, 3/6U from 50W to 500W
- OUTPUT CURRENT UP TO 600A

DC-AC SQUARE AND SINE WAVE INVERTER

- 150VA to 5kVA, 19"- RACK, BENCH
and CHASSIS MOUNT VERSIONS
- DC INPUT 11...60V
- SUPERVISION FUNCTIONS
- PARALLEL OPERATION for
REDUNDANT SYSTEMS

ELECTRONIC LOAD WITH MAINS FEED BACK

- 2000W
- DC INPUT VOLTAGE 3...60V
- APPLICATIONS:
BATTERY CAPACITY TESTS
BURN - IN TEST
SOLAR APPLICATIONS
- CONSTANT CURRENT
CONSTANT RESISTANCE
CONSTANT POWER
- MAINS FEED BACK

IEEE-488.2 RS232 INTERFACES RS 232 - CAN - BUS INTERFACES

- DIGITAL CONTROL UNIT
- CONTROL OF POWER SUPPLIES

Additional products

**Complete Back-up Systems
Indoor & outdoor
For telecom applications
0,1kW to 24kW with internal
or external batteries**



**Back-up Systems up to
24kW, Indoor and outdoor**

19" AC-DC systems 6U, up to 9kW



**6U module
48V/1800W**



Ask for our "TELECOM" catalogue!

THE COMPLETE POWER SUPPLY PROGRAM

**Laboratory Power Supply 80W to 34kW
Fixed Voltage Power Supplies 20-34kW
High Voltage Power Supplies
AC-Voltage sources to 2kW
DC-AC Inverter 100W to 4kVA
Electronic Loads**

**Laboratory Power Supply
Series 2000, 80 + 160W**



**Laboratory Power Supply
Series 9000, 320 to 1300W**



**Laboratory Power Supply
Series 9000, 2kW to 9kW**



Ask for our catalogue "The Complete Power Supply Program"!

Switched mode power supplies

**AC/DC power supplies 25 to 500W
1 - 4 outputs with PFC
Wide input voltage range 88...264VAC**

**DC/DC converters 25 to 150 W
Input voltage range 19-370VDC**

Chassis mount & open frame versions



**240W
with PFC**



**500W
with PFC**

Ask for our "Switching Power Supplies" catalogue!

EA-ELEKTRO-AUTOMATIK

**Helmholtzstr. 31-37, 41747 VIERSEN,
Germany**

Tel: 02162-3785-0 Fax: 02162-16230

E-mail: info@elektroautomatik.de www.elektroautomatik.de

EA-Elektro-Automatik Ltd.

**Unit 10, Centre One
Lysander Way
Old Sarum, Salisbury
Wiltshire, SP4 6BU, England
Tel: +44 1722 41 47 80
Fax: +44 1722 33 54 58**

E-mail: j.scott@elektroautomatik.de

EA-Elektro-Automatik

**Scandinavian Office
Møllebakken 13
DK-5672 Broby
Denmark
Tel: +45 7026 1544
Fax: +45 7026 1545**

E-mail: jens.vett@elektroautomatik.de