

Function and technology used in handwheels

The change from a handwheel directly coupled to the spindle or axes to CNC-controlled axes has meant dramatic new developments for the handwheels. The rotation of the handwheel generates square-wave outputs. The CNC axis controller evaluates the pulses and so signals the axis to move. With over 20 years of handwheel experience, EUCHNER provides a wide selection of handwheels built with the finest quality and highest possible reliability.

Daily use of handwheels places high demands on the mechanical functioning. With twin bearings and a wear-free detent mechanism, the EUCHNER handwheels are the optimum choice for trouble-free operation. The detent moment maintains position even in the event of machine vibration. The detent moment and 100 or 25 pulses per revolution allow a desired value to be set quickly, reliably and accurately. In addition to the manual positioning of axes with CNC-controlled machines, EUCHNER also offers handwheels used for medical and telecommunication applications. EUCHNER also offers handwheels for these applications.



Magnetic detent mechanism

Handwheels with magnetic detent are characterized by their absolutely wear-free and noiseless detent mechanism.

With 100 detent positions (100 or 25 pulses)

The detent mechanism is generated by a magnetic field. A combination of 100 magnetic north/south positions is generated by the opposing magnetic fields with one revolution of the handwheel. Thanks to an air gap, the detent mechanism has no wear and is absolutely maintenance-free. With two ball bearings, the bearing assembly of the handwheel can withstand high axial and radial forces. Different circuit outputs are available for all current control systems.

There are three different designs available:

- ▶ Design HKB
 - Ideal for flat machine panels and small, light hand-held pendant stations.

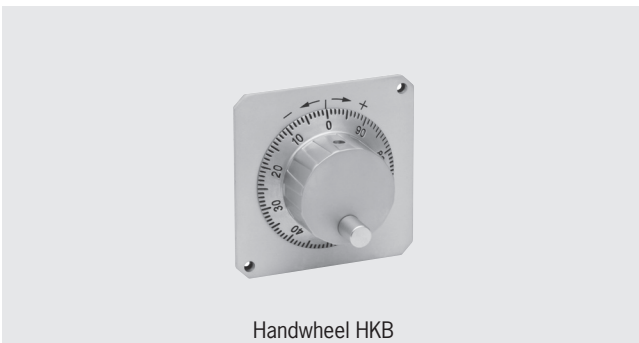

- ▶ Design HKC
 - Suitable for installation in operator panels
 - Its design makes it particularly suitable for flat operator panels



- ▶ Design HKD
 - Suitable for installation in operator panels and EUCHNER hand-held pendant stations from series HBL
 - Suitable for installation in universal turning and milling machines for axis movement, for example



Mechanical detent mechanism

Handwheels with mechanical detent are characterized by their light weight and shallow mounting depth.

With 100 detent positions (100 or 25 pulses)

A toothed rotor working in conjunction with a roller creates the detent mechanism. The roller is pushed between the teeth of the rotor by a spring and dial. The detent moment is produced by the movement of the roller over the teeth.

There are two different designs available:

- ▶ Design HWA
 - Suitable for installation in operator panels.
 - Suitable for installation in EUCHNER hand-held pendant stations
 - With center point fixing



- ▶ Design HWB
 - Suitable for installation in operator panels
 - With 3-point fixing



Handwheel HKB



- ▶ 100 detent positions per revolution
- ▶ Wear-free magnetic detent mechanism
- ▶ 100 or 25 pulses per revolution
- ▶ Key function in axial direction optional
- ▶ Ideal for flat operator panels and small, light hand-held pendant stations like HBA/HBM



Dimension drawing

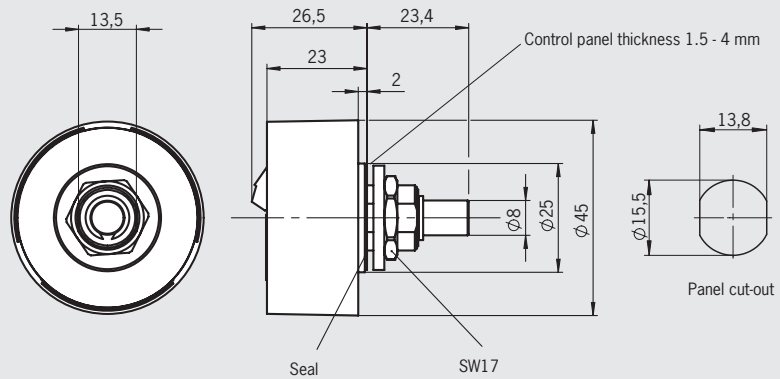

Notes

- ▶ Output A05 suitable for Siemens control systems with RS422 input
- ▶ Output G05 suitable for Fanuc control systems
- ▶ Dial: see accessories page 72
- ▶ Front panel: see accessories page 72

Version with key function

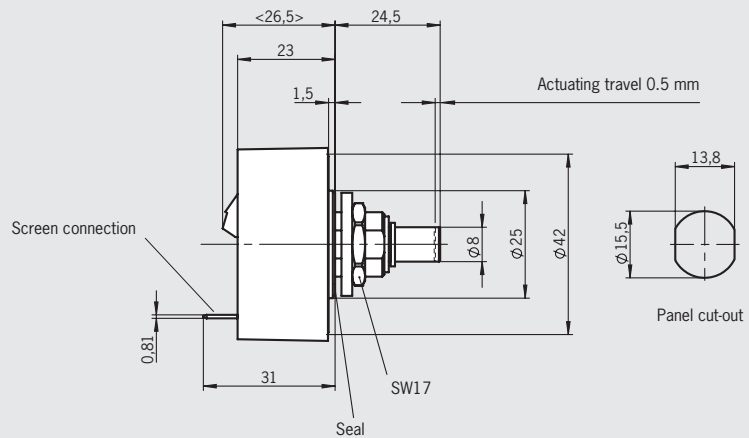

Ordering table

Series	Number of pulses per revolution	Connection	Detent positions	Outputs	Order No./item
HKB	25	S Screw terminal	100	G12 Push-pull 5 V $U_B = 10 \dots 30 \text{ V DC}$	105137 HKB025S7G12
	100	S Screw terminal	100	A05 RS422A $U_B = 5 \text{ V DC}$	105134 HKB100S7A05
				A12 RS422A $U_B = 10 \dots 30 \text{ V DC}$	105135 HKB100S7A12
				G05 5 V push-pull $U_B = 5 \text{ V DC}$	105136 HKB100S7G05
				G24 Push-pull 10...30 V $U_B = 10 \dots 30 \text{ V DC}$	105138 HKB100S7G24
HKB with key function	100	S Screw terminal	100	A05 RS422A $U_B = 5 \text{ V DC}$	109429 HKB100S7A05K

Technical data

Parameter	Value		Unit
Pulses per revolution	2 x 25 or 2 x 100		
Detent positions	100		
Housing material	Aluminum		
Weight	0.095		kg
Detent mechanism	Magnetic		
Shaft loading, axial, max.	25		N
Shaft loading, radial, max.	40		N
Mechanical life, min.	5 x 10 ⁶		Rev.
Operating temperature	0 ... +50		°C
Storage temperature	-20 ... +50		°C
Atmospheric humidity, max.	80% (condensation not permissible)		
Front degree of protection	acc. to EN 60529/IEC 529	IP 65	
	acc. to NEMA 250	250-12	
Resistance to vibration			
Vibrations (3 axes)	DIN/IEC 68-2-6		
Shock (3 axes)	DIN/IEC 68-2-7		
EMC protection requirements in accordance with CE	EN 61000-6-2, EN 61000-6-4		
Key function			
Mechanical life, min.	1 x 10 ⁶ actuations		
Actuating travel	0.3 ... 0.7 mm		
Specification output OUT			
	Output stage		
	A05/G05	A12/G12/G24	
Operating voltage U _B	DC 5 V ± 5 %		DC 10 ... 30 V
Output voltage	HIGH (1), min.	4.0 V/0 mA	-
		3.4 V/5 mA	-
		3.0 V/20 mA	U _B - 3 V/20 mA
		1.3 V/15 mA	3 V/20 mA
LOW (0), max.			
Output circuit RS422A			
Output stage	A05		A12
Output signals	A, /A, B, /B		
Operating voltage U _B	5 ± 5 %		10 ... 30
Operating current, no load, max.	80		
Output circuit	According to RS422A, use RS422 differential receiver module		
Output signals cw (clockwise rotation)			
Terminal assignment	Screw terminal, 7-pin, conductor cross-section 0.08 ² ... 1.5 ² (AWG 22 ... 16) Tightening torque, max. 0.5 Nm		
	<div style="display: flex; justify-content: space-around;"> <div style="text-align: center;"> <p>without key function</p> </div> <div style="text-align: center;"> <p>with key function</p> </div> </div>		
Output circuit, push-pull			
Output stage	G05	G12	G24
Output signals	A, B		
Operating voltage U _B	5 ± 5 %		10 ... 30
Operating current, no load, max.	80		
Output voltage	HIGH (1), min.	4.0 V / 0 mA	4.9 V / 0 mA
		3.4 V / 5 mA	3.9 V / 5 mA
		3.0 V / 20 mA	3.6 V / 20 mA
		1.3 V / 15 mA	3 V / 20 mA
LOW (0), max.			
Output current per output, max.	20		
Output signals cw (clockwise rotation)			
Terminal assignment	Screw terminal, 7-pin, conductor cross-section 0.08 ² ... 1.5 ² (AWG 22 ... 16) Tightening torque, max. 0.5 Nm		
	<div style="display: flex; justify-content: space-around;"> <div style="text-align: center;"> <p>without key function</p> </div> <div style="text-align: center;"> <p>with key function</p> </div> </div>		

Handwheel HKC



- ▶ 100 detent positions per revolution
- ▶ Wear-free magnetic detent mechanism
- ▶ 100 or 25 pulses per revolution
- ▶ Flat design



Dimension drawing

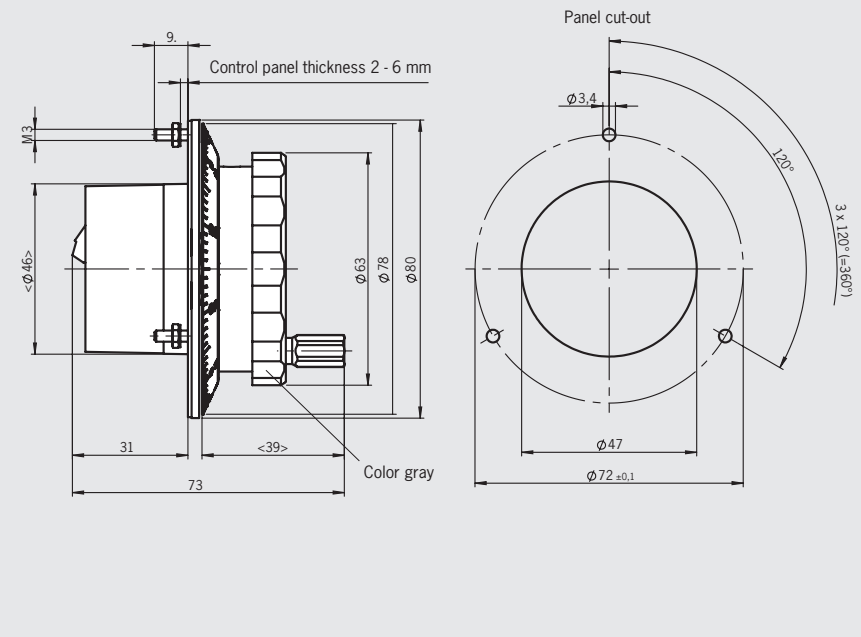

Notes

- ▶ Output A05 suitable for Siemens control systems with RS422 input
- ▶ Output G05 suitable for Fanuc control systems

Ordering table

Series	Number of pulses per revolution	Connection	Detent positions	Outputs	Order No./item
HKC	25	S Screw terminal	100	G12 Push-pull 5 V $U_B = 10 \dots 30 \text{ V DC}$	072940 HKC025S100G12
	100	S Screw terminal	100	A05 RS422A $U_B = 5 \text{ V DC}$	087733 HKC100S100A05
				G05 Push-pull 5 V $U_B = 5 \text{ V DC}$	082573 HKC100S100G05
				G24 Push-pull 10...30 V $U_B = 10 \dots 30 \text{ V DC}$	087739 HKC100S100G24

Technical data

Parameter	Value		Unit
Pulses per revolution	2 x 25 or 2 x 100		
Detent positions	100		
Housing material	Plastic/metal		
Weight	0.25		kg
Detent mechanism	Magnetic		
Shaft loading, axial, max.	25		N
Shaft loading, radial, max.	40		N
Mechanical life, min.	5 x 10 ⁶		Rev.
Operating temperature	0 ... +50		°C
Storage temperature	-20 ... +50		°C
Atmospheric humidity, max.	80% (condensation not permissible)		
Front degree of protection	acc. to EN 60529/IEC 529	IP 65	
	acc. to NEMA 250	250-12	
Resistance to vibration			
Vibrations (3 axes)	DIN/IEC 68-2-6		
Shock (3 axes)	DIN/IEC 68-2-27		
EMC protection requirements in accordance with CE	EN 61000-6-2, EN 61000-6-4		
Output circuit RS422A			
Output stage	A05		
Output signals	A, /A, B, /B		
Operating voltage U _B	5 ± 5 %		V DC
Operating current, no load, max.	80		mA
Output circuit	According to RS422A, use RS422 differential receiver module		
Output signals cw (clockwise rotation)			
Terminal assignment	Screw terminal S 		
Output circuit, push-pull			
Output stage	G05	G12	G24
Output signals	A, B		
Operating voltage U _B	5 ± 5 %	10 ... 30	
Operating current, no load, max.	80		
Output voltage	HIGH (1), min.	4.0 V / 0 mA	4.9 V / 0 mA
		3.4 V / 5 mA	3.9 V / 5 mA
		3.0 V / 20 mA	3.6 V / 20 mA
	LOW (0), max.	1.3 V / 15 mA	1.3 V / 15 mA
Output current per output, max.	20		
Output signals cw (clockwise rotation)			
Terminal assignment	Screw terminal S 		

Handwheel HKD



- ▶ 100 detent positions per revolution
- ▶ Wear-free magnetic detent mechanism
- ▶ 100 or 25 pulses per revolution
- ▶ Installation in operator panels and EUCHNER hand-held pendant stations HBL



Notes

- ▶ Output A05 suitable for Siemens control systems with RS422 input
- ▶ Output G05 suitable for Fanuc control systems
- ▶ Dial: see accessories page 72
- ▶ Front panel: see accessories page 72

Mounting depth I

Connection	I [mm]
Screw terminal S	55
Ribbon cable, 6-pin V	53

Dimension drawing

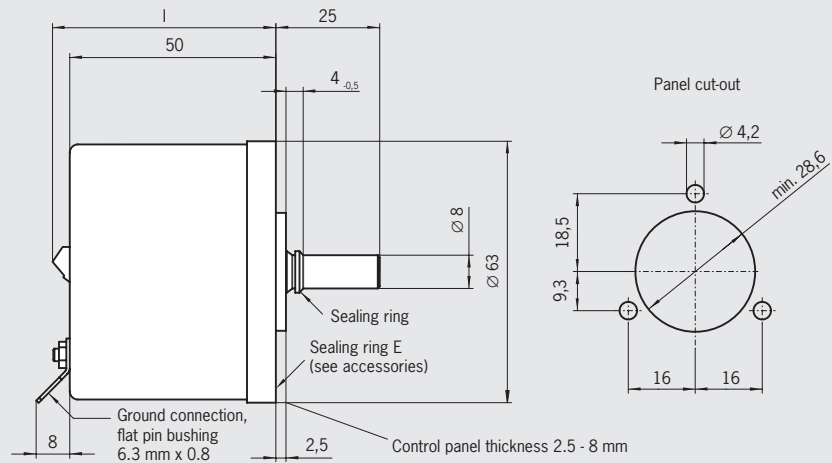

Ordering table

Series	Number of pulses per revolution	Connection	Detent positions	Outputs	Order No./item
HKD	25	S Screw terminal	100	G12 Push-pull 5 V $U_B = 10 \dots 30 \text{ V DC}$	091525 HKD025S100G12
		V Ribbon cable 6-pin with plug	100	G12 Push-pull 5 V $U_B = 10 \dots 30 \text{ V DC}$	091526 HKD025V100G12
	100	S Screw terminal	100	A05 RS422A $U_B = 5 \text{ V DC}$	054866 HKD100S100A05
				G05 Push-pull 5 V $U_B = 5 \text{ V DC}$	083354 HKD100S100G05
				G24 Push-pull 10...30 V $U_B = 10 \dots 30 \text{ V DC}$	054868 HKD100S100G24
		V Ribbon cable 6-pin with plug	100	A05 RS422A $U_B = 5 \text{ V DC}$	057036 HKD100V100A05
				G05 Push-pull 5 V $U_B = 5 \text{ V DC}$	091527 HKD100V100G05
				G24 Push-pull 10...30 V $U_B = 10 \dots 30 \text{ V DC}$	057037 HKD100V100G24

Technical data

Parameter	Value		Unit
Pulses per revolution	2 x 25 or 2 x 100		
Detent positions	100		
Housing material	Aluminum		
Weight	0.5		kg
Detent mechanism	Magnetic		
Shaft loading, axial, max.	25		N
Shaft loading, radial, max.	40		N
Mechanical life, min.	20 x 10 ⁶		Rev.
Operating temperature	0 ... +70		°C
Storage temperature	-25 ... +85		°C
Atmospheric humidity, max.	80% (condensation not permissible)		
Front degree of protection	acc. to EN 60529/IEC 529	IP 65	
	acc. to NEMA 250	250-12	
Resistance to vibration			
Vibrations (3 axes)	DIN/IEC 68-2-6		
Shock (3 axes)	DIN/IEC 68-2-27		
EMC protection requirements in accordance with CE	EN 61000-6-2, EN 61000-6-4		
Output circuit RS422A			
Output stage	A05		
Output signals	A, /A, B, /B		
Operating voltage U _B	5 ± 5 %		V DC
Operating current, no load, max.	80		mA
Output circuit	According to RS422A, use RS422 differential receiver module		
Output signals cw (clockwise rotation)	<div style="display: flex; justify-content: space-around;"> <div style="text-align: center;"> <p>25 pulses</p> <p>Detent position areas</p> </div> <div style="text-align: center;"> <p>100 pulses</p> <p>Detent position area</p> </div> </div>		
Terminal assignment	<div style="display: flex; justify-content: space-around;"> <div style="text-align: center;"> <p>Ribbon cable V</p> </div> <div style="text-align: center;"> <p>Screw terminal S</p> </div> </div>		
Output circuit, push-pull			
Output stage	G05	G12	G24
Output signals	A, B		
Operating voltage U _B	5 ± 5 %	10 ... 30	
Operating current, no load, max.	80		
Output voltage			
HIGH (1), min.	4.0 V / 0 mA	4.9 V / 0 mA	-
	3.4 V / 5 mA	3.9 V / 5 mA	-
	3.0 V / 20 mA	3.6 V / 20 mA	U _B - 3 V / 20 mA
LOW (0), max.	1.3 V / 15 mA	1.3 V / 15 mA	3 V / 20 mA
Output current per output, max.	20		
Output signals cw (clockwise rotation)	<div style="display: flex; justify-content: space-around;"> <div style="text-align: center;"> <p>25 pulses</p> <p>Detent position areas</p> </div> <div style="text-align: center;"> <p>100 pulses</p> <p>Detent position area</p> </div> </div>		
Terminal assignment	<div style="display: flex; justify-content: space-around;"> <div style="text-align: center;"> <p>Ribbon cable V</p> </div> <div style="text-align: center;"> <p>Screw terminal S</p> </div> </div>		

Handwheel HWA

- ▶ 100 detent positions per revolution
- ▶ Mechanical detent mechanism
- ▶ 100 or 25 pulses per revolution
- ▶ Center point fixing



Dimension drawing

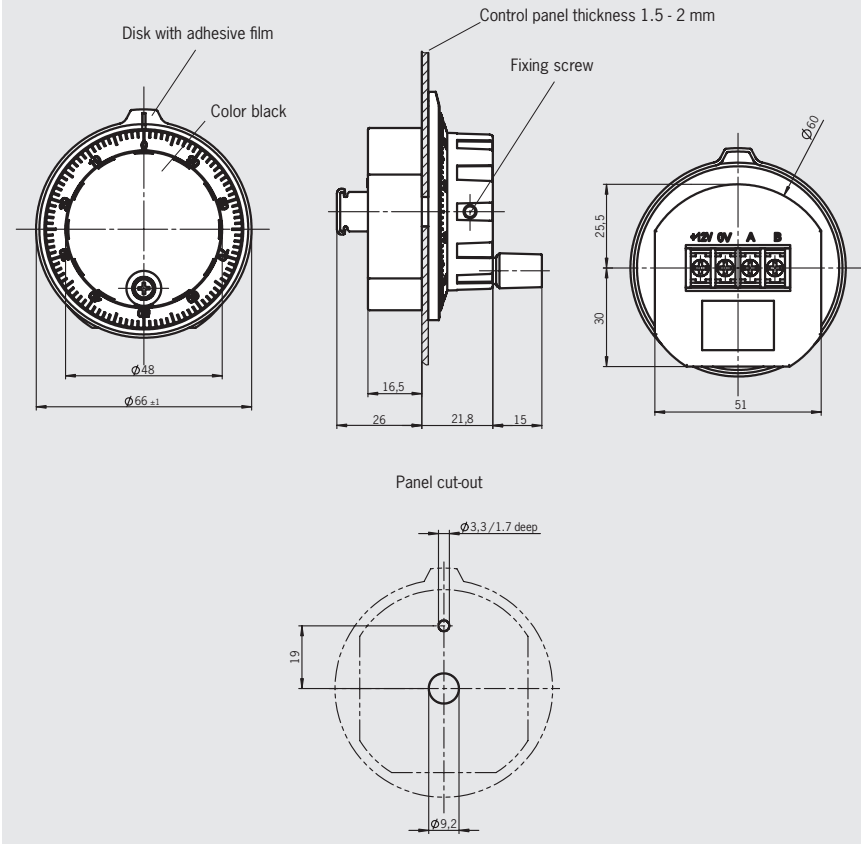





Notes

- ▶ Output A05 suitable for Siemens control systems with RS422 input
- ▶ Output G05 suitable for Fanuc control systems
- ▶ Packaging unit 10 pieces

Ordering table

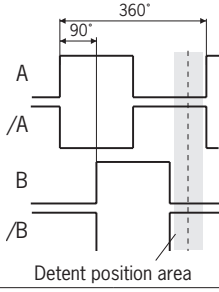
Series	Number of pulses per revolution	Connection	Detent positions	Outputs	Order No./item
HWA Packaging unit 10 ea.	25	T Screw terminal	100	G12 Push-pull 5 V U _B = 12 V DC	072972 HWA025T100G12/V10 (10 ea.)
	100	T Screw terminal	100	A05 RS422A U _B = 5 V DC	072970 HWA100T100A05/V10 (10 ea.)
				G05 Push-pull 5 V U _B = 5 V DC	072971 HWA100T100G05/V10 (10 ea.)

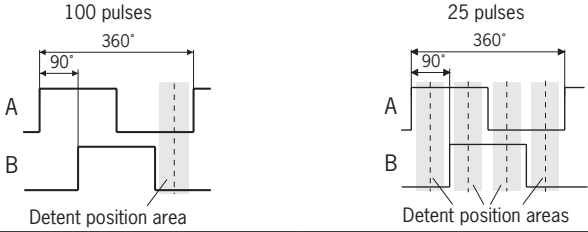
Technical data

Parameter	Value	Unit
Pulses per revolution	2 x 25 or 2 x 100	
Detent positions	100	
Housing material	Plastic/metal	
Weight	0.1	kg
Detent mechanism	Mechanical	
Shaft loading, axial, max.	25	N
Shaft loading, radial, max.	40	N
Mechanical life, min.	1 x 10 ⁶	Rev.
Operating temperature	0 ... +50	°C
Storage temperature	-20 ... +50	°C
Atmospheric humidity, max.	80% (condensation not permissible)	
Front degree of protection	acc. to EN 60529/IEC 529 acc. to NEMA 250	IP65 250-12
Output circuit RS422A		
Output stage	A05	
Output signals	A, /A, B, /B	
Operating voltage U _B	5 ± 10 %	V DC
Operating current, no load, max.	80	mA
Output specifications	According to RS422A, use RS422 differential receiver module	
Output signals cw (clockwise rotation)	100 pulses  Detent position area Screw terminal T +5V 0V A /A B /B 	
Terminal assignment		
Output circuit, push-pull		
Output stage	G05	G12
Output signals	A, B	
Operating voltage U _B	5 ± 10 %	12 ± 10 %
Operating current, no load, max.	20	
Output voltage	4.0 V / 20 mA	
	0.5 V / 20 mA	
Output current per output, max.	20	
Output signals CW (clockwise rotation)	 Detent position area Detent position areas	
Terminal assignment	Screw terminal T +U _B 0V A B 	

Handwheel HWB

- ▶ 100 detent positions per revolution
- ▶ Mechanical detent mechanism
- ▶ 100 or 25 pulses per revolution
- ▶ 3-point fixing



Dimension drawing

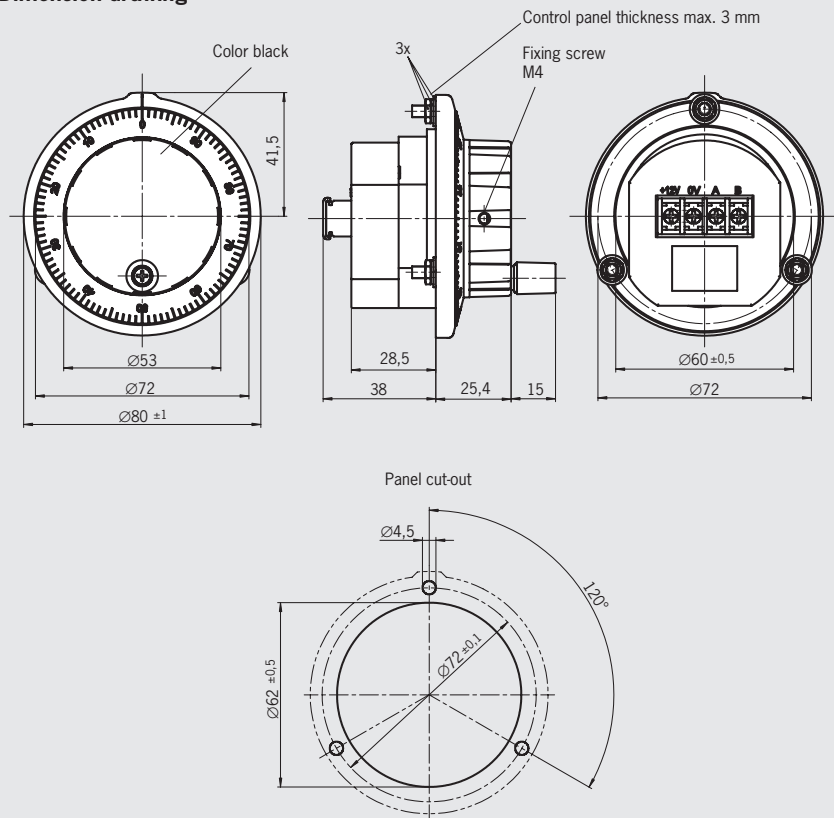





Notes

- ▶ Output A05 suitable for Siemens control systems with RS422 input
- ▶ Output G05 suitable for Fanuc control systems

Ordering table

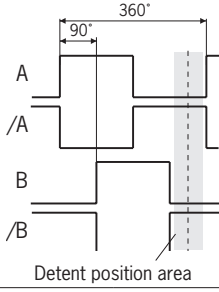
Series	Number of pulses per revolution	Connection	Detent positions	Outputs	Order No./item
HWB Packaging unit 5 ea.	25	T Screw terminal	100	G12 Push-pull 5 V U _B = 12 V DC	072975 HWB025T100G12/V05 (5 ea.)
	100	T Screw terminal	100	A05 RS422A U _B = 5 V DC	072973 HWB10T100A05/V05 (5 ea.)
				G05 Push-pull 5 V U _B = 5 V DC	072974 HWB100T100G05/V05 (5 ea.)

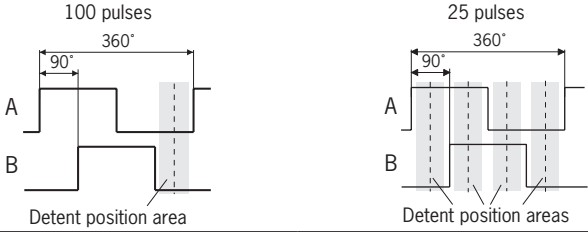
Technical data

Parameter	Value	Unit
Pulses per revolution	2 x 25 or 2 x 100	
Detent positions	100	
Housing material	Plastic/metal	
Weight	0.125	kg
Detent mechanism	Mechanical	
Shaft loading, axial, max.	25	N
Shaft loading, radial, max.	40	N
Mechanical life, min.	1 x 10 ⁶	Rev.
Operating temperature	0 ... +50	°C
Storage temperature	-20 ... +50	°C
Atmospheric humidity, max.	80% (condensation not permissible)	
Front degree of protection	acc. to EN 60529/IEC 529 acc. to NEMA 250	IP65 250-12
Output circuit RS422A		
Output stage	A05	
Output signals	A, /A, B, /B	
Operating voltage U _B	5 ± 10 %	V DC
Operating current, no load, max.	80	mA
Output specifications	According to RS422A, use RS422 differential receiver module	
Output signals CW (clockwise rotation)	100 pulses  Detent position area	
Terminal assignment	Screw terminal T +5V 0V A /A B /B 	
Output circuit, push-pull		
Output stage	G05	G12
Output signals	A, B	
Operating voltage U _B	5 ± 10 %	12 ± 10 %
Operating current, no load, max.	20	
Output voltage	4.0 V / 20 mA	
LOW (0), max.	0.5 V / 20 mA	
Output current per output, max.	20	
Output signals CW (clockwise rotation)	 Detent position area	
Terminal assignment	Screw terminal T +U _B 0V A B 	

Accessories

Front panel for handwheel HKB

- ▶ Front panel with bonded seal

Ordering table

Item	Order no.
Front panel for handwheel HKB with dial 100914, anodized silver	105072
Front panel for handwheel HKB with dial 100914, anodized black	105073

Dimension drawing

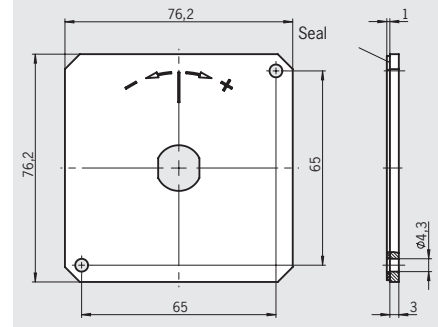

Front panel for handwheel HKD

- ▶ Front panel with bonded seal
- ▶ Seal handwheels without front panel with sealing ring E

Dimensions

Design	e	f	g	h	k	m	n	p	s	r
F	110	110	90	90	-	-	DIN74-Am5	-	-	R48
G	108	108	89	89	-	-	5.2	-	-	R48
M	76.2	76.2	-	-	65	65	4.2	-	-	R35.5

Ordering table

Item	Order no.
Sealing ring E	054861
Front panel F with seal	028760
Front panel G with seal	028761
Front panel M with seal	041758

Dimension drawing

Front panel F, G, M

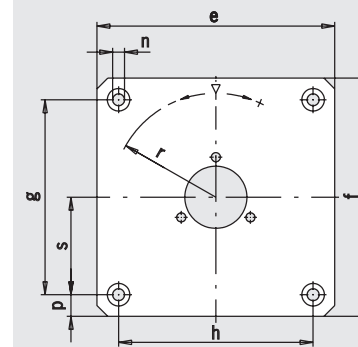

Dials for handwheel HKB

Ordering table

Item	Order no.
Dial 58 mm silver, metal with crank ¹⁾	100914
Dial 66.5 mm silver, metal with finger recess ^{1) 2)}	111992
Dial 66.5 mm black, plastic with finger recess ²⁾	105961

1) Suitable for installation in operator panels

2) For use of handwheel HKB in the kits for hand-held pendant stations HBA and HBM

Dimension drawing

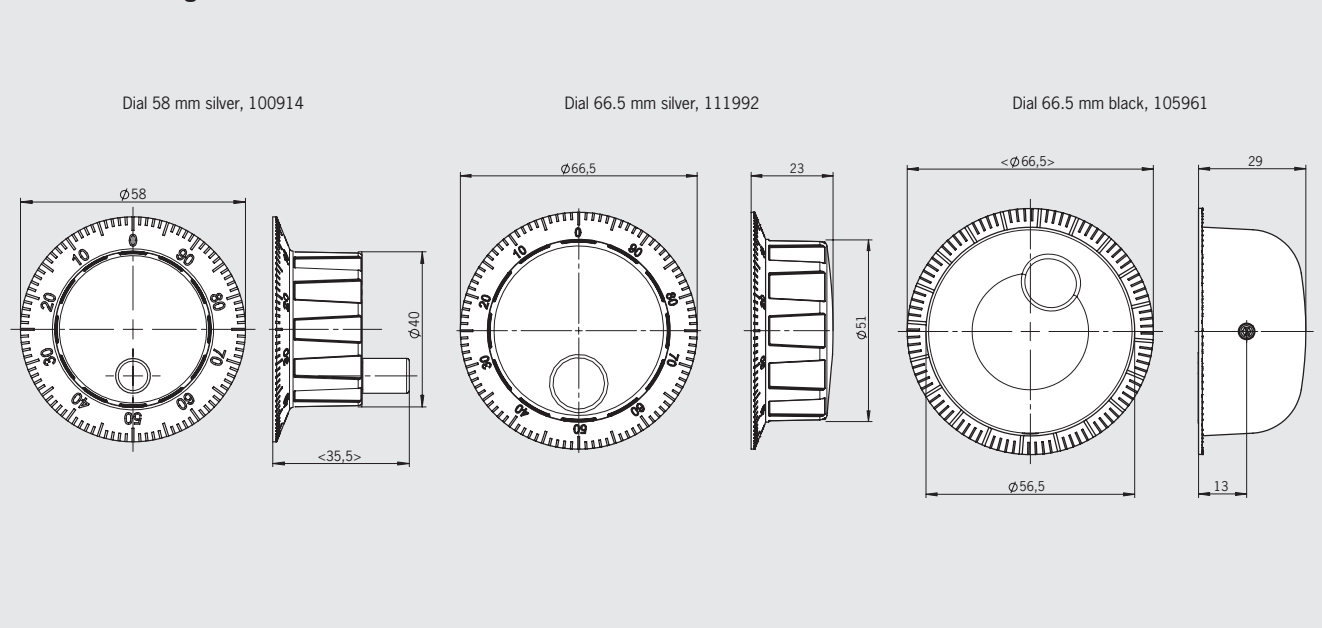

Dials for handwheel HKD

Dimensions

Design	∅ a	∅ b	c
Dial 90 mm	90	63	41
Dial 78 mm	78	63	39
Dial 75 mm	75	63	39
Dial 65 mm	65	44	42
Dial 58 mm	58	44	40

Ordering table

Item	Order no.
Dial 90 mm black	057266
Dial 90 mm silver	057268
Dial 78 mm black	057280
Dial 78 mm silver	057272
Dial 75 mm black	072633
Dial 75 mm silver	072597
Dial 65 mm black, for HBL kit	057318
Dial 65 mm silver, for HBL kit	057314
Dial 58 mm black	059276

Dimension drawing

