

PREPARED BY: <i>M. Mitsui</i>	DATE: <i>September 10, 1997</i>	<h1>SHARP</h1> <p>ELECTRONIC COMPONENTS GROUP SHARP CORPORATION</p> <h2>SPECIFICATION</h2>	SPEC. No. ED-97136
APPROVED BY: <i>J. Yoshikawa</i>	DATE: <i>Sept. 12, 1997</i>		ISSUE September 8, 1997
			PAGE 14 Pages
			REPRESENTATIVE DIVISION OPTO-ELECTRONIC DEVICES DIV.

DEVICE SPECIFICATION FOR <b>PHOTOCOUPLER</b> MODEL No.  <b>PC357</b>	Business dealing name <table border="1"> <tr><td>PC357N1T</td><td>PC357N6T</td></tr> <tr><td>PC357N2T</td><td>PC357N7T</td></tr> <tr><td>PC357N3T</td><td>PC357N8T</td></tr> <tr><td>PC357N4T</td><td>PC357N9T</td></tr> <tr><td>PC357N5T</td><td>PC357N0T</td></tr> <tr><td></td><td>PC357NT</td></tr> </table>	PC357N1T	PC357N6T	PC357N2T	PC357N7T	PC357N3T	PC357N8T	PC357N4T	PC357N9T	PC357N5T	PC357N0T		PC357NT
PC357N1T	PC357N6T												
PC357N2T	PC357N7T												
PC357N3T	PC357N8T												
PC357N4T	PC357N9T												
PC357N5T	PC357N0T												
	PC357NT												

- These specification sheets include materials protected under copyright of Sharp Corporation ("Sharp"). Please do not reproduce or cause anyone to reproduce them without Sharp's consent.
- When using this product, please observe the absolute maximum ratings and the instructions for use outlined in these specification sheets, as well as the precautions mentioned below. Sharp assumes no responsibility for any damage resulting from use of the product which does not comply with the absolute maximum ratings and the instructions included in these specification sheets, and the precautions mentioned below.
 

(Precautions)

  - This product is designed for use in the following application areas ;
 

<ul style="list-style-type: none"> <li>• OA equipment</li> <li>• Telecommunication equipment (Terminal)</li> <li>• Tooling machines</li> </ul>	<ul style="list-style-type: none"> <li>• Audio visual equipment</li> <li>• Measuring equipment</li> <li>• Computers</li> </ul>
--	--

If the use of the product in the above application areas is for equipment listed in paragraphs (2) or (3), please be sure to observe the precautions given in those respective paragraphs.
  - Appropriate measures, such as fail-safe design and redundant design considering the safety design of the overall system and equipment, should be taken to ensure reliability and safety when this product is used for equipment which demands high reliability and safety in function and precision, such as ;
 

<ul style="list-style-type: none"> <li>• Transportation control and safety equipment (aircraft, train, automobile etc.)</li> <li>• Other safety equipment</li> </ul>	<ul style="list-style-type: none"> <li>• Traffic signals</li> <li>• Gas leakage sensor breakers</li> <li>• Rescue and security equipment</li> </ul>
--	---
  - Please do not use this product for equipment which require extremely high reliability and safety in function and precision, such as ;
 

<ul style="list-style-type: none"> <li>• Space equipment</li> <li>• Nuclear power control equipment</li> </ul>	<ul style="list-style-type: none"> <li>• Telecommunication equipment (for trunk lines)</li> <li>• Medical equipment</li> </ul>
--	--
  - Please contact and consult with a Sharp sales representative if there are any questions regarding interpretation of the above three paragraphs.
- Please contact and consult with a Sharp sales representative for any questions about this product.

CUSTOMER'S APPROVAL

DATE \_\_\_\_\_  
BY \_\_\_\_\_

DATE PRESENTED BY                       
*J. M.*

T. Matsumura,  
Department General Manager of  
Engineering Dept., II  
Opto-Electronic Devices Div.  
ELECOM Group  
SHARP CORPORATION

**1. Application**

This specification applies to the outline and characteristics of photocoupler Model No. PC357.

**2. Outline**

Refer to the attached drawing No. CY9269K02.

**3. Ratings and characteristics**

Refer to the attached sheet, page 5 to 7.

**4. Reliability**

Refer to the attached sheet, page 8.

**5. Incoming inspection**

Refer to the attached sheet, page 9.

**6. Supplement**

6.1 Isolation voltage shall be measured in the following method.

- (1) Short between anode and cathode on the primary side and between collector and emitter on the secondary side.
- (2) The dielectric withstand tester with zero-cross circuit shall be used.
- (3) The wave form of applied voltage shall be a sine wave.

6.2 Packaging specifications

Refer to the attached sheet, page 10 to 12.

## 6.3 Business dealing name ("○" mark indicates business dealing name of ordered product)

Ordered product	Business dealing name	Rank mark	Ic (mA)	Test conditions
	PC357N1T	A	4.0 to 8.0	I <sub>F</sub> =5mA  V <sub>CE</sub> =5V  Ta=25°C
	PC357N2T	B	6.5 to 13	
	PC357N3T	C	10 to 20	
	PC357N4T	D	15 to 30	
	PC357N5T	A or B	4.0 to 13	
	PC357N6T	B or C	6.5 to 20	
	PC357N7T	C or D	10 to 30	
	PC357N8T	A, B or C	4.0 to 20	
	PC357N9T	B, C or D	6.5 to 30	
	PC357N0T	A, B, C or D	4.0 to 30	
○	PC357NT	A, B, C, D or no mark	2.5 to 30	

6.4 The following selection shall be made as to the collector-emitter breakdown voltage (BV<sub>CEO</sub>) in parameter 3.2.  
(Applied to lot No. "J5" [May 1997] or later)

Parameter	Symbol	Conditions	MIN.	TYP.	MAX.	Unit
Collector-emitter breakdown voltage	BV <sub>CEO</sub>	I <sub>C</sub> =0.1mA I <sub>F</sub> =0	70	-	-	V

## 6.5 This Model is approved by UL.

Approved Model No. : PC357

UL file No. : E64380

## 6.6 This product is not designed against irradiation.

This product is assembled with electrical input and output.

This product incorporates non-coherent light emitting diode.

ED-97136	September 8, 1997
MODEL No. PC357NT	PAGE 3/12

6.7 ODS materials

This device · component shall not contain the following materials.  
Also, the following materials shall not be used in the production process  
for this device · component.

Materials for ODS : CFC<sub>s</sub>, Halon, Carbon tetrachloride,  
1.1.1-Trichloroethane (Methylchloroform)

6.8 Brominated flame retardants

Specific brominated flame retardants such as the PBBO<sub>s</sub> and PBB<sub>s</sub> are not used  
in this device component at all.

7. Notes

Refer to the attached sheet-1-1, 2.

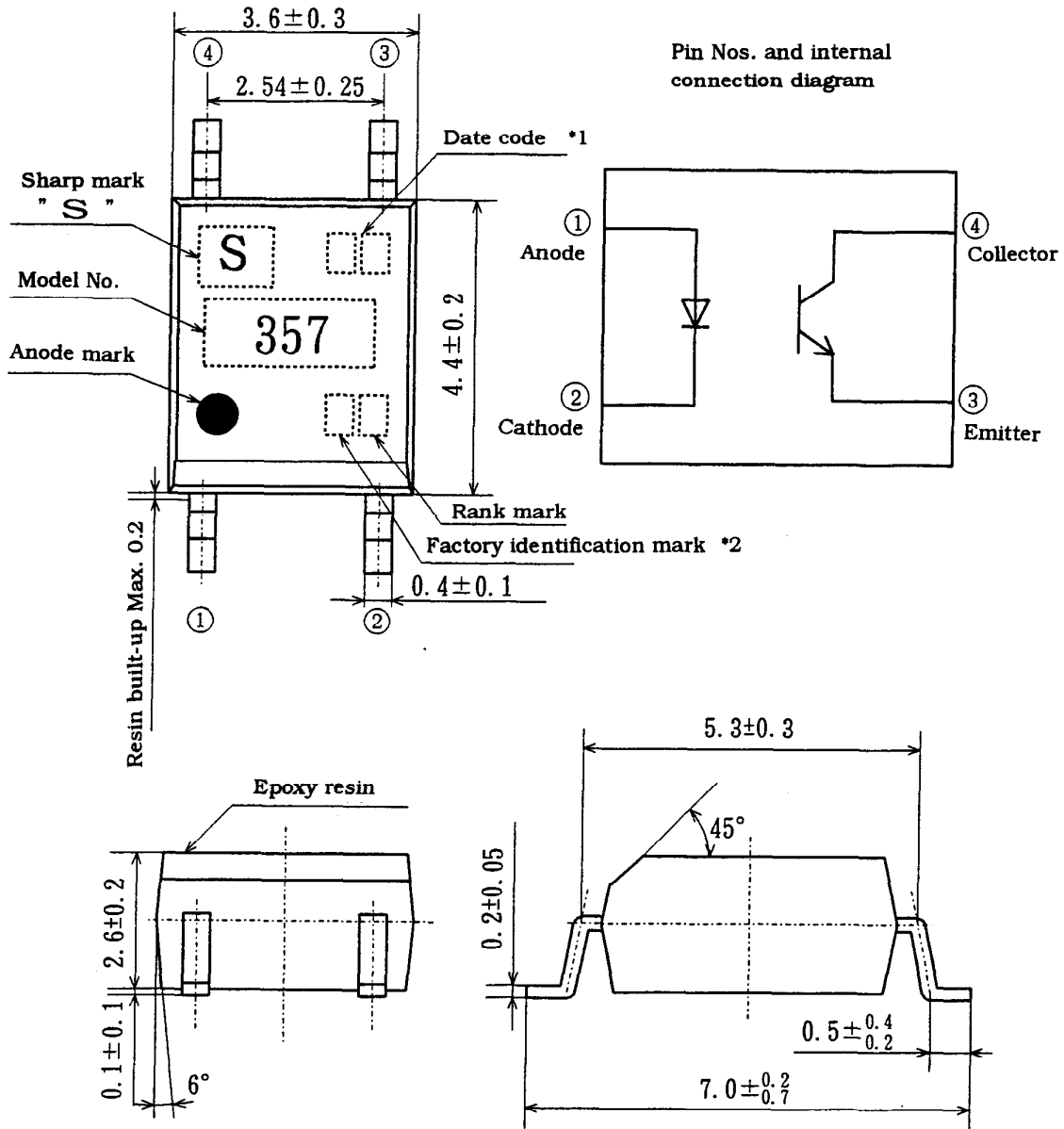

Pin Nos. and internal connection diagram

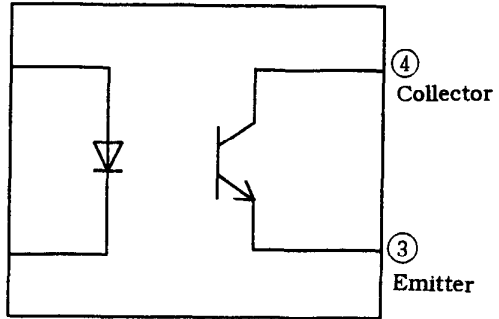

Product mass : Approx. 0.10g

- \*1) 2-digit number shall be marked according to DIN standard.
- \*2) Factory identification mark shall be or shall not be marked.
- \*3) Marking is laser marking

UNIT : 1/1 mm	
Name	PC357 Outline Dimensions (Business dealing name : PC357NT)
Drawing No.	CY9269K02

## 3. Ratings and characteristics

## 3.1 Absolute maximum ratings

Ta=25°C

	Parameter	Symbol	Rating	Unit
Input	*1 Forward current	$I_F$	50	mA
	*2 Peak forward current	$I_{FM}$	1	A
	Reverse voltage	$V_R$	6	V
	*1 Power dissipation	P	70	mW
Output	Collector-emitter voltage	$V_{CEO}$	35	V
	Emitter-collector voltage	$V_{ECO}$	6	V
	Collector current	$I_c$	50	mA
	*1 Collector power dissipation	$P_c$	150	mW
	*1 Total power dissipation	$P_{tot}$	170	mW
	Operating temperature	$T_{opr}$	-30 to +100	°C
	Storage temperature	$T_{stg}$	-40 to +125	°C
	*3 Isolation voltage	$V_{iso}$	3.75	kVrms
	*4 Soldering temperature	$T_{sol}$	260	°C

\*1 The derating factors of absolute maximum ratings due to ambient temperature are shown in Fig. 1 to 4.

\*2 Pulse width  $\leq 100 \mu s$ , Duty ratio : 0.001 (Refer to Fig. 5)

\*3 AC for 1 min, 40 to 60%RH, f=60Hz

\*4 For 10 s

## 3.2 Electro-optical characteristics

Ta=25°C

Parameter		Symbol	Conditions	MIN.	TYP.	MAX.	Unit
Input	Forward voltage	$V_F$	$I_F=20\text{mA}$	-	1.2	1.4	V
	Reverse current	$I_R$	$V_R=4\text{V}$	-	-	10	$\mu\text{A}$
	Terminal capacitance	$C_t$	$V=0, f=1\text{kHz}$	-	30	250	pF
Output	Dark current	$I_{CEO}$	$V_{CE}=20\text{V}, I_F=0$	-	-	100	nA
	Collector-emitter breakdown voltage	$BV_{CEO}$	$I_c=0.1\text{mA}$ $I_F=0$	35	-	-	V
	Emitter-collector breakdown voltage	$BV_{ECO}$	$I_E=10\mu\text{A}, I_F=0$	6	-	-	V
Transfer characteristics	Collector current	$I_c$	$I_F=5\text{mA}, V_{CE}=5\text{V}$	2.5	5	30	mA
	Collector-emitter saturation voltage	$V_{CE(sat)}$	$I_F=20\text{mA}$ $I_c=1\text{mA}$	-	0.1	0.2	V
	Isolation resistance	$R_{iso}$	DC500V 40 to 60%RH	$5 \times 10^{10}$	$10^{11}$	-	$\Omega$
	Floating capacitance	$C_f$	$V=0, f=1\text{MHz}$	-	0.6	1.0	pF
	Response time (Rise)	$t_r$	$V_{CE}=2\text{V}$ $I_c=2\text{mA}$	-	4	18	$\mu\text{s}$
	Response time (Fall)	$t_f$	$R_L=100\Omega$	-	3	18	$\mu\text{s}$

(Fig. 1) Forward current vs. ambient temperature

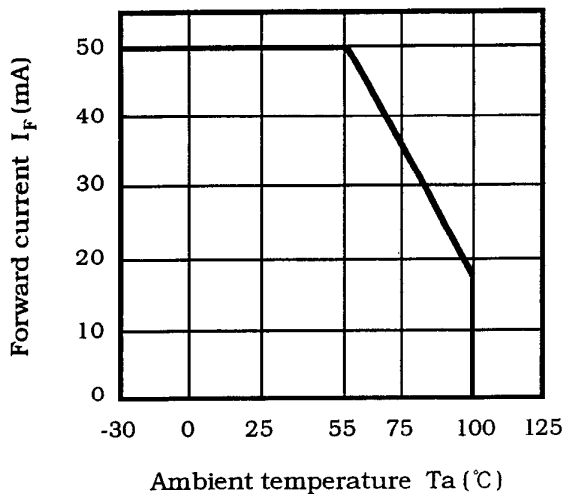

(Fig. 2) Diode power dissipation vs. ambient temperature

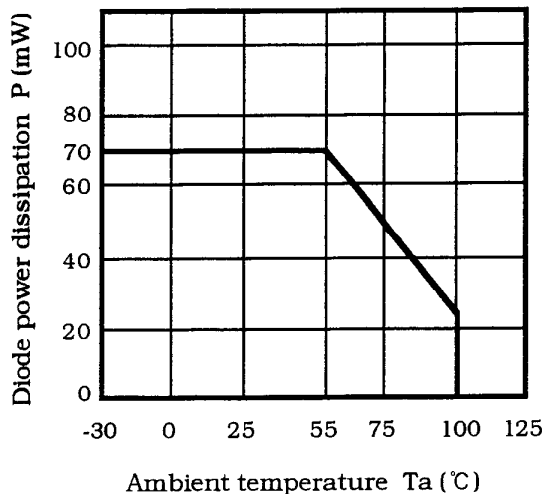

(Fig. 3) Collector power dissipation vs. ambient temperature

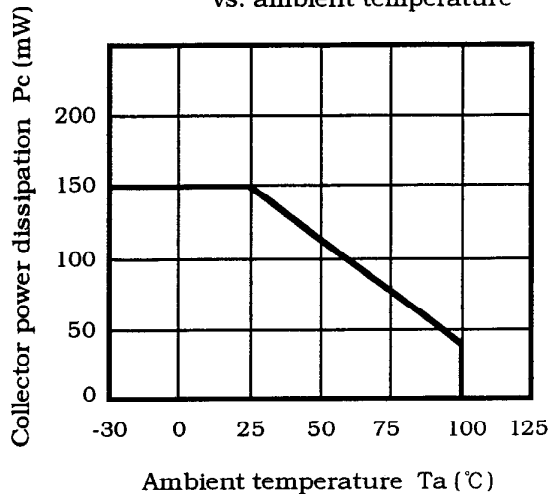

(Fig. 4) Total power dissipation vs. ambient temperature

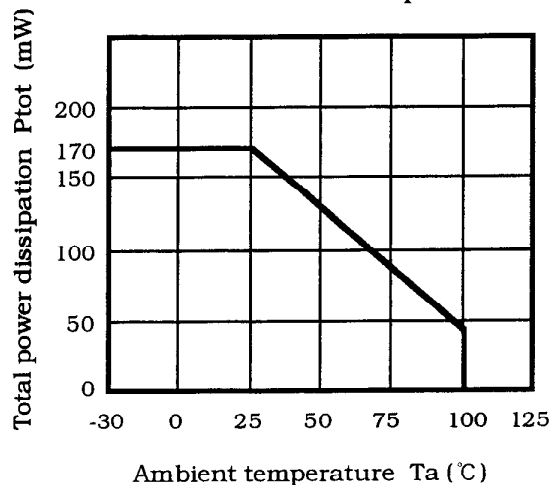

(Fig. 5) Peak forward current vs. duty ratio

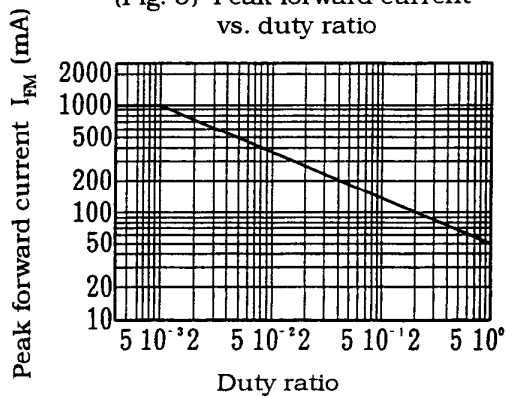

Pulse width ≤ 100 μs  
Ta = 25°C



4. Reliability

The reliability of products shall satisfy items listed below.

Confidence level : 90%  
LTPD : 10%/20%

Test Items	Test Conditions *1	Failure Judgement Criteria	Samples (n) Defective(C)
Solderability *2	230°C, 5 s	—	n=11, C=0
Soldering heat *3	260°C, 10 s	$V_F > U \times 1.2$	n=11, C=0
Terminal strength (Bending) *4	Weight : 1N 1 time/each terminal	$I_R > U \times 2$	n=11, C=0
Mechanical shock	15000m/s <sup>2</sup> , 0.5ms 3 times / ±X, ±Y, ±Z direction	$I_{CEO} > U \times 2$ $I_C < L \times 0.7$	n=11, C=0
Variable frequency vibration	100 to 2000 to 100Hz/4min 200m/s <sup>2</sup> 4 times / X, Y, Z direction	$V_{CE(sat)} > U \times 1.2$	n=11, C=0
Temperature cycling	1 cycle -40°C to +125°C (30min) (30min) 20 cycles test		n=22, C=0
High temp. and high humidity storage	+85°C, 85%RH, 500h *5	U : Upper specification limit	n=22, C=0
High temp. storage	+125°C, 1000h	L : Lower specification limit	n=22, C=0
Low temp. storage	-40°C, 1000h		n=22, C=0
Operation life	$I_F = 50\text{mA}$ , $P_{tot} = 170\text{mW}$ $T_a = 25^\circ\text{C}$ , 1000h		n=22, C=0

\*1 Test method, conforms to JIS C 7021.

\*2 Solder shall adhere at the area of 95% or more of immersed portion of lead, and pin hole or other holes shall not be concentrated on one portion.

\*3 The lead pin depth dipped into solder shall be 0.2mm away from the root of lead pins.

\*4 Terminal bending direction is shown below.

\*5 It is evaluated after washing by specified solvent in attach sheet-1-1, 2.

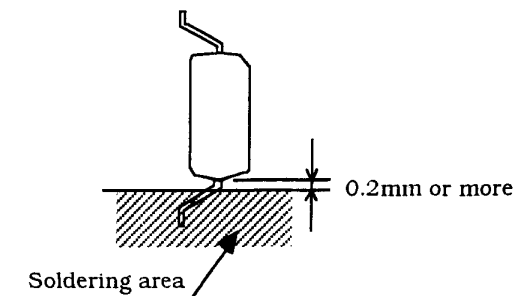
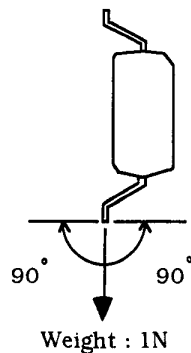

## 5. Incoming inspection

### 5.1 Inspection items

#### (1) Electrical characteristics

$V_F$ ,  $I_R$ ,  $I_{CEO}$ ,  $V_{CE(sat)}$ ,  $I_c$ ,  $R_{iso}$ ,  $V_{iso}$

#### (2) Appearance

### 5.2 Sampling method and Inspection level

A single sampling plan, normal inspection level II based on ISO 2859 is applied. The AQL according to the inspection items are shown below.

Defect	Inspection item	AQL (%)
Major defect	Electrical characteristics Unreadable marking	0.1
Minor defect	Appearance defect except the above mentioned.	0.4

## 6.2 Package specifications

### 6.2.1 Taping conditions

- (1) Tape structure and Dimensions (Refer to the attached sheet, Page 10)

The tape shall have a structure in which a cover tape is sealed heat-pressed on the carrier tape of protect against static electricity.

- (2) Reel structure and Dimensions (Refer to the attached sheet, Page 11)

The taping reel shall be of plastic with its dimensions as shown in the attached drawing.

- (3) Direction of product insertion (Refer to the attached sheet, Page 11)

Product direction in carrier tape shall direct to the anode mark at the hole side on the tape.

- (4) Joint of tape

The cover tape and carrier tape in one reel shall be jointless.

- (5) The way to repair taped failure devices

The way to repair taped failure devices cut a bottom of carrier tape with a cutter, and after replacing to good devices, the cut portion shall be sealed with adhesive tape.

### 6.2.2 Adhesiveness of cover tape

- The exfoliation force between carrier tape and cover tape shall be 0.2N to 0.7N for the angle from 160° to 180° .

### 6.2.3 Rolling method and quantity

- Wind the tape back on the reel so that the cover tape will be outside the tape. Attach more than 20cm of blank tape to the trailer and the leader of the tape and fix the both ends with adhesive tape. One reel shall contain 750pcs.

### 6.2.4 Marking

- The outer packaging case shall be marked with following information.
  - \* Model No. \* Number of pieces delivered \* Production date

### 6.2.5 Storage condition

- Taped products shall be stored at the temperature between 5 and 30°C and the humidities lower than 70%RH.

### 6.2.6 Safety protection during shipping

- There shall be no deformation of component or degradation of electrical characteristics due to shipping.

Carrier tape structure and Dimensions

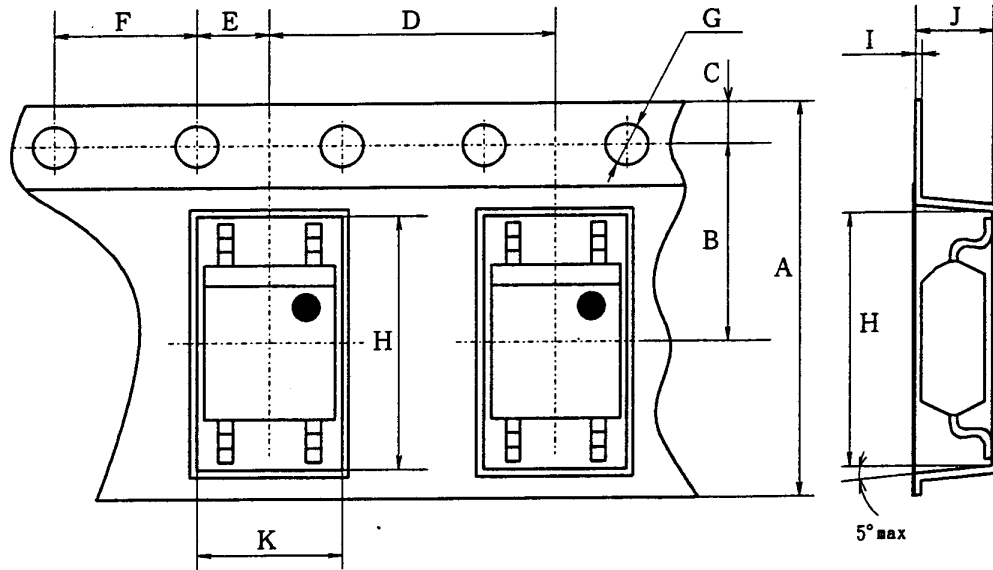

Symbol	A	B	C	D	E
Unit					
mm	±0.3 12.0	±0.05 5.5	±0.1 1.75	±0.1 8.0	±0.05 2.0

Symbol	F	G	H	I	J	K
Unit						
mm	±0.1 4.0	+0.1 -0.0 φ 1.5	±0.1 7.4	±0.05 0.3	±0.1 3.1	±0.1 4.0

Reel structure and Dimensions

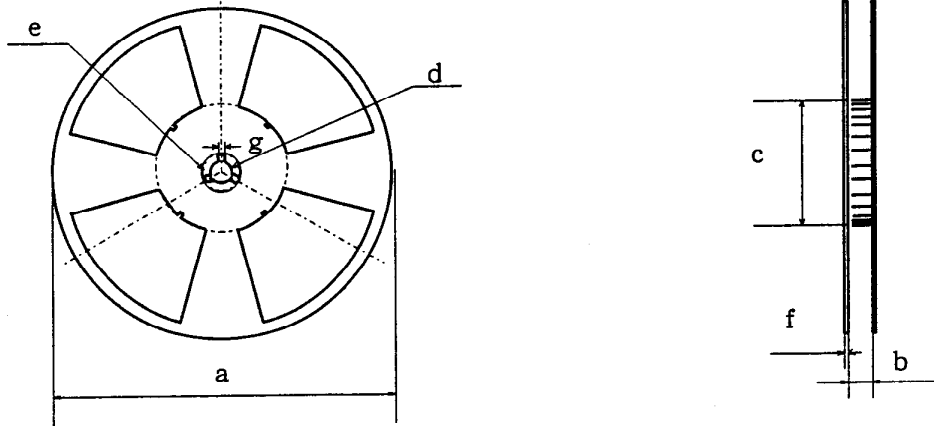

Symbol Unit	Check word						
	a	b	c	d	e	f	g
mm	180	13.5±1.5	80±1.0	13±0.5	21±1.0	2.0±0.5	2.0±0.5

Direction of product insertion

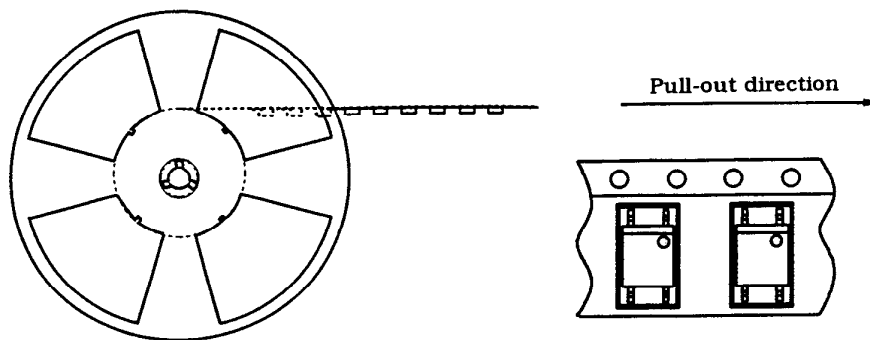

Precautions for Photocouplers

## 1 For cleaning

- (1) Solvent cleaning : Solvent temperature 45°C or less  
Immersion for 3 min or less
- (2) Ultrasonic cleaning : The effect to device by ultrasonic cleaning- differs by cleaning bath size, ultrasonic power output, cleaning time, PWB size or device mounting condition etc. Please test it in actual using condition and confirm that doesn't occur any defect before starting the ultrasonic cleaning.

Applicable solvent : Ethyl alcohol, Methyl alcohol, Freon TE · TF  
Diflon-solvent S3-E, Trichloroethane

Please refrain from using Chloro Fluoro Carbon type solvent to clean devices as much as possible since it is internationally restricted to protect the ozonosphere. Before you use alternative solvent you are requested to confirm that it does not attack package resin. In case of using trichloroethane in this device by dry up (100°C, for 30 to 60min) after washing.

2. The LED used in the Photocoupler generally decreases the light emission power by operation. In case of long operation time, please design the circuit with considering the degradation of the light emission power of the LED. (50%/5years)

### 3. Precautions for Soldering Photocouplers

(1) If solder reflow :

It is recommended that only one soldering be done at the temperature and the time within the temperature profile as shown in the figure below.

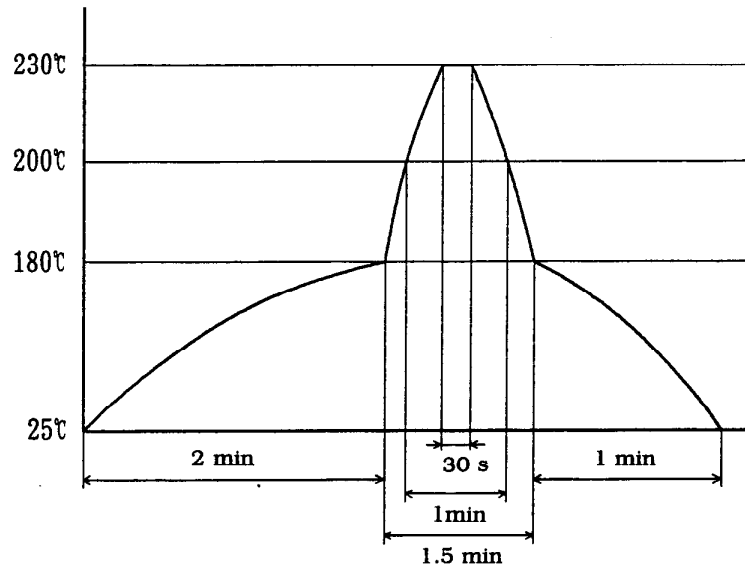

Since, influence to the device is different according to reflow equipment and its condition, please use the device after confirming no damage in the actual using condition.

(2) Other precautions

An infrared lamp used to heat up for soldering may cause a localized temperature rise in the resin. So keep the package temperature within that specified in Item (1). Also avoid immersing the resin part in the solder.