

## Resolver



### RE-15

- Hollow shaft  $\varnothing$ : 12 mm max.
- Outer  $\varnothing$ : 36.8 mm
- Length: 16 mm



### RE-21

- Hollow shaft  $\varnothing$ : 17 mm max.
- Outer  $\varnothing$ : 52.4 mm
- Length: 26 mm

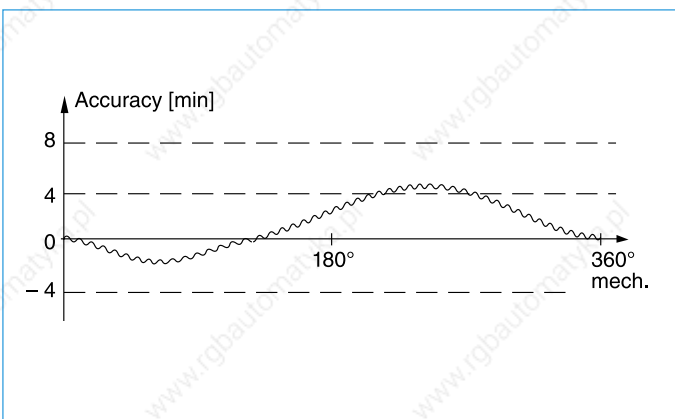

### Main features

- Operating temperature:  $-55^{\circ}\text{C} \dots +155^{\circ}\text{C}$
- Permissible speed: 20,000 rpm max.
- Accuracy absolute:  $\pm 4' / \pm 6' / \pm 10'$
- Accuracy ripple: 1' max.
- Rotor and stator completely impregnated
- 1/2/3/4 pole pairs

LTN Servotechnik GmbH

## Operating Principle

A resolver is a rotary transformer that provides information on the rotor position angle  $\theta$ .

The stator bobbin winding is energized with an AC voltage  $E_{R1-R2}$ . This AC voltage is transferred to the rotor winding with transformation ratio  $Tr$ .

The AC voltage then induces the voltages  $E_{S1-S3}$  and  $E_{S2-S4}$  into the two output windings of the stator.

The magnitude of the output voltages vary with the sine and the cosine of the rotor position angle  $\theta$ , because the two secondary windings are shifted by  $90^\circ$ .

Input:  $E_{R1-R2}$   
 Output:  $E_{S1-S3}$   
 $E_{S2-S4}$

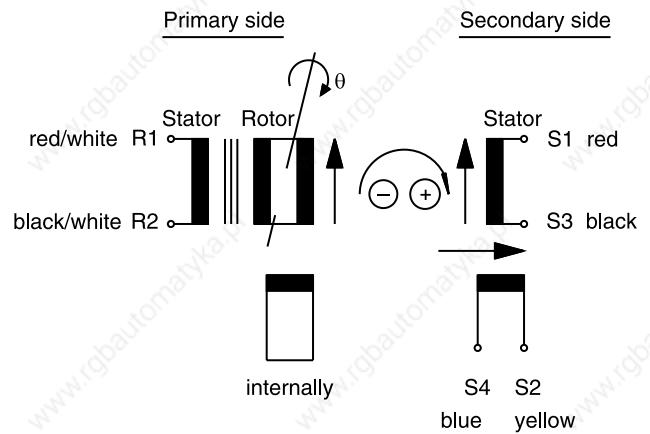

Input Signal:  
 $E_{R1-R2} = E_0 \sin(\omega t)$

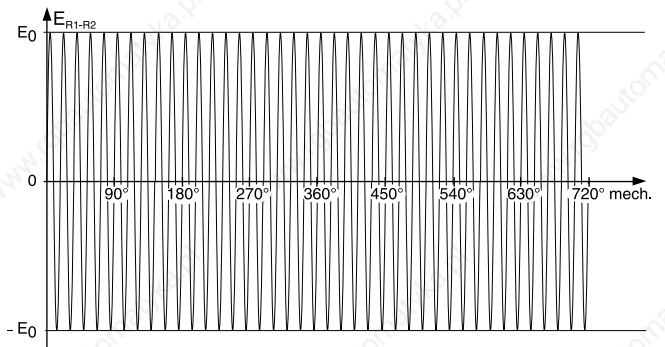

Output Signal:  
 $E_{S1-S3} = Tr \cdot E_{R1-R2} \cdot \cos\theta$

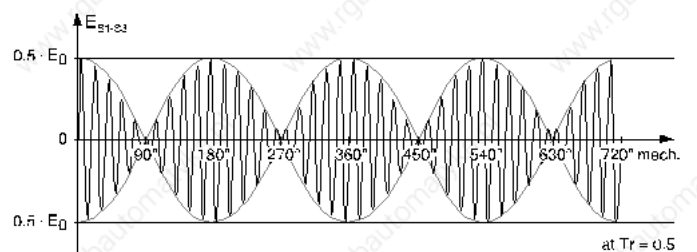

Output Signal:  
 $E_{S2-S4} = Tr \cdot E_{R1-R2} \cdot \sin\theta$

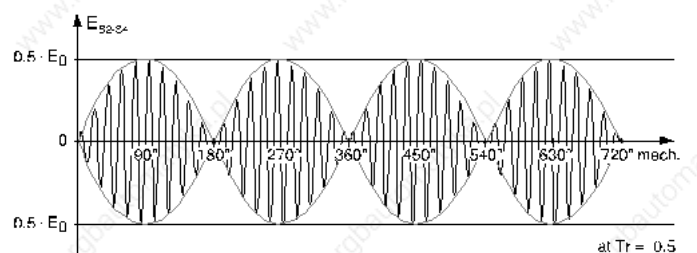

LTN Servotechnik GmbH

## Accuracy

The accuracy  $\varepsilon$  is defined as the difference between the electrical angle  $\theta_{el}$ , indicated by the output voltages of the secondary windings, and the mechanical angle or rotor position angle  $\theta_{mech}$ .

$$\text{accuracy } (\varepsilon) = \text{electrical angle } (\theta_{el}) - \text{mechanical angle } (\theta_{mech})$$

For each LTN resolver the accuracy is indicated in the data sheet by the terms 'accuracy absolute', 'accuracy spread' and 'accuracy ripple'.

The 'accuracy absolute' or the 'accuracy spread' is caused by the internal error of the resolver and the mounting error resulting in 1st and 2nd order harmonics of the sinusoidal signal.

At low speeds the 'accuracy ripple' effects the speed stability of a drive. This ripple is caused by 3rd and higher order harmonics. To ensure smooth drive performance even at low speeds LTN resolvers have an accuracy ripple of less than 1'. It is achieved by a patented procedure of stepping two lamination assemblies in the rotor.

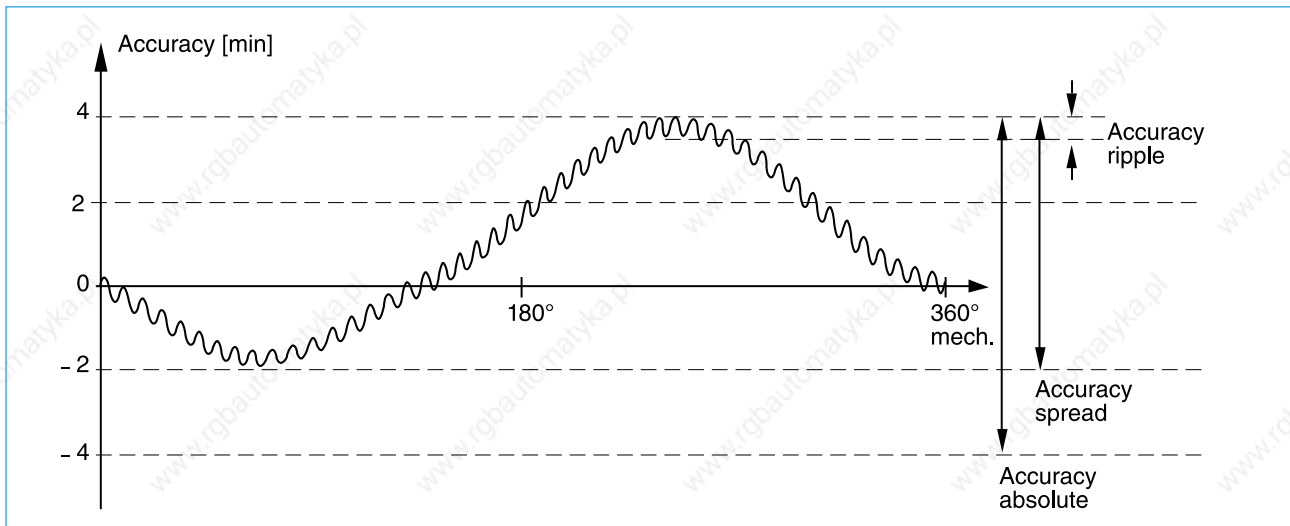

Straight lamination assembly:

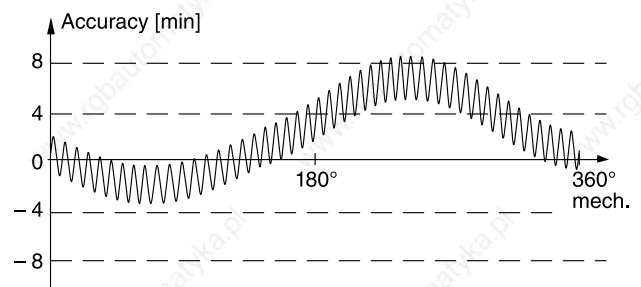
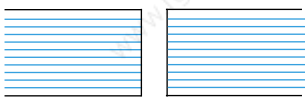

Stepped lamination assembly: (LTN patent)

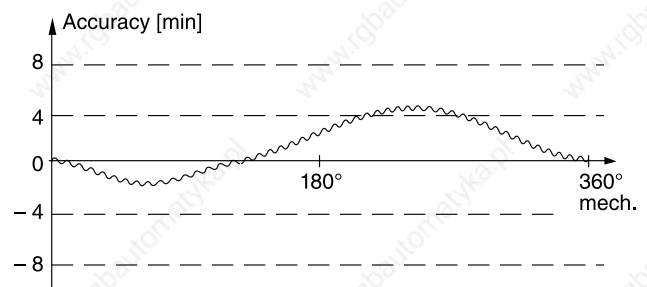
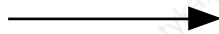
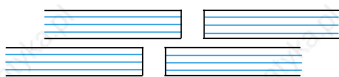

LTN Servotechnik GmbH

## Resolver RE-15: Selection Guide for Electrical Data

Various mechanical versions available

Basic Model	RE-15-1-A14		RE-15-1-K01		RE-15-1-V07		RE-15-3-D04		RE-15-4-D04	
Primary Side	R1 – R2									
Pole Pairs	1					3		4		
Transformation Ratio	0.5 ± 0.05									
Input Voltage	7 V <sub>rms</sub>	7 V <sub>rms</sub>	5 V <sub>rms</sub>	5 V <sub>rms</sub>	7 V <sub>rms</sub>	7 V <sub>rms</sub>	7 V <sub>rms</sub>	7 V <sub>rms</sub>	7 V <sub>rms</sub>	7 V <sub>rms</sub>
Input Current	58 mA	36 mA	48 mA	17 mA	58 mA	36 mA	50 mA	24 mA	16 mA	10 mA
Input Frequency	5 kHz	10 kHz	1 kHz	4.5 kHz	5 kHz	10 kHz	4 kHz	10 kHz	5 kHz	10 kHz
Phase Shift (± 3°)	8°	-6°	26°	0°	8°	-6°	15°	0°	15°	1°
Null Voltage	30 mV max.									
Impedance										
Z <sub>ro</sub> in Ω	75 j 98	110 j 159	55 j 87	164 j 255	75 j 98	110 j 159	74 j 120	145 j 250	208 j 393	319 j 657
Z <sub>rs</sub> in Ω	70 j 85	96 j 150	62 j 81	145 j 210	70 j 85	96 j 150	78 j 110	135 j 240	207 j 375	306 j 636
Z <sub>so</sub> in Ω	180 j 230	245 j 400	248 j 105	315 j 340	180 j 230	245 j 400	430 j 450	570 j 1030	831 j 2496	939 j 4272
Z <sub>ss</sub> in Ω	170 j 200	216 j 370	256 j 88	278 j 280	170 j 200	216 j 370	435 j 410	535 j 970	840 j 2396	899 j 4145
D.C. Resistance (± 10%)										
Rotor	40 Ω		17.5 Ω		40 Ω		34 Ω		58 Ω	
Stator	102 Ω		200 Ω		102 Ω		380 Ω		659 Ω	
Accuracy	±10', ±6' on request				± 4'		± 5'		± 6'	
Accuracy Ripple	1' max.					3' max.		3' max.		
Operating Temperature	-55°C ... +155°C									
Max. Permissible Speed	20,000 rpm									
Shock (11 ms)	≤ 1000 m/s <sup>2</sup>									
Vibration (10 to 500 Hz)	≤ 500 m/s <sup>2</sup>									
Weight Rotor/Stator	25 g / 60 g		25 g / 70 g		25 g / 60 g		25 g / 60 g		25 g / 60 g	
Rotor Moment of Inertia	0.02 × 10 <sup>-4</sup> kgm <sup>2</sup>									
Hi-pot Housing/Winding	500 V min.									
Hi-pot Winding/Winding	250 V min.									
Rotor	Completely impregnated									
Stator	Completely impregnated									
Length of stator	16.1 mm		21.3 mm		20.0 mm		16.1 mm		16.1 mm	

The selection guide and the mounting dimensions contain a sample of resolvers designed and manufactured by LTN. The performance parameters and mechanical dimensions can also be used as a guideline for new mechanical or electrical designs to satisfy your future requirements with an innovative, cost effective solution.

Housed bearing-type resolvers are also designed and manufactured by LTN, but not subject to this data sheet. Please contact us for further information.

LTN Servotechnik GmbH

# Resolver RE-15: Mounting Dimensions



## RE-15-1: Version A/B

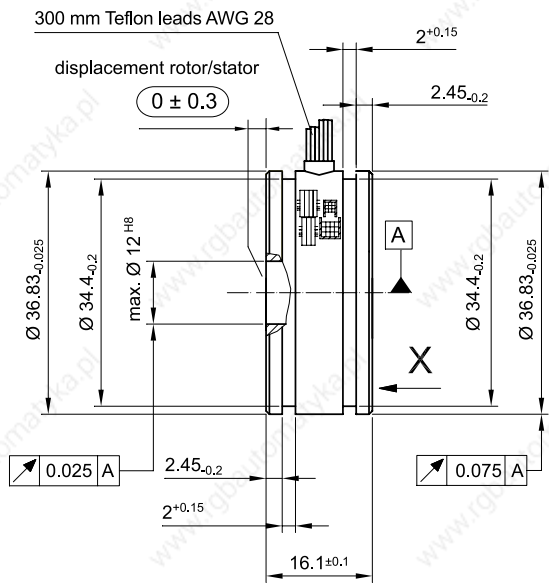

Inner diameter stator = 22.800 min.  
Outer diameter rotor = 22.325 max.

Positive counting direction:  
Rotor cw as viewed from bobbin end (X ←)

Dimensions in mm

## RE-15-1: Version C/D

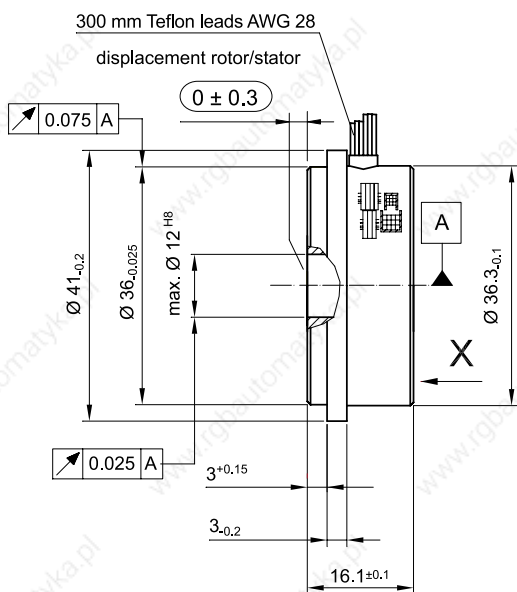

Inner diameter stator = 22.800 min.  
Outer diameter rotor = 22.325 max.

Positive counting direction:  
Rotor cw as viewed from bobbin end (X ←)

Dimensions in mm

LTN Servotechnik GmbH

## Resolver RE-21: Selection Guide for Electrical Data

Various mechanical versions available

Basic Model	RE-21-1-A01		RE-21-1-A06		RE-21-1-A05		RE-21-1-K05		RE-21-3-A03	
Primary Side	R1 – R2									
Pole Pairs	1								3	
Transformation Ratio	1.0 ± 0.1		0.5 ± 0.05							
Input Voltage	7 V <sub>rms</sub>	7 V <sub>rms</sub>	7 V <sub>rms</sub>	7 V <sub>rms</sub>	7 V <sub>rms</sub>	7 V <sub>rms</sub>	5 V <sub>rms</sub>	5 V <sub>rms</sub>	7 V <sub>rms</sub>	7 V <sub>rms</sub>
Input Current	40 mA	30 mA	47 mA	30 mA	70 mA	56 mA	32 mA	17 mA	70 mA	40 mA
Input Frequency	5 kHz	10 kHz	5 kHz	10 kHz	5 kHz	7 kHz	1 kHz	4,5 kHz	5 kHz	10 kHz
Phase Shift (± 3°)	11°	-7.5°	8°	-8°	6°	-3°	26°	-6°	12°	1°
Null Voltage	30 mV max.									
Impedance										
Z <sub>ro</sub> in Ω	133 j 115	170 j 200	92 j 120	122 j 203	78 j 84	88 j 108	86 j 108	180 j 375	55 j 85	77 j 154
Z <sub>rs</sub> in Ω	122 j 105	149 j 190	82 j 100	103 j 185	70 j 75	76 j 100	92 j 95	150 j 330	53 j 80	71 j 145
Z <sub>so</sub> in Ω	800 j 1454	1310 j 2400	154 j 275	245 j 454	114 j 205	138 j 263	195 j 210	390 j 695	105 j 335	175 j 624
Z <sub>ss</sub> in Ω	740 j 1230	1150 j 2270	140 j 240	202 j 415	101 j 184	117 j 243	205 j 178	325 j 615	104 j 312	160 j 590
D. C. Resistance (± 10°)										
Rotor	90 Ω		56 Ω		48 Ω		47 Ω		34 Ω	
Stator	260 Ω		53 Ω		31 Ω		143 Ω		58 Ω	
Accuracy	±6', ±4' on request									
Accuracy Ripple	1' max.									
Operating Temperature	-55°C ... +155°C									
Max. Permissible Speed	20,000 rpm									
Shock (11 ms)	≤ 1000 m/s <sup>2</sup>									
Vibration (10 to 500 Hz)	≤ 500 m/s <sup>2</sup>									
Weight Rotor/Stator	90 g / 200 g									
Rotor Moment of Inertia	0.14 × 10 <sup>-4</sup> kgm <sup>2</sup>									
Hi-pot Housing/Winding	500 V min.									
Hi-pot Winding/Winding	250 V min.									
Rotor	Completely impregnated									
Stator	Completely impregnated									
Length of stator	25.6 mm									

The selection guide and the mounting dimensions contain a sample of resolvers designed and manufactured by LTN. The performance parameters and mechanical dimensions can also be used as a guideline for new mechanical or electrical designs to satisfy your future requirements with an innovative, cost effective solution.

Housed bearing-type resolvers are also designed and manufactured by LTN, but not subject to this data sheet. Please contact us for further information.



LTN Servotechnik GmbH

## Resolver RE-21: Mounting Dimensions



### RE-21-1: Version A/B

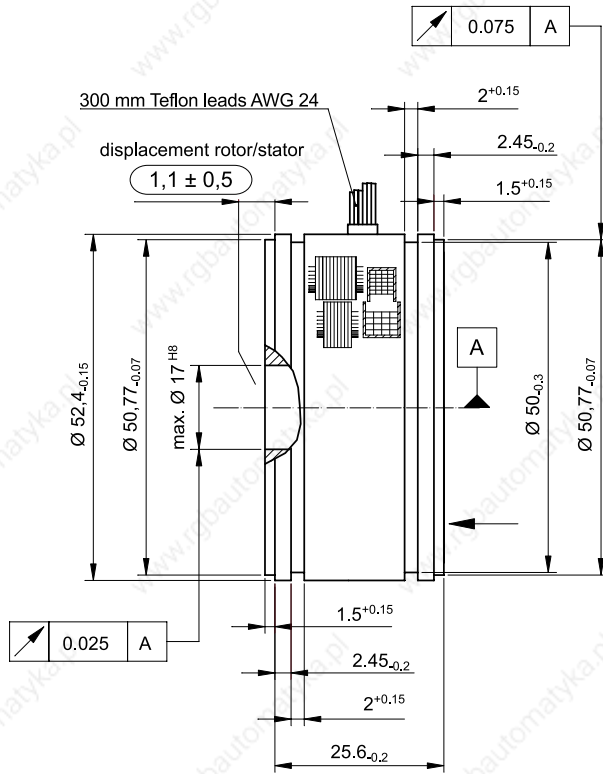

Inner diameter stator = 33.470 min.  
Outer diameter rotor = 32.735 max.

Positive counting direction:  
Rotor cw as viewed from bobbin end (X ←)

Dimensions in mm

### RE-21-1: Version C/D

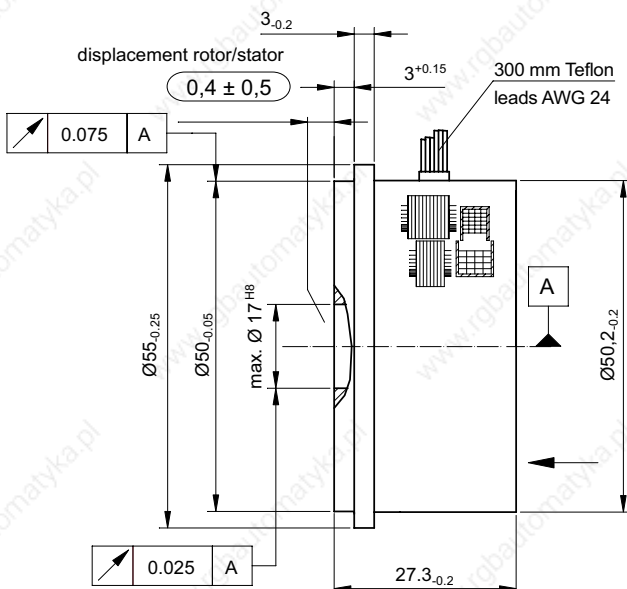

Inner diameter stator = 33.470 min.  
Outer diameter rotor = 32.735 max.

Positive counting direction:  
Rotor cw as viewed from bobbin end (X ←)

Dimensions in mm

LTN Servotechnik GmbH

### Ordering Information

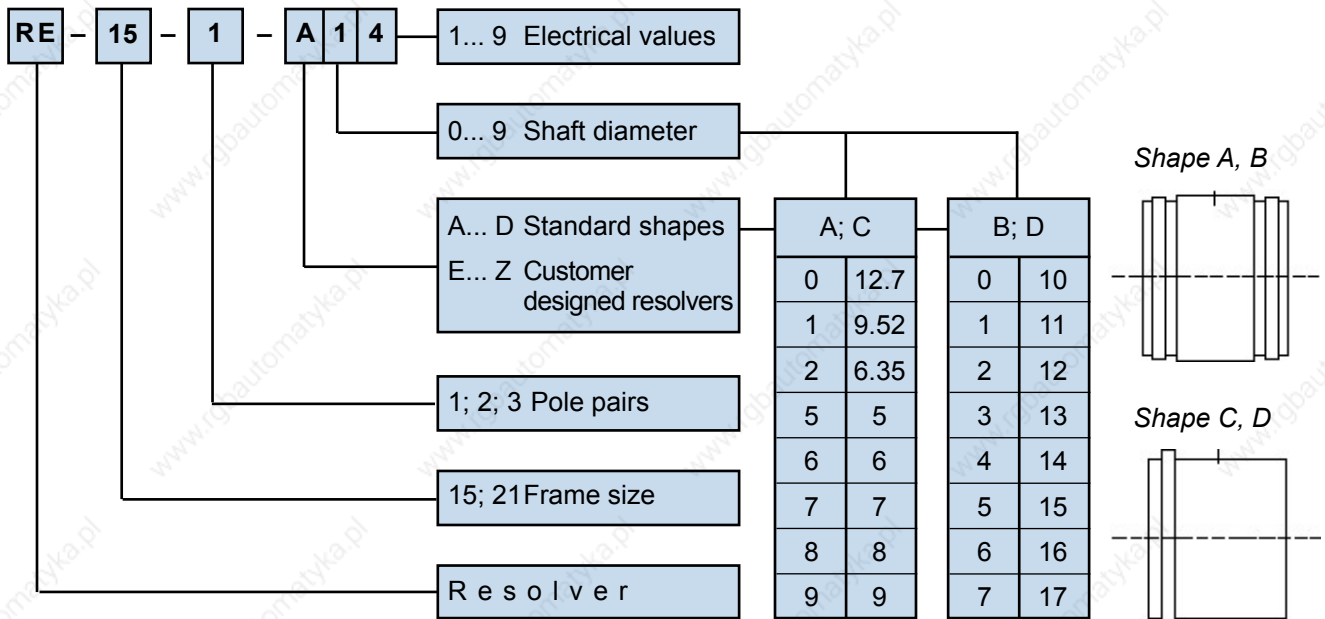

#### LTN Servotechnik GmbH

Georg-Hardt-Straße 4  
D-83624 Otterfing  
Germany

Tel: +49 - (0)8024-6080-0

Fax: +49 - (0)8024-6080-100

E-Mail: LTN@LTN.de

Internet: www.LTN.de