



# MicroLogix 1762-OB8 Solid-State 24V DC Source Output Module

Catalog Number 1762-OB8

## Table of Contents

| <b>Topic</b>                               | <b>Page</b> |
|--|-------------|
| Description                                | 3           |
| Installation                               | 4           |
| Mounting                                   | 5           |
| System Assembly                            | 7           |
| Field Wiring Connections                   | 8           |
| I/O Memory Mapping                         | 10          |
| Specifications                             | 11          |
| North American Hazardous Location Approval | 14          |

## For More Information

| Resource   | Description  |
|--|--|
| MicroLogix 1200 Programmable Controllers User Manual, publication <a href="#">1762-UM001</a> .                           | Information on installing, wiring, and operating a MicroLogix 1200 Programmable Controller |
| MicroLogix 1200 Programmable Controllers Installation Instructions, publication <a href="#">1762-IN006</a> .             | Installation guide for the MicroLogix 1200 Programmable Controller.                        |
| MicroLogix 1200 Memory Module and/or Real Time Clock Installation Instructions, publication <a href="#">1762-IN001</a> . | Installation guide for the MicroLogix 1200 Memory Module and Real Time Clock.              |
| 1762-IA8 120V AC Input Module Installation Instructions, publication <a href="#">1762-IN002</a> .                        | Installation guide for the 1762-IA8 Discrete Input Module                                  |
| 1762-OW8 Relay Output Module, publication <a href="#">1762-IN003</a> .   | Installation guide for the 1762-OW8 Relay Output Module                                    |
| 1762-IQ8 DC Input Module Installation Instructions, publication <a href="#">1762-IN004</a> .                             | Installation guide for the 1762-IQ8 Discrete Input Module                                  |
| 1762-IF20F2 Analog Input/Output Module Installation Instructions, publication <a href="#">1762-IN005</a> .               | Installation guide for the 1762-IF20F2 Analog I/O Module                                   |
| 1762-OA8 Solid-State Output Module, publication <a href="#">1762-IN007</a> .   | Installation guide for the 1762-OA8 Solid-State Output Module                              |
| Industrial Automation Wiring and Grounding Guidelines, publication <a href="#">1770-4.1</a> .                            | More information on proper wiring and grounding techniques.                                |

If you would like a manual, you can:

- download a free electronic version from the Internet: <http://literature.rockwellautomation.com>
- purchase a printed manual by contacting your local Allen-Bradley distributor or Rockwell Automation representative

## Description

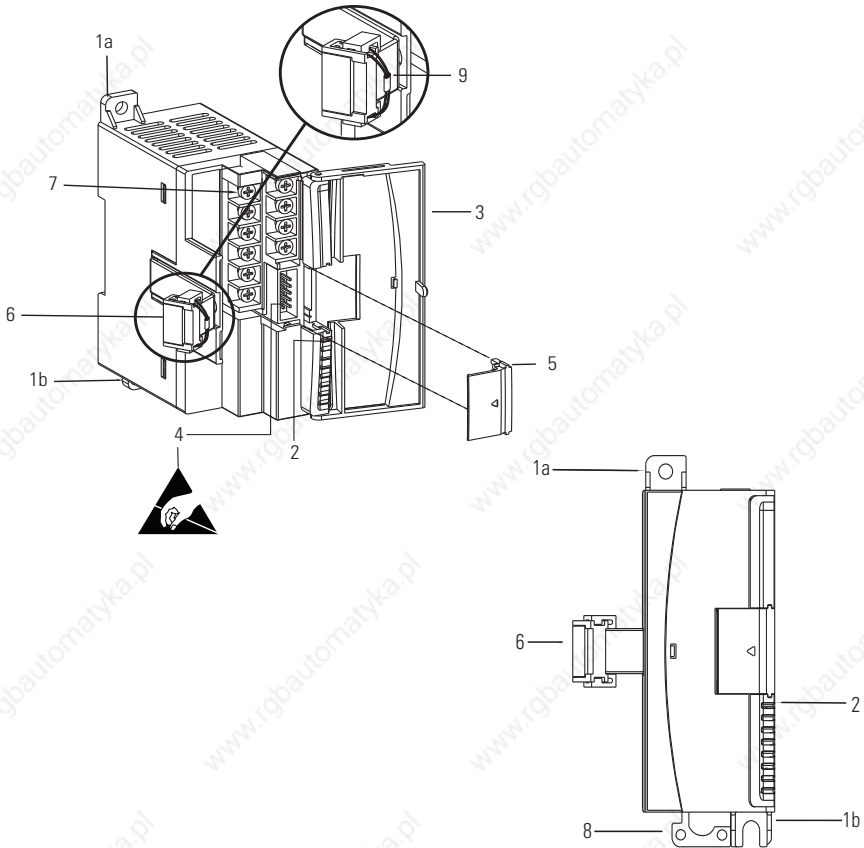

| Item | Description                                    | Item | Description  |
|------|--|------|--|
| 1a   | upper panel mounting tab                       | 5    | bus connector cover                                |
| 1b   | lower panel mounting tab                       | 6    | flat ribbon cable with bus connector (female pins) |
| 2    | I/O diagnostic LEDs                            | 7    | terminal block                                     |
| 3    | module door with terminal identification label | 8    | DIN rail latch                                     |
| 4    | bus connector with male pins                   | 9    | pull loop  |

## Installation

1762 I/O is suitable for use in an industrial environment when installed in accordance with these instructions. Specifically, this equipment is intended for use in clean, dry environments (Pollution degree 2<sup>(1)</sup>) and to circuits not exceeding Over Voltage Category II<sup>(2)</sup> (IEC 60664-1).<sup>(3)</sup>

## Prevent Electrostatic Discharge

---

### ATTENTION



Electrostatic discharge can damage integrated circuits or semiconductors if you touch bus connector pins. Follow these guidelines when you handle the module:

- Touch a grounded object to discharge static potential.
  - Wear an approved wrist-strap grounding device.
  - Do not touch the bus connector or connector pins.
  - Do not touch circuit components inside the module.
  - If available, use a static-safe work station.
  - When not in use, keep the module in its static-shield box.
- 

## Remove Power

---

### ATTENTION



Remove power before removing or installing this module. When you remove or install a module with power applied, an electrical arc may occur. An electrical arc can cause personal injury or property damage by:

- sending an erroneous signal to your system's field devices, causing unintended machine motion
- causing an explosion in a hazardous environment
- causing permanent damage to the module's circuitry

Electrical arcing causes excessive wear to contacts on both the module and its mating connector. Worn contacts may create electrical resistance.

---

(1) Pollution Degree 2 is an environment where, normally, only non-conductive pollution occurs except that occasionally a temporary conductivity caused by condensation shall be expected.

(2) Over Voltage Category II is the load level section of the electrical distribution system. At this level transient voltages are controlled and do not exceed the impulse voltage capability of the product's insulation.

(3) Pollution Degree 2 and Over Voltage Category II are International Electrotechnical Commission (IEC) designations.

## Mounting

### ATTENTION



Do not remove protective debris strip until after the module and all other equipment near the module is mounted and wiring is complete. Once wiring is complete and the module is free of debris, carefully remove protective debris strip. Failure to remove strip before operating can cause overheating.

## Minimum Spacing

Maintain spacing from enclosure walls, wireways, adjacent equipment, etc. Allow 50.8 mm (2 in.) of space on all sides for adequate ventilation, as shown:

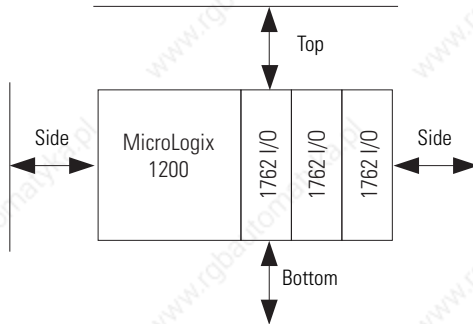

### TIP

1762 expansion I/O may be mounted horizontally only.

### ATTENTION



During panel or DIN rail mounting of all devices, be sure that all debris (metal chips, wire strands, etc.) is kept from falling into the module. Debris that falls into the module could cause damage when power is applied to the module.

## DIN Rail Mounting

The module can be mounted using the following DIN rails: 35 x 7.5 mm (EN 50 022 - 35 x 7.5) or 35 x 15 mm (EN 50 022 - 35 x 15).

Before mounting the module on a DIN rail, close the DIN rail latch. Press the DIN rail mounting area of the module against the DIN rail. The latch will momentarily open and lock into place.

Use DIN rail end anchors (Allen-Bradley part number 1492-EA35 or 1492-EAH35) for vibration or shock environments.

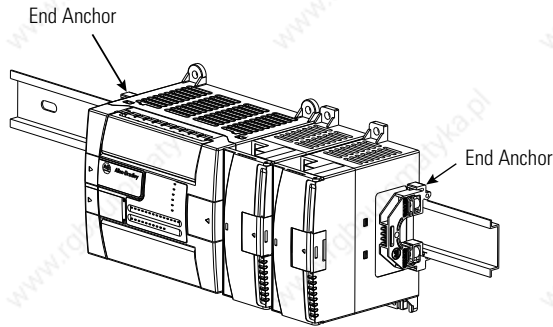

**TIP**

For environments with greater vibration and shock concerns, use the panel mounting method described below, instead of DIN rail mounting.

## Panel Mounting

Use the dimensional template shown below to mount the module. The preferred mounting method is to use two M4 or #8 panhead screws per module. M3.5 or #6 panhead screws may also be used, but a washer may be needed to ensure a good mechanical contact. Mounting screws are required on every module.

For more than two modules: (number of modules - 1) x 40.4 mm (1.59 in.)

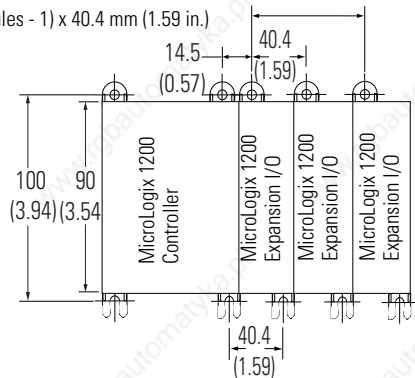

NOTE: All dimensions are in mm (inches).  
Hole spacing tolerance: ±0.4 mm (0.016 in.).

## System Assembly

The expansion I/O module is attached to the controller or another I/O module by means of a flat ribbon cable after mounting as shown below.

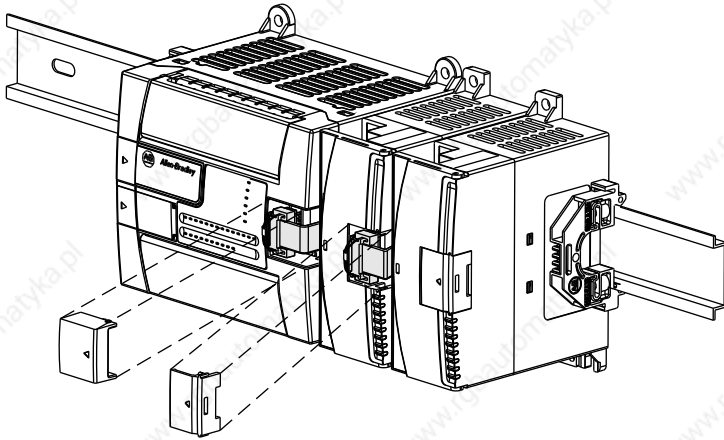
**TIP**

Use the pull loop on the connector to disconnect modules. Do not pull on the ribbon cable.

**ATTENTION****EXPLOSION HAZARD**

- In Class I, Division 2 applications, the bus connector must be fully seated and the bus connector cover must be snapped in place.
- In Class I, Division 2 applications, all modules must be mounted in direct contact with each other as shown on Page 6. If DIN rail mounting is used, an end stop must be installed ahead of the controller and after the last 1762 I/O module.

# Field Wiring Connections

## Grounding the Module

This product is intended to be mounted to a well-grounded mounting surface such as a metal panel. Refer to Industrial Automation Wiring and Grounding Guidelines, Allen-Bradley publication 1770-4.1, for additional information.

## Output Wiring

Basic wiring of the 1762-OB8 is shown below.

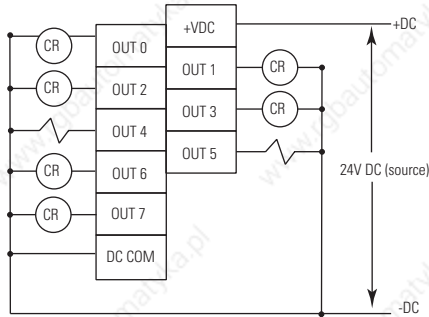

A write-on label is provided with the module. Mark the identification of each terminal with permanent ink, and slide the label back into the door.

### ATTENTION

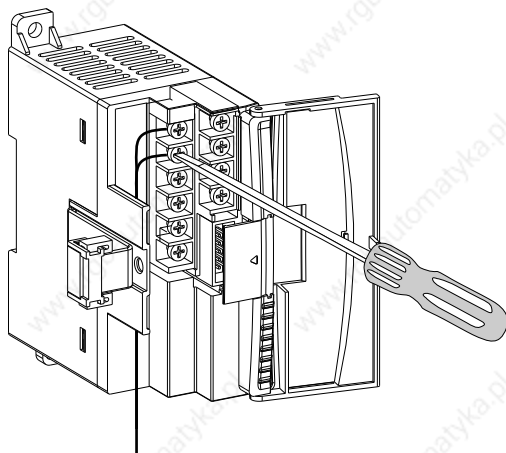

Be careful when stripping wires. Wire fragments that fall into a module could cause damage when power is applied. Once wiring is complete, ensure the module is free of all metal fragments.

**TIP**

Finger-safe cover not shown for clarity.

## Wiring the Finger-Safe Terminal Block

When wiring the terminal block, keep the finger-safe cover in place.

1. Route the wire under the terminal pressure plate. You can use the stripped end of the wire or a spade lug. The terminals will accept a 6.35 mm (0.25 in.) spade lug.
2. Tighten the terminal screw making sure the pressure plate secures the wire. Recommended torque when tightening terminal screws is 0.90 Nm (8 lb-in.).

**TIP**

If you need to remove the finger-safe cover, insert a screw driver into one of the square wiring holes and gently pry the cover off. If you wire the terminal block with the finger-safe cover removed, you will not be able to put it back on the terminal block because the wires will be in the way.

## Wire Size and Terminal Screw Torque

Each terminal accepts up to two wires with the following restrictions:

| Wire Type |                   | Wire Size     | Terminal Screw Torque |
|-----------|-------------------|---------------|-----------------------|
| Solid     | Cu-90 °C (194 °F) | #14 ...22 AWG | 0.904 Nm (8 lb-in.)   |
| Stranded  | Cu-90 °C (194 °F) | #16...22 AWG  | 0.904 Nm (8 lb-in.)   |

# I/O Memory Mapping

## Output Data File

For each output module, the output data file contains the controller-directed state of the discrete output points. Bit positions 0...7 correspond to output terminals 0...7.

| Word | Bit Position |    |    |    |    |    |   |   |   |   |   |   |   |   |   |   |
|------|--------------|----|----|----|----|----|---|---|---|---|---|---|---|---|---|---|
|      | 15           | 14 | 13 | 12 | 11 | 10 | 9 | 8 | 7 | 6 | 5 | 4 | 3 | 2 | 1 | 0 |
| 0    | 0            | 0  | 0  | 0  | 0  | 0  | 0 | 0 | w | w | w | w | w | w | w | w |

w = write only, 0 = always at a 0 or OFF state

## Addressing

The addressing scheme for 1762 Expansion I/O is shown below.

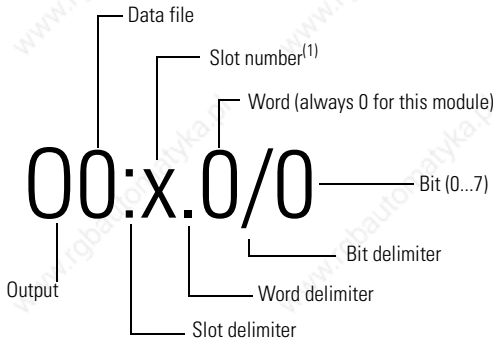

(1) I/O located on the controller (embedded I/O) is slot 0. I/O added to the controller (expansion I/O) begins with slot 1.

# Specifications

## General Specifications

| Specification                             | Value   |
|---|---|
| Dimensions, HxWxD                         | 90 x 40.4 x 87 mm (height including mounting tabs is 110 mm)<br>3.54 x 1.59 x 3.43 in. (height including mounting tabs is 4.33 in.) |
| Approximate Shipping Weight (with carton) | 210 g (0.46 lbs.)   |
| Storage Temperature                       | -40...85 °C (-40...185 °F)  |
| Operating Temperature                     | 0...55 °C (32...131 °F)   |
| Operating Humidity                        | 5...95% non-condensing  |
| Operating Altitude                        | 2000 m (6561 ft)  |
| Vibration                                 | Refer to the MicroLogix 1200 Controllers Installation Instructions, publication <a href="#">1762-IN006</a> .                        |
| Shock                                     |   |
| Hazardous Environment Class               | Class I, Division 2, Hazardous Location, Groups A, B, C, D<br>ISA/ANSI12.12.01<br>(C-UL under CSA C22.2 No. 213)                    |
| Noise Immunity                            | NEMA standard ICS 2-230   |
| Radiated and Conducted Emissions          | EN50081-2 Class A   |
| ESD Immunity (IEC1000-4-2)                | 4 kV contact, 8 kV air, 4 kV indirect   |
| Radiated Immunity (IEC1000-4-3)           | 10 V/m, 80...1000 MHz, 80% amplitude modulation, +900 MHz keyed carrier   |
| Fast Transient Burst (IEC1000-4-4)        | 2 kV, 5 kHz   |
| Surge Immunity (IEC1000-4-5)              | 2 kV common mode, 1 kV differential mode  |
| Conducted Immunity (IEC1000-4-6)          | 10V, 0.15...80 MHz <sup>(1)</sup>   |

(1) Conducted Immunity frequency range may be 150 kHz...30 MHz if the Radiated Immunity frequency range is 30...1000 MHz.

## Output Specifications

| Specification                        | 1762-0B8  |
|--------------------------------------|---|
| Voltage Category                     | 24V DC  |
| Operating Voltage Range              | 20.4...26.4V DC   |
| Number of Outputs                    | 8   |
| Bus Current Draw (max.)              | 115 mA @ 5V DC (0.575W)   |
| Heat Dissipation (max.)              | 1.61 Total Watts  |
| Signal Delay (max.) – resistive load | On Delay: 0.1 ms<br>Off Delay: 1.0ms  |
| Off-State Leakage (max.)             | 1.0 mA  |
| On-State Current (min.)              | 1.0 mA  |
| On-State Voltage Drop (max.)         | 1.0V DC   |
| Continuous Current per Point (max.)  | 0.5A @ 55°C; 1.0A @ 30°C  |
| Continuous Current per Module (max.) | 4.0 A @ 55°C; 8.0 A @ 30°C  |
| Surge Current (maximum)              | 2.0 A (Repeatability is once every 2 seconds for a duration of 10 msec.)  |
| Power Supply Distance Rating         | 6 (The module may not be more than 6 modules away from the power supply.)   |
| Isolated Groups                      | Group 1: Outputs 0...7  |
| Output Group to Backplane Isolation  | Verified by one of the following dielectric tests: 1200V AC for 1 sec. or 1697V DC for 1 sec.<br>75V DC working voltage (IEC Class 2 reinforced insulation) |
| Vendor ID Code                       | 1   |
| Product Type Code                    | 7   |
| Product Code                         | 101   |

**Sourcing Output** - Source describes the current flow between the I/O module and the field device. Sourcing output circuits supply (source) current to sinking field devices. Field devices connected to the negative side (DC Common) of the field power supply are sinking field devices. Field devices connected to the positive side (+V) of the field supply are sourcing field devices. Europe: DC sinking input and sourcing output module circuits are the commonly used options.

**Typical Loading Resistor** - To limit the effects of leakage current through solid-state outputs, a loading resistor can be connected in parallel with your load. Use a 5.6k  $\Omega$  1/4W resistor for transistor outputs, 24V DC operation.

**Recommended Surge Suppression** - Use a 1N4004 diode reverse-wired across the load for transistor outputs switching 24V DC inductive loads. For additional information, refer to Industrial Automation Wiring and Grounding Guidelines, Allen-Bradley publication 1770-4.1.



## Certifications

| Certification (when product is marked) <sup>(1)</sup> | Value  |
|---|--|
| c-UL-us   | UL Listed Industrial Control Equipment, certified for US and Canada.<br><br>UL Listed for Class I, Division 2 Group A,B,C,D Hazardous Locations, certified for U.S. and Canada. See UL File E334470.   |
| CE  | European Union 2004/108/EC EMC Directive, compliant with:<br>EN 61326-1; Meas./Control/Lab., Industrial Requirements<br>EN 61000-6-2; Industrial Immunity<br>EN 61000-6-4; Industrial Emissions<br>EN 61131-2; Programmable Controllers (Clause 8, Zone A & B) |
| C-Tick  | Australian Radiocommunications Act, compliant with:<br>AS/NZS CISPR 11; Industrial Emissions   |
| KC  | Korean Registration of Broadcasting and Communications Equipment, compliant with:<br>Article 58-2 of Radio Waves Act, Clause 3   |

(1) See the Product Certification link at <http://www.rockwellautomation.com/products/certification> for Declaration of Conformity, Certificates, and other certification details.

## North American Hazardous Location Approval

The following modules are North American Hazardous Location approved: 1762-OB8

|  |  |   |   |
|--|--|---|---|
| <p><b>The following information applies when operating this equipment in hazardous locations:</b></p>  | <p><b>Informations sur l'utilisation de cet équipement en environnements dangereux:</b></p>  |   |   |
| <p>Products marked "CL I, DIV 2, GP A, B, C, D" are suitable for use in Class I Division 2 Groups A, B, C, D, Hazardous Locations and nonhazardous locations only. Each product is supplied with markings on the rating nameplate indicating the hazardous location temperature code. When combining products within a system, the most adverse temperature code (lowest "T" number) may be used to help determine the overall temperature code of the system. Combinations of equipment in your system are subject to investigation by the local Authority Having Jurisdiction at the time of installation.</p> | <p>Les produits marqués "CL I, DIV 2, GP A, B, C, D" ne conviennent qu'à une utilisation en environnements de Classe I Division 2 Groupes A, B, C, D dangereux et non dangereux. Chaque produit est livré avec des marquages sur sa plaque d'identification qui indiquent le code de température pour les environnements dangereux. Lorsque plusieurs produits sont combinés dans un système, le code de température le plus défavorable (code de température le plus faible) peut être utilisé pour déterminer le code de température global du système. Les combinaisons d'équipements dans le système sont sujettes à inspection par les autorités locales qualifiées au moment de l'installation.</p>  |   |   |
| <p><b>WARNING</b></p>   | <p><b>EXPLOSION HAZARD</b></p> <ul style="list-style-type: none"> <li>Do not disconnect equipment unless power has been removed or the area is known to be nonhazardous.</li> <li>Do not disconnect connections to this equipment unless power has been removed or the area is known to be nonhazardous. Secure any external connections that mate to this equipment by using screws, sliding latches, threaded connectors, or other means provided with this product.</li> <li>Substitution of any component may impair suitability for Class I, Division 2.</li> <li>If this product contains batteries, they must only be changed in an area known to be nonhazardous.</li> <li>All wiring must comply with N.E.C. article 501-4(b).</li> <li>The interior of the enclosure must be accessible only by the use of a tool.</li> <li>For applicable equipment (relay modules, etc.), exposure to some chemicals may degrade the sealing properties of materials used in the following devices: Relays, Epoxy. It is recommended that the User periodically inspect these devices for any degradation of properties and replace the module if degradation is found.</li> </ul> | <p><b>AVERTISSEMENT</b></p>  | <p><b>RISQUE D'EXPLOSION</b></p> <ul style="list-style-type: none"> <li>Couper le courant ou s'assurer que l'environnement est classé non dangereux avant de débrancher l'équipement.</li> <li>Couper le courant ou s'assurer que l'environnement est classé non dangereux avant de débrancher les connecteurs. Fixer tous les connecteurs externes reliés à cet équipement à l'aide de vis, loquets coulissants, connecteurs filetés ou autres moyens fournis avec ce produit.</li> <li>La substitution de tout composant peut rendre cet équipement inadapté à une utilisation en environnement de Classe I, Division 2.</li> <li>S'assurer que l'environnement est classé non dangereux avant de changer les piles.</li> </ul> |

---

## Notes:

## Rockwell Automation Support

Rockwell Automation provides technical information on the Web to assist you in using its products. At <http://www.rockwellautomation.com/support/>, you can find technical manuals, a knowledge base of FAQs, technical and application notes, sample code and links to software service packs, and a MySupport feature that you can customize to make the best use of these tools.

For an additional level of technical phone support for installation, configuration and troubleshooting, we offer TechConnect support programs. For more information, contact your local distributor or Rockwell Automation representative, or visit <http://www.rockwellautomation.com/support/>.

## Installation Assistance

If you experience a problem within the first 24 hours of installation, please review the information that's contained in this manual. You can also contact a special Customer Support number for initial help in getting your product up and running.

|                                 |  |
|---------------------------------|--|
| United States or Canada         | 1.440.646.3434   |
| Outside United States or Canada | Use the <a href="#">Worldwide Locator</a> at <a href="http://www.rockwellautomation.com/support/americas/phone_en.html">http://www.rockwellautomation.com/support/americas/phone_en.html</a> , or contact your local Rockwell Automation representative. |

## New Product Satisfaction Return

Rockwell Automation tests all of its products to ensure that they are fully operational when shipped from the manufacturing facility. However, if your product is not functioning and needs to be returned, follow these procedures.

|                       |   |
|-----------------------|---|
| United States         | Contact your distributor. You must provide a Customer Support case number (call the phone number above to obtain one) to your distributor to complete the return process. |
| Outside United States | Please contact your local Rockwell Automation representative for the return procedure.  |

## Documentation Feedback

Your comments will help us serve your documentation needs better. If you have any suggestions on how to improve this document, complete this form, publication [RA-DU002](#), available at <http://www.rockwellautomation.com/literature/>.

Allen-Bradley, Rockwell Automation, MicroLogix, and TechConnect are trademarks of Rockwell Automation, Inc.

Trademarks not belonging to Rockwell Automation are property of their respective companies.

Rockwell Otomasyon Ticaret A.Ş., Kar Plaza İş Merkezi E Blok Kat:6 34752 İçerenköy, İstanbul, Tel: +90 (216) 5698400  
**[www.rockwellautomation.com](http://www.rockwellautomation.com)**

### Power, Control and Information Solutions Headquarters

Americas: Rockwell Automation, 1201 South Second Street, Milwaukee, WI 53204-2496 USA, Tel: (1) 414.382.2000, Fax: (1) 414.382.4444

Europe/Middle East/Africa: Rockwell Automation, Vorstlaan/Boulevard du Souverain 36, 1170 Brussels, Belgium, Tel: (32) 2 663 0600, Fax: (32) 2 663 0640

Publication 1762-IN008B-EN-P - July 2013

Supersedes Publication 1762-IN008A-EN-P - July 2000

Copyright © 2013 Rockwell Automation, Inc. All rights reserved.