

**RE 29 751/02.03**

Ersetzt: 07.02

**Electrical amplifier module for  
controlling proportional pressure relief  
valves with electrical position feedback  
Type VT 11025**

Series 1X



H/A 5292 / 95

Type VT 11025

**Table of contents**

Contents	Page
Features	1
Ordering code, preferred types	1
Function	2
Technical data	2
Characteristics in the event of a fault	3
Block circuit diagram	3
Engineering / maintenance notes / supplementary information	4
Unit dimensions	4

**Features**

VT 11 025 amplifiers are used for controlling direct operated proportional pressure relief valves with electrical position feedback (type DBETR).

- Differential input
- Adjustable ramp generator (max. ramp time 5 s)
- Clocked output stage
- Controller for valve spool position
- Reverse polarity protection for voltage supply
- Oscillator and demodulator for inductive position measurement
- Controller enable
- LED lamps: "power" – internal supply voltage (green) "H1"
- Multifunctional indicator (orange)

**Ordering code****VT 11 025 -1X/ \***

Amplifier module  
for proportional pressure relief valves type DBETR

Further details in clear text

**1X =**

Series 15 to 19 <sup>1)</sup>  
(15 to 19: unchanged technical data  
and pin assignment)

**Preferred types**

Material no.	Type
R900019666	VT11025-1X

<sup>1)</sup> Compatible with components of series 10 to 14, if terminal 6 of these components was not connected to ground (0 V) (see engineering notes on page 4).



© 2003

by Bosch Rexroth AG, Industrial Hydraulics, D-97813 Lohr am Main

All rights reserved. No part of this document may be reproduced or stored, processed, duplicated or circulated using electronic systems, in any form or by means, without the prior written authorisation of Bosch Rexroth AG. In the event of contravention of the above provisions, the contravening party is obliged to pay compensation.

## Function

This amplifier module is to be snapped onto carrier rails that are usually installed in control cabinets. The electrical connection is made via a terminal strip.

The amplifier module includes the electronics for controlling a proportional solenoid. The amplifier module controls the solenoid in dependence upon a positive voltage signal applied to the command value input. The actual value (position of the magnet armature) is sensed by an inductive position measuring system and compared with the command value that is provided externally. Any differences between the actual and the command value are corrected. The controller and the output stage are enabled by applying a positive voltage ( $U_f > 8.5 \text{ V}$ ) to terminal 3.

The following parameters can be adjusted from outside using a trimming potentiometer each:

- Ramp time up to approx. 5 s
- Command value attenuation within the range from 0 % to 100 %
- Zero point of the position transducer

## Technical data (for applications outside these parameters, please consult us!)

Operating voltage	$U_O$	+ 24 VDC + 40 % – 10 %
Operating range:		
– Upper limit value	$u_O(t)_{\max}$	+ 39 V
– Lower limit value	$u_O(t)_{\min}$	+ 21 V
Max. current consumption	$I$	2 A
Fuse	$I$	3 A; slow-blowing; self-activating after tripping
Inputs:		
– Differential input (command value input)	$U_i$	0 to + 10 V; $R_i = 50 \text{ k}\Omega$ (standard) <sup>1)</sup>
– Enable		
• active	$U_E$	$8.5 \text{ V} < U_E < 40 \text{ V}$
• inactive	$U_E$	$< 6.5 \text{ V}$
– Demodulator input (position measuring system)	$R_i$	$> 50 \text{ k}\Omega$
Ramp time (adjustment range)	$t$	10 ms to 5 s
Outputs:		
– Output stage		
• solenoid current/resistance	$I_{\max}$	1.8 A; $R_{(20)} = 10 \Omega$
• clock-pulse frequency	$f$	Freely clock-pulsing up to approx. 1.5 kHz
– Driver for inductive position transducer		
• oscillator frequency	$f$	5.8 kHz $\pm$ 10 %
• max. load-carrying capacity	$I$	30 mA
• voltage amplitude ( $U_{SS}$ )	$U_a$	5 V per output
• max. stroke of position transducer	$s$	3.8 mm
– Measuring sockets		
• command value $w$	$U_w$	0 to + 5 V
• actual position value $x$	$U_x$	0 to – 5 V
Type of connection		12-pin terminal strip
Housing dimensions (W x H x D)		40 x 79 x 85.5 mm
Permissible operating temperature range	$t$	0 to 50 °C in accordance with DIN IEC 68-2 T1, T2, T14 and T30 <sup>2)</sup>
Storage temperature range	$t$	– 25 to + 85 °C in accordance with DIN IEC 68-2 T1 and T2 <sup>2)</sup>
Immunity to interference		Class 3 to prEN 50082 T2 <sup>2)</sup>
Mechanical stress		To DIN IEC 68-2 T6, T24 and T27 <sup>2)</sup>
Weight	$m$	0.14 kg

1) Current input on enquiry

2) Further details on enquiry

## Characteristics in the event of a fault

Fault	Missing enable ( $U_E < 6.5\text{ V}$ )	Cable break of position transducer	Cable break of current input <sup>1)</sup>
Behaviour of electronics	<b>E, R, A</b>	<b>E, R, A</b>	<b>S, A</b>

<sup>1)</sup> Only with special version with current input 4 to 20 mA (on enquiry)

Meaning of abbreviations:

- E** = Output stage is switched off (solenoids are de-energized!)
- R** = Controller is switched off
- S** = Command value is set to 0 %
- A** = Multifunction indicator is alight

## Block circuit diagram / pin assignment VT 11025 (from series 15)

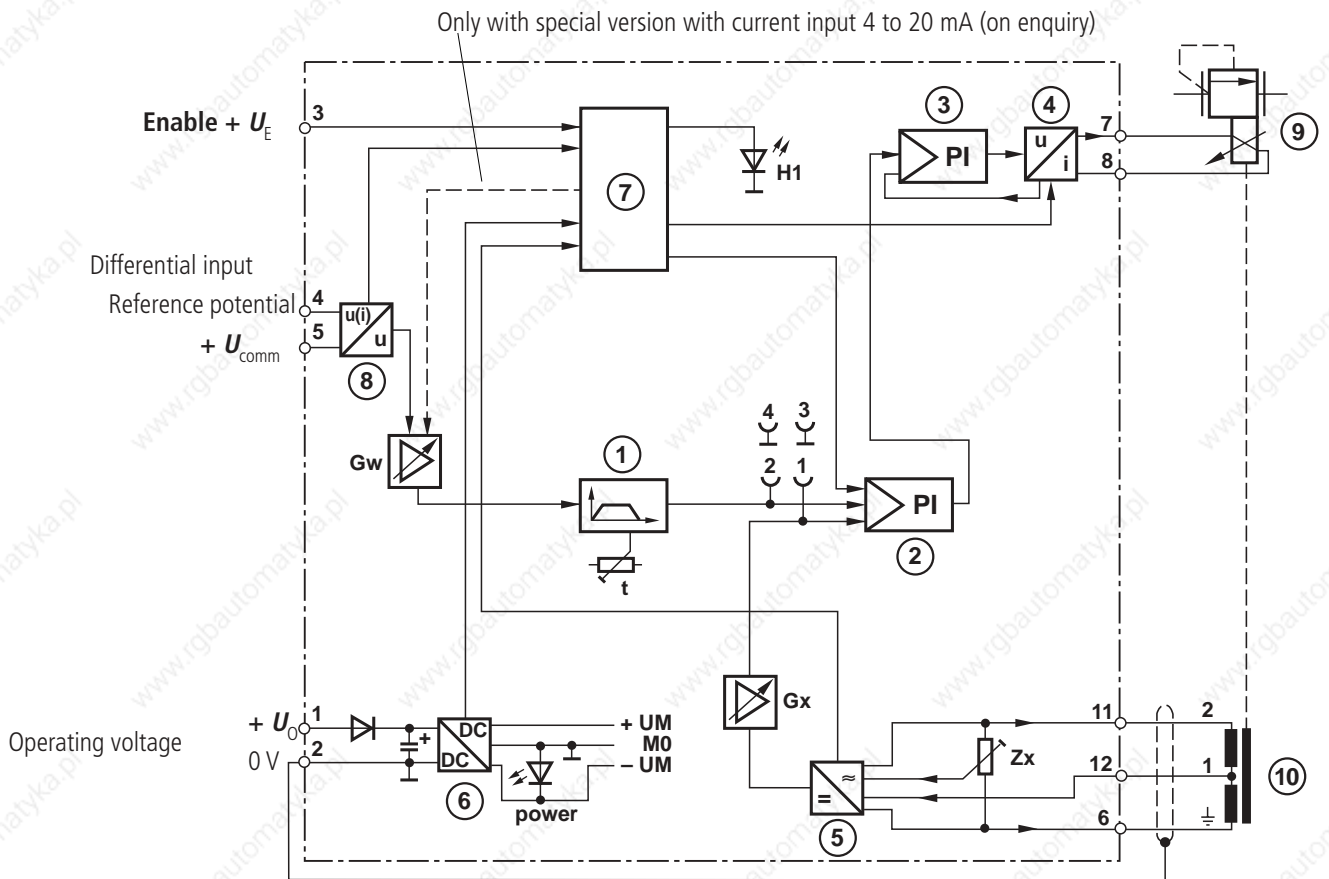

- |                                    |                               |                                 |                                      |
|------------------------------------|-------------------------------|---------------------------------|--------------------------------------|
| <b>1</b> Ramp generator            | <b>6</b> Power supply unit    | <b>↓</b> Actual value 0 to -5 V | <b>H1</b> Multifunction indicator    |
| <b>2</b> Spool position controller | <b>7</b> Monitoring           | <b>↕</b> Comm. value 0 to +5 V  | <b>Zx</b> Pos. transducer zero point |
| <b>3</b> Current regulator         | <b>8</b> Differential amp.    | <b>3</b> Measuring zero         | <b>Gw</b> Comm. value attenuation    |
| <b>4</b> Output stage              | <b>9</b> Proportional valve   | <b>↓</b> Measuring zero         | <b>Gx</b> Actual value adjustment    |
| <b>5</b> Oscillator/demodulator    | <b>10</b> Position transducer |                                 | <b>t</b> Ramp time                   |

### Connecting cable (recommendation):

- Position transducer 3-wire cable, simple shield, cross-section max. 1.5 mm<sup>2</sup>
- Solenoid connection 2- or 4-wire cable, simple shield, cross-section max. 1.5 mm<sup>2</sup>
- Differential input 2-wire cable, simple shield

