

7 BSF..

7.1 BSF.., BSBF.., BSKF.., BSHF..

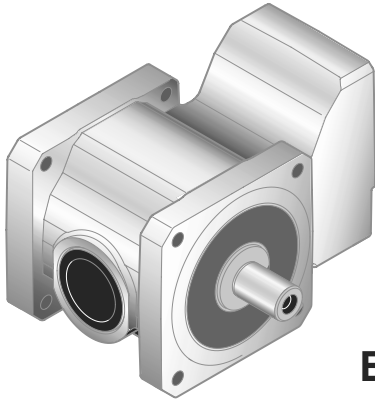

BSF..

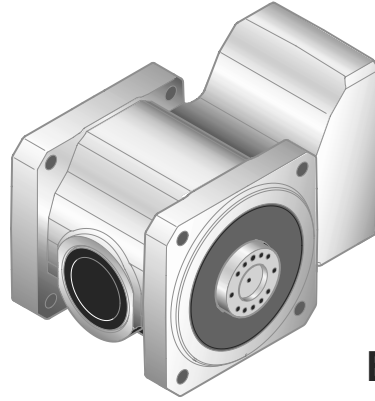

BSBF..

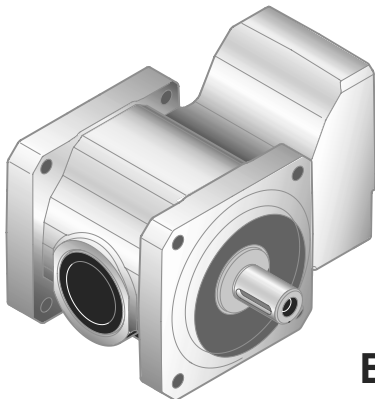

BSKF..

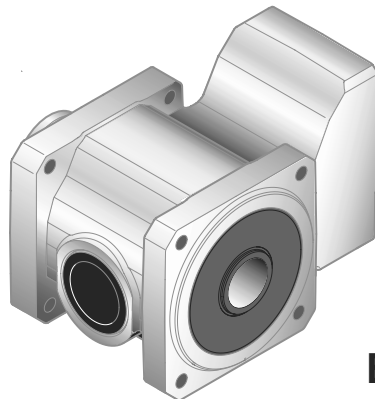

BSHF..

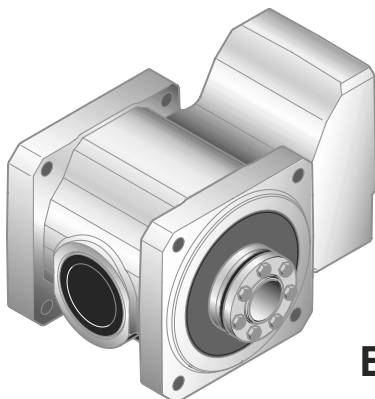

BSHF../I

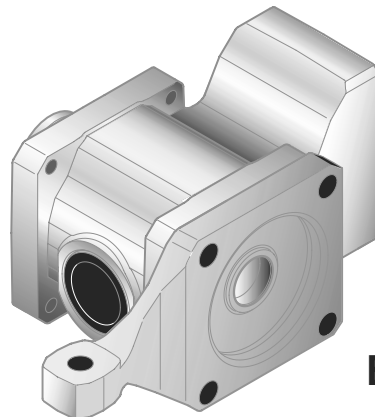

BSHF../T

53315AXX

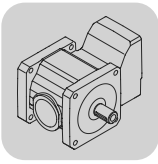

BSF..
BSF.., BSBF.., BSKF.., BSHF..

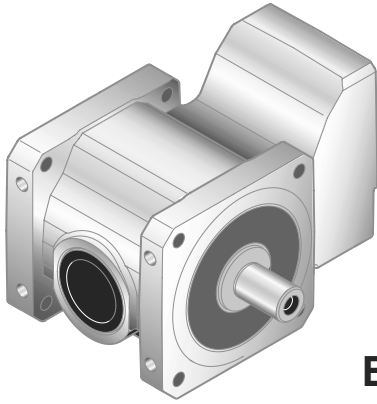

BSF..B

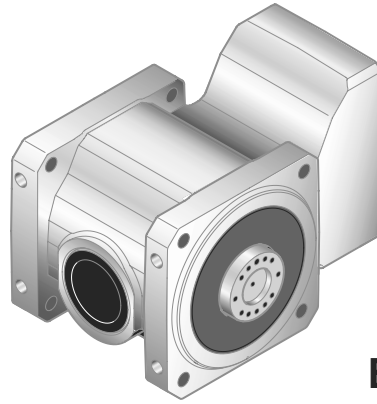

BSBF..B

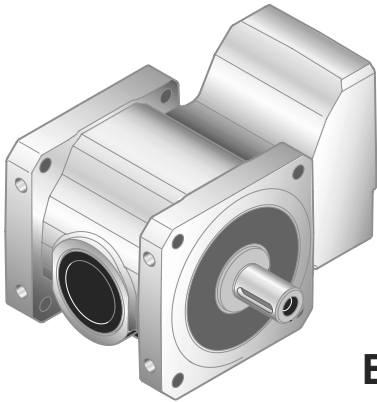

BSKF..B

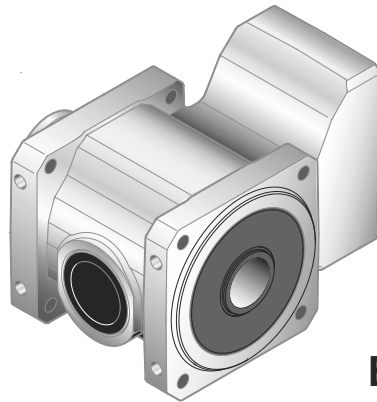

BSHF..B

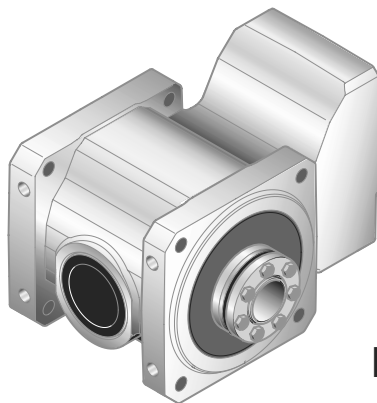

BSHF..B / I

53316AXX

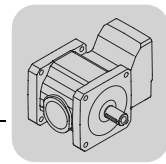

7.2 BSF.. DS../CM.. [Nm]

M ₀ [Nm]	n _a [1/min]	M _a [Nm]	i	F _{Ra} ¹⁾ [N]	SEW f _B	M _{DYN} [Nm]	M _a ^{DYN} [Nm]	F _{Ra} ^{DYN} [N]	SEW f _B ^{DYN}			m [kg]				
1.0	50	26	30.00*	5480	3.0	3.5	96	4990	1.15		BSF 302 DS 56M	8.4	117			
	60	22	25.00*	5490	3.7		80	5160	1.40		BSBF 302 DS 56M	8.7	118			
	75	17	20.00*	5500	4.7		63	5290	1.75		BSHF 302 DS 56M	8.3	119			
	60	22	25.00*	4200	1.80		51	4200	1.00	X						
	75	17	20.00*	4200	2.3		51	4200	1.00	X		BSF 202 DS 56M	6.4	113		
	100	13	15.00*	4200	3.1		48	4200	1.05			BSBF 202 DS 56M	6.4	114		
	150	8.1	10.00*	4200	4.9		31	4200	1.65			BSHF 202 DS 56M	6.4	115		
	188	7.1	8.00*	4200	5.6		26	4080	2.3							
2.0	50	54	30.00*	5360	1.45	7.0	112	4780	1.00	X	BSF 302 DS 56L	9.4	117			
	60	45	25.00*	5410	1.80		112	4780	1.00	X						
	75	36	20.00*	5450	2.3		112	4780	1.00	X						
	100	26	15.00*	5480	3.1		96	4990	1.15							
	150	17	10.00*	5500	4.3		63	5300	1.70		BSBF 302 DS 56L	9.7	118			
	188	15	8.00*	5510	5.5		53	5370	2.3							
	60	45	25.00*	4200	0.90		51	4200	1.00	X				BSF 202 DS 56L	7.4	113
	75	36	20.00*	4200	1.10		51	4200	1.00	X						
	100	27	15.00*	4200	1.50		51	4200	1.00	X						
	150	17	10.00*	4200	2.3		51	3990	1.00	X						
	188	15	8.00*	4200	2.7		53	3770	1.15		BSBF 202 DS 56L	7.4	114			
	250	11	6.00*	3860	3.7		39	3520	1.50							
	375	7.1	4.00*	3400	5.6		26	3180	2.3							
	60	45	25.00*	5040	0.90		112	4780	1.00	X				BSF 302 DS 56H	10	117
	75	36	20.00*	5220	1.10		112	4780	1.00	X						
	100	27	15.00*	5360	1.50		112	4780	1.00	X						
150	17	10.00*	5450	2.0	108	4840	1.00	X								
188	15	8.00*	5470	2.7	106	4870	1.15		BSBF 302 DS 56H	10	118					
250	11	6.00*	5490	3.6	79	5170	1.50									
375	7.1	4.00*	5490	5.2	52	5170	2.2									
150	36	10.00*	4200	1.10	51	3990	1.00	X				BSF 202 DS 56H	8.1	113		
188	30	8.00*	4030	1.35	60	3680	1.00	X								
250	22	6.00*	3720	1.80	60	3280	1.00	X								
375	15	4.00*	3310	2.7	53	2860	1.15									
500	11	3.00*	3040	3.7	39	2700	1.55		BSBF 202 DS 56H	8.1	115					
50	108	30.00*	9310	1.50	14	225	8840	1.00				X	BSF 402 DS 56H	15	121	
60	90	25.00*	9350	1.80		225	8840	1.00				X				
75	71	20.00*	9390	2.2		220	8870	1.00				X				
100	52	15.00*	9420	2.7		191	9010	1.10								
150	33	10.00*	9430	3.7		126	9260	1.45		BSBF 402 DS 56H	15	122				
188	29	8.00*	9440	5.5		105	9320	2.0								
60	91	25.00*	5040	0.90		112	4780	1.00	X				BSF 302 DS 56H	10	117	
75	73	20.00*	5220	1.10		112	4780	1.00	X							
100	54	15.00*	5360	1.50		112	4780	1.00	X							
150	35	10.00*	5450	2.0		108	4840	1.00	X							
188	30	8.00*	5470	2.7		106	4870	1.15		BSBF 302 DS 56H	10	118				
250	22	6.00*	5490	3.6		79	5170	1.50								
375	15	4.00*	5490	5.2		52	5170	2.2								
150	36	10.00*	4200	1.10		51	3990	1.00	X				BSF 202 DS 56H	8.1	113	
188	30	8.00*	4030	1.35		60	3680	1.00	X							
250	22	6.00*	3720	1.80		60	3280	1.00	X							
375	15	4.00*	3310	2.7	53	2860	1.15									
500	11	3.00*	3040	3.7	39	2700	1.55		BSBF 202 DS 56H	8.1	115					
5.0	38	175	40.00*	24000	3.0	18	640	24000				1.15		BSF 602 CM 71S	55	129
	43	151	35.00*	24000	3.4		560	24000				1.35				
	50	128	30.00*	24000	4.1		475	24000				1.60				
	60	105	25.00*	24000	5.0		395	24000	1.90							
	50	133	30.00*	12500	1.90		375	12000	1.00	X	BSF 502 CM 71S	38	125			
	60	110	25.00*	12600	2.3		375	12000	1.00	X						
	75	86	20.00*	12600	2.9		320	12200	1.20							
	100	63	15.00*	12600	4.0		235	12400	1.60							
125	54	12.00*	12600	5.5	197	12400	2.1		BSBF 502 CM 71S	37	127					
60	113	25.00*	9300	1.40	225	8840	1.00	X				BSF 402 CM 71S	20	121		
75	89	20.00*	9350	1.70	220	8870	1.00	X								
100	66	15.00*	9400	2.1	210	8920	1.00	X								
150	43	10.00*	9430	2.9	159	9150	1.15									
188	37	8.00*	9430	4.4	131	9240	1.60		BSBF 402 CM 71S	20	123					
75	91	20.00*	5040	0.90	112	4780	1.00	X				BSF 302 CM 71S	16	117		
100	68	15.00*	5260	1.20	112	4780	1.00	X								
150	45	10.00*	5410	1.60	108	4840	1.00	X								
188	37	8.00*	5440	2.1	120	4660	1.00	X								
250	28	6.00*	5480	2.9	99	4950	1.20		BSBF 302 CM 71S	16	118					
375	18	4.00*	5460	4.2	66	5060	1.75									
500	14	3.00*	4990	5.0	49	4680	2.1									
												BSHF 302 CM 71S	16	119		

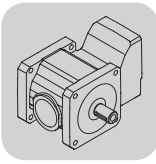
BSF..
BSF.. DS../CM.. [Nm]

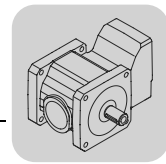

M_0 [Nm]	n_a [1/min]	M_a [Nm]	i	$F_{Ra}^{1)}$ [N]	SEW f_B	M_{DYN} [Nm]	M_a^{DYN} [Nm]	F_{Ra}^{DYN} [N]	SEW f_B^{DYN}			m [kg]	
6.5	38	230	40.00*	24000	2.3	23	750	24000	1.00	X	 BSF 602 CM 71M BSBF 602 CM 71M BSHF 602 CM 71M	56	129
	43	200	35.00*	24000	2.6		730	24000	1.05			56	130
	50	170	30.00*	24000	3.1		620	24000	1.20			53	131
	60	139	25.00*	24000	3.7		515	24000	1.45				
	75	109	20.00*	24000	4.8		410	24000	1.85				
	50	175	30.00*	12500	1.45		375	12000	1.00	X	 BSF 502 CM 71M BSBF 502 CM 71M BSHF 502 CM 71M	39	125
	60	145	25.00*	12500	1.75		375	12000	1.00	X		39	126
	75	114	20.00*	12600	2.2		375	12000	1.00	X		38	127
	100	84	15.00*	12600	3.0		310	12200	1.20				
	125	71	12.00*	12600	4.2		255	12300	1.60				
	150	54	10.00*	12600	4.6		205	12400	1.85				
	60	148	25.00*	9190	1.10		225	8840	1.00	X	 BSF 402 CM 71M BSBF 402 CM 71M BSHF 402 CM 71M	22	121
	75	117	20.00*	9290	1.30		220	8870	1.00	X		22	122
	100	87	15.00*	9360	1.60		210	8920	1.00	X		21	123
	150	57	10.00*	9410	2.2		186	9040	1.00	X			
	188	48	8.00*	9420	3.3		171	9100	1.25				
	250	36	6.00*	9130	4.4		128	8510	1.60				
	100	89	15.00*	5070	0.90		112	4780	1.00	X	 BSF 302 CM 71M BSBF 302 CM 71M BSHF 302 CM 71M	18	117
	150	59	10.00*	5330	1.25		108	4840	1.00	X		19	118
	188	49	8.00*	5390	1.65		120	4660	1.00	X		18	119
250	36	6.00*	5450	2.2	120	4660	1.00	X					
375	24	4.00*	5410	3.2	86	4890	1.35						
500	18	3.00*	4950	3.8	64	4560	1.60						
9.5	50	255	30.00*	24000	2.1	33	750	24000	1.00	X	 BSF 602 CM 71L BSBF 602 CM 71L BSHF 602 CM 71L	60	129
	60	210	25.00*	24000	2.5		750	24000	1.00	X		60	130
	75	165	20.00*	24000	3.2		605	24000	1.25			57	131
	100	121	15.00*	24000	4.3		450	24000	1.65				
	125	104	12.00*	24000	5.3		375	24000	2.1				
	60	215	25.00*	12400	1.15		375	12000	1.00	X	 BSF 502 CM 71L BSBF 502 CM 71L BSHF 502 CM 71L	43	125
	75	170	20.00*	12500	1.45		375	12000	1.00	X		43	126
	100	126	15.00*	12500	2.0		375	12000	1.00	X		42	127
	150	82	10.00*	12600	3.1		300	12200	1.25				
	188	69	8.00*	12600	4.6		250	12300	1.70				
	75	173	20.00*	9090	0.90		220	8870	1.00	X	 BSF 402 CM 71L BSBF 402 CM 71L BSHF 402 CM 71L	25	121
	100	129	15.00*	9250	1.10		210	8920	1.00	X		26	122
	150	84	10.00*	9360	1.45		186	9040	1.00	X		25	123
	188	71	8.00*	9390	2.3		210	8900	1.00	X			
	250	53	6.00*	9020	3.0		188	8110	1.10				
	375	35	4.00*	7950	3.9		125	7350	1.60				
500	26	3.00*	7270	4.8	93	6810	1.95						
11	50	295	30.00*	24000	1.75	39	750	24000	1.00	X	 BSF 602 CM 90S BSBF 602 CM 90S BSHF 602 CM 90S	65	129
	60	245	25.00*	24000	2.1		750	24000	1.00	X		66	130
	75	193	20.00*	24000	2.7		705	24000	1.05			62	131
	100	142	15.00*	24000	3.7		525	24000	1.45				
	125	121	12.00*	24000	4.6		435	24000	1.80				
	60	250	25.00*	12300	1.00		375	12000	1.00	X	 BSF 502 CM 90S BSBF 502 CM 90S BSHF 502 CM 90S	48	125
	75	198	20.00*	12400	1.25		375	12000	1.00	X		49	126
	100	147	15.00*	12500	1.70		375	12000	1.00	X		47	127
	150	96	10.00*	12600	2.6		350	12100	1.05				
	188	81	8.00*	12600	4.0		290	12300	1.45				
	250	60	6.00*	12600	5.3		215	12400	1.90				
	100	150	15.00*	9180	0.95		210	8920	1.00	X	 BSF 402 CM 90S BSBF 402 CM 90S BSHF 402 CM 90S	31	121
	150	98	10.00*	9330	1.25		186	9040	1.00	X		32	122
	188	82	8.00*	9370	1.95		210	8900	1.00	X		30	123
	250	61	6.00*	8960	2.6		205	7990	1.00	X			
	375	40	4.00*	7920	3.4		145	7210	1.40				
500	30	3.00*	7240	4.1	108	6710	1.70						
15	38	520	40.00*	36000	2.4	51	1680	36000	1.00	X	 BSF 802 CM 90M BSBF 802 CM 90M BSHF 802 CM 90M	96	133
	43	450	35.00*	36000	2.7		1630	36000	1.05			97	134
	50	385	30.00*	36000	3.2		1390	36000	1.20			92	135
	60	315	25.00*	36000	3.9		1160	36000	1.45				
	75	245	20.00*	36000	4.9		920	36000	1.85				

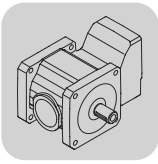

M ₀ [Nm]	n _a [1/min]	M _a [Nm]	i	F _{Ra} ¹⁾ [N]	SEW f _B	M _{DYN} [Nm]	M _a ^{DYN} [Nm]	F _{Ra} ^{DYN} [N]	SEW f _B ^{DYN}			m [kg]		
15	60	325	25.00*	24000	1.60	51	750	24000	1.00	X	BSF 602 CM 90M BSBF 602 CM 90M BSHF 602 CM 90M	68	129	
	75	260	20.00*	24000	2.0		750	24000	1.00	X		68	130	
	100	190	15.00*	24000	2.7		695	24000	1.10			65	131	
	150	123	10.00*	24000	4.2		460	22800	1.65					
	75	265	20.00*	12300	0.95		375	12000	1.00	X	BSF 502 CM 90M BSBF 502 CM 90M BSHF 502 CM 90M	51	125	
	100	195	15.00*	12500	1.30		375	12000	1.00	X		51	126	
	150	128	10.00*	12500	1.95		375	12000	1.00	X		50	127	
	188	107	8.00*	12600	3.0		380	12000	1.10					
	250	80	6.00*	12600	4.0		285	12300	1.45					
	150	131	10.00*	9250	0.95		186	9040	1.00	X	BSF 402 CM 90M BSBF 402 CM 90M BSHF 402 CM 90M	34	121	
	250	81	6.00*	8830	1.95		205	7990	1.00	X		34	122	
	375	54	4.00*	7830	2.5		191	6900	1.05			33	123	
500	40	3.00*	7170	3.1	143	6480	1.30							
21	50	565	30.00*	36000	2.2	74	1680	36000	1.00	X	BSF 802 CM 90L BSBF 802 CM 90L BSHF 802 CM 90L	100	133	
	60	465	25.00*	36000	2.6		1680	36000	1.00			100	134	
	75	370	20.00*	36000	3.3		1340	36000	1.25			97	135	
	100	270	15.00*	36000	4.5		1000	36000	1.70					
	75	380	20.00*	24000	1.35		750	24000	1.00	X	BSF 602 CM 90L BSBF 602 CM 90L BSHF 602 CM 90L	73	129	
	100	280	15.00*	24000	1.85		750	24000	1.00	X		73	130	
	150	184	10.00*	24000	2.8		670	21600	1.10			70	131	
	188	155	8.00*	23100	4.1		555	21200	1.40					
	250	115	6.00*	21300	5.3		415	19900	1.95					
	100	285	15.00*	12300	0.85		375	12000	1.00	X	BSF 502 CM 90L BSBF 502 CM 90L BSHF 502 CM 90L	56	125	
	150	189	10.00*	12500	1.35		375	12000	1.00	X		56	126	
	250	117	6.00*	12600	2.7		410	11400	1.00	X		55	127	
	375	77	4.00*	12400	4.2		275	11400	1.45					
	500	57	3.00*	11400	5.4		205	10700	1.85					
	250	118	6.00*	8580	1.30		205	7990	1.00	X	BSF 402 CM 90L BSBF 402 CM 90L BSHF 402 CM 90L	39	121	
	375	78	4.00*	7660	1.75		200	6840	1.00	X		39	122	
	500	58	3.00*	7050	2.1		183	6210	1.00	X		38	123	
	24	50	635	30.00*	36000		1.95	82	1680	36000	1.00	X	BSF 802 CM 112S BSBF 802 CM 112S BSHF 802 CM 112S	105
60		525	25.00*	36000	2.3	1680	36000		1.00	X	105	134		
75		415	20.00*	36000	3.0	1510	36000		1.10		99	135		
100		305	15.00*	36000	4.0	1120	36000		1.50					
125		260	12.00*	36000	5.3	930	36000		2.1					
75		425	20.00*	24000	1.20	750	24000		1.00	X	BSF 602 CM 112S BSBF 602 CM 112S BSHF 602 CM 112S	75	129	
100		315	15.00*	24000	1.65	750	24000		1.00	X		76	130	
150		205	10.00*	24000	2.5	755	21100		1.00			72	131	
188		174	8.00*	23000	3.7	620	20900		1.25					
250		129	6.00*	21200	4.7	465	19700		1.75					
150		210	10.00*	12400	1.20	375	12000		1.00	X	BSF 502 CM 112S BSBF 502 CM 112S BSHF 502 CM 112S	58	125	
250		131	6.00*	12500	2.4	410	11400		1.00	X		59	126	
375		87	4.00*	12300	3.7	310	11200		1.30			57	127	
500		64	3.00*	11400	4.8	230	10600		1.65					
31		60	700	25.00*	36000	1.75	109		1680	36000	1.00	X	BSF 802 CM 112M BSBF 802 CM 112M BSHF 802 CM 112M	105
	75	555	20.00*	36000	2.2	1680		36000	1.00	X	110	134		
	100	410	15.00*	36000	3.0	1490		36000	1.15		105	135		
	150	265	10.00*	36000	4.6	980		36000	1.70					
	100	420	15.00*	24000	1.25	750		24000	1.00	X	BSF 602 CM 112M BSBF 602 CM 112M BSHF 602 CM 112M	80	129	
	150	275	10.00*	23800	1.90	750		21100	1.00	X		80	130	
250	172	6.00*	21000	3.6	615	19000	1.30		77	131				
375	113	4.00*	18800	5.1	405	17500	1.75							
45	60	1020	25.00*	36000	1.20	158	1680	36000	1.00	X	BSF 802 CM 112L BSBF 802 CM 112L BSHF 802 CM 112L	125	133	
	75	810	20.00*	36000	1.50		1680	36000	1.00	X		125	134	
	100	605	15.00*	36000	2.0		1680	36000	1.00	X		120	135	
	150	395	10.00*	36000	3.1		1440	36000	1.15					
	188	330	8.00*	36000	4.5		1190	36000	1.60					
250	245	6.00*	36000	5.6	890	35300	2.2							
45	100	615	15.00*	24000	0.85	158	750	24000	1.00	X	BSF 602 CM 112L BSBF 602 CM 112L BSHF 602 CM 112L	95	129	
	150	405	10.00*	23100	1.30		750	21100	1.00	X		96	130	
	250	250	6.00*	20700	2.4		800	17200	1.00	X		93	131	
	375	166	4.00*	18600	3.5		595	16600	1.20					
	500	124	3.00*	17200	4.1		445	15700	1.60					

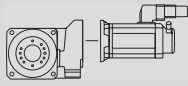

BSF..
BSF.. DS../CM.. [Nm]

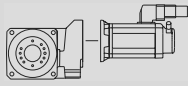
M_0 [Nm]	n_a [1/min]	M_a [Nm]	i	$F_{Ra}^{1)}$ [N]	SEW f_B	M_{DYN} [Nm]	M_a^{DYN} [Nm]	F_{Ra}^{DYN} [N]	SEW f_B^{DYN}			m [kg]	
68	75	1240	20.00*	36000	1.00	240	1680	36000	1.00	X		130	133
	100	920	15.00*	36000	1.30		1680	36000	1.00	X			
	150	610	10.00*	36000	2.0		1680	36000	1.00	X			
	188	505	8.00*	36000	3.0		1800	35800	1.05				
	250	380	6.00*	36000	3.6		1350	33800	1.40				
	375	250	4.00*	33000	5.0		890	30900	2.1				
											BSF 802 CM 112H BBSF 802 CM 112H BSHF 802 CM 112H	125	135

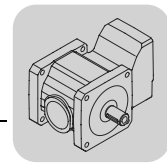

7.3 BSF.. DS../CM.. [Nm]

B..202 DS..

	M _N [Nm]	M _B [Nm]	M _{NOTAUS} [Nm]	i	56M	DFS	56H
					M _a ^{DYN} [Nm]	M _a ^{DYN} [Nm]	M _a ^{DYN} [Nm]
BSF202	40	51	80	25.00*	>51	>51	
	40	51	80	20.00*	>51	>51	
BSKF202	40	51	80	15.00*	48	>51	
	40	51	80	10.00*	31	>51	>51
BSBF202	40	60	90	8.00*	26	53	>60
	40	60	90	6.00*	19	39	>60
BSHF202	40	60	90	4.00*	13	26	53
	40	60	90	3.00*	9.5	19	39

m [kg]	56M	DFS	56H
	56L	56L	56H
BSF202 / BSKF202	6.4	7.4	8.1
BSBF202	6.4	7.4	8.1
BSHF202	6.4	7.4	8.1

n _e = 1500 min ⁻¹ BSF202	iges								
	3	4	6	8	10	15	20	25	
η	0.94	0.94	0.94	0.94	0.91	0.91	0.91	0.91	
J _G 10 ⁻⁴ BSF202	0.76	0.47	0.23	0.14	0.27	0.14	0.09	0.07	
J _G 10 ⁻⁴ BSBF202	0.82	0.50	0.25	0.15	0.27	0.14	0.09	0.07	
J _G 10 ⁻⁴ BSHF202	0.96	0.58	0.28	0.17	0.28	0.15	0.10	0.07	
M _{NOTAUS}	90	90	90	90	80	80	80	80	
M _B	60	60	60	60	51	51	51	51	
n _K	166	175	183	212	160	160	175	172	
F _{Ra} (M _B) BSF202	2460	2780	3280	3680	3990	4200	4200	4200	
F _{Ra} (M _B) BSBF202	2730	3080	3640	4090	4200	4200	4200	4200	
F _{Ra} (M _B) BSHF202	2380	2690	3180	3570	3870	4200	4200	4200	
M _N	40	40	40	40	40	40	40	40	
F _{Ra} (M _N) BSF202	2690	3010	3510	3920	4140	4200	4200	4200	
F _{Ra} (M _N) BSBF202	2990	3340	3900	4200	4200	4200	4200	4200	
F _{Ra} (M _N) BSHF202	2610	2920	3410	3800	4020	4200	4200	4200	
M _{THERM} M1	a ₀	4.1	4.26	4.5	4.7	3.31	4.09	3.77	3.67
	a ₁	-0.011	-0.014	-0.019	-0.022	-0.057	-0.076	-0.089	-0.098
	a ₂	77457	76815	75905	75309	47656	46683	46508	46334
M _{THERM} M2/M4	a ₀	14.47	20.11	30.66	37.13	52.73	56.52	53.03	47.99
	a ₁	-0.02	-0.028	-0.042	-0.052	-0.146	-0.189	-0.21	-0.221
	a ₂	66498	60846	51203	46240	26432	28536	32477	36133
M _{THERM} M3/M5/M6	a ₀	6.12	7.52	10.05	12.1	19.7	31.62	42.49	51.81
	a ₁	-0.013	-0.017	-0.024	-0.029	-0.083	-0.125	-0.161	-0.191
	a ₂	75323	73532	70662	68596	39837	34857	30764	27469

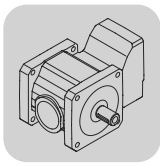
BSF..
BSF.. DS../CM.. [Nm]
B..302 DS../CM..

	M_N [Nm]	M_B [Nm]	M_{NOTAUS} [Nm]	i	DFS			CFM	
					56M M_a^{DYN} [Nm]	56L M_a^{DYN} [Nm]	56H M_a^{DYN} [Nm]	71S M_a^{DYN} [Nm]	71M M_a^{DYN} [Nm]
BSF302	80	112	168	30.00*	96	>112			
	80	112	168	25.00*	80	>112	>112		
BSKF302	80	112	168	20.00*	63	>112	>112	>112	
	80	112	168	15.00*	47	96	>112	>112	>112
BSBF302	72	108	162	10.00*	31	63	>108	>108	>108
BSHF302	80	120	180	8.00*	26	53	106	>120	>120
	80	120	180	6.00*	19	39	79	99	>120
	76	114	171	4.00*			52	66	86
	68	102	153	3.00*				49	64

m [kg]	DFS			CFM	
	56M	56L	56H	71S	71M
BSF302 / BSKF302	8.4	9.4	10	16	18
BSBF302	8.7	9.7	10	16	19
BSHF302	8.3	9.3	10	16	18

$n_e = 1500 \text{ min}^{-1}$ BSF302	iges									
	3	4	6	8	10	15	20	25	30	
η	0.94	0.94	0.94	0.94	0.91	0.91	0.91	0.91	0.91	
$J_G 10^{-4}$ BSF302	1.6	0.97	0.48	0.29	0.55	0.29	0.19	0.13	0.10	
$J_G 10^{-4}$ BSBF302	1.9	1.1	0.55	0.33	0.58	0.30	0.19	0.14	0.10	
$J_G 10^{-4}$ BSHF302	1.8	1.1	0.52	0.31	0.56	0.30	0.19	0.13	0.10	
M_{NOTAUS}	153	171	180	180	162	168	168	168	168	
M_B	102	114	120	120	108	112	112	112	112	
η_K	133	75	83	87	40	33	35	36	36	
$F_{Ra}(M_B)$ BSF302	4240	4650	4660	4660	4840	4780	4780	4780	4780	
$F_{Ra}(M_B)$ BSBF302	4660	5120	5960	6000	6000	6000	6000	6000	6000	
$F_{Ra}(M_B)$ BSHF302	4100	4500	5240	5370	5470	5440	5440	5440	5440	
M_N	68	76	80	80	72	80	80	80	80	
$F_{Ra}(M_N)$ BSF302	4520	4970	5160	5160	5230	5160	5160	5160	5160	
$F_{Ra}(M_N)$ BSBF302	4980	5470	6000	6000	6000	6000	6000	6000	6000	
$F_{Ra}(M_N)$ BSHF302	4380	4810	5570	5660	5700	5660	5660	5660	5660	
M_{THERM} M1	a_0	10.61	11.44	12.77	13.72	17.47	23.3	28.02	30.93	33.58
	a_1	-0.02	-0.025	-0.033	-0.038	-0.106	-0.146	-0.176	-0.198	-0.216
	a_2	101982	100944	99436	98463	60873	58348	56577	55589	54719
M_{THERM} M2/M4	a_0	29.34	39.04	48.54	54.94	82.08	101.6	121.97	137.52	149.62
	a_1	-0.039	-0.054	-0.075	-0.091	-0.261	-0.363	-0.451	-0.52	-0.574
	a_2	87407	80239	75064	72074	41142	38252	33554	30171	27671
M_{THERM} M3/M5/M6	a_0	16.53	20.24	26.76	31.93	61.94	94.43	108.88	119.67	127.99
	a_1	-0.026	-0.034	-0.048	-0.059	-0.192	-0.295	-0.358	-0.407	-0.446
	a_2	97370	94323	89388	85770	43856	33419	30285	28099	26539

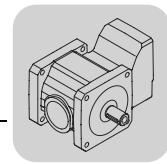

B..402 DS../CM..

	M _N [Nm]	M _B [Nm]	M _{NOTAUS} [Nm]	i	DFS	CFM					
					56H M _{a DYN} [Nm]	71S M _{a DYN} [Nm]	71M M _{a DYN} [Nm]	71L M _{a DYN} [Nm]	90S M _{a DYN} [Nm]	90M M _{a DYN} [Nm]	90L M _{a DYN} [Nm]
BSF402	160	225	335	30.00*	>225						
	160	225	335	25.00*	>225	>225	>225				
BSKF402	152	220	330	20.00*	>220	>220	>220	>220			
	140	210	315	15.00*	191	>210	>210	>210	>210		
BSBF402	124	186	275	10.00*	126	159	>186	>186	>186	>186	
BSHF402	160	210	320	8.00*	105	131	171	>210	>210		
	156	205	310	6.00*	78	98	128	188	>205	>205	>205
	136	200	300	4.00*		65	85	125	145	191	>200
	122	183	270	3.00*				93	108	143	>183

m [kg]	DFS 56H	71S	71M	CFM			
				71L	90S	90M	90L
BSF402 / BSKF402	15	20	22	25	31	34	39
BSBF402	15	21	22	26	32	34	39
BSHF402	14	20	21	25	30	33	38

n _e = 1500 min ⁻¹ BSF402	iges									
	3	4	6	8	10	15	20	25	30	
η	0.94	0.94	0.94	0.94	0.91	0.91	0.91	0.91	0.92	
J _G 10 ⁻⁴ BSF402	5.2	3.2	1.5	0.92	1.9	1.0	0.62	0.45	0.34	
J _G 10 ⁻⁴ BSBF402	6.0	3.6	1.8	1.0	2.0	1.0	0.64	0.46	0.35	
J _G 10 ⁻⁴ BSHF402	5.7	3.5	1.7	1.0	2.0	1.0	0.64	0.46	0.35	
M _{NOTAUS}	270	300	310	320	275	315	330	335	335	
M _B	183	200	205	210	186	210	220	225	225	
η _K	100	100	100	87	30	20	20	20	20	
F _{Ra} (M _B) BSF402	6210	6840	7990	8900	9040	8920	8870	8840	8840	
F _{Ra} (M _B) BSBF402	7130	7850	9180	10200	10800	10800	10800	10800	10800	
F _{Ra} (M _B) BSHF402	6100	6720	7860	8760	10000	10800	10800	10800	10800	
M _N	122	136	156	160	124	140	152	160	160	
F _{Ra} (M _N) BSF402	6620	7270	8320	9140	9270	9220	9170	9140	9140	
F _{Ra} (M _N) BSBF402	7600	8350	9560	10600	10800	10800	10800	10800	10800	
F _{Ra} (M _N) BSHF402	6530	7170	8210	9120	10500	10800	10800	10800	10800	
M _{THERM} M1	a ₀	16.64	17.96	19.78	21.09	22.39	29.19	34.34	38.33	41.83
	a ₁	-0.042	-0.052	-0.066	-0.077	-0.211	-0.282	-0.335	-0.375	-0.407
	a ₂	136375	135265	133791	132801	82904	80694	79192	78100	77194
M _{THERM} M2/M4	a ₀	23.96	27.92	33.62	37.83	53.97	74.18	89.99	101.09	110.31
	a ₁	-0.064	-0.082	-0.11	-0.131	-0.374	-0.523	-0.638	-0.725	-0.794
	a ₂	131323	129034	126042	124010	74730	70371	67275	65289	63679
M _{THERM} M3/M5/M6	a ₀	16.8	18.77	21.69	23.79	28.11	37.7	45.42	51.01	55.87
	a ₁	-0.043	-0.053	-0.07	-0.082	-0.227	-0.308	-0.37	-0.417	-0.455
	a ₂	134151	132596	130498	129114	79870	77196	75192	73859	72752

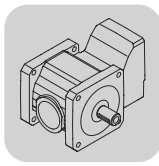
BSF..
BSF.. DS../CM.. [Nm]
B..502 CM..

	M_N [Nm]	M_B [Nm]	M_{NOTAUS} [Nm]	i	71S	71M	71L	CFM	90M	90L	112S
					M_a^{DYN} [Nm]	M_a^{DYN} [Nm]	M_a^{DYN} [Nm]	90S M_a^{DYN} [Nm]	M_a^{DYN} [Nm]	M_a^{DYN} [Nm]	M_a^{DYN} [Nm]
BSF502	250	375	560	30.00*	>375	>375					
	250	375	560	25.00*	>375	>375	>375	>375			
BSKF502	250	375	560	20.00*	320	>375	>375	>375	>375		
	250	375	560	15.00*	235	310	>375	>375	>375	>375	
BSBF502	300	410	615	12.00*	197	255					
BSHF502	250	375	560	10.00*	156	205	300	350	>375	>375	>375
	320	420	640	8.00*	130	170	250	290	380		
	320	410	640	6.00*	97	127	187	215	285	>410	>410
	320	400	640	4.00*	64	84	124	143	190	275	310
	310	385	620	3.00*						205	230

m [kg]	71S	71M	71L	CFM	90M	90L	112S
BSF502 / BSKF502	38	39	43	48	51	56	58
BSBF502	38	39	43	49	51	56	59
BSHF502	37	38	42	47	50	55	57

$n_e = 1500 \text{ min}^{-1}$ BSF502	iges											
	3	4	6	8	10	12	15	20	25	30	35	
η	0.94	0.94	0.94	0.94	0.91	0.94	0.91	0.91	0.91	0.91	0.91	
$J_G 10^{-4}$ BSF502	12	7.3	3.6	6.2	4.0	1.1	2.1	1.3	0.92	0.70	0.56	
$J_G 10^{-4}$ BSBF502	13	7.8	3.8	6.3	4.0	1.1	2.1	1.3	0.93	0.71	0.56	
$J_G 10^{-4}$ BSHF502	13	7.6	3.7	6.3	4.0	1.1	2.1	1.3	0.93	0.71	0.56	
M_{NOTAUS}	620	640	640	640	560	615	560	560	560	560	560	
M_B	385	400	410	420	375	410	375	375	375	375	375	
n_K	233	200	183	162	130	183	133	135	132	136	142	
$F_{Ra}(M_B)$ BSF502	8500	9540	11400	11900	12000	11900	12000	12000	12000	12000	12000	
$F_{Ra}(M_B)$ BSBF502	10300	11600	13800	14400	14400	14400	14400	14400	14400	14400	14400	
$F_{Ra}(M_B)$ BSHF502	9210	10300	12300	13900	14400	14400	14400	14400	14400	14400	14400	
M_N	310	320	320	320	250	300	250	250	250	250	250	
$F_{Ra}(M_N)$ BSF502	9580	10700	12200	12200	12300	12200	12300	12300	12300	12300	12300	
$F_{Ra}(M_N)$ BSBF502	11600	13000	14400	14400	14400	14400	14400	14400	14400	14400	14400	
$F_{Ra}(M_N)$ BSHF502	10400	11600	13700	14400	14400	14400	14400	14400	14400	14400	14400	
M_{THERM} M1	a_0	21.29	20.57	19.77	19.26	-6.62	18.42	-8.98	-10.77	-11.48	-12.28	-12.89
	a_1	-0.055	-0.065	-0.08	-0.09	-0.203	-0.103	-0.257	-0.295	-0.324	-0.345	-0.362
	a_2	184165	183623	182775	182213	120320	181624	119313	118759	118189	117868	117623
M_{THERM} M2/M4	a_0	18.47	16.99	14.92	13.39	-17.47	11.52	-22.97	-26.04	-28.42	-30.16	-31.46
	a_1	-0.081	-0.097	-0.121	-0.137	-0.316	-0.158	-0.403	-0.466	-0.511	-0.546	-0.574
	a_2	183632	182939	181967	181401	119454	180702	118384	117558	117063	116700	116419
M_{THERM} M3/M5/M6	a_0	32.71	34.95	37.6	39.07	22.51	40.77	27.69	31.72	34.29	36.58	38.29
	a_1	-0.077	-0.094	-0.12	-0.138	-0.334	-0.162	-0.441	-0.518	-0.575	-0.62	-0.655
	a_2	180058	178708	177200	176411	115909	175563	114160	112896	112134	111510	111052

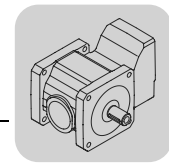

B..602 CM..

	M _N [Nm]	M _B [Nm]	M _{NOTAUS} [Nm]	i	CFM									
					71S M _a ^{DYN} [Nm]	71M M _a ^{DYN} [Nm]	71L M _a ^{DYN} [Nm]	90S M _a ^{DYN} [Nm]	90M M _a ^{DYN} [Nm]	90L M _a ^{DYN} [Nm]	112S M _a ^{DYN} [Nm]	112M M _a ^{DYN} [Nm]	112L M _a ^{DYN} [Nm]	
BSF602	520	750	1120	40.00*	640	>750								
	520	750	1120	35.00*	560	730								
BSKF602	520	750	1120	30.00*	475	620	>750	>750						
	520	750	1120	25.00*	395	515	>750	>750	>750					
BSBF602	520	750	1120	20.00*	315	410	605	705	>750	>750	>750			
	520	750	1120	15.00*			450	525	695	>750	>750	>750	>750	>750
BSHF602	550	775	1160	12.00*	195	255	375	435						
	520	750	1120	10.00*					460	670	755	>750	>750	>750
	640	780	1280	8.00*	128	168	250	285	380	555	620			
	610	800	1220	6.00*			184	215	285	415	465	615	>800	
	575	715	1150	4.00*					188	275	305	405	595	
	505	700	1050	3.00*								305	445	

m [kg]	71S	71M	71L	90S	90M	90L	112S	112M	112L
BSF602 / BSKF602	55	56	60	65	68	73	75	80	95
BSBF602	55	56	60	66	68	73	76	80	96
BSHF602	52	53	57	62	65	70	72	77	93

7

n _e = 1500 min ⁻¹ BSF602	iges												
	3	4	6	8	10	12	15	20	25	30	35	40	
η	0.94	0.94	0.94	0.94	0.92	0.94	0.92	0.92	0.92	0.92	0.92	0.92	0.92
J _G 10 ⁻⁴ BSF602	35	21	10	6.2	9.9	2.9	5.3	3.5	2.5	1.7	1.4	1.4	1.1
J _G 10 ⁻⁴ BSBF602	37	22	11	6.5	10	3.1	5.4	3.5	2.5	1.7	1.4	1.4	1.1
J _G 10 ⁻⁴ BSHF602	37	22	11	6.5	10	3.1	5.4	3.5	2.5	1.7	1.4	1.4	1.1
M _{NOTAUS}	1050	1150	1220	1280	1120	1160	1120	1120	1120	1120	1120	1120	1120
M _B	700	715	800	780	750	775	750	750	750	750	750	750	750
n _K	133	175	100	137	60	158	53	55	56	56	60	52	52
F _{Ra} (M _B) BSF602	13400	15200	17200	19800	21100	23300	24000	24000	24000	24000	24000	24000	24000
F _{Ra} (M _B) BSBF602	15400	17500	19800	22900	24000	24000	24000	24000	24000	24000	24000	24000	24000
F _{Ra} (M _B) BSHF602	13800	15700	17800	20500	21800	24000	24000	24000	24000	24000	24000	24000	24000
M _N	505	575	610	640	520	550	520	520	520	520	520	520	520
F _{Ra} (M _N) BSF602	15400	16700	19000	20800	22400	24000	24000	24000	24000	24000	24000	24000	24000
F _{Ra} (M _N) BSBF602	17600	19100	21700	23800	24000	24000	24000	24000	24000	24000	24000	24000	24000
F _{Ra} (M _N) BSHF602	15900	17200	19600	21500	23100	24000	24000	24000	24000	24000	24000	24000	24000
M _{THERM} M1	a ₀	-1.22	-3.35	-6.35	-8.4	-47.5	-11.01	-55.05	-60.08	-63.71	-66.47	-68.08	-69.66
	a ₁	-0.06	-0.071	-0.086	-0.097	-0.236	-0.111	-0.294	-0.333	-0.362	-0.383	-0.402	-0.415
	a ₂	258182	257389	256315	255637	167324	254840	166158	165439	164961	164630	164287	164073
M _{THERM} M2/M4	a ₀	17.38	17.94	18.5	18.73	-14.52	18.58	-15.4	-17.9	-18.71	-19.57	-20.31	-20.99
	a ₁	-0.144	-0.178	-0.23	-0.267	-0.678	-0.314	-0.892	-1.036	-1.146	-1.23	-1.295	-1.347
	a ₂	253939	252543	250689	249529	162357	248244	160319	159395	158560	158019	157620	157322
M _{THERM} M3/M5/M6	a ₀	36.73	42.42	50.09	54.77	41.59	60.3	47.82	52.82	57.42	60.84	64.77	67.1
	a ₁	-0.132	-0.166	-0.218	-0.255	-0.662	-0.303	-0.869	-1.018	-1.13	-1.217	-1.29	-1.346
	a ₂	247267	244809	241723	239958	155420	237995	154910	154092	153134	152406	151662	151214

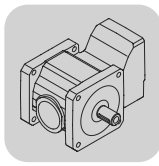
BSF..
BSF.. DS./CM.. [Nm]
B..802 CM..

	M_N [Nm]	M_B [Nm]	M_{NOTAUS} [Nm]	i	CFM						
					90M M_a^{DYN} [Nm]	90L M_a^{DYN} [Nm]	112S M_a^{DYN} [Nm]	112M M_a^{DYN} [Nm]	112L M_a^{DYN} [Nm]	112H M_a^{DYN} [Nm]	
BSF802	1220	1680	2520	40.00*	>1680						
	1220	1680	2520	35.00*	1630						
BSKF802	1220	1680	2520	30.00*	1390	>1680	>1680				
	1220	1680	2520	25.00*	1160	1680	>1680	>1680	>1680	>1680	
BSBF802	1220	1680	2520	20.00*	920	1340	1510	>1680	>1680	>1680	>1680
	1220	1680	2520	15.00*	685	1000	1120	1490	>1680	>1680	>1680
BSHF802	1360	1910	2860	12.00*	570	830	930				
	1220	1680	2520	10.00*				980	1440	>1680	
	1500	1910	3000	8.00*	375	550	615	810	1190	1800	
	1370	1910	2860	6.00*	280	410	460	610	890	1350	
	1240	1860	2790	4.00*				400	590	890	

m [kg]	CFM					
	90M	90L	112S	112M	112L	112H
BSF802 / BSKF802	96	100	105	105	125	130
BSBF802	97	100	105	110	125	130
BSHF802	92	97	99	105	120	125

$n_e = 1500 \text{ min}^{-1}$ BSF802	iges											
	4	6	8	10	12	15	20	25	30	35	40	
η	0.94	0.94	0.94	0.92	0.94	0.92	0.92	0.92	0.92	0.92	0.92	0.92
$J_G 10^{-4}$ BSF802	70	34	21	32	11	18	12	8.5	6.5	5.1	4.2	
$J_G 10^{-4}$ BSBF802	78	38	23	33	12	18	12	8.7	6.7	5.2	4.3	
$J_G 10^{-4}$ BSHF802	82	40	24	34	12	19	12	8.8	6.7	5.3	4.3	
M_{NOTAUS}	2790	2860	3000	2520	2860	2520	2520	2520	2520	2520	2520	
M_B	1860	1910	1910	1680	1910	1680	1680	1680	1680	1680	1680	
η_K	75	66	87	60	75	60	65	60	63	65	67	
$F_{Ra}(M_B)$ BSF802	24400	29300	33500	36000	36000	36000	36000	36000	36000	36000	36000	
$F_{Ra}(M_B)$ BSBF802	28900	34800	36000	36000	36000	36000	36000	36000	36000	36000	36000	
$F_{Ra}(M_B)$ BSHF802	24300	29300	33500	36000	36000	36000	36000	36000	36000	36000	36000	
M_N	1240	1370	1500	1220	1360	1220	1220	1220	1220	1220	1220	
$F_{Ra}(M_N)$ BSF802	29800	33800	36000	36000	36000	36000	36000	36000	36000	36000	36000	
$F_{Ra}(M_N)$ BSBF802	35000	36000	36000	36000	36000	36000	36000	36000	36000	36000	36000	
$F_{Ra}(M_N)$ BSHF802	29700	33700	36000	36000	36000	36000	36000	36000	36000	36000	36000	
M_{THERM} M1	a_0	36.53	38.78	40.01	-23.29	41.33	-23.52	-23.77	-24.68	-25.17	-25.61	-26.02
	a_1	-0.257	-0.322	-0.368	-0.92	-0.427	-1.178	-1.359	-1.491	-1.592	-1.671	-1.735
	a_2	380872	379127	378029	247749	376719	245862	244661	243925	243363	242945	242626
M_{THERM} M2/M4	a_0	85.55	97.23	104.52	61.41	112.55	79.26	87.97	94.41	99.42	102.3	107.05
	a_1	-0.552	-0.72	-0.839	-2.162	-0.993	-2.866	-3.354	-3.718	-3.997	-4.214	-4.402
	a_2	372271	369115	367166	238512	364991	235221	233524	232349	231420	230843	230135
M_{THERM} M3/M5/M6	a_0	94.47	110.31	120.39	91.96	131.79	119.05	136.38	148.58	157.99	165.07	170.79
	a_1	-0.447	-0.584	-0.682	-1.769	-0.808	-2.352	-2.767	-3.076	-3.315	-3.503	-3.656
	a_2	370986	367673	365688	237008	363576	233398	231226	229783	228644	227831	227184

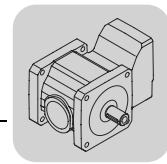

7.4 BSF.. EBH.. [Nm]

B..202 EBH..

	M_N [Nm]	M_B [Nm]	M_{NOTAUS} [Nm]	i	EBH			
					03		04	
					M_N [Nm]	M_B [Nm]	M_N [Nm]	M_B [Nm]
BSF202	40	51	80	25.00*	51	51	40	51
	40	51	80	20.00*	40	51	40	51
BSKF202	40	51	80	15.00*	40	51	40	51
	40	51	80	10.00*	40	51	40	51
BSBF202	40	60	90	8.00*	40	60	40	60
	40	60	90	6.00*	40	60	40	60
BSHF202	40	60	90	4.00*	40	60	40	60
	40	60	90	3.00*	40	60	40	60

m [kg]	EBH	
	03	04
BSF202 / BSKF202	5.3	5.3
BSBF202	5.3	5.3
BSHF202	5.3	5.3

$n_e = 1500 \text{ min}^{-1}$ BSF202EBH03 BSF202EBH04	iges							
	3	4	6	8	10	15	20	25
η	0.93	0.93	0.93	0.93	0.89	0.89	0.88	0.88
$J_G 10^{-4}$ BSF202	1.8	1.5	1.3	1.2	1.3	1.2	1.1	1.1
$J_G 10^{-4}$ BSBF202	1.9	1.5	1.3	1.2	1.3	1.2	1.1	1.1
$J_G 10^{-4}$ BSHF202	2.0	1.6	1.3	1.2	1.3	1.2	1.1	1.1
M_{NOTAUS}	90	90	90	90	80	80	80	80
M_B	60	60	60	60	51	51	51	51
n_K	166	175	183	212	160	160	175	172
$F_{Ra}(M_B)$ BSF202	2460	2780	3280	3680	3990	4200	4200	4200
$F_{Ra}(M_B)$ BSBF202	2730	3080	3640	4090	4200	4200	4200	4200
$F_{Ra}(M_B)$ BSHF202	2380	2690	3180	3570	3870	4200	4200	4200
M_N	40	40	40	40	40	40	40	51
$F_{Ra}(M_N)$ BSF202	2690	3010	3510	3920	4140	4200	4200	4200
$F_{Ra}(M_N)$ BSBF202	2990	3340	3900	4200	4200	4200	4200	4200
$F_{Ra}(M_N)$ BSHF202	2610	2920	3410	3800	4020	4200	4200	4200

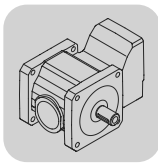

B..302 EBH..

	M_N [Nm]	M_B [Nm]	M_{NOTAUS} [Nm]	i	EBH					
					03		04		05	
					M_N [Nm]	M_B [Nm]	M_N [Nm]	M_B [Nm]	M_N [Nm]	M_B [Nm]
BSF302	80	112	168	30.00*	80	112	80	112		
	80	112	168	25.00*	80	112	80	112		
BSKF302	80	112	168	20.00*	80	112	80	112	80	112
	80	112	168	15.00*	80	112	80	112	80	112
BSBF302	72	108	162	10.00*	72	108	72	108	72	108
BSHF302	80	120	180	8.00*	80	120	80	120	80	120
	80	120	180	6.00*	74	111	74	111	80	120
	76	114	171	4.00*	62	93	62	93	76	109
	68	102	153	3.00*	46	69	46	69	68	82

m [kg]	EBH		
	03	04	05
BSF302 / BSKF302	7.3	7.3	8.8
BSBF302	7.6	7.6	9.2
BSHF302	7.2	7.2	8.8

$n_e = 1500 \text{ min}^{-1}$ BSF302EBH03 BSF302EBH04	iges								
	3	4	6	8	10	15	20	25	30
η	0.93	0.94	0.94	0.94	0.90	0.90	0.90	0.90	0.90
$J_G 10^{-4}$ BSF302	2.6	2.0	1.5	1.3	1.6	1.3	1.2	1.2	1.1
$J_G 10^{-4}$ BSBF302	2.9	2.2	1.6	1.4	1.6	1.3	1.2	1.2	1.1
$J_G 10^{-4}$ BSHF302	2.8	2.1	1.6	1.4	1.6	1.3	1.2	1.2	1.1
M_{NOTAUS}	103	139	166	180	162	168	168	168	168
M_B	69	93	111	120	108	112	112	112	112
n_K	266	100	66	50	30	33	35	36	36
$F_{Ra}(M_B)$ BSF302	4520	4830	4800	4660	4840	4780	4780	4780	4780
$F_{Ra}(M_B)$ BSBF302	4970	5310	6000	6000	6000	6000	6000	6000	6000
$F_{Ra}(M_B)$ BSHF302	4370	4670	5310	5370	5470	5440	5440	5440	5440
M_N	46	62	74	80	72	80	80	80	80
$F_{Ra}(M_N)$ BSF302	4710	5090	5210	5160	5230	5160	5160	5160	5160
$F_{Ra}(M_N)$ BSBF302	5190	5600	6000	6000	6000	6000	6000	6000	6000
$F_{Ra}(M_N)$ BSHF302	4560	4930	5620	5660	5700	5660	5660	5660	5660

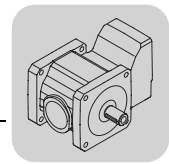
$n_e = 1500 \text{ min}^{-1}$ BSF302EBH05	iges								
	3	4	6	8	10	15	20	25	30
η	0.93	0.93	0.93	0.93	0.89	0.89	0.89	-	-
$J_G 10^{-4}$ BSF302	6.5	5.9	5.4	5.2	5.5	5.2	5.1	-	-
$J_G 10^{-4}$ BSBF302	6.8	6.1	5.5	5.3	5.5	5.2	5.1	-	-
$J_G 10^{-4}$ BSHF302	6.7	6.0	5.5	5.3	5.5	5.2	5.1	-	-
M_{NOTAUS}	136	163	180	180	162	168	168	-	-
M_B	82	109	120	120	108	112	112	-	-
n_K	266	100	83	87	30	33	35	-	-
$F_{Ra}(M_B)$ BSF302	4410	4690	4660	4660	4840	4780	4780	-	-
$F_{Ra}(M_B)$ BSBF302	4850	5160	5960	6000	6000	6000	6000	-	-
$F_{Ra}(M_B)$ BSHF302	4270	4540	5240	5370	5470	5440	5440	-	-
M_N	68	76	80	80	72	80	80	-	-
$F_{Ra}(M_N)$ BSF302	4520	4970	5160	5160	5230	5160	5160	-	-
$F_{Ra}(M_N)$ BSBF302	4980	5470	6000	6000	6000	6000	6000	-	-
$F_{Ra}(M_N)$ BSHF302	4380	4810	5570	5660	5700	5660	5660	-	-



B..402 EBH..

	M _N [Nm]	M _B [Nm]	M _{NOTAUS} [Nm]	i	EBH									
					03		04		05		06		07	
					M _N [Nm]	M _B [Nm]	M _N [Nm]	M _B [Nm]	M _N [Nm]	M _B [Nm]	M _N [Nm]	M _B [Nm]	M _N [Nm]	M _B [Nm]
BSF402	160	225	335	30.00*	160	225	160	225						
	160	225	335	25.00*	160	225	160	225	160	225				
BSKF402	152	220	330	20.00*	152	220	152	220	152	220	152	220	152	220
	140	210	315	15.00*	140	210	140	210	140	210	140	210	140	210
BSBF402	124	186	275	10.00*	124	186	124	186	124	186	124	186	124	186
BSHF402	160	210	320	8.00*	104	156	104	156	160	210	160	210	160	210
	156	205	310	6.00*	92	138	92	138	156	205	156	205	156	205
	136	200	300	4.00*	61	92	61	92	136	200	136	200	136	200
	122	183	270	3.00*					109	164	122	183	122	183

m [kg]	EBH				
	03	04	05	06	07
BSF402 / BSKF402	12	12	14	15	15
BSBF402	12	12	14	16	16
BSHF402	11	11	13	15	15

n _e = 1500 min ⁻¹ BSF402EBH03 BSF402EBH04	iges								
	3	4	6	8	10	15	20	25	30
η	-	0.92	0.93	0.93	0.90	0.90	0.90	0.90	0.90
J _G 10 ⁻⁴ BSF402	-	4.2	2.6	2.0	3.0	2.0	1.7	1.5	1.4
J _G 10 ⁻⁴ BSBF402	-	4.7	2.8	2.1	3.0	2.1	1.7	1.5	1.4
J _G 10 ⁻⁴ BSHF402	-	4.5	2.7	2.0	3.0	2.1	1.7	1.5	1.4
M _{NOTAUS}	-	138	205	230	275	315	330	335	335
M _B	-	92	138	156	186	210	220	225	225
n _K	-	225	83	50	30	20	20	20	20
F _{Ra} (M _B)BSF402	-	7570	8440	9160	9040	8920	8870	8840	8840
F _{Ra} (M _B)BSBF402	-	8690	9700	10600	10800	10800	10800	10800	10800
F _{Ra} (M _B)BSHF402	-	7490	8340	9150	10000	10800	10800	10800	10800
M _N	-	61	92	104	124	140	152	160	160
F _{Ra} (M _N)BSF402	-	7780	8750	9320	9270	9220	9170	9140	9140
F _{Ra} (M _N)BSBF402	-	8930	10100	10800	10800	10800	10800	10800	10800
F _{Ra} (M _N)BSHF402	-	7710	8660	9520	10500	10800	10800	10800	10800

n _e = 1500 min ⁻¹ BSF402EBH05	iges								
	3	4	6	8	10	15	20	25	30
η	0.93	0.94	0.94	0.94	0.89	0.89	0.90	0.89	-
J _G 10 ⁻⁴ BSF402	10	8.1	6.5	5.9	6.9	5.9	5.6	5.4	-
J _G 10 ⁻⁴ BSBF402	11	8.6	6.7	6.0	6.9	6.0	5.6	5.4	-
J _G 10 ⁻⁴ BSHF402	11	8.4	6.6	5.9	6.9	6.0	5.6	5.4	-
M _{NOTAUS}	245	300	310	320	275	315	330	335	-
M _B	164	200	205	210	186	210	220	225	-
n _K	166	100	100	87	30	20	20	20	-
F _{Ra} (M _B)BSF402	6340	6840	7990	8900	9040	8920	8870	8840	-
F _{Ra} (M _B)BSBF402	7270	7850	9180	10200	10800	10800	10800	10800	-
F _{Ra} (M _B)BSHF402	6230	6720	7860	8760	10000	10800	10800	10800	-
M _N	109	136	156	160	124	140	152	160	-
F _{Ra} (M _N)BSF402	6700	7270	8320	9140	9270	9220	9170	9140	-
F _{Ra} (M _N)BSBF402	7700	8350	9560	10600	10800	10800	10800	10800	-
F _{Ra} (M _N)BSHF402	6620	7170	8210	9120	10500	10800	10800	10800	-

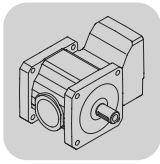

BSF..
BSF.. EBH.. [Nm]

$n_e = 1500 \text{ min}^{-1}$ BSF402EBH06 BSF402EBH07	iges								
	3	4	6	8	10	15	20	25	30
η	0.93	0.93	0.94	0.93	0.89	0.89	0.89	-	-
$J_G 10^{-4}$ BSF402	14	12	10	9.8	11	9.8	9.5	-	-
$J_G 10^{-4}$ BSBF402	15	12	11	9.9	11	9.9	9.5	-	-
$J_G 10^{-4}$ BSHF402	15	12	11	9.8	11	9.9	9.5	-	-
M_{NOTAUS}	270	300	310	320	275	315	330	-	-
M_B	183	200	205	210	186	210	220	-	-
n_K	100	100	100	87	30	20	20	-	-
$F_{Ra}(M_B)$ BSF402	6210	6840	7990	8900	9040	8920	8870	-	-
$F_{Ra}(M_B)$ BSBF402	7130	7850	9180	10200	10800	10800	10800	-	-
$F_{Ra}(M_B)$ BSHF402	6100	6720	7860	8760	10000	10800	10800	-	-
M_N	122	136	156	160	124	140	152	-	-
$F_{Ra}(M_N)$ BSF402	6620	7270	8320	9140	9270	9220	9170	-	-
$F_{Ra}(M_N)$ BSBF402	7600	8350	9560	10600	10800	10800	10800	-	-
$F_{Ra}(M_N)$ BSHF402	6530	7170	8210	9120	10500	10800	10800	-	-

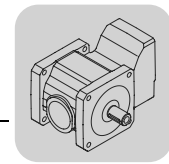

B..502 EBH..

	EBH															
	M _N [Nm]	M _B [Nm]	M _{NOTAUS} [Nm]	i	03		04		05		06		07		08	
					M _N [Nm]	M _B [Nm]	M _N [Nm]	M _B [Nm]	M _N [Nm]	M _B [Nm]	M _N [Nm]	M _B [Nm]	M _N [Nm]	M _B [Nm]	M _N [Nm]	M _B [Nm]
BSF502	250	375	560	35.00*	250	375	250	375								
	250	375	560	30.00*	250	375	250	375	250	375						
BSKF502	250	375	560	25.00*	250	375	250	375	250	375	250	375	250	375		
	250	375	560	20.00*	250	375	250	375	250	375	250	375	250	375	250	375
BSBF502	250	375	560	15.00*	220	330	220	330	250	375	250	375	250	375	250	375
	300	410	615	12.00*	137	205	137	205	260	325						
BSHF502	250	375	560	10.00*	147	220	147	220	250	375	250	375	250	375	250	375
	320	420	640	8.00*					235	355	320	420	320	420	320	420
	320	410	640	6.00*					215	325	320	410	320	410	320	410
	320	400	640	4.00*					145	220	270	400	270	400	320	400
	310	385	620	3.00*							210	315	210	315	310	370

m [kg]	EBH					
	03	04	05	06	07	08
BSF502 / BSKF502	30	30	32	35	35	39
BSBF502	31	31	33	35	35	39
BSHF502	29	29	31	34	34	38

n _e = 1500 min ⁻¹ BSF502EBH03 BSF502EBH04	iges											
	3	4	6	8	10	12	15	20	25	30	35	
η	-	-	-	-	0.89	0.93	0.90	0.90	0.90	0.90	0.90	
J _G 10 ⁻⁴ BSF502	-	-	-	-	5.0	2.1	3.1	2.3	2.0	1.7	1.6	
J _G 10 ⁻⁴ BSBF502	-	-	-	-	5.1	2.2	3.2	2.3	2.0	1.8	1.6	
J _G 10 ⁻⁴ BSHF502	-	-	-	-	5.0	2.1	3.1	2.3	2.0	1.7	1.6	
M _{NOTAUS}	-	-	-	-	330	305	495	560	560	560	560	
M _B	-	-	-	-	220	205	330	375	375	375	375	
η _K	-	-	-	-	180	33	60	40	40	33	31	
F _{Ra} (M _B)BSF502	-	-	-	-	12400	12400	12100	12000	12000	12000	12000	
F _{Ra} (M _B)BSBF502	-	-	-	-	14400	14400	14400	14400	14400	14400	14400	
F _{Ra} (M _B)BSHF502	-	-	-	-	14400	14400	14400	14400	14400	14400	14400	
M _N	-	-	-	-	147	137	220	250	250	250	250	
F _{Ra} (M _N)BSF502	-	-	-	-	12500	12500	12400	12300	12300	12300	12300	
F _{Ra} (M _N)BSBF502	-	-	-	-	14400	14400	14400	14400	14400	14400	14400	
F _{Ra} (M _N)BSHF502	-	-	-	-	14400	14400	14400	14400	14400	14400	14400	

n _e = 1500 min ⁻¹ BSF502EBH05	iges											
	3	4	6	8	10	12	15	20	25	30	35	
η	-	0.93	0.93	0.93	0.90	0.93	0.90	0.90	0.90	0.89	-	
J _G 10 ⁻⁴ BSF502	-	12	8.5	11	8.9	6.0	7.0	6.2	5.9	5.6	-	
J _G 10 ⁻⁴ BSBF502	-	13	8.7	11	9.0	6.1	7.1	6.2	5.9	5.7	-	
J _G 10 ⁻⁴ BSHF502	-	12	8.6	11	8.9	6.0	7.0	6.2	5.9	5.6	-	
M _{NOTAUS}	-	330	485	530	560	520	560	560	560	560	-	
M _B	-	220	325	355	375	325	375	375	375	375	-	
η _K	-	200	66	50	130	58	133	130	128	133	-	
F _{Ra} (M _B)BSF502	-	11700	12200	12100	12000	12200	12000	12000	12000	12000	-	
F _{Ra} (M _B)BSBF502	-	14000	14400	14400	14400	14400	14400	14400	14400	14400	-	
F _{Ra} (M _B)BSHF502	-	12600	13700	14400	14400	14400	14400	14400	14400	14400	-	
M _N	-	145	215	235	250	260	250	250	250	250	-	
F _{Ra} (M _N)BSF502	-	12000	12400	12400	12300	12300	12300	12300	12300	12300	-	
F _{Ra} (M _N)BSBF502	-	14400	14400	14400	14400	14400	14400	14400	14400	14400	-	
F _{Ra} (M _N)BSHF502	-	13000	14400	14400	14400	14400	14400	14400	14400	14400	-	

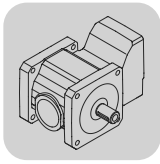
BSF..
BSF.. EBH.. [Nm]

$n_e = 1500 \text{ min}^{-1}$ BSF502EBH06 BSF502EBH07	iges										
	3	4	6	8	10	12	15	20	25	30	35
η	0.94	0.94	0.94	0.94	0.90	-	0.90	0.90	0.89	-	-
$J_G 10^{-4}$ BSF502	21	16	12	15	13	-	11	10	9.8	-	-
$J_G 10^{-4}$ BSBF502	22	17	13	15	13	-	11	10	9.8	-	-
$J_G 10^{-4}$ BSHF502	21	16	13	15	13	-	11	10	9.8	-	-
M_{NOTAUS}	470	600	640	640	560	-	560	560	560	-	-
M_B	315	400	410	420	375	-	375	375	375	-	-
n_K	200	100	116	100	130	-	133	130	128	-	-
$F_{Ra}(M_B)$ BSF502	9500	9540	11400	11900	12000	-	12000	12000	12000	-	-
$F_{Ra}(M_B)$ BSBF502	11600	11600	13800	14400	14400	-	14400	14400	14400	-	-
$F_{Ra}(M_B)$ BSHF502	10300	10300	12300	13900	14400	-	14400	14400	14400	-	-
M_N	210	270	320	320	250	-	250	250	250	-	-
$F_{Ra}(M_N)$ BSF502	10700	11400	12200	12200	12300	-	12300	12300	12300	-	-
$F_{Ra}(M_N)$ BSBF502	12800	13700	14400	14400	14400	-	14400	14400	14400	-	-
$F_{Ra}(M_N)$ BSHF502	11500	12300	13700	14400	14400	-	14400	14400	14400	-	-

$n_e = 1500 \text{ min}^{-1}$ BSF502EBH08	iges										
	3	4	6	8	10	12	15	20	25	30	35
η	0.94	0.94	0.94	0.94	0.90	-	0.90	0.89	-	-	-
$J_G 10^{-4}$ BSF502	31	26	23	25	23	-	21	20	-	-	-
$J_G 10^{-4}$ BSBF502	32	27	23	25	23	-	21	20	-	-	-
$J_G 10^{-4}$ BSHF502	32	27	23	25	23	-	21	20	-	-	-
M_{NOTAUS}	620	640	640	640	560	-	560	560	-	-	-
M_B	370	400	410	420	375	-	375	375	-	-	-
n_K	266	200	183	162	130	-	133	130	-	-	-
$F_{Ra}(M_B)$ BSF502	8720	9540	11400	11900	12000	-	12000	12000	-	-	-
$F_{Ra}(M_B)$ BSBF502	10600	11600	13800	14400	14400	-	14400	14400	-	-	-
$F_{Ra}(M_B)$ BSHF502	9450	10300	12300	13900	14400	-	14400	14400	-	-	-
M_N	310	320	320	320	250	-	250	250	-	-	-
$F_{Ra}(M_N)$ BSF502	9580	10700	12200	12200	12300	-	12300	12300	-	-	-
$F_{Ra}(M_N)$ BSBF502	11600	13000	14400	14400	14400	-	14400	14400	-	-	-
$F_{Ra}(M_N)$ BSHF502	10400	11600	13700	14400	14400	-	14400	14400	-	-	-

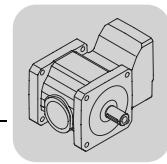

B..602 EBH..

	EBH															
	M _N [Nm]	M _B [Nm]	M _{NOTAUS} [Nm]	i	03		04		05		06		07		08	
					M _N [Nm]	M _B [Nm]	M _N [Nm]	M _B [Nm]	M _N [Nm]	M _B [Nm]	M _N [Nm]	M _B [Nm]	M _N [Nm]	M _B [Nm]	M _N [Nm]	M _B [Nm]
BSF602	520	750	1120	40.00*	425	640	425	640	520	750						
	520	750	1120	35.00*	395	595	395	595	520	750						
BSKF602	520	750	1120	30.00*	390	585	390	585	520	750	520	750	520	750		
	520	750	1120	25.00*	370	555	370	555	520	750	520	750	520	750	520	750
BSBF602	520	750	1120	20.00*	295	445	295	445	520	750	520	750	520	750	520	750
	520	750	1120	15.00*					520	750	520	750	520	750	520	750
BSHF602	550	775	1160	12.00*					305	460	445	510	445	510		
	520	750	1120	10.00*					350	525	520	750	520	750	520	750
	640	780	1280	8.00*							410	615	410	615	565	780
	610	800	1220	6.00*							380	570	380	570	525	790
	575	715	1150	4.00*							280	420	280	420	430	645
	505	700	1050	3.00*												350 525

m [kg]	EBH					
	03	04	05	06	07	08
BSF602 / BSKF602	47	47	49	52	52	56
BSBF602	47	47	50	52	52	56
BSHF602	44	44	46	49	49	53

n _e = 1500 min ⁻¹ BSF602EBH03 BSF602EBH04	iges											
	3	4	6	8	10	12	15	20	25	30	35	40
η	-	-	-	-	-	-	-	0.89	0.90	0.90	0.90	0.90
J _G 10 ⁻⁴ BSF602	-	-	-	-	-	-	-	4.5	3.5	2.8	2.4	2.1
J _G 10 ⁻⁴ BSBF602	-	-	-	-	-	-	-	4.6	3.5	2.8	2.4	2.1
J _G 10 ⁻⁴ BSHF602	-	-	-	-	-	-	-	4.6	3.5	2.8	2.4	2.1
M _{NOTAUS}	-	-	-	-	-	-	-	665	830	870	890	960
M _B	-	-	-	-	-	-	-	445	555	585	595	640
η _K	-	-	-	-	-	-	-	35	16	13	11	10
F _{Ra} (M _B)BSF602	-	-	-	-	-	-	-	24000	24000	24000	24000	24000
F _{Ra} (M _B)BSBF602	-	-	-	-	-	-	-	24000	24000	24000	24000	24000
F _{Ra} (M _B)BSHF602	-	-	-	-	-	-	-	24000	24000	24000	24000	24000
M _N	-	-	-	-	-	-	-	295	370	390	395	425
F _{Ra} (M _N)BSF602	-	-	-	-	-	-	-	24000	24000	24000	24000	24000
F _{Ra} (M _N)BSBF602	-	-	-	-	-	-	-	24000	24000	24000	24000	24000
F _{Ra} (M _N)BSHF602	-	-	-	-	-	-	-	24000	24000	24000	24000	24000

n _e = 1500 min ⁻¹ BSF602EBH05	iges											
	3	4	6	8	10	12	15	20	25	30	35	40
η	-	-	-	-	0.90	0.93	0.91	0.91	0.90	0.90	0.90	0.90
J _G 10 ⁻⁴ BSF602	-	-	-	-	15	7.9	10	8.4	7.4	6.7	6.3	6.0
J _G 10 ⁻⁴ BSBF602	-	-	-	-	15	8.0	10	8.5	7.4	6.7	6.3	6.0
J _G 10 ⁻⁴ BSHF602	-	-	-	-	15	8.0	10	8.5	7.4	6.7	6.3	6.0
M _{NOTAUS}	-	-	-	-	785	690	1120	1120	1120	1120	1120	1120
M _B	-	-	-	-	525	460	750	750	750	750	750	750
η _K	-	-	-	-	140	33	53	55	52	46	42	47
F _{Ra} (M _B)BSF602	-	-	-	-	22400	24000	24000	24000	24000	24000	24000	24000
F _{Ra} (M _B)BSBF602	-	-	-	-	24000	24000	24000	24000	24000	24000	24000	24000
F _{Ra} (M _B)BSHF602	-	-	-	-	23100	24000	24000	24000	24000	24000	24000	24000
M _N	-	-	-	-	350	305	520	520	520	520	520	520
F _{Ra} (M _N)BSF602	-	-	-	-	23400	24000	24000	24000	24000	24000	24000	24000
F _{Ra} (M _N)BSBF602	-	-	-	-	24000	24000	24000	24000	24000	24000	24000	24000
F _{Ra} (M _N)BSHF602	-	-	-	-	24000	24000	24000	24000	24000	24000	24000	24000

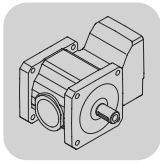
BSF..
BSF.. EBH.. [Nm]

$n_e = 1500 \text{ min}^{-1}$ BSF602EBH06 BSF602EBH07	iges											
	3	4	6	8	10	12	15	20	25	30	35	40
η	-	0.93	0.94	0.94	0.91	0.94	0.91	0.90	0.90	0.90	-	-
$J_G 10^{-4}$ BSF602	-	30	19	15	19	12	14	12	11	11	-	-
$J_G 10^{-4}$ BSBF602	-	31	20	15	19	12	14	12	11	11	-	-
$J_G 10^{-4}$ BSHF602	-	31	19	15	19	12	14	12	11	11	-	-
M_{NOTAUS}	-	630	850	920	1120	890	1120	1120	1120	1120	-	-
M_B	-	420	570	615	750	510	750	750	750	750	-	-
η_K	-	150	66	50	50	83	53	55	56	56	-	-
$F_{Ra}(M_B)$ BSF602	-	17400	19200	21000	21100	24000	24000	24000	24000	24000	-	-
$F_{Ra}(M_B)$ BSBF602	-	19900	22000	24000	24000	24000	24000	24000	24000	24000	-	-
$F_{Ra}(M_B)$ BSHF602	-	17900	19800	21600	21800	24000	24000	24000	24000	24000	-	-
M_N	-	280	380	410	520	445	520	520	520	520	-	-
$F_{Ra}(M_N)$ BSF602	-	18000	20100	21900	22400	24000	24000	24000	24000	24000	-	-
$F_{Ra}(M_N)$ BSBF602	-	20600	23000	24000	24000	24000	24000	24000	24000	24000	-	-
$F_{Ra}(M_N)$ BSHF602	-	18600	20700	22600	23100	24000	24000	24000	24000	24000	-	-

$n_e = 1500 \text{ min}^{-1}$ BSF602EBH08	iges											
	3	4	6	8	10	12	15	20	25	30	35	40
η	0.94	0.94	0.94	0.94	0.91	-	0.90	0.90	0.90	-	-	-
$J_G 10^{-4}$ BSF602	54	40	29	25	29	-	24	23	22	-	-	-
$J_G 10^{-4}$ BSBF602	56	41	30	26	29	-	25	23	22	-	-	-
$J_G 10^{-4}$ BSHF602	56	41	30	26	29	-	24	23	22	-	-	-
M_{NOTAUS}	785	960	1180	1170	1120	-	1120	1120	1120	-	-	-
M_B	525	645	790	780	750	-	750	750	750	-	-	-
η_K	166	100	66	62	50	-	53	55	56	-	-	-
$F_{Ra}(M_B)$ BSF602	15300	16000	17300	19800	21100	-	24000	24000	24000	-	-	-
$F_{Ra}(M_B)$ BSBF602	17500	18400	20000	22900	24000	-	24000	24000	24000	-	-	-
$F_{Ra}(M_B)$ BSHF602	15800	16500	17900	20500	21800	-	24000	24000	24000	-	-	-
M_N	350	430	525	565	520	-	520	520	520	-	-	-
$F_{Ra}(M_N)$ BSF602	16100	17300	19400	21200	22400	-	24000	24000	24000	-	-	-
$F_{Ra}(M_N)$ BSBF602	18400	19800	22200	24000	24000	-	24000	24000	24000	-	-	-
$F_{Ra}(M_N)$ BSHF602	16600	17900	20000	21900	23100	-	24000	24000	24000	-	-	-

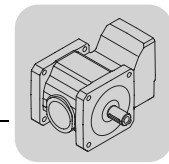

B..802 EBH..

	EBH															
	M _N [Nm]	M _B [Nm]	M _{NOTAUS} [Nm]	i	05		06		07		08		09		10	
					M _N [Nm]	M _B [Nm]	M _N [Nm]	M _B [Nm]	M _N [Nm]	M _B [Nm]	M _N [Nm]	M _B [Nm]	M _N [Nm]	M _B [Nm]	M _N [Nm]	M _B [Nm]
BSF802	1220	1680	2520	40.00*	990	1490	1220	1680	1220	1680	1220	1680				
	1220	1680	2520	35.00*	960	1440	1220	1680	1220	1680	1220	1680				
BSKF802	1220	1680	2520	30.00*	950	1430	1220	1680	1220	1680	1220	1680				
	1220	1680	2520	25.00*	880	1320	1220	1680	1220	1680	1220	1680				
BSBF802	1220	1680	2520	20.00*	700	1050	1220	1680	1220	1680	1220	1680	1220	1680	1220	1680
	1220	1680	2520	15.00*			1020	1530	1020	1530	1220	1680	1220	1680	1220	1680
BSHF802	1360	1910	2860	12.00*							800	1160				
	1220	1680	2520	10.00*							1130	1680	1220	1680	1220	1680
	1500	1910	3000	8.00*							710	1070	1110	1670	1110	1670
	1370	1910	2860	6.00*							660	990	950	1430	1120	1680
	1240	1860	2790	4.00*									635	950	870	1310

m [kg]	EBH					
	05	06	07	08	09	10
BSF802 / BSKF802	77	80	80	84	94	96
BSBF802	79	81	81	85	95	97
BSHF802	74	76	76	80	91	92

n _e = 1500 min ⁻¹ BSF802EBH05	iges											
	4	6	8	10	12	15	20	25	30	35	40	
η	-	-	-	-	-	-	0.90	0.90	0.91	0.91	0.91	
J _G 10 ⁻⁴ BSF802	-	-	-	-	-	-	17	13	11	10	9.2	
J _G 10 ⁻⁴ BSBF802	-	-	-	-	-	-	17	14	12	10	9.2	
J _G 10 ⁻⁴ BSHF802	-	-	-	-	-	-	17	14	12	10	9.3	
M _{NOTAUS}	-	-	-	-	-	-	1570	1980	2140	2160	2230	
M _B	-	-	-	-	-	-	1050	1320	1430	1440	1490	
η _K	-	-	-	-	-	-	35	20	13	11	10	
F _{Ra} (M _B)BSF802	-	-	-	-	-	-	36000	36000	36000	36000	36000	
F _{Ra} (M _B)BSBF802	-	-	-	-	-	-	36000	36000	36000	36000	36000	
F _{Ra} (M _B)BSHF802	-	-	-	-	-	-	36000	36000	36000	36000	36000	
M _N	-	-	-	-	-	-	700	880	950	960	990	
F _{Ra} (M _N)BSF802	-	-	-	-	-	-	36000	36000	36000	36000	36000	
F _{Ra} (M _N)BSBF802	-	-	-	-	-	-	36000	36000	36000	36000	36000	
F _{Ra} (M _N)BSHF802	-	-	-	-	-	-	36000	36000	36000	36000	36000	

n _e = 1500 min ⁻¹ BSF802EBH06 BSF802EBH07	iges											
	4	6	8	10	12	15	20	25	30	35	40	
η	-	-	-	-	-	0.91	0.91	0.91	0.91	0.91	0.91	
J _G 10 ⁻⁴ BSF802	-	-	-	-	-	27	21	17	15	14	13	
J _G 10 ⁻⁴ BSBF802	-	-	-	-	-	27	21	18	16	14	13	
J _G 10 ⁻⁴ BSHF802	-	-	-	-	-	27	21	18	16	14	13	
M _{NOTAUS}	-	-	-	-	-	2290	2520	2520	2520	2520	2520	
M _B	-	-	-	-	-	1530	1680	1680	1680	1680	1680	
η _K	-	-	-	-	-	40	30	32	30	25	25	
F _{Ra} (M _B)BSF802	-	-	-	-	-	36000	36000	36000	36000	36000	36000	
F _{Ra} (M _B)BSBF802	-	-	-	-	-	36000	36000	36000	36000	36000	36000	
F _{Ra} (M _B)BSHF802	-	-	-	-	-	36000	36000	36000	36000	36000	36000	
M _N	-	-	-	-	-	1020	1220	1220	1220	1220	1220	
F _{Ra} (M _N)BSF802	-	-	-	-	-	36000	36000	36000	36000	36000	36000	
F _{Ra} (M _N)BSBF802	-	-	-	-	-	36000	36000	36000	36000	36000	36000	
F _{Ra} (M _N)BSHF802	-	-	-	-	-	36000	36000	36000	36000	36000	36000	

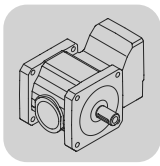
BSF..
BSF.. EBH.. [Nm]

$n_e = 1500 \text{ min}^{-1}$ BSF802EBH08	iges										
	4	6	8	10	12	15	20	25	30	35	40
η	-	0.93	0.93	0.91	0.94	0.91	0.91	0.91	0.91	0.91	0.91
$J_G 10^{-4}$ BSF802	-	54	40	51	30	37	31	28	26	24	23
$J_G 10^{-4}$ BSBF802	-	57	42	52	31	37	31	28	26	24	23
$J_G 10^{-4}$ BSHF802	-	59	43	53	31	38	31	28	26	24	23
M_{NOTAUS}	-	1480	1600	2520	1740	2520	2520	2520	2520	2520	2520
M_B	-	990	1070	1680	1160	1680	1680	1680	1680	1680	1680
n_K	-	66	50	60	41	60	65	60	60	65	65
$F_{Ra}(M_B)$ BSF802	-	35000	36000	36000	36000	36000	36000	36000	36000	36000	36000
$F_{Ra}(M_B)$ BSBF802	-	36000	36000	36000	36000	36000	36000	36000	36000	36000	36000
$F_{Ra}(M_B)$ BSHF802	-	34900	36000	36000	36000	36000	36000	36000	36000	36000	36000
M_N	-	660	710	1130	800	1220	1220	1220	1220	1220	1220
$F_{Ra}(M_N)$ BSF802	-	36000	36000	36000	36000	36000	36000	36000	36000	36000	36000
$F_{Ra}(M_N)$ BSBF802	-	36000	36000	36000	36000	36000	36000	36000	36000	36000	36000
$F_{Ra}(M_N)$ BSHF802	-	36000	36000	36000	36000	36000	36000	36000	36000	36000	36000

$n_e = 1500 \text{ min}^{-1}$ BSF802EBH09	iges										
	4	6	8	10	12	15	20	25	30	35	40
η	0.93	0.94	0.94	0.91	-	0.91	0.91	-	-	-	-
$J_G 10^{-4}$ BSF802	126	91	77	88	-	74	68	-	-	-	-
$J_G 10^{-4}$ BSBF802	134	94	79	89	-	74	68	-	-	-	-
$J_G 10^{-4}$ BSHF802	138	96	80	90	-	75	68	-	-	-	-
M_{NOTAUS}	1420	2140	2500	2520	-	2520	2520	-	-	-	-
M_B	950	1430	1670	1680	-	1680	1680	-	-	-	-
n_K	350	116	62	60	-	60	65	-	-	-	-
$F_{Ra}(M_B)$ BSF802	30800	33600	35700	36000	-	36000	36000	-	-	-	-
$F_{Ra}(M_B)$ BSBF802	36000	36000	36000	36000	-	36000	36000	-	-	-	-
$F_{Ra}(M_B)$ BSHF802	30700	33500	35600	36000	-	36000	36000	-	-	-	-
M_N	635	950	1110	1220	-	1220	1220	-	-	-	-
$F_{Ra}(M_N)$ BSF802	31800	35100	36000	36000	-	36000	36000	-	-	-	-
$F_{Ra}(M_N)$ BSBF802	36000	36000	36000	36000	-	36000	36000	-	-	-	-
$F_{Ra}(M_N)$ BSHF802	31700	35100	36000	36000	-	36000	36000	-	-	-	-

$n_e = 1500 \text{ min}^{-1}$ BSF802EBH10	iges										
	4	6	8	10	12	15	20	25	30	35	40
η	0.94	0.94	0.94	0.91	-	0.91	0.91	-	-	-	-
$J_G 10^{-4}$ BSF802	149	114	100	111	-	97	91	-	-	-	-
$J_G 10^{-4}$ BSBF802	157	117	102	113	-	98	91	-	-	-	-
$J_G 10^{-4}$ BSHF802	161	119	103	113	-	98	91	-	-	-	-
M_{NOTAUS}	1960	2520	2500	2520	-	2520	2520	-	-	-	-
M_B	1310	1680	1670	1680	-	1680	1680	-	-	-	-
n_K	125	66	62	60	-	60	65	-	-	-	-
$F_{Ra}(M_B)$ BSF802	29400	31400	35700	36000	-	36000	36000	-	-	-	-
$F_{Ra}(M_B)$ BSBF802	34700	36000	36000	36000	-	36000	36000	-	-	-	-
$F_{Ra}(M_B)$ BSHF802	29300	31300	35600	36000	-	36000	36000	-	-	-	-
M_N	870	1120	1110	1220	-	1220	1220	-	-	-	-
$F_{Ra}(M_N)$ BSF802	31000	34600	36000	36000	-	36000	36000	-	-	-	-
$F_{Ra}(M_N)$ BSBF802	36000	36000	36000	36000	-	36000	36000	-	-	-	-
$F_{Ra}(M_N)$ BSHF802	31000	34500	36000	36000	-	36000	36000	-	-	-	-

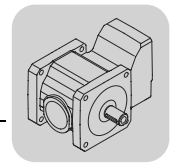

7.5 BS.. DS../CM.. [mm]

BSF202..

56 001 00 03

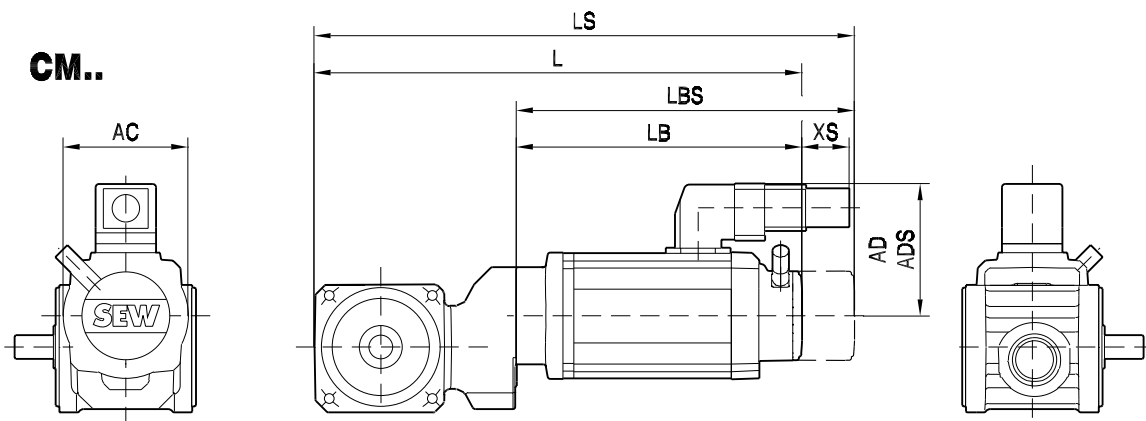
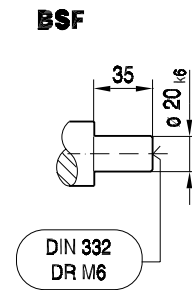
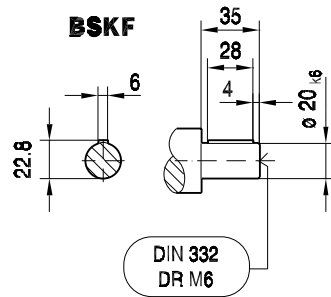
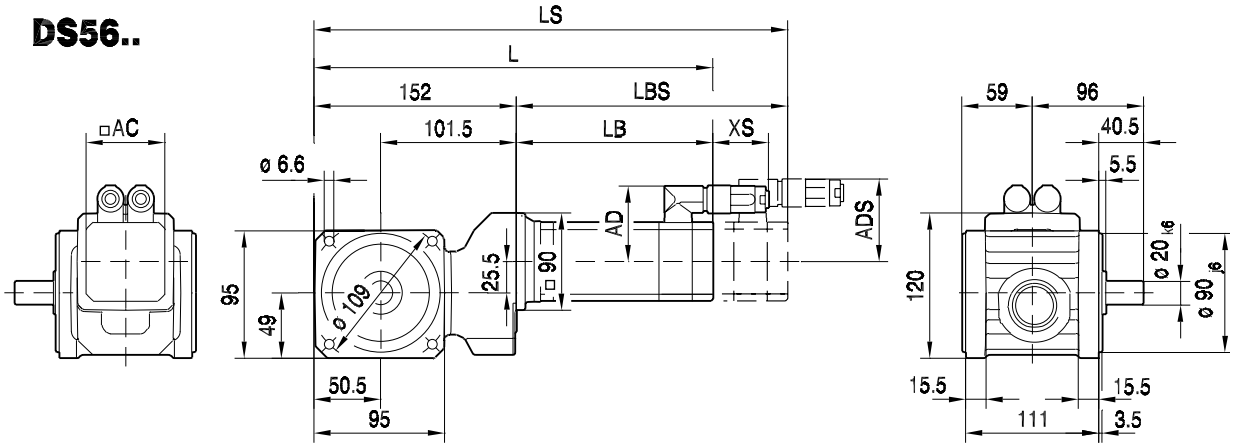

(→ 90)	DFS56M	DFS56L	DFS56H							
AC	73	73	73							
AD	71	71	77							
ADS	77	77	77							
L	290	322	425							
LS	320	352	425							
LB	139	171	274							
LBS	169	201	274							
XS	70	70	51							

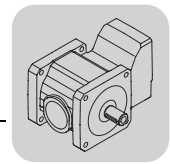

BSHF202..

56 044 00 03

DS56..

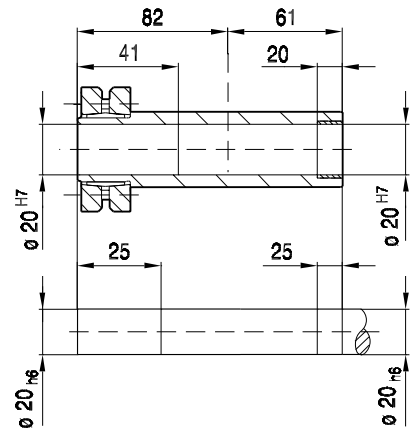
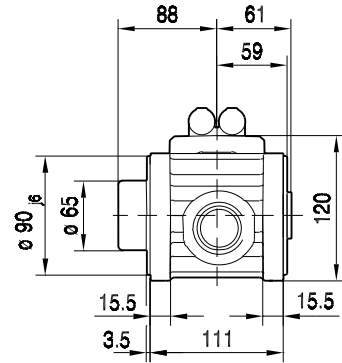
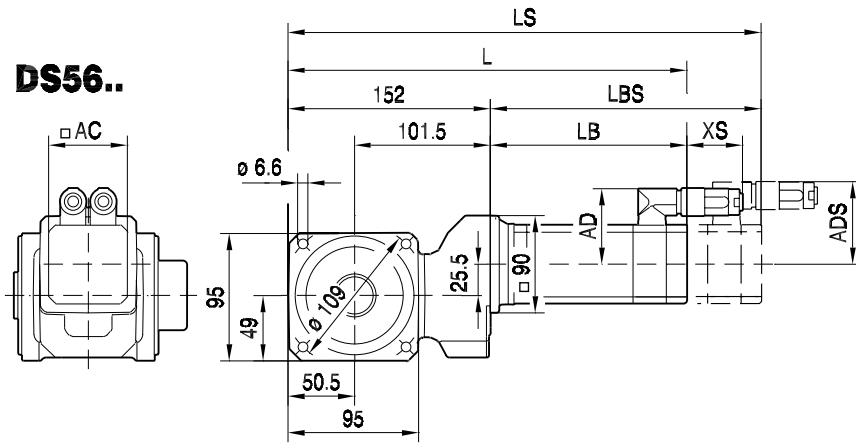

CM..

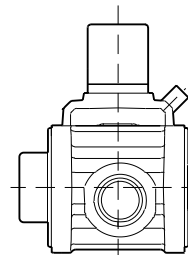
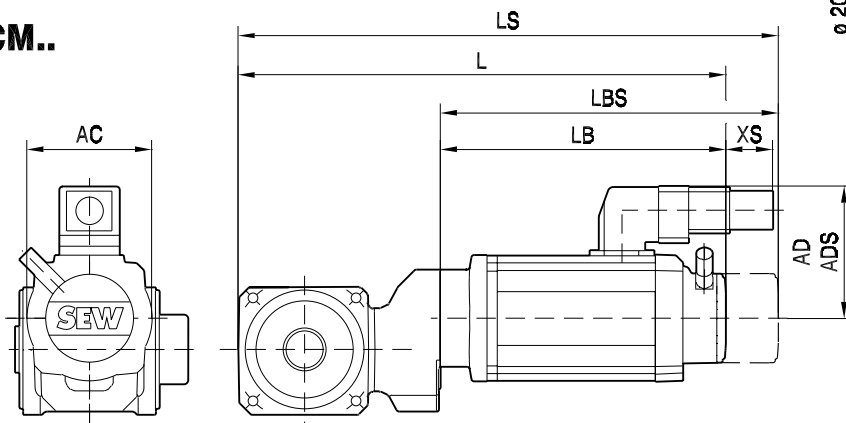

7

(→ 90)	DFS56M	DFS56L	DFS56H							
AC	73	73	73							
AD	71	71	77							
ADS	77	77	77							
L	290	322	425							
LS	320	352	425							
LB	139	171	274							
LBS	169	201	274							
XS	70	70	51							

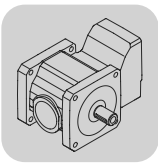

BSHF202/I..

56 003 00 03

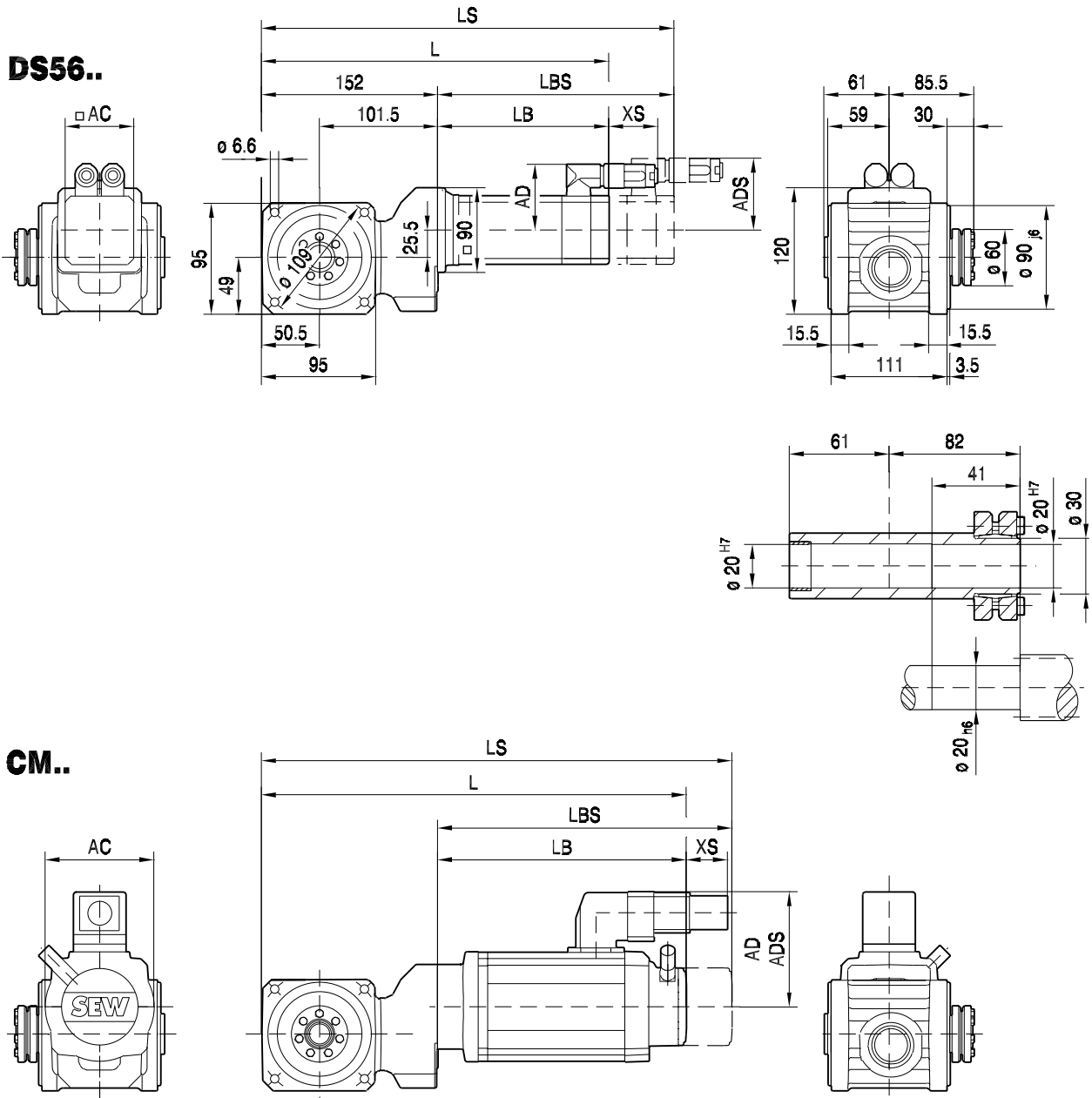

(→ 90)	DFS56M	DFS56L	DFS56H							
AC	73	73	73							
AD	71	71	77							
ADS	77	77	77							
L	290	322	425							
LS	320	352	425							
LB	139	171	274							
LBS	169	201	274							
XS	70	70	51							

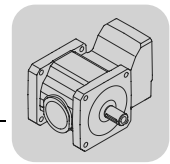

BSF302..

56 004 00 03

DS56..

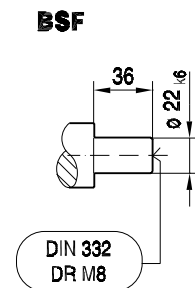
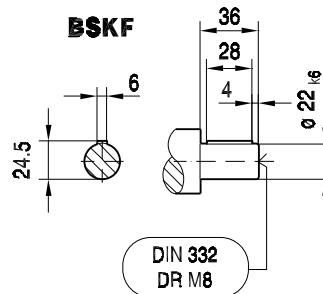
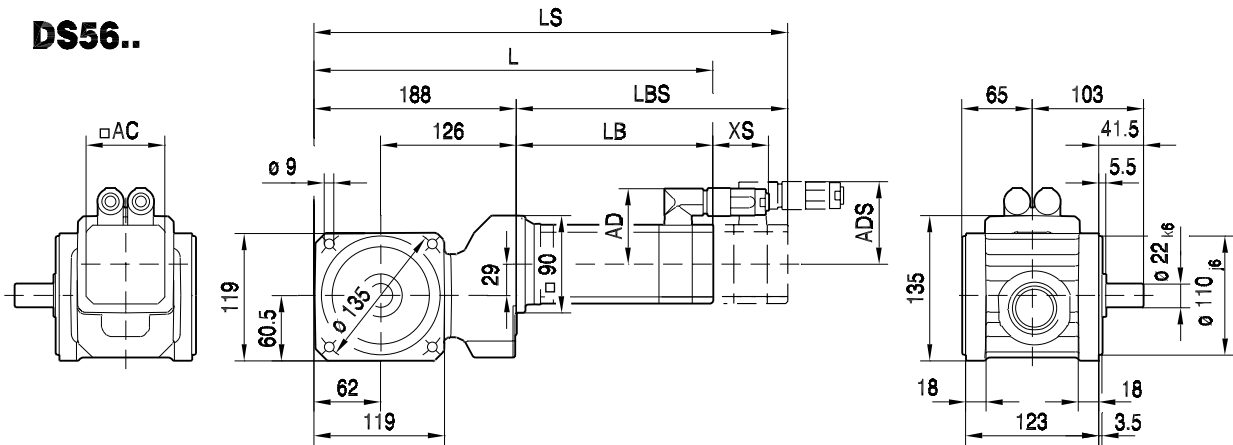

CM..

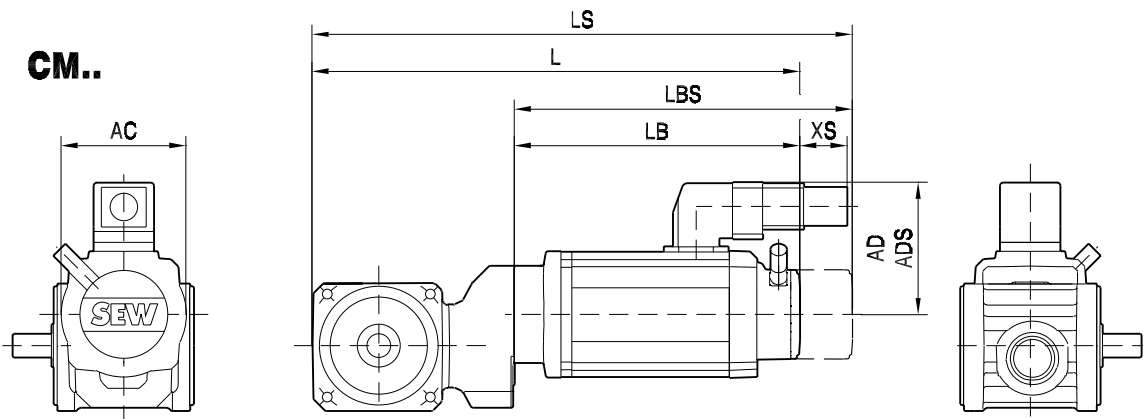

(→ 90)	DFS56M	DFS56L	DFS56H	CFM71S	CFM71M					
AC	73	73	73	117	117					
AD	71	71	77	122	122					
ADS	77	77	77	122	122					
L	326	358	461	427	447					
LS	356	388	461	509	529					
LB	139	171	274	239	259					
LBS	169	201	274	321	341					
XS	70	70	51	45	45					

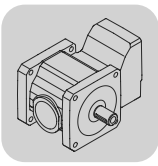

BSBF302..

56 005 00 03

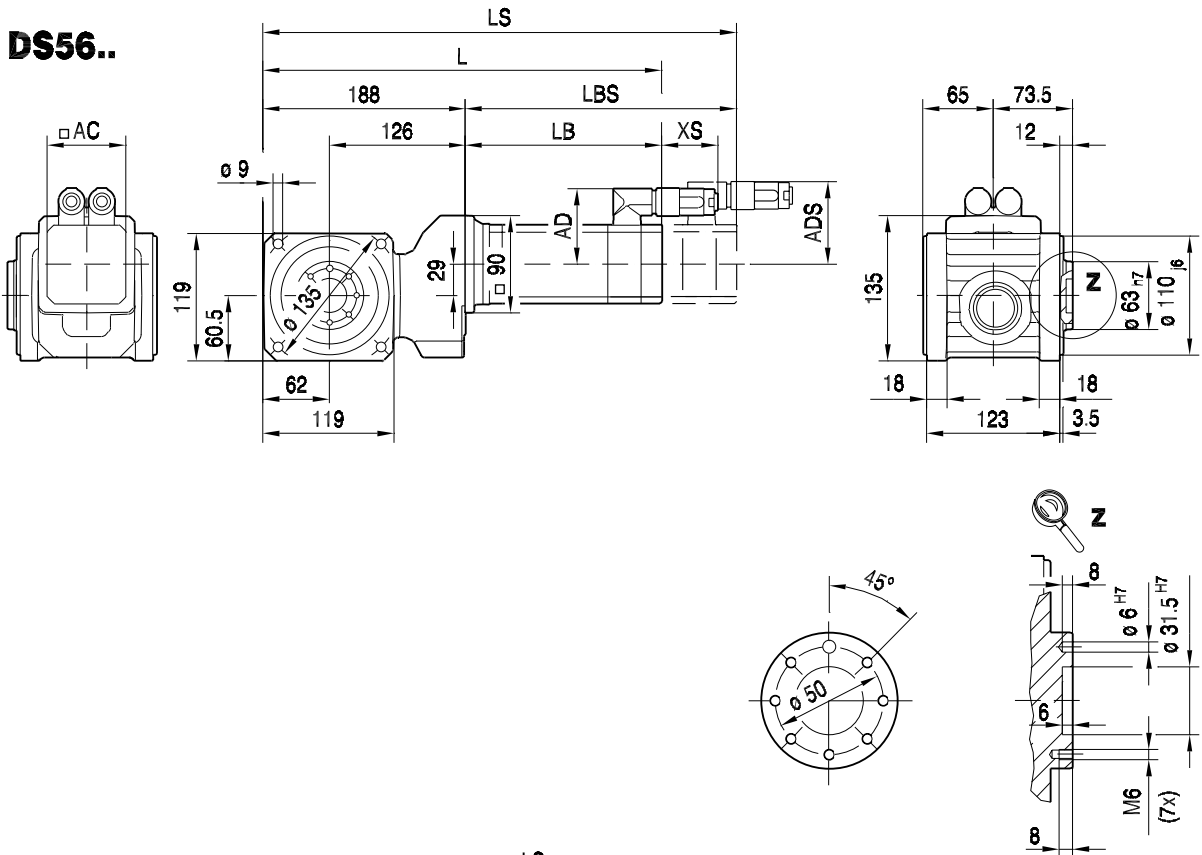

(→ 90)	DFS56M	DFS56L	DFS56H	CFM71S	CFM71M					
AC	73	73	73	117	117					
AD	71	71	77	122	122					
ADS	77	77	77	122	122					
L	326	358	461	427	447					
LS	356	388	461	509	529					
LB	139	171	274	239	259					
LBS	169	201	274	321	341					
XS	70	70	51	45	45					

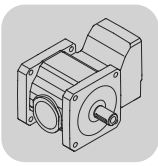

BSHF302/I..

56 006 00 03

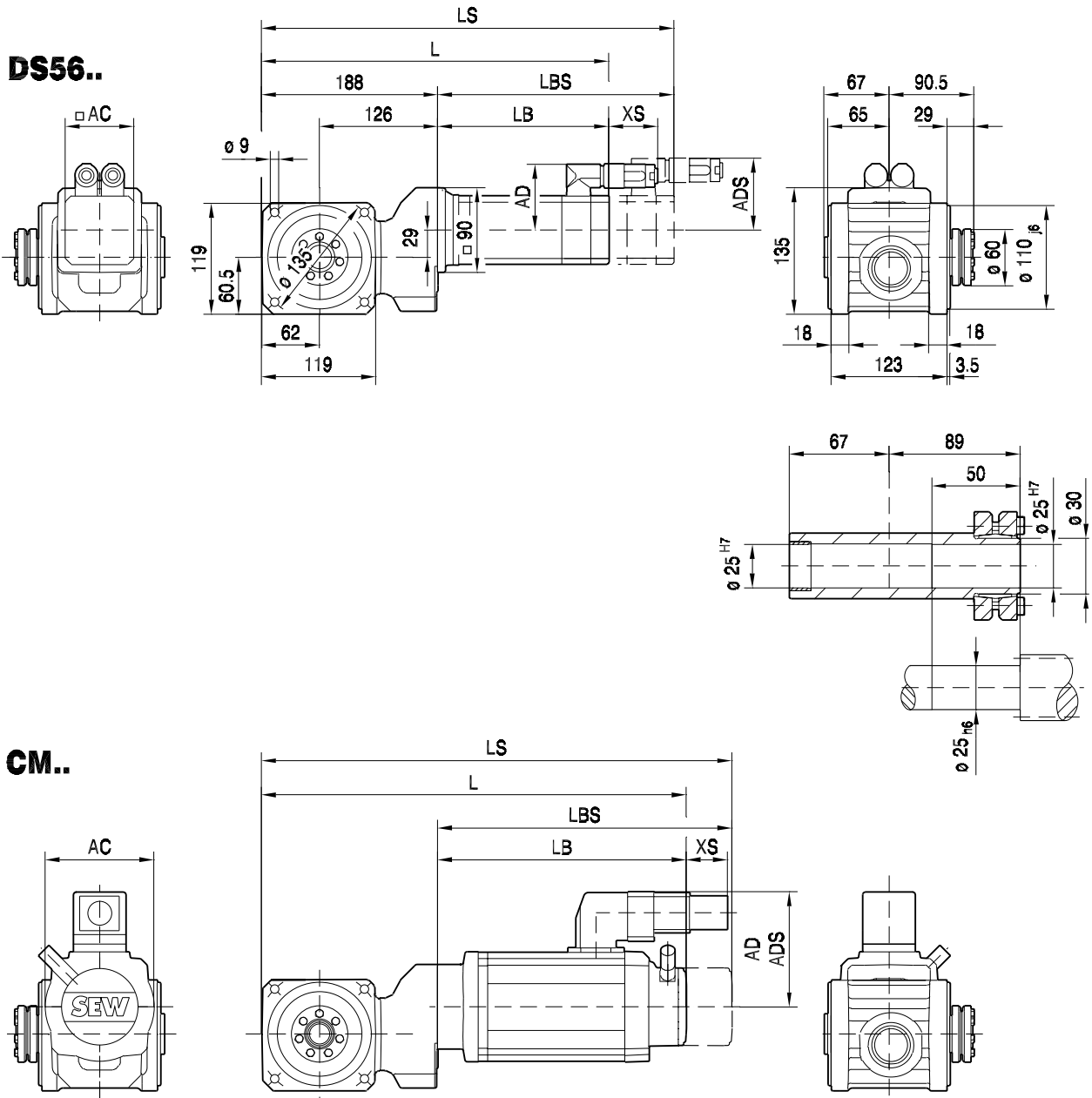

(→ 90)	DFS56M	DFS56L	DFS56H	CFM71S	CFM71M					
AC	73	73	73	117	117					
AD	71	71	77	122	122					
ADS	77	77	77	122	122					
L	326	358	461	427	447					
LS	356	388	461	509	529					
LB	139	171	274	239	259					
LBS	169	201	274	321	341					
XS	70	70	51	45	45					

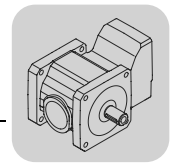

BSF402..

56 007 00 03

DS56..

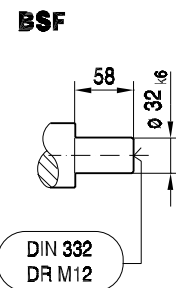
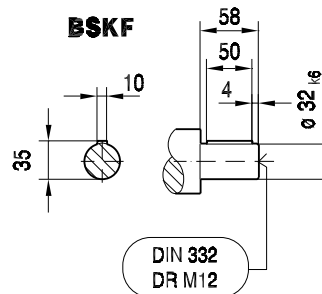
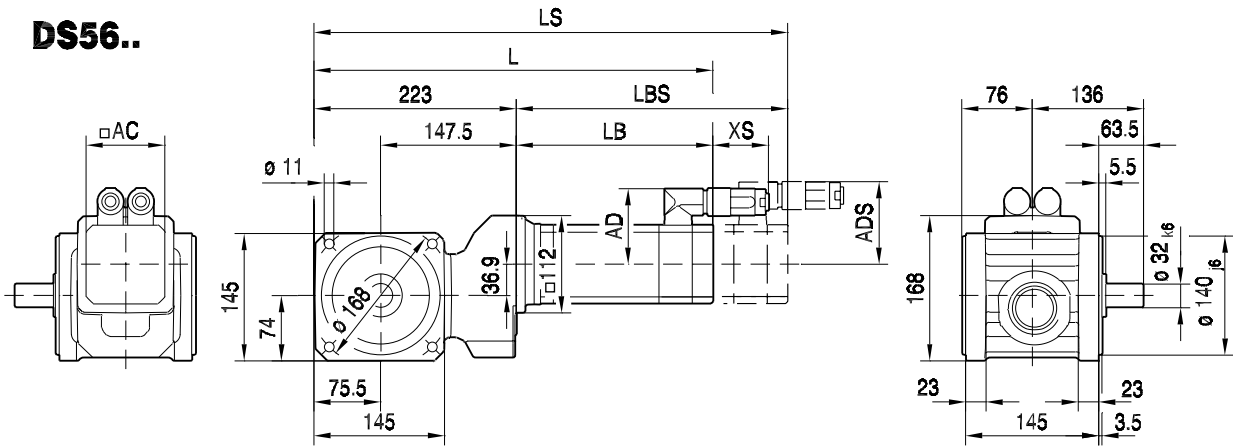

CM..

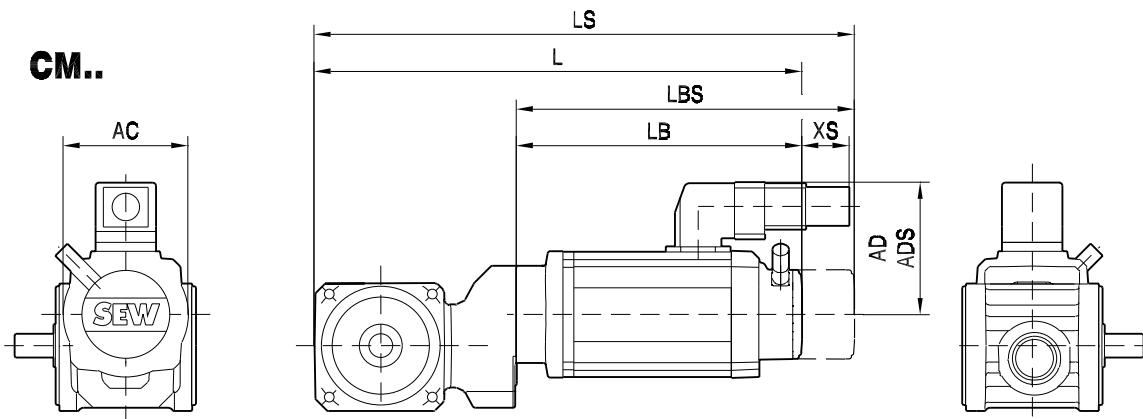

(→ 90)	DFS56H	CFM71S	CFM71M	CFM71L	CFM90S	CFM90M	CFM90L			
AC	73	117	117	117	142	142	142			
AD	77	122	122	122	140	140	140			
ADS	77	122	122	122	140	140	140			
L	491	457	477	517	509	536	590			
LS	491	539	559	599	604	631	685			
LB	269	234	254	294	286	313	367			
LBS	269	316	336	376	382	409	463			
XS	51	45	45	45	50	50	50			

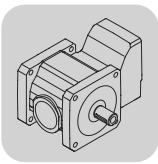

BSBF402..

56 008 00 03

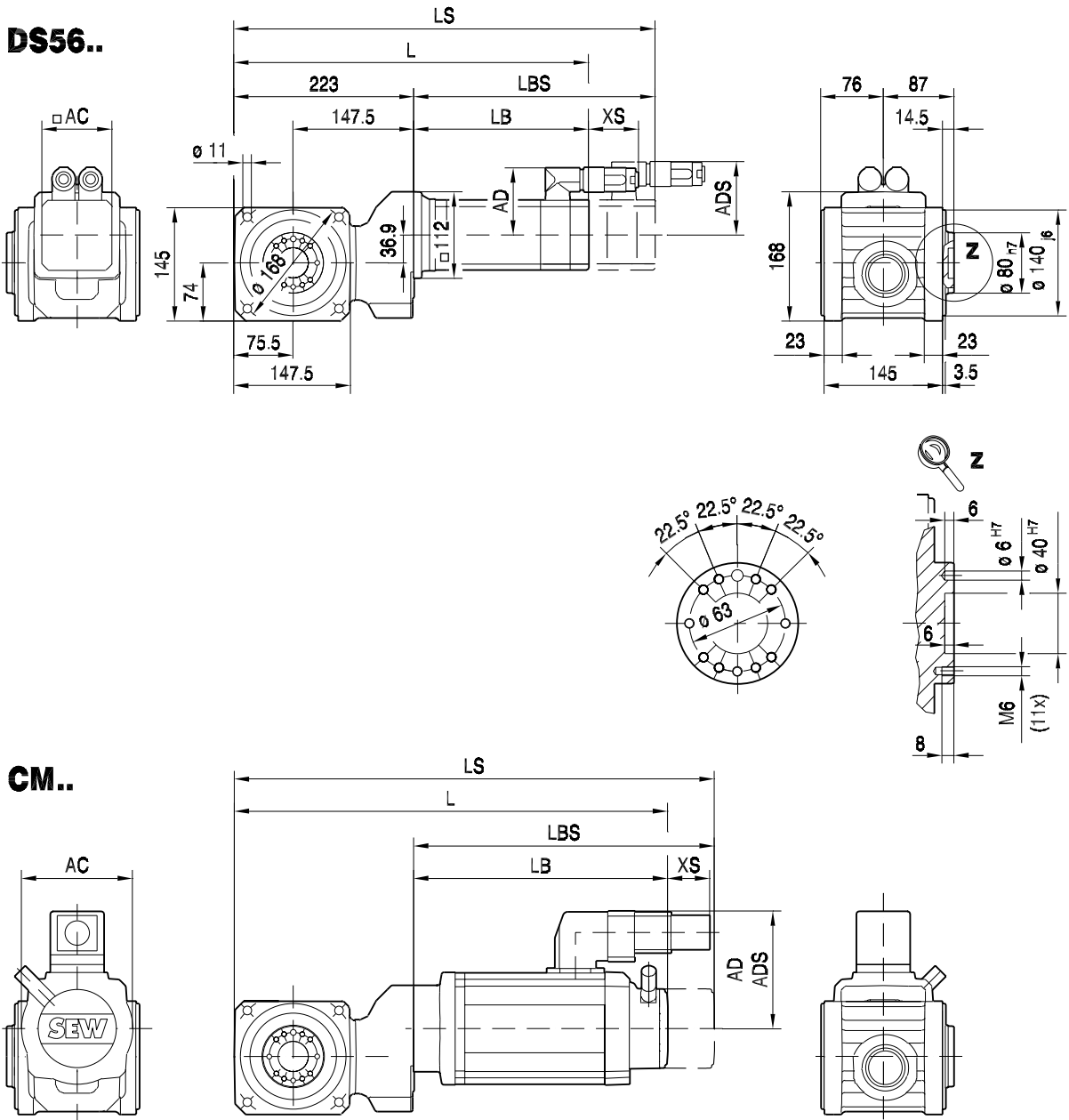

(→ 90)	DFS56H	CFM71S	CFM71M	CFM71L	CFM90S	CFM90M	CFM90L			
AC	73	117	117	117	142	142	142			
AD	77	122	122	122	140	140	140			
ADS	77	122	122	122	140	140	140			
L	491	457	477	517	509	536	590			
LS	491	539	559	599	604	631	685			
LB	269	234	254	294	286	313	367			
LBS	269	316	336	376	382	409	463			
XS	51	45	45	45	50	50	50			

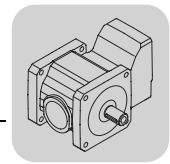

BSHF402..

56 048 00 03

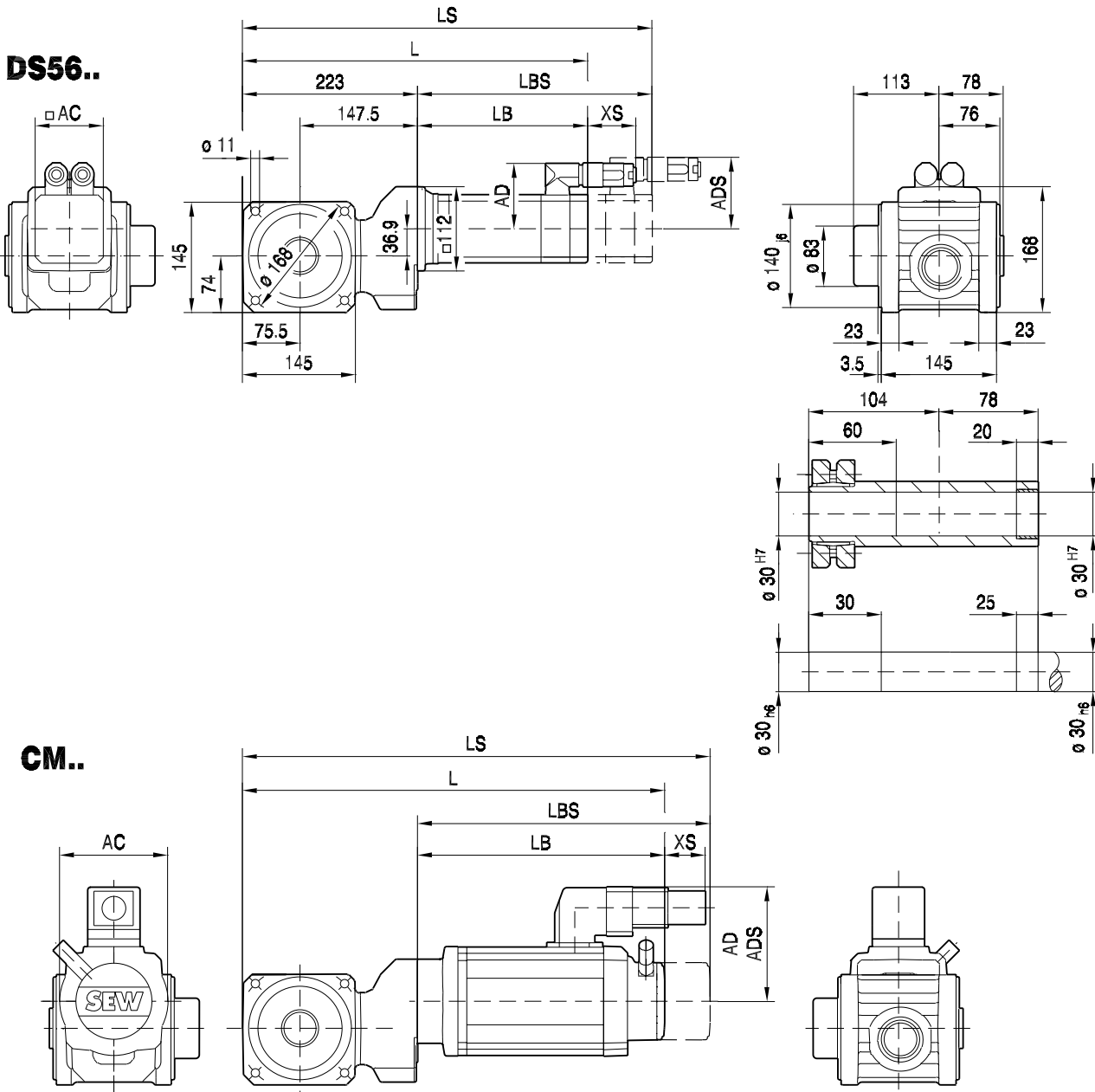

7

(→ 90)	DFS56H	CFM71S	CFM71M	CFM71L	CFM90S	CFM90M	CFM90L			
AC	73	117	117	117	142	142	142			
AD	77	122	122	122	140	140	140			
ADS	77	122	122	122	140	140	140			
L	491	457	477	517	509	536	590			
LS	491	539	559	599	604	631	685			
LB	269	234	254	294	286	313	367			
LBS	269	316	336	376	382	409	463			
XS	51	45	45	45	50	50	50			

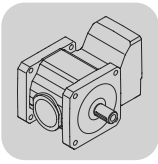
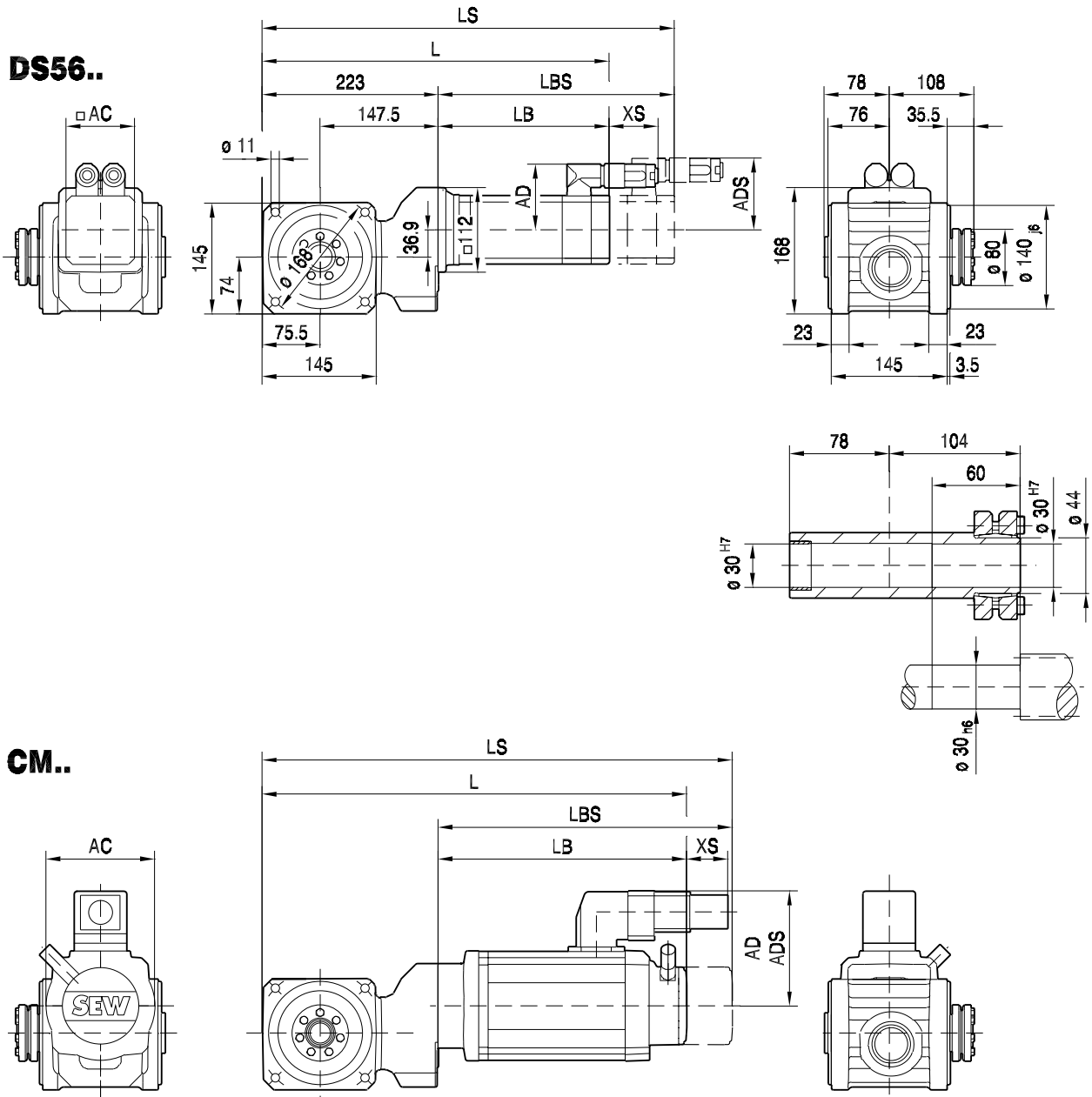
BSHF402/I..
56 009 00 03

(→ 90)	DFS56H	CFM71S	CFM71M	CFM71L	CFM90S	CFM90M	CFM90L			
AC	73	117	117	117	142	142	142			
AD	77	122	122	122	140	140	140			
ADS	77	122	122	122	140	140	140			
L	491	457	477	517	509	536	590			
LS	491	539	559	599	604	631	685			
LB	269	234	254	294	286	313	367			
LBS	269	316	336	376	382	409	463			
XS	51	45	45	45	50	50	50			

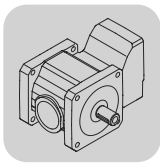
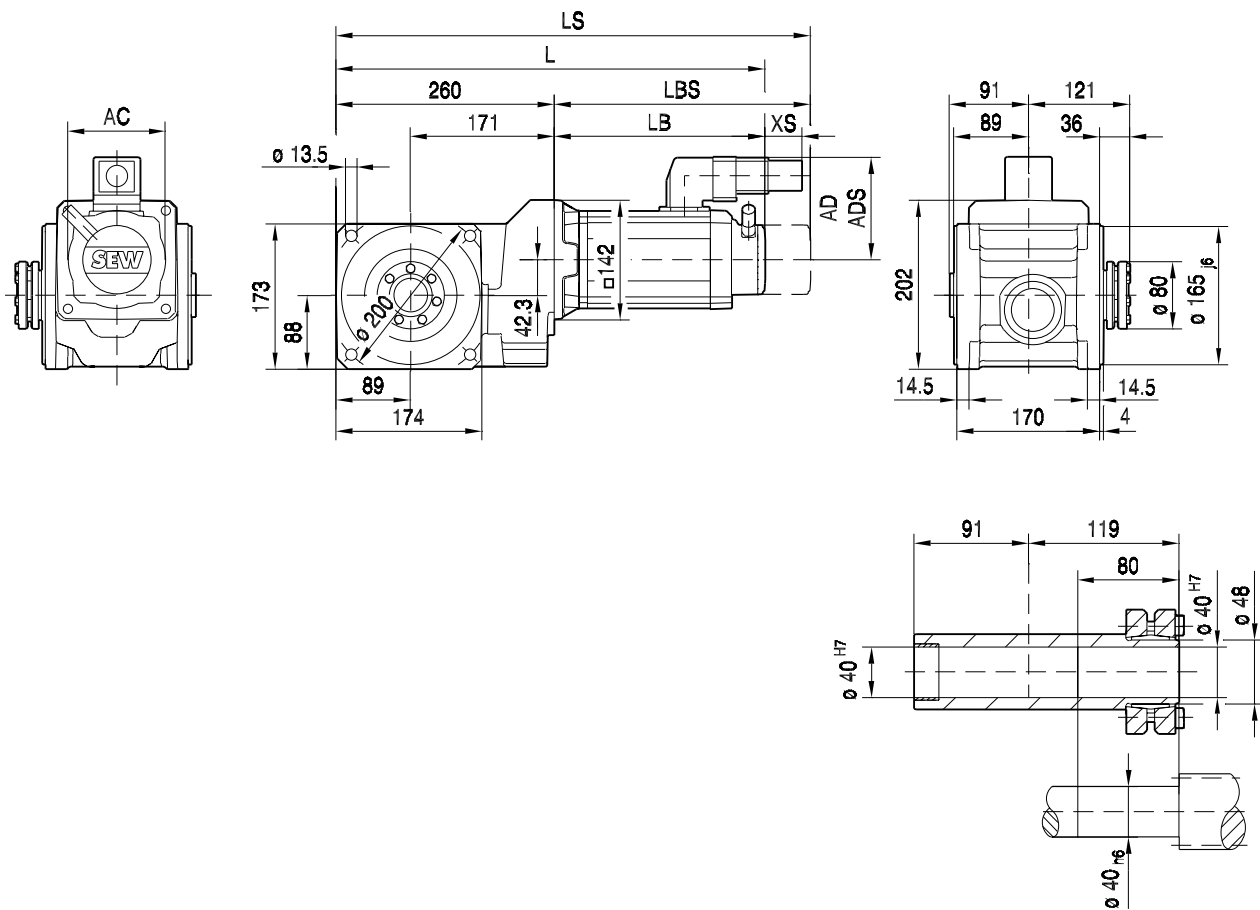
BSHF502/I..
56 012 00 03

(→ 90)	CFM71S	CFM71M	CFM71L	CFM90S	CFM90M	CFM90L	CFM112S			
AC	117	117	117	142	142	142	186			
AD	122	122	122	140	140	140	165			
ADS	122	122	122	140	140	140	165			
L	486	506	546	538	565	619	573			
LS	568	588	628	634	661	715	663			
LB	226	246	286	278	305	359	313			
LBS	308	328	368	374	401	455	403			
XS	45	45	45	50	50	50	36			

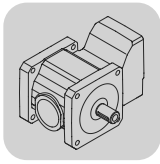
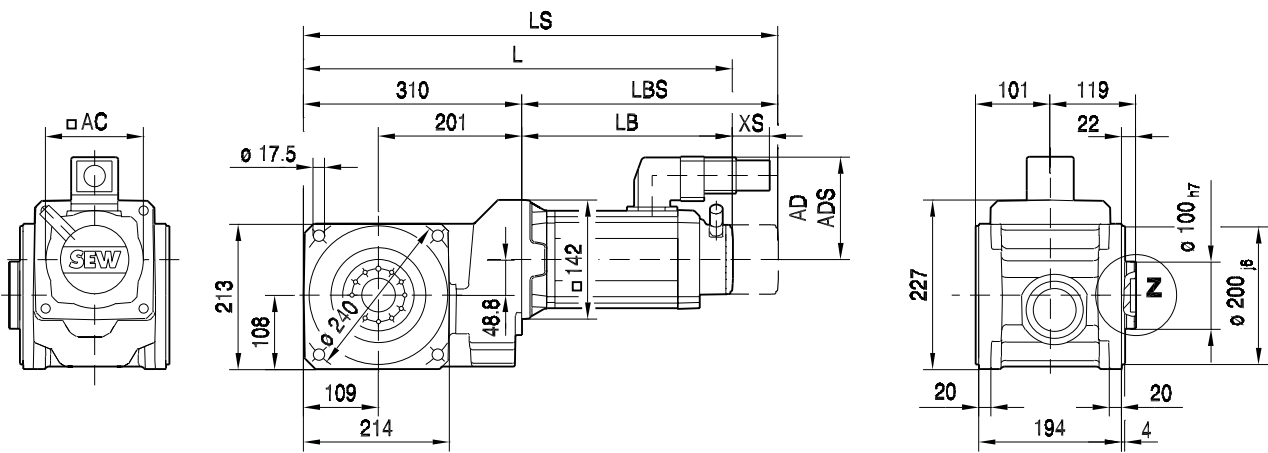

BSBF602..
56 014 00 03

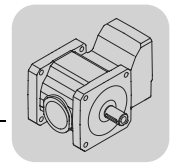
(→ 90)	CFM71S	CFM71M	CFM71L	CFM90S	CFM90M	CFM90L	CFM112S	CFM112M	CFM112L		
AC	117	117	117	142	142	142	186	186	186		
AD	122	122	122	140	140	140	165	165	165		
ADS	122	122	122	140	140	140	165	165	165		
L	536	556	596	588	615	669	623	650	707		
LS	618	638	678	684	711	765	713	740	797		
LB	226	246	286	278	305	359	313	340	397		
LBS	308	328	368	374	401	455	403	430	487		
XS	45	45	45	50	50	50	36	36	36		

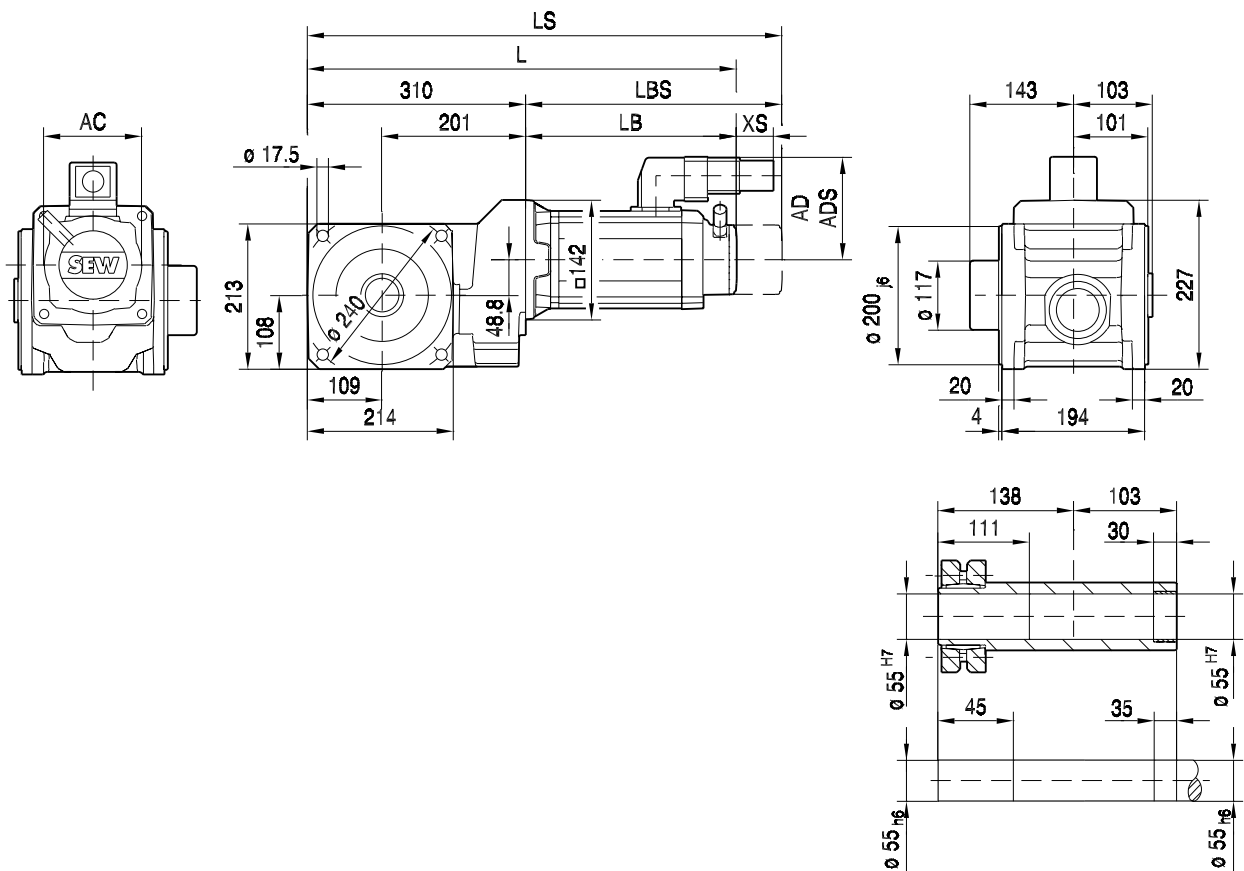

BSHF602..

56 052 00 03



(→ 90)	CFM71S	CFM71M	CFM71L	CFM90S	CFM90M	CFM90L	CFM112S	CFM112M	CFM112L		
AC	117	117	117	142	142	142	186	186	186		
AD	122	122	122	140	140	140	165	165	165		
ADS	122	122	122	140	140	140	165	165	165		
L	536	556	596	588	615	669	623	650	707		
LS	618	638	678	684	711	765	713	740	797		
LB	226	246	286	278	305	359	313	340	397		
LBS	308	328	368	374	401	455	403	430	487		
XS	45	45	45	50	50	50	36	36	36		

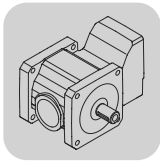
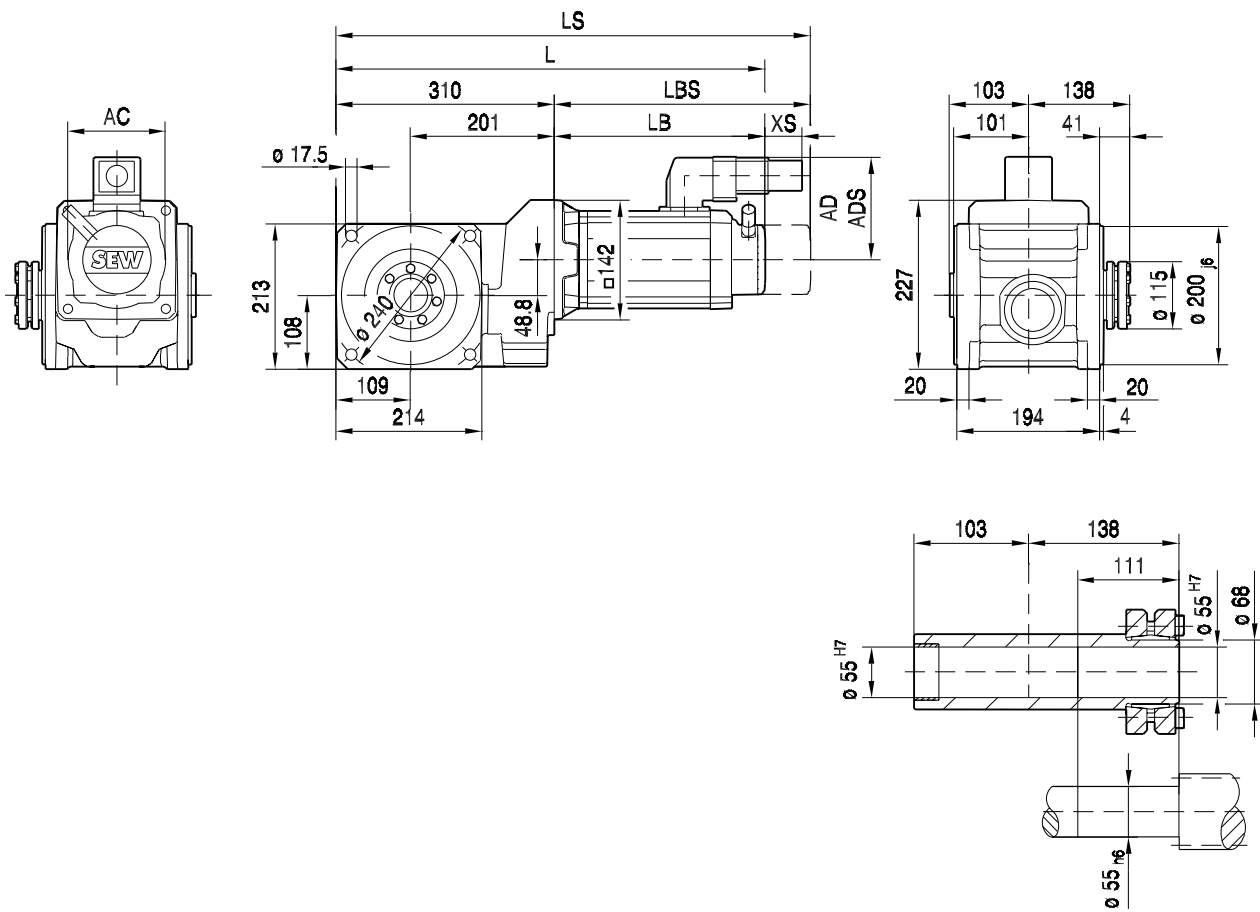

BSHF602/I..
56 015 00 03

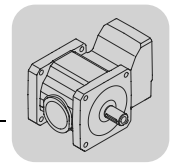
(→ 90)	CFM71S	CFM71M	CFM71L	CFM90S	CFM90M	CFM90L	CFM112S	CFM112M	CFM112L		
AC	117	117	117	142	142	142	186	186	186		
AD	122	122	122	140	140	140	165	165	165		
ADS	122	122	122	140	140	140	165	165	165		
L	536	556	596	588	615	669	623	650	707		
LS	618	638	678	684	711	765	713	740	797		
LB	226	246	286	278	305	359	313	340	397		
LBS	308	328	368	374	401	455	403	430	487		
XS	45	45	45	50	50	50	36	36	36		

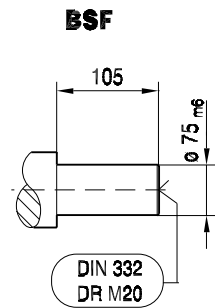
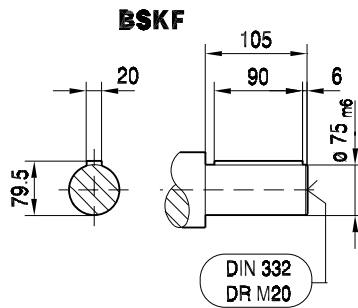
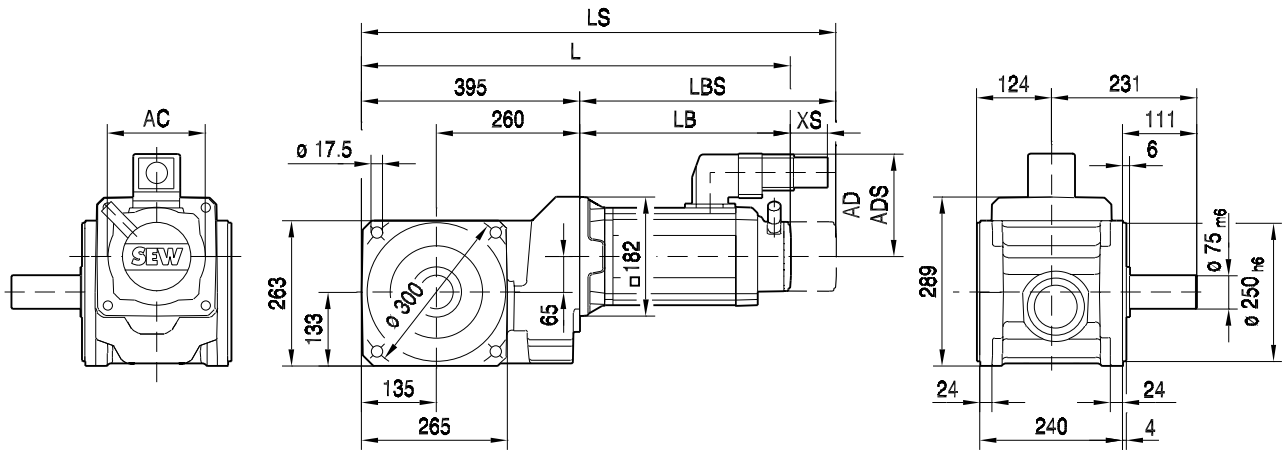

BSF802..

56 016 00 03



7

(→ 90)	CFM90M	CFM90L	CFM112S	CFM112M	CFM112L	CFM112H				
AC	142	142	186	186	186	186				
AD	140	140	165	165	165	165				
ADS	140	140	165	165	165	165				
L	696	750	704	731	788	922				
LS	792	846	794	821	878	987				
LB	301	355	309	336	393	527				
LBS	397	451	399	426	483	592				
XS	50	50	36	36	36	36				

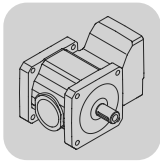
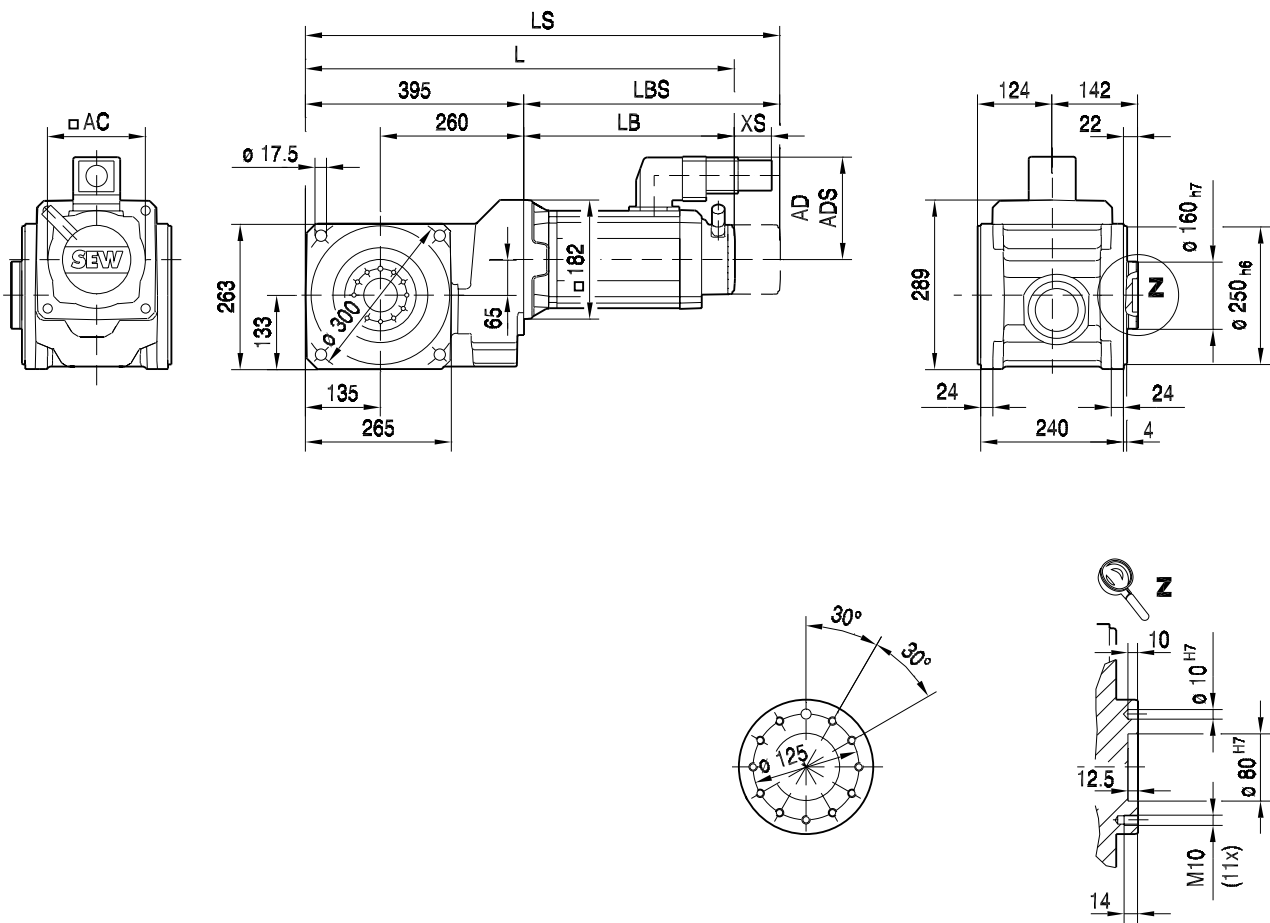

BSBF802..
56 017 00 03

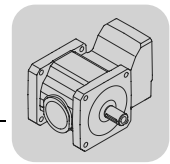
(→ 90)	CFM90M	CFM90L	CFM112S	CFM112M	CFM112L	CFM112H				
AC	142	142	186	186	186	186				
AD	140	140	165	165	165	165				
ADS	140	140	165	165	165	165				
L	696	750	704	731	788	922				
LS	792	846	794	821	878	987				
LB	301	355	309	336	393	527				
LBS	397	451	399	426	483	592				
XS	50	50	36	36	36	36				

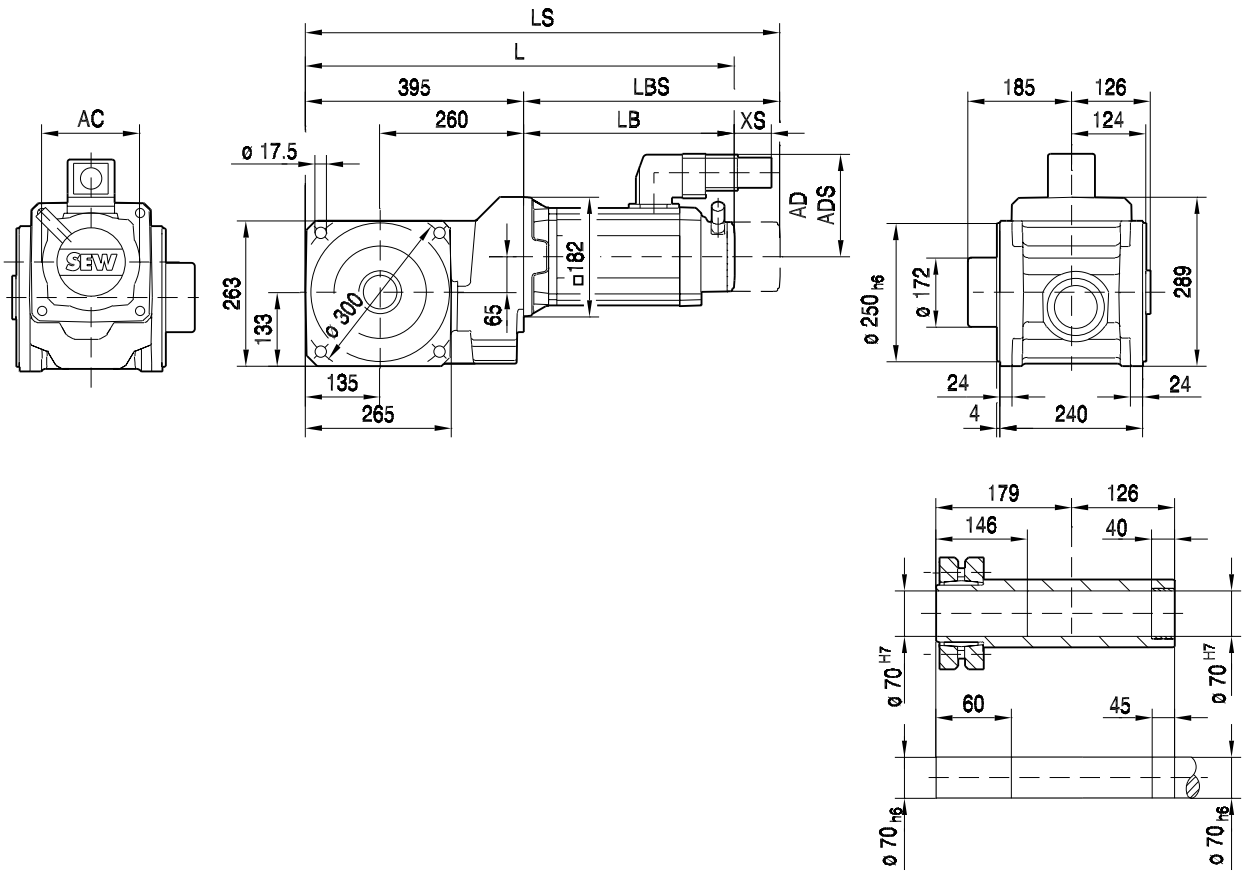

BSHF802..

56 054 00 03



7

(→ 90)	CFM90M	CFM90L	CFM112S	CFM112M	CFM112L	CFM112H				
AC	142	142	186	186	186	186				
AD	140	140	165	165	165	165				
ADS	140	140	165	165	165	165				
L	696	750	704	731	788	922				
LS	792	846	794	821	878	987				
LB	301	355	309	336	393	527				
LBS	397	451	399	426	483	592				
XS	50	50	36	36	36	36				

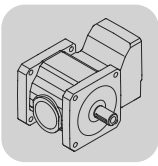
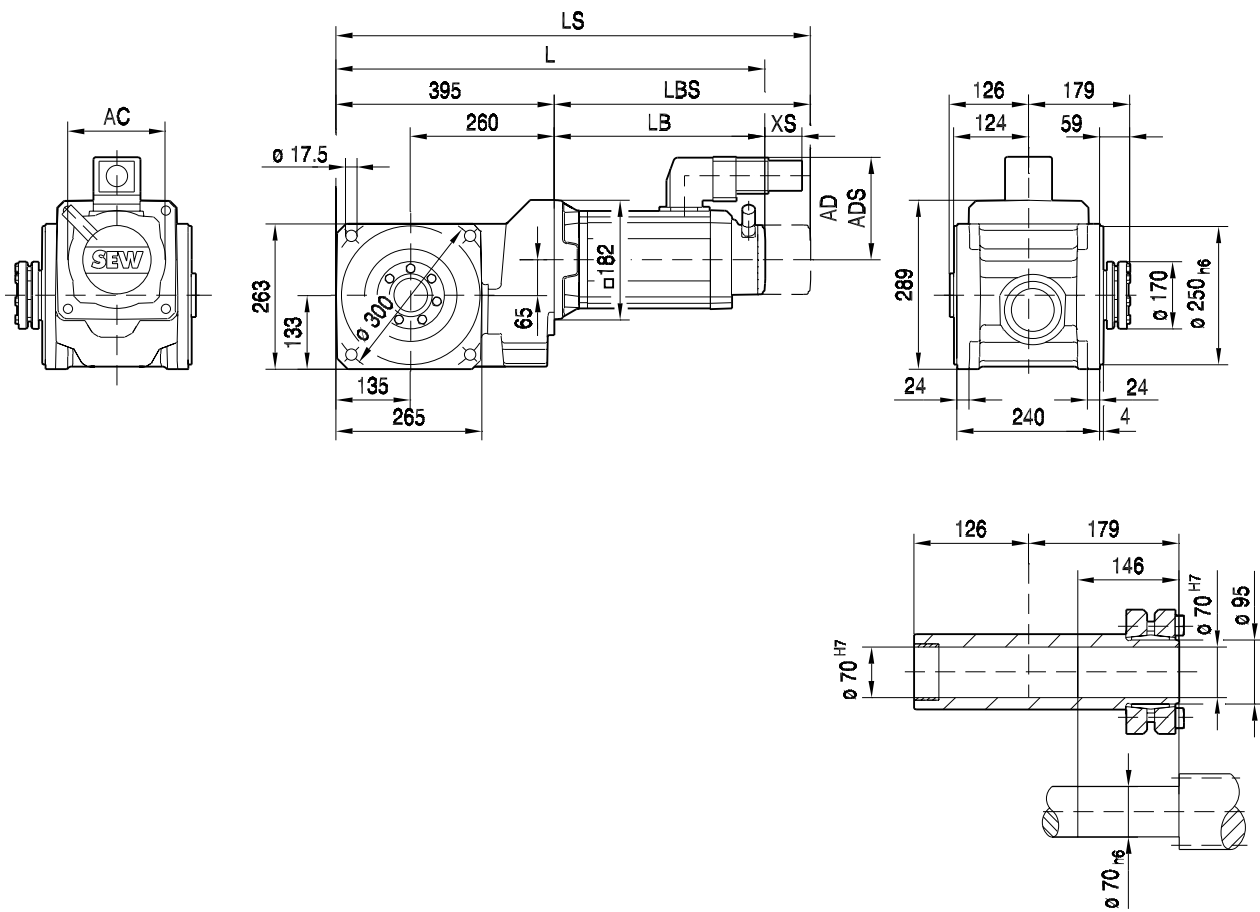

BSHF802/I..
56 018 00 03

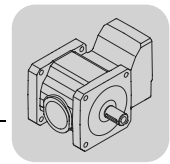
(→ 90)	CFM90M	CFM90L	CFM112S	CFM112M	CFM112L	CFM112H				
AC	142	142	186	186	186	186				
AD	140	140	165	165	165	165				
ADS	140	140	165	165	165	165				
L	696	750	704	731	788	922				
LS	792	846	794	821	878	987				
LB	301	355	309	336	393	527				
LBS	397	451	399	426	483	592				
XS	50	50	36	36	36	36				

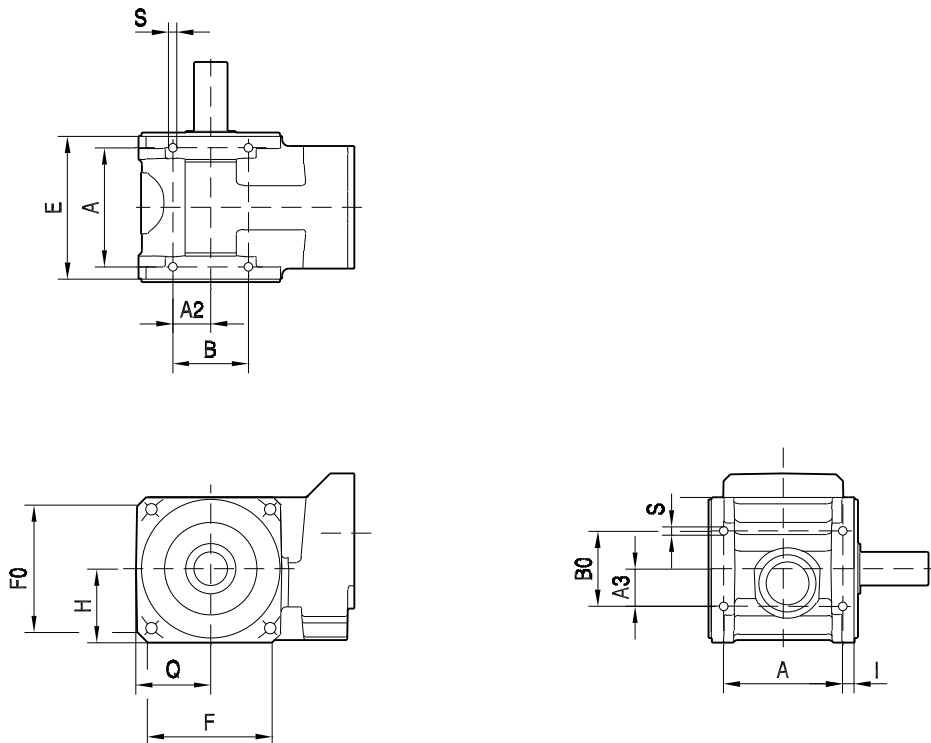

BS..B

55 037 00 03



(→ 90)	E	A	S	A2	B	F	H	Q	F0	B0	A3	I
BSF..202B	111	96	M8x14	30	60	80	47 _{-0.3}	47 _{-0.3}	78	60	30	7.5
BSF..302B	123	105	M10x18	37.5	75	101	58.5 _{-0.3}	58.5 _{-0.3}	98.5	75	37.5	9
BSF..402B	145	120	M12x22	46.5	93	127	72 _{-0.3}	72 _{-0.3}	125	93	46.5	12.5
BSF..502B	170	142	M12x16	45	90	151	86 _{-0.5}	86 _{-0.5}	151	90	45	14
BSF..602B	194	160	M16x20	50	100	182	106 _{-0.5}	106 _{-0.5}	183	100	50	17
BSF..802B	240	186	M20x25	65	130	239	131 _{-0.5}	131 _{-0.5}	237	130	65	27

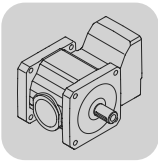

BSHF../T

55 038 00 03

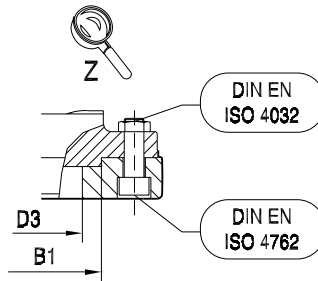
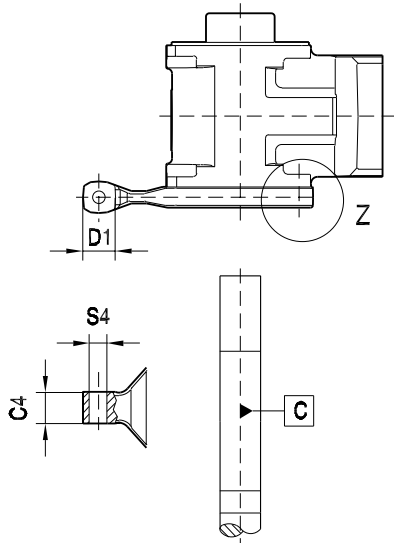
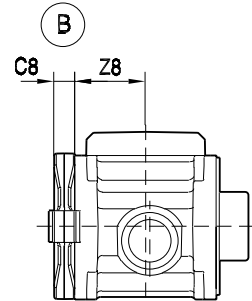
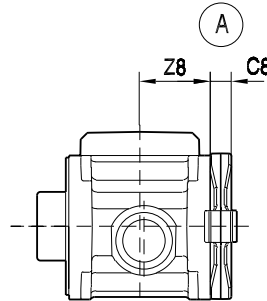
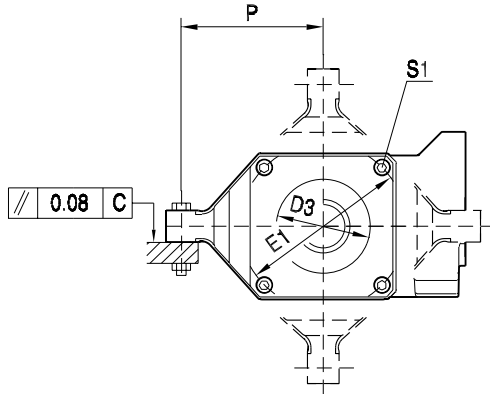

(→ 90°)	P	B1	E1	D3	Z8	C8	D1	S4	C4	S1						
BSHF202/T	110	90	109	75	55.5	18	34	14	20	M6x35						
BSHF302/T	140	110	135	90	61.5	20	38	14	24	M8x40						
BSHF402/T	158	140	168	115	72.5	22	38	14	28	M10x45						
BSHF502/T	170	165	200	140	85	25	38	14	38	M12x40						
BSHF602/T	198	200	240	140	97	35	58	22	50	M16x55						
BSHF802/T	278	250	300	195	120	34	58	22	70	M16x55						

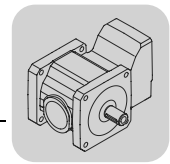

7.6 BS.. EBH.. [mm]

55 003 00 03

BSF202..

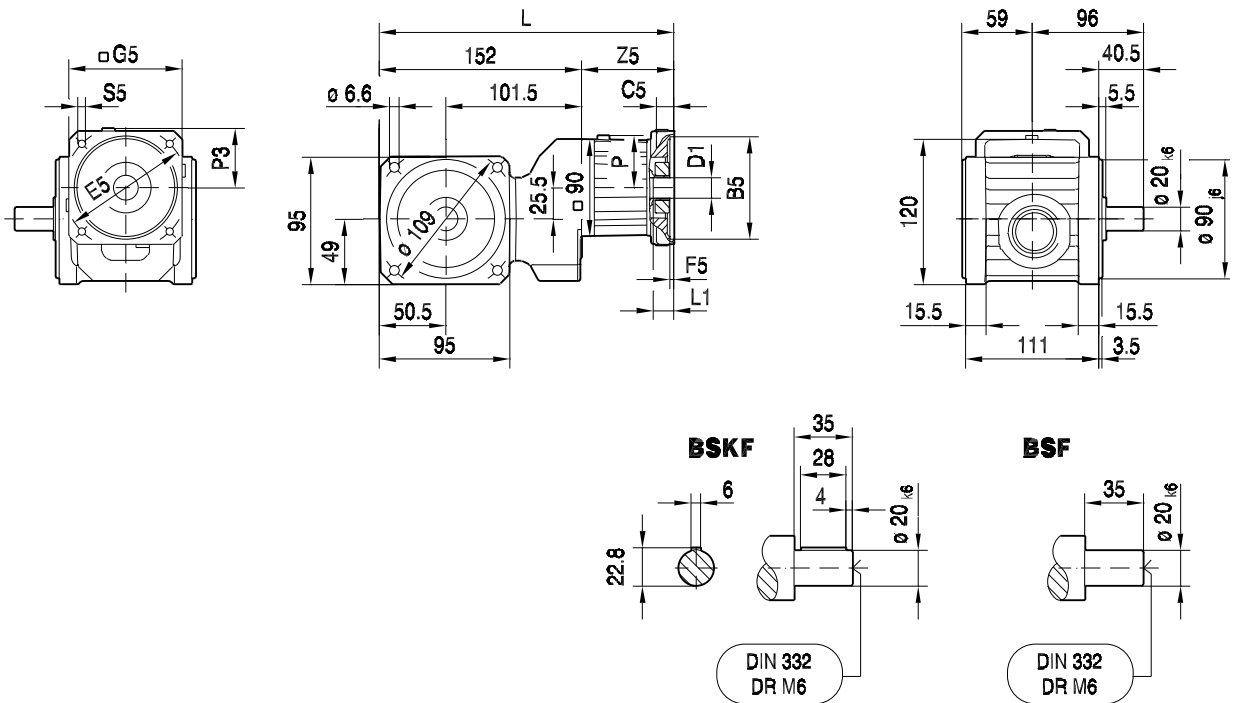

(→ 90)	L	B5	C5	E5	F5	G5	S5	Z5	L1	P	P3	D1
EBH03/03	237	50	20	60	3.5	90	M4	86	41	45	47	8, 9, 10, 11, 12, 14
EBH03/04	237	50	20	70	3.5	90	M5	86	41	45	47	8, 9, 10, 11, 12, 14
EBH03/05	237	50	20	80	3.5	90	M4	86	41	45	47	8, 9, 10, 11, 12, 14
EBH03/06	237	50	20	95	3.5	90	M6	86	41	45	47	8, 9, 10, 11, 12, 14
EBH03/07	237	50	20	100	3.5	90	M6	86	41	45	47	8, 9, 10, 11, 12, 14
EBH03/08	237	60	20	75	3.5	90	M5	86	41	45	47	8, 9, 10, 11, 12, 14
EBH03/09	237	60	20	90	3.5	90	M5	86	41	45	47	8, 9, 10, 11, 12, 14
EBH03/10	237	70	20	85	3.5	90	M6	86	41	45	47	8, 9, 10, 11, 12, 14
EBH03/11	237	70	20	90	3.5	90	M5	86	41	45	47	8, 9, 10, 11, 12, 14
EBH03/13	237	80	20	100	3.5	90	M6	86	41	45	47	8, 9, 10, 11, 12, 14
EBH03/14	237	95	16	115	4.0	105	M8	86	41	45	55	8, 9, 10, 11, 12, 14
EBH04/12	237	70	20	90	3.5	90	M6	86	41	45	47	14, 16, 19
EBH04/13	237	80	20	100	3.5	90	M6	86	41	45	47	14, 16, 19
EBH04/14	237	95	16	115	4.0	105	M8	86	41	45	55	14, 16, 19
EBH04/15	237	95	16	130	4.0	115	M8	86	41	45	60	14, 16, 19

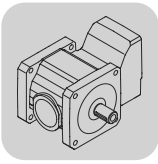
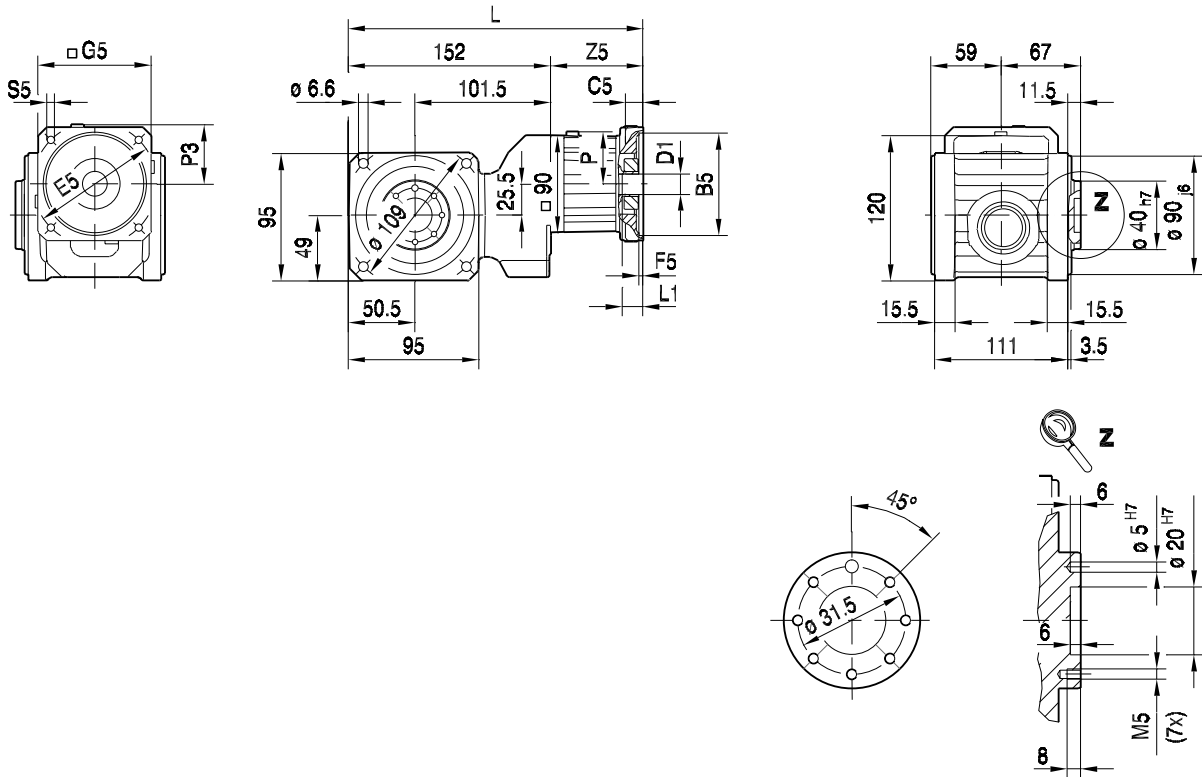

BSBF202..
55 004 00 03

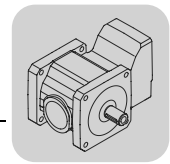
(→ 90)	L	B5	C5	E5	F5	G5	S5	Z5	L1	P	P3	D1
EBH03/03	237	50	20	60	3.5	90	M4	86	41	45	47	8, 9, 10, 11, 12, 14
EBH03/04	237	50	20	70	3.5	90	M5	86	41	45	47	8, 9, 10, 11, 12, 14
EBH03/05	237	50	20	80	3.5	90	M4	86	41	45	47	8, 9, 10, 11, 12, 14
EBH03/06	237	50	20	95	3.5	90	M6	86	41	45	47	8, 9, 10, 11, 12, 14
EBH03/07	237	50	20	100	3.5	90	M6	86	41	45	47	8, 9, 10, 11, 12, 14
EBH03/08	237	60	20	75	3.5	90	M5	86	41	45	47	8, 9, 10, 11, 12, 14
EBH03/09	237	60	20	90	3.5	90	M5	86	41	45	47	8, 9, 10, 11, 12, 14
EBH03/10	237	70	20	85	3.5	90	M6	86	41	45	47	8, 9, 10, 11, 12, 14
EBH03/11	237	70	20	90	3.5	90	M5	86	41	45	47	8, 9, 10, 11, 12, 14
EBH03/13	237	80	20	100	3.5	90	M6	86	41	45	47	8, 9, 10, 11, 12, 14
EBH03/14	237	95	16	115	4.0	105	M8	86	41	45	55	8, 9, 10, 11, 12, 14
EBH04/12	237	70	20	90	3.5	90	M6	86	41	45	47	14, 16, 19
EBH04/13	237	80	20	100	3.5	90	M6	86	41	45	47	14, 16, 19
EBH04/14	237	95	16	115	4.0	105	M8	86	41	45	55	14, 16, 19
EBH04/15	237	95	16	130	4.0	115	M8	86	41	45	60	14, 16, 19

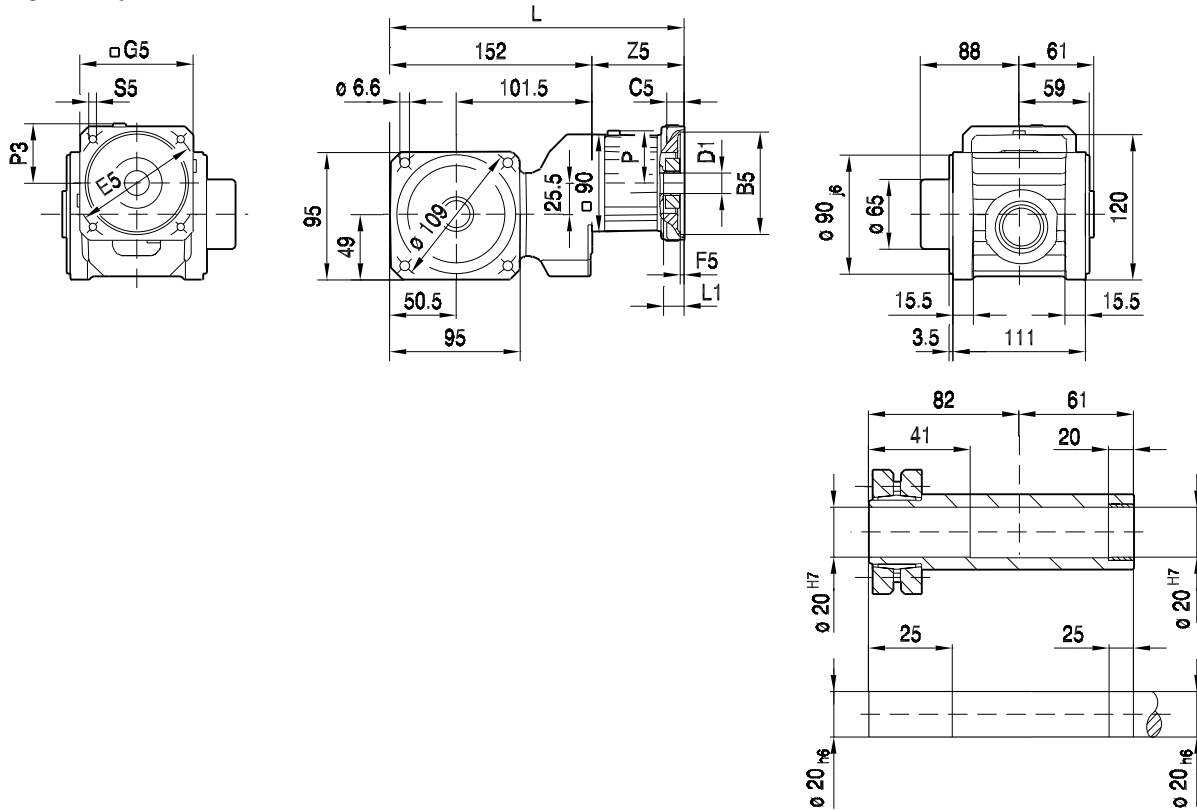

BSHF202..

55 021 00 03



7

(→ 90)	L	B5	C5	E5	F5	G5	S5	Z5	L1	P	P3	D1
EBH03/03	237	50	20	60	3.5	90	M4	86	41	45	47	8, 9, 10, 11, 12, 14
EBH03/04	237	50	20	70	3.5	90	M5	86	41	45	47	8, 9, 10, 11, 12, 14
EBH03/05	237	50	20	80	3.5	90	M4	86	41	45	47	8, 9, 10, 11, 12, 14
EBH03/06	237	50	20	95	3.5	90	M6	86	41	45	47	8, 9, 10, 11, 12, 14
EBH03/07	237	50	20	100	3.5	90	M6	86	41	45	47	8, 9, 10, 11, 12, 14
EBH03/08	237	60	20	75	3.5	90	M5	86	41	45	47	8, 9, 10, 11, 12, 14
EBH03/09	237	60	20	90	3.5	90	M5	86	41	45	47	8, 9, 10, 11, 12, 14
EBH03/10	237	70	20	85	3.5	90	M6	86	41	45	47	8, 9, 10, 11, 12, 14
EBH03/11	237	70	20	90	3.5	90	M5	86	41	45	47	8, 9, 10, 11, 12, 14
EBH03/13	237	80	20	100	3.5	90	M6	86	41	45	47	8, 9, 10, 11, 12, 14
EBH03/14	237	95	16	115	4.0	105	M8	86	41	45	55	8, 9, 10, 11, 12, 14
EBH04/12	237	70	20	90	3.5	90	M6	86	41	45	47	14, 16, 19
EBH04/13	237	80	20	100	3.5	90	M6	86	41	45	47	14, 16, 19
EBH04/14	237	95	16	115	4.0	105	M8	86	41	45	55	14, 16, 19
EBH04/15	237	95	16	130	4.0	115	M8	86	41	45	60	14, 16, 19

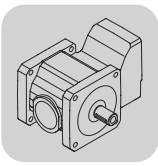

BSF..
BS.. EBH.. [mm]

BSHF202/I..

55 005 00 03

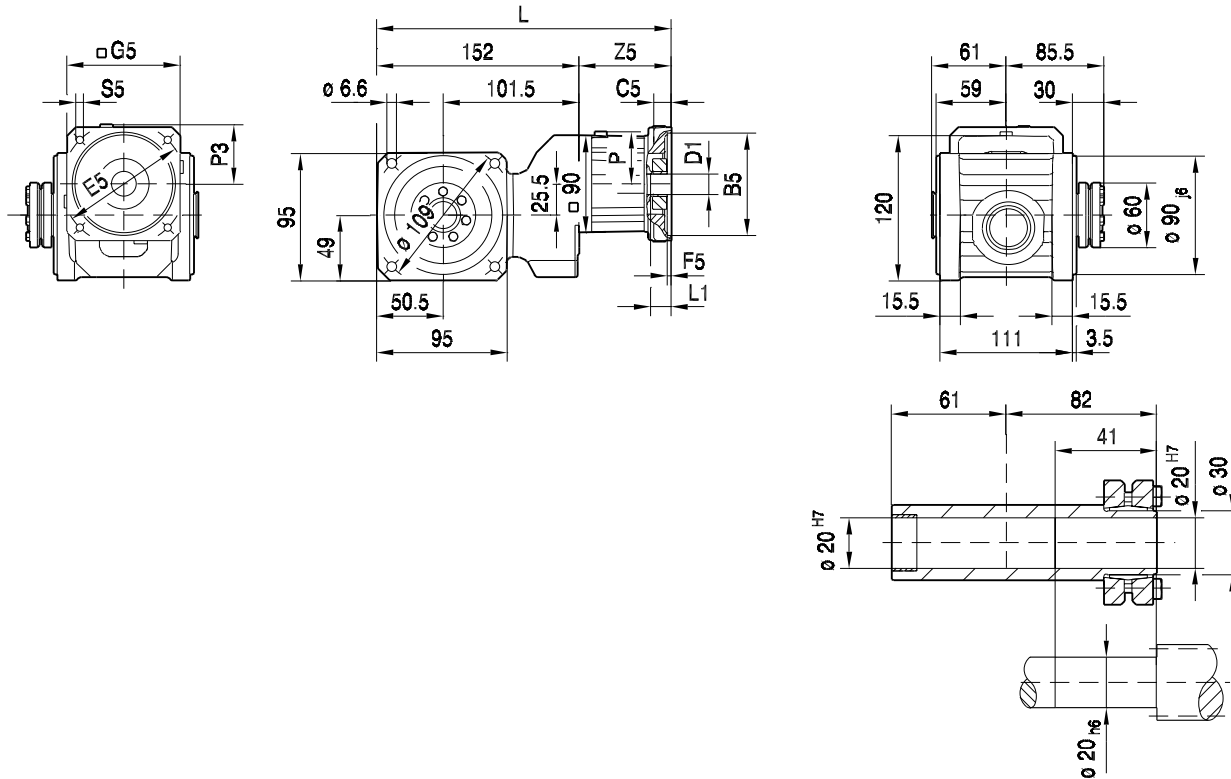

(→ 90)	L	B5	C5	E5	F5	G5	S5	Z5	L1	P	P3	D1
EBH03/03	237	50	20	60	3.5	90	M4	86	41	45	47	8, 9, 10, 11, 12, 14
EBH03/04	237	50	20	70	3.5	90	M5	86	41	45	47	8, 9, 10, 11, 12, 14
EBH03/05	237	50	20	80	3.5	90	M4	86	41	45	47	8, 9, 10, 11, 12, 14
EBH03/06	237	50	20	95	3.5	90	M6	86	41	45	47	8, 9, 10, 11, 12, 14
EBH03/07	237	50	20	100	3.5	90	M6	86	41	45	47	8, 9, 10, 11, 12, 14
EBH03/08	237	60	20	75	3.5	90	M5	86	41	45	47	8, 9, 10, 11, 12, 14
EBH03/09	237	60	20	90	3.5	90	M5	86	41	45	47	8, 9, 10, 11, 12, 14
EBH03/10	237	70	20	85	3.5	90	M6	86	41	45	47	8, 9, 10, 11, 12, 14
EBH03/11	237	70	20	90	3.5	90	M5	86	41	45	47	8, 9, 10, 11, 12, 14
EBH03/13	237	80	20	100	3.5	90	M6	86	41	45	47	8, 9, 10, 11, 12, 14
EBH03/14	237	95	16	115	4.0	105	M8	86	41	45	55	8, 9, 10, 11, 12, 14
EBH04/12	237	70	20	90	3.5	90	M6	86	41	45	47	14, 16, 19
EBH04/13	237	80	20	100	3.5	90	M6	86	41	45	47	14, 16, 19
EBH04/14	237	95	16	115	4.0	105	M8	86	41	45	55	14, 16, 19
EBH04/15	237	95	16	130	4.0	115	M8	86	41	45	60	14, 16, 19

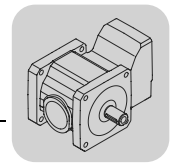

55 006 00 03

BSF302..

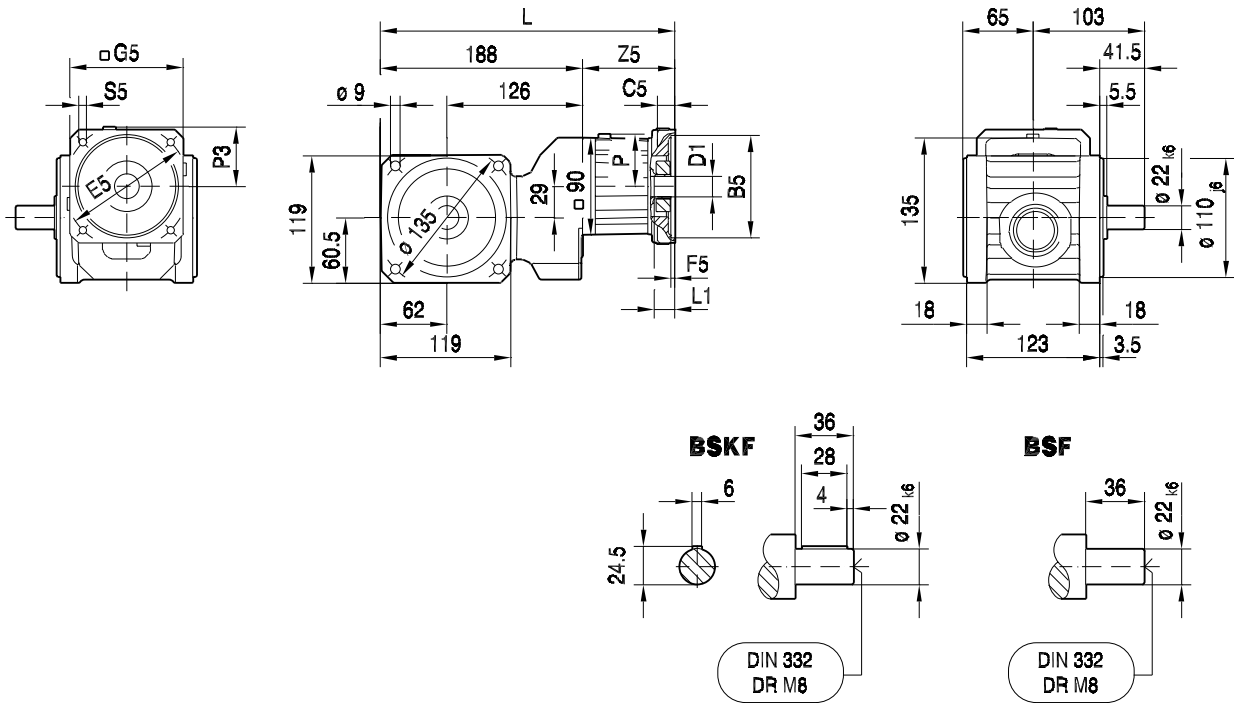

(→ 90)	L	B5	C5	E5	F5	G5	S5	Z5	L1	P	P3	D1
EBH03/03	273	50	20	60	3.5	90	M4	86	41	45	47	8, 9, 10, 11, 12, 14
EBH03/04	273	50	20	70	3.5	90	M5	86	41	45	47	8, 9, 10, 11, 12, 14
EBH03/05	273	50	20	80	3.5	90	M4	86	41	45	47	8, 9, 10, 11, 12, 14
EBH03/06	273	50	20	95	3.5	90	M6	86	41	45	47	8, 9, 10, 11, 12, 14
EBH03/07	273	50	20	100	3.5	90	M6	86	41	45	47	8, 9, 10, 11, 12, 14
EBH03/08	273	60	20	75	3.5	90	M5	86	41	45	47	8, 9, 10, 11, 12, 14
EBH03/09	273	60	20	90	3.5	90	M5	86	41	45	47	8, 9, 10, 11, 12, 14
EBH03/10	273	70	20	85	3.5	90	M6	86	41	45	47	8, 9, 10, 11, 12, 14
EBH03/11	273	70	20	90	3.5	90	M5	86	41	45	47	8, 9, 10, 11, 12, 14
EBH03/13	273	80	20	100	3.5	90	M6	86	41	45	47	8, 9, 10, 11, 12, 14
EBH03/14	273	95	16	115	4.0	105	M8	86	41	45	55	8, 9, 10, 11, 12, 14
EBH04/12	273	70	20	90	3.5	90	M6	86	41	45	47	14, 16, 19
EBH04/13	273	80	20	100	3.5	90	M6	86	41	45	47	14, 16, 19
EBH04/14	273	95	16	115	4.0	105	M8	86	41	45	55	14, 16, 19
EBH04/15	273	95	16	130	4.0	115	M8	86	41	45	60	14, 16, 19
EBH05/14	301	95	16	115	5.0	120	M8	114	56	56	62	14, 16, 17, 18, 19, 24
EBH05/15	301	95	16	130	5.0	120	M8	114	56	56	62	14, 16, 17, 18, 19, 24
EBH05/16	301	110	16	130	5.0	120	M8	114	56	56	62	14, 16, 17, 18, 19, 24
EBH05/17	301	110	16	145	5.0	120	M8	114	56	56	62	14, 16, 17, 18, 19, 24
EBH05/18	301	110	20	165	5.0	140	M10	114	56	56	72	14, 16, 17, 18, 19, 24
EBH05/20	301	130	20	165	5.0	140	M10	114	56	56	72	14, 16, 17, 18, 19, 24

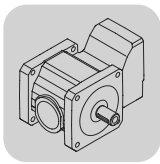
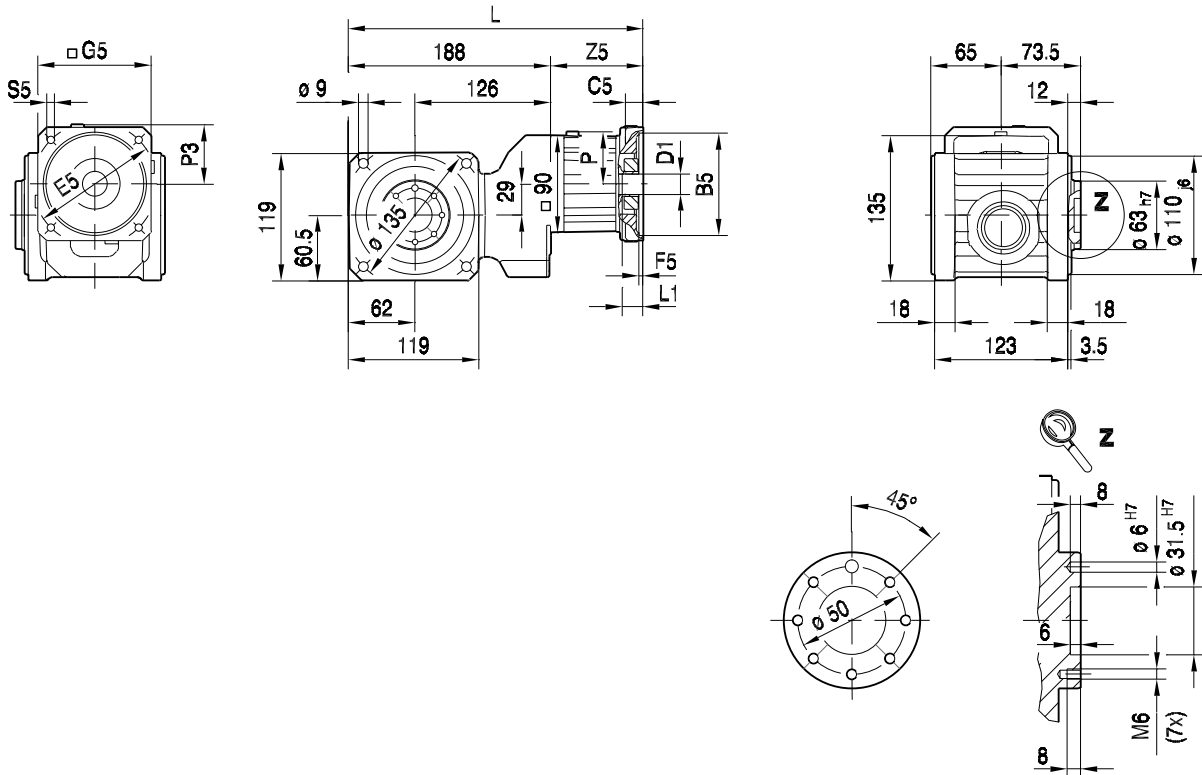

BSBF302..
55 007 00 03

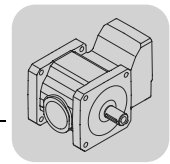
(→ 90)	L	B5	C5	E5	F5	G5	S5	Z5	L1	P	P3	D1
EBH03/03	273	50	20	60	3.5	90	M4	86	41	45	47	8, 9, 10, 11, 12, 14
EBH03/04	273	50	20	70	3.5	90	M5	86	41	45	47	8, 9, 10, 11, 12, 14
EBH03/05	273	50	20	80	3.5	90	M4	86	41	45	47	8, 9, 10, 11, 12, 14
EBH03/06	273	50	20	95	3.5	90	M6	86	41	45	47	8, 9, 10, 11, 12, 14
EBH03/07	273	50	20	100	3.5	90	M6	86	41	45	47	8, 9, 10, 11, 12, 14
EBH03/08	273	60	20	75	3.5	90	M5	86	41	45	47	8, 9, 10, 11, 12, 14
EBH03/09	273	60	20	90	3.5	90	M5	86	41	45	47	8, 9, 10, 11, 12, 14
EBH03/10	273	70	20	85	3.5	90	M6	86	41	45	47	8, 9, 10, 11, 12, 14
EBH03/11	273	70	20	90	3.5	90	M5	86	41	45	47	8, 9, 10, 11, 12, 14
EBH03/13	273	80	20	100	3.5	90	M6	86	41	45	47	8, 9, 10, 11, 12, 14
EBH03/14	273	95	16	115	4.0	105	M8	86	41	45	55	8, 9, 10, 11, 12, 14
EBH04/12	273	70	20	90	3.5	90	M6	86	41	45	47	14, 16, 19
EBH04/13	273	80	20	100	3.5	90	M6	86	41	45	47	14, 16, 19
EBH04/14	273	95	16	115	4.0	105	M8	86	41	45	55	14, 16, 19
EBH04/15	273	95	16	130	4.0	115	M8	86	41	45	60	14, 16, 19
EBH05/14	301	95	16	115	5.0	120	M8	114	56	56	62	14, 16, 17, 18, 19, 24
EBH05/15	301	95	16	130	5.0	120	M8	114	56	56	62	14, 16, 17, 18, 19, 24
EBH05/16	301	110	16	130	5.0	120	M8	114	56	56	62	14, 16, 17, 18, 19, 24
EBH05/17	301	110	16	145	5.0	120	M8	114	56	56	62	14, 16, 17, 18, 19, 24
EBH05/18	301	110	20	165	5.0	140	M10	114	56	56	72	14, 16, 17, 18, 19, 24
EBH05/20	301	130	20	165	5.0	140	M10	114	56	56	72	14, 16, 17, 18, 19, 24

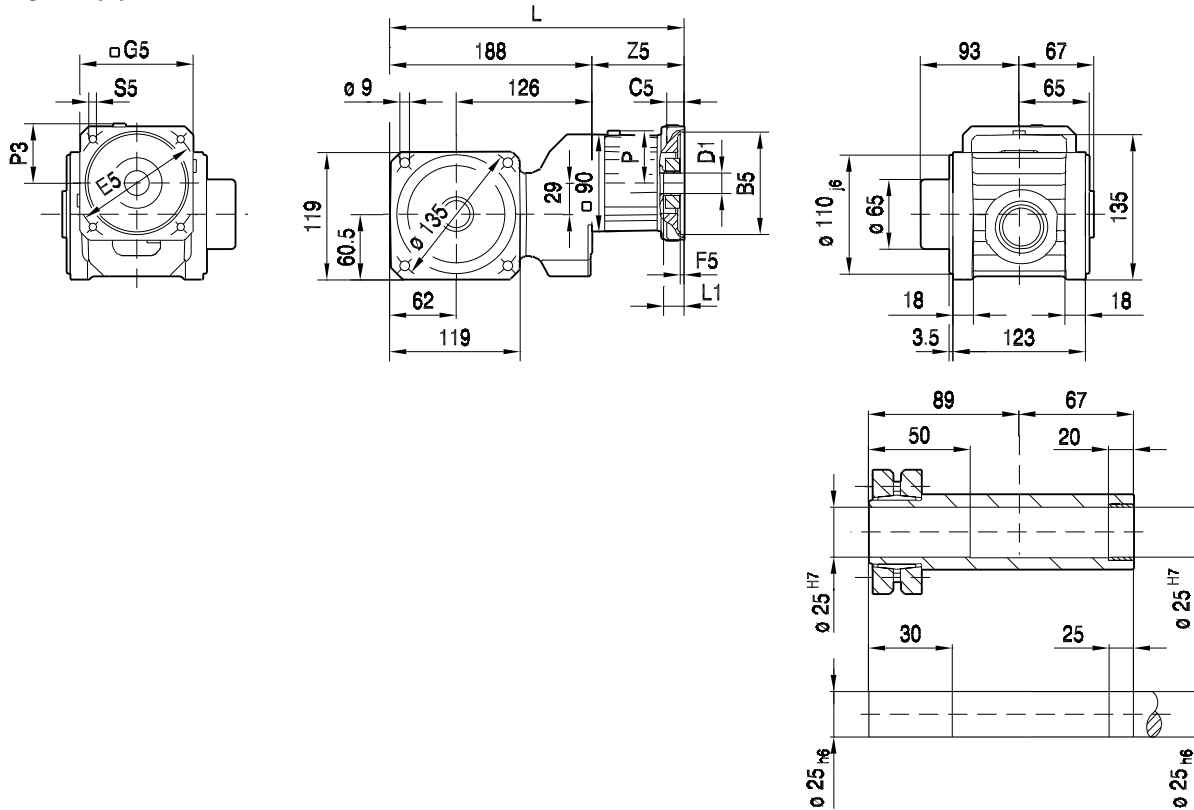

BSHF302..

55 023 00 03



(→ 90)	L	B5	C5	E5	F5	G5	S5	Z5	L1	P	P3	D1
EBH03/03	273	50	20	60	3.5	90	M4	86	41	45	47	8, 9, 10, 11, 12, 14
EBH03/04	273	50	20	70	3.5	90	M5	86	41	45	47	8, 9, 10, 11, 12, 14
EBH03/05	273	50	20	80	3.5	90	M4	86	41	45	47	8, 9, 10, 11, 12, 14
EBH03/06	273	50	20	95	3.5	90	M6	86	41	45	47	8, 9, 10, 11, 12, 14
EBH03/07	273	50	20	100	3.5	90	M6	86	41	45	47	8, 9, 10, 11, 12, 14
EBH03/08	273	60	20	75	3.5	90	M5	86	41	45	47	8, 9, 10, 11, 12, 14
EBH03/09	273	60	20	90	3.5	90	M5	86	41	45	47	8, 9, 10, 11, 12, 14
EBH03/10	273	70	20	85	3.5	90	M6	86	41	45	47	8, 9, 10, 11, 12, 14
EBH03/11	273	70	20	90	3.5	90	M5	86	41	45	47	8, 9, 10, 11, 12, 14
EBH03/13	273	80	20	100	3.5	90	M6	86	41	45	47	8, 9, 10, 11, 12, 14
EBH03/14	273	95	16	115	4.0	105	M8	86	41	45	55	8, 9, 10, 11, 12, 14
EBH04/12	273	70	20	90	3.5	90	M6	86	41	45	47	14, 16, 19
EBH04/13	273	80	20	100	3.5	90	M6	86	41	45	47	14, 16, 19
EBH04/14	273	95	16	115	4.0	105	M8	86	41	45	55	14, 16, 19
EBH04/15	273	95	16	130	4.0	115	M8	86	41	45	60	14, 16, 19
EBH05/14	301	95	16	115	5.0	120	M8	114	56	56	62	14, 16, 17, 18, 19, 24
EBH05/15	301	95	16	130	5.0	120	M8	114	56	56	62	14, 16, 17, 18, 19, 24
EBH05/16	301	110	16	130	5.0	120	M8	114	56	56	62	14, 16, 17, 18, 19, 24
EBH05/17	301	110	16	145	5.0	120	M8	114	56	56	62	14, 16, 17, 18, 19, 24
EBH05/18	301	110	20	165	5.0	140	M10	114	56	56	72	14, 16, 17, 18, 19, 24
EBH05/20	301	130	20	165	5.0	140	M10	114	56	56	72	14, 16, 17, 18, 19, 24

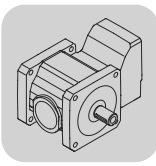

BSF..
BS.. EBH.. [mm]

BSHF302/I..

55 008 00 03

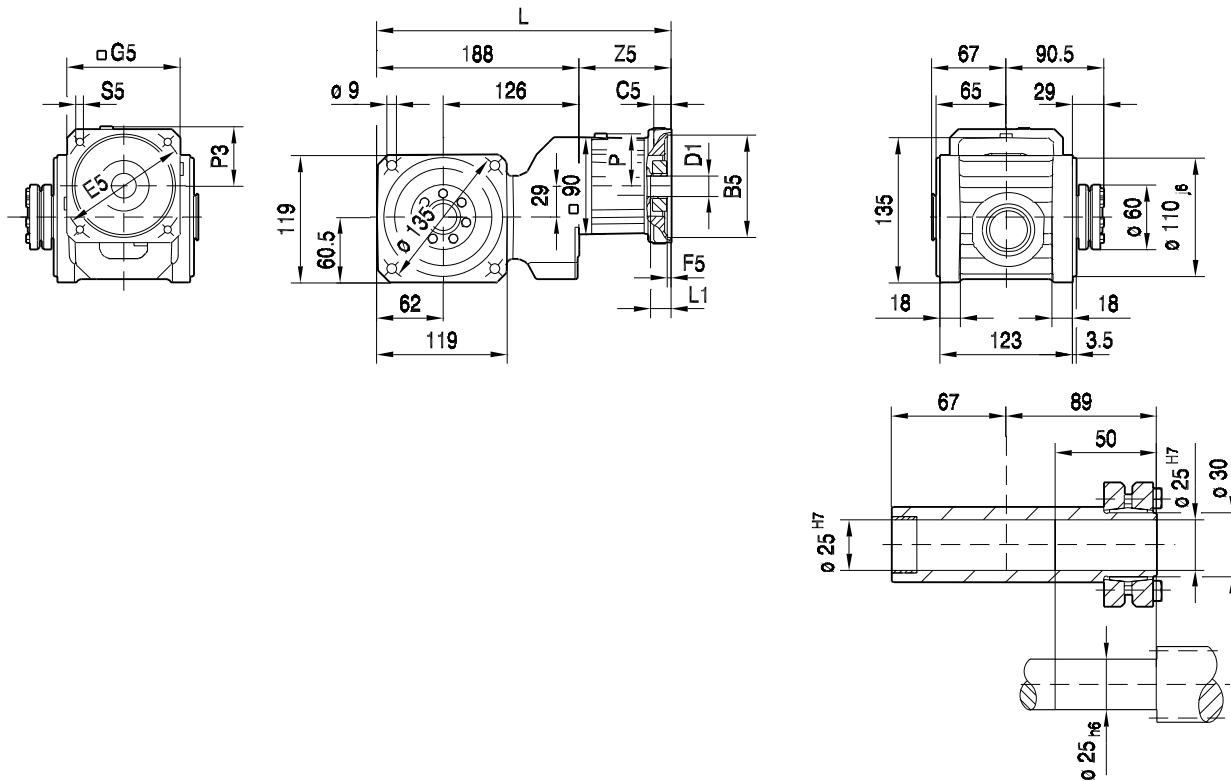

(→ 90)	L	B5	C5	E5	F5	G5	S5	Z5	L1	P	P3	D1
EBH03/03	273	50	20	60	3.5	90	M4	86	41	45	47	8, 9, 10, 11, 12, 14
EBH03/04	273	50	20	70	3.5	90	M5	86	41	45	47	8, 9, 10, 11, 12, 14
EBH03/05	273	50	20	80	3.5	90	M4	86	41	45	47	8, 9, 10, 11, 12, 14
EBH03/06	273	50	20	95	3.5	90	M6	86	41	45	47	8, 9, 10, 11, 12, 14
EBH03/07	273	50	20	100	3.5	90	M6	86	41	45	47	8, 9, 10, 11, 12, 14
EBH03/08	273	60	20	75	3.5	90	M5	86	41	45	47	8, 9, 10, 11, 12, 14
EBH03/09	273	60	20	90	3.5	90	M5	86	41	45	47	8, 9, 10, 11, 12, 14
EBH03/10	273	70	20	85	3.5	90	M6	86	41	45	47	8, 9, 10, 11, 12, 14
EBH03/11	273	70	20	90	3.5	90	M5	86	41	45	47	8, 9, 10, 11, 12, 14
EBH03/13	273	80	20	100	3.5	90	M6	86	41	45	47	8, 9, 10, 11, 12, 14
EBH03/14	273	95	16	115	4.0	105	M8	86	41	45	55	8, 9, 10, 11, 12, 14
EBH04/12	273	70	20	90	3.5	90	M6	86	41	45	47	14, 16, 19
EBH04/13	273	80	20	100	3.5	90	M6	86	41	45	47	14, 16, 19
EBH04/14	273	95	16	115	4.0	105	M8	86	41	45	55	14, 16, 19
EBH04/15	273	95	16	130	4.0	115	M8	86	41	45	60	14, 16, 19
EBH05/14	301	95	16	115	5.0	120	M8	114	56	56	62	14, 16, 17, 18, 19, 24
EBH05/15	301	95	16	130	5.0	120	M8	114	56	56	62	14, 16, 17, 18, 19, 24
EBH05/16	301	110	16	130	5.0	120	M8	114	56	56	62	14, 16, 17, 18, 19, 24
EBH05/17	301	110	16	145	5.0	120	M8	114	56	56	62	14, 16, 17, 18, 19, 24
EBH05/18	301	110	20	165	5.0	140	M10	114	56	56	72	14, 16, 17, 18, 19, 24
EBH05/20	301	130	20	165	5.0	140	M10	114	56	56	72	14, 16, 17, 18, 19, 24

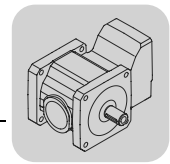

55 009 00 03

BSF402..

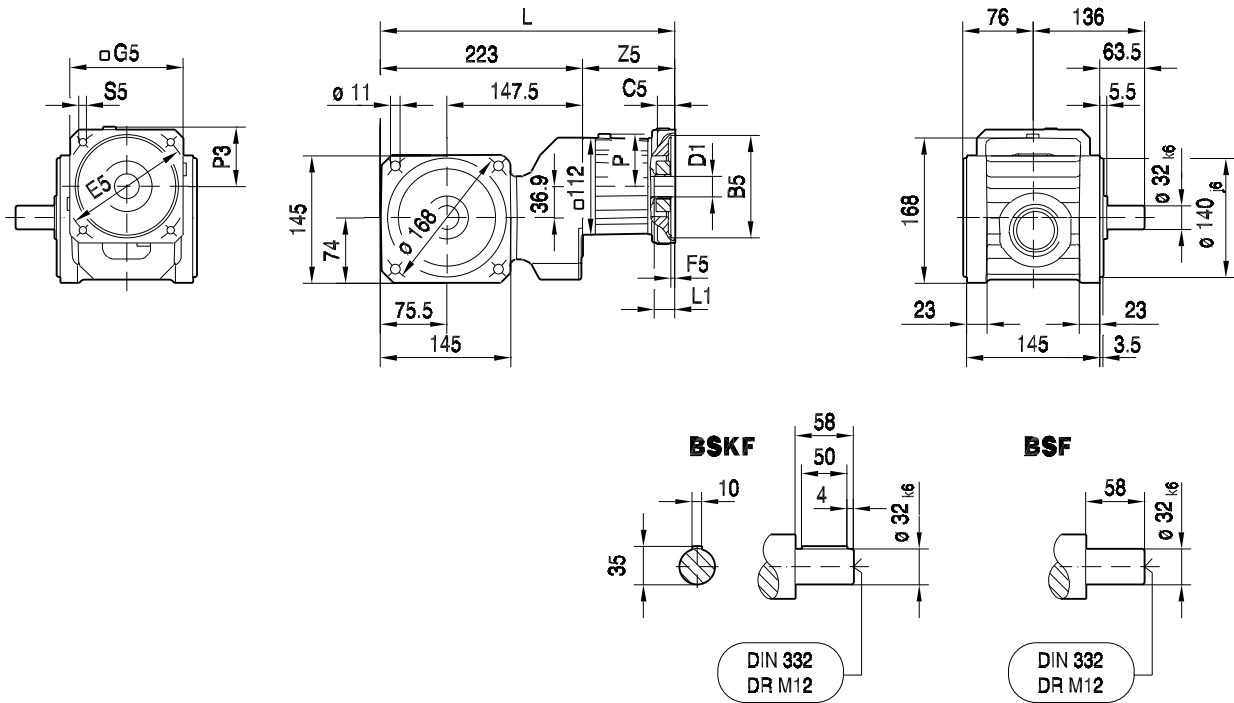

(→ 90)	L	B5	C5	E5	F5	G5	S5	Z5	L1	P	P3	D1
EBH03/03	302	50	20	60	3.5	90	M4	80	41	58	47	8, 9, 10, 11, 12, 14
EBH03/04	302	50	20	70	3.5	90	M5	80	41	58	47	8, 9, 10, 11, 12, 14
EBH03/05	302	50	20	80	3.5	90	M4	80	41	58	47	8, 9, 10, 11, 12, 14
EBH03/06	302	50	20	95	3.5	90	M6	80	41	58	47	8, 9, 10, 11, 12, 14
EBH03/07	302	50	20	100	3.5	90	M6	80	41	58	47	8, 9, 10, 11, 12, 14
EBH03/08	302	60	20	75	3.5	90	M5	80	41	58	47	8, 9, 10, 11, 12, 14
EBH03/09	302	60	20	90	3.5	90	M5	80	41	58	47	8, 9, 10, 11, 12, 14
EBH03/10	302	70	20	85	3.5	90	M6	80	41	58	47	8, 9, 10, 11, 12, 14
EBH03/11	302	70	20	90	3.5	90	M5	80	41	58	47	8, 9, 10, 11, 12, 14
EBH03/13	302	80	20	100	3.5	90	M6	80	41	58	47	8, 9, 10, 11, 12, 14
EBH03/14	302	95	16	115	4.0	105	M8	80	41	58	55	8, 9, 10, 11, 12, 14
EBH04/12	302	70	20	90	3.5	90	M6	80	41	58	47	14, 16, 19
EBH04/13	302	80	20	100	3.5	90	M6	80	41	58	47	14, 16, 19
EBH04/14	302	95	16	115	4.0	105	M8	80	41	58	55	14, 16, 19
EBH04/15	302	95	16	130	4.0	115	M8	80	41	58	60	14, 16, 19
EBH05/14	331	95	16	115	5.0	120	M8	109	56	56	62	14, 16, 17, 18, 19, 24
EBH05/15	331	95	16	130	5.0	120	M8	109	56	56	62	14, 16, 17, 18, 19, 24
EBH05/16	331	110	16	130	5.0	120	M8	109	56	56	62	14, 16, 17, 18, 19, 24
EBH05/17	331	110	16	145	5.0	120	M8	109	56	56	62	14, 16, 17, 18, 19, 24
EBH05/18	331	110	20	165	5.0	140	M10	109	56	56	72	14, 16, 17, 18, 19, 24
EBH05/20	331	130	20	165	5.0	140	M10	109	56	56	72	14, 16, 17, 18, 19, 24
EBH06/19	370	114	24	200	5.0	174	M12	148	86	58	89	35
EBH07/20	350	130	24	165	5.0	155	M10	128	66	58	80	22, 24, 28, 32
EBH07/21	350	130	24	215	5.0	190	M12	128	66	58	97	22, 24, 28, 32
EBH07/22	350	180	24	215	5.0	190	M12	128	66	58	97	22, 24, 28, 32

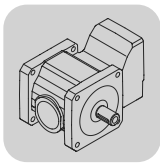
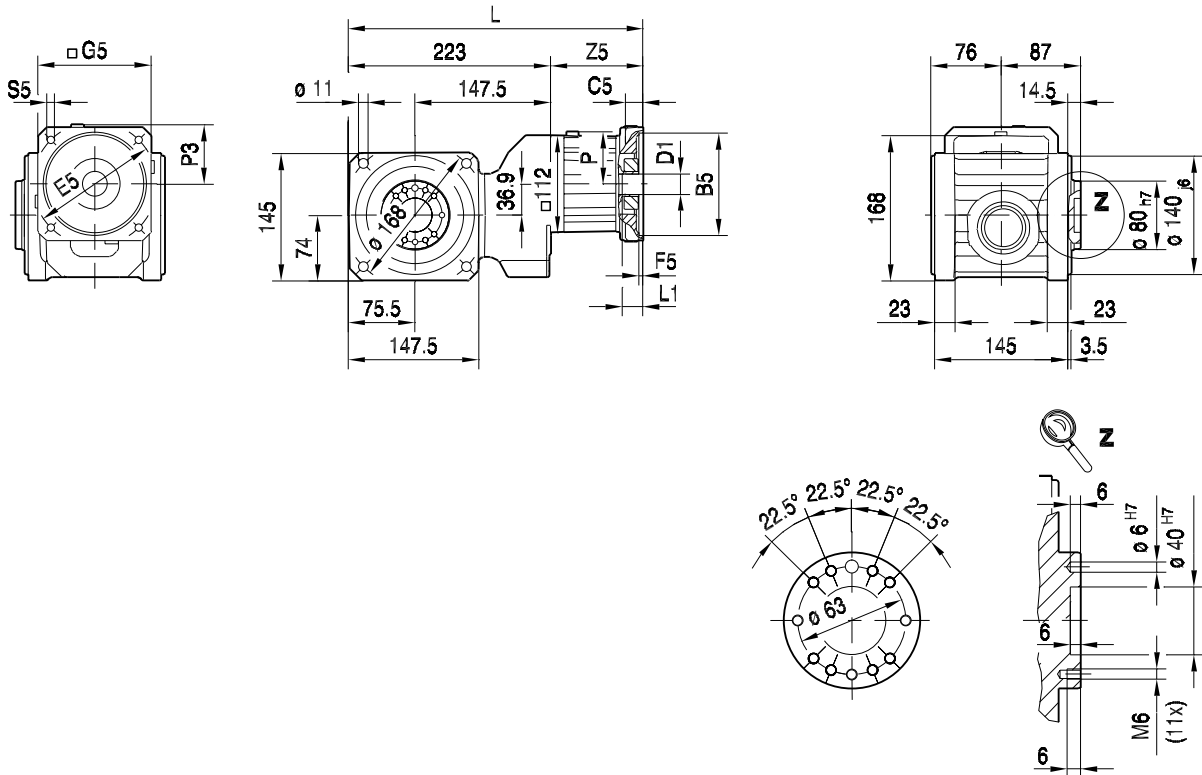

BSBF402..
55 010 00 03

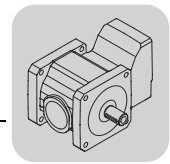
(→ 90)	L	B5	C5	E5	F5	G5	S5	Z5	L1	P	P3	D1
EBH03/03	302	50	20	60	3.5	90	M4	80	41	58	47	8, 9, 10, 11, 12, 14
EBH03/04	302	50	20	70	3.5	90	M5	80	41	58	47	8, 9, 10, 11, 12, 14
EBH03/05	302	50	20	80	3.5	90	M4	80	41	58	47	8, 9, 10, 11, 12, 14
EBH03/06	302	50	20	95	3.5	90	M6	80	41	58	47	8, 9, 10, 11, 12, 14
EBH03/07	302	50	20	100	3.5	90	M6	80	41	58	47	8, 9, 10, 11, 12, 14
EBH03/08	302	60	20	75	3.5	90	M5	80	41	58	47	8, 9, 10, 11, 12, 14
EBH03/09	302	60	20	90	3.5	90	M5	80	41	58	47	8, 9, 10, 11, 12, 14
EBH03/10	302	70	20	85	3.5	90	M6	80	41	58	47	8, 9, 10, 11, 12, 14
EBH03/11	302	70	20	90	3.5	90	M5	80	41	58	47	8, 9, 10, 11, 12, 14
EBH03/13	302	80	20	100	3.5	90	M6	80	41	58	47	8, 9, 10, 11, 12, 14
EBH03/14	302	95	16	115	4.0	105	M8	80	41	58	55	8, 9, 10, 11, 12, 14
EBH04/12	302	70	20	90	3.5	90	M6	80	41	58	47	14, 16, 19
EBH04/13	302	80	20	100	3.5	90	M6	80	41	58	47	14, 16, 19
EBH04/14	302	95	16	115	4.0	105	M8	80	41	58	55	14, 16, 19
EBH04/15	302	95	16	130	4.0	115	M8	80	41	58	60	14, 16, 19
EBH05/14	331	95	16	115	5.0	120	M8	109	56	56	62	14, 16, 17, 18, 19, 24
EBH05/15	331	95	16	130	5.0	120	M8	109	56	56	62	14, 16, 17, 18, 19, 24
EBH05/16	331	110	16	130	5.0	120	M8	109	56	56	62	14, 16, 17, 18, 19, 24
EBH05/17	331	110	16	145	5.0	120	M8	109	56	56	62	14, 16, 17, 18, 19, 24
EBH05/18	331	110	20	165	5.0	140	M10	109	56	56	72	14, 16, 17, 18, 19, 24
EBH05/20	331	130	20	165	5.0	140	M10	109	56	56	72	14, 16, 17, 18, 19, 24
EBH06/19	370	114	24	200	5.0	174	M12	148	86	58	89	35
EBH07/20	350	130	24	165	5.0	155	M10	128	66	58	80	22, 24, 28, 32
EBH07/21	350	130	24	215	5.0	190	M12	128	66	58	97	22, 24, 28, 32
EBH07/22	350	180	24	215	5.0	190	M12	128	66	58	97	22, 24, 28, 32

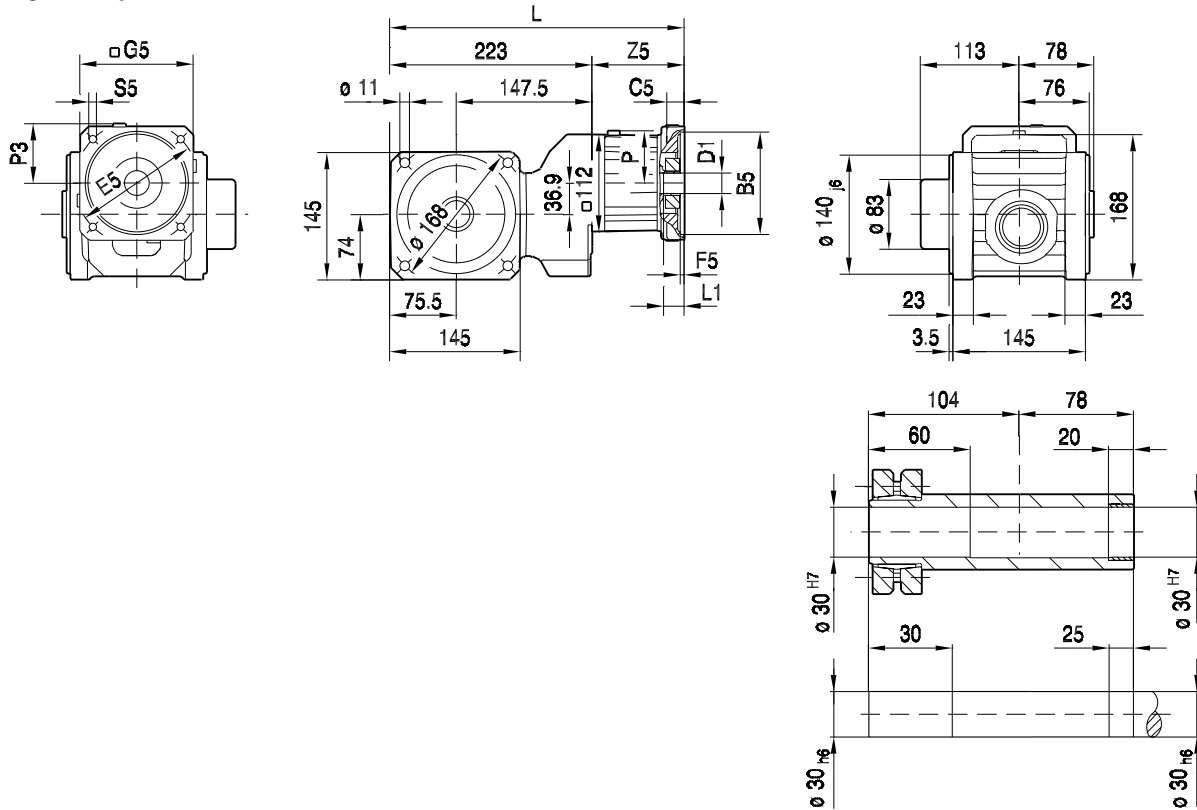

BSHF402..

55 025 00 03



7

(→ 90)	L	B5	C5	E5	F5	G5	S5	Z5	L1	P	P3	D1
EBH03/03	302	50	20	60	3.5	90	M4	80	41	58	47	8, 9, 10, 11, 12, 14
EBH03/04	302	50	20	70	3.5	90	M5	80	41	58	47	8, 9, 10, 11, 12, 14
EBH03/05	302	50	20	80	3.5	90	M4	80	41	58	47	8, 9, 10, 11, 12, 14
EBH03/06	302	50	20	95	3.5	90	M6	80	41	58	47	8, 9, 10, 11, 12, 14
EBH03/07	302	50	20	100	3.5	90	M6	80	41	58	47	8, 9, 10, 11, 12, 14
EBH03/08	302	60	20	75	3.5	90	M5	80	41	58	47	8, 9, 10, 11, 12, 14
EBH03/09	302	60	20	90	3.5	90	M5	80	41	58	47	8, 9, 10, 11, 12, 14
EBH03/10	302	70	20	85	3.5	90	M6	80	41	58	47	8, 9, 10, 11, 12, 14
EBH03/11	302	70	20	90	3.5	90	M5	80	41	58	47	8, 9, 10, 11, 12, 14
EBH03/13	302	80	20	100	3.5	90	M6	80	41	58	47	8, 9, 10, 11, 12, 14
EBH03/14	302	95	16	115	4.0	105	M8	80	41	58	55	8, 9, 10, 11, 12, 14
EBH04/12	302	70	20	90	3.5	90	M6	80	41	58	47	14, 16, 19
EBH04/13	302	80	20	100	3.5	90	M6	80	41	58	47	14, 16, 19
EBH04/14	302	95	16	115	4.0	105	M8	80	41	58	55	14, 16, 19
EBH04/15	302	95	16	130	4.0	115	M8	80	41	58	60	14, 16, 19
EBH05/14	331	95	16	115	5.0	120	M8	109	56	56	62	14, 16, 17, 18, 19, 24
EBH05/15	331	95	16	130	5.0	120	M8	109	56	56	62	14, 16, 17, 18, 19, 24
EBH05/16	331	110	16	130	5.0	120	M8	109	56	56	62	14, 16, 17, 18, 19, 24
EBH05/17	331	110	16	145	5.0	120	M8	109	56	56	62	14, 16, 17, 18, 19, 24
EBH05/18	331	110	20	165	5.0	140	M10	109	56	56	72	14, 16, 17, 18, 19, 24
EBH05/20	331	130	20	165	5.0	140	M10	109	56	56	72	14, 16, 17, 18, 19, 24
EBH06/19	370	114	24	200	5.0	174	M12	148	86	58	89	35
EBH07/20	350	130	24	165	5.0	155	M10	128	66	58	80	22, 24, 28, 32
EBH07/21	350	130	24	215	5.0	190	M12	128	66	58	97	22, 24, 28, 32
EBH07/22	350	180	24	215	5.0	190	M12	128	66	58	97	22, 24, 28, 32

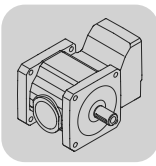

BSF..
BS.. EBH.. [mm]

BSHF402/I..

55 011 00 03

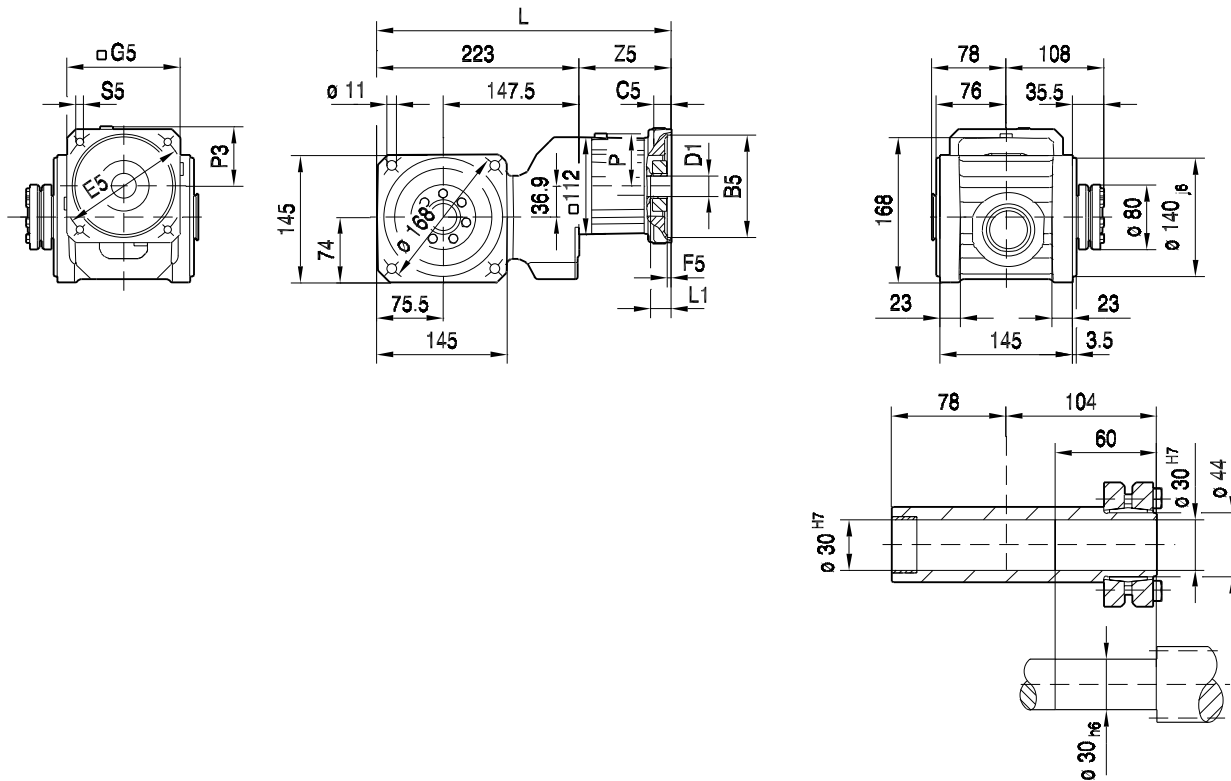

(→ 90)	L	B5	C5	E5	F5	G5	S5	Z5	L1	P	P3	D1
EBH03/03	302	50	20	60	3.5	90	M4	80	41	58	47	8, 9, 10, 11, 12, 14
EBH03/04	302	50	20	70	3.5	90	M5	80	41	58	47	8, 9, 10, 11, 12, 14
EBH03/05	302	50	20	80	3.5	90	M4	80	41	58	47	8, 9, 10, 11, 12, 14
EBH03/06	302	50	20	95	3.5	90	M6	80	41	58	47	8, 9, 10, 11, 12, 14
EBH03/07	302	50	20	100	3.5	90	M6	80	41	58	47	8, 9, 10, 11, 12, 14
EBH03/08	302	60	20	75	3.5	90	M5	80	41	58	47	8, 9, 10, 11, 12, 14
EBH03/09	302	60	20	90	3.5	90	M5	80	41	58	47	8, 9, 10, 11, 12, 14
EBH03/10	302	70	20	85	3.5	90	M6	80	41	58	47	8, 9, 10, 11, 12, 14
EBH03/11	302	70	20	90	3.5	90	M5	80	41	58	47	8, 9, 10, 11, 12, 14
EBH03/13	302	80	20	100	3.5	90	M6	80	41	58	47	8, 9, 10, 11, 12, 14
EBH03/14	302	95	16	115	4.0	105	M8	80	41	58	55	8, 9, 10, 11, 12, 14
EBH04/12	302	70	20	90	3.5	90	M6	80	41	58	47	14, 16, 19
EBH04/13	302	80	20	100	3.5	90	M6	80	41	58	47	14, 16, 19
EBH04/14	302	95	16	115	4.0	105	M8	80	41	58	55	14, 16, 19
EBH04/15	302	95	16	130	4.0	115	M8	80	41	58	60	14, 16, 19
EBH05/14	331	95	16	115	5.0	120	M8	109	56	56	62	14, 16, 17, 18, 19, 24
EBH05/15	331	95	16	130	5.0	120	M8	109	56	56	62	14, 16, 17, 18, 19, 24
EBH05/16	331	110	16	130	5.0	120	M8	109	56	56	62	14, 16, 17, 18, 19, 24
EBH05/17	331	110	16	145	5.0	120	M8	109	56	56	62	14, 16, 17, 18, 19, 24
EBH05/18	331	110	20	165	5.0	140	M10	109	56	56	72	14, 16, 17, 18, 19, 24
EBH05/20	331	130	20	165	5.0	140	M10	109	56	56	72	14, 16, 17, 18, 19, 24
EBH06/19	370	114	24	200	5.0	174	M12	148	86	58	89	35
EBH07/20	350	130	24	165	5.0	155	M10	128	66	58	80	22, 24, 28, 32
EBH07/21	350	130	24	215	5.0	190	M12	128	66	58	97	22, 24, 28, 32
EBH07/22	350	180	24	215	5.0	190	M12	128	66	58	97	22, 24, 28, 32

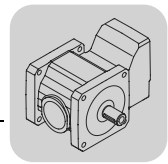

BSF502..

55 012 00 03

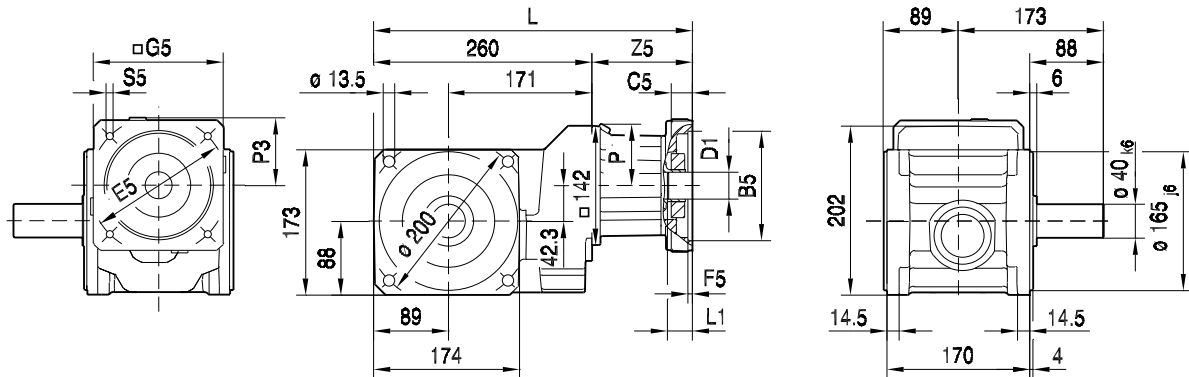

BSKF

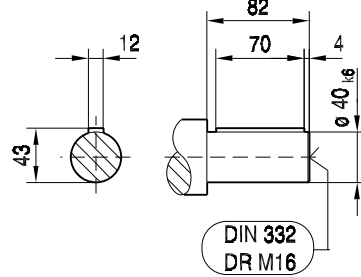

BSF

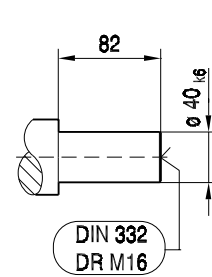

7

(→ 90)	L	B5	C5	E5	F5	G5	S5	Z5	L1	P	P3	D1
EBH03/03	334	50	20	60	3.5	90	M4	74	41	72	47	8, 9, 10, 11, 12, 14
EBH03/04	334	50	20	70	3.5	90	M5	74	41	72	47	8, 9, 10, 11, 12, 14
EBH03/05	334	50	20	80	3.5	90	M4	74	41	72	47	8, 9, 10, 11, 12, 14
EBH03/06	334	50	20	95	3.5	90	M6	74	41	72	47	8, 9, 10, 11, 12, 14
EBH03/07	334	50	20	100	3.5	90	M6	74	41	72	47	8, 9, 10, 11, 12, 14
EBH03/08	334	60	20	75	3.5	90	M5	74	41	72	47	8, 9, 10, 11, 12, 14
EBH03/09	334	60	20	90	3.5	90	M5	74	41	72	47	8, 9, 10, 11, 12, 14
EBH03/10	334	70	20	85	3.5	90	M6	74	41	72	47	8, 9, 10, 11, 12, 14
EBH03/11	334	70	20	90	3.5	90	M5	74	41	72	47	8, 9, 10, 11, 12, 14
EBH03/13	334	80	20	100	3.5	90	M6	74	41	72	47	8, 9, 10, 11, 12, 14
EBH03/14	334	95	16	115	4.0	105	M8	74	41	72	55	8, 9, 10, 11, 12, 14
EBH04/12	334	70	20	90	3.5	90	M6	74	41	72	47	14, 16, 19
EBH04/13	334	80	20	100	3.5	90	M6	74	41	72	47	14, 16, 19
EBH04/14	334	95	16	115	4.0	105	M8	74	41	72	55	14, 16, 19
EBH04/15	334	95	16	130	4.0	115	M8	74	41	72	60	14, 16, 19
EBH05/14	361	95	16	115	5.0	120	M8	101	56	72	62	14, 16, 17, 18, 19, 24
EBH05/15	361	95	16	130	5.0	120	M8	101	56	72	62	14, 16, 17, 18, 19, 24
EBH05/16	361	110	16	130	5.0	120	M8	101	56	72	62	14, 16, 17, 18, 19, 24
EBH05/17	361	110	16	145	5.0	120	M8	101	56	72	62	14, 16, 17, 18, 19, 24
EBH05/18	361	110	20	165	5.0	140	M10	101	56	72	72	14, 16, 17, 18, 19, 24
EBH05/20	361	130	20	165	5.0	140	M10	101	56	72	72	14, 16, 17, 18, 19, 24
EBH06/19	400	114	24	200	5.0	174	M12	140	86	72	89	35
EBH07/20	380	130	24	165	5.0	155	M10	120	66	72	80	22, 24, 28, 32
EBH07/21	380	130	24	215	5.0	190	M12	120	66	72	97	22, 24, 28, 32
EBH07/22	380	180	24	215	5.0	190	M12	120	66	72	97	22, 24, 28, 32
EBH08/22	399	180	24	215	5.0	190	M12	139	82	72	97	32, 35, 38

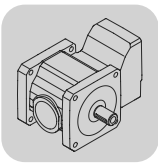
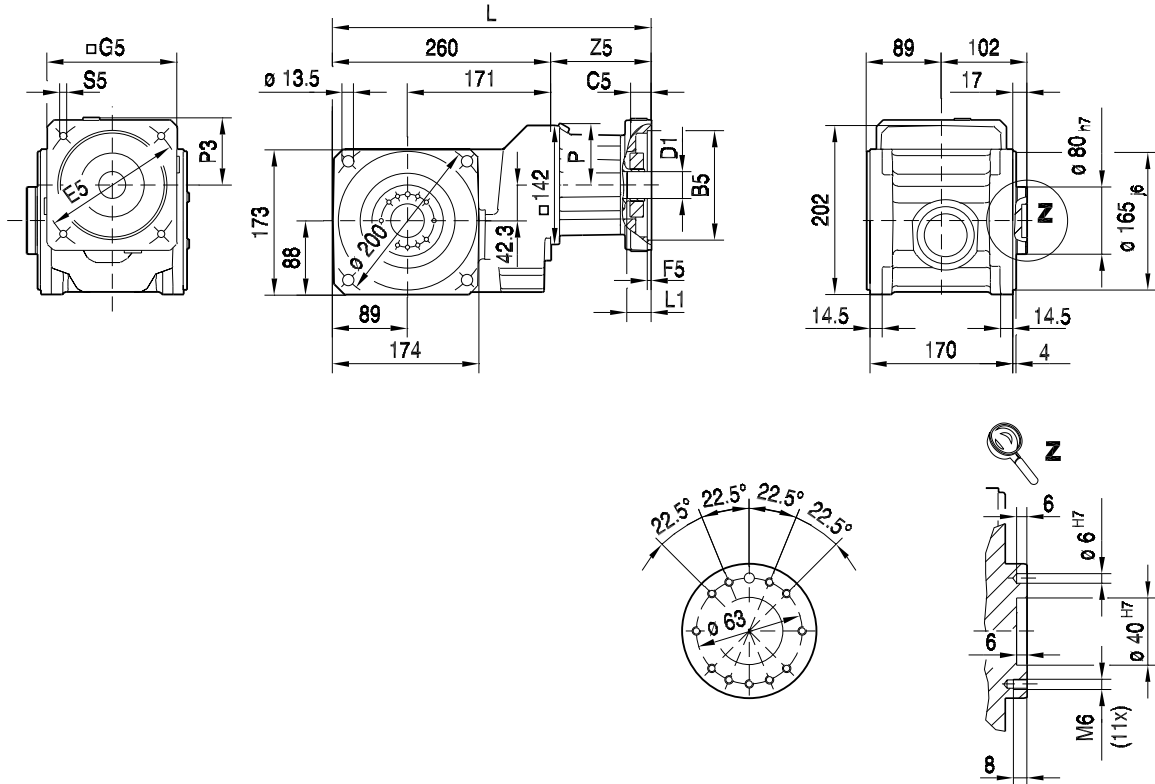
BSBF502..
55 013 00 03

(→ 90°)	L	B5	C5	E5	F5	G5	S5	Z5	L1	P	P3	D1
EBH03/03	334	50	20	60	3.5	90	M4	74	41	72	47	8, 9, 10, 11, 12, 14
EBH03/04	334	50	20	70	3.5	90	M5	74	41	72	47	8, 9, 10, 11, 12, 14
EBH03/05	334	50	20	80	3.5	90	M4	74	41	72	47	8, 9, 10, 11, 12, 14
EBH03/06	334	50	20	95	3.5	90	M6	74	41	72	47	8, 9, 10, 11, 12, 14
EBH03/07	334	50	20	100	3.5	90	M6	74	41	72	47	8, 9, 10, 11, 12, 14
EBH03/08	334	60	20	75	3.5	90	M5	74	41	72	47	8, 9, 10, 11, 12, 14
EBH03/09	334	60	20	90	3.5	90	M5	74	41	72	47	8, 9, 10, 11, 12, 14
EBH03/10	334	70	20	85	3.5	90	M6	74	41	72	47	8, 9, 10, 11, 12, 14
EBH03/11	334	70	20	90	3.5	90	M5	74	41	72	47	8, 9, 10, 11, 12, 14
EBH03/13	334	80	20	100	3.5	90	M6	74	41	72	47	8, 9, 10, 11, 12, 14
EBH03/14	334	95	16	115	4.0	105	M8	74	41	72	55	8, 9, 10, 11, 12, 14
EBH04/12	334	70	20	90	3.5	90	M6	74	41	72	47	14, 16, 19
EBH04/13	334	80	20	100	3.5	90	M6	74	41	72	47	14, 16, 19
EBH04/14	334	95	16	115	4.0	105	M8	74	41	72	55	14, 16, 19
EBH04/15	334	95	16	130	4.0	115	M8	74	41	72	60	14, 16, 19
EBH05/14	361	95	16	115	5.0	120	M8	101	56	72	62	14, 16, 17, 18, 19, 24
EBH05/15	361	95	16	130	5.0	120	M8	101	56	72	62	14, 16, 17, 18, 19, 24
EBH05/16	361	110	16	130	5.0	120	M8	101	56	72	62	14, 16, 17, 18, 19, 24
EBH05/17	361	110	16	145	5.0	120	M8	101	56	72	62	14, 16, 17, 18, 19, 24
EBH05/18	361	110	20	165	5.0	140	M10	101	56	72	72	14, 16, 17, 18, 19, 24
EBH05/20	361	130	20	165	5.0	140	M10	101	56	72	72	14, 16, 17, 18, 19, 24
EBH06/19	400	114	24	200	5.0	174	M12	140	86	72	89	35
EBH07/20	380	130	24	165	5.0	155	M10	120	66	72	80	22, 24, 28, 32
EBH07/21	380	130	24	215	5.0	190	M12	120	66	72	97	22, 24, 28, 32
EBH07/22	380	180	24	215	5.0	190	M12	120	66	72	97	22, 24, 28, 32
EBH08/22	399	180	24	215	5.0	190	M12	139	82	72	97	32, 35, 38

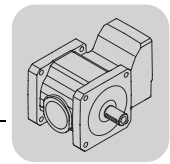

BSHF502..

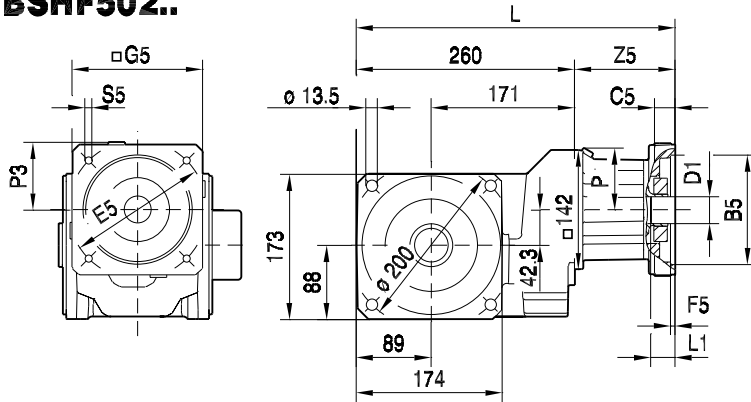

55 027 00 03

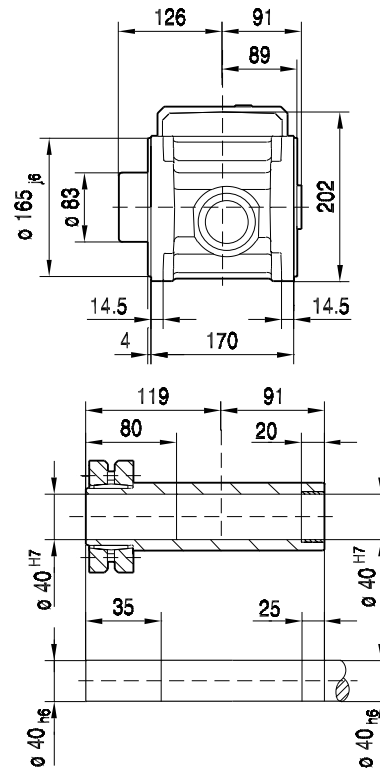

(→ 90)	L	B5	C5	E5	F5	G5	S5	Z5	L1	P	P3	D1
EBH03/03	334	50	20	60	3.5	90	M4	74	41	72	47	8, 9, 10, 11, 12, 14
EBH03/04	334	50	20	70	3.5	90	M5	74	41	72	47	8, 9, 10, 11, 12, 14
EBH03/05	334	50	20	80	3.5	90	M4	74	41	72	47	8, 9, 10, 11, 12, 14
EBH03/06	334	50	20	95	3.5	90	M6	74	41	72	47	8, 9, 10, 11, 12, 14
EBH03/07	334	50	20	100	3.5	90	M6	74	41	72	47	8, 9, 10, 11, 12, 14
EBH03/08	334	60	20	75	3.5	90	M5	74	41	72	47	8, 9, 10, 11, 12, 14
EBH03/09	334	60	20	90	3.5	90	M5	74	41	72	47	8, 9, 10, 11, 12, 14
EBH03/10	334	70	20	85	3.5	90	M6	74	41	72	47	8, 9, 10, 11, 12, 14
EBH03/11	334	70	20	90	3.5	90	M5	74	41	72	47	8, 9, 10, 11, 12, 14
EBH03/13	334	80	20	100	3.5	90	M6	74	41	72	47	8, 9, 10, 11, 12, 14
EBH03/14	334	95	16	115	4.0	105	M8	74	41	72	55	8, 9, 10, 11, 12, 14
EBH04/12	334	70	20	90	3.5	90	M6	74	41	72	47	14, 16, 19
EBH04/13	334	80	20	100	3.5	90	M6	74	41	72	47	14, 16, 19
EBH04/14	334	95	16	115	4.0	105	M8	74	41	72	55	14, 16, 19
EBH04/15	334	95	16	130	4.0	115	M8	74	41	72	60	14, 16, 19
EBH05/14	361	95	16	115	5.0	120	M8	101	56	72	62	14, 16, 17, 18, 19, 24
EBH05/15	361	95	16	130	5.0	120	M8	101	56	72	62	14, 16, 17, 18, 19, 24
EBH05/16	361	110	16	130	5.0	120	M8	101	56	72	62	14, 16, 17, 18, 19, 24
EBH05/17	361	110	16	145	5.0	120	M8	101	56	72	62	14, 16, 17, 18, 19, 24
EBH05/18	361	110	20	165	5.0	140	M10	101	56	72	72	14, 16, 17, 18, 19, 24
EBH05/20	361	130	20	165	5.0	140	M10	101	56	72	72	14, 16, 17, 18, 19, 24
EBH06/19	400	114	24	200	5.0	174	M12	140	86	72	89	35
EBH07/20	380	130	24	165	5.0	155	M10	120	66	72	80	22, 24, 28, 32
EBH07/21	380	130	24	215	5.0	190	M12	120	66	72	97	22, 24, 28, 32
EBH07/22	380	180	24	215	5.0	190	M12	120	66	72	97	22, 24, 28, 32
EBH08/22	399	180	24	215	5.0	190	M12	139	82	72	97	32, 35, 38

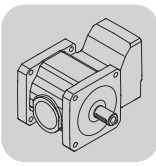

BSF..
BS.. EBH.. [mm]

BSHF502/I..

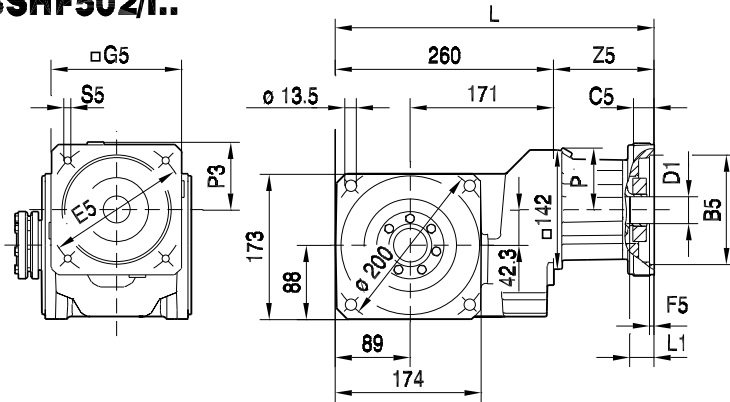

55 014 00 03

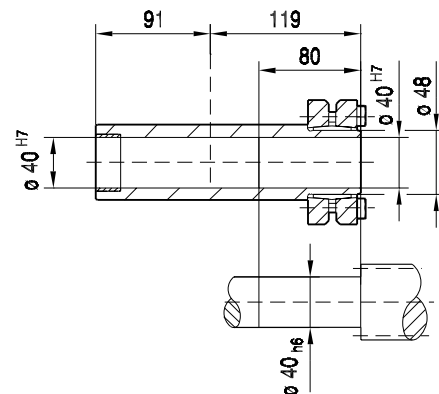
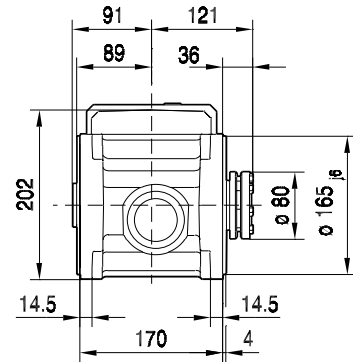

(→ 90)	L	B5	C5	E5	F5	G5	S5	Z5	L1	P	P3	D1
EBH03/03	334	50	20	60	3.5	90	M4	74	41	72	47	8, 9, 10, 11, 12, 14
EBH03/04	334	50	20	70	3.5	90	M5	74	41	72	47	8, 9, 10, 11, 12, 14
EBH03/05	334	50	20	80	3.5	90	M4	74	41	72	47	8, 9, 10, 11, 12, 14
EBH03/06	334	50	20	95	3.5	90	M6	74	41	72	47	8, 9, 10, 11, 12, 14
EBH03/07	334	50	20	100	3.5	90	M6	74	41	72	47	8, 9, 10, 11, 12, 14
EBH03/08	334	60	20	75	3.5	90	M5	74	41	72	47	8, 9, 10, 11, 12, 14
EBH03/09	334	60	20	90	3.5	90	M5	74	41	72	47	8, 9, 10, 11, 12, 14
EBH03/10	334	70	20	85	3.5	90	M6	74	41	72	47	8, 9, 10, 11, 12, 14
EBH03/11	334	70	20	90	3.5	90	M5	74	41	72	47	8, 9, 10, 11, 12, 14
EBH03/13	334	80	20	100	3.5	90	M6	74	41	72	47	8, 9, 10, 11, 12, 14
EBH03/14	334	95	16	115	4.0	105	M8	74	41	72	55	8, 9, 10, 11, 12, 14
EBH04/12	334	70	20	90	3.5	90	M6	74	41	72	47	14, 16, 19
EBH04/13	334	80	20	100	3.5	90	M6	74	41	72	47	14, 16, 19
EBH04/14	334	95	16	115	4.0	105	M8	74	41	72	55	14, 16, 19
EBH04/15	334	95	16	130	4.0	115	M8	74	41	72	60	14, 16, 19
EBH05/14	361	95	16	115	5.0	120	M8	101	56	72	62	14, 16, 17, 18, 19, 24
EBH05/15	361	95	16	130	5.0	120	M8	101	56	72	62	14, 16, 17, 18, 19, 24
EBH05/16	361	110	16	130	5.0	120	M8	101	56	72	62	14, 16, 17, 18, 19, 24
EBH05/17	361	110	16	145	5.0	120	M8	101	56	72	62	14, 16, 17, 18, 19, 24
EBH05/18	361	110	20	165	5.0	140	M10	101	56	72	72	14, 16, 17, 18, 19, 24
EBH05/20	361	130	20	165	5.0	140	M10	101	56	72	72	14, 16, 17, 18, 19, 24
EBH06/19	400	114	24	200	5.0	174	M12	140	86	72	89	35
EBH07/20	380	130	24	165	5.0	155	M10	120	66	72	80	22, 24, 28, 32
EBH07/21	380	130	24	215	5.0	190	M12	120	66	72	97	22, 24, 28, 32
EBH07/22	380	180	24	215	5.0	190	M12	120	66	72	97	22, 24, 28, 32
EBH08/22	399	180	24	215	5.0	190	M12	139	82	72	97	32, 35, 38

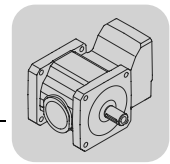

BSF602..

55 015 00 03

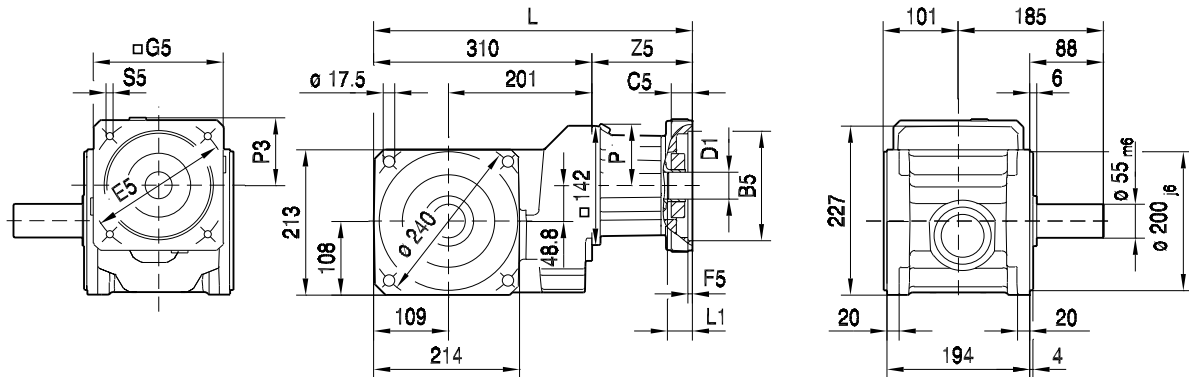

BSKF

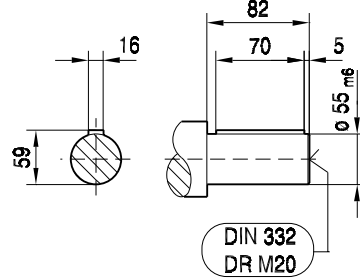

BSF

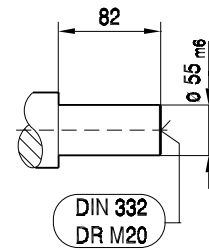

(→ 90°)	L	B5	C5	E5	F5	G5	S5	Z5	L1	P	P3	D1
EBH03/03	384	50	20	60	3.5	90	M4	74	41	72	47	8, 9, 10, 11, 12, 14
EBH03/04	384	50	20	70	3.5	90	M5	74	41	72	47	8, 9, 10, 11, 12, 14
EBH03/05	384	50	20	80	3.5	90	M4	74	41	72	47	8, 9, 10, 11, 12, 14
EBH03/06	384	50	20	95	3.5	90	M6	74	41	72	47	8, 9, 10, 11, 12, 14
EBH03/07	384	50	20	100	3.5	90	M6	74	41	72	47	8, 9, 10, 11, 12, 14
EBH03/08	384	60	20	75	3.5	90	M5	74	41	72	47	8, 9, 10, 11, 12, 14
EBH03/09	384	60	20	90	3.5	90	M5	74	41	72	47	8, 9, 10, 11, 12, 14
EBH03/10	384	70	20	85	3.5	90	M6	74	41	72	47	8, 9, 10, 11, 12, 14
EBH03/11	384	70	20	90	3.5	90	M5	74	41	72	47	8, 9, 10, 11, 12, 14
EBH03/13	384	80	20	100	3.5	90	M6	74	41	72	47	8, 9, 10, 11, 12, 14
EBH03/14	384	95	16	115	4.0	105	M8	74	41	72	55	8, 9, 10, 11, 12, 14
EBH04/12	384	70	20	90	3.5	90	M6	74	41	72	47	14, 16, 19
EBH04/13	384	80	20	100	3.5	90	M6	74	41	72	47	14, 16, 19
EBH04/14	384	95	16	115	4.0	105	M8	74	41	72	55	14, 16, 19
EBH04/15	384	95	16	130	4.0	115	M8	74	41	72	60	14, 16, 19
EBH05/14	411	95	16	115	5.0	120	M8	101	56	72	62	14, 16, 17, 18, 19, 24
EBH05/15	411	95	16	130	5.0	120	M8	101	56	72	62	14, 16, 17, 18, 19, 24
EBH05/16	411	110	16	130	5.0	120	M8	101	56	72	62	14, 16, 17, 18, 19, 24
EBH05/17	411	110	16	145	5.0	120	M8	101	56	72	62	14, 16, 17, 18, 19, 24
EBH05/18	411	110	20	165	5.0	140	M10	101	56	72	72	14, 16, 17, 18, 19, 24
EBH05/20	411	130	20	165	5.0	140	M10	101	56	72	72	14, 16, 17, 18, 19, 24
EBH06/19	450	114	24	200	5.0	174	M12	140	86	72	89	35
EBH07/20	430	130	24	165	5.0	155	M10	120	66	72	80	22, 24, 28, 32
EBH07/21	430	130	24	215	5.0	190	M12	120	66	72	97	22, 24, 28, 32
EBH07/22	430	180	24	215	5.0	190	M12	120	66	72	97	22, 24, 28, 32
EBH08/22	449	180	24	215	5.0	190	M12	139	82	72	97	32, 35, 38

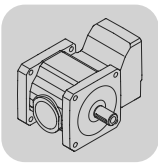
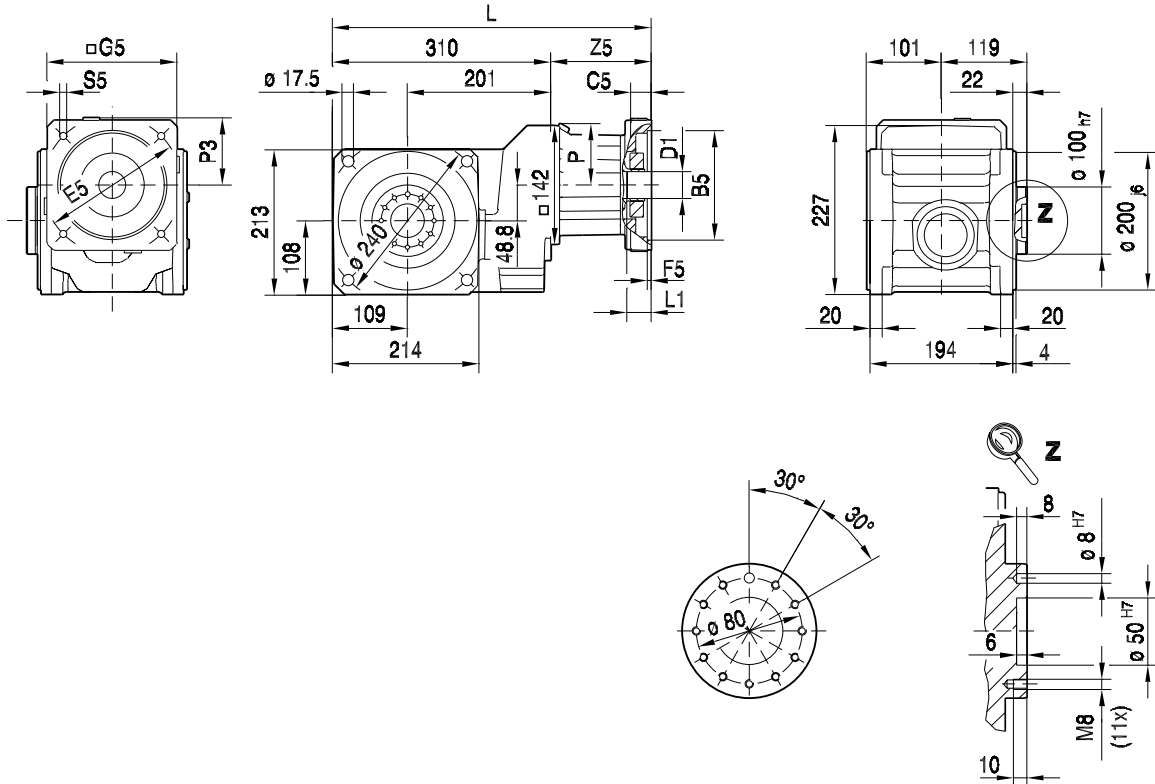
BSBF602..
55 016 00 03

(→ 90°)	L	B5	C5	E5	F5	G5	S5	Z5	L1	P	P3	D1
EBH03/03	384	50	20	60	3.5	90	M4	74	41	72	47	8, 9, 10, 11, 12, 14
EBH03/04	384	50	20	70	3.5	90	M5	74	41	72	47	8, 9, 10, 11, 12, 14
EBH03/05	384	50	20	80	3.5	90	M4	74	41	72	47	8, 9, 10, 11, 12, 14
EBH03/06	384	50	20	95	3.5	90	M6	74	41	72	47	8, 9, 10, 11, 12, 14
EBH03/07	384	50	20	100	3.5	90	M6	74	41	72	47	8, 9, 10, 11, 12, 14
EBH03/08	384	60	20	75	3.5	90	M5	74	41	72	47	8, 9, 10, 11, 12, 14
EBH03/09	384	60	20	90	3.5	90	M5	74	41	72	47	8, 9, 10, 11, 12, 14
EBH03/10	384	70	20	85	3.5	90	M6	74	41	72	47	8, 9, 10, 11, 12, 14
EBH03/11	384	70	20	90	3.5	90	M5	74	41	72	47	8, 9, 10, 11, 12, 14
EBH03/13	384	80	20	100	3.5	90	M6	74	41	72	47	8, 9, 10, 11, 12, 14
EBH03/14	384	95	16	115	4.0	105	M8	74	41	72	55	8, 9, 10, 11, 12, 14
EBH04/12	384	70	20	90	3.5	90	M6	74	41	72	47	14, 16, 19
EBH04/13	384	80	20	100	3.5	90	M6	74	41	72	47	14, 16, 19
EBH04/14	384	95	16	115	4.0	105	M8	74	41	72	55	14, 16, 19
EBH04/15	384	95	16	130	4.0	115	M8	74	41	72	60	14, 16, 19
EBH05/14	411	95	16	115	5.0	120	M8	101	56	72	62	14, 16, 17, 18, 19, 24
EBH05/15	411	95	16	130	5.0	120	M8	101	56	72	62	14, 16, 17, 18, 19, 24
EBH05/16	411	110	16	130	5.0	120	M8	101	56	72	62	14, 16, 17, 18, 19, 24
EBH05/17	411	110	16	145	5.0	120	M8	101	56	72	62	14, 16, 17, 18, 19, 24
EBH05/18	411	110	20	165	5.0	140	M10	101	56	72	72	14, 16, 17, 18, 19, 24
EBH05/20	411	130	20	165	5.0	140	M10	101	56	72	72	14, 16, 17, 18, 19, 24
EBH06/19	450	114	24	200	5.0	174	M12	140	86	72	89	35
EBH07/20	430	130	24	165	5.0	155	M10	120	66	72	80	22, 24, 28, 32
EBH07/21	430	130	24	215	5.0	190	M12	120	66	72	97	22, 24, 28, 32
EBH07/22	430	180	24	215	5.0	190	M12	120	66	72	97	22, 24, 28, 32
EBH08/22	449	180	24	215	5.0	190	M12	139	82	72	97	32, 35, 38

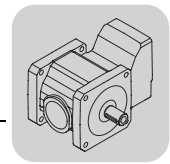

BSHF602..

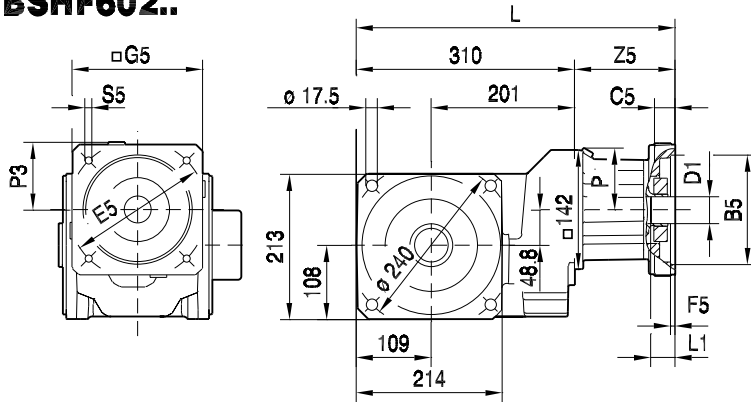

55 029 00 03

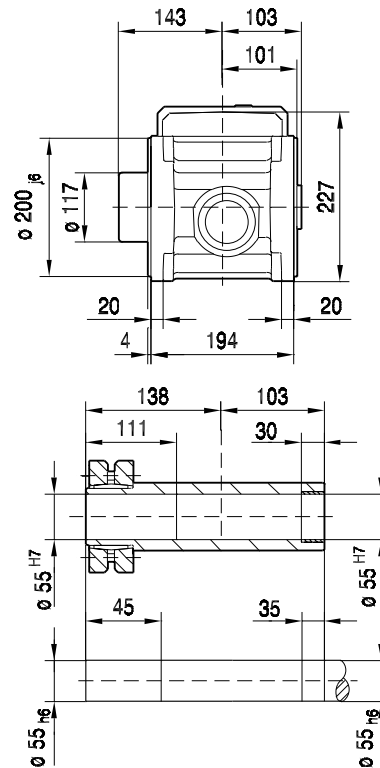

(→ 90)	L	B5	C5	E5	F5	G5	S5	Z5	L1	P	P3	D1
EBH03/03	384	50	20	60	3.5	90	M4	74	41	72	47	8, 9, 10, 11, 12, 14
EBH03/04	384	50	20	70	3.5	90	M5	74	41	72	47	8, 9, 10, 11, 12, 14
EBH03/05	384	50	20	80	3.5	90	M4	74	41	72	47	8, 9, 10, 11, 12, 14
EBH03/06	384	50	20	95	3.5	90	M6	74	41	72	47	8, 9, 10, 11, 12, 14
EBH03/07	384	50	20	100	3.5	90	M6	74	41	72	47	8, 9, 10, 11, 12, 14
EBH03/08	384	60	20	75	3.5	90	M5	74	41	72	47	8, 9, 10, 11, 12, 14
EBH03/09	384	60	20	90	3.5	90	M5	74	41	72	47	8, 9, 10, 11, 12, 14
EBH03/10	384	70	20	85	3.5	90	M6	74	41	72	47	8, 9, 10, 11, 12, 14
EBH03/11	384	70	20	90	3.5	90	M5	74	41	72	47	8, 9, 10, 11, 12, 14
EBH03/13	384	80	20	100	3.5	90	M6	74	41	72	47	8, 9, 10, 11, 12, 14
EBH03/14	384	95	16	115	4.0	105	M8	74	41	72	55	8, 9, 10, 11, 12, 14
EBH04/12	384	70	20	90	3.5	90	M6	74	41	72	47	14, 16, 19
EBH04/13	384	80	20	100	3.5	90	M6	74	41	72	47	14, 16, 19
EBH04/14	384	95	16	115	4.0	105	M8	74	41	72	55	14, 16, 19
EBH04/15	384	95	16	130	4.0	115	M8	74	41	72	60	14, 16, 19
EBH05/14	411	95	16	115	5.0	120	M8	101	56	72	62	14, 16, 17, 18, 19, 24
EBH05/15	411	95	16	130	5.0	120	M8	101	56	72	62	14, 16, 17, 18, 19, 24
EBH05/16	411	110	16	130	5.0	120	M8	101	56	72	62	14, 16, 17, 18, 19, 24
EBH05/17	411	110	16	145	5.0	120	M8	101	56	72	62	14, 16, 17, 18, 19, 24
EBH05/18	411	110	20	165	5.0	140	M10	101	56	72	72	14, 16, 17, 18, 19, 24
EBH05/20	411	130	20	165	5.0	140	M10	101	56	72	72	14, 16, 17, 18, 19, 24
EBH06/19	450	114	24	200	5.0	174	M12	140	86	72	89	35
EBH07/20	430	130	24	165	5.0	155	M10	120	66	72	80	22, 24, 28, 32
EBH07/21	430	130	24	215	5.0	190	M12	120	66	72	97	22, 24, 28, 32
EBH07/22	430	180	24	215	5.0	190	M12	120	66	72	97	22, 24, 28, 32
EBH08/22	449	180	24	215	5.0	190	M12	139	82	72	97	32, 35, 38

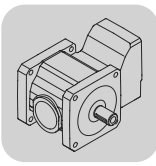

BSF..
BS.. EBH.. [mm]

BSHF602/I..

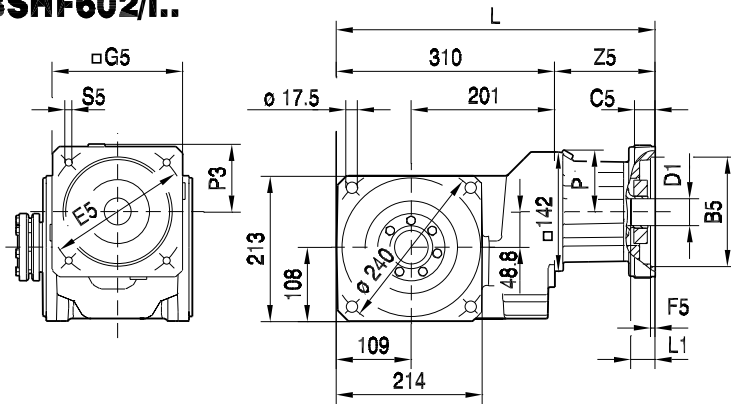

55 017 00 03

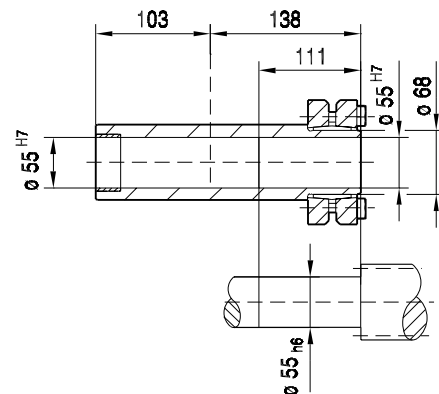
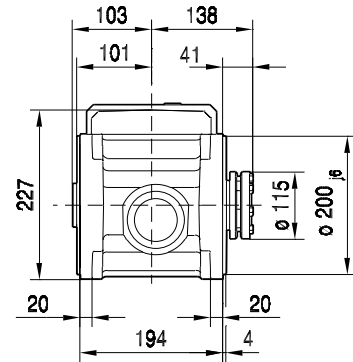

(→ 90)	L	B5	C5	E5	F5	G5	S5	Z5	L1	P	P3	D1
EBH03/03	384	50	20	60	3.5	90	M4	74	41	72	47	8, 9, 10, 11, 12, 14
EBH03/04	384	50	20	70	3.5	90	M5	74	41	72	47	8, 9, 10, 11, 12, 14
EBH03/05	384	50	20	80	3.5	90	M4	74	41	72	47	8, 9, 10, 11, 12, 14
EBH03/06	384	50	20	95	3.5	90	M6	74	41	72	47	8, 9, 10, 11, 12, 14
EBH03/07	384	50	20	100	3.5	90	M6	74	41	72	47	8, 9, 10, 11, 12, 14
EBH03/08	384	60	20	75	3.5	90	M5	74	41	72	47	8, 9, 10, 11, 12, 14
EBH03/09	384	60	20	90	3.5	90	M5	74	41	72	47	8, 9, 10, 11, 12, 14
EBH03/10	384	70	20	85	3.5	90	M6	74	41	72	47	8, 9, 10, 11, 12, 14
EBH03/11	384	70	20	90	3.5	90	M5	74	41	72	47	8, 9, 10, 11, 12, 14
EBH03/13	384	80	20	100	3.5	90	M6	74	41	72	47	8, 9, 10, 11, 12, 14
EBH03/14	384	95	16	115	4.0	105	M8	74	41	72	55	8, 9, 10, 11, 12, 14
EBH04/12	384	70	20	90	3.5	90	M6	74	41	72	47	14, 16, 19
EBH04/13	384	80	20	100	3.5	90	M6	74	41	72	47	14, 16, 19
EBH04/14	384	95	16	115	4.0	105	M8	74	41	72	55	14, 16, 19
EBH04/15	384	95	16	130	4.0	115	M8	74	41	72	60	14, 16, 19
EBH05/14	411	95	16	115	5.0	120	M8	101	56	72	62	14, 16, 17, 18, 19, 24
EBH05/15	411	95	16	130	5.0	120	M8	101	56	72	62	14, 16, 17, 18, 19, 24
EBH05/16	411	110	16	130	5.0	120	M8	101	56	72	62	14, 16, 17, 18, 19, 24
EBH05/17	411	110	16	145	5.0	120	M8	101	56	72	62	14, 16, 17, 18, 19, 24
EBH05/18	411	110	20	165	5.0	140	M10	101	56	72	72	14, 16, 17, 18, 19, 24
EBH05/20	411	130	20	165	5.0	140	M10	101	56	72	72	14, 16, 17, 18, 19, 24
EBH06/19	450	114	24	200	5.0	174	M12	140	86	72	89	35
EBH07/20	430	130	24	165	5.0	155	M10	120	66	72	80	22, 24, 28, 32
EBH07/21	430	130	24	215	5.0	190	M12	120	66	72	97	22, 24, 28, 32
EBH07/22	430	180	24	215	5.0	190	M12	120	66	72	97	22, 24, 28, 32
EBH08/22	449	180	24	215	5.0	190	M12	139	82	72	97	32, 35, 38

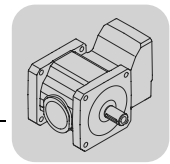

BSF802..

55 018 00 03

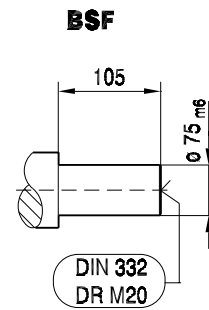
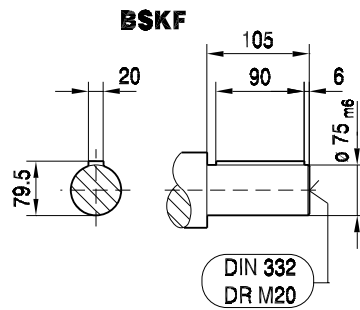
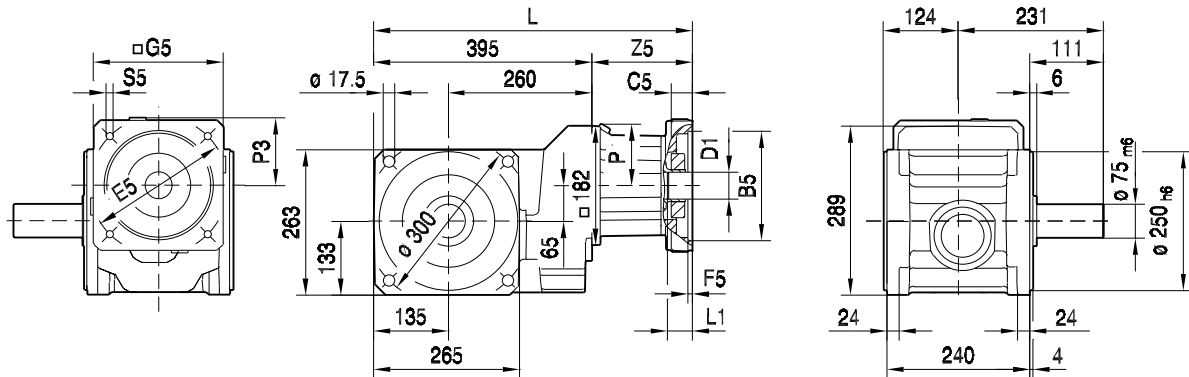

(→ 90)	L	B5	C5	E5	F5	G5	S5	Z5	L1	P	P3	D1
EBH05/14	492	95	16	115	5.0	120	M8	97	56	92	62	14, 16, 17, 18, 19, 24
EBH05/15	492	95	16	130	5.0	120	M8	97	56	92	62	14, 16, 17, 18, 19, 24
EBH05/16	492	110	16	130	5.0	120	M8	97	56	92	62	14, 16, 17, 18, 19, 24
EBH05/17	492	110	16	145	5.0	120	M8	97	56	92	62	14, 16, 17, 18, 19, 24
EBH05/18	492	110	20	165	5.0	140	M10	97	56	92	72	14, 16, 17, 18, 19, 24
EBH05/20	492	130	20	165	5.0	140	M10	97	56	92	72	14, 16, 17, 18, 19, 24
EBH06/19	531	114	24	200	5.0	174	M12	136	86	92	89	35
EBH07/20	511	130	24	165	5.0	155	M10	116	66	92	80	22, 24, 28, 32
EBH07/21	511	130	24	215	5.0	190	M12	116	66	92	97	22, 24, 28, 32
EBH07/22	511	180	24	215	5.0	190	M12	116	66	92	97	22, 24, 28, 32
EBH08/22	530	180	24	215	5.0	190	M12	135	82	92	97	32, 35, 38
EBH09/22	554	180	23	215	6.0	190	M12	159	86	92	97	32, 35, 38, 42
EBH09/23	584	230	53	265	5.0	240	M12	189	116	92	122	32, 35, 38, 42
EBH09/24	584	250	53	300	6.0	260	M16	189	116	92	132	32, 35, 38, 42
EBH10/24	584	250	53	300	6.0	260	M16	189	116	92	132	48
EBH10/25	584	300	53	350	6.0	310	M16	189	116	92	157	48

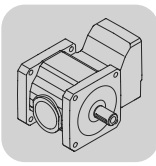
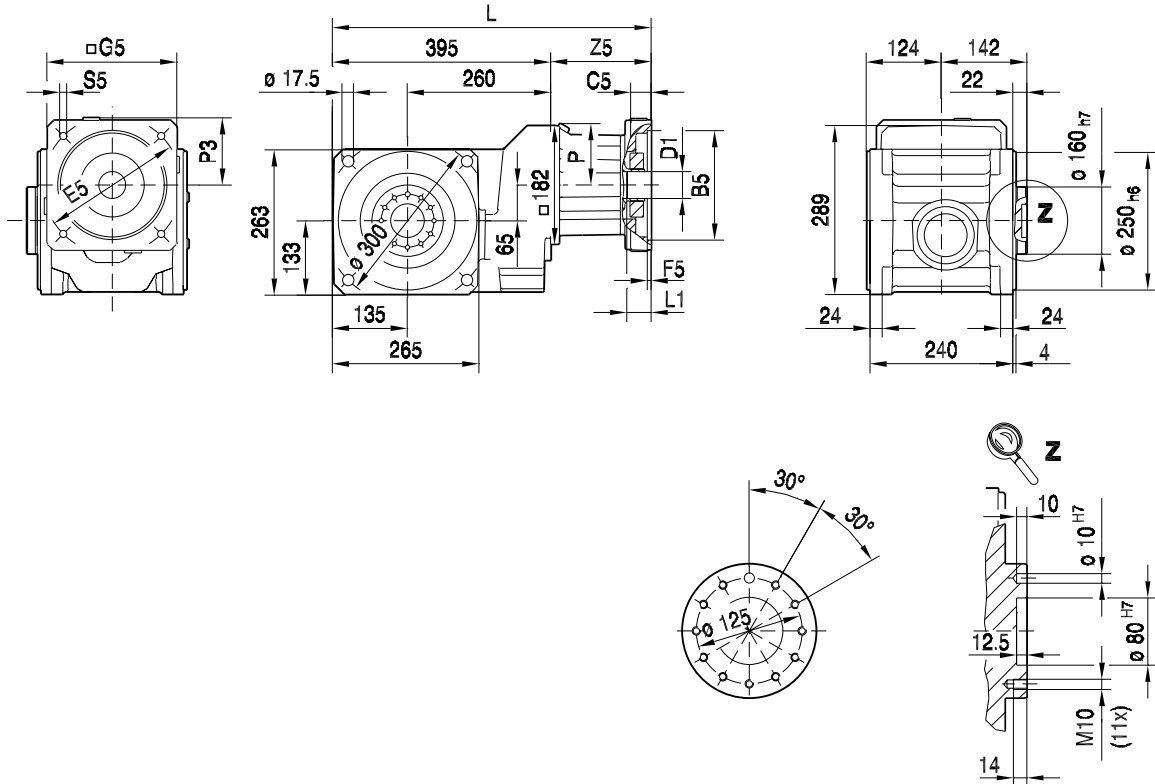
BSBF802..
55 019 00 03

(→ 90)	L	B5	C5	E5	F5	G5	S5	Z5	L1	P	P3	D1
EBH05/14	492	95	16	115	5.0	120	M8	97	56	92	62	14, 16, 17, 18, 19, 24
EBH05/15	492	95	16	130	5.0	120	M8	97	56	92	62	14, 16, 17, 18, 19, 24
EBH05/16	492	110	16	130	5.0	120	M8	97	56	92	62	14, 16, 17, 18, 19, 24
EBH05/17	492	110	16	145	5.0	120	M8	97	56	92	62	14, 16, 17, 18, 19, 24
EBH05/18	492	110	20	165	5.0	140	M10	97	56	92	72	14, 16, 17, 18, 19, 24
EBH05/20	492	130	20	165	5.0	140	M10	97	56	92	72	14, 16, 17, 18, 19, 24
EBH06/19	531	114	24	200	5.0	174	M12	136	86	92	89	35
EBH07/20	511	130	24	165	5.0	155	M10	116	66	92	80	22, 24, 28, 32
EBH07/21	511	130	24	215	5.0	190	M12	116	66	92	97	22, 24, 28, 32
EBH07/22	511	180	24	215	5.0	190	M12	116	66	92	97	22, 24, 28, 32
EBH08/22	530	180	24	215	5.0	190	M12	135	82	92	97	32, 35, 38
EBH09/22	554	180	23	215	6.0	190	M12	159	86	92	97	32, 35, 38, 42
EBH09/23	584	230	53	265	5.0	240	M12	189	116	92	122	32, 35, 38, 42
EBH09/24	584	250	53	300	6.0	260	M16	189	116	92	132	32, 35, 38, 42
EBH10/24	584	250	53	300	6.0	260	M16	189	116	92	132	48
EBH10/25	584	300	53	350	6.0	310	M16	189	116	92	157	48

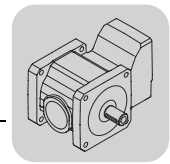

BSHF802..

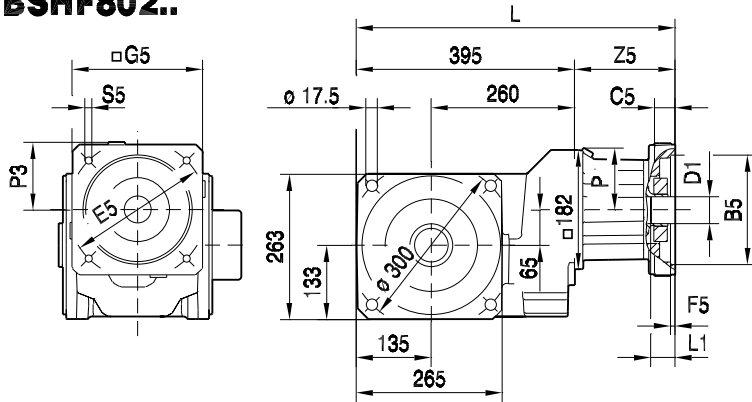

55 031 00 03

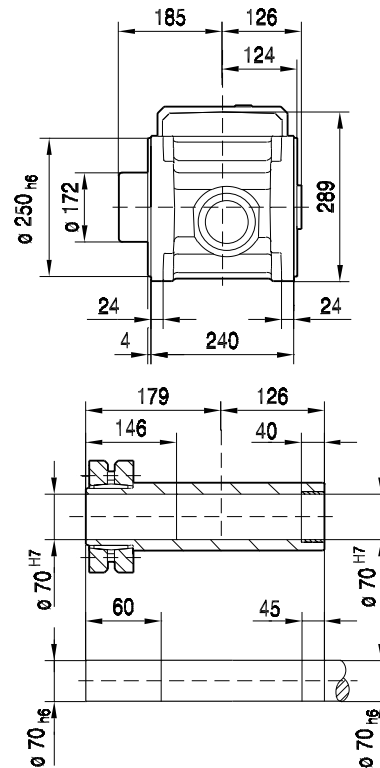

(→ 90)	L	B5	C5	E5	F5	G5	S5	Z5	L1	P	P3	D1
EBH05/14	492	95	16	115	5.0	120	M8	97	56	92	62	14, 16, 17, 18, 19, 24
EBH05/15	492	95	16	130	5.0	120	M8	97	56	92	62	14, 16, 17, 18, 19, 24
EBH05/16	492	110	16	130	5.0	120	M8	97	56	92	62	14, 16, 17, 18, 19, 24
EBH05/17	492	110	16	145	5.0	120	M8	97	56	92	62	14, 16, 17, 18, 19, 24
EBH05/18	492	110	20	165	5.0	140	M10	97	56	92	72	14, 16, 17, 18, 19, 24
EBH05/20	492	130	20	165	5.0	140	M10	97	56	92	72	14, 16, 17, 18, 19, 24
EBH06/19	531	114	24	200	5.0	174	M12	136	86	92	89	35
EBH07/20	511	130	24	165	5.0	155	M10	116	66	92	80	22, 24, 28, 32
EBH07/21	511	130	24	215	5.0	190	M12	116	66	92	97	22, 24, 28, 32
EBH07/22	511	180	24	215	5.0	190	M12	116	66	92	97	22, 24, 28, 32
EBH08/22	530	180	24	215	5.0	190	M12	135	82	92	97	32, 35, 38
EBH09/22	554	180	23	215	6.0	190	M12	159	86	92	97	32, 35, 38, 42
EBH09/23	584	230	53	265	5.0	240	M12	189	116	92	122	32, 35, 38, 42
EBH09/24	584	250	53	300	6.0	260	M16	189	116	92	132	32, 35, 38, 42
EBH10/24	584	250	53	300	6.0	260	M16	189	116	92	132	48
EBH10/25	584	300	53	350	6.0	310	M16	189	116	92	157	48

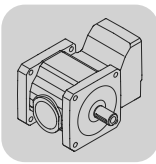

BSF..
BS.. EBH.. [mm]

BSHF802/I..

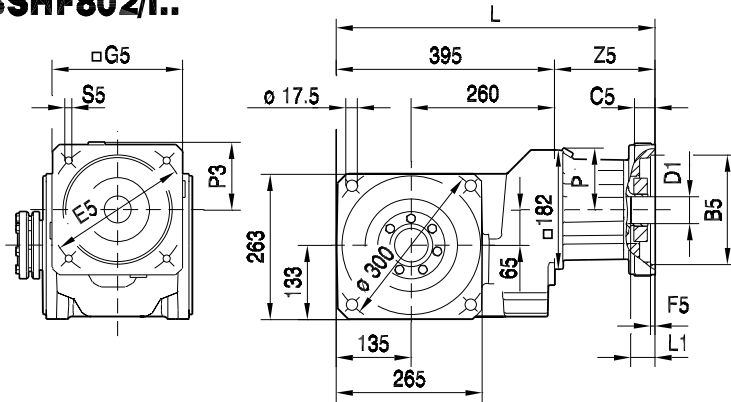

55 020 00 03

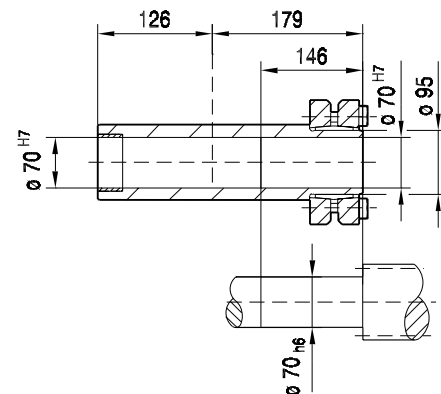
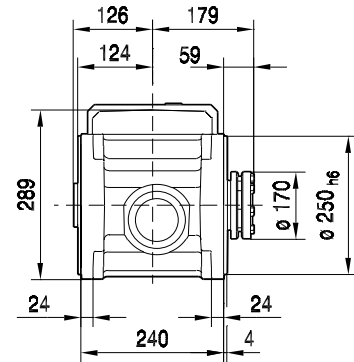

(→ 90)	L	B5	C5	E5	F5	G5	S5	Z5	L1	P	P3	D1
EBH05/14	492	95	16	115	5.0	120	M8	97	56	92	62	14, 16, 17, 18, 19, 24
EBH05/15	492	95	16	130	5.0	120	M8	97	56	92	62	14, 16, 17, 18, 19, 24
EBH05/16	492	110	16	130	5.0	120	M8	97	56	92	62	14, 16, 17, 18, 19, 24
EBH05/17	492	110	16	145	5.0	120	M8	97	56	92	62	14, 16, 17, 18, 19, 24
EBH05/18	492	110	20	165	5.0	140	M10	97	56	92	72	14, 16, 17, 18, 19, 24
EBH05/20	492	130	20	165	5.0	140	M10	97	56	92	72	14, 16, 17, 18, 19, 24
EBH06/19	531	114	24	200	5.0	174	M12	136	86	92	89	35
EBH07/20	511	130	24	165	5.0	155	M10	116	66	92	80	22, 24, 28, 32
EBH07/21	511	130	24	215	5.0	190	M12	116	66	92	97	22, 24, 28, 32
EBH07/22	511	180	24	215	5.0	190	M12	116	66	92	97	22, 24, 28, 32
EBH08/22	530	180	24	215	5.0	190	M12	135	82	92	97	32, 35, 38
EBH09/22	554	180	23	215	6.0	190	M12	159	86	92	97	32, 35, 38, 42
EBH09/23	584	230	53	265	5.0	240	M12	189	116	92	122	32, 35, 38, 42
EBH09/24	584	250	53	300	6.0	260	M16	189	116	92	132	32, 35, 38, 42
EBH10/24	584	250	53	300	6.0	260	M16	189	116	92	132	48
EBH10/25	584	300	53	350	6.0	310	M16	189	116	92	157	48

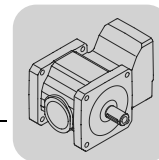

7.7 BS.. EBH.. → D1 [mm]

Kennzahl Bohrung								
D1	EBH03/./..	EBH04/./..	EBH05/./..	EBH06/./..	EBH07/./..	EBH08/./..	EBH09/./..	EBH10/./..
	BS..202	BS..202						
	BS..302	BS..302	BS..302					
	BS..402	BS..402	BS..402	BS..402	BS..402			
	BS..502	BS..502	BS..502	BS..502	BS..502	BS..502		
	BS..602	BS..602	BS..602	BS..602	BS..602	BS..602		
			BS..802	BS..802	BS..802	BS..802	BS..802	BS..802
55								20
48								19
42							18	
38						17	17	
35				16		16	16	
32					15	15	15	
28					14			
24			13		13			
22					12			
19		11	11					
18			10					
17			09					
16		08	08					
14	06	06	06					
12	05							
11	04							
10	03							
9	02							
8	01							