

MAX44000

Ambient and Infrared Proximity Sensor

General Description

The MAX44000 combines a wide-dynamic range ambient light sensor with an integrated infrared proximity sensor. The IC is a perfect solution for touch-screen portable devices.

The IC can consume as low as 11 μ A (time averaged) in ambient light sensing plus proximity sensing, including external IR LED current.

The on-chip ambient sensor has the ability to make wide dynamic range 0.03 lux to 65,535 lux measurements. An on-chip IR proximity detector is matched with an integrated IR LED driver. All readings are available on an I²C communication bus. A programmable interrupt pin minimizes the need to poll the device for data, freeing up microcontroller resources, reducing system software overhead, and ultimately, reducing power consumption.

The IC is designed to drive an external IR LED and can operate from a V_{DD} of 1.7V to 3.6V. It consumes just 5 μ A operating current when only the ambient light sensor is enabled and 7 μ A when the proximity receiver and driver are enabled.

Applications

Smartphones
Accessories
Industrial Sensors
Presence Detection

Features

- ◆ **Tiny, 2mm x 2mm x 0.6mm UTDFN-Opto Package**
- ◆ **V_{DD} = 1.7V to 3.6V**
- ◆ **Low-Power Operation**
 - 5 μ A in Ambient Mode
 - 7 μ A in Ambient Plus Proximity Mode
 - 70 μ A in Ambient Plus Proximity Mode, Including 100mA LED Current
- ◆ **Excellent Light Source Matching**
Programmable Green and IR Channel Gains
- ◆ **Integrated Single-Pulse IR LED Driver**
10mA to 110mA Programmable Range
Internal Ambient Cancellation
- ◆ **-40°C to +105°C Temperature Range**

Ordering Information

PART	TEMP RANGE	PIN-PACKAGE
MAX44000GDT+	-40°C to +105°C	6 OTDFN-EP*

+Denotes a lead(Pb)-free/RoHS-compliant package.

*EP = Exposed pad.

Typical Application Circuit appears at end of data sheet.

Simplified Block Diagram

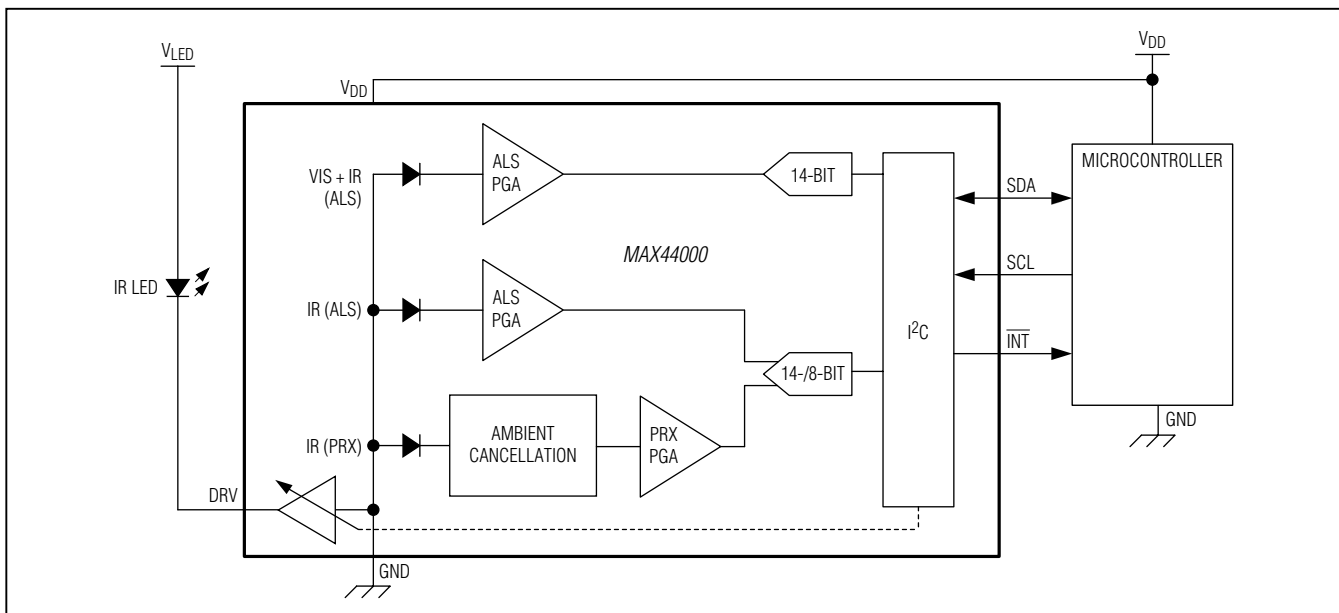

For pricing, delivery, and ordering information, please contact Maxim Direct at 1-888-629-4642, or visit Maxim's website at www.maximintegrated.com.

MAX44000

Ambient and Infrared Proximity Sensor

ABSOLUTE MAXIMUM RATINGS

All Pins to GND	-0.3V to +4.0V	Continuous Power Dissipation (T _A = +70°C)	
Output Short-Circuit Current Duration.....	Continuous	6-Pin OTDFN (derate 11.9mW/°C above +70°C)	953mW
Continuous Input Current into Any Terminal.....	±20mA	Operating Temperature Range	-40°C to +105°C
		Soldering Temperature (reflow)	+260°C

Stresses beyond those listed under "Absolute Maximum Ratings" may cause permanent damage to the device. These are stress ratings only, and functional operation of the device at these or any other conditions beyond those indicated in the operational sections of the specifications is not implied. Exposure to absolute maximum rating conditions for extended periods may affect device reliability.

ELECTRICAL CHARACTERISTICS

(V_{DD} = 1.8V, T_{MIN} – T_{MAX} = -40°C to +105°C, T_A = +25°C, unless otherwise noted.) (Note 1)

PARAMETER	SYMBOL	CONDITIONS	MIN	TYP	MAX	UNITS
AMBIENT LIGHT RECEIVER CHARACTERISTICS						
Maximum Ambient Light Sensitivity		Fluorescent light (Note 2)		0.03		Lux/LSB
Ambient Light Saturation Level				65,535		Lux
Gain Error		Green LED 538nm response, T _A = +25°C (Note 2)			15	%
Light Source Matching		Fluorescent/incandescent light		10		%
Infrared Transmittance		850nm vs. 538nm, T _A = +25°C		0.5		%
Ultraviolet Transmittance		363nm vs. 538nm, T _A = +25°C		2		%
Dark Current Level		100ms conversion time, 0 lux, T _A = +25°C		0		Count
ADC Conversion Time		14-bit resolution, has 50Hz/60Hz rejection		100		ms
		12-bit resolution		25		
		10-bit resolution		6.25		
		8-bit resolution		1.56		
ADC Conversion Time Accuracy		T _A = -40°C to +105°C			6	%
		T _A = +25°C			0.7	
INFRARED PROXIMITY RECEIVER CHARACTERISTICS						
Maximum Proximity Detection Sensitivity		850nm IR LED, 60μW/cm ²		1.5		μW/cm ² /LSB
Sunlight Rejection Offset		No reflector 0 to 100k lux		0		Counts
Sunlight Rejection Gain Error		With reflector 0 to 100k lux		0.1		Counts/klux