



AMKASYN
Servo Drives KE/KW.

Compact, powerful, modular.

AMK

BENEFITS

- Safety inside
- Motion Control
- Up to 50% less cabinet volume
- Energy saving
- Cold plate / heat recovery
- Control performance

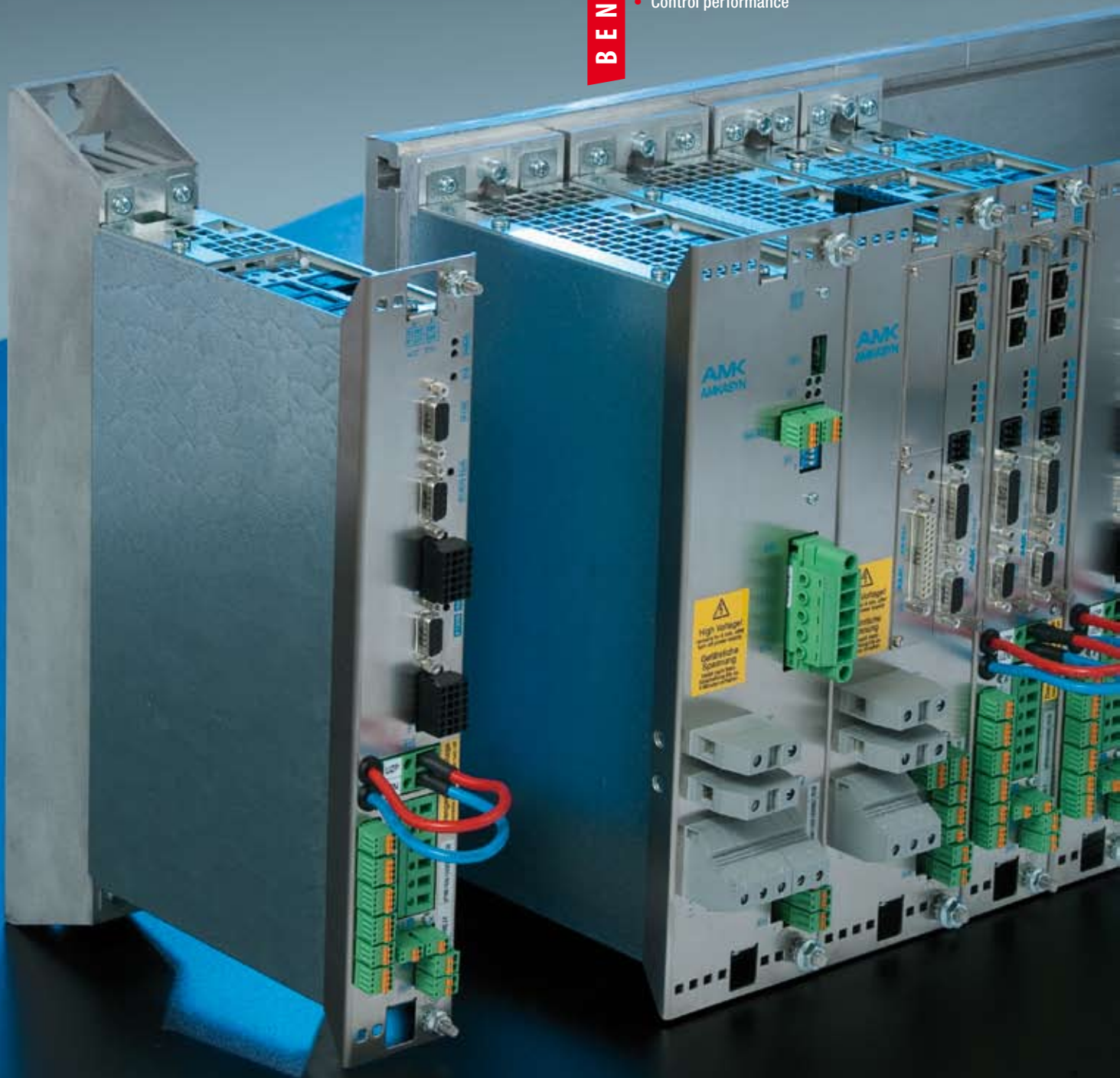



Take advantage of your space-saving potential! With the most compact servo drives.

The most compact way to show size.

Discover the added value of power density. With the intelligent servo drives KE/KW the available framesize is used effectively. The innovative cooling technology of AMK guarantees optimum heat dissipation and increases service life. The result: 50% of the volume can be saved. The flexible mounting of the modules allows ergonomic machine design.

The drive system for high-dynamic positioning duties.

The controller platform in the AMK drive system KE/KW with the newest processor design opens up new possibilities for higher performance. Realtime Ethernet (RTE) via EtherCAT or VARAN offers a powerful system communication for the automation of your machine. The utilization of only those modules that are actually required paves the way for optimum cost effectiveness. All types of synchronous or asynchronous servo, high-torque or linear motors with various encoder systems can be operated in a highly dynamic and precise manner.

Be on the safe side.

The drives offer a maximum safety standard. The safety function „STO“ is certificated in the safety category 4 under EN 954 as well as in the highest safety level PL e of the newest safety norm according to EN ISO 13849-1 and available in the inverters. Further safety functions can be realized through the use of the controller card KW-R07.

Sustainability through maximum energy efficiency.

The supply modules are line regenerative and therefore especially energy-efficient in order to save energy costs. The products of the range KES supply the energy obtained by the generator-based braking highly effective and sinusoidal back in your network. In addition, the regulated DC bus voltage provides higher speeds and power for your motors. The input currents are limited in their peaks and a power factor of nearly 1 will be realized. The system-related power loss can be used by the heat recovery of the cold plate technology for your processes.

System overview

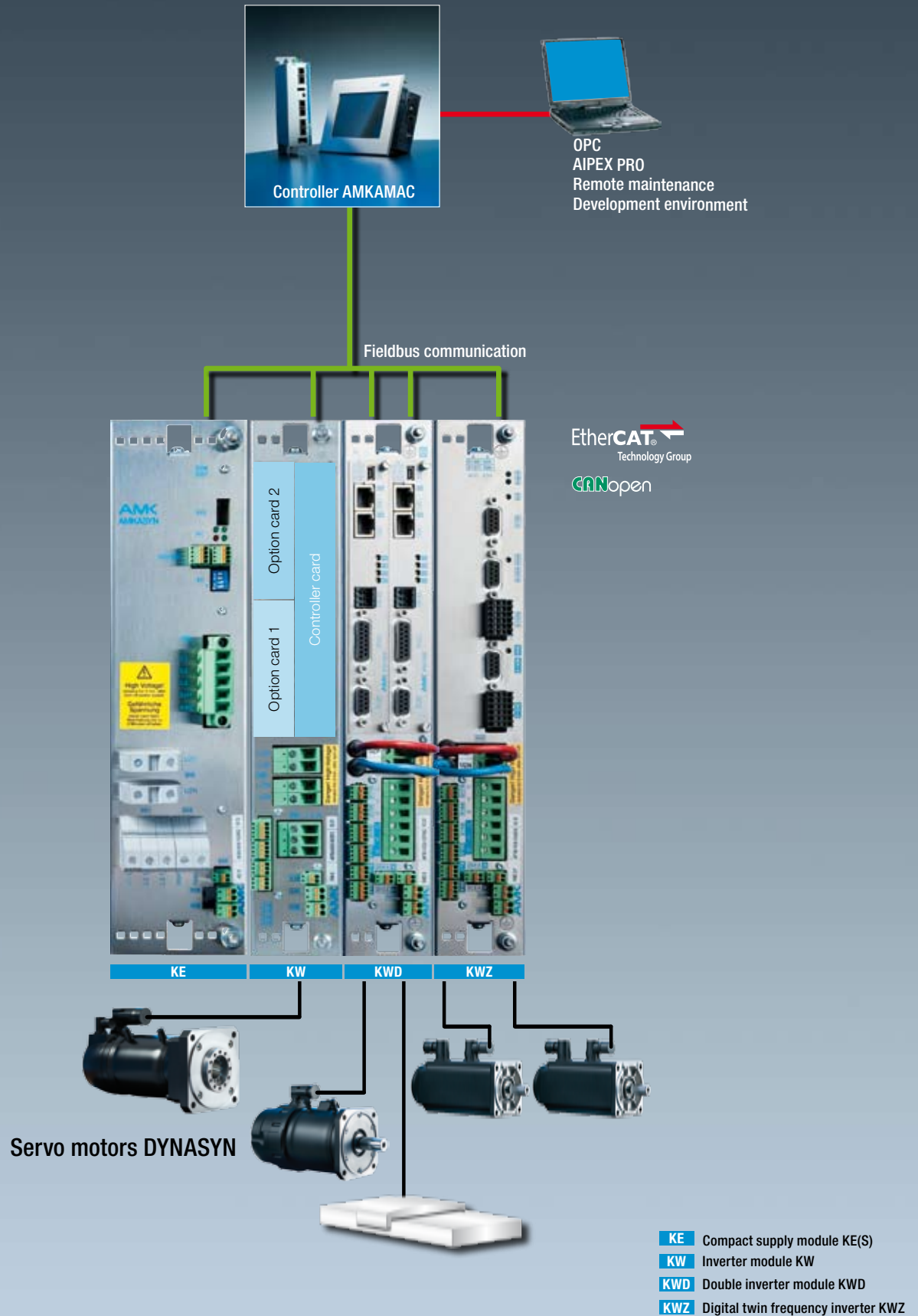

Compact supply module

Compact supply module, optional without line regeneration, with block commutated line regeneration or sinusoidal supply and line regeneration.

Compact inverter

Inverter for high-dynamic control of servo motors. Multifunctional network-capable as single or double inverter with plug-in controller cards and as two-axes inverter with built-in controller card.

Controller cards

The controller cards are placed in the plug-in slot of the compact inverter module.

Depending on the bus system and performance there are different types.

Option cards

For individual function extension, the inverter KW provides up to two plug-in slots for option cards.

Trendsetting cooling technology

AMK inverters are a market leader in compactness and power density for many years because of the efficient heat removal. The cold plate modules are easily mounted on a liquid- or air-cooled plate.

The liquid-cooled cold plate offers in particular at high power enormous advantages. The products can be mounted very easily without interrupting the cooling circuit. The heat dissipation through the liquid-cooled plate reduces the cooling requirements of the cabinet interior considerably.

For small power, the modules with integrated air-cooling offer a cost-effective solution.

Communication

Fieldbusses:

- EtherCAT
- CANopen
- SERCOS
- Profibus DP
- VARAN

Multifunctional I/O

- Digital inputs and outputs
- Analogue input
- Measurement input
- Impulse output

Standard functions

- Torque control
- Speed control
- Position control
- Positioning function
- Homing cycle in many variations
- Synchronous control
- Electronic line shafting
- Holding brake control
- Safety functions

Functional safety

Integrated safety function "STO" in category 4 according to EN 954-1 as well as in the highest safety level PL e of the newest safety norm according to EN ISO 13849-1. Further safety functions can be realized through the controller card KW-R07.

Design

Very compact dimensions. The system can be adapted due to space savings of up to 50% optimally to each machine ergonomic. Without the need for DC bus connection bars between the modules a flexible installation in the cabinet is possible.

Effective energy management

High efficiency rating and line regenerative braking reduce energy consumption and energy costs.

B E N E F I T S

- **Functional safety**
- **Reduction of the cabinet space of up to 50%**
- **Cost saving by possible integration of the cabinet as a part of the machine**
- **Cost-optimized solutions due to modular system structure**
- **Design of complex interconnected machines utilizing AMK's realtime synchronization**
- **Optimized cooling technology for every application**

ACC bus connection

AMK
AMKASYN

X236
X237

X23

H1

X22 X21

S1

X20

L1

L2

L3

EH1

EH2

High Voltage!
remains for 5 min. after
turn off power supply
**Gefährliche
Spannung**
bleibt nach Netz-
Ausschaltung bis zu
5 Minuten erhalten

JZP

X02

JZN

X01

X03

X25

L1.1

L2.1

L3.1

RBP

RBN

X09

X08

46257-1006-1542503 00.20

ME 20

– LED

– Digital in/output

– Fieldbus configuration

– Charging circuit 400...480VAC – 50/60Hz

– Main contactor control

– PTC thermistor for brake resistor

– 24 VDC supply,
looping 24VDC

DC bus voltage –

Line voltage 400...480VAC –
Connection braking resistor –

Compact supply module KE

Maximum power in minimum space.

The KE compact supply modules generate the DC bus voltage for the connected inverters and are available in the following versions:

KEN:

Not line regenerative supply module

KE:

Line regenerative supply module

KES:

Sinusoidal line regenerative supply module

The KES product range featuring sinusoidal supply and line regeneration generates a regulated DC bus voltage. The products stand out from various other systems due to their robust design. Higher drive speeds and performance can be achieved through the voltage boost in the DC link.

Features:

- Power ratings up to 120 kW
- Cooling in cold plate technology
- Line regenerative braking optional
- Protective functions
 - Overtemperature
 - Power failure
 - Input current
 - Short circuit protected
 - DC bus overcurrent
 - Main contactor control

B E N E F I T S

- High power density
- High efficiency
- Sustainability through line regeneration
- KES: Distortion of the main
- KES: Limits of harmonic currents according to EN 61000-3-12

Technical data

Type		KEN 5	KEN 10	KEN 120	KE 20	KE 40	KE 60	KE 120	KES 20	KES 60	KES 120	
Rated input voltage	VAC	3 x 400 ... 480 ± 10 %										
Mains frequency	Hz	47... 63										
Input current	A	13	15	180	30	60	90	180	30	90	180	
Rated output power	kW	5	10	120	20	40	60	120	20	60	120	
Maximum output power (for 60 s)	kW	10	20	200 ¹⁾	40	80	120	200	40 ²⁾	120 ²⁾	200 ²⁾	
Efficiency	%	ca.99							ca.98			
Power factor		0,55	> 0,9						0,98			
Cooling system		type cold plate										
Regeneration		No			Yes				Yes, sinusoidal			
External bleed resistor (Option) min.	Ω	22	22	2x8	20	8	8	8	20	8	8	
Protective function		Power failure, mains overcurrent, overtemperature module and bleed resistor										
Mains filter		integrated		external	integrated		external		external			
Weight	kg	3	3	16	4,2	8	8	16	4,2	8	16	
Module width	mm	55	55	255	85	170	170	255	85	170	255	
AMK part No.		E793	E816	E781	E717	E718	E719	E856	E944	E833	E834	

¹⁾ Motor, generator based max. 160 kW for 2,5 s ²⁾ for max. 10s



Option card 1 -

Option card 2 -

Output stage enable EF -

- Controller card

- DC Bus voltage and looping

- Motor connection

- PTC thermistor

- 24 VDC supply, looping

Compact servo drive module KW

Dynamic response and precision. With safety.

The digital compact servo drive modules KW control the motors in 4-quadrant mode precisely and with high dynamic response.

A multifunctional connection to a higher-level control unit via various field busses is possible.

Features:

- Power rating up to 100 kVA
- Cooling in cold plate technology
- Integrated safety function „STO“ in PL e according to EN ISO 13849-1 and category 4 according to EN954-1.
- Accommodates 1 controller card (KW-R03, KW-R03P, KW-R04, KW-R06 or KW-R07) and up to 2 option cards. Controller and option cards must be ordered separately.

B E N E F I T S

- Integrated safety function „STO“
- New dimensions in power density
- Effective heat removal and long service life due to cold plate technology
- High efficiency
- Compact machine design

Technical data

Type		KW 2	KW 3	KW 5	KW 8	KW 10	KW 20	KW 40	KW 60	KW 100
Input voltage	VDC	540 ... 650								
Switch-off barrier	VDC	850								
Input current	A	3,8	5,6	9,3	15	18,5	37	74	112	187
Rated output voltage	VAC	3 x 350 for sinusoidal currents								
Output frequency	Hz	0... 800 ¹⁾								
Rated output power	kVA	2	3	5	8	10	20	40	60	100
Maximum output power	kVA	4	6	10	16	20	40	80	120	200 ²⁾
Rated output current	A	3,3	5	8,2	13,2	16,5	33	66	99	165
Maximum output current (for 10s)	A	6,6	10	16,5	26,4	33	66	132	198	330 ³⁾
Efficiency	%	>98								
Cooling system		type cold plate								
Protective function		Motor overcurrent, short circuit, ground fault, overtemperature module and motor, I ² T monitoring								
Switching frequency	kHz	8 (4)								
Weight	kg	3	3	3	3	4,2	4,2	8	8	16
Module width	mm	55	55	55	55	85	85	170	170	255
AMK part No. without EF (without contr. card)		E764	-	E766	E814	-	-	-	-	-
AMK part No. incl. EF (without contr. card)		E765	E815	E767	E813	E768	E769	E770	E771	E855

¹⁾ 0...400 at 4 kHz PWM ²⁾ at 4 kHz PWM, 165 kVA at 8 kHz PWM ³⁾ at 4 kHz PWM, 247,5 A at 8 kHz PWM



Controller card 1 –

– Controller card 2

– DC Bus and looping

– Motor A

Output stage enable EF –

– Motor B

– PTC Thermistor motor A/B

– 24 VDC supply,
looping

Double servo drive module KWD

Two drives in one enclosure.

The compact servo drive module KWD contains two independent KW drives in one enclosure. This represents a low-cost and extremely compact solution for servo drives with low power ratings.

Features:

- Power rating up to 2 x 5 kVA
- Very compact dimensions
- Cooling in cold plate technology
- Integrated safety function „STO“ in PL e according EN ISO 13849-1 and category 4 according EN954-1.
- Accommodates 2 controller cards (KW-R03, KW-R03P, KW-R04, KW-R06 or KW-R07). Controller cards must be ordered separately.

B E N E F I T S

- Cost-effective and very compact solution for servo drives with small power
- Integrated safety function „STO“
- High efficiency
- More compact machine design

Technical data

Type		KWD 1	KWD 2	KWD 5
Input voltage	VDC	540... 650		
Switch-off barrier	VDC	850		
Input current	A	3,8	7,6	19
Rated output voltage	VAC	3 x 350 for sinusoidal currents		
Output frequency	Hz	0.....800 ¹⁾		
Rated output power	kVA	2 x 1	2 x 2	2 x 5
Maximum output power	kVA	2 x 2	2 x 4	2 x 10
Rated output current	A	2 x 1,65	2 x 3,3	2 x 8,3
Maximum output current (for 10s)	A	2 x 3,3	2 x 6,6	2 x 16,5
Efficiency	%	ca.98		
Cooling system		type cold plate		
Protective function		Motor overcurrent, short circuit, ground fault, overtemperature module and motor, I ² T monitoring		
Switching frequency	kHz	8 (4)		
Weight	kg	3		
Module width	mm	55		
AMK part No. without EF (without contr. card)		E762	E763	–
AMK part No. incl. EF (without contr. card)		E759	E760	E818

¹⁾ 0...400 at 4 kHz PWM



– LED Bus Status

– Operator panel connector RS 232

– Resolver

– 3 Digital inputs
 – 3 Digital outputs
 – 1 Analogue input

– Resolver

– 3 Digital inputs
 – 3 Digital outputs
 – 1 Analogue input

– DC Bus voltage and looping

– Motor A

– Motor B

– PTC thermistor motor

– 24 VDC supply
 looping 24VDC

Output stage enable EF –

Two-axes inverter module KWZ

Two inverters with integrated CPU card.

The two-axes inverter module contains two independent KW drives in one enclosure.

There is no additional controller card necessary because it is already integrated. This represents a low-cost and extremely compact solution for precise and dynamic control of synchronous, asynchronous and linear motors etc.

Combined with the compact supply modules, this are extremely low-cost multi-axes servo drive systems.

Features:

- 2 axes in one module in the power rating up to 2 x 5 kVA
- Servo operation of each axis with resolver
- Optional ACC bus (CANopen)-communication or EtherCAT
- Integrated safety function „STO“ in PL e according to EN ISO 13849-1 and category 4 according to EN954-1.
- Very compact dimensions.
- Cost savings in devices and wiring
- Cooling system in cold plate technology

B E N E F I T S

- No additional controller card necessary
- Cost-effective solution for drive systems, solutions and applications
- Integrated safety function „STO“
- High efficiency

Technical data

Type		KWZ 1	KWZ 2	KWZ 5	KWZ 1-EC	KWZ 2-EC	KWZ 5-EC
Input voltage	VDC	540...650					
Switch-off barrier	VDC	850					
Input current	A	3,8	7,6	19	3,8	7,6	19
Rated output voltage	VAC	3 x 350 for sinusoidal currents					
Output frequency	Hz	0...800					
Rated output power	kVA	2 x 1	2 x 2	2 x 5	2 x 1	2 x 2	2 x 5
Maximum output power	kVA	2 x 2	2 x 4	2 x 10	2 x 2	2 x 4	2 x 10
Rated output current	A	2 x 1,65	2 x 3,3	2 x 8,3	2 x 1,65	2 x 3,3	2 x 8,3
Maximum output current (for 10s.)	A	2 x 3,3	2 x 6,6	2 x 16,5	2 x 3,3	2 x 6,6	2 x 16,5
Efficiency	%	appr. 98					
Cooling system		type cold plate					
Protective function		Motor overcurrent, short circuit, ground fault, overtemperature module and motor, I ² T monitoring					
Switching frequency	kHz	8					
Fieldbus/communication		ACC bus (CANopen)			EtherCAT		
Weight	kg	3					
Module width	mm	55					
AMK part No. incl. EF		E841	E842	E843	E857	E858	E859

KE-F/KW-F with integrated air-cooling

The series KE-F/KW-F are equipped with an integrated air-cooling system.

The only difference between the module of this type and the modules in cold plate technology is the air-cooling element on the back of the module.

For appliances with low power, this series are a cost-effective solution.

The inverters of the F series have also the integrated safety function "STO" in PL e according to EN ISO 13849-1 as well as category 4 according to EN954-1.

KE-F with integrated air-cooling

Type		KEN 5-F	KEN 10-F	KE 20-F
Rated input voltage	VAC	3 x 400 ... 480 ± 10 %		
Mains frequency	Hz	47... 63		
Input current	A	13	15	30
Rated output power	kW	5	10	20
Maximum output power (for 60s) kW		10	20	40
Efficiency	%	appr. 99		
Power factor		0,55	> 0,9	
Cooling system		forced air-cooling		
Regeneration		No	No	Yes
External bleed resistor (option) min.	Ω	22	22	20
Protective function		Mains fail, mains overcurrent and overtemperature device and brake resistor		
Mains filter		integrated		
Weight	kg	3	3	4,2
Module width	mm	55	55	86
AMK part No.		E923	E924	E928



KW-F and KWD-F with integrated air-cooling

Type		KW 2-F	KW 4-F	KW 6-F	KW 9-F	KWD 1-F	KWD 2-F	KWD 4-F
Input voltage	VDC	540...650						
Switch-off barrier	VDC	850						
Input current	A	3,8	9,3	15	18,5	3,8	7,6	19
Rated output voltage	VAC	3 x 350 for sinusoidal currents						
Output frequency	Hz	0...800 ¹⁾						
Rated output power	kVA	2	4	6	9	2 x 1	2 x 2	2 x 4
Maximum output power	kVA	4	8	12	18	2 x 2	2 x 4	2 x 8
Rated output current	A	3,3	6,6	9,9	14,9	2 x 1,65	2 x 3,3	2 x 6,6
Maximum output current (for 10s)	A	6,6	13,2	19,8	29,7	2 x 3,3	2 x 6,6	2 x 13,2
Efficiency	%	appr. 98						
Cooling system		forced air-cooling						
Protective function		Motor overcurrent, short circuit, ground fault, overtemperature device and motor, I ² T monitoring						
Switching frequency	kHz	8 (4)						
Weight	kg	3			4,2	3		
Module width	mm	55			86	55		
AMK part No. incl. EF (without CPU card)		E910	E942	E943	E925	E914	E915	E916

¹⁾ 0...400 at 4 kHz PWM

KWZ-F with integrated air-cooling

Type		KWZ 1-F	KWZ 2-F	KWZ 4-F	KWZ 1-ECF	KWZ 2-ECF	KWZ 4-ECF	
Input voltage	VDC	540...650						
Switch-off barrier	VDC	850						
Input current	A	3,8	7,6	19	3,8	7,6	19	
Rated output voltage	VAC	3 x 350 for sinusoidal currents						
Output frequency	Hz	0...800						
Rated output power	kVA	2 x 1	2 x 2	2 x 4	2 x 1	2 x 2	2 x 4	
Maximum output power	kVA	2 x 2	2 x 4	2 x 8	2 x 2	2 x 4	2 x 8	
Rated output current	A	2 x 1,65	2 x 3,3	2 x 6,6	2 x 1,65	2 x 3,3	2 x 6,6	
Maximum output current (for 10s)	A	2 x 3,3	2 x 6,6	2 x 13,2	2 x 3,3	2 x 6,6	2 x 13,2	
Efficiency	%	appr. 98						
Cooling system		forced air-cooling						
Protective function		Motor overcurrent, short circuit, ground fault, overtemperature device and motor, I ² T monitoring						
Switching frequency	kHz	8						
Fieldbus/communication		ACC Bus (CANopen)				EtherCAT		
Weight	kg	3						
Module width	mm	55						
AMK part No. incl. EF		E935	E936	E937	E938	E939	E940	

Controller cards

Functionality made to measure

Realtime Ethernet

KW-R06

With the controller card KW-R06, AMK has created a new platform for outstanding controller performance in the AMK drive system: With EtherCAT/VARAN as realtime Ethernet interface, a fast system bus is available which is predestined for high dynamic positioning tasks. So more than 100 drives with setpoints can be used synchronously. Integrated filters avoid disturbances by noise or cyclic influence. If no absolute encoders are used, the commutation can be effected by software using a micro movement. Furthermore, the controller card has an option slot with which the system can be expanded through digital I/O's.

Functional safety

KW-R07

The KW-R07 is similar to the KW-R06. Additionally safe drive solutions up to PL e according to EN ISO 13849-1 can be realized. The control of the safety functions is carried out by safe I/O's or via FSoE by a safety PLC.

Safe stop functions

- STO - Safe Torque Off
- SOS - Safe Operating Stop
- SS1 - Safe Stop 1
- SS2 - Safe Stop 2

Safe movement functions

- SLS - Safely Limited Speed
- SDI - Safe Direction
- SSR - Safe Speed Range

ACC Bus

KW-R03, KW-R03P, KW-R04

The KW-R03 is a controller card with full functionality. For connection to a control and to additional participants, the CANopen (ACC bus) interface is available. Up to 32 drives with setpoints can be used synchronously. The controller card offers two option slots for expanded functionality.

The KW-R03P adds PLC functionality.

The KW-R04 is similar to the KW-R03 without the encoder connection X131.

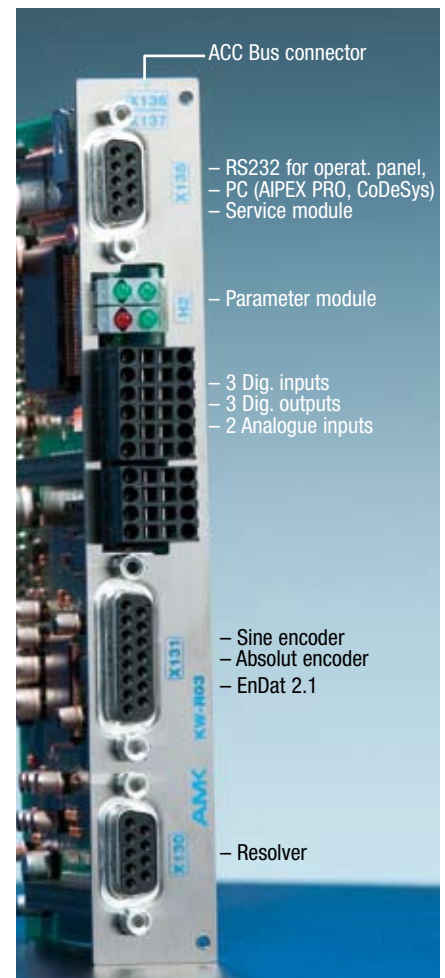
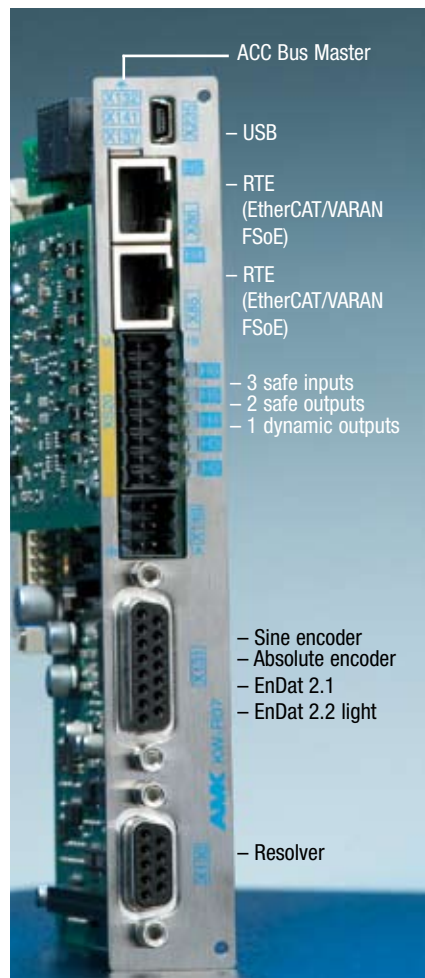
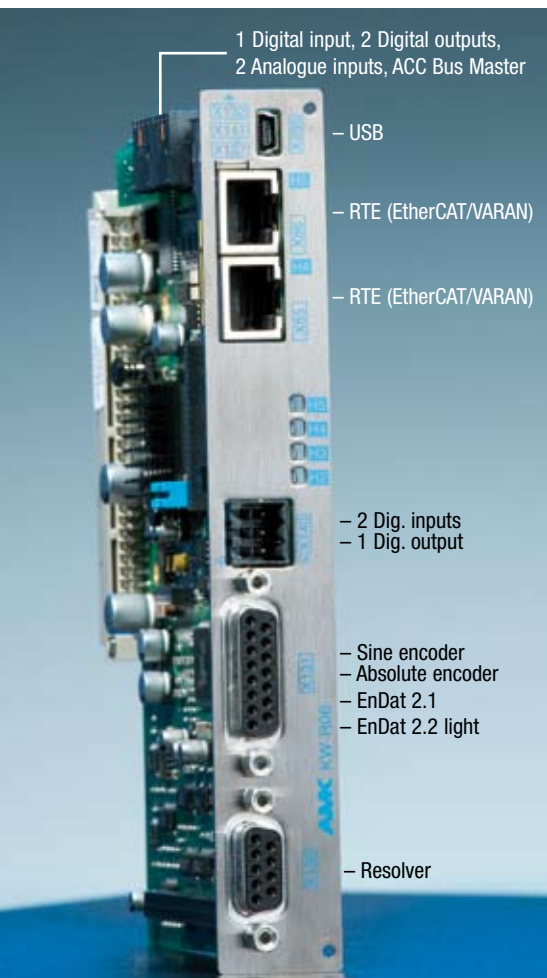

Description

The controller cards are inserted into the card plug-in slot of the compact servo drive module KW. The entire control of the drives including all monitoring and communication is realized via the digital signal processor on the card.

The controller cards KW-R03 and KW-R03P offer 2 additional card connectors, the controller card KW-R06 offers one additional card connector for option cards. The option cards are connected using a bus connector in the appropriate position on the controller card.

Functions

- Control motor brake
- Electronic gear
- Probe function
(actual position encoder/square wave pulse)
- Number of probe inputs according SERCOS
- Homing cycle
- Spindle positioning
- Change of operating mode
- Transfer of the parameter set
- Digital/analogue speed control
- Absolute/relative positioning

Overview controller cards

Functions	KW-R06	KW-R07	KW-R03	KW-R03P	KW-R04	KWZ
Drive control						
Minimum fieldbus cycle time	250 µs	250 µs	500 µs	500 µs	500 µs	1000 µs
PLC functionality	–	–	KW-PLC2, option	Integrated	–	–
Encoder processing						
Resolver connection	✓	✓	✓	✓	✓	✓
Sine encoder	✓	✓	✓	✓	–	–
EnDat 2.1	✓	✓	✓	✓	–	–
Hiperface	✓	✓	✓	✓	–	–
EnDat 2.2 light	✓	✓	–	–	–	–
Hall generator (over resolver input)	✓	✓	✓	✓	–	–
Square wave signal interface (input/transfer)	✓	✓	✓	✓	✓	–
2. encoder connection, e.g. charge encoder	✓	✓	✓	✓	✓	–
U/F running without encoder	✓	✓	✓	✓	✓	✓
I/O interfaces						
Analogue input ±10V (release)	2 (12 Bit)	2 (12 Bit)	2 (12 Bit)	2 (12 Bit)	2 (12 Bit)	1 (12 Bit)
Local digital inputs	3	3	3	3	3	3
Local digital outputs	3	3	3	3	3	3
Square wave impulse output (SIWL), f _{max}	500kHz	500kHz	500kHz	500kHz	500kHz	–
Fieldbus interfaces						
Realtime bus ACC	Master	Master	✓	✓	✓	✓
EtherCAT (SoE)	Slave	Slave	Option	Option	–	✓
Service						
Service Port	USB 1.1	USB 1.1	RS232	RS232	RS232	RS232
AIPEXPRO connection	USB/EtherCAT	USB/EtherCAT	RS232/ACC	RS232/ACC	RS232/ACC	RS232/ACC
Functional safety	–	✓	–	–	–	–

Option cards

Individual function enhancement.

A range of option cards are for individual function enhancement, which can be inserted into the inverter's controller card.

Functions:

- Fieldbusses
- PLC for Motion Control and machine control
- Encoder interfaces
- I/O extension



Controller component			
KW-R03	●	●	●
KW-R03P	●	●	●
KW-R04	-	-	-
KW-R06	●	-	-

I/O Extension KW-EA2

This option card paves the way for a low-cost enhancement of the KE/KW system with digital inputs and outputs, which can also be used to control motion profiles.

Features:

- 12 digital 24V inputs in compliance with VDI 2880
- 8 optically isolated 24V outputs each rated at 100mA
- Short-circuit monitoring of the outputs
- Bit information within the drives configurable for outputs
- Triggering of various drive functions configurable through inputs
- With "Configurable Control PLC", the I/O can be used as PLC inputs and outputs.

Encoder interface KW-EN1

This option card enables connection of a second sinusoidal encoder measuring system. This means that both a high-resolution, linear scale for position feedback and a sinusoidal encoder system for speed control and commutation can be connected to one KW.

Features:

- Absolute encoder with actual position encoder in the form of Endat[®]2.1
- Ext. 24 V incoming encoder supply
- Probe input through 1 digital input 24V

Encoder interface KW-SSI

The option card KW-SSI provides the actual position value through a SSI interface for a higher-level controller.

Features:

- Actual position value is cyclically updated depending on the SERCOS cycle time
- Minimal updating rate = 500µs
- Actual position value can be sampled by higher-level controller in a cycle of >=1ms
- KW-SSI works as cycle slave
- Independent of plug-in slot
- Automatic recognition





•	•	•	•
•	•	•	•
-	-	-	-
-	-	-	-

Fieldbus KW-EC1

The option card KW-EC1 facilitates communication between a higher-level controller (EtherCAT master) and the KW module (EtherCAT slave) using the SoE (servo drive over EtherCAT) profile.

Features:

- EtherCAT protocol with servo drive profil (SoE)
- Synchronous data and parameters according to SERCOS (IDs)
- Min. cycle times (500 µs)
- Optional setting of addresses via rotary coding switches

Fieldbus KW-SC1

The interface card KW-SC1 transforms the drive into a SERCOS interface® slave. This slave is based on the SERCOS interface® slave Version V 1.02. in compliance with DIN EN/IEC 61491.

Features:

- SERCOS class C
- Communication cycle time minimal 0.5 ms
- Transfer rate up to 16Mbit/s
- Broadcast Message to all drives available

Fieldbus KW-PB1

The interface card KW-PB1 PROFIBUS-DP allows communication between a PROFIBUS Master and the drive via **AMK fieldbus protocol AFP** for drive commanding.

Features:

- Connection of the inverter to a PROFIBUS-DP MASTER in compliance with DIN 19245, part 3
- Maximum 32 slaves per line (can be enhanced to max. 122 slaves with repeater)
- Baud rate 12 Mbit/s
- Address assignment via rotary encoding switch
- Max. 48 input and 48 output bytes
- AFP driver component for Siemens S7 SPS available

PLC for machine control KW-PLC2

PLC according IEC 61131-3. For all complex machine control functions including visualization as well as the execution of axis-specific tasks. In addition, the option card offers a hardware synchronous CANopen interface.

Features:

- CANopen in accordance with DS301 version 4.01.
- Additionally CAN BUS MASTER or SLAVE
- Hardware synchronized signal scanning, jitter < 1µs
- Comprehensive AMK Motion Control
- 2 fast probe inputs with a resolution of up to 200 ns
- RS422 MODBUS interface for data exchange between PLC and an external operator panel/visual display unit
- 584 kByte program memory
- 128 kByte data memory
- 32 kByte RETAIN memory

AIPEXPRO

Engineering Tool



PLC programming

Technology functions

Machine setup

Visualization

Diagnostic

Motion control

Remote maintenance

Engineering and application with **AIPEXPRO**

AIPEXPRO integrates all engineering tools needed during the life cycle of a machine, such as programming, parameterization, commissioning, optimization and diagnostics. This saves you time-consuming efforts to coordinate, for example, between your PLC program containing drive parameters and the configuration of user data exchange via the field bus. AIPEXPRO does this work for you automatically and frees you from all tasks not directly tied to your application.

Configuration

With the configuration, the components of the drive system can be assembled from a data base (motor, converter, controller component, option cards, controls, I/O components).

- Automatic fieldbus configuration
- Parameterization
- Commissioning

Programming

AIPEXPRO integrates the worldwide approved programming platform CoDeSys. All programming languages according to IEC 61131-3 are supported and can even be combined within one project. For programming (in favored language) preprogrammed function blocks in countless libraries are available.

In the development environment, the visualization and the basic library are contained as a foundation for the automation solution. In the basic library, extensive basic modules as e.g. mathematic functions and logic modules (timer, counter) are included.

Visualization

The machine visualization can be compiled with the graphic function of the integrated visualization editor, also by pre-assembled visualization modules. The User will be able to access the web visualization in the AMK drives worldwide.

Libraries

This tool allows use of extensive preprogrammed motion control and technology functions.

Motion control libraries

The basic functions of your machine control are contained in these modules, such as electronic cam control and cam function.

Technology function

You can further simplify your engineering by using the technology functions, for instance form, fill, seal and print mark control, winder and cross cutter functions.

Remote maintenance and diagnostic

You have access to the machine control and the drives from any location.

With the update tool in AIPEXPRO you can quickly and easily update the firmware.

B E N E F I T S



- All programming languages according to IEC 61131-3
- Economical generation of your machine software
- Reduction of the time-to-market of your machine
- Realize innovative machine concepts per drag & drop
- Comprehensive preprogrammed AMK technology functions
- Integrated web visualization accessible worldwide

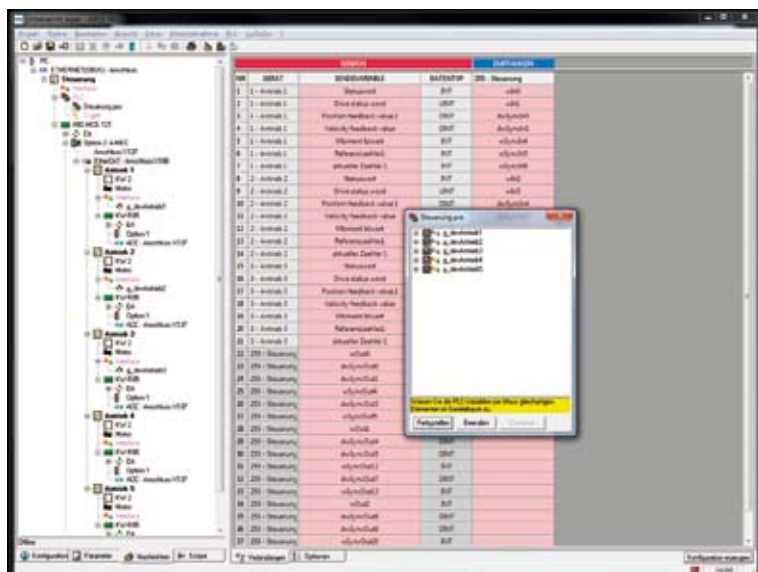

Automatic fieldbus configuration.

The revolutionary coupling of component configuration and programming environment has made fieldbus configuration very easy. AIPEXPRO recognizes all data that has to be transferred and automatically generates the configuration of the fieldbus. Data are prepared, depending on their use in the PLC program, either synchronously or asynchronously. Fully automatically and reliably.

The programmer is thus freed from tedious work and can fully concentrate on the important aspects of the machine control.

Drive data as well as I/O data are configured fully automatically.

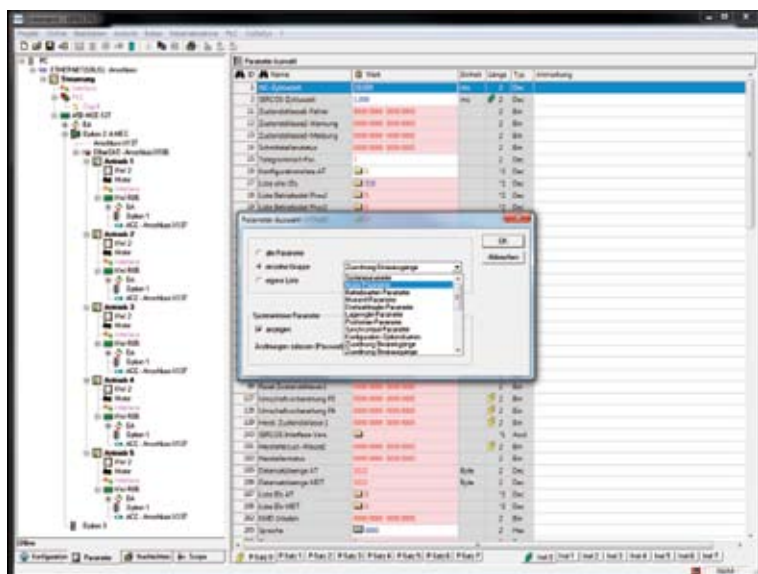

Simple parameterization of the drives.

The drive system consists of the servo inverters and motors which together have to optimally fulfill the tasks. Wizards aid in the parameterization for standard configurations of the drive. Using the parameter explorer you have access to all parameters in the system. Adjustments and optimizations can also be made during operation. The temporary changes are directly adopted.

AIPEXPRO has access to all devices on the fieldbus network. From one central location all parameters and configuration data can be read as well as written. Troubleshooting is made easier by the central access with AIPEXPRO. As soon as a message is generated, you receive it in plain text with additional information displayed.

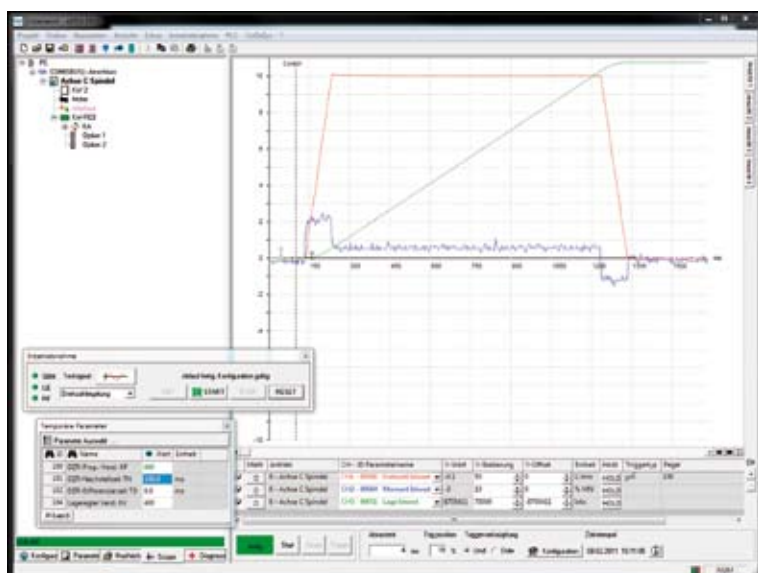

Start-up.

- Internal setpoint generator with sine-wave, triangle, trap-zoid and step generators for torque, speed and position setpoints
- Temporary parameter access for the online tuning of all control parameters
- Integrated oscilloscope
 - Measurement of all internal data such as position values, speed values, currents, torques, digital I/O voltages etc.
 - Up to 8 variables can be recorded per device
 - Diverse trigger (flank, event, level)
 - Cursor measuring function (time, absolute value, difference)
 - Hold function for measured data
 - 4 different views possible for each device
 - Saving and exporting of measured values

Device type

Designation	Product information	AMK part No.
KE Power supply module without regeneration		
KEN 5	5 kW	E793
KEN 10	10 kW	E816
KEN 120	120 kW	E781
KE Power supply module with regeneration		
KE 20	20 kW	E717
KE 40	40 kW	E718
KE 60	60 kW	E719
KE 120	120 kW	E856
KES Power supply module with regeneration sinusoidal		
KES 20	20 kW	E944
KES 60	60 kW	E833
KES 120	120 kW	E834
KE Power supply module without regeneration with forced air-cooling		
KEN 5-F	5 kW	E923
KEN 10-F	10 kW	E924
KE Power supply module with regeneration with forced air-cooling		
KE 20-F	20 kW	E928
KW Inverter module without controller card		
KW 2-0N	2 kVA, without power output stage enable	E764
KW 2	2 kVA, with power output stage enable	E765
KW 3	3 kVA, with power output stage enable	E815
KW 5-0N	5 kVA, without power output stage enable	E766
KW 5	5 kVA, with power output stage enable	E767
KW 8-0N	8 kVA, without power output stage enable	E814
KW 8	8 kVA, with power output stage enable	E813
KW 10	10 kVA, with power output stage enable	E768
KW 20	20 kVA, with power output stage enable	E769
KW 40	40 kVA, with power output stage enable	E770
KW 60	60 kVA, with power output stage enable	E771
KW 100	100 kVA, with power output stage enable	E855
KW Inverter module without controller card with forced air-cooling		
KW 2-F	2 kVA, with power output stage enable	E910
KW 4-F	4 kVA, with power output stage enable	E942
KW 6-F	6 kVA, with power output stage enable	E943
KW 9-F	9 kVA, with power output stage enable	E925
KWD Double inverter without controller card		
KWD 1-0N	2 x 1 kVA, without power output stage enable	E762
KWD 1	2 x 1 kVA, with power output stage enable	E759
KWD 2-0N	2 x 2 kVA, without power output stage enable	E763
KWD 2	2 x 2 kVA, with power output stage enable	E760
KWD 5	2 x 5 kVA, with power output stage enable	E818
KWD Double inverter without controller card with forced air-cooling		
KWD 1-F	2 x 1 kVA, with power output stage enable	E914
KWD 2-F	2 x 2 kVA, with power output stage enable	E915
KWD 4-F	2 x 4 kVA, with power output stage enable	E916
KWZ Double inverter with ACC, with power output stage enable and controller card integrated		
KWZ 1	2 x 1 kVA	E841
KWZ 2	2 x 2 kVA	E842
KWZ 5	2 x 5 kVA	E843
KWZ Double inverter with ACC, with power output stage enable and controller card integrated with forced air-cooling		
KWZ 1-F	2 x 1 kVA	E935
KWZ 2-F	2 x 2 kVA	E936
KWZ 4-F	2 x 4 kVA	E937
KWZ Double inverter with EtherCAT, with power output stage enable and controller card integrated		
KWZ 1-EC	2 x 1 kVA	E857
KWZ 2-EC	2 x 2 kVA	E858
KWZ 5-EC	2 x 5 kVA	E859

Designation	Product information	AMK part No.
KWZ Double inverter with EtherCAT, with power output stage enable and controller card integrated, with forced air-cooling		
KWZ 1-ECF	2 x 1 kVA	E938
KWZ 2-ECF	2 x 2 kVA	E939
KWZ 4-ECF	2 x 4 kVA	E940
KW Controller card		
KW-R03	With ACC bus	0688
KW-R03P	ACC bus with PLC	0689
KW-R04	ACC bus, only resolver	0690
KW-R06	Realtime EtherCAT/VARAN	0835
KW-R07	EtherCAT/VARAN with functional safety	0807
KW Optional modules for KW-R03/KW-R04 and KW-R03P		
KW-EN1	EnDat Interface	0751
KW-EC1	EtherCat Interface	0804
KW-PB1	Profibus DP Interface	0667
KW-SC1	SERCOS Interface	0669
KW-EA2	I/O card, 12I/8O	0664
KW-PLC2	Programmable control 128 kB	0750
KW-SSI	Encoder interface for SSI Encoder	0803

Accessories

Designation	Product information	AMK part No.
KE/KW Cold plate with cooling connection on the side for cold plate devices		
KW-CP340	L=340 mm	0704
KW-CP510	L=510 mm	0706
KW-CP680	L=680 mm	0708
KW-CP680-V	L=680 mm, stainless steel tube	0782
KE/KW Cold plate with cooling connection on the rear side for cold plate devices		
KW-CP340R	L=340 mm	0705
KW-CP420R	L=420 mm	0710
KW-CP510R	L=510 mm	0707
KW-CP680R	L=680 mm	0709
KW-CP680R-V	L=680 mm, stainless steel tube	0783
KW-CP1035R	L=1035 mm	0734
KE/KW Cold plate with fan for cold plate devices		
KW-LK110	110 x 418 x 46 (cooling plate)	0745
KW-LK250	250 x 465 x 84 (cooling plate)	0743
KW-LK400	400 x 465 x 84 (cooling plate)	0744
KW-LK500	500 x 465 x 84 (cooling plate)	0802
Mounting hardware		
20 terminal blocks and discs	For mounting of cold plate devices on AMK cooling plate	49994
Braking resistors		
AR 45	All supplies	0536
AR 80-20-0	KE 20	29433
AR 140	KEN 5, KEN 10	0746
AR 1000-50-F	All supplies	E586
AR 4000-8-F	KE 40, KE 60	E585
AR 4000-8-0	KE 40, KE 60	E584
AR 4000-20-F	KE 20	E593
AR 4000-20-0	KE 20	E591
AR 4000-40-F	KE 10	E601
Operator panel		
KU-BF1	For KW with KW-R03, KW-R03P, KW-R04	E628
Mains contactor		
	For KE 20, KES 20, coil 24 V	200593
	For KE 40, coil 24 V	29297
	For KE 60, KES 60, coil 24 V	29298
	For KE 120, KES 120, coil 24 V	200446
		29300

Accessories

Designation	Product information	AMK part No.
Mains filter		
AF 90	KE 60, 3 x 480 VAC, 90 A	0820
AF 180	KE 120, KEN 120, 3 x 480 V, 180 A	0821
AF 90-S	KES 60, 3 x 480 V, 90 A	0825
AF 180-S	KES 120, 3 x 480 V, 180 A	0812
AMKASYN Mains choke		
ALN 17	For KEN 10	0742
ALN 36/1000	For KE 20, 36 A	0727
ALN 63	For KE 40, 63 A	0728
ALN 85	For KE 60, 85 A	0729
ALN 180	For KE 120, KEN 120	0739
ALN 15-SI	For KES 20, 15 A/Pulse charge	0829
ALN 45-SI	For KES 60, 45 A/Pulse charge	0789
ALN 60-SI	For KES 120, 60 A/Pulse charge	0790
ALN 90-S	For KES 60, 90 A/Continuous operation	0770
ALN 180-S	For KES 120, 180 A/Continuous operation	0771
AMKASYN Upstream mains choke		
ALNV 15-SI	For KES 20, 15/60 A	0841
ALNV 90-S	For KES 60, 90/180 A	0826
ALNV 180-S	For KES 120, 180/300 A	0827
DC bus cable blue/red		
KW-UZ55	L=180mm,10mm ²	46621
KW-UZ85	L=45mm, 10mm ²	46620
KE-UZ170	L=117mm, 10mm ²	46376
KW-UZ170	L=114mm, 25mm ²	46622
KW-UZ255	L=380mm, 50mm ²	46908
KE-UZ255	L=350mm, 25mm ²	46975
ACC bus cable		
KW-ACC140	L=140 mm	29237
KW-ACC210	L=210 mm	29231
KW-ACC300	L=300 mm	200053
KW-ACC1000	L=1000 mm	29523
KW-ACC1800	L=1800 mm	29543
KW-ACC5000	L=5000 mm	200507
KW-ACC10000	L=10000 mm	29545
KW-ACCT	Terminating plug	29240
EC bus cable		
Cable RJ45 0,2 m	L=200 mm	202665
Cable RJ45 0,3 m	L=300 mm	202666
Cable RJ45 0,4 m	L=400 mm	202667
Cable RJ45 1,0 m	L=1000 mm	202668
Cable RJ45 2,0 m	L=2000 mm	202669
Cable RJ45 5,0 m	L=5000 mm	202670
Cable RJ45 10,0 m	L=10000 mm	202671
Accessories		
AP-CI3	Adapter ACC on Wago	0777
AP-CI4	Adapter ACC for gen. CAN connection	0778
AP-CI6	Adapter ACC for gen. CAN connection	0780
AIPEX PRO	Engineering tool	0814
AIPEX Lite	Engineering tool on demand	

Dimensions cold plate types

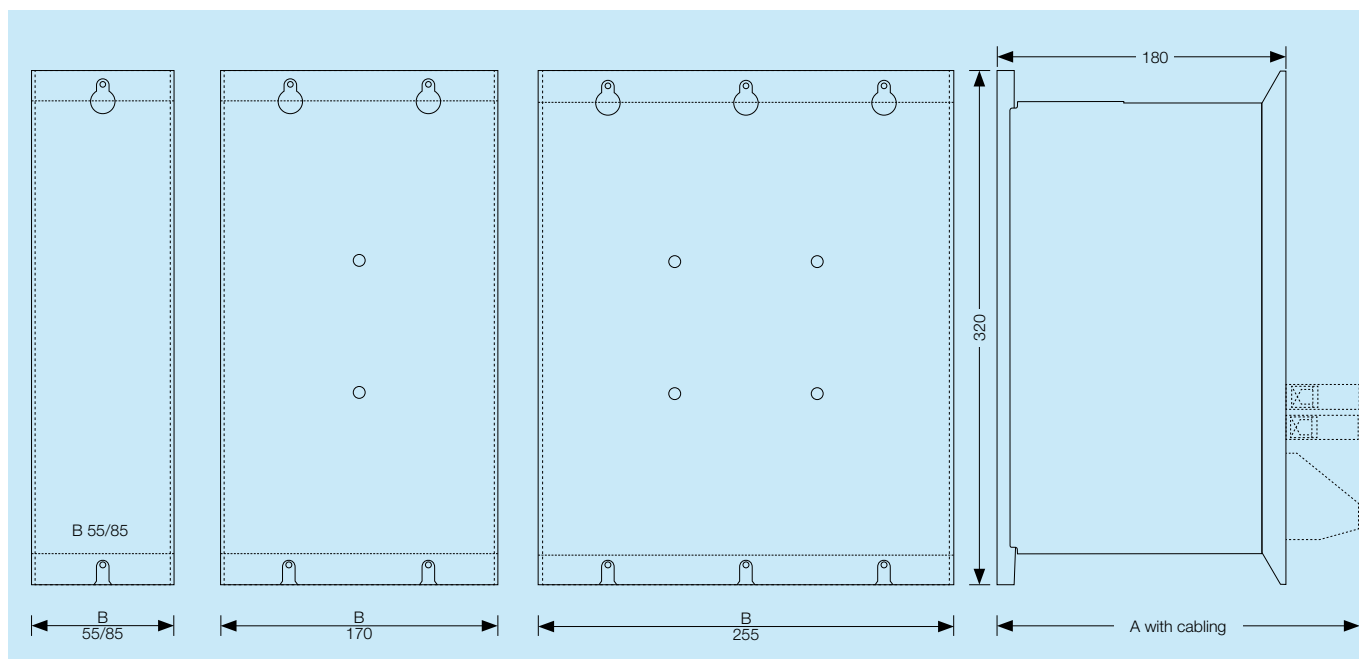

Modules	B (Module width in mm)	A (Module depth in mm with cabling)
KEN 5 / KEN 10 / KW 2 / KW 3 / KW 5 / KW 8 / KWD 1 / KWD 2 / KWD 5 / KWZ 1(EC) / KWZ 2(EC) / KWZ 5(EC)	55	230
KE 20 / KES 20 / KW 10 / KW 20	85	230
KEN 60 / KE40 / KE60 / KES 60 / KW 40 / KW 60	170	240
KE 120 / KEN 120 / KES 120 / KW 100	255	270

Dimensions devices with integrated air-cooling

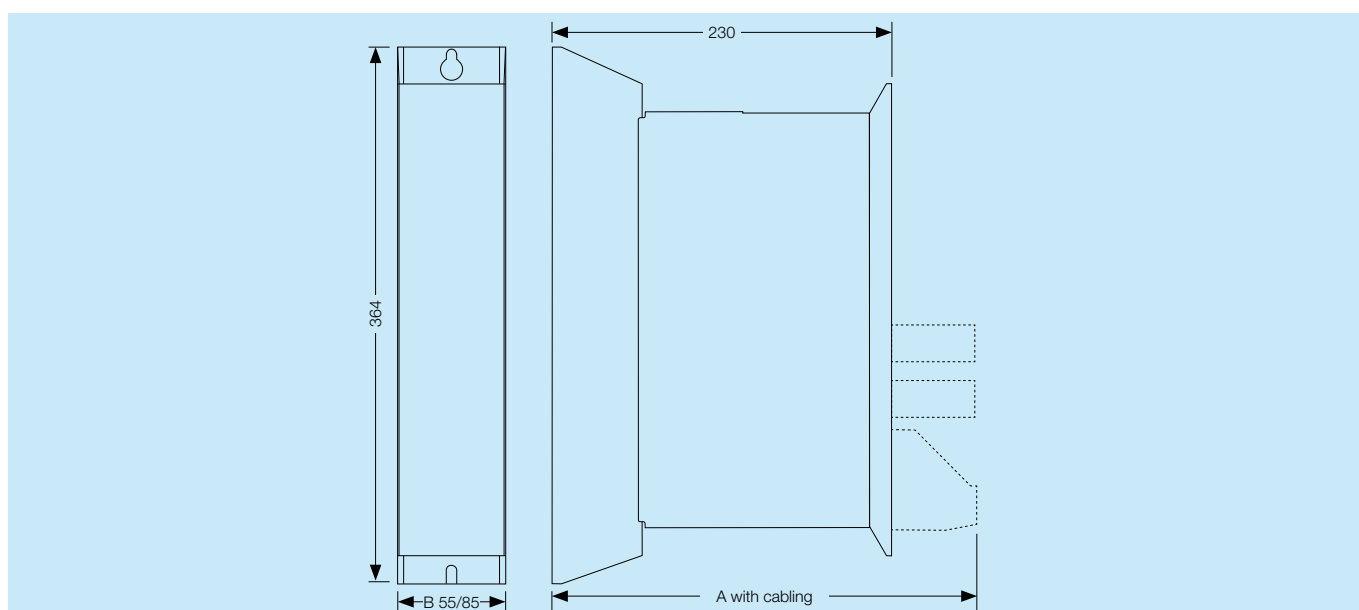

Modules	B (Module width in mm)	A (Module depth in mm with cabling)
KEN5-F / KEN10-F / KW2-F / KW4-F / KW6-F / KWD1-F / KWD2-F / KWD4-F / KWZ1- (EC) F / KWZ2-(EC) F, KWZ4-(EC) F	55	261
KE 20-F / KW9-F	86	261

Business solutions.

Economical, modular and high-performance.

Innovative drive and control solutions from AMK offer exactly the right product for many machines and systems:

- Printing
- Paper processing
- Machine tool manufacture
- Textiles
- Plastics
- Packaging
- Food industry

Our application engineers have a wide range of theoretical and practical knowledge and are happy to create a customized solution for every branch of industry.



Printing.

High level of precision and dynamics. 1,000 axes, 18 meters per second.



Paper unwinder.

In-process change at full production speed.



Paper processing.

At speeds of 10 m/s printing marks in the size of 2x2 mm are recognized with an accuracy of +/- 30 µm.

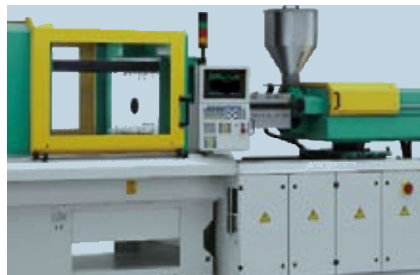

Plastics.

Cycle times of 1.6 seconds. Highest demands on precision and repeatability.



Food industry.

Flexible use of labelling machines for a wide-range of bottle formats.



Packaging.

Form, fill and seal machines, envelope and blister packaging, foil wrapping machines or palletizers.

B E N E F I T S

- Complete drive and control system from one source
- Extensive industry expertise for innovative machine concepts
- AMK technology library with motion control function modules also for your application

Service, training and consulting.

Our expertise specially for you!

Service

AMK is committed to offering an extensive range of services. When help is needed, our specialists from "Technical Support" provide valuable assistance in the planning, design, installation, commissioning and programming phases.

Consulting

We provide individual and project-related consulting services to support you in the operation of your particular drives and controllers. You receive precisely the information you need based on your specific requirements.

Training

Our extensive training programme provides theoretical and practical know-how and offers various training options either at our training center or at your company.

The programme extends from basic training to expert workshops. If required, we can also provide individual, project-orientated training.

General technical data

Directives and standards

- Low voltage directive 73/23/EWG and 93/68/EWG
- EN 50178 "Electronic equipment for use in power installations"
- EN 61800-2 "Adjustable speed electrical power drive systems, General requirements"
- EN 61800-3 "Adjustable speed electrical power drive system, EMC product standard"
- UL 508C "Power Conversion Equipment".
- CSA C22.2 "Industrial Control Equipment"

Machine standards:

- Machine Directive 89/392/EWG
- EMV Directive 89/336/EWG
- EN 60204 "Electrical equipment of machines"

Input Power:

3 x 400 V...480 V \pm 10%, 47... 63 Hz
General operating requirements in compliance with EN 61800-2 chap. 4.1.1 and EN 60204-1 chap. 4.3

- Symmetrical three-phase input voltage, max. permitted voltage asymmetry 3% TN and TT network, grounded neutral
- Suitable for IT networks

Reference potential:

PE, circuit GND of low voltage circuit is connected internally with the frame ground.

Power supply unit for supply voltage

24 VDC \pm 15%, ripple max. 5% with integrated starting current limitation.

Limit values for radio interference voltage in compliance with EN 61800-3: (2000) in accordance with Section 6.3.2 Tab. 11 and Tab.12 (external filter required from KE 60 upwards).

Ambient conditions

Protection type in compliance with EN 60529:

IP 20, contamination level 2

Storage/transport temperature:

-25°C to +75°C

Ambient temperature:

+5°C to +40°C

Cold plate temperature (liquid cooling):

Max. 40°C

Relative humidity:

5% to 85%, without condensation

Setup height:

Up to 1000 m above sea level. In the case of altitudes over 1,000 m up to max. 2,000 m the ratings must be reduced by 1% per 100 m.

Shock resistance:

15 g for 11 ms in compliance with EN 60068-2-27

Vibration stress:

1 g at 10...150 Hz in compliance with EN 60068-2-6



Control your Motion.



■ **AMKAMAC**
Controllers

■ **AMKASYN**
Servo inverters

■ **DYNASYN**
Servo motors

■ **AMKASMART**
Inverter-integrated
motors

■ **SPINDASYN**
Hollow-shaft motors

■ **TORGSystem®**
Drive motors

■ **AMKAVERT**
Frequency inverters

AMK

AMK Arnold Müller GmbH & Co. KG
Drives and Controls

Postfach 1355
D-73221 Kirchheim/Teck

Gaußstraße 37-39
D-73230 Kirchheim/Teck

Phone: +49(0)70 21/50 05-0
Fax: +49(0)70 21/50 05-199

info@amk-antriebe.de
www.amk-antriebe.de