

**Pressure Transmitter with Display,  
Rangeable Wet/Wet Differential**

**Product Details**

The Omega differential PX3005-DIFF is a compact, rangeable, pressure transmitter ideal for monitoring pressures in process automation, hydraulic systems, compressors, pumps, and in tank level applications where consistent, reliable pressure measurement is essential. The PX3005-DIFF utilizes a unique encapsulation construction of a MEMs piezoresistive pressure sensor coupled to an advanced microprocessing to provide superior accuracy and performance.

The unique construction enables high line pressure operations and superior protection from pressure overloads. The rugged 316 stainless-steel enclosure is IP67 rated making it suitable for wash down environments. A 5-digit backlit LCD allows for a full precision representation of process variable. Available in ranges from 1 to 1,500 psi, the intelligent transmitter module allows for configuration of the 4 to 20 mA signal, display of input or output, and choice of 19 measurement units. The output signal can be adjusted to re-arrange the transmitter or “tare” unwanted fluid head preloads. Rangeability is capable of adjusting zero and span are from -100 to 100% FS URL (Upper Range Limit) with a minimum span of 30% URL. This means a 15 psi transducer can have the zero set between -15 to FS 15 psi. For example, zero could be set for -15 psi and maximum 15 psi so the output would be 4 mA at -15 psi, midpoint 12 mA would be 0 psi and 20 mA would be 15 psi.

**Features**

- **0.075% Accuracy**
- **Linear or Square Root Output**
- **Adjustable Pulsation Dampening**
- **LCD Displays Either Process Variable, mA, or %**
- **Nineteen User Selectable Engineering Units**
- **IP67 316 SS Enclosure**



| Product Number  | Pressure Range        | Pressure Type |
|-----------------|-----------------------|---------------|
| PX3005-25WDWBI  | -25 to 25 inH2O       | Differential  |
| PX3005-160WDWBI | -160 to 160 inH2O     | Differential  |
| PX3005-1KDWBI   | -1,000 to 1,000 inH2O | Differential  |
| PX3005-150DWBI  | -70 to 150 psi        | Differential  |
| PX3005-400DWBI  | -70 to 400 psi        | Differential  |
| PX3005-1.5KDWBI | -70 to 1,500 psi      | Differential  |

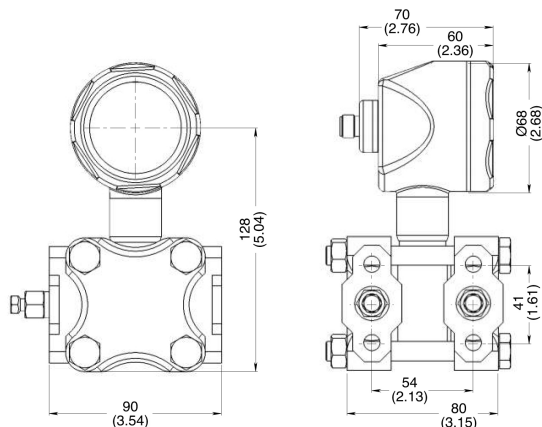

## Specifications

Turndown = nominal range of the device / set span of device

EXAMPLE: a PX3005-1KWDDWBI with set span of 500"H<sub>2</sub>O TD = 1000"H<sub>2</sub>O/500"H<sub>2</sub>O = 2

### Accuracy (NLHR, 20°C ±5°C):

±0.075TD% SPAN  
(Square root output accuracy is 1.5 times linear output accuracy)

### Long Term Stability:

±0.2% URL/60 months

### Ambient Temperature Effects -20 to 80°C (-4 to 176°F):

±(0.1 +0.1TD)% SPAN

### Static Pressure Effects:

Effect on zero ±0.15TD % SPAN/10MPa (1450 psi); Effect

### Power Supply Effects:

± 0.005TD% SPAN/V (Zero and Span)

### Mounting Position Effects:

Install error less than 400Pa (1.60" H<sub>2</sub>O) can be corrected by PV = 0 reset

### Vibration Effects:

GB/T 1827.3/IEC61298-3 tests, 20g (5 to 2000 HZ, max <±3 mm), <0.1% URL

### Supply Voltage:

10.5 to 55VDC

### Output Signal:

4 to 20mA Two wire, linear or square root output selectable

### Sensor Response Time:

200 mS

### Damping Time:

Selectable, 0 to 100 S

### Load Resistance Ω:

<(U-10.5)/0.021

### Transmission Distance:

< 1000m

### Power Consumption:

500mW(20.8mA output @ 24VDC)

### Operating Temperature:

-20 to 70°C (-4 to 160°F)

### Storage Temperature:

-40 to 85°C (-40 to 185°F)

### Media Temperature:

-40 to 120°C (-40 to 250°F)

### Environmental Rating:

IP67

### Media:

Fluids and gasses compatible with 316 SS

### Process Connection/Material:

¼" -18NPT F/316 SS

### Electrical Connection:

4 pin male M12

### Isolating Diaphragm:

316L SS

### Sensor Fill Fluid:

Silicone Oil

### Sensor Seal:

O-ring, FKM

### Housing Material:

316 SS

### Weight:

**Net Weight:** about 3kg (without mounting bracket and process connection adaptor)

## Range Limit Table

| Nominal Value |                   | Minimum Span |                   | UPPER (URL) |                   | LOWER (LRL) |                   | Static Pressure Limit |      | Hi Side Over Range Limit |      | Lo Side Over Range Limit |      |
|---------------|-------------------|--------------|-------------------|-------------|-------------------|-------------|-------------------|-----------------------|------|--------------------------|------|--------------------------|------|
| Mbar          | "H <sub>2</sub> O | Mbar         | "H <sub>2</sub> O | Mbar        | "H <sub>2</sub> O | Mbar        | "H <sub>2</sub> O | Bar                   | Psi  | Bar                      | Psi  | Bar                      | Psi  |
| 60            | 25                | 0.02         | 0.8               | 60          | 25                | -60         | -25               | 250                   | 3600 | 250                      | 3600 | 160                      | 2300 |
| 400           | 160               | 0.04         | 1.6               | 400         | 160               | -400        | -160              | 400                   | 5750 | 250                      | 3600 | 160                      | 2300 |
| 2500          | 1000              | 0.25         | 10                | 2500        | 1000              | -2500       | -1000             | 400                   | 5750 | 250                      | 3600 | 160                      | 2300 |
| Bar           | Psi               | Bar          | Psi               | Bar         | Psi               | Bar         | Psi               | Bar                   | Psi  | Bar                      | Psi  | Bar                      | Psi  |
| 10            | 150               | 0.1          | 1.5               | 10          | 150               | -5          | -70               | 400                   | 5750 | 250                      | 3600 | 160                      | 2300 |
| 30            | 400               | 0.3          | 4                 | 30          | 400               | -5          | -70               | 400                   | 5750 | 250                      | 3600 | 160                      | 2300 |
| 100           | 1500              | 1            | 15                | 100         | 1500              | -5          | -70               | 400                   | 5750 | 250                      | 3600 | 160                      | 2300 |