



LiquiFlo 2.0 AC Drive User Manual

Instruction Manual D2-3518-1

**Rockwell
Automation**

The information in this manual is subject to change without notice.

Throughout this manual, the following notes are used to alert you to safety considerations:



ATTENTION: Identifies information about practices or circumstances that can lead to personal injury or death, property damage, or economic loss.

Important: Identifies information that is critical for successful application and understanding of the product.

The thick black bar shown on the outside margin of this page will be used throughout this instruction manual to signify new or revised text or figures.



ATTENTION: Only qualified electrical personnel familiar with the construction and operation of this equipment and the hazards involved should install, adjust, operate, or service this equipment. Read and understand this manual and other applicable manuals in their entirety before proceeding. Failure to observe this precaution could result in severe bodily injury or loss of life.

ATTENTION: DC bus capacitors retain hazardous voltages after input power has been disconnected. After disconnecting input power, wait five (5) minutes for the DC bus capacitors to discharge and then check the voltage with a voltmeter to ensure the DC bus capacitors are discharged before touching any internal components. Failure to observe this precaution could result in severe bodily injury or loss of life.

ATTENTION: The drive can operate at and maintain zero speed. The user is responsible for assuring safe conditions for operating personnel by providing suitable guards, audible or visual alarms, or other devices to indicate that the drive is operating or may operate at or near zero speed. Failure to observe this precaution could result in severe bodily injury or loss of life.

ATTENTION: Do not install modification kits with power applied to the drive. Disconnect and lock out incoming power before attempting such installation or removal. Failure to observe this precaution could result in severe bodily injury or loss of life.

ATTENTION: The user must provide an external, hardwired emergency stop circuit outside of the drive circuitry. This circuit must disable the system in case of improper operation. Uncontrolled machine operation may result if this procedure is not followed. Failure to observe this precaution could result in bodily injury.

ATTENTION: The drive contains ESD- (Electrostatic Discharge) sensitive parts and assemblies. Static control precautions are required when installing, testing, servicing, or repairing the drive. Erratic machine operation and damage to, or destruction of, equipment can result if this procedure is not followed. Failure to observe this precaution can result in bodily injury.

ATTENTION: The user is responsible for conforming with all applicable local, national, and international codes. Failure to observe this precaution could result in damage to, or destruction of, the equipment.

Profibus is a trademark of Profibus International.

ControlNet is a trademark of ControlNet International Ltd.

DeviceNet is a trademark of the Open DeviceNet Vendor Association

LiquiFlo, VS Utilities, and Reliance are trademarks of Rockwell Automation.

Copyright © 2005 Rockwell Automation. All rights reserved.

CONTENTS

Chapter 1

Introduction

1.1	Firmware Versions.....	1-1
1.2	Manual Conventions.....	1-2
1.3	Getting Assistance from Reliance Electric.....	1-2

Chapter 2

About the Drive

2.1	Identifying the Drive by Assembly Number.....	2-1
2.2	LiquiFlo 2.0 Drive Component Locations.....	2-2
2.2.1	Drive Input Components Locations	2-2
2.2.1.1	Frame 3 Units 180264-A0*	2-2
2.2.1.2	Frame 4 Units 180580-A07 and 180580-A09	2-4
2.2.2	Power Module Component Locations	2-6
2.2.2.1	Frame 3 Units LF200460AAR and LF200608CCR.....	2-6
2.2.2.2	Frame 4 Units LF201215BBR.....	2-9
2.3	Identifying the Power Module by Model Number.....	2-12
2.4	AC Line I/O Board Description (Frame 3 Only)	2-13
2.4.1	Logic Inputs	2-13
2.4.2	Logic Outputs	2-13
2.4.3	Analog Output	2-14
2.5	Standard I/O Board Description (Frame 3 Only)	2-15
2.5.1	Logic Inputs	2-15
2.5.2	Logic Outputs	2-15
2.5.3	Analog Inputs	2-15
2.5.4	Analog Outputs	2-16
2.6	Combined I/O (Frame 4 Only)	2-17
2.6.1	Digital Inputs	2-17
2.6.2	Digital Outputs.....	2-18
2.6.3	Analog Inputs	2-18
2.6.4	Analog Outputs	2-19
2.7	DPI Communication Port	2-19
2.8	Optional Equipment	2-20

Chapter 3

Planning the Installation

3.1	General Requirements for the Installation Site.....	3-1
3.1.1	Making Sure Environmental Conditions are Met.....	3-1
3.1.2	Determining Total Area Required Based on Drive Dimensions	3-2
3.1.3	Verifying the Site Provides for Recommended Air Flow Clearances	3-7
3.1.4	Verifying Power Module Input Ratings Match Supplied Power	3-7
3.2	Wiring Requirements for the Drive	3-7
3.2.1	Determining Wire Size Requirements	3-7
3.2.1.1	Conduit Entry Opening Sizes.....	3-7
3.2.1.2	Recommended Power Wire Sizes	3-7
3.2.1.3	Recommended Control and Signal Wire Sizes.....	3-7
3.2.1.4	Recommended Motor Lead Lengths.....	3-7
3.2.2	Verifying Power Module Output Current Rating Is Greater Than Motor Full Load Amps.....	3-8
3.3	Stopping the Drive	3-8

Chapter 4	Mounting and Grounding the Drive	
	4.1 Lifting and Mounting the Drive	4-1
	4.2 Grounding the Drive	4-2
Chapter 5	Installing Input and Output Power Wiring	
	5.1 Installing Power Wiring from the AC Input Line to the Main Input Circuit Breaker	5-1
	5.2 Installing Wiring from the Power Module Output Terminals to the Motor	5-2
Chapter 6	Completing the Installation	
	6.1 Checking the Installation	6-1
	6.2 Powering Up After Installation Is Complete.....	6-2
Chapter 7	Using the Start-Up Routines	
	7.1 Preparing for Start-Up	7-1
	7.2 Running the Start-Up Routines	7-2
Chapter 8	Programming Basics	
	8.1 About Parameters	8-1
	8.2 How Parameters are Organized.....	8-2
	8.3 Accessing the Parameters	8-3
	8.3.1 Viewing Rectifier Parameters	8-4
	8.4 Selecting the Parameter Access Level	8-4
	8.5 Ensuring Program Security	8-5
Chapter 9	Parameter Descriptions	
	9.1 Inverter Parameters	9-2
	9.2 Rectifier Parameters	9-9
Chapter 10	Troubleshooting the Drive	
	10.1 Verifying that DC Bus Capacitors are Discharged Before Servicing the Drive	10-1
	10.2 Determining Drive Status Using the Status LEDs	10-2
	10.3 About Alarms.....	10-5
	10.3.1 Alarm Descriptions.....	10-6
	10.4 About Faults	10-8
	10.4.1 About the Fault Queue.....	10-9
	10.4.2 Clearing Faults.....	10-9
	10.4.3 Fault Descriptions and Corrective Actions.....	10-9
	10.4.3.1 Frame 3 Fault Descriptions and Corrective Actions	10-10
	10.4.3.2 Frame 4 Fault Descriptions and Corrective Actions	10-19
	10.5 Diagnostic Parameters.....	10-29
	10.6 Common Symptoms and Corrective Actions	10-29
	10.7 Replacement Parts.....	10-34
	10.8 Troubleshooting the Drive Using the LCD OIM	10-37
	10.8.1 Accessing the Fault Queue.....	10-38
	10.8.2 Accessing the Fault Parameters.....	10-39
	10.8.3 Accessing the Drive Status Parameters	10-39
	10.8.4 Determining the Product Version.....	10-40
	10.8.4.1 Device Version	10-40

10.8.4.2 OIM Version 10-41
10.8.4.3 Device Items 10-42
10.8.5 Contacting Tech Support for Assistance 10-42

www.rgbautomatyka.pl

List of Figures

Figure 2.1 – Identifying the Drive by Assembly Number.....	2-1
Figure 2.2 – Drive Input Components (Frame 3).....	2-3
Figure 2.3 – Drive Components (Frame 4).....	2-5
Figure 2.4 – Power Module Component Locations - Door Open (Frame 3).....	2-7
Figure 2.5 – Power Module Component Locations - Door Closed (Frame 3).....	2-8
Figure 2.6 – Power Module Component Locations - IO and Control Panel Removed (Frame 4).....	2-10
Figure 2.7 – Power Module Component Locations - Front Panel Removed (Frame 4).....	2-11
Figure 2.8 – Identifying the Drive Model Number.....	2-12
Figure 2.9 – AC Line I/O Board (Frame 3).....	2-14
Figure 2.10 – Standard I/O Board.....	2-16
Figure 2.11 – Combined I/O (Frame 4).....	2-17
Figure 2.12 – DPI Communication Interface Board (Frame 3).....	2-20
Figure 2.13 – Power Module Bottom Left Front View (Frame 4).....	2-20
Figure 3.1 – Exterior Enclosure Dimensions - Frame 3.....	3-3
Figure 3.2 – Power Module Dimensions - Frame 3.....	3-4
Figure 3.3 – Exterior Enclosure Dimensions - Frame 4.....	3-5
Figure 3.4 – Exterior Enclosure Dimensions - Frame 4.....	3-6
Figure 4.1 – Lift Point Locations for LiquiFlo 2.0 Drives (Frame 3).....	4-1
Figure 4.2 – Lift Point Locations for LiquiFlo 2.0 Drives (Frame 4).....	4-2
Figure 7.1 – Accessing the Start-Up Routines.....	7-2
Figure 7.2 – Start-Up Menu.....	7-2
Figure 8.1 – Example of Parameter Organization.....	8-2
Figure 8.2 – Accessing the Parameters Using the LCD OIM.....	8-3
Figure 8.3 – Selecting the Active Rectifier.....	8-4
Figure 8.4 – Selecting the Parameter Access Level.....	8-4
Figure 8.5 – Setting the Write-Protect Password.....	8-5
Figure 9.1 – Appl Digital Output (30).....	9-7
Figure 9.2 – Appl Digital Output (30) Frame 4.....	9-7
Figure 9.3 – Rectifier Control (33).....	9-9
Figure 9.4 – Rectifier Control (33) Frame 4.....	9-9
Figure 9.5 – Rectifier Status (34).....	9-10
Figure 9.6 – Speed Limits.....	9-14
Figure 9.7 – Compensation (56).....	9-15
Figure 9.8 – Speed Limits.....	9-20
Figure 9.9 – Trim Out Select (118).....	9-26
Figure 9.10 – PI Configuration (124).....	9-27
Figure 9.11 – PI Control (125).....	9-29
Figure 9.12 – PI Status (134).....	9-33
Figure 9.13 – Save OIM Ref (192).....	9-44
Figure 9.14 – Save MOP Ref (194).....	9-45
Figure 9.15 – Drive Status 1 (209).....	9-48
Figure 9.16 – Drive Status 2 (210).....	9-49
Figure 9.17 – Drive Alarm 1 (211).....	9-50
Figure 9.18 – Drive Alarm 2 (212).....	9-50
Figure 9.19 – Start Inhibits (214).....	9-51
Figure 9.20 – Dig In Status (216).....	9-52
Figure 9.21 – Dig Out Status (276).....	9-53

Figure 9.22 – Status 1 @ Fault (227).....	9-55
Figure 9.23 – Status 2 @ Fault (228).....	9-55
Figure 9.24 – Alarm 1 @ Fault (229).....	9-56
Figure 9.25 – Alarm 2 @ Fault (230).....	9-56
Figure 9.26 – Fault Config 1 (238).....	9-58
Figure 9.27 – Alarm Config 1 (259).....	9-60
Figure 9.28 – Drive Logic Rslt (271).....	9-61
Figure 9.29 – Logic Mask (276).....	9-62
Figure 9.30 – Stop Owner.....	9-65
Figure 9.31 – Anlg In Config (320).....	9-70
Figure 9.32 – Anlg in Sqr Root (321).....	9-71
Figure 9.33 – Analog Out Config.....	9-73
Figure 9.34 – Anlg Out Absolute (341).....	9-74
Figure 9.35 – Rectifier Control Word (Rectifier 100) Frame 3.....	9-97
Figure 9.36 – Rectifier Control Word (Rectifier 100) Frame 4.....	9-97
Figure 9.37 – Rectifier Status Word (Rectifier 101).....	9-98
Figure 10.1 – Location of DC Bus Measuring Points (Frame 3).....	10-2
Figure 10.2 – Location of DC Bus Measuring Points (Frame 4).....	10-2
Figure 10.3 – Location of the Status LEDs (Frame 3).....	10-3
Figure 10.4 – Location of the Status LEDs (Frame 4).....	10-4
Figure 10.5 – Sample Fault Screen on the LCD OIM.....	10-8
Figure 10.6 – Accessing the Fault Queue.....	10-38
Figure 10.7 – Sample Fault Queue Entry.....	10-38
Figure 10.8 – Accessing the Fault Parameters.....	10-39
Figure 10.9 – Accessing the Drive Status Parameters.....	10-39
Figure 10.10 – Accessing the Device Version Information.....	10-40
Figure 10.11 – Device Version Screens at Product and Component Levels.....	10-40
Figure 10.12 – Accessing the OIM Version Information.....	10-41
Figure 10.13 – OIM Version Screens at the Product and Component Levels.....	10-41
Figure 10.14 – Accessing the Device Item Information.....	10-42

List of Tables

Table 1.1 – Firmware Versions.....	1-1
Table 2.1 – Drive Assembly and Power Module Ratings.....	2-12
Table 2.2 – Available Kits and Options.....	2-20
Table 3.1 – Environmental Conditions.....	3-2
Table 5.1 – Minimum Motor Lead Wire Size.....	5-2
Table 9.1 – Appl Analog Output (31) usable range and default.....	9-8
Table 9.2 – Default Values for Preset Speeds 1-7	9-25
Table 9.3 – Analog Output Scaling.....	9-75
Table 9.4 – Speed Select Inputs.....	9-81
Table 9.5 – Default Values for Parameters 361-366	9-81
Table 9.6 – Drive Response to Jog Forward and Jog Reverse Inputs	9-83
Table 9.7 – Effect of Speed Select Input State on Selected Reference	9-84
Table 10.1 – Inverter Status LED Definitions.....	10-4
Table 10.2 – Rectifier Status LED Definitions.....	10-4
Table 10.3 – Status LED Definitions for Hardware Failure	10-5
Table 10.4 – Types of Alarms.....	10-5
Table 10.5 – Alarm Descriptions.....	10-6
Table 10.6 – Alarm Names Cross-Referenced by Alarm Numbers	10-7
Table 10.7 – Fault Types.....	10-8
Table 10.8 – Fault Descriptions and Corrective Actions (Frame 3)	10-10
Table 10.9 – Fault Descriptions and Corrective Actions (Frame 4)	10-19
Table 10.10 – Fault Names Cross-Referenced by Fault Number.....	10-28
Table 10.11 – Test Point Codes and Functions.....	10-29
Table 10.12 – Drive Does Not Start From Start, Run, or Jog Inputs Wired to the Terminal Block.....	10-29
Table 10.13 – Drive Does Not Start or Jog From OIM.....	10-31
Table 10.14 – Drive Does Not Respond to Changes in Speed Command.....	10-32
Table 10.15 – Motor and/or Drive Will Not Accelerate to Commanded Speed.....	10-32
Table 10.16 – Motor Operation is Unstable	10-33
Table 10.17 – Drive Will Not Reverse Motor Direction	10-33
Table 10.18 – Stopping the Drive Results in a Decel Inhibit Fault.....	10-33
Table 10.19 – LiquiFlo 2.0 Drive Replacement Parts (Frame 3 Only)	10-34
Table 10.20 – LiquiFlo 2.0 Power Module Replacement Parts (Frame 3 Only) ...	10-35
Table 10.21 – LiquiFlo 2.0 Drive Replacement Parts (Frame 4 Only)	10-36
Table 10.22 – LiquiFlo 2.0 Power Module Replacement Parts (Frame 4 Only) ...	10-37

www.rgbautomatyka.pl

CHAPTER 1

Introduction

This manual is intended for qualified electricians and pipe fitters familiar with installing, programming, and maintaining AC drives.

This manual contains information on:

- Installing and wiring the LiquiFlo 2.0 AC drive
- Programming the drive
- Troubleshooting the drive

The latest version of this manual is available from <http://www.theautomationbookstore.com> or http://www.reliance.com/docs_onl/online_stdrv.htm.

1.1 Firmware Versions

There are two different frame types for Liquiflo 2.0 drives, called “Frame 3” and “Frame 4”. See chapter 2 for a description of the physical layout, components, and ratings for each frame type.

Each drive contains two sections - the “inverter” section and the “rectifier” section. Each section contains its own firmware. Drive firmware for frame 3 drives has version numbers in the 1.x series, and drive firmware for frame 4 drives has version numbers in the 2.x series.

The current drive firmware versions as of the date of publication of this manual are as follows:

Table 1.1 – Firmware Versions

Firmware	Current Version
Frame 3 inverter application firmware	1.7
Frame 3 rectifier application firmware	1.6
Frame 4 inverter application firmware	2.2
Frame 4 rectifier application firmware	2.2

If firmware version updates alter information in this manual, Reliance Electric will publish an errata sheet to provide the additional information.

See section 11.8.4 for instructions on determining the version numbers for firmware currently installed in a drive.

1.2 Manual Conventions

Parameter names: In most instances, parameter names are shown as the parameter name followed by the parameter number. The parameter name will be preceded by inverter or rectifier for reference.

For example: inverter PI Control (125).

1.3 Getting Assistance from Reliance Electric

If you have any questions or problems with the products described in this instruction manual, contact your local Reliance Electric sales office.

For technical assistance, call 1-800-726-8112. Before calling, please review the troubleshooting section of this manual and check the standard drives website for additional information. When you call this number, you will be asked for the drive model number and this instruction manual number.

CHAPTER 2

About the Drive

This chapter describes how to identify the drive assembly, power module and shows the major drive components.

The LiquiFlo 2.0 AC drive is a PWM (pulse-width-modulated) liquid-cooled drive that provides vector and general purpose regulation for a wide range of applications.

2.1 Identifying the Drive by Assembly Number

Each LiquiFlo 2.0 AC drive can be identified by its cabinet assembly ID number or cabinet assembly serial number. See figure 2.1. These numbers appear on the shipping label and on the drive cabinet nameplate.

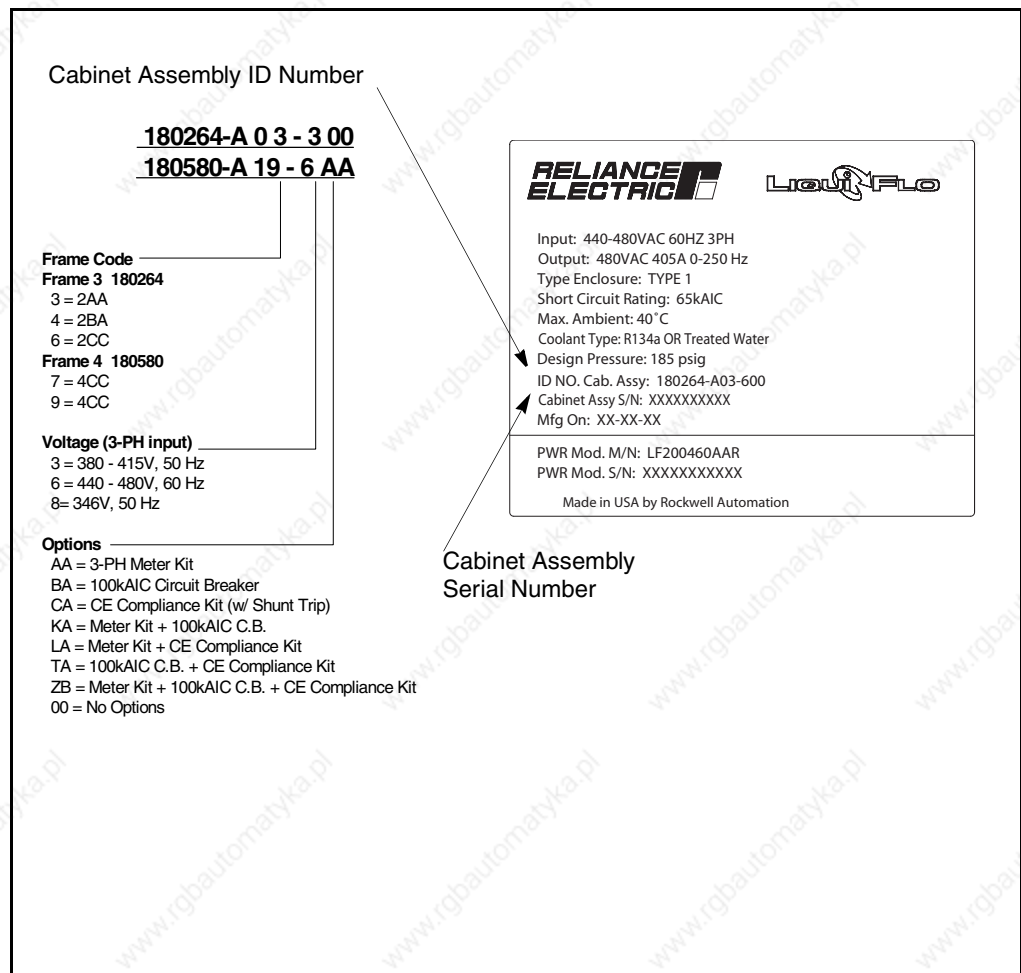

Figure 2.1 – Identifying the Drive by Assembly Number

2.2 LiquiFlo 2.0 Drive Component Locations

LiquiFlo 2.0 AC drives comprise a drives components section and a power module section. Sections 2.2.1 and 2.2.2 list and illustrate the components in each section of the drive.

2.2.1 Drive Input Components Locations

2.2.1.1 Frame 3 Units 180264-A0*

The input components section contains the following main components. The numbered items listed below provided correspond to the numbers used in figure 2.2. Replacement parts are listed in chapter 10.

1. AC Contactor (3) with Surge Suppressor
2. Terminal Block, 6-Position
3. Precharge Resistors (3)
4. Power Module Assembly
5. Power Module Nameplate
6. Fuse Block, 30 A, 600 V, Class CC, 3-Line
7. Fuse, Class CC, 600 V, 1 A
8. Fuse, Class CC, 600 V, 20 A
9. Line Sync. PC Board Assembly
10. Line Sync. Board Cover
11. Plastic Knob
12. 115 V Fan, 6" dia. (2)
13. Capacitor Guard Panel
14. Capacitor Bank Assembly
15. Fuse Block, 30 A, 600 V, Class CC
16. Fuse, Class CC, 600 V, 5 A
17. Fuse, Class CC, 600 V, 25 A
18. Fuse Holder, 600 V, 30 A
19. Fuse, Class RK5, 600 V, 15 A
20. Transformer, 3 kVA
21. Resistor, 100 kOhm, 50 W
22. Operating Mechanism, Complete Kit
23. Main Input Circuit Breaker
24. Ground Lug, 2-600 MCM
25. 115 V Fan, 5" sq.
26. Air Filter
27. Floor Mounting Kit (3)

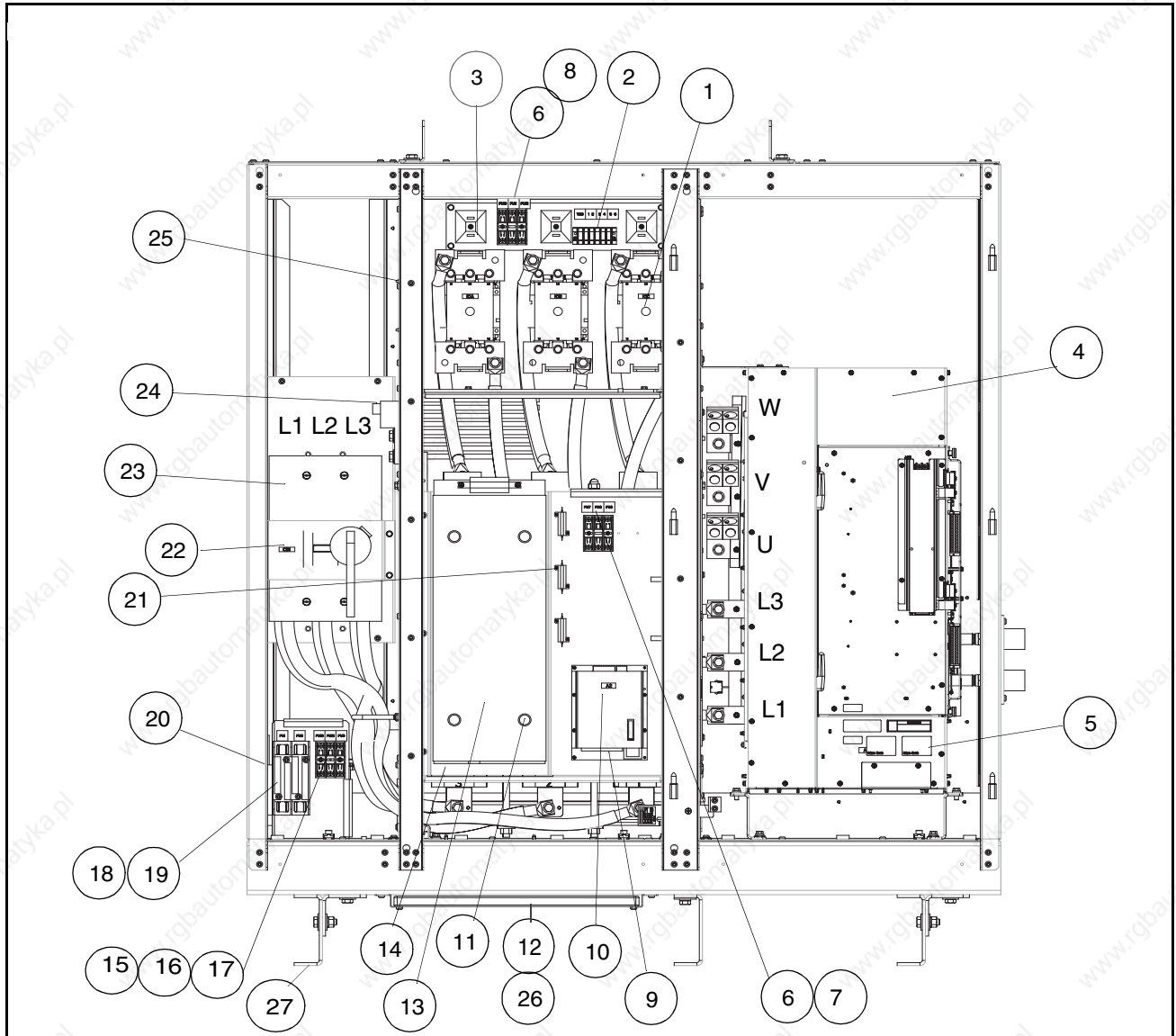

Figure 2.2 – Drive Input Components (Frame 3)

2.2.1.2 Frame 4 Units 180580-A07 and 180580-A09

The drive components section contains the following main components. The numbered items listed below provided correspond to the numbers used in figure 2.3. Replacement parts are listed in chapter 10.

1. Circuit Breaker, 600V
2. Circuit Breaker Operating Mechanism
3. Inductor
4. AC Contactor
5. Power Module Assembly
6. Input Filter Capacitor Assembly
7. Input Filter Capacitor Guard Panel
8. Fans, 115VAC, Inductor (4)
9. Transformer, 3kVA
10. Fan, 115VAC, Contactor
11. Resistors, 100k Ohms, 50W
12. Precharge Resistors
13. Relay, Oil Pump & Control Power Terminals
14. Fuse, Class RK-5, 600V, 10A (2)
15. Fuse, Class CC, 600V, 25A (1)
16. Fuse, Class CC, 600V, 10A (1)
17. Fuse, Class T, 600V, 300A (3)
18. Fuse, Class CC, 600V, 20A (3)
19. Fuse, Class CC, 600V, 1A (3)
20. Ground Lug, 2-600 MCM
21. Nameplate, Power Module
22. Door Inter-lock (2)

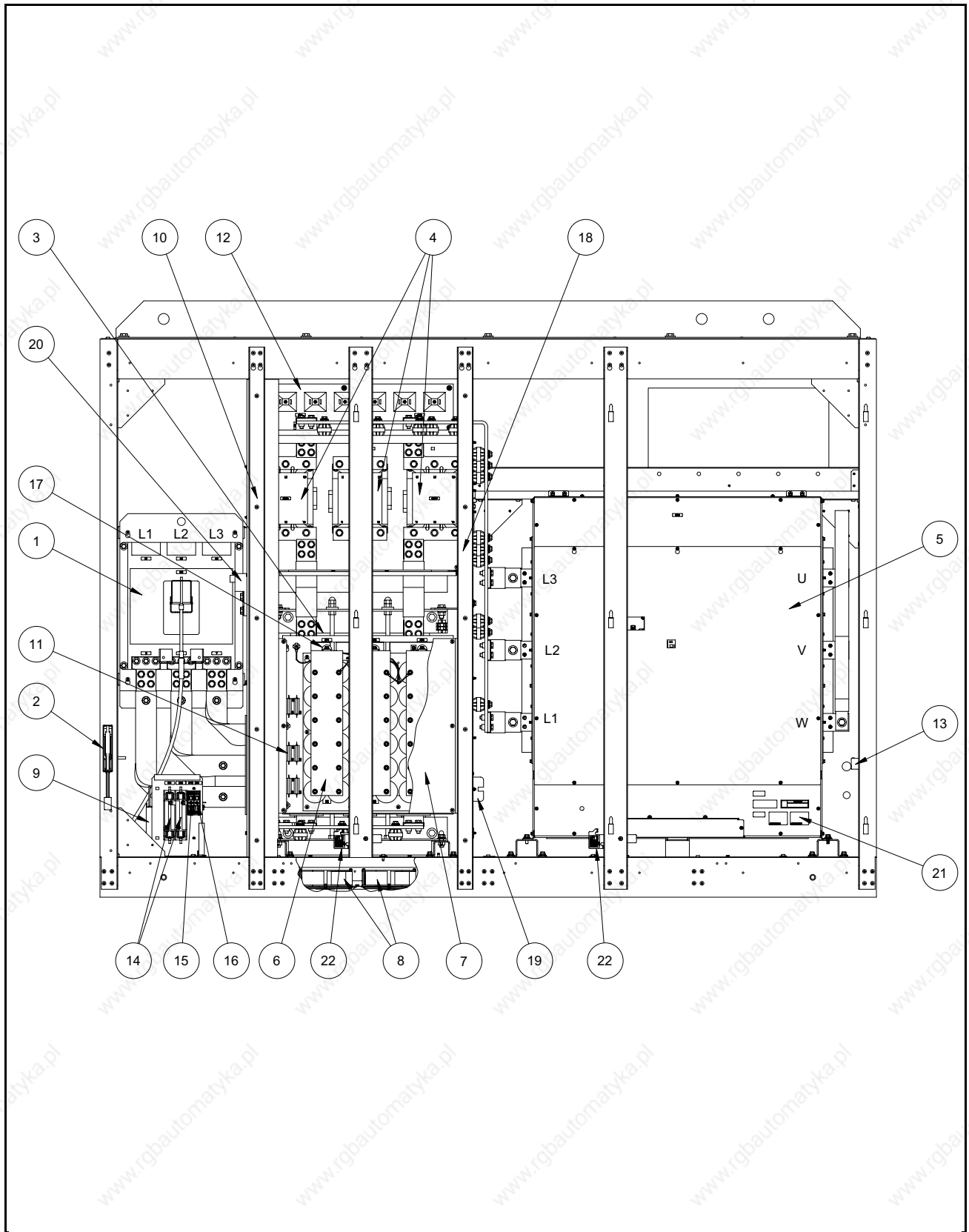

Figure 2.3 – Drive Components (Frame 4)

2.2.2 Power Module Component Locations

2.2.2.1 Frame 3 Units LF200460AAR and LF200608CCR

The power module section contains the following main components. The numbered items listed below provided correspond to the numbers used in figures 2.4 and 2.5. Replacement parts are listed in chapter 10.

1. Wire Harness Assembly, Power Supply, Logic (2)
2. Current Feedback Device, 1000 A (6)
3. Terminal Block, 2-Position
4. 80 W Power Supply Assembly (2)
5. Cable Assembly, 40-pin, 0.050 in Pitch, Flex Film (2)
6. Cable Assembly, 30-pin, 0.050 in Pitch, Flex Film (2)
7. Wire Harness Assembly, Power Supply, Upper Gate (2)
8. Inverter Power Interface Assembly
9. Wire Harness Assembly, Power Supply, Lower Gate (2)
10. Insulation Sheet (2)
11. Communications Interface Assembly
12. Rectifier Power Interface Assembly
13. Wire Harness Assembly, Gate Driver
14. Wire Harness Assembly, Current Feedback Device
15. Wire Harness Assembly, Line Sync.
16. Wire Harness Assembly, DC Bus Bleeder Resistors
17. Cable Assembly, 20-pin, 0.050 in Pitch, Flex Film (optional)
18. Communications Assembly (optional)
19. Internal Fan
20. Connector, Terminal Block, 32-pin
21. AC Line I/O Assembly
22. Rectifier Control Assembly
23. Inverter Control Assembly
24. Standard I/O Assembly
25. Wire Harness Assembly, Control Sync.

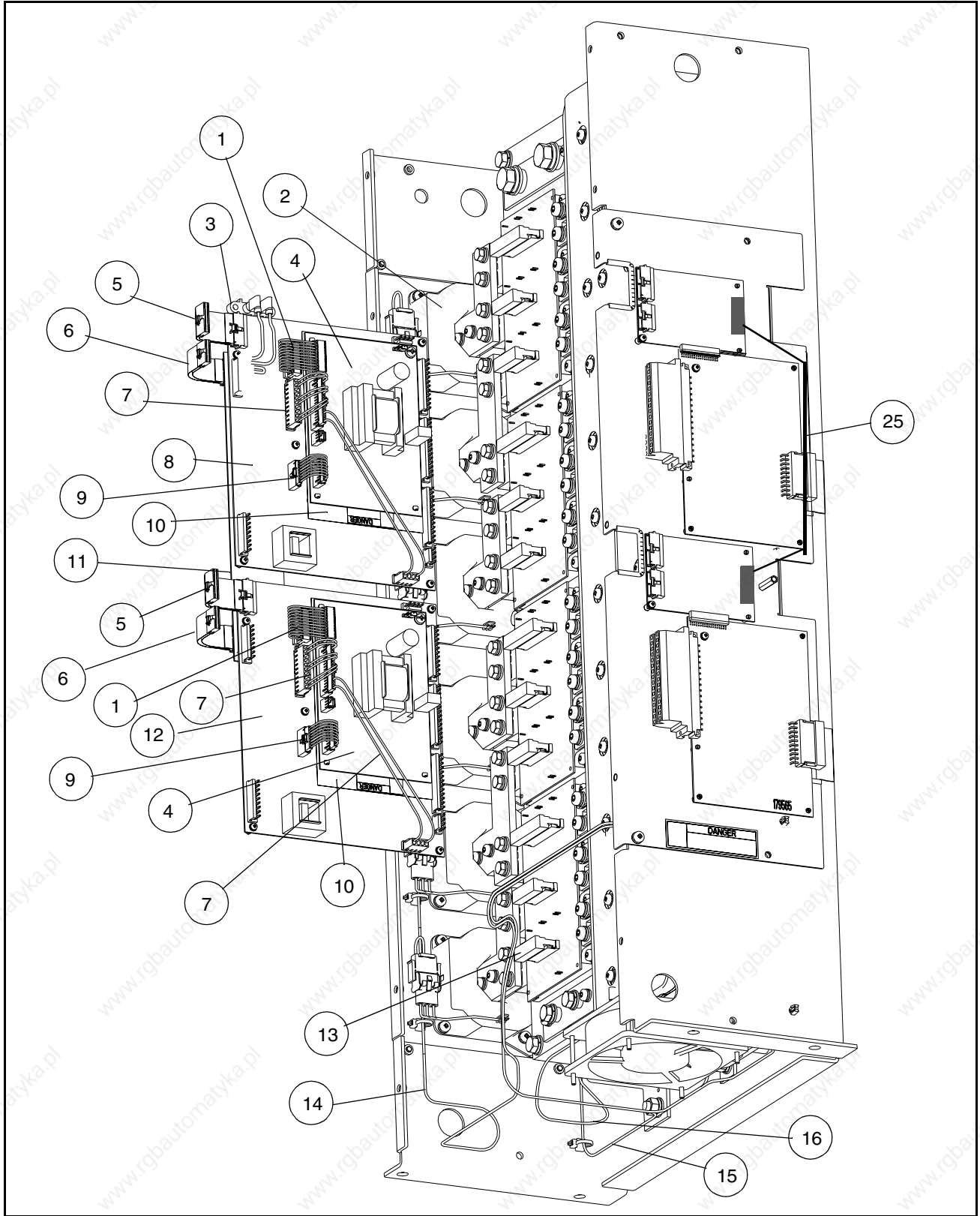

Figure 2.4 – Power Module Component Locations - Door Open (Frame 3)

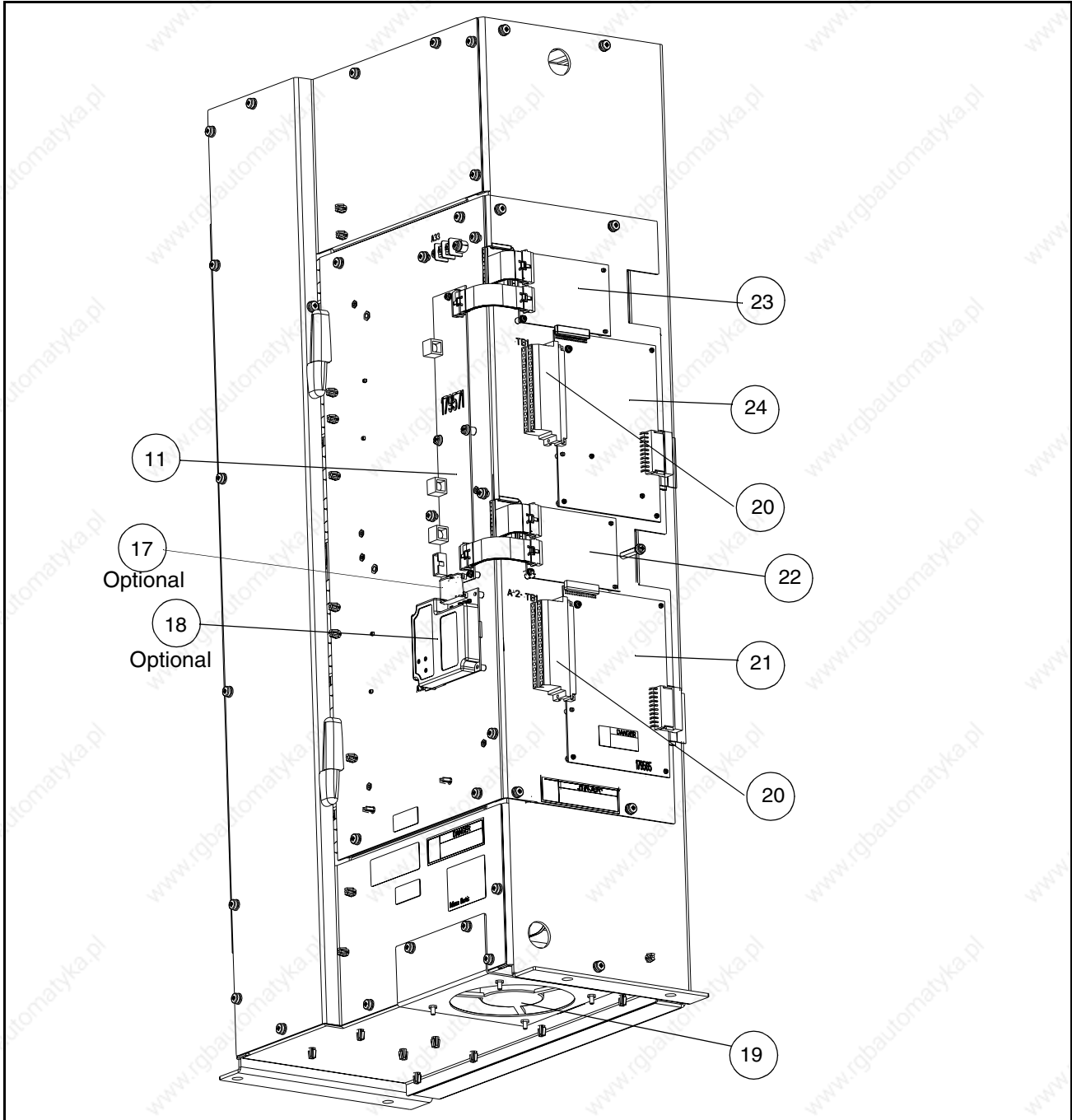

Figure 2.5 – Power Module Component Locations - Door Closed (Frame 3)

2.2.2.2 Frame 4 Units LF201215BBR

The power module section contains the following main components. The numbered items listed below provided correspond to the numbers used in figures 2.6 and 2.7. Replacement parts are listed in chapter 11.

1. Combined Power PCB Assembly, 810 Amps
Combined Power PCB Assembly, 1215 Amps
2. Wire Harness Assembly, Gate Driver
3. Internal Fan, 24 VDC
4. Internal Fan, 24 VDC
5. Wire Harness Assembly, Internal Fan
6. Wire Harness Assembly, DC Power
7. Wire Harness Assembly, DC Bus Resistors
8. Current Feedback Device, 2000A
9. Wire Harness Assembly, Current Feedback Device, Rectifier Side
10. Wire Harness Assembly, Current Feedback Device, Inverter Side
11. Wire Harness Assembly, RTD, Rectifier Side
12. Wire Harness Assembly, RTD, Inverter Side
13. Cable Assembly, 40-Pin
14. Combined Control PCB Assembly
15. Combined I/O PCB Assembly
16. RS-485 Communications Assembly
17. Cable Assembly, 20-Pin
18. Cable, Mini DIN, 8 Pos., Male/Male, 1 Meter Long

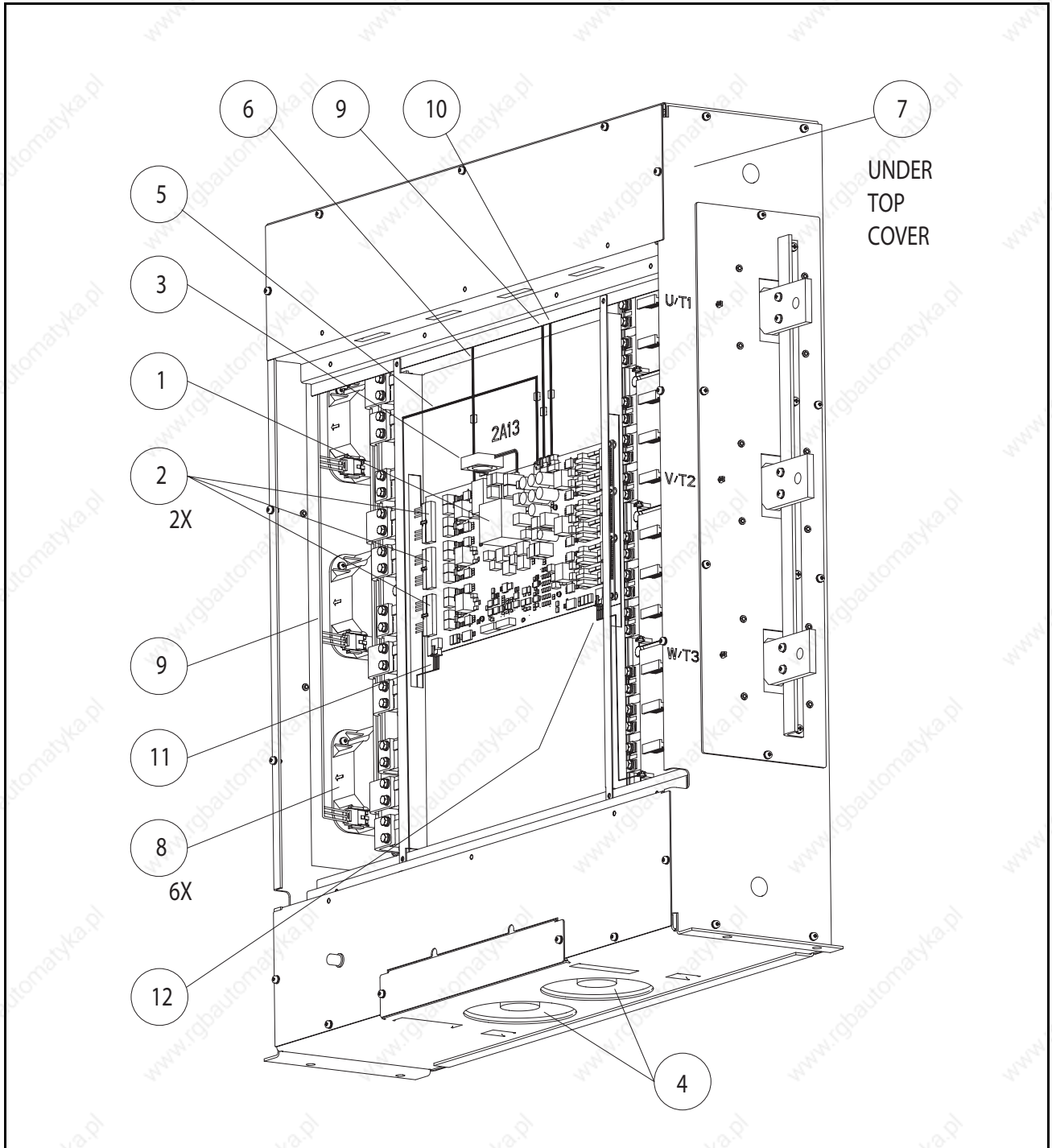

Figure 2.6 – Power Module Component Locations - IO and Control Panel Removed (Frame 4)

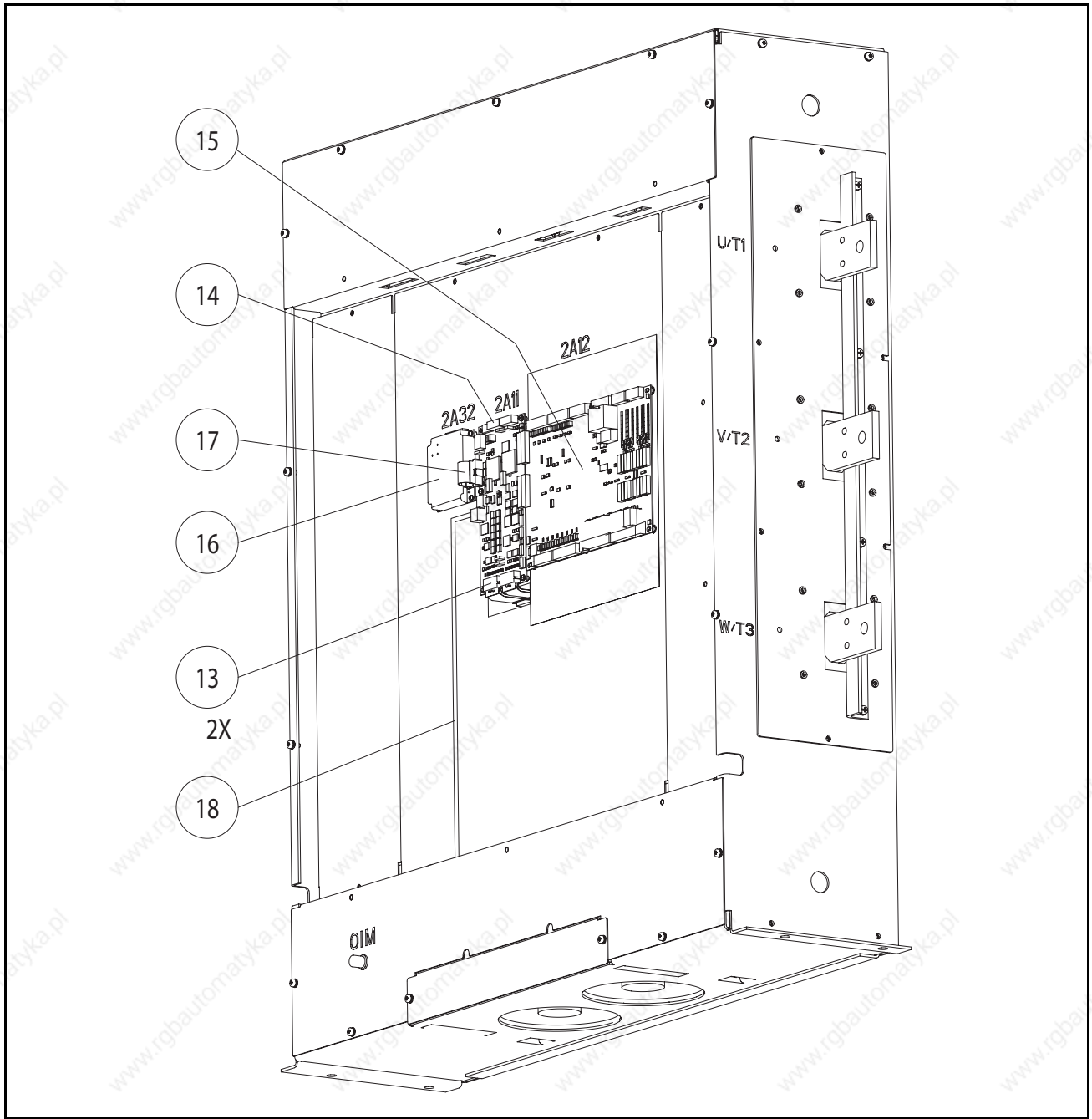

Figure 2.7 – Power Module Component Locations - Front Panel Removed (Frame 4)

2.3 Identifying the Power Module by Model Number

Each LiquiFlo 2.0 AC power module can be identified by its model number. See figure 2.8. This number appears on the shipping label and on the power module's nameplate. Power ratings are provided in table 2.1.

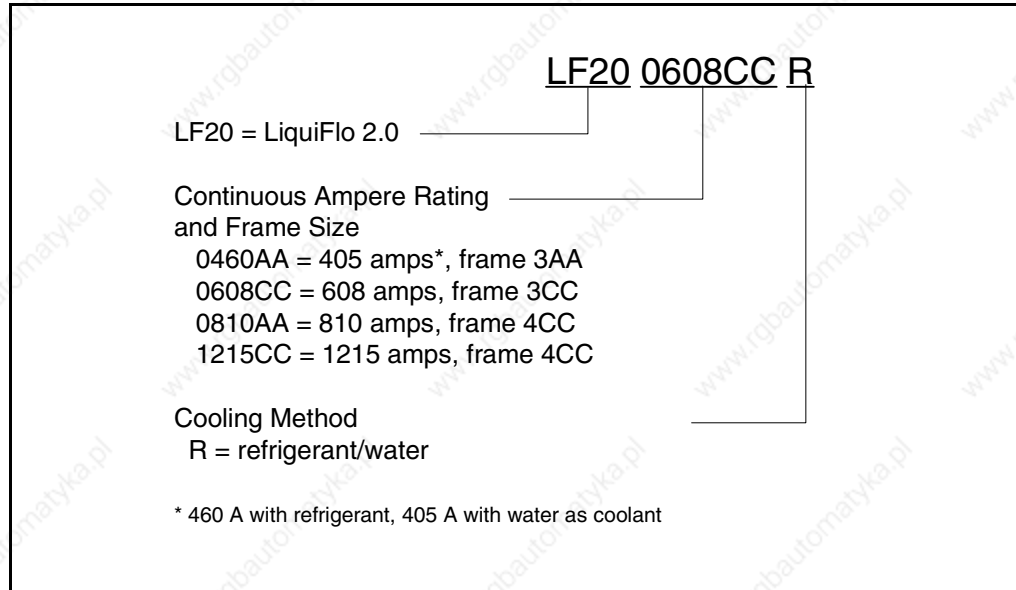

Figure 2.8 – Identifying the Drive Model Number

Table 2.1 – Drive Assembly and Power Module Ratings

Drive Assembly ID Number	Power Module Model Number	Frame Size	Enclosure Rating	Input Power (KVA)	Input Voltage (V)	Input Current ¹ (Amps)	Output Current at 2 kHz ² (Amps)
180264-A03	LF200460AAR	Frame 3AA	NEMA 1	337	480 ±10%	405	405
180264-A06	LF200608CCR	Frame 3CC	NEMA 1	505	480 ±10%	608	608
180580-A07	LF201215CCR	Frame 4CC	NEMA 1	673	480 ±10%	810	810
180580-A09 ³	LF201215CCR	Frame 4CC	NEMA 1	1010	480 ±10%	1215	1215

¹460 A with refrigerant, 405 A with water as coolant.

²110% output current capability for one minute, 150% output current capability for 5 sec.

³No overload rating for 180580-A09. 100% output current capability.

2.4 AC Line I/O Board Description (Frame 3 Only)

The following signals are available at the AC Line I/O board terminal block. The AC Line I/O board is labeled as item 7 in figure 2.4. Refer to figure 2.9 for terminal identification.

2.4.1 Logic Inputs

The AC Line I/O board terminal block provides terminals for four logic inputs (terminals 22 to 26). These logic inputs cannot be configured.

2.4.2 Logic Outputs

The AC Line I/O board terminal provides terminals for 6 logic outputs that are non user-configurable terminals 5 to 16 and 27 to 32. The state of these 6 outputs can be changed by writing to inverter parameter #30 Appl Digital Out. Logic output 1 is always connected to the shunt trip circuit and should not be used for anything else.

All six digital output devices are from C relays capable of switching 250 VAC at eight amps or 30 VDC at eight amps.

2.4.3 Analog Output

The AC Line I/O board terminal block provides terminals for two special purpose analog outputs, using terminals 1-2 and 17-18. These outputs are not user-configurable.

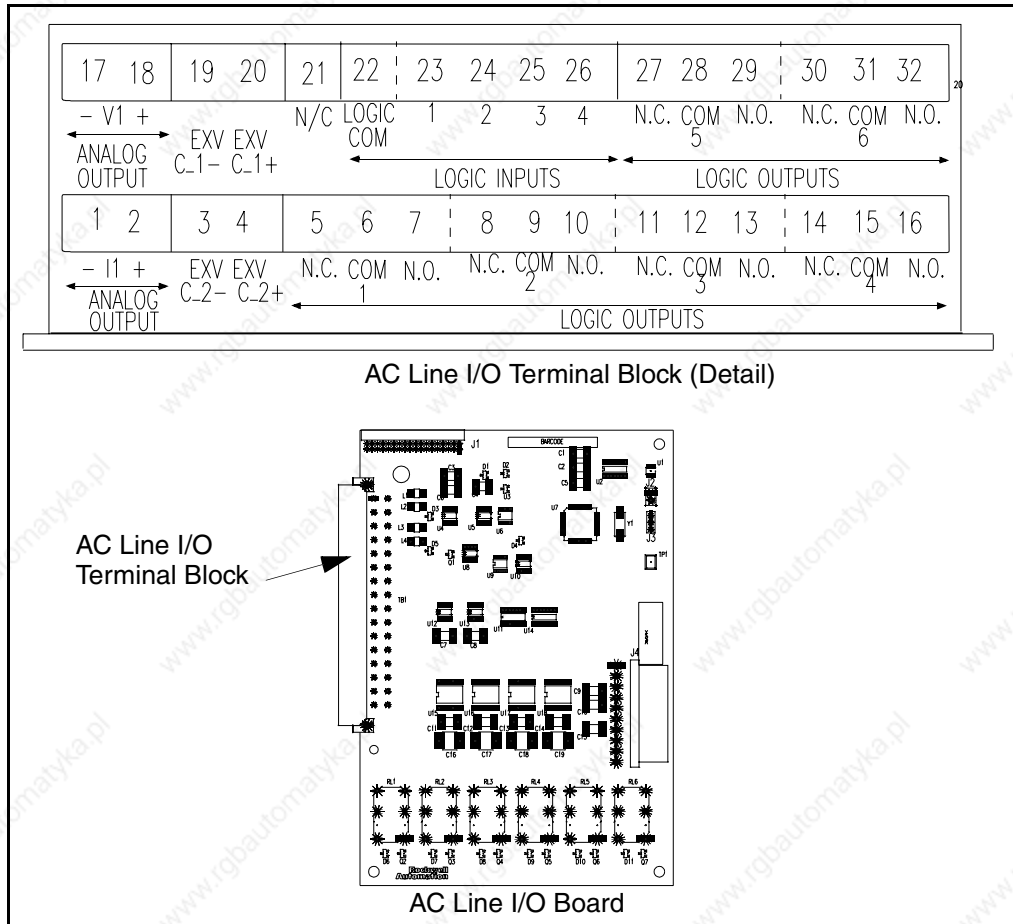

Figure 2.9 – AC Line I/O Board (Frame 3)

2.5 Standard I/O Board Description (Frame 3 Only)

The following signals are available at the Standard I/O board terminal block. The Standard I/O board is labeled as item 24 in figure 2.5. Refer to figure 2.10 for terminal identification.

2.5.1 Logic Inputs

The Standard I/O board terminal block provides terminals for six logic inputs (terminals 27 through 32). The logic terminals are configured using the inverter digital input select parameters (361-366).

2.5.2 Logic Outputs

The Standard I/O board terminal block provides terminals for two logic outputs. (terminals 11 to 16). These logic outputs can be configured for any of the 30 functions controlled by Digital Out1 Sel (380) and Digital Out2 Sel (384).

The logic output devices are form C relays capable of switching 250 VAC at eight amps to 30 VDC at eight amps.

2.5.3 Analog Inputs

The standard I/O board terminal block provides terminals for two user-configurable analog inputs, using terminals 1-4 and 17-20. The inputs are configurable using inverter parameters 320 (Anlg In Config) through 327 (Analog In 2 Loss). Each analog input has two modes: voltage-sensing (input senses -10V to +10V) and current-sensing (input senses 0 mA to 20 mA). Separate terminals on the standard I/O board are used for each mode. The mode for both inputs are selected via inverter parameter #320 (Anlg In Cnfg). In this parameter, if the bit corresponding to a particular analog input is set (i.e. has a value of 1), then the analog input is in current-sensing mode; otherwise, it is in voltage-sensing mode.

The following table describes the correspondence between the mode of each user-configurable analog input and the standard I/O board terminals that should be used.

Input and Mode	Paramter #30 Setting	Terminal Designators	Terminal Numbers
Analog input 1, voltage-sensing	Bot 0 = 0	V1+, V1-	1, 2
Analog input 1, current-sensing	Bit 0 = 1	I1+, I2-	17, 18
Analog input 2, voltage-sensing	Bit 1 = 0	V2+, V2-	3, 4
Analog input 2, current-sensing	Bit 1 = 1	I1+, I2-	19, 20

2.5.4 Analog Outputs

The single analog output channel can be configured using Analog Out Config (340) and Analog Out1 Sel (342) to select any one of 31 analog outputs. Terminals 8 and 9 output 4 to 20 mA. Terminals 6 and 7 output 0 to 10 volts.

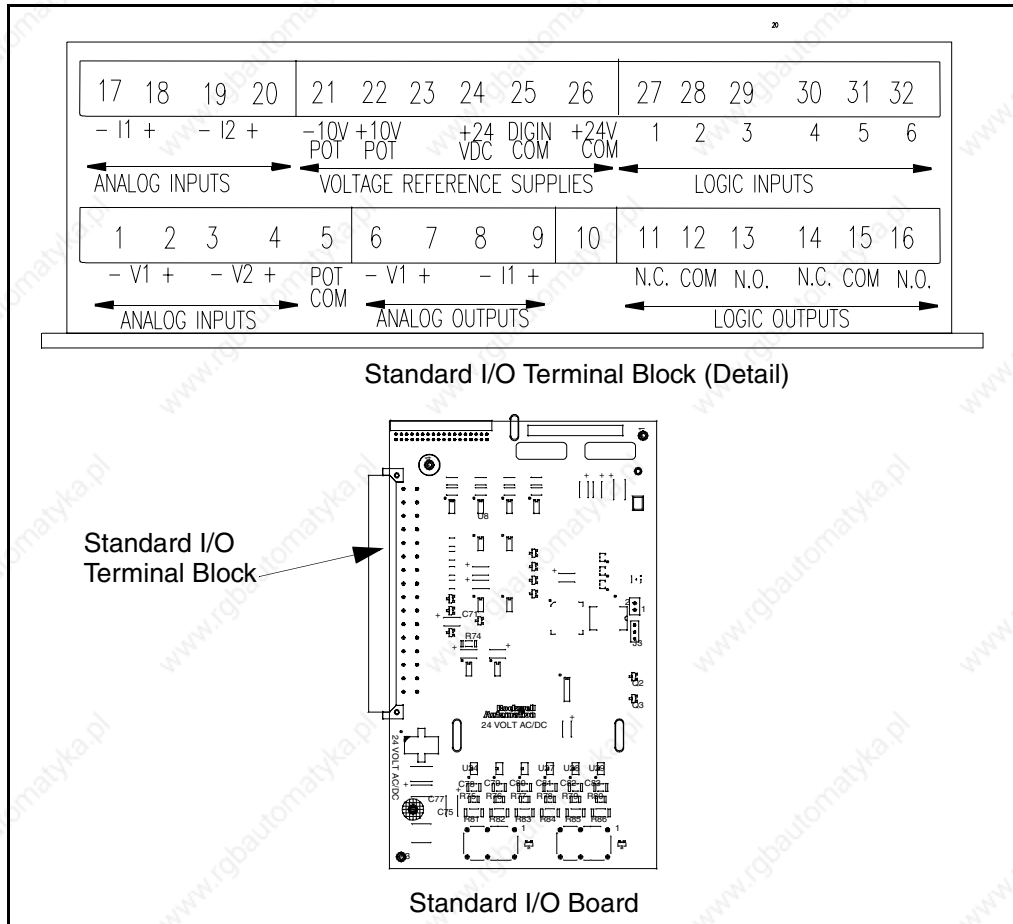

Figure 2.10 – Standard I/O Board

2.6 Combined I/O (Frame 4 Only)

Figure 2.11 shows terminal block locations on the Combined I/O Board.

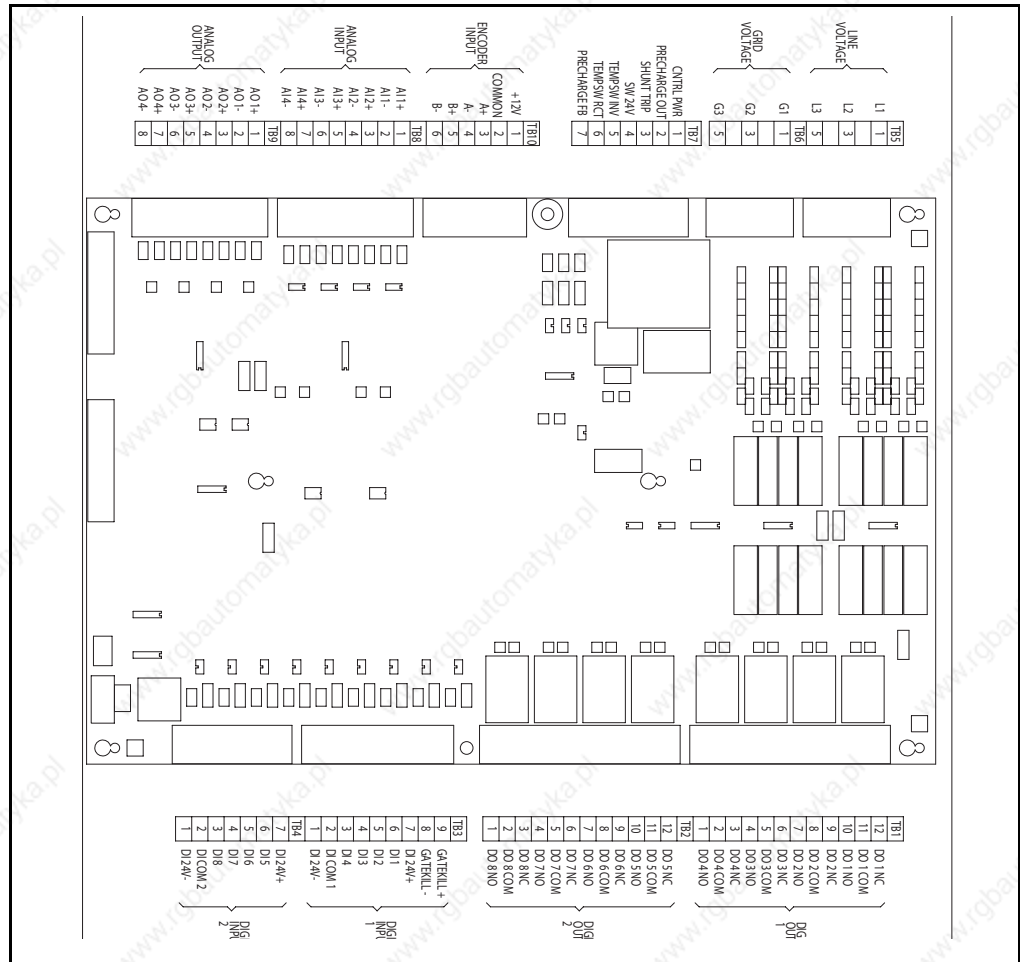

Figure 2.11 – Combined I/O (Frame 4)

2.6.1 Digital Inputs

The combined I/O board contains hardware for six user-configurable digital inputs, using connector positions designated DI3 through DI8. The following table shows the correspondence between the digital input and the inverter parameter used to configure it.

Inverter Parameter Number	Inverter Parameter Name	Connector Position Designator
361	Digital In1 Sel	DI3
362	Digital In2 Sel	DI4
363	Digital In3 Sel	D15
364	Digital In4 Sel	DI6
365	Digital In5 Sel	DI7
366	Digital In6 Sel	DI8

The states of all six user-configurable digital inputs are visible in inverter parameter Dig In Status (216).

The digital inputs that use connector positions DI1 and DI2 on the combined I/O board are not user-configurable. The status of these two digital inputs are visible in rectifier parameter Dig In Status (216).

2.6.2 Digital Outputs

The combined I/O board contains two user-configurable digital outputs, using connector positions designated DO1 and DO2. These two digital outputs are configured using inverter parameters Digital Out1 Sel through Digital Out2 OffTime (380-387).

The combined I/O board contains six special purpose digital outputs, using connector positions designated DO3 through DO8. The state of these six outputs can be changed by writing to inverter parameter Appl Digital Out (30).

All eight digital output devices are form C relays capable of switching 250VAC at 8 Amps or 30VDC at 8 Amps.

The combined I/O board also contains dedicated terminals for driving the shunt trip circuit.

2.6.3 Analog Inputs

The combined I/O board contains two user-configurable analog inputs. The inputs are configurable using inverter parameters Anlg In Config through Analog In 2 Loss (320-327). Each analog input has two modes: voltage-sensing (input senses -10V to +10V) and current-sensing (input senses 0 mA to 20 mA). Separate terminals on the combined I/O board are used for each mode. The mode for both inputs are selected via inverter parameter Anlg In Cnfg (320). In this parameter, if the bit corresponding to a particular analog input is set (i.e. has a value of 1), then the analog input is in current-sensing mode; otherwise, it is in voltage-sensing mode.

The following table describes the correspondence between the mode of each user-configurable analog input and the combined I/O board terminals that should be used.

Input and Mode	Parameter 320 Setting	Combined I/O Board Designator
Analog input 1, voltage-sensing	Bot 0 = 0	AI1
Analog input 1, current-sensing	Bit 0 = 1	AI3
Analog input 2, voltage-sensing	Bit 1 = 0	AI2
Analog input 2, current-sensing	Bit 1 = 1	AI4

2.6.4 Analog Outputs

The combined I/O board contains one user-configurable analog output. The output is configurable using inverter parameters Anlg Out Config through Analog Out1 Lo (340-344). The analog output has two modes: voltage (output can output -10V to +10V) and current (output can output 0mA to 20mA). Separate terminals on the combined I/O board are used for each mode. The mode is selected via inverter parameter Anlg Out Config (340). In this parameter, if the lowest bit is set (i.e. has a value of 1), then the analog output is in voltage mode; otherwise it is in current mode.

The following table describes the correspondence between the mode of the user-configurable analog output and the combined I/O board terminals that should be used.

Mode	Parameter 340 Setting	Combined I/O Board Designator
Analog Output, voltage	Bot 0 = 0	AO3
Analog Output, current	Bit 0 = 1	AO4

The combined I/O board contains two special purpose analog outputs: AO1 and AO2. These outputs are not user-configurable.

2.7 DPI Communication Port

For frame 3 drives, the Communication Interface board contains three DIN connectors that can be used as DPI communication ports. See figure 2.11. These ports provide communication between the LiquiFlo 2.0 drive and other DPI devices (for example, an OIM or a personal computer running the VS Utilities software). The three connectors (DPI ports 3, 4, and 5) are equivalent. This manual will assume that peripherals are always plugged into DPI port 3.

For frame 4 drives, there is only one DPI port, accessible via the “OIM” connector on the front panel of the power module (see figure 2.12). An internal cable connects this connector to the DIN connector on the control board. A device plugged directly into this connector will use DPI port 3. If there is a requirement that multiple DPI peripheral devices be connected, a DPI port expander box can be used, but no device should be plugged into the “DPI Port 2” connector because the rectifier connects to the inverter using that port.

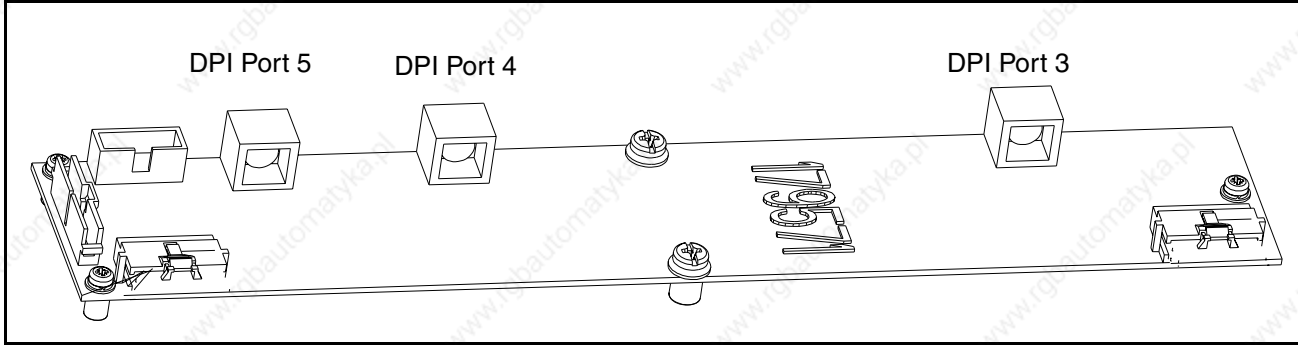

Figure 2.12 – DPI Communication Interface Board (Frame 3)

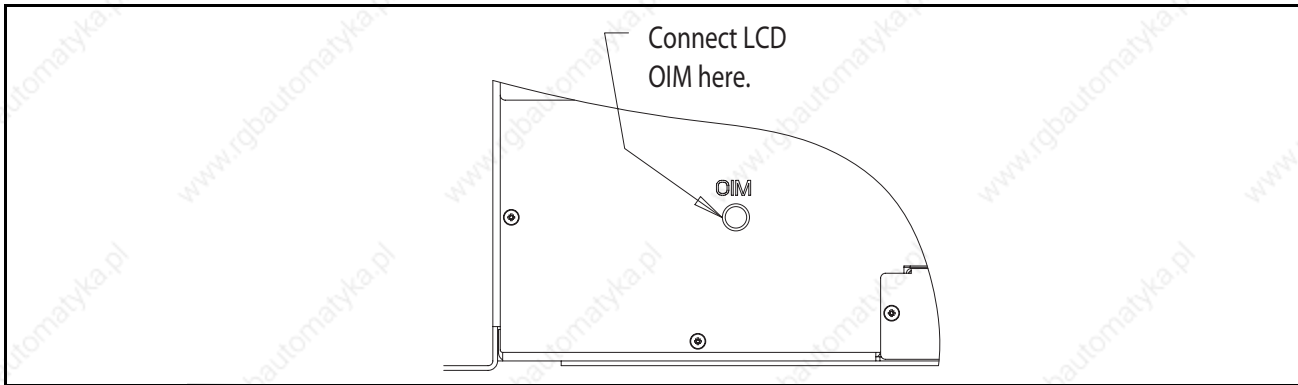

Figure 2.13 – Power Module Bottom Left Front View (Frame 4)

2.8 Optional Equipment

Table 2.2 lists standard LiquiFlo 2.0 kits and options.

Table 2.2 – Available Kits and Options

Description	Model Number	Instruction Manual
Operator Interface Module (OIM)	RE1LCD	D2-3518
OIM LCD Hand-Held Cable	RECBL-LCD	n/a
OIM Door-Mount Bezel Kit	REBZL-N1	D2-3517
Serial Converter with VS Utilities Software	RECOMM-232	D2-3488

Planning the Installation

This chapter provides how to plan a LiquiFlo 2.0 drive installation.



ATTENTION: Only qualified electrical personnel familiar with the construction and operation of this equipment and the hazards involved should install, adjust, operate, or service this equipment. Read and understand this manual and other applicable manuals in their entirety before proceeding. Failure to observe this precaution could result in severe bodily injury or loss of life.

ATTENTION: Use of power correction capacitors on the output of the drive can result in erratic operation of the motor, nuisance tripping, and/or permanent damage to the drive. Remove power correction capacitors before proceeding. Failure to observe this precaution could result in damage to, or destruction of, the equipment.

ATTENTION: The user is responsible for conforming with all applicable local, national, and international codes. Failure to observe this precaution could result in damage to, or destruction of, the equipment.

3.1 General Requirements for the Installation Site

It is important to properly plan before installing a LiquiFlo 2.0 drive to ensure that the drive's environment and operating conditions are satisfactory. Read the following recommendations before continuing with drive installation.

3.1.1 Making Sure Environmental Conditions are Met

Before deciding on an installation site, consider the following guidelines:

- Verify that NEMA 1 enclosure drives can be kept clean and dry.
- The area chosen should allow the space required for proper air flow as defined in section 3.1.3.
- Be sure that the NEMA 1 enclosure is installed away from oil, coolants, or other airborne contaminants.
- Do not install the drive above 1000 meters (3300 feet) without derating output power. For every 91.4 meters (300 feet) above 1000 meters (3300 feet), derate the output current 1%.
- Verify that the drive location will meet the environmental conditions specified in table 3.1.
- Floor-mounted units should be attached to the floor with the C-channel rails provided. See figure 2.2.

Table 3.1 – Environmental Conditions

Condition	Specification
Operating Temperature (inside NEMA 1 enclosure)	0°C to +55°C ¹ (32° to 131°F)
Ambient Temperature (outside NEMA 1 enclosure)	0°C to +40°C ¹ (32° to 104°F)
Storage Temperature (Ambient)	-40°C to 65°C (-40° to 149°F)
Humidity	5% to 95% (non-condensing)

¹With typical heat rise inside a cabinet, 40°C ambient outside usually results in 55°C inside.

3.1.2 Determining Total Area Required Based on Drive Dimensions

Overall drive dimensions for M/Ns 180264-Axx and 180264-Axx and for M/Ns 180180-A07 and 180180-A09 are illustrated in figures 3.1 and 3.3 as an aid in calculating the total area required by the LiquiFlo drives.

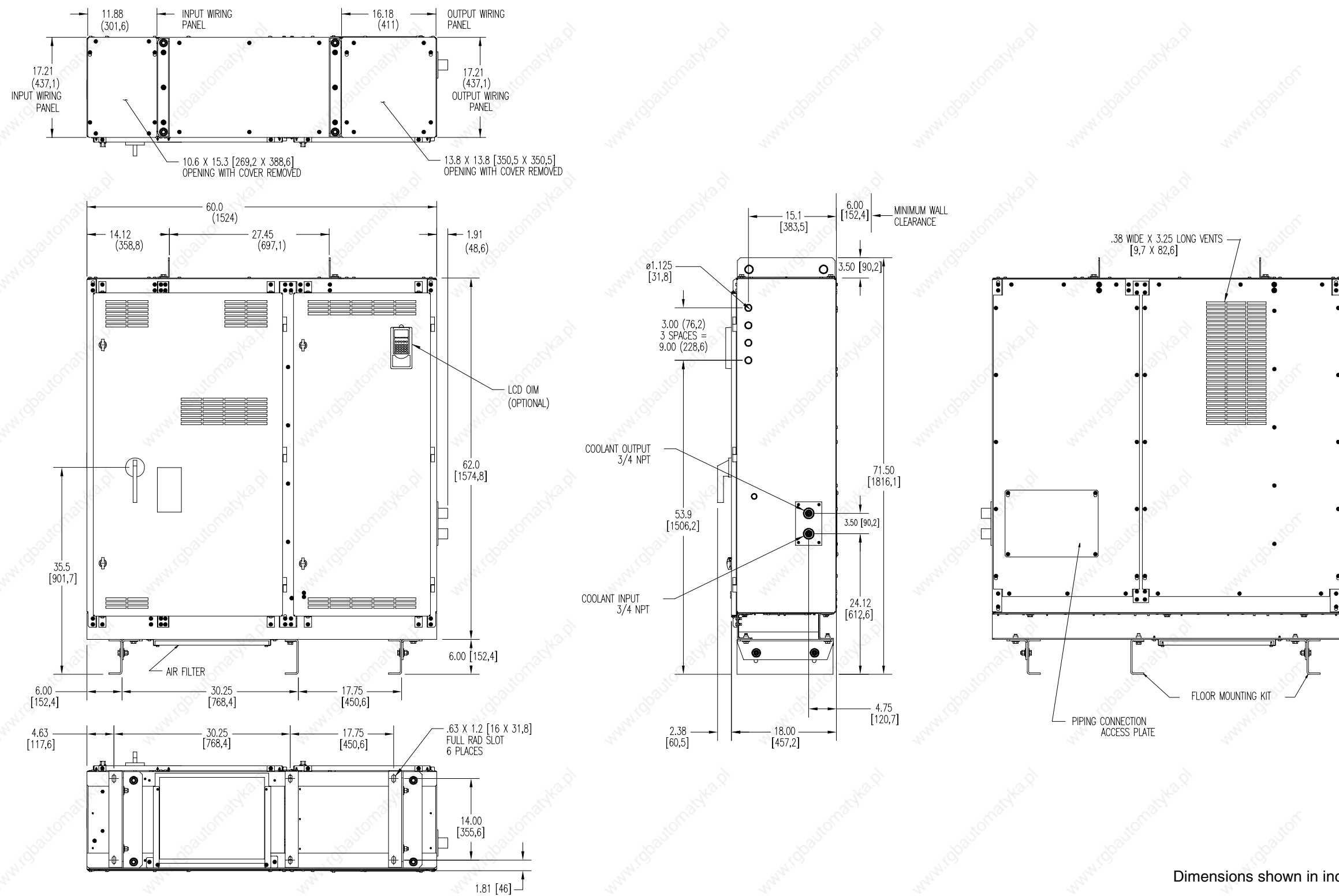

Dimensions shown in inches [mm]

Figure 3.1- Exterior Enclosure Dimensions - Frame 3A and 3B

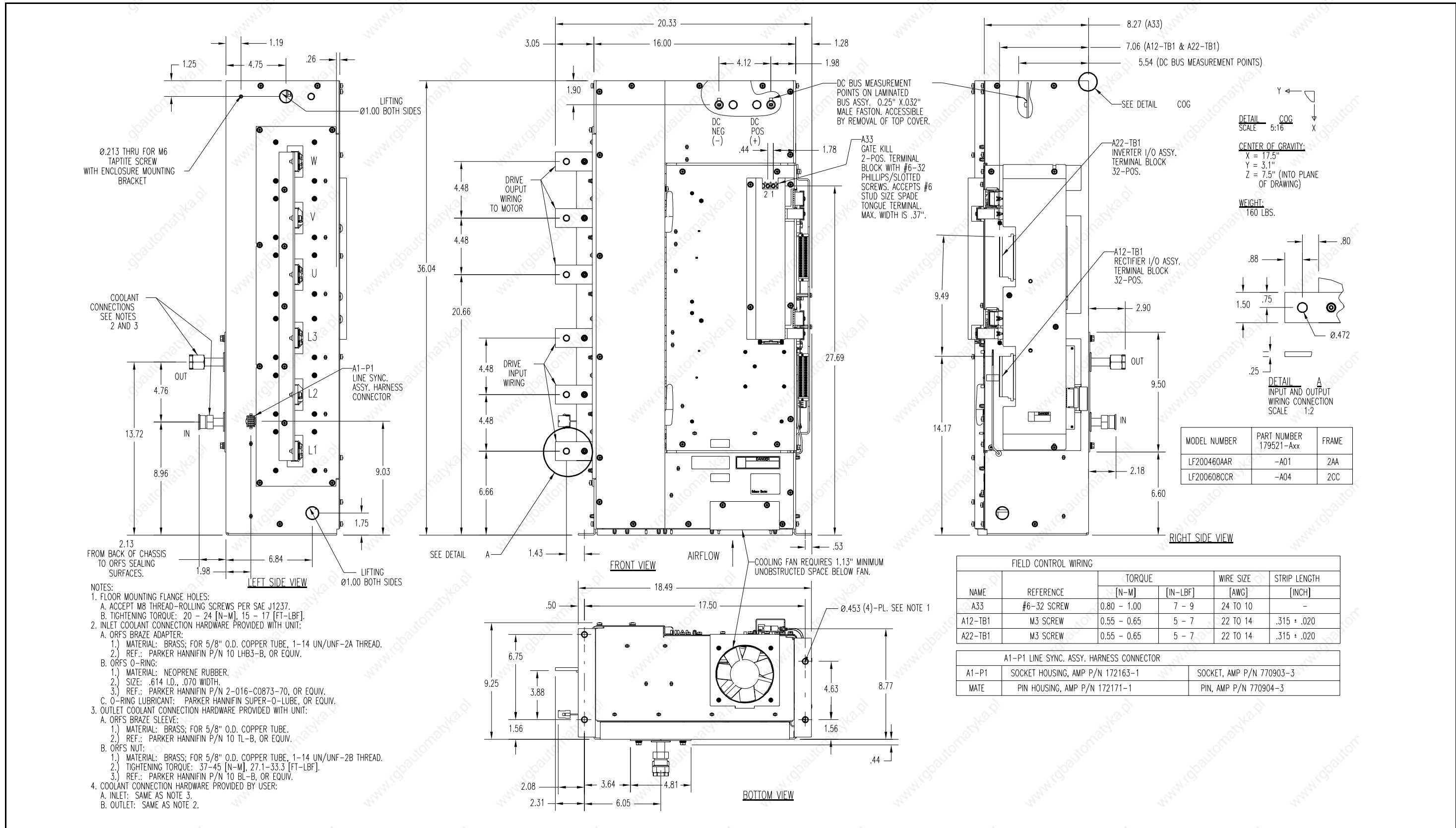
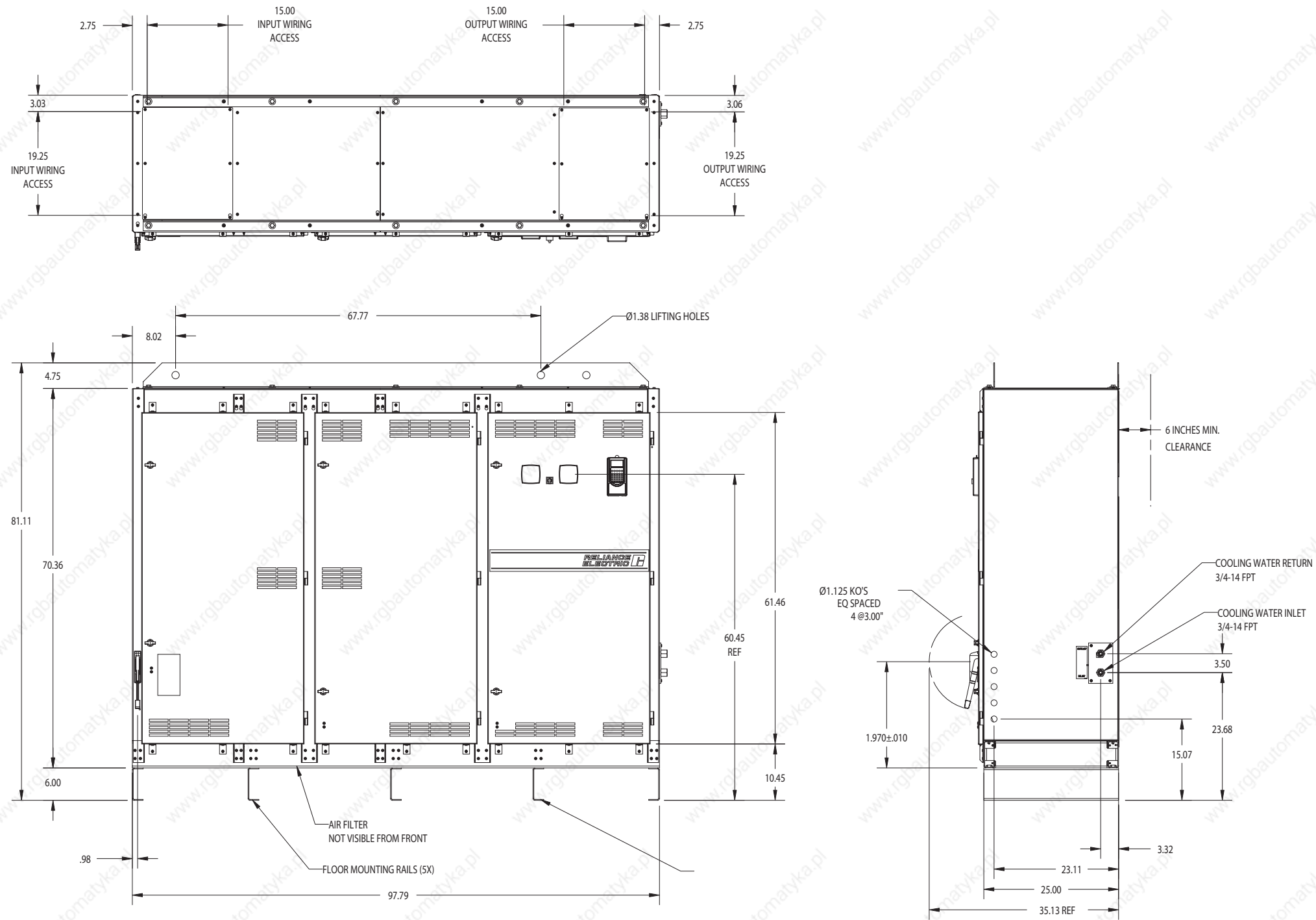

Figure 3.2- Power Module Dimensions - Frame 3



D2-3518-1 FIG 3.3 CABINET ASSEMBLY OUTLINE

Figure 3.3– Exterior Enclosure Dimensions -Frame 4

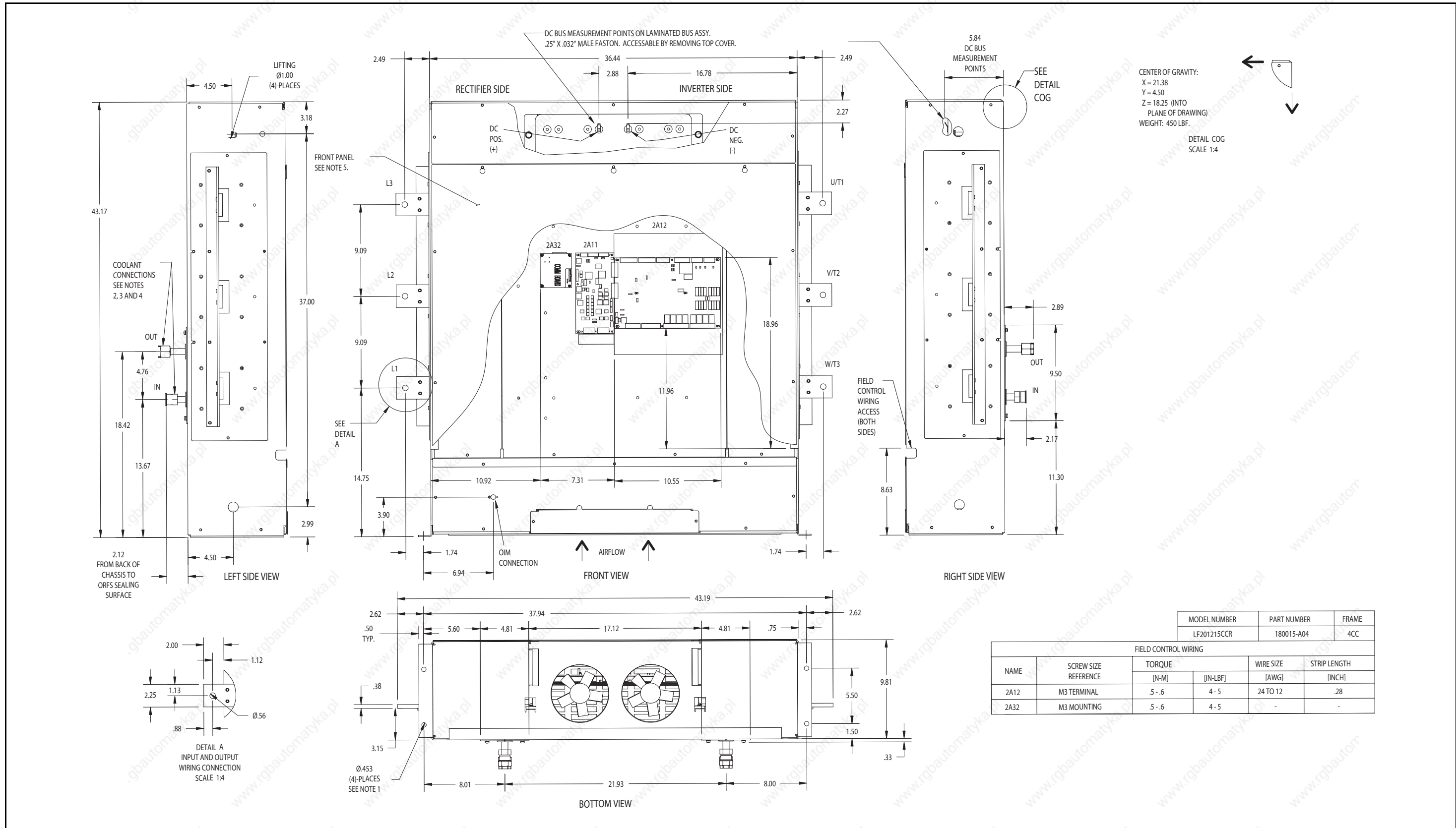

Figure 3.4— Power Module Dimensions - Frame 4

3.1.3 Verifying the Site Provides for Recommended Air Flow Clearances

Be sure there is adequate clearance for air circulation around the enclosure. A 6-inch minimum clearance is required wherever vents are located in the cabinet.

3.1.4 Verifying Power Module Input Ratings Match Supplied Power

It is important to verify that plant power will meet the input power requirements of the LiquiFlo drive's power module circuitry. Refer to table 2.1 for input power rating specifications. Be sure input power to the power module corresponds to the power module's nameplate voltage, current, and frequency.

3.2 Wiring Requirements for the Drive

Certain drive requirements should be checked before continuing with the drive installation. Input power wire sizes, branch circuit protection, and control wiring are all areas that need to be evaluated.

3.2.1 Determining Wire Size Requirements

Wire size should be determined based on the size of conduit openings, and applicable local, national, and international codes (e.g., NEC/CEC regulations).



ATTENTION: The user is responsible for conforming with all applicable local, national, and international codes. Failure to observe this precaution could result in damage to, or destruction of, the equipment.

3.2.1.1 Conduit Entry Opening Sizes

It is important to determine the size of the conduit openings in the cabinet that the drive is mounted in so that the wire planned for a specific entry point will fit through the opening.

3.2.1.2 Recommended Power Wire Sizes

Input power wiring should be copper and should be sized according to applicable codes to handle the drive's continuous-rated input current. Output wiring should be copper and should be sized according to applicable codes to handle the drive's continuous-rated output current.

3.2.1.3 Recommended Control and Signal Wire Sizes

The recommended wire size to connect I/O signals is 12 AWG maximum. Recommended terminal tightening torque is 7 to 9 in-lb.

3.2.1.4 Recommended Motor Lead Lengths

Motor lead lengths can total up to 76 meters (250 feet).

3.2.2 Verifying Power Module Output Current Rating Is Greater Than Motor Full Load Amps

Verify that the LiquiFlo power module output current rating is equal to or greater than the motor's full load current (amps). Table 2.1 lists the output current values.

3.3 Stopping the Drive



ATTENTION: The user must provide an external, hardwired emergency stop circuit outside of the drive circuitry. This circuit must disable the system in case of improper operation. Uncontrolled machine operation may result if this procedure is not followed. Failure to observe this precaution could result in bodily injury.

Depending upon the requirements of the application, the LiquiFlo drive can be programmed to provide either a coast-to-rest or a ramp-to-rest operational stop without physical separation of the power source from the motor.

A coast-to-rest stop turns off the gate drive to the IGBT power devices.

A ramp-to-rest stop continues to fire the IGBT power devices in a controlled manner until the motor comes to a stop, and then turns off the power devices.

The user can also program zero speed with power maintained to the motor, but in this condition, the drive is not actually stopped.

In addition to the operational stop, the LiquiFlo power module provides a hardwired "gate kill." This function provides a two-wire emergency stop circuit that does not depend on software or on the transmission of commands over a communications network. When the two-wire circuit is opened, the gate drive to the IGBTs is removed.

The gate kill function is provided by a two-position terminal block (A33) located on the power module as shown in figure 3.2. Remove the terminal block jumper to apply a normally closed emergency stop.

Mounting and Grounding the Drive

This chapter shows how to mount the drive and properly ground it.

4.1 Lifting and Mounting the Drive

Care should be used to prevent damage due to dropping or jolting when moving the drive. A fork lift truck or similar means of lifting and transporting may be used. Sling in a manner that will equalize the load at the pickup points. Use a spreader bar if the angle of the sling is less than 45 degrees relative to horizontal. Do not jolt while lifting.



ATTENTION: Do not use input and output busbars for lifting or handling. Failure to observe this precaution could result in damage to equipment.

ATTENTION: Mechanically support conductors to minimize mechanical load on input and output busbars. Failure to observe this precaution could result in damage to equipment.

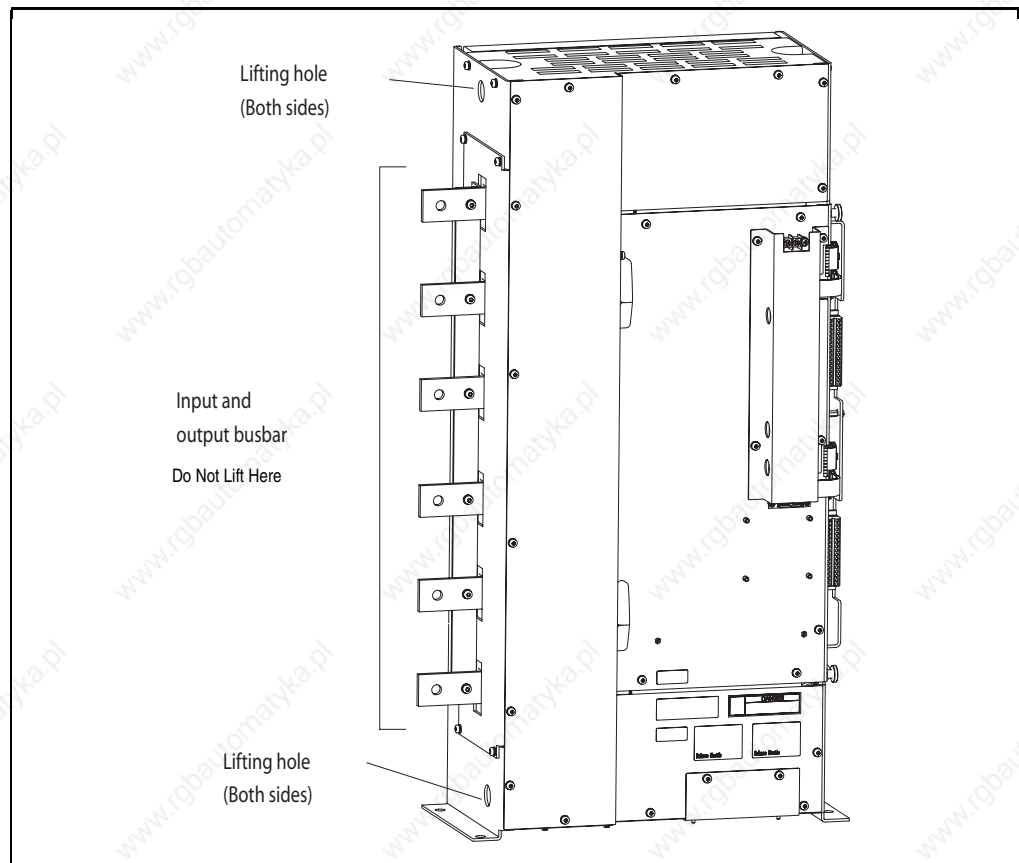

Figure 4.1 – Lift Point Locations for LiquiFlo 2.0 Drives (Frame 3)

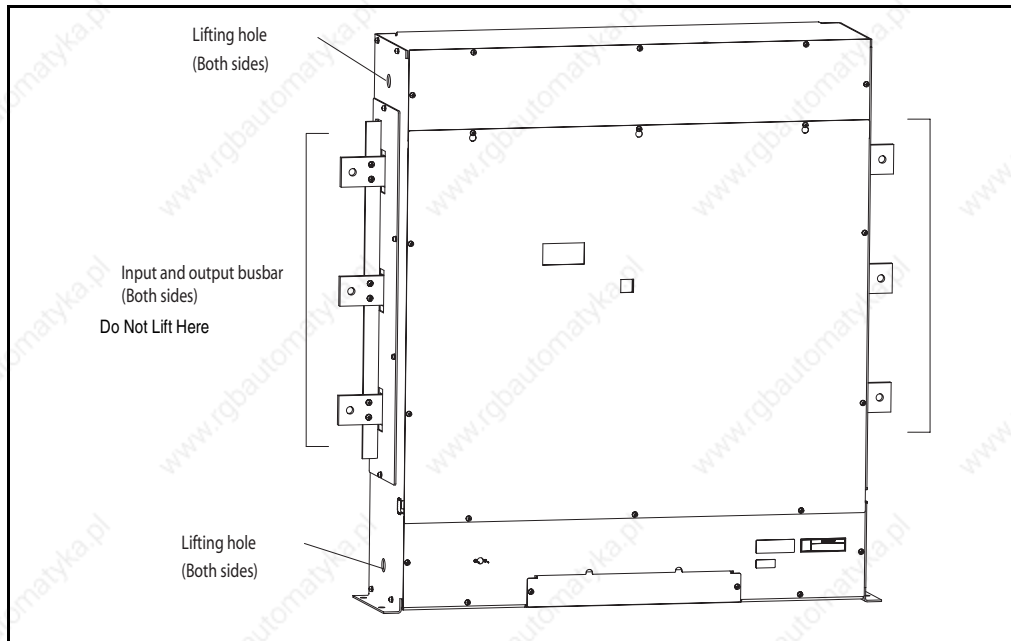

Figure 4.2 – Lift Point Locations for LiquiFlo 2.0 Drives (Frame 4)

Use the following procedure to lift and mount the LiquiFlo 2.0 drive:

- Step 1. Using an overhead or portable hoist (minimum 2 ton rated capacity), attach a free-fall chain to the chain secured to the drive. Take up any vertical slack in the chain.
- Step 2. Using the hoist, lift the drive from the horizontal shipping pallet.
- Step 3. Position the drive.
- Step 4. Machine fasten the drive enclosure using 1/2-inch bolts, grade 5 or better, with compression washers.

4.2 Grounding the Drive



ATTENTION: The user is responsible for conforming with all applicable local, national, and international codes. Failure to observe this precaution could result in damage to, or destruction of, the equipment.

Use the following steps to ground the drive:

- Step 1. Open the door of the enclosure.
- Step 2. Run a suitable equipment grounding conductor unbroken from the drive enclosure ground lug to earth ground. See figure 2.2. Tighten these grounding connections to the proper torque.
- Step 3. Close the door of the enclosure.

Installing Input and Output Power Wiring

All wiring should be installed in conformance with the applicable local, national, and international codes (e.g., NEC/CEC). Signal wiring, control wiring, and power wiring must be routed in separate conduits to prevent interference with drive operation. Use grommets, when hubs are not provided, to guard against wire chafing.

5.1 Installing Power Wiring from the AC Input Line to the Main Input Circuit Breaker

Use the following steps to connect AC input power to the main input circuit breaker:

- Step 1. Ensure primary power feed is turned off and locked out.
- Step 2. Remove the input wiring panel located on the top left of the drive. Move away from the drive and drill the required number of openings in the removed wiring panel. See figure 3.1.
- Step 3. Reinstall input wiring panel. Attach the conduit and pull the wire through.



ATTENTION: Do not route signal and control wiring with power wiring in the same conduit. This can cause interference with drive operation. Failure to observe this precaution could result in damage to, or destruction of, the equipment.

- Step 4. Connect the three-phase AC input power leads (three-wire 480 VAC) to the appropriate input terminals of the circuit breaker. See figure 2.2.
- Step 5. Tighten the AC input power terminals to the proper torque as specified on the input circuit breaker.

5.2 Installing Wiring from the Power Module Output Terminals to the Motor

Important: The total motor lead length must not exceed 76 meters (250 feet).

Refer to table 5.1 for recommended motor lead minimum wire sizes. Motor lead wiring should comply with all local and national codes.

Use the following steps to connect the AC output power wiring from the power module to the motor:

- Step 1. Ensure , lock out, and tag the input power to the drive. Wait five minutes.
- Step 2. Remove the input wiring panel. Move away from the drive and drill the required number of openings in the removed wiring panel. See figure 3.1.
- Step 3. Connect the three-phase AC output power motor leads to the power module bus bars labeled U, V, and W, as shown in figure 2.2.
- Step 4. Tighten the three-phase AC output power terminals (1/2-13, Gr. 5 fasteners to 100 N-m (75 ft-lb)).

Table 5.1 – Minimum Motor Lead Wire Size

Power Module Model Number	Minimum Motor Lead Wire Size
LF200460AAR	2 x 2/0 AWG
LF200460BAR	2 x 2/0 AWG
LF200520BBR	2 x 250 MCM
LF200608CCR	2 x 250 MCM
LF201215BBR	4 x 250 MCM

Completing the Installation

This chapter provides instructions on how to perform a final check of the installation before power is applied to the drive.



ATTENTION: Only qualified electrical personnel familiar with the construction and operation of this equipment and the hazards involved should start and adjust it. Read and understand this manual in its entirety before proceeding. Failure to observe this precaution could result in severe bodily injury or loss of life.

6.1 Checking the Installation

Use the following procedure to verify the condition of the installation.



ATTENTION: DC bus capacitors retain hazardous voltages after input power has been disconnected. After disconnecting input power, wait five (5) minutes for the DC bus capacitors to discharge and then check the voltage with a voltmeter to ensure the DC bus capacitors are discharged before touching any internal components. Failure to observe this precaution could result in severe bodily injury or loss of life.

- Step 1. Turn off, lock out, and tag the input power to the drive. Wait five minutes.
- Step 2. Verify that the DC bus voltage is zero. Refer to section 10.1.



ATTENTION: The user must provide an external, hardwired emergency stop circuit outside of the drive circuitry. This circuit must disable the system in case of improper operation. Uncontrolled machine operation may result if this procedure is not followed. Failure to observe this precaution could result in bodily injury.

- Step 3. Remove any debris, such as metal shavings, from around the drive.
- Step 4. Check that there is adequate clearance around the drive.
- Step 5. Verify that the wiring to the terminal strip and the power terminals is correct.
- Step 6. Check that the wire size is within terminal specifications and that the wires are tightened properly.
- Step 7. Check that user-supplied branch circuit protection is installed and correctly rated.
- Step 8. Check that the incoming power is rated correctly.
- Step 9. Check the motor installation and length of motor leads.

Step 10. Check that the rating of the transformer (if used) matches the drive requirements and is connected properly.

Step 11. Verify that a properly-sized ground wire is installed and a suitable earth ground is used. Check for and eliminate any grounds between the motor frame and the motor power leads. Verify that all ground leads are unbroken.

Step 12. Visually inspect the liquid-cooling connections for leaks.

6.2 Powering Up After Installation Is Complete

Use the following procedure to verify that the drive is installed correctly and is receiving the proper line voltage:

Step 1. Turn the drive's input circuit breaker to the On position.

Step 2. Ensure that coolant is flowing through the power module.

Step 3. Follow the start-up procedure in chapter 7.

Using the Start-Up Routines



ATTENTION: Only qualified electrical personnel familiar with the construction and operation of this equipment and the hazards involved should install, adjust, operate, or service this equipment. Read and understand this chapter in its entirety before proceeding. Failure to observe this precaution could result in severe bodily injury or loss of life.

ATTENTION: Incorrect values for some of the parameters in the Start-Up routines can cause the drive to operate improperly. Verify that the values of these parameters are appropriate for your application. Failure to observe this precaution could result in bodily injury.

For standard applications, the Start-Up routines on the LCD OIM enable you to configure the most commonly used parameters through a series of steps. This helps you set up the drive as quickly as possible.

For advanced applications, you may need to adjust additional parameters in the parameter list using either the LCD OIM or VS Utilities software.

7.1 Preparing for Start-Up

Before performing Start-Up, you must:

- be qualified to configure the drive and be familiar with the operation of AC drives.
- be familiar with the operation of the LCD OIM.
- have completed all hardware installation.
- properly connect the drive to the motor.

7.2 Running the Start-Up Routines

To access the Start-Up routines, select the Start-Up icon from the main menu as shown in figure 7.1.

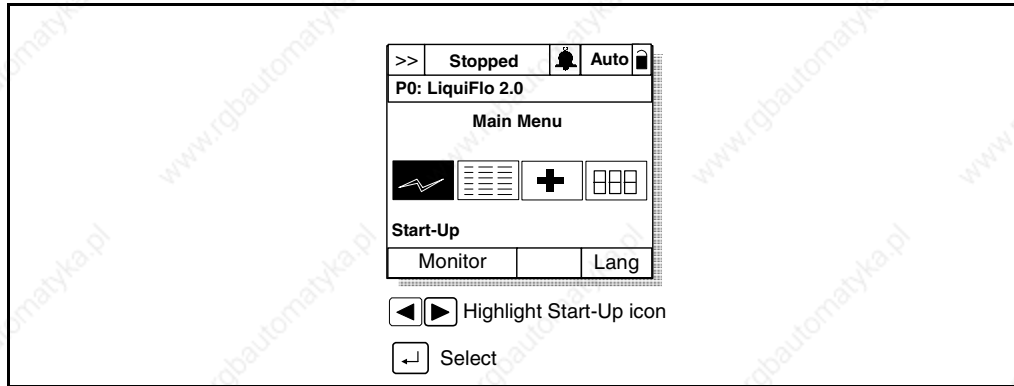

Figure 7.1 – Accessing the Start-Up Routines

The Start-Up menu screen contains 8 selections. The first 7 menu items contain the most commonly used parameters associated with each function. See figure 7.2.

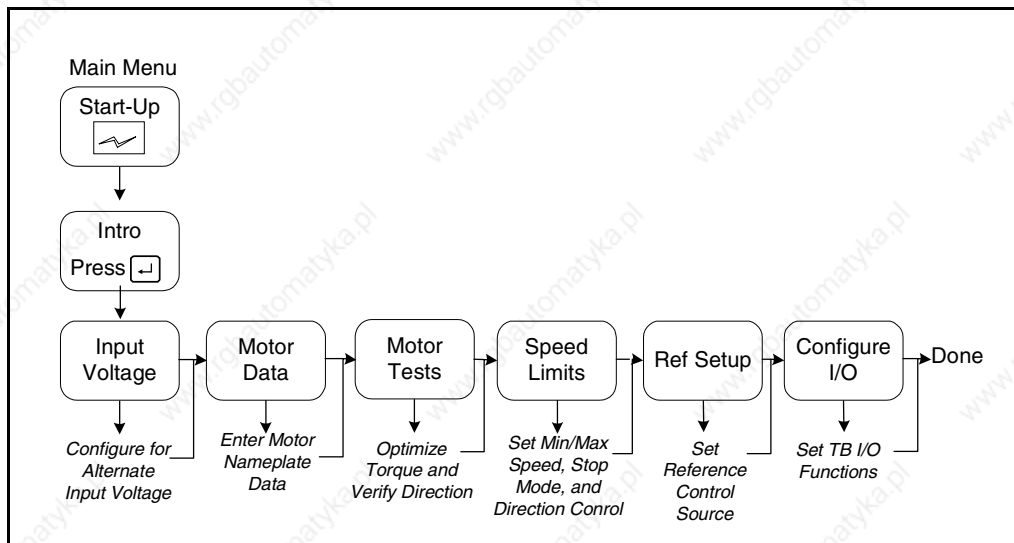



Figure 7.2 – Start-Up Menu

The Start-Up routine automates the process of entering values of selected parameters by taking you to the next parameter after you accept a parameter value. As each item in the list is completed, you are automatically advanced to the next step.

Important: Parameter values are saved as they are changed. Pressing  or aborting the Start-Up routine will not undo the changes.

Exiting Before Completing the Start-Up Routines

To exit the Start-Up routines, press the F4 key (Exit). When you select the Start-Up icon from the main menu again, you will be prompted to either continue or restart the Start-Up routines. If you select “continue,” you will be returned to the point at which you exited.

Programming Basics

To program the drive for a specific application, you adjust the appropriate parameters. The parameters are used to define characteristics of the drive.

This chapter provides an overview of parameter types and how they are organized. Parameter descriptions are provided in chapter 9.

8.1 About Parameters

There are three types of parameters:

- **Numbered List Parameters**

Numbered list parameters allow a selection from two or more options. The LCD OIM displays a text message for each item.

Example: Speed Ref A Sel (90)

- **Bit Parameters**

Bit parameters have individual bits associated with features or conditions. If the bit is 0, the feature is off or the condition is false. If the bit is 1, the feature is on or the condition is true.

Example: Drive Status 1 (209)

- **Numeric Parameters**

These parameters have a single numerical value (for example, 0.1 volts).

Example: Maximum Freq (55)

Parameters are also either configurable or tunable, or read-only.

Configurable parameters can be adjusted or changed only while the drive is stopped.

Tunable parameters can be adjusted or changed while the drive is running or stopped.

Read-only parameters cannot be adjusted.

8.2 How Parameters are Organized

Inverter parameters are organized into seven files:

- Monitor
- Motor Control
- Speed Command
- Dynamic Control
- Utility
- Communication
- Inputs & Outputs

Rectifier parameters are organized into seven files:

- Monitor
- Configuration
- Dynamic Control
- Internal Data
- Utility
- Communication
- Inputs and Outputs

Each file contains parameters that are grouped by their function. A file can contain several groups of parameters. See figure 8.1.

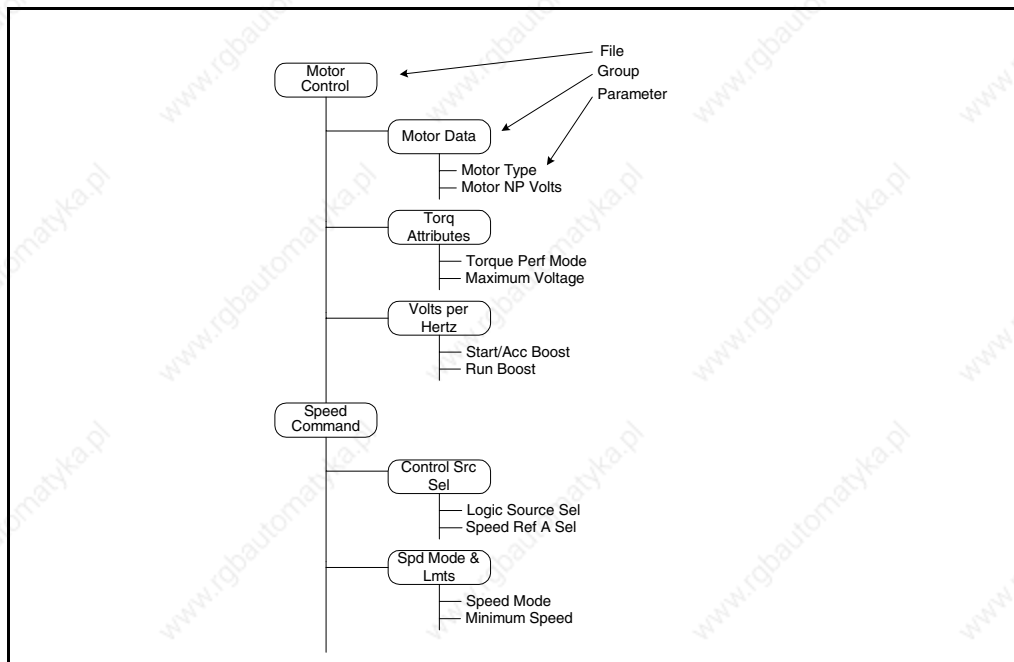

Figure 8.1 – Example of Parameter Organization

8.3 Accessing the Parameters

Parameters are programmed and viewed using the LCD OIM or VS Utilities software.

The LCD OIM displays parameters by group, by individual parameter number, and parameters that have changed from their default value.

To access parameters using the LCD OIM, select the Parameters icon from the main screen. See figure 8.2.

See chapter 2 for information on modifying parameters using the LCD OIM.

See instruction manual D2-3488 for information on accessing and modifying parameters using VS Utilities software.

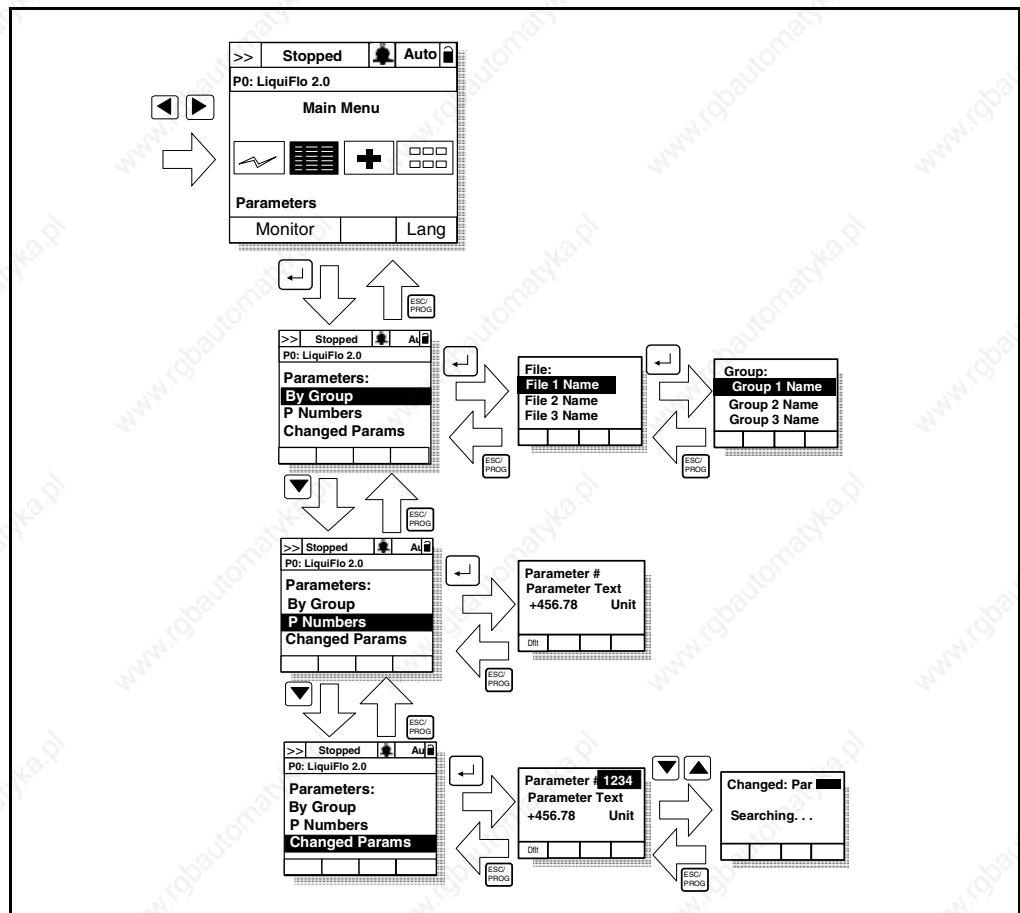

Figure 8.2 – Accessing the Parameters Using the LCD OIM

8.3.1 Viewing Rectifier Parameters

The LCD OIM initially displays information about the inverter, including inverter parameters.

To display rectifier parameters and other information about the rectifier, the LCD OIM must be switched to the Active Rectifier device. Refer to figure 8.3.

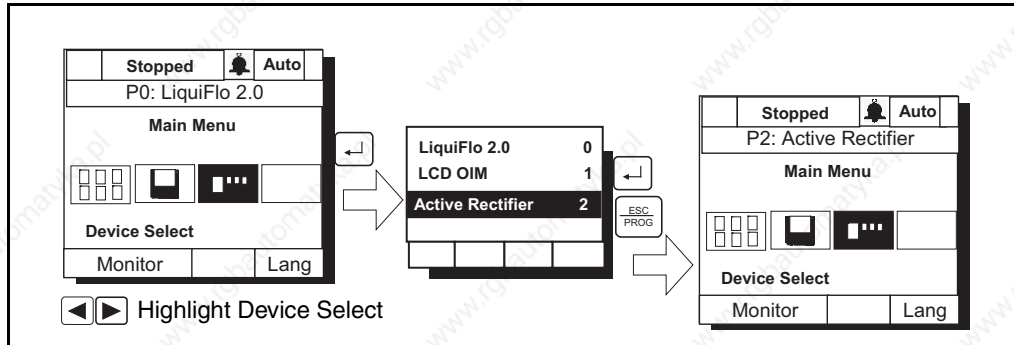

Figure 8.3 – Selecting the Active Rectifier

To switch back to viewing inverter information, use the process described by figure 8.3, but select the “LiquiFlo 2.0” device.

8.4 Selecting the Parameter Access Level

The LiquiFlo 2.0 AC drive provides two levels of access to the parameters: Basic (0) and Advanced (1).

The Advanced level allows access to all of the parameters.

The Basic level allows access to a subset of the Standard level and contains only the most commonly used parameters.

The active access level is displayed in Parameter Access Level (196).

To select the parameter access level using the LCD OIM, select the Password icon from the main menu. See figure 8.4.

This option is not supported in the VS Utilities software.

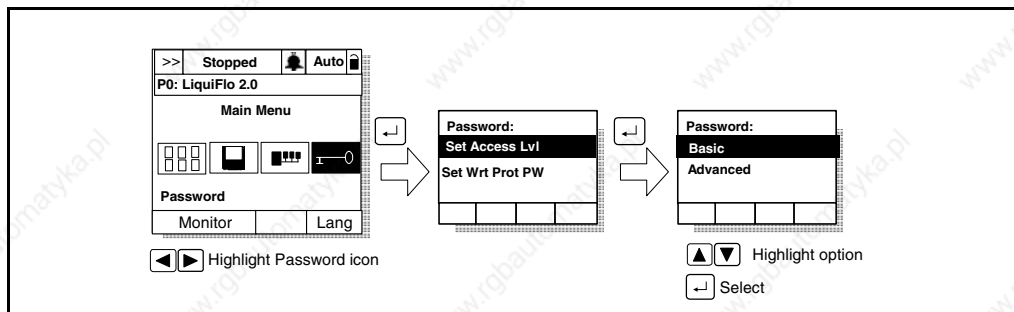

Figure 8.4 – Selecting the Parameter Access Level



8.5 Ensuring Program Security



ATTENTION: It is the user's responsibility to determine how to distribute the write-protect password. Reliance Electric is not responsible for unauthorized access violations within the user's organization. Failure to observe this precaution could result in bodily injury.

Parameter values can be password-protected using the LCD OIM. When the password is enabled, parameter values can be displayed. However, if there is an attempt to change a parameter value, a password pop-up box will appear on the OIM screen to prompt for the user-defined password.

To set the write-protect password, select the Password icon from the main menu. See figure 8.5. The password value can range from 1 to 9999. A value of 0 disables the password (factory default). To disable the password, you must first enter the correct value and then set the password to zero.

When the password is enabled, the lock symbol on the screen changes from  to .

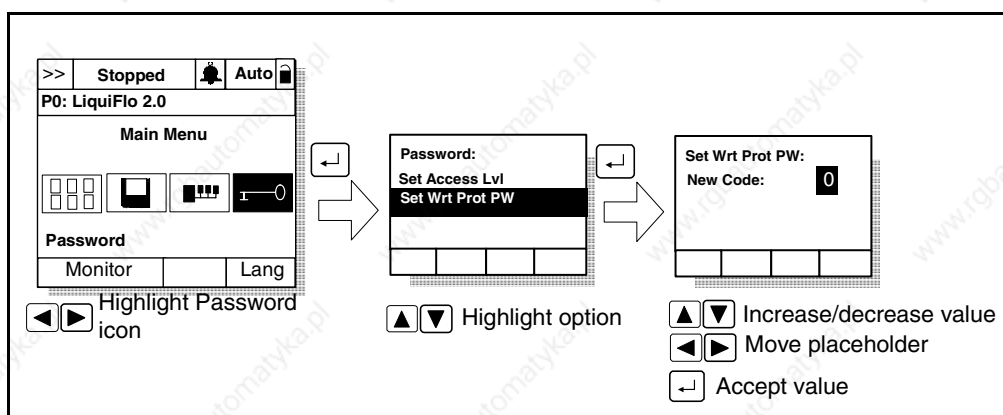

Figure 8.5 – Setting the Write-Protect Password

When you enter the password, you can adjust parameters until you select Logout or return to the process display screen, which re-activates the password. Refer to Appendix B, section B.7, in for information about the process display screen.

This option is not supported in the VS Utilities software.

If There is More Than One OIM Connected to the Drive

Important: Setting the write-protect password value to zero on one OIM will disable the write-protect password on all connected OIMs.

Setting the write-protect password in one OIM will not affect any other OIM connected to the drive unless a write-protect password has also been set in the other OIMs. In this case, the last password value entered becomes the password value for all password-protected OIMs. (Each OIM cannot have a different password value.)

For example, if the write-protect password has been set to 5555 for the local OIM, someone using a remote OIM with no write-protect password set can still program all of the parameters. If the write-protect password is then set to 6666 on the remote OIM, you will be required to enter 6666 on the local OIM to program the parameters.

www.rgbautomatyka.pl



CHAPTER 9

Parameter Descriptions

The following information is provided for each parameter along with its description:

- Parameter Number:** Unique number assigned to each parameter.
- Parameter Name:** Unique name assigned to each parameter.
- Range:** Predefined parameter limits or selections. Note that a negative Hz value indicates reverse rotation.
- Default:** Factory default setting.
- Access:** Parameter access level.
0 = Basic (reduced parameter set)
1 = Advanced (full parameter set)
- Path:** Menu selections to reach specified parameter. The path is indicated in this manner: File>Group
- See also:** Associated parameters that may provide additional or related information.

What the Symbols Mean

Symbol	Meaning
	32-bit parameter
	Drive must be stopped before changing parameter value.

The parameters are presented in numerical order.

9.1 Inverter Parameters

1 Output Freq

Range: +/-400.0 Hz [0.1 Hz]
Default: Read Only
Access: 0 **Path:** Monitor>Metering
See also:

The output frequency present at T1, T2, and T3 (U, V, and W).

2 Commanded Freq

Range: +/- 400.0 Hz [0.1 Hz]
Default: Read Only
Access: 0 **Path:** Monitor>Metering
See also:

The value of the active frequency command.

3 Output Current

Range: 0.0 to 3276.7 A [0.1 A]
Default: Read Only
Access: 0 **Path:** Monitor>Metering
See also:

The total output current present at T1, T2, and T3 (U, V, and W).

4 Torque Current

Range: +/- 819.2 A [0.1 A]
Default: Read Only
Access: 1 **Path:** Monitor>Metering
See also:

The amount of current that is in phase with the fundamental voltage component.

5 Flux Current

Range: +/- 819.2 A [0.1 A]
Default: Read Only
Access: 1 **Path:** Monitor>Metering
See also:

The amount of current that is out of phase with the fundamental voltage component.

6 Output Voltage

Range: 0.0 to 600.0 VAC [0.1 VAC]
Default: Read Only
Access: 1 **Path:** Monitor>Metering
See also:

The output voltage present at terminals T1, T2, and T3 (U, V, and W).

7 Output Power

Range: 0 to 2400.0 kW [0.1 kW]
Default: Read Only
Access: 1 **Path:** Monitor>Metering
See also:

The output power present at T1, T2, and T3 (U, V, and W).

8 Output Power Fctr

Range: 0.00 to 1.00 [0.01]
Default: Read Only
Access: 1 **Path:** Monitor>Metering
See also:

The output power factor.

9 Elapsed MWh



Range: 0.0 to 429,496,729.5 MWh [0.1 MWh]
Default: Read Only
Access: 1 **Path:** Monitor>Metering
See also:

The accumulated output energy of the drive.

10 Elapsed Run Time



Range: 0.0 to 429,496,729.5 Hr [0.1 Hr]
Default: Read Only
Access: 1 **Path:** Monitor>Metering
See also:

The accumulated time the drive has been outputting power.

11 MOP Frequency

Range: +/- 400.0 [0.1 Hz]
Default: Read Only
Access: 1 **Path:** Monitor>Metering
See also:

The value of the signal at the MOP (Motor-Operated Potentiometer).

12 DC Bus Voltage

Range: 0 to 3276.7 VDC [0.1 VDC]
Default: Read Only
Access: 0 **Path:** Monitor>Metering
See also:

The present DC bus voltage level.

13 DC Bus Memory

Range: 0 to 819.2 VDC [0.1 VDC]
Default: Read Only
Access: 1 **Path:** Monitor>Metering
See also:

A six-minute average of the DC bus voltage level.

16 Analog In1 Value

17 Analog In2 Value

18 Analog In3 Value

Range: 0.000 to 20.000 mA [0.001 mA]
-/+10.000 V [0.001 V]
Default: Read Only
Access: 1 **Path:** Monitor>Metering
See also:

The value of the signal of the analog input.

Analog In3 Value (18) is not usable with LiquiFlo 2.0 drives, and is only provided for compatibility with other drive models.

21 Ground Current

Range: 0.0 to 3276.7 [0.1 A]
Default: Read Only
Access: 1 **Path:** Monitor>Metering
See also:

The analog value of motor ground current. Ground current trip is at about 7% of drive rated current.

22 Phase U Current

23 Phase V Current

24 Phase W Current

Range: 0.0 to 3276.7 [0.1 A]
Default: Read Only
Access: 1 **Path:** Monitor>Metering
See also:

The RMS motor current value, as follows:

- Parameter 22 displays the phase U current value.
- Parameter 23 displays the phase V current value.
- Parameter 24 displays the phase W current value.

25 Est Input Power

Range: 0.0 to 3000.0 [0.1 kW]
Default: Read Only
Access: 1 **Path:** Monitor>Metering
See also: 7

The estimated input power of the drive. This value is calculated as a function of the output power.

26 Rated kW



Range: 0.00 to 3000.00 kW [0.01 kW]
Default: Read Only
Access: 1 **Path:** Monitor>Drive Data
See also:

The drive power rating.

27 Rated Volts

Range: 208 to 600 V [0.1 VAC]
Default: Read Only
Access: 1 **Path:** Monitor>Drive Data
See also:

The drive input voltage class (208, 240, 400, etc.).

28 Rated Amps

Range: 0.0 to 6553.5 Amps [0.1 Amps]
Default: Read Only
Access: 1 **Path:** Monitor>Drive Data
See also:

The drive rated output current.

29 Control SW Ver

Range: 0.000 to 65.256 [0.001]
Default: Read Only
Access: 1 **Path:** Monitor>Drive Data
See also: 196

The Main Control board software version.

30 Appl Digital Output

Range: See figure 9.1
Default: See figure 9.1
Access: 1 **Path:** Monitor>Application
See also: 32

Frame 3 drives (firmware version 1.x) only:

31 Appl Analog Output

Range: -32.767 to 32.767
Default: See table 9.1 below.
Access: 1 **Path:** Monitor>Application
See also: 342, 343, 344

The value entered into this parameter is output to the user-configurable analog output when it is configured for “Application” control. See parameter Analog Out1 Sel (342).

The usable range and default for this parameter depends on the operational mode of the analog output, which in turn depends both on the capabilities of the analog output hardware and the current value of parameter Analog Out Config (340). Table 9.1 describes the details for usable range and default.

Table 9.1 – Appl Analog Output (31) usable range and default

Mode	Usable Range	Default
0 V to 10 V (unipolar)	0.000 V to 10.000 V	0.000 V
-10 V to +10 V (bipolar)	-10.000 V to 10.000 V	0.000 V
4mA to 20mA	0.000 mA to 20.000 mA	0.000 mA

The value in the “Default” column of table 9.1 will be in effect when the drive powers up. This parameter value is not stored in non-volatile memory.

For frame 3 drives (firmware version 1.x), the user-configurable analog output hardware is located on the Standard I/O Board. See section 2.5 for terminal block assignments.

For frame 4 drives (firmware version 2.x), the user-configurable analog output hardware is located on the Combined I/O Board. See section 2.6 for terminal block assignments.

32 Rctfr Config

Range: 0 = Run at Start
1 = Run at Power Up
2 = Manual Control
3 = Diode Rectifier
Default: 3
Access: 1 **Path:** Monitor>Application
See also: 30

Selects how sequencing will operate.

0 = Run at Start: The precharge is closed and voltage regulation is enabled when the inverter is requested to start.

1 = Run at Power Up: The precharge is closed and voltage regulation is enabled when power is turned on.

2 = Manual Control: The closing of the precharge and enabling of voltage regulation is controlled by some other device writing into the application digital output word.

3 = Diode Rectifier: Rectifier consists of a diode bridge.

33 Rctfr Control

Range: See figure 9.3
Default: Read Only
Access: 1 **Path:** Monitor>Application
See also: 30, 32

Frame 3 drives (firmware version 1.x) only:

The commanded state of the rectifier.

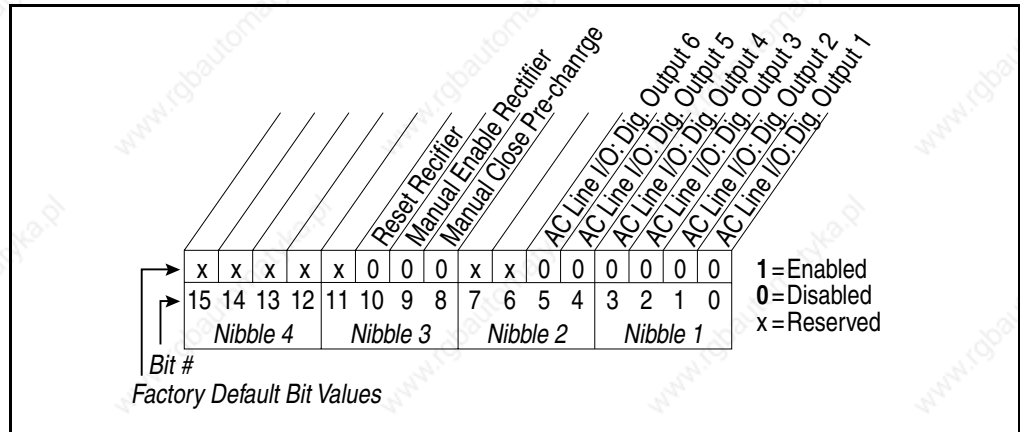

Figure 9.3 – Rectifier Control (33)

Frame 4 drives (firmware version 2.x) only:

The commanded state of the rectifier.

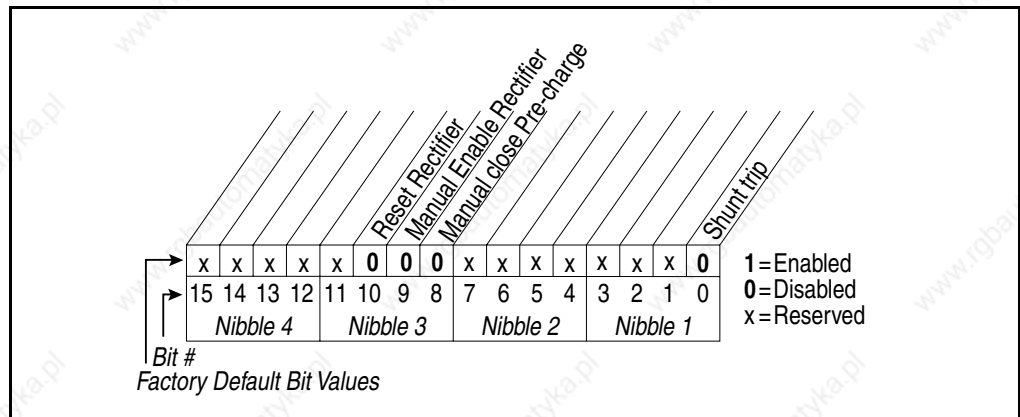

Figure 9.4 – Rectifier Control (33) Frame 4

34 Rctfr Status

Range: See figure 9.5
Default: Read Only
Access: 1 **Path:** Monitor>Application
See also:

The actual state of the rectifier.

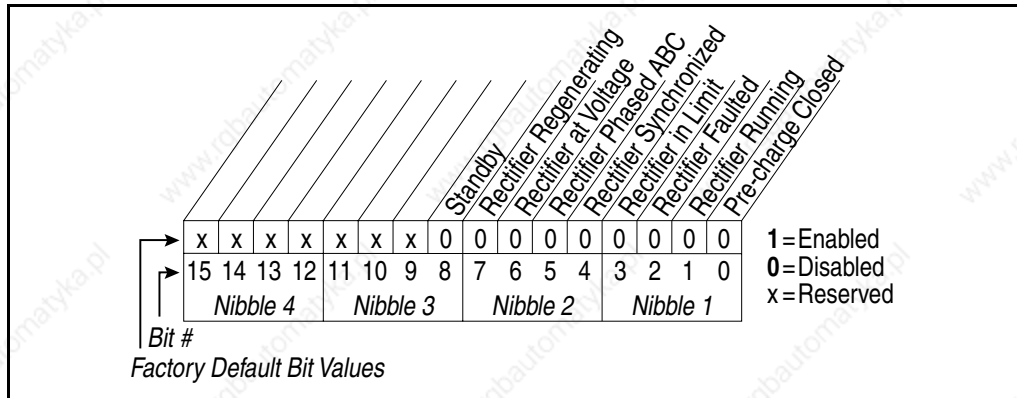

Figure 9.5 – Rectifier Status (34)

35 Rctfr Fault

Range: 0 to 299
Default: Read Only
Access: 1 **Path:** Monitor>Application
See also:

Displays a fault from the rectifier. The rectifier writes a fault code into this parameter through a data link.

Rctfr Fault is used for internal communication between the rectifier and the inverter, and the drive operator does not normally need to refer to this parameter when troubleshooting fault conditions. See chapter 10 for information on troubleshooting.

40 Motor Type



Range: 0 = Induction
1 = Synchr Reluc
2 = Synchr PM
Default: 0 = Induction
Access: 1 **Path:** Motor Control>Motor Data
See also:

Set to match the type of motor connected: Induction, Synchronous Reluctance, or Synchronous Permanent Magnet.

41 Motor NP Volts



Range: 0.0 to Drive Rated Volts [0.1 VAC]
Default: Based on Drive Type
Access: 0 **Path:** Motor Control>Motor Data
See also:

Set to the motor nameplate rated volts. The motor nameplate base voltage defines the output voltage when operating at rated current, rated speed, and rated temperature.

42 Motor NP FLA



Range: 0.0 to Rated Amps x 2 [0.1 Amps]
Default: Based on Drive Type
Access: 0 **Path:** Motor Control>Motor Data
See also: 47, 48

Set to the motor nameplate rated full load amps. The motor nameplate FLA defines the output amps when operating at rated voltage, rated speed, and rated temperature. It is used in the motor thermal overload and in the calculation of slip.

43 Motor NP Hertz



Range: 5.0 to 250.0 Hz [0.1 Hz]
Default: Based on Drive Type
Access: 0 **Path:** Motor Control>Motor Data
See also:

Set to the motor nameplate rated frequency. The motor nameplate base frequency defines the output frequency when operating at rated voltage, rated current, rated speed, and rated temperature.

44 Motor NP RPM



Range: 60 to 24000 RPM [1 RPM]
Default: 1780 RPM
Access: 0 **Path:** Motor Control>Motor Data
See also:

Set to the motor nameplate rated RPM. The motor nameplate RPM defines the rated speed when operating at motor nameplate base frequency, rated current, base voltage, and rated temperature. This is used to calculate slip.

45 Motor NP Power



Range: 0.00 to 3000.00 [0.01 kW or 0.01 HP]
Default: Based on Drive Type
Access: 0 **Path:** Motor Control>Motor Data
See also: 46

Set to the motor nameplate rated power. The motor nameplate power is used with the other nameplate values to calculate default values for motor parameters to assist the commissioning process. This may be entered in horsepower or in kilowatts as selected in parameter 46.

46 Mtr NP Pwr Units



Range: 0 = Horsepower
1 = kilowatts
Default: Based on Drive Type
Access: 0 **Path:** Motor Control>Motor Data
See also:

Set to the power units shown on the motor nameplate. This parameter determines the units for parameter 45.

47 Motor OL Hertz

<input type="checkbox"/>	Range:	0.0 to 400.0 Hz [0.1 Hz]
	Default:	0
	Access:	0 Path: Motor Control>Motor Data
	See also:	42, 48, 220

Selects the output frequency below which the motor operating current is derated. The motor thermal overload will then generate a fault at lower levels of current. For all settings of overload Hz other than zero, the overload capacity is reduced to 70% when output frequency is zero.

48 Motor OL Amps

<input type="checkbox"/>	Range:	1.0 to 2000.0 [0.1 A]
	Default:	Based on Drive Type
	Access:	1 Path: Motor Control>Motor Data
	See also:	42, 47, 220

Sets the amps threshold for fault. In order for the motor overload fault (48) to occur, it must be enabled using inverter parameter Fault Config 1 (238).

The motor overload fault will occur if the drive output (motor) current is 138% of Motor OL Amps for 1.5 seconds. The drive output current is visible in inverter parameter Output Current (3). If the drive output current is greater than 138% of Motor OL Amps, the fault will occur in less than 1.5 seconds.

If the drive output current is between 102% and 138% of Motor OL Amps, the fault will occur in greater than 1.5 seconds.

If the drive output current is less than 102% of Motor OL Amps, the fault will not occur.

Motor overload fault percent trip is visible in inverter parameter Motor OL Count (220). The fault occurs when this parameter reaches 100%. This parameter does not increase unless the drive output current is greater than 102% of Motor OL Amps.

49 Imbalance Limit

	Range:	0.0 to 40.0 [0.1%]
	Default:	10.0
	Access:	1 Path: Motor Control>Motor Data
	See also:	50, 221

Sets the fault threshold for motor current imbalance.

50 Imbalance Time

	Range:	1.0 to 10.0 [0.1 sec]
	Default:	5.0
	Access:	1 Path: Motor Control>Motor Data
	See also:	49, 221

Sets the time delay in generating a motor current imbalance fault.

53 Torque Perf Mode



Range: 0 = Sensrls Vect
1 = SV Economize
2 = Custom V/Hz
3 = Fan/Pmp-V/Hz

Default: 0 = Sensrls Vect

Access: 0 **Path:** Motor Control>Torq Attributes

See also: 62, 63, 69, 70

Sets the method of motor torque production.

54 Maximum Voltage

Range: (Rated Volts x 0.25) to Rated Volts [0.1 VAC]

Default: Drive Rated Volts

Access: 0 **Path:** Motor Control>Torq Attributes

See also:

Sets the highest voltage the drive will output.

55 Maximum Freq



Range: 5.0 to 250.0 Hz [0.1 Hz]

Default: 130.0 Hz

Access: 0 **Path:** Motor Control>Torq Attributes

See also: 82, 83

Sets the maximum allowable frequency the drive will output. Note that this is not maximum speed, which is set in parameter 82. Refer to figure 9.6.

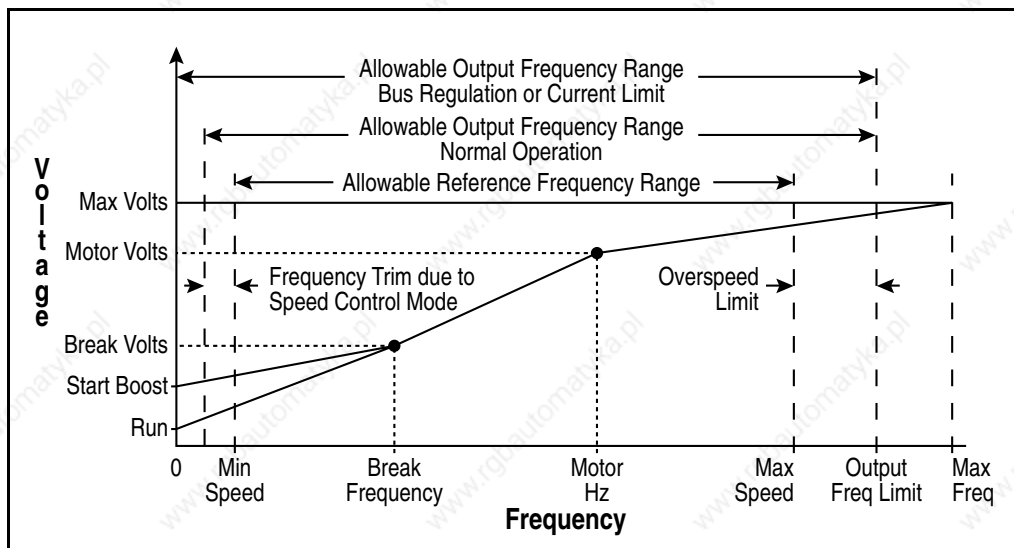

Figure 9.6 – Speed Limits

56 Compensation

Range: See figure 9.7
Default: See figure 9.7
Access: 1 **Path:** Motor Control>Torq Attributes
See also:

Enables/disables the compensation correction options.

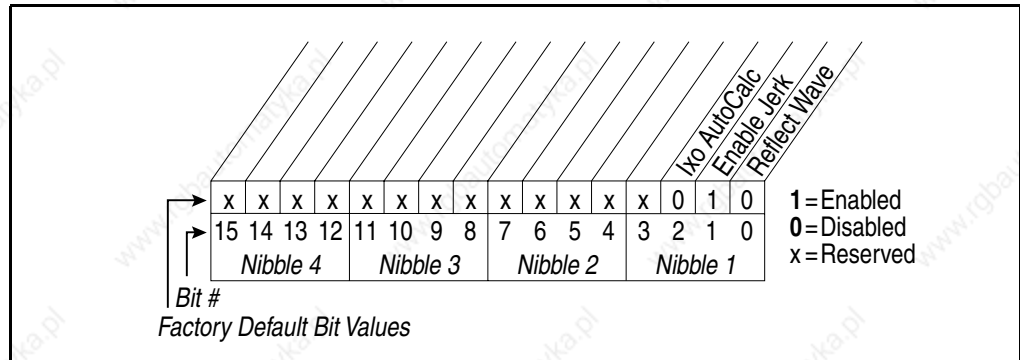

Figure 9.7 – Compensation (56)

Bit 0 - Reflect Wave

- Enables/disables reflected wave correction software, which reduces overvoltage transients from the drive to the motor. For lead lengths beyond 300 feet, enable this feature.

Bit 1 - Enable Jerk

- Enables/disables the jerk limit in the current limiter that helps to eliminate overcurrent trips on fast accelerations. Disable this feature if your application requires the actual acceleration of the motor to be faster than .25 sec.

57 Flux Up Mode

Range: 0 = Manual
1 = Automatic
Default: 0 = Manual
Access: 1 **Path:** Motor Control>Torq Attributes
See also: 53, 58

0 = Manual: Flux is established for Flux Up Time (58) before acceleration

1 = Auto: Flux is established for a calculated time period based on motor nameplate data. Flux Up Time (58) is not used.

58 Flux Up Time

Range: 0.00 to 5.00 sec [0.01 sec]
Default: 0.0 sec
Access: 1 **Path:** Motor Control>Torq Attributes
See also: 53, 58

Sets the amount of time the drive will use to try to achieve full motor stator flux. When a start command is issued, DC current at current limit level is used to build stator flux before accelerating.

59 SV Boost Filter

Range: 0 to 32767
Default: 500
Access: 1 **Path:** Motor Control>Torq Attributes
See also:

Sets the amount of filtering used to boost voltage during Sensorless Vector operation.

61 Autotune



Range: 0 = Ready
1 = Static Tune
2 = Rotate Tune
3 = Calculate
Default: 3 = Calculate
Access: 0 **Path:** Motor Control>Torq Attributes
See also: 53, 62, 63

Provides a manual or automatic method for setting IR Voltage Drop (62) and Flux Current Ref (63), which affect sensorless vector performance. Valid only when Torque Perf Mode (53) is set to Sensrls Vect or SV Economize.

0 = Ready: Parameter returns to this setting following a Static Tune or Rotate Tune. It also permits manually setting IR Voltage Drop (62) and Flux Current Ref (63).

1 = Static Tune: A temporary command that initiates a non-rotational motor stator resistance test for the best possible automatic setting of IR Voltage Drop. A start command is required following the initiation of this setting. The parameter returns to 0 = Ready following the test, at which time another start transition is required to operate the drive in normal mode. Used when the motor cannot be uncoupled from the load.

2 = Rotate Tune: A temporary command that initiates a Static Tune followed by a rotational test for the best possible automatic setting of Flux Current Ref. A start command is required following initiation of this setting. The parameter returns to 0 = Ready following the test, at which time another start transition is required to operate the drive in normal mode.



ATTENTION: Rotation of the motor in an undesired direction can occur during this procedure (Autotune (61) is set to 2 = Rotate Tune). To guard against possible injury and/or equipment damage, it is recommended that the motor be disconnected from the load before proceeding.

Important: Rotate Tune is used when motor is uncoupled from the load. Results may not be valid if a load is coupled to the motor during this procedure.

3 = Calculate (3): This setting uses motor nameplate data to automatically set IR Voltage Drop and Flux Current Ref.

62 IR Voltage Drop

Range: 0.0 to Motor NP Volts x 0.25 [0.1 VAC]
Default: Based on Drive Rating
Access: 1 **Path:** Motor Control>Torq Attributes
See also: 53

Value of volts dropped across the resistance of the motor stator. Used only when Torque Perf Mode (53) is set to Sensrls Vect or SV Economize.

63 Flux Current Ref



Range: 0.00 to Drive Rated Amps [0.01 Amps]
Default: Based on Drive Rating
Access: 1 **Path:** Motor Control>Torq Attributes
See also: 53

Value of amps for full motor flux. Used only when Torque Perf Mode (53) is set to Sensrls Vect or SV Economize.

64 Ixo Voltage Drop



Range: 0.00 to 230.0 or 460.0 V [0.1 VAC]
Default: Based on Drive Rating
Access: 1 **Path:** Motor Control>Torq Attributes
See also:

Sets the value of the voltage drop due to leakage inductance of the motor. Used only when Torque Perf Mode (53) is set to Sensrls Vect or SV Economize.

69 Start/Acc Boost

Range: 0.0 to Motor NP Volts x 0.25 [0.1 VAC]
Default: Based on drive rating
Access: 1 **Path:** Motor Control>Volts per Hertz
See also: 53, 70, 83

Sets the voltage boost level for starting and acceleration when Custom V/Hz mode is selected in Torque Perf Mode (53).

70 Run Boost

Range: 0.0 to Motor NP Volts x 0.25 [0.1 VAC]
Default: Based on drive rating
Access: 1 **Path:** Motor Control>Volts per Hertz
See also: 53, 69, 83

Sets the boost level for steady state or deceleration when Fan/Pmp V/Hz or Custom V/Hz modes are selected in Torque Perf Mode (53).

71 Break Voltage

Range: 0.0 to Motor NP Volts [0.1 VAC]
Default: Motor NP Volts x 0.25
Access: 1 **Path:** Motor Control>Volts per Hertz
See also: 53, 72, 83

Sets the voltage the drive will output at Break Frequency (72).

72 Break Frequency

Range: 0.0 to 250.0 [0.1 Hz]
Default: Motor NP Freq x 0.25
Access: 1 **Path:** Motor Control>Volts per Hertz
See also: 53, 71, 83

Sets the frequency the drive will output at Break Voltage (71).

80 Speed Mode



Range: 0 = Open Loop
1 = Slip Comp
2 = Process PI
Default: 0 = Open Loop
Access: 1 **Path:** Speed Command>Spd Mode & Limits
See also: 124 -138

Sets the method of speed regulation.

81 Minimum Speed



Range: 0.0 to Maximum Speed [0.1 Hz]

Default: 0.0 Hz

Access: 0 **Path:** Speed Command>Spd Mode & Limits

See also: 83, 92, 95

Sets the low limit for the speed reference after scaling is applied.



ATTENTION: The drive can operate at and maintain zero speed. The user is responsible for assuring safe conditions for operating personnel by providing suitable guards, audible or visual alarms, or other devices to indicate that the drive is operating or may operate at or near zero speed. Failure to observe this precaution could result in severe bodily injury or loss of life.

82 Maximum Speed



Range: 5.0 to 400.0 [0.1 Hz]

Default: 60.0 Hz

Access: 0 **Path:** Speed Command>Spd Mode & Limits

See also: 55, 83, 91, 94, 202

Sets the high limit for the speed reference after scaling is applied.



ATTENTION: The user is responsible for ensuring that driven machinery, all drive-train mechanisms, and application material are capable of safe operation at the maximum operating speed of the drive. Overspeed detection in the drive determines when the drive shuts down. See figure 9.8. Failure to observe this precaution could result in bodily injury.

83 Overspeed Limit



Range: 0.0 to 20.0 Hz [0.1 Hz]
Default: 10.0 Hz
Access: 1 **Path:** Speed Command>Spd Mode & Limits
See also: 55, 82

Sets the incremental amount of the output frequency (above Maximum Speed) allowable for functions such as slip compensation. See figure 9.8

Maximum Speed + Overspeed Limit must be \leq to Maximum Frequency

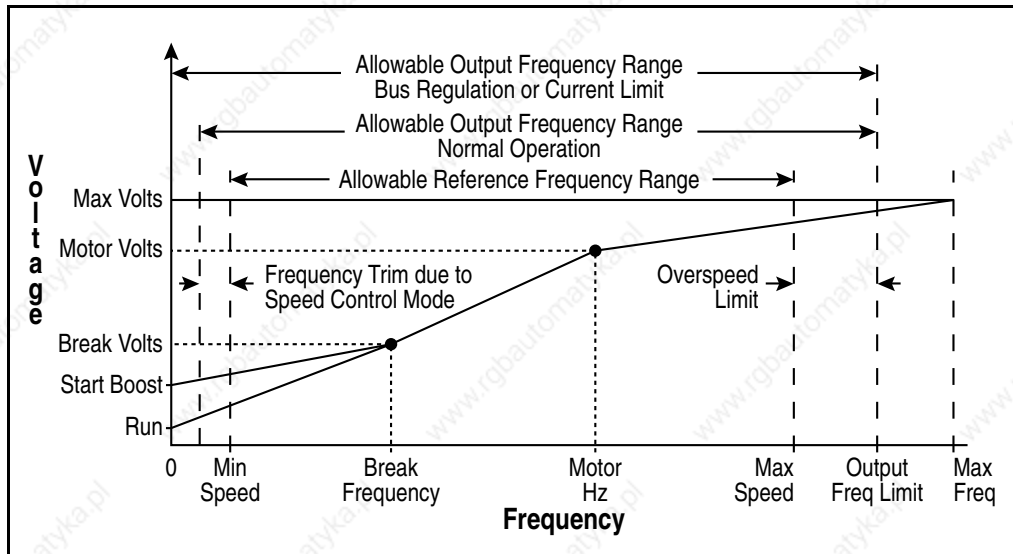

Figure 9.8 – Speed Limits

84 Skip Frequency 1

85 Skip Frequency 2

86 Skip Frequency 3

Range: -/+250.0 [0.1 Hz]
Default: 0.0 Hz
Access: 1 **Path:** Speed Command>Spd Mode & Limits
See also: 87

Sets a frequency at which the drive will not operate (also called an **avoidance frequency**). Requires that both Skip Frequency 1-3 and Skip Frequency Band (87) be set to a value other than 0.

87 Skip Freq Band

Range: 0.0 to 30.0 Hz [0.1 Hz]
Default: 0.0 Hz
Access: 1 **Path:** Speed Command>Spd Mode & Limits
See also: 84, 85, 86

Determines the bandwidth around a skip frequency (half the band above and half the band below the skip frequency).

90 Speed Ref A Sel



Range: 1 = Analog In 1
2 = Analog In 2
3-8 = Reserved
9 = MOP Level
10 = Reserved
11 = Preset Spd 1
12 = Preset Spd 2
13 = Preset Spd 3
14 = Preset Spd 4
15 = Preset Spd 5
16 = Preset Spd 6
17 = Preset Spd 7
18 = Network
19 = DPI Port 2
20 = DPI Port 3
21 = DPI Port 4
22 = DPI Port 5
Default: 17 = Preset Spd 7
Access: 0 **Path:** Speed Command>Speed References
See also: 2, 91-93, 101-107, 117-120, 192-194, 213, 272, 273, 361-366

Selects the source of the speed reference to the drive unless Preset Speed 1-7 (101-107) is selected.

Note that the manual reference command and input OIM Control can override the reference control source.



ATTENTION: Removing and replacing the LCD OIM while the drive is running may cause an abrupt speed change if the LCD OIM is the selected reference source. The drive will ramp to the reference level provided by the OIM at the rate specified in Accel Time 1 (140), Accel Time 2 (141), Decel Time 1 (142) and Decel Time 2 (143). Be aware that an abrupt speed change may occur depending upon the new reference level and the rate specified in these parameters. Failure to observe this precaution could result in bodily injury.

91 Speed Ref A Hi

Range: -/+Maximum Speed [0.1 Hz]
Default: Maximum Speed
Access: 0 **Path:** Speed Command>Speed References
See also: 82

Scales the upper value of the Speed Ref A Sel (90) selection when the source is an analog input.

92 Speed Ref A Lo

Range: -/+Maximum Speed [0.1 Hz]
Default: 0.0 Hz
Access: 0 **Path:** Speed Command>Speed References
See also: 81

Scales the lower value of the Speed Ref A Sel (90) selection when the source is an analog input.

93 Speed Ref B Sel



Range: 1 = Analog In 1
2 = Analog In 2
3-8 = Reserved
9 = MOP Level
10 = Reserved
11 = Preset Spd 1
12 = Preset Spd 2
13 = Preset Spd 3
14 = Preset Spd 4
15 = Preset Spd 5
16 = Preset Spd 6
17 = Preset Spd 7
18 = Network
19 = DPI Port 2
20 = DPI Port 3
21 = DPI Port 4
22 = DPI Port 5
Default: 17 = Preset Spd 7
Access: 0 **Path:** Speed Command>Speed References
See also: 2, 91-93, 101-107, 117-120, 192-194, 213, 272, 273, 361-366

Selects the source of the speed reference to the drive unless Preset Speed 1-7 (101-107) is selected.

Note that the manual reference command and input OIM Control can override the reference control source.



ATTENTION: Removing and replacing the LCD OIM while the drive is running may cause an abrupt speed change if the LCD OIM is the selected reference source. The drive will ramp to the reference level provided by the OIM at the rate specified in Accel Time 1 (140), Accel Time 2 (141), Decel Time 1 (142) and Decel Time 2 (143). Be aware that an abrupt speed change may occur depending upon the new reference level and the rate specified in these parameters. Failure to observe this precaution could result in bodily injury.

94 Speed Ref B Hi

Range: -/+Maximum Speed [0.1 Hz]
Default: Maximum Speed
Access: 0 **Path:** Speed Command>Speed References
See also: 82

Scales the upper value of the Speed Ref B Sel (93) selection when the source is an analog input.

95 Speed Ref B Lo

Range: -/+Maximum Speed [0.1 Hz]
Default: 0.0 Hz
Access: 0 **Path:** Speed Command>Speed References
See also: 81

Scales the lower value of the Speed Ref B Sel (93) selection when the source is an analog input.

96 TB Man Ref Sel

Range: 1 = Analog In 1
2 = Analog In 2
3-8 = Reserved
9 = MOP Level
Default: 2 = Analog In 1
Access: 0 **Path:** Speed Command>Speed References
See also: 97, 98

Specifies the manual speed reference source when a digital input is configured for auto/manual and manual reference mode is active.

97 TB Man Ref Hi

Range: -/+Maximum Speed [0.1 Hz]

Default: Maximum Speed

Access: 0 **Path:** Speed Command>Speed References

See also: 96

Scales the upper value of the TB Man Ref Sel selection when the source is an analog input.

98 TB Man Ref Lo

Range: -/+Maximum Speed [0.1 Hz]

Default: 0.0 Hz

Access: 0 **Path:** Speed Command>Speed References

See also: 96

Scales the lower value of the TB Man Ref Sel selection when the source is an analog input.

100 Jog Speed

Range: 0 to Maximum Speed [0.1 Hz]

Default: 10.0 Hz

Access: 0 **Path:** Speed Command>Discrete Speeds

See also:

Sets the output frequency when a jog command is issued.

- 101 Preset Speed 1**
- 102 Preset Speed 2**
- 103 Preset Speed 3**
- 104 Preset Speed 4**
- 105 Preset Speed 5**
- 106 Preset Speed 6**
- 107 Preset Speed 7**

Range: -/+Maximum Speed [0.1 Hz]
Default: See table 9.2
Access: 101-107 = 0 **Path:** Speed Command>Discrete Speeds
See also: 90, 93

Provides an internal fixed speed command value when Speed Ref A = Preset Spd 1-7.

Table 9.2 – Default Values for Preset Speeds 1-7

Parameter No.	Parameter Name	Default
101	Preset Speed 1	5.0 Hz
102	Preset Speed 2	10.0 Hz
103	Preset Speed 3	20.0 Hz
104	Preset Speed 4	30.0 Hz
105	Preset Speed 5	40.0 Hz
106	Preset Speed 6	50.0 Hz
107	Preset Speed 7	60.0 Hz

117 Trim In Select



Range: 1 = Analog In 1
 2 = Analog In 2
 3-8 = Reserved
 9 = MOP Level
 10 = Reserved
 11 = Preset Spd 1
 12 = Preset Spd 2
 13 = Preset Spd 3
 14 = Preset Spd 4
 15 = Preset Spd 5
 16 = Preset Spd 6
 17 = Preset Spd 7
 18 = Network
 19 = DPI Port 2
 20 = DPI Port 3
 21 = DPI Port 4
 22 = DPI Port 5
Default: 2 = Analog In 2
Access: 1 **Path:** Speed Command>Speed Trim
See also: 90, 93

Specifies which input signal is being used as a trim input.

118 Trim Out Select



Range: See figure 9.9
Default: See figure 9.9
Access: 1 **Path:** Speed Command>Speed Trim
See also: 117, 119, 120

Specifies if Ref A speed reference is to be trimmed.

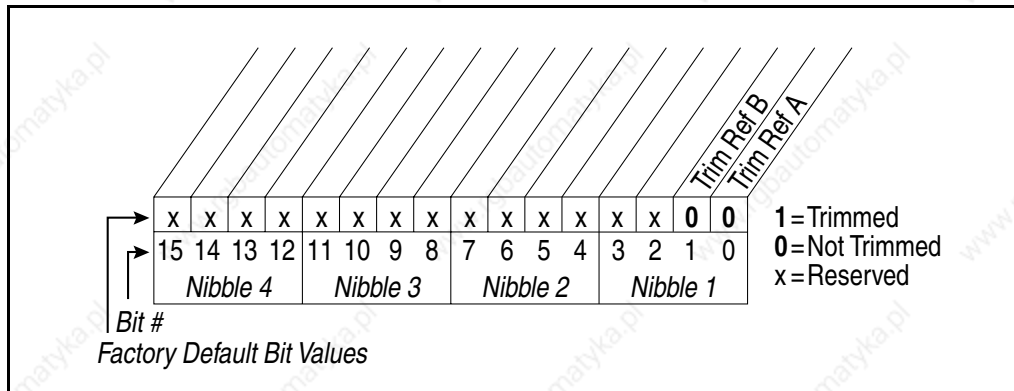

Figure 9.9 – Trim Out Select (118)

119 Trim Hi

Range: -/+Maximum Speed [0.1 Hz]
Default: 60.0 Hz
Access: 1 **Path:** Speed Command>Speed Trim
See also: 82, 117

Scales the upper value of the Trim In Select (117) selection when the source is an analog input.

120 Trim Lo

Range: -/+Maximum Speed [0.1 Hz]
Default: 0.0 Hz
Access: 1 **Path:** Speed Command>Speed Trim
See also: 117

Scales the lower value of the Trim In Select (117) selection when the source is an analog input.

Important: Parameters in the Slip Comp Group (121-123) are used to enable and tune the slip compensation regulator. To allow the slip compensation regulator to control drive operation, Speed Mode (80) must be set to 1=Slip Comp.

121 Slip RPM @ FLA

Range: 0.0 to 1200.0 RPM
Default: Based on Motor NP RPM
Access: 1 **Path:** Speed Command>Slip Comp
See also: 61, 80, 122, 123

Sets the amount of compensation to drive output at motor FLA. If parameter 61 (Autotune) = 3 Calculate, changes made to this parameter will not be accepted.

122 Slip Comp Gain

Range: 1.0 to 100.0 [0.1]
Default: 40.0
Access: 1 **Path:** Speed Command>Slip Comp
See also: 80, 121, 122

Sets the response time of slip compensation.

123 Slip RPM Meter

Range: -/+300.0 RPM
Default: Read Only
Access: 1 **Path:** Speed Command>Slip Comp
See also: 80, 121, 122

Displays the present amount of adjustment being applied as slip compensation.

124 PI Configuration



Range: See figure 9.10
Default: See figure 9.10
Access: 1 **Path:** Speed Command>Process PI
See also: 125-138

Selects specific features of the PI regulator.

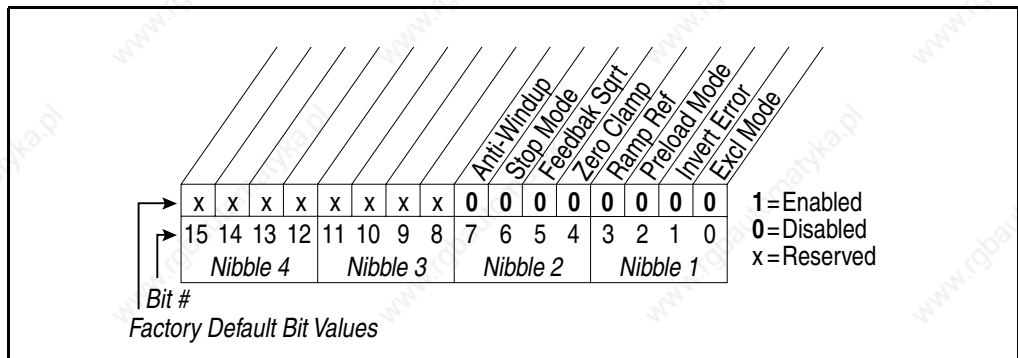

Figure 9.10 – PI Configuration (124)

Bit 0 - Excl Mode (Exclusive Mode)

- Enabled = Selects speed regulation.
- Disabled = Selects trim regulation.

Bit 1 - Invert Error

- Enables/disables the option to invert the sign of the PI error signal. Enabling this feature creates a decrease in output for an increasing error and an increase in output for a decreasing error.

Bit 2 - Preload Mode

- Enabled = Initializes the PI integrator to the commanded speed while the PI is disabled.
- Disabled = The PI integrator is loaded with the PI Pre-load (133) while the PI is disabled.

Bit 3 - Ramp Ref

- Enables/disables ramping the reference used from PI Feedback to the selected PI Reference.

Bit 4 - Zero Clamp

- Enables/disables option to limit operation so that the output frequency always has the same sign as the master speed reference. This limits the possible drive action to one direction only. Output from the drive will be from zero to maximum frequency forward or zero to maximum frequency reverse.

Bit 5 - Feedback Sqrt (Square Root Feedback)

- Enables/disables the option of using the square root of the feedback signal as the PI feedback.

Bit 6 - Stop Mode

Bit 7 - Anti-Windup

125 PI Control

Range:	See figure 9.11
Default:	See figure 9.11
Access:	1 Path: Speed Command>Process PI
See also:	124-138

Controls the PI regulator. Note that you must use a datalink to write to this parameter interactively from a network.

PI control allows the drive to take a reference signal (setpoint) and an actual signal (feedback) and automatically adjust the speed of the drive to match the actual signal to the reference.

Proportional control (P) adjusts the output based on the size of the error (larger error = proportionally larger correction).

Integral control (I) adjusts the output based on the duration of the error. The integral control by itself is a ramp output correction. This type of control gives a smoothing effect to the output and will continue to integrate until zero error is achieved.

By itself, integral control is slower than many applications require, and, therefore, is combined with proportional control (PI).

The purpose of the PI regulator is to regulate a process variable such as position, pressure, temperature, or flow rate, by controlling speed.

There are two ways the PI regulator can be configured to operate (see parameter 124):

- Process trim, which takes the output of the PI regulator and sums it with a master speed reference to control the process.
- Process control, which takes the output of the PI regulator as the speed command. No master speed reference exists, and the PI output directly controls the drive output.

Note that Speed Mode (80) must be set to 2 = Process PI.

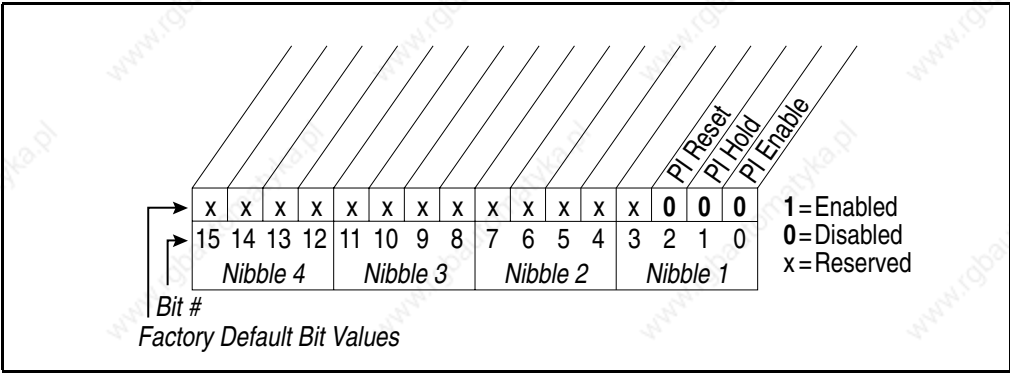

Figure 9.11 – PI Control (125)

Bit 0 - PI Enable

- Enables/disables the operation of the PI loop.

Bit 1 - PI Hold

- Enabled = The integrator for the outer control loop is held at the current level; that is, it will not increase.
- Enabled = The integrator for the outer PI control loop is allowed to increase.

Bit 2 - PI Reset

- Enabled = The integrator for the outer PI control loop is reset to zero.
- Disabled = The integrator for the outer PI control loop integrates normally.

126 PI Reference Sel



Range: 0 = PI Setpoint
1 = Analog In 1
2 = Analog In 2
3-8 = Reserved
9 = MOP Level
10 = Master Ref
11 = Preset Spd 1
12 = Preset Spd 2
13 = Preset Spd 3
14 = Preset Spd 4
15 = Preset Spd 5
16 = Preset Spd 6
17 = Preset Spd 7
18 = Network
19 = DPI Port 2
20 = DPI Port 3
21 = DPI Port 4
22 = DPI Port 5
23 = Reserved

Default: 0 = PI Setpoint

Access: 1 **Path:** Speed Command>Process PI

See also: 124-138

Selects the source of the PI reference signal.

127 PI Setpoint

Range: -/+100.00% of Maximum Process Value [0.01%]

Default: 50.00%

Access: 1 **Path:** Speed Command>Process PI

See also: 124-138

Provides an internal fixed value for the process setpoint when PI Reference Sel (126) is set to PI Setpoint.

128 PI Feedback Sel



Range: 0 = PI Setpoint
1 = Analog In 1
2 = Analog In 2
3-8 = Reserved
9 = MOP Level
10 = Master Ref
11 = Preset Spd 1
12 = Preset Spd 2
13 = Preset Spd 3
14 = Preset Spd 4
15 = Preset Spd 5
16 = Preset Spd 6
17 = Preset Spd 7
18 = Network
19 = DPI Port 2
20 = DPI Port 3
21 = DPI Port 4
22 = DPI Port 5
23 = Reserved

Default: 2 = Analog In 2

Access: 1 **Path:** Speed Command>Process PI

See also: 124-138

Selects the source of the PI feedback signal.

129 PI Integral Time

Range: 0.00 to 100.00 sec [0.01 sec]

Default: 2.00 sec

Access: 1 **Path:** Speed Command>Process PI

See also: 124-138

Specifies the time required for the integral component to reach 100% of PI Error Meter (137).

130 PI Prop Gain

Range: 0.00 to 100.00 [0.01]

Default: 1.00

Access: 1 **Path:** Speed Command>Process PI

See also: 124-138

Sets the value for the PI proportional component when the PI Hold bit of PI Control (125) is set to 1=Enabled.

$PI\ Error \times PI\ Prop\ Gain = PI\ Output$

131 PI Lower Limit

Range: -/+Maximum Frequency [0.1 Hz]
Default: -Maximum Freq
Access: 1 **Path:** Speed Command>Process PI
See also: 124-138

Sets the lower limit of the PI output. This value must be less than the value set in PI Upper Limit (132).

132 PI Upper Limit

Range: -/+Maximum Frequency [0.1 Hz]
Default: +Maximum Freq
Access: 1 **Path:** Speed Command>Process PI
See also: 124-138

Sets the upper limit of the PI output. This value must be greater than the value set in PI Lower Limit (131).

133 PI Preload

Range: -/+Maximum Frequency [0.1 Hz]
Default: 0.0 Hz
Access: 1 **Path:** Speed Command>Process PI
See also: 124-138

Sets the value used to load into the PI Integrator when PI is not enabled.

134 PI Status

Range:	See figure 9.12
Default:	Read Only
Access:	1 Path: Speed Command>Process PI
See also:	124-138

The present state of the process PI regulator.

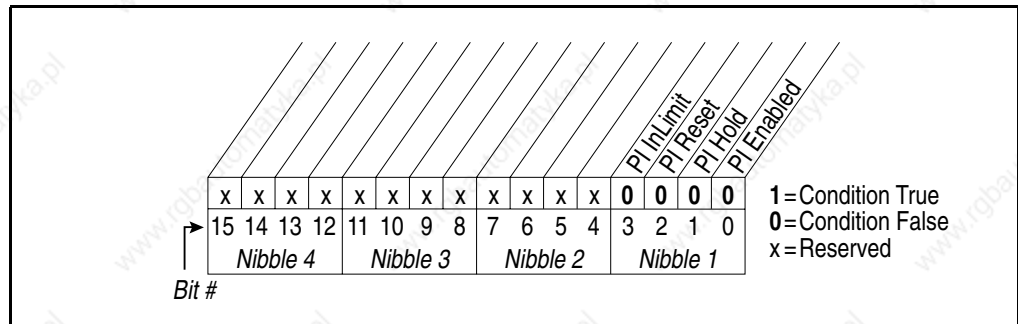

Figure 9.12 – PI Status (134)

Bit 0 - PI Enabled

- Indicates whether or not the PI loop is enabled.

Bit 1 - PI Hold

- Is set to 1 to indicate when a digital input is configured for PI Hold and is turned on, or the PI Hold bit is set in PI Control (125).

Bit 2 - PI Reset

- Is set to 1 to indicate when the PI Integrator is being reset to zero.

Bit 3 - PI InLimit

- Is set to 1 to indicate when the PI output equals positive limit or negative limit.

135 PI Ref Meter

Range:	-/+100.00% [0.01%]
Default:	Read Only
Access:	1 Path: Speed Command>Process PI
See also:	124 - 138

Present value of the PI reference signal.

136 PI Fdbck Meter

Range:	-/+100.00% [0.01%]
Default:	Read Only
Access:	1 Path: Speed Command>Process PI
See also:	124-138

Present value of the PI feedback signal.

137 PI Error Meter

Range: -/+100.00% [0.01%]
Default: Read Only
Access: 1 **Path:** Speed Command>Process PI
See also: 124-138

Present value of the PI error signal.

138 PI Output Meter

Range: -/+Maximum Freq [0.1 Hz]
Default: Read Only
Access: 1 **Path:** Speed Command>Process PI
See also: 124-138

Present value of the PI output signal.

140 Accel Time 1

141 Accel Time 2

Range: 0.1 to 100.0 [0.1 sec]
Default: 10.0
Access: 140=0 **Path:** Dynamic Control>Ramp Rates
141=0
See also: 142, 143, 146, 361-366

The Accel Time parameters set the rate at which the drive ramps to its output frequency after a start command or during an increase in command frequency (speed change). The rate established is the result of the following equation:

$$(\text{Maximum Speed} / \text{Accel Time}) = \text{Accel Rate}$$

Two accel times exist to enable acceleration rate changes “on the fly” using a building automation system command or digital input, if configured.

142 Decel Time 1

143 Decel Time 2

Range: 0.1 to 100.0 sec [0.1 sec]
Default: 10.0 sec
Access: 142=0 **Path:** Dynamic Control>Ramp Rates
143=0
See also: 142, 143, 146, 361-366

Sets the rate of deceleration for all speed decreases.

(Max Speed / Decel Time) = Decel Rate

Two decel times exist to enable deceleration rate changes “on the fly” using a building automation system command or digital input, if configured.

146 S Curve %

Range: 0 to 100% [1%]
Default: 0%
Access: 0 **Path:** Dynamic Control>Ramp Rates
See also: 140 - 143

Sets the percentage of acceleration or deceleration time that is applied to the ramp as S Curve. Time is added; 1/2 at the beginning and 1/2 at the end of the ramp.

147 Current Lmt Sel



Range: 0 = Curr Lim Val
1 = Analog In 1
2 = Analog In 2
Default: 0 = Cur Lim Val
Access: 0 **Path:** Dynamic Control>Load Limits
See also: 148, 149

Selects the source for the adjustment of current limit (i.e., parameter, analog input, etc.).

148 Current Lmt Val

Range: Based on Drive Type [0.1 Amps]
Default: Based on Drive Type (approximately 150%)
Access: 0 **Path:** Dynamic Control>Load Limits
See also: 147, 149

Defines the current limit value when Current Lmt Sel (147) = Cur Lim Val.

149 Current Lmt Gain

Range: 0 to 5000 [1]
Default: 200
Access: 1 **Path:** Dynamic Control>Load Limits
See also: 147, 148

Sets the responsiveness of the current limit.

150 Drive OL Mode

Range: 0 = Disabled
1 = Reduce CLim
2 = Reduce PWM
3 = Both-PWM 1st
Default: 0 = Disabled
Access: 1 **Path:** Dynamic Control>Load Limits
See also: 219

Selects the drive's response to increasing drive temperature.

151 PWM Frequency

Range: 2 - 4 kHz [1 kHz]
Default: 2 kHz
Access: 1 **Path:** Dynamic Control>Load Limits
See also: 146, 149

Sets the carrier frequency for the PWM output. Drive derating may occur at higher carrier frequencies. For derating information, refer to Appendix A.

155 Stop Mode A

156 Stop Mode B

Range: 0 = Coast
1 = Ramp
2 = Ramp to Hold
3 = DC Brake
Default: 155: 0 = Coast
156: 0 = Coast
Access: 155=0 **Path:** Dynamic Control>Stop/Brake Modes
156=0
See also: 157-159, 361-366

Active stop mode. Stop Mode A is active unless Stop Mode B is selected by a digital input.



ATTENTION: The user must provide an external, hardwired emergency stop circuit outside of the drive circuitry. This circuit must disable the system in case of improper operation. Uncontrolled machine operation may result if this procedure is not followed. Failure to observe this precaution could result in bodily injury.

157 DC Brake Lvl Sel

Range: 0 = DC Brake Lvl
1 = Analog In 1
2 = Analog In 2
Default: 0 = DC Brake Lvl
Access: 0 **Path:** Dynamic Control>Stop/Brake Modes
See also: 155, 156, 158, 159

Selects the source for DC Brake Level (158).

158 DC Brake Level

Range: 0 to (Rated Amps x 1.5) [0.1 Amps]
Default: Rated Amps
Access: 0 **Path:** Dynamic Control>Stop/Brake Modes
See also: 157-159

Defines the maximum DC brake current in percentage of drive rated current.

The DC braking voltage used in this function is created by a PWM algorithm and may not generate the smooth holding force needed for some applications.



ATTENTION: If a hazard of injury due to movement of equipment or material exists, an auxiliary mechanical braking device must be used to stop the motor. Failure to observe this precaution could result in severe bodily injury or loss of life.

ATTENTION: This feature should not be used with synchronous or permanent magnet motors. Motors may be demagnetized during braking. Failure to observe this precaution could result in damage to, or destruction of, the equipment.

159 DC Brake Time

Range: 0.0 to 90.0 sec [0.1 sec]
Default: 0.0 sec
Access: 0 **Path:** Dynamic Control>Stop/Brake Modes
See also: 155 - 158

Sets the amount of time DC brake current is “injected” into the motor.

160 Bus Reg Ki

Range: 0 to 5000 [1]
Default: 450
Access: 1 **Path:** Dynamic Control>Stop/Brake Modes
See also: 161, 162

Sets the responsiveness of the bus regulator.

161 Bus Reg Mode A
162 Bus Reg Mode B



Range: 0 = Disabled
1 = Adjust Freq
2 = Dynamic Brak
3 = Both - DB 1st
4 = Both - Frq 1st

Default: Mode A: 0 = Disabled
Mode B: 0 = Disabled

Access: 0 **Path:** Dynamic Control>Stop/Brake Modes

See also: 160, 163, 361-366

Sets the method and sequence of the DC bus regulator voltage. Choices are dynamic brake, frequency adjust, or both.

Sequence is determined by programming or digital input to the terminal block.

If a dynamic brake resistor is connected to the drive, Bus Reg Mode A and Bus Reg Mode B must be set to option 2, 3, or 4.

In LiquiFlo 2.0, this parameter should always be set to 0 = Disabled.



ATTENTION: The adjust freq portion of the bus regulator function is extremely useful for preventing nuisance overvoltage faults resulting from aggressive decelerations, overhauling loads, and eccentric loads. It forces the output frequency to be greater than commanded frequency while the drive's bus voltage is increasing towards levels that would otherwise cause a fault. However, it can also cause either of the following two conditions to occur:

- Fast positive changes in input voltage (more than a 10% increase within 6 minutes) can cause uncommanded positive speed changes; however, an OverSpeed Limit fault will occur if the speed reaches Max Speed + Overspeed Limit. If this condition is unacceptable, action should be taken to 1) limit supply voltages within the specification of the drive, and 2) limit fast positive input voltage changes to less than 10%. Without taking such actions, if this operation is unacceptable, the adjust freq portion of the bus regulator function must be disabled (see parameters 161 and 162).
- Actual deceleration times can be longer than commanded deceleration times; however, a Decel Inhibit fault is generated if the drive stops decelerating altogether. If this condition is unacceptable, the adjust freq portion of the bus regulator must be disabled (see parameters 161 and 162). In addition, installing a properly sized dynamic brake resistor will provide equal or better performance in most cases.

Note that these faults are not instantaneous and have shown test results that take between 2 and 12 seconds to occur.

163 DB Resistor Type

Range: 0 = Internal Res
1 = External Res
2 = None
Default: 2 = None
Access: 0 **Path:** Dynamic Control>Stop/Brake Modes
See also: 161, 162

Selects whether the internal or an external DB resistor will be used.

164 Bus Reg Kp

Range: 0 to 10000
Default: 1200
Access: 1 **Path:** Dynamic Control>Stop/Brake Modes
See also:

Proportional gain for the bus regulator. Used to adjust regulator response.

165 Bus Reg Kd

Range: 0 to 10000
Default: 1000
Access: 1 **Path:** Dynamic Control>Stop/Brake Modes
See also:

Derivative gain for the bus regulator. Used to control regulator overshoot.

168 Start At PowerUp

Range: 0 = Disabled
Default: 0 = Disabled
Access: 0 **Path:** Dynamic Control>Stop/Restart Modes
See also:

This parameter is not used with LiquiFlo AC drives.

169 Flying Start En

Range: 0 = Disabled
1 = Enabled
Default: 0 = Disabled
Access: 1 **Path:** Dynamic Control>Stop/Restart Modes
See also: 170

Enables/disables the function which reconnects to a spinning motor at actual RPM when a start command is issued.

170 Flying StartGain

Range:	20 to 32767 [1]
Default:	4000
Access:	1 Path: Dynamic Control>Restart Modes
See also:	169

Adjusts the responsiveness of the flying start function. Increasing the value in this parameter increases the responsiveness of the flying start function.

174 Auto Rstrt Tries

Range:	0 to 9 [1]
Default:	0 (Disabled)
Access:	0 Path: Dynamic Control>Restart Modes
See also:	175



ATTENTION: Equipment damage and/or personal injury may result if parameter 174 is used in an inappropriate application. Do not use this function without considering applicable local, national, and international codes, standards, regulations, or industry guidelines.

ATTENTION: The drive may start immediately after a fault is auto-reset when LevelSense Start (168) is set to Enabled.

When LevelSense Start is enabled, the user must ensure that automatic start up of the driven equipment will not cause injury to operating personnel or damage to the driven equipment. In addition, the user is responsible for providing suitable audible or visual alarms or other devices to indicate that this function is enabled and the drive may start at any moment. Failure to observe this precaution could result in severe bodily injury or loss of life.

Important: The drive will re-start after a reset if the start input is still asserted.

Specifies the maximum number of times the drive attempts to reset a fault and restart when the auto restart feature is enabled.

The auto restart feature provides the ability for the drive to automatically perform a fault reset followed by a start attempt without user or application intervention. Only certain faults are permitted to be reset, see chapter 10 for more information.

When the auto restart feature is enabled (that is, Auto Rstrt Tries is set to a value greater than zero), and an auto-resettable fault occurs, the drive will stop. After the number of seconds in Auto Rstrt Delay (175) has elapsed, the drive will automatically reset the faulted condition. The drive will then issue an internal start command to start the drive.

If another auto-resettable fault occurs, the cycle will repeat up to the number of attempts specified in Auto Rstrt Tries.

If the drive faults repeatedly for more than the number of attempts specified in Auto Rstrt Tries with less than five minutes between each fault, the drive will remain in the faulted state. The fault Auto Rstrt Tries will be logged in the fault queue.

The auto restart feature is disabled when the drive is stopping and during autotuning. Note that a DC Hold state is considered stopping.

The following conditions will abort the reset/run process:

- Issuing a stop command from any control source. (Note that removal of a 2-wire run-fwd or run-rev command is considered a stop command.)
- Issuing a fault reset command from any active source.
- Removing the enable input signal.
- Setting Auto Rstrt Tries to zero.
- Occurrence of a fault that is not auto-resettable.
- Removing power from the drive.
- Exhausting an auto-reset/run cycle.

Note that two autotuning status bits are provided in Drive Status 2 (210): an active status bit and a countdown status bit.

175 Auto Rstrt Delay

Range: 0.5 to 30.0 sec [0.1 sec]
Default: 1.0 sec
Access: 0 **Path:** Dynamic Control>Restart Modes
See also: 174

Sets the time between restart attempts when the auto restart feature is enabled. Refer to Auto Rstrt Tries (174) for more information about the auto restart feature.

178 Sleep-Wake Mode



Range: 0 = Disabled
Default: 0 = Disabled
Access: 1 **Path:** Dynamic Control>Restart Modes
See also:

Enables the Sleep-Wake function. This parameter is not used with LiquiFlo AC drives.

179 Sleep-Wake Ref



Range: 1 = Analog In 1
2 = Analog In 2
Default: 2 = Analog In 2
Access: 1 **Path:** Dynamic Control>Restart Modes
See also:

Selects the source of the input controlling the Sleep-Wake function. This parameter is not used with LiquiFlo AC drives.

180 Wake Level



Range: Sleep Level / 20.000 mA, 10.000 volts [0.001 mA, 0.001 V]
Default: 6.000 mA, 6.000 V
Access: 1 **Path:** Dynamic Control>Restart Modes
See also: 181

Defines the analog input level that will start the drive. This parameter is not used with LiquiFlo AC drives.

181 Wake Time

Range: 0.0 to 30.0 [0.1 sec]
Default: 1.0
Access: 1 **Path:** Dynamic Control>Restart Modes
See also: 180

Defines the amount of time at or above Wake Level before a start command is issued. This parameter is not used with LiquiFlo AC drives.

182 Sleep Level



Range: 4.000 mA, 0.000 V / Wake Level [0.001 mA, 0.001 V]
Default: 5.000 mA, 5.000 V
Access: 1 **Path:** Dynamic Control>Restart Modes
See also: 183

Defines the analog input level that will stop the drive. This parameter is not used with LiquiFlo AC drives.

183 Sleep Time

Range: 0.0 to 30.0 [0.1 sec]
Default: 1.0
Access: 1 **Path:** Dynamic Control>Restart Modes
See also: 182

Defines the amount of time at or below Sleep Level before a stop command is issued. This parameter is not used with LiquiFlo AC drives.

184 Power Loss Mode

Range:	0 = Coast 1 = Decel 2 = Continue 3 = Coast input 4 = Decel input
Default:	0 = Coast
Access:	0 Path: Dynamic Control>Power Loss
See also:	184

Sets the reaction to a loss of input power. Power loss is recognized when:

- DC bus voltage is $\leq 73\%$ of DC Bus Memory and Power Loss Mode is set to Coast.
- DC bus voltage is $\leq 82\%$ of DC Bus Memory and Power Loss Mode is set to Decel.

185 Power Loss Time

Range:	0.0 to 60.0 sec [0.1 sec]
Default:	0.5 sec
Access:	0 Path: Dynamic Control>Power Loss
See also:	184

Sets the time that the drive will remain in power loss mode before a fault is issued.

186 Power Loss Level

Range:	0.0 to 999.9 [0.1 VDC]
Default:	Drive Rated Volts
Access:	1 Path: Dynamic Control>Power Loss
See also:	184

When set to a non-zero value, selects the change in level at which the Power Loss will occur.

190 Direction Mode



Range: 0 = Unipolar
1 = Bipolar
2 = Reverse Dis

Default: 2 = Reverse Dis

Access: 0 **Path:** Utility>Direction Config

See also: 320 - 327, 361 - 366

Selects the source for control of drive direction.



ATTENTION: Setting parameter 190 to 0 or 1 may cause unwanted motor direction. Verify driven machinery cannot be damaged by reverse rotation before changing the setting of this parameter to 0 or 1. Failure to observe this precaution could result in damage to, or destruction of, equipment.

0 = Unipolar: Drive receives unsigned reference (0 to 32767) and direction command separately (from the DPI port). For example, the direction keys on an OIM apply the direction to the reference.

1 = Bipolar: Drive receives signed reference (-32767 to 32767). In this case, the direction keys have no effect.

2 = Reverse Disable: Drive receives signed reference (-32767 to 32767); however, regardless of the reference, the drive is not permitted to reverse.

192 Save OIM Ref

Range: See figure 9.13

Default: See figure 9.13

Access: 1 **Path:** Utility>OIM Ref Config

See also:

Enables a feature to save the present frequency reference value issued by the OIM to drive memory on power loss. Value is restored to the OIM on power up.

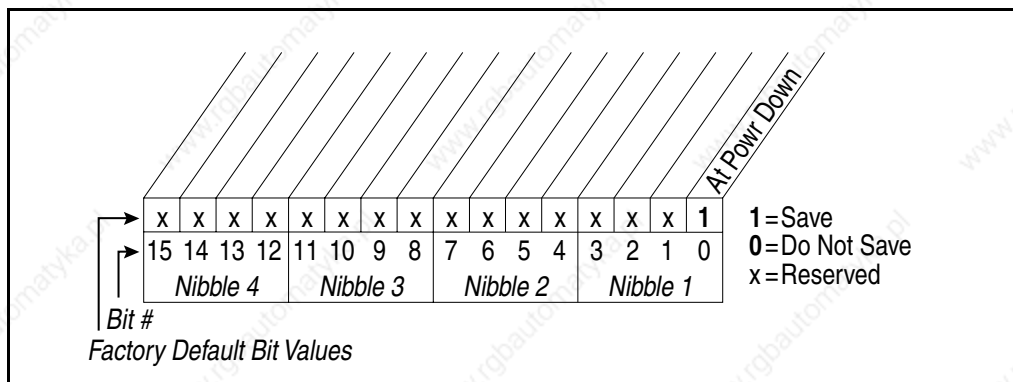

Figure 9.13 – Save OIM Ref (192)

193 Man Ref Preload

Range: 0 = Disabled
1 = Enabled
Default: 0 = Disabled
Access: 1 **Path:** Utility>OIM Ref Config
See also: 320 - 327, 361 - 366

Enables/disables a feature to automatically load the present auto frequency reference value into the OIM when Manual is selected. Allows smooth speed transition from Auto to Manual.

194 Save MOP Ref

Range: See figure 9.14
Default: See figure 9.14
Access: 1 **Path:** Utility>MOP Config
See also:

Enables/disables the feature that saves the present MOP (motor-operated potentiometer) frequency reference at power down or at stop.

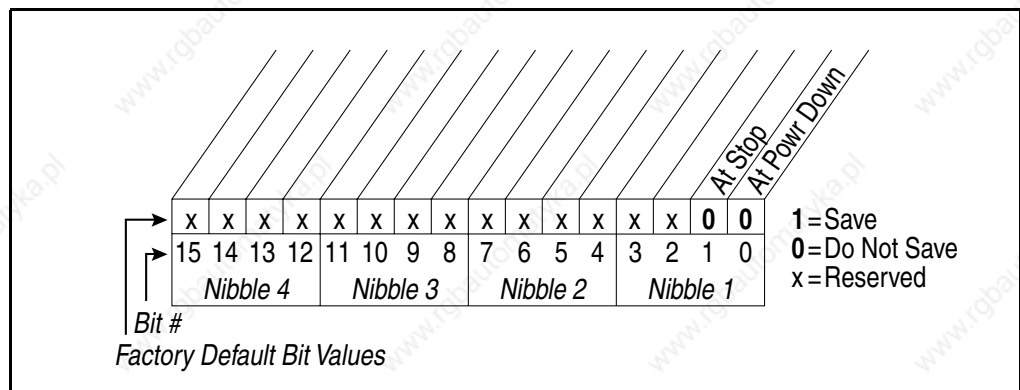

Figure 9.14 – Save MOP Ref (194)

195 MOP Rate

Range: 0.2 to 250.0 [0.1 Hz/sec]
Default: 1.0 Hz/sec
Access: 1 **Path:** Utility>MOP Config
See also:

Sets the rate of change of the MOP reference in response to a digital input.

196 Param Access Lvl

Range: 0 = Basic
1 = Advanced

Default: 0

Access: 0 **Path:** Utility>Drive Memory

See also:

Displays the present parameter access level. Refer to chapter 3 for more information about parameter access levels.

197 Restore Defaults

Range: 0 = Ready
1 = Factory
2 = Low Voltage
3 = High Voltage

Default: 0 = Ready

Access: 0 **Path:** Utility>Drive Memory

See also:

Resets all parameter values to defaults. Option 1 resets the drive to factory settings. Options 2 and 3 resets the drive to alternate voltage and current rating.

198 Load Frm Usr Set

Range: 0 = Ready
1 = User Set 1
2 = User Set 2
3 = User Set 3

Default: 0 = Ready

Access: 0 **Path:** Utility>Drive Memory

See also: 199

Loads a previously saved set of parameter values from a selected user set location in drive non-volatile memory to active drive memory.

An F-Key on the LCD OIM can be configured for this function. Refer to appendix B.

199 Save To User Set

Range: 0 = Ready
1 = User Set 1
2 = User Set 2
3 = User Set 3

Default: 0 = Ready

Access: 0 **Path:** Utility>Drive Memory

See also: 198

Saves the parameter values in active drive memory to a user set in drive non-volatile memory.

An F-Key on the LCD OIM can be configured for this function. Refer to appendix B.

200 Reset Meters

Range: 0 = Ready
1 = MWh
2 = Elapsed Time
Default: 0 = Ready
Access: 1 **Path:** Utility>Drive Memory
See also:

Resets selected meters to zero.

201 Language

Range: 0 = Not Selected
1 = English
2 = Francais
3 = Espanol
4 = Italiano
5 = Deutsch
6 = Reserved
7 = Portugues
8 = Dutch
Default: 0 = Not Selected
Access: 0 **Path:** Utility>Drive Memory
See also:

Selects the display language when using an LCD OIM.

202 Voltage Class



Range: 2 = Low Voltage
3 = High Voltage
Default: Based on Drive Type
Access: 1 **Path:** Utility>Drive Memory
See also: 55

Resets selected parameters that change the drive voltage rating, current rating, scaling, and motor data. Maximum Frequency (55) will be affected by changing this parameter.

203 Drive Checksum

Range: 0 to 65535 [1]
Default: Read Only
Access: 1 **Path:** Utility>Drive Memory
See also:

Provides a checksum value that indicates whether or not a change in drive programming has occurred (data values only).

209 Drive Status 1

Range: See figure 9.15

Default: Read Only

Access: 1 **Path:** Utility>Diagnostics

See also: 210

Present operating condition of the drive.

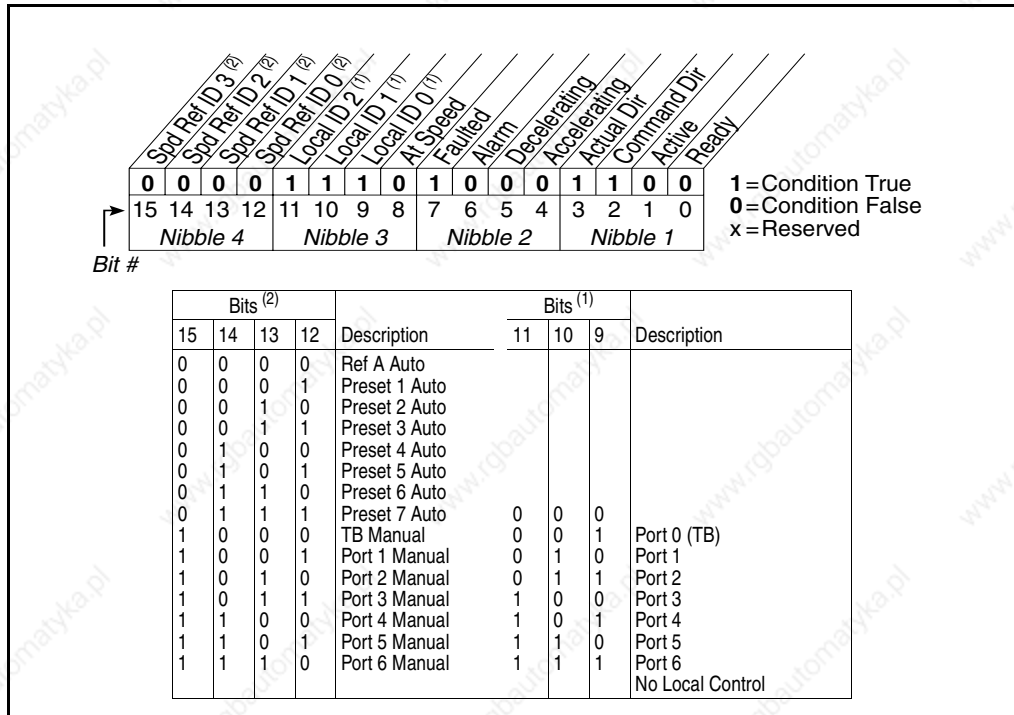

Figure 9.15 – Drive Status 1 (209)

211 Drive Alarm 1

Range:	See figure 9.17		
Default:	Read Only		
Access:	1	Path:	Utility>Diagnostics Utility>Alarms
See also:	212, 259		

Indicates Type 1 alarm conditions that currently exist in the drive. Note that for alarm conditions not configured in Alarm Config 1 (259), the status indicated will be a zero.

Refer to chapter 10, Troubleshooting the Drive, for more information about alarms.

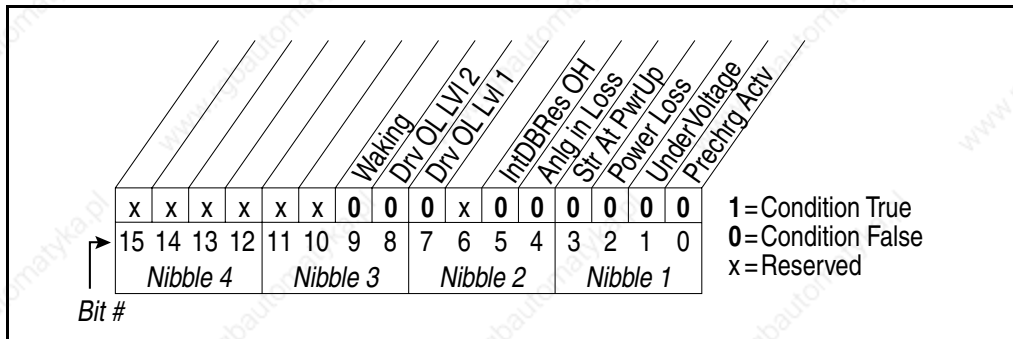

Figure 9.17 – Drive Alarm 1 (211)

212 Drive Alarm 2

Range:	See figure 9.18		
Default:	Read Only		
Access:	1	Path:	Utility>Diagnostics Utility>Alarms
See also:	211		

Indicates Type 2 alarm conditions that currently exist in the drive. Refer to chapter 10, Troubleshooting the Drive, for more information about alarms.

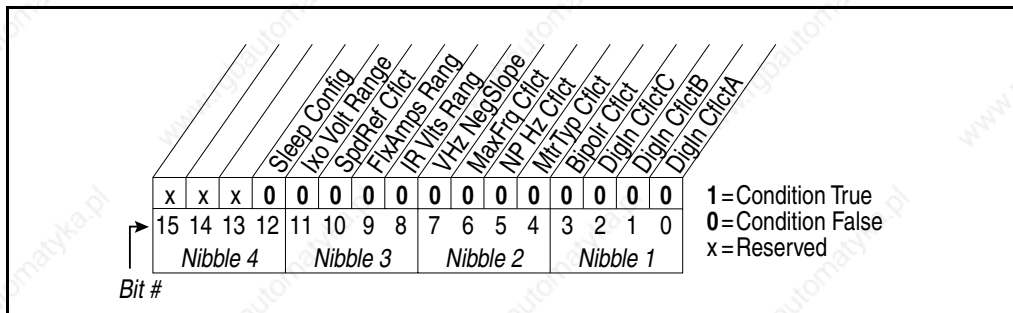

Figure 9.18 – Drive Alarm 2 (212)

213 Speed Ref Source

Range: 0 = PI Output
 1 = Analog In 1
 2 = Analog In 2
 3-8 = Reserved
 9 = MOP Level
 10 = Jog Speed
 11 = Preset Spd 1
 12 = Preset Spd 2
 13 = Preset Spd 3
 14 = Preset Spd 4
 15 = Preset Spd 5
 16 = Preset Spd 6
 17 = Preset Spd 7
 18 = Network
 19 = DPI Port 2
 20 = DPI Port 3
 21 = DPI Port 4
 22 = DPI Port 5

Default: Read Only

Access: 1 **Path:** Utility>Diagnostics

See also: 90, 93, 96, 101

Displays the source of the speed reference of the drive.

214 Start Inhibits

Range: See figure 9.19

Default: Read Only

Access: 0 **Path:** Utility>Diagnostics

See also:

Displays the inputs currently preventing the drive from starting.

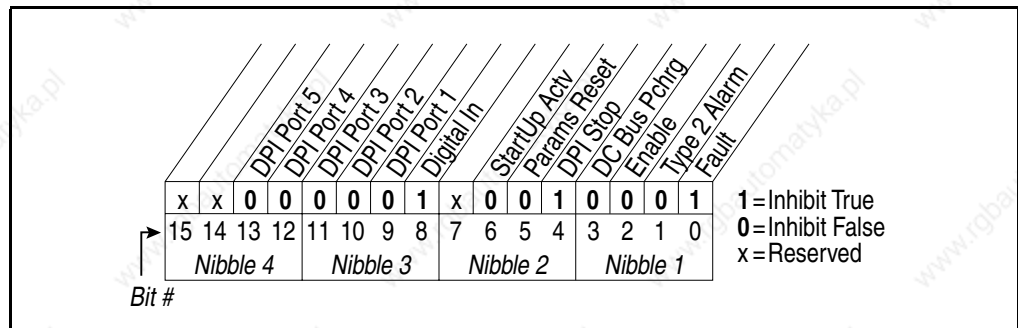

Figure 9.19 – Start Inhibits (214)

215 Last Stop Source

Range: 0 = Pwr Removed
1 = Network
2 = DPI Port 2
3 = DPI Port 3
4 = DPI Port 4
5 = DPI Port 5
6 = Reserved
7 = Digital In
8 = Fault
9 = Not Enabled
10 = Sleep
11 = Jog

Default: Read Only

Access: 1 **Path:** Utility>Diagnostics

See also:

Displays the source that initiated the most recent stop sequence. It will be cleared (set to 0) during the next start sequence.

216 Dig In Status

Range: See figure 9.20

Default: Read Only

Access: 0 **Path:** Utility>Diagnostics

See also: 361-366

Current state of the digital inputs on the terminal block.

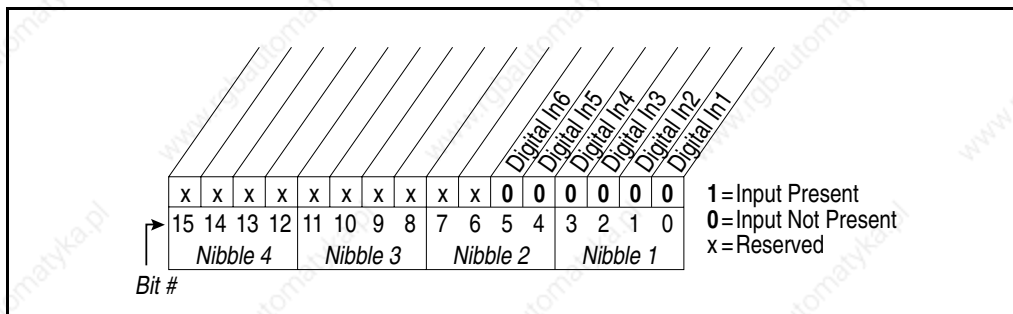

Figure 9.20 – Dig In Status (216)

217 Dig Out Status

Range: See figure 9.21
Default: Read Only
Access: 0 **Path:** Utility>Diagnostics
See also: 380-384

Current state of the digital outputs.

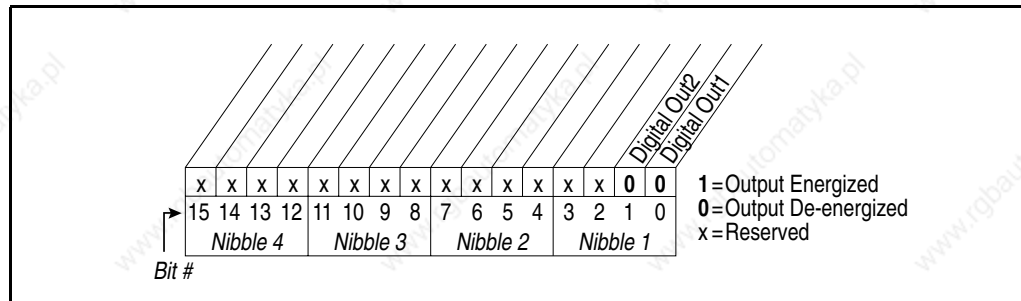

Figure 9.21 – Dig Out Status (276)

218 Invtr Base Temp

Range: -/+100 degC [0.1 degC]
Default: Read Only
Access: 1 **Path:** Utility>Diagnostics
See also:

Present operating temperature of the drive power section.

219 Drive OL Count

Range: 0.0 to 100.0% [0.1%]
Default: Read Only
Access: 1 **Path:** Utility>Diagnostics
See also: 150

Accumulated percentage of drive overload. Continuously operating the drive over 100% of its rating will increase this value to 100% and cause a drive fault.

220 Motor OL Count

Range: 0.0 to 100.0 [1.0%]
Default: Read Only
Access: 1 **Path:** Utility>Diagnostics
See also: 47, 48

Accumulated percentage of motor overload. Continuously operating the motor over 100% of the motor overload setting will increase this value to 100% and cause a drive fault.

221 Imbalance Count

Range: 0.0 to 100.0 [1.0%]
Default: Read Only
Access: 1 **Path:** Utility>Diagnostics
See also: 49, 50

Displays the imbalance in current between motor phases.

224 Fault Frequency

Range: 0.0 to +/-400.0 Hz [0.1 Hz]
Default: Read Only
Access: 1 **Path:** Utility>Diagnostics
See also: 225-230

Captures and displays the output frequency of the drive at the time of the last fault.

225 Fault Amps

Range: 0.0 to Rated Amps x 2 [0.1 Amps]
Default: Read Only
Access: 1 **Path:** Utility>Diagnostics
See also: 224-230

Captures and displays motor amps at the time of the last fault.

226 Fault Bus Volts

Range: 0.0 to Max Bus Volts [0.1 VDC]
Default: Read Only
Access: 1 **Path:** Utility>Diagnostics
See also: 224-230

Captures and displays the DC bus voltage of the drive at the time of the last fault.

227 Status 1 @ Fault

Range:	See figure 9.22
Default:	Read Only
Access:	1 Path: Utility>Diagnostics
See also:	209, 224-230

Captures and displays Drive Status 1 bit pattern at the time of the last fault.

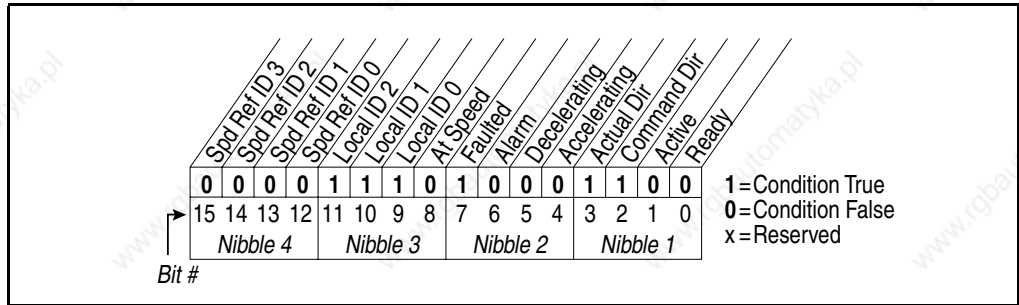

Figure 9.22 – Status 1 @ Fault (227)

228 Status 2 @ Fault

Range:	See figure 9.23
Default:	Read Only
Access:	1 Path: Utility>Diagnostics
See also:	210, 224-230

Captures and displays Drive Status 2 bit pattern at the time of last fault.

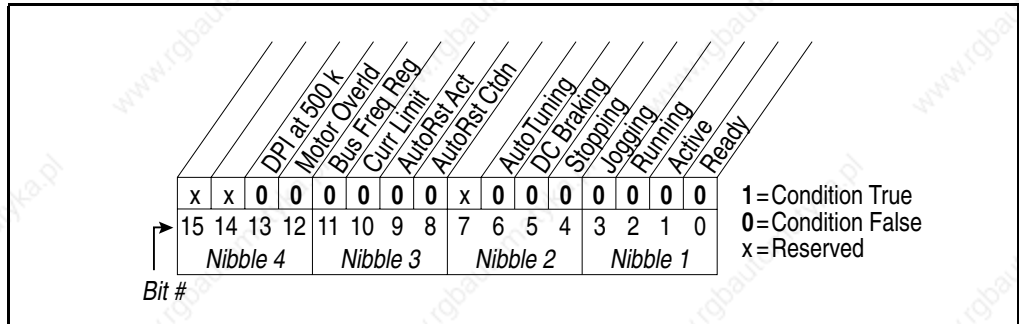

Figure 9.23 – Status 2 @ Fault (228)

229 Alarm 1 @ Fault

Range: See figure 9.24
Default: Read Only
Access: 1 **Path:** Utility>Diagnostics
See also: 211, 224-230

Captures and displays Drive Alarm 1 at the time of the last fault.

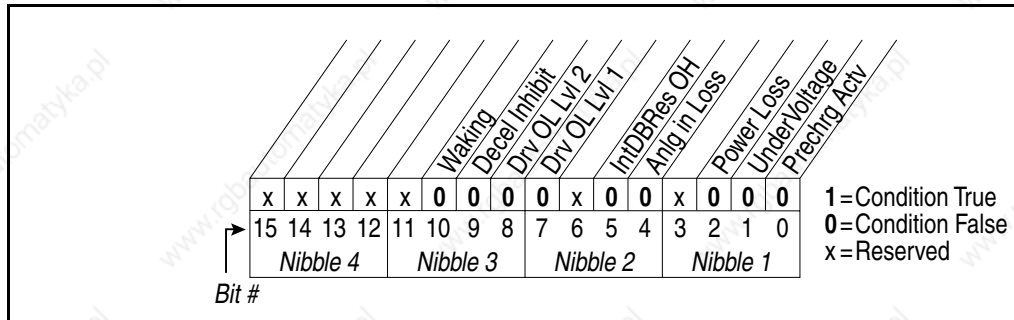

Figure 9.24 – Alarm 1 @ Fault (229)

230 Alarm 2 @ Fault

Range: See figure 9.25
Default: Read Only
Access: 1 **Path:** Utility>Diagnostics
See also: 211, 221-230

Captures and displays Drive Alarm 2 bit pattern at the time of last fault.

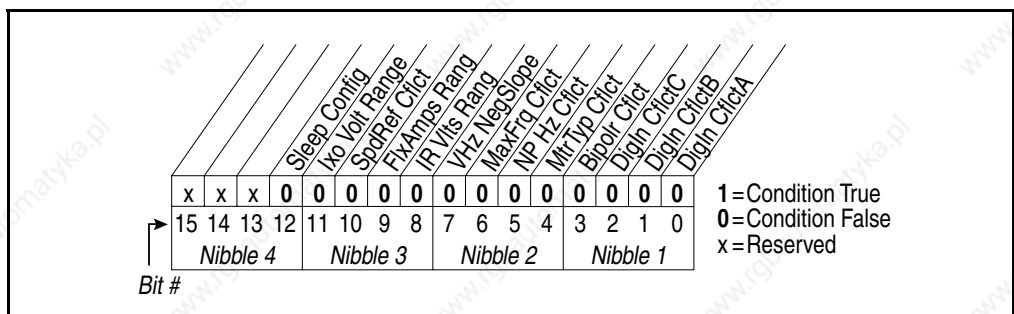

Figure 9.25 – Alarm 2 @ Fault (230)

234 Testpoint 1 Sel

Range: 0 to 65535 [1]
Default: 499
Access: 1 **Path:** Utility>Diagnostics
See also: 235

Selects the function whose value is displayed in Testpoint 1 Data (235). These are internal values that are not accessible through parameters.

See Testpoint Codes and Functions in chapter 10 for a list of codes and functions.

235 Testpoint 1 Data



Range: 0 to 4,294,697,295 [1]
Default: 0
Access: 1 **Path:** Utility>Diagnostics
See also: 234

The present value of the function selected in Testpoint 1 Sel (234).

236 Testpoint 2 Sel

Range: 0 to 65535 [1]
Default: 499
Access: 1 **Path:** Utility>Diagnostics
See also: 237

Selects the function whose value is displayed in Testpoint 2 Data (237). These are internal values that are not accessible through parameters.

See Testpoint Codes and Functions in chapter 10 for a list of codes and functions.

237 Testpoint 2 Data



Range: 0 to 4,294,967,295 [1]
Default: 0
Access: 1 **Path:** Utility>Diagnostics
See also: 236

The present value of the function selected in Testpoint 2 Sel (236).

238 Fault Config 1

Range: See figure 9.26
Default: See figure 9.26
Access: 0 **Path:** Utility>Faults
See also:

Enables/disables annunciation of the faults shown in figure 9.26.

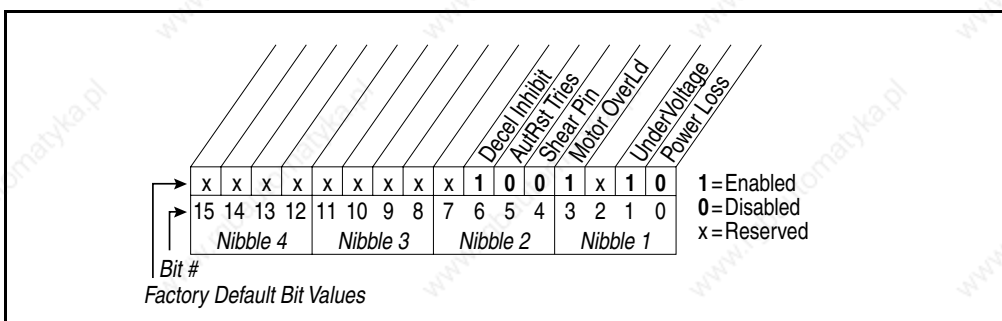

Figure 9.26 – Fault Config 1 (238)

240 Fault Clear

Range: 0 = Ready
1 = Clear Faults
2 = Clr Flt Que
Default: 0 = Ready
Access: 1 **Path:** Utility>Faults
See also:

Resets a fault and clears the fault queue.

241 Fault Clear Mode

Range: 0 = Disabled
1 = Enabled
Default: 1 = Enabled
Access: 1 **Path:** Utility>Faults
See also:

Enables/disables a fault reset (clear faults) attempt from any source. This does not apply to fault codes, which are cleared indirectly via other actions.

242 Power Up Marker

32

Range: 0.0000 to 4,294,967.2925 Hr [0.0001 Hr]
Default: Read Only
Access: 1 **Path:** Utility>Faults
See also: 244, 246, 248, 250

Elapsed hours since initial drive power up. This value will rollover to 0 after the drive has been powered on for more than the maximum value shown.

-
- 243 Fault 1 Code**
 - 245 Fault 2 Code**
 - 247 Fault 3 Code**
 - 249 Fault 4 Code**
 - 251 Fault 5 Code**
 - 253 Fault 6 Code**
 - 255 Fault 7 Code**
 - 257 Fault 8 Code**

Range: 0000 to 9999
Default: Read Only
Access: 1 **Path:** Utility>Faults
See also:

A code that represents a drive fault. The codes will appear in these parameters in the order they occur. Fault 1 Code = the most recent fault.

-
- 244 Fault 1 Time**
 - 246 Fault 2 Time**
 - 248 Fault 3 Time**
 - 250 Fault 4 Time**
 - 252 Fault 5 Time**
 - 254 Fault 6 Time**
 - 256 Fault 7 Time**
 - 258 Fault 8 Time**



Range: 0.0000 to 429,496.7295 [0.0001 Hr]
Default: Read Only
Access: 1 **Path:** Utility>Faults
See also: 242

The time between initial power up and the occurrence of the associated fault. Can be compared to Power Up Marker for the time from the most recent power up.

Fault x Time - Power Up Marker = the time difference to the most recent power up. A negative value indicates a fault occurred before the most recent power up. A positive value indicates a fault occurred after the most recent power up.

259 Alarm Config 1

Range: See figure 9.27
Default: See figure 9.27
Access: 1 **Path:** Utility>Alarms
See also:

Selects alarm conditions that will initiate a drive alarm. Refer to chapter 10, Troubleshooting the Drive, for more information about alarms.

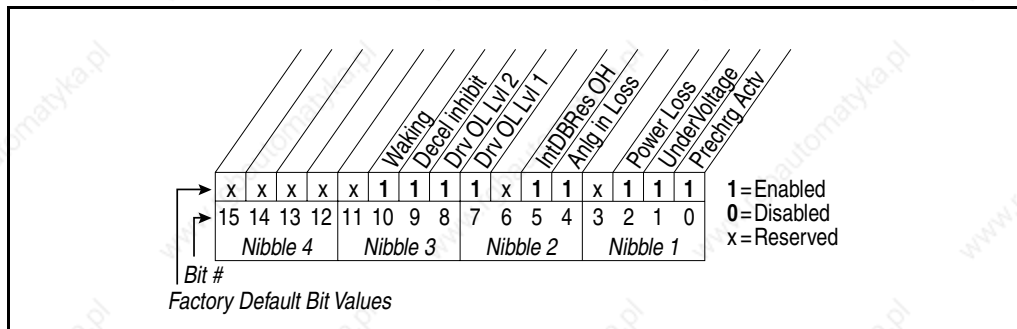

Figure 9.27 – Alarm Config 1 (259)

261 Alarm Clear

Range: 0 = Ready
1 = Clr Alarm Que
Default: 0 = Ready
Access: 1 **Path:** Utility>Alarms
See also: 262 - 269

Resets all Alarm1 - 8 Code parameters (262 - 269) to zero.

262 Alarm 1 Code

263 Alarm 2 Code

264 Alarm 3 Code

265 Alarm 4 Code

266 Alarm 5 Code

267 Alarm 6 Code

268 Alarm 7 Code

269 Alarm 8 Code

Range: 0 to 256
Default: Read Only
Access: 1 **Path:** Utility>Alarms
See also: 261

A code that represents a drive alarm. The codes will appear in the order that the alarms occur. The first code in is the first out. A time stamp is available with alarms.

270 DPI Data Rate



Range: 0 = 125 kbps
1 = 500 kbps

Default: 1

Access: 1 **Path:** Communication>Comm Control

See also:

For LiquiFlo 2.0 drives, this parameter must be set to 1 (500 kbps).

271 Drive Logic Rslt

Range: See figure 9.28

Default: Read Only

Access: 1 **Path:** Communication>Comm Control

See also:

The final logic command to the drive resulting from the combination of all port requests and masking functions. Each bit or set of bits represent a command to the drive or follower device. For LiquiFlo 2.0 drives, bit 6 will always = 0.

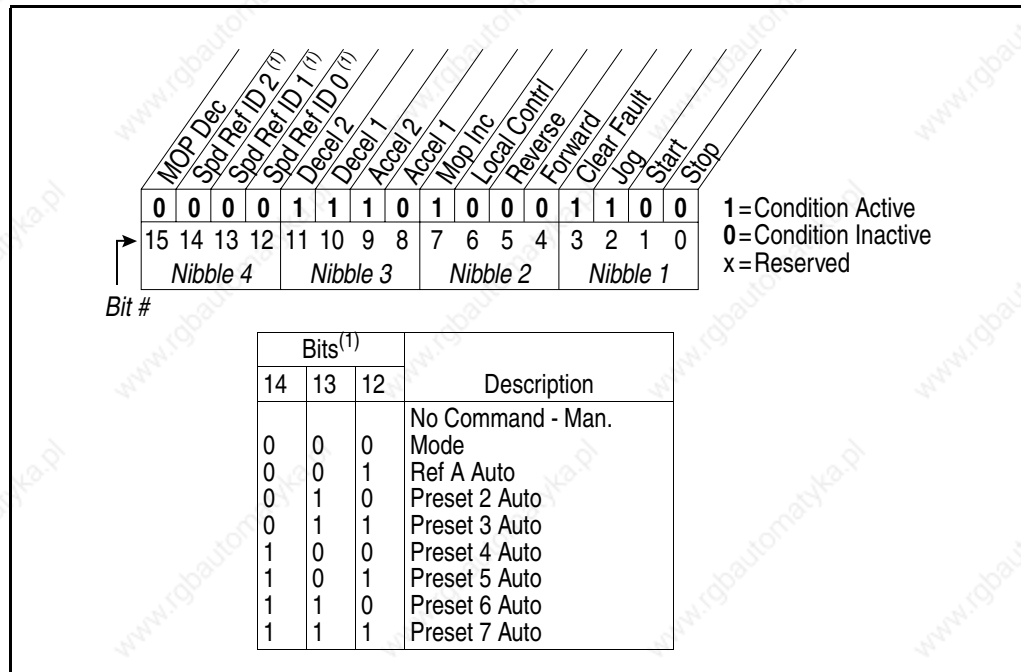

Figure 9.28 – Drive Logic Rslt (271)

272 Drive Ref Rslt

Range: -/+32767 [1]
Default: Read Only
Access: 1 **Path:** Communication>Comm Control
See also:

Present frequency reference scaled as a DPI reference for peer-to-peer communications. The value shown is the output prior to the accel/decel ramp and any corrections supplied by slip comp, PI, etc.

273 Drive Ramp Rslt

Range: -/+32767 [1]
Default: Read Only
Access: 1 **Path:** Communication>Comm Control
See also:

Present frequency reference scaled as a DPI reference for peer-to-peer communications. The value shown is the value after the accel/decel ramp but prior to any corrections supplied by slip comp, PI, etc.

276 Logic Mask



Range: See figure 9.29
Default: See figure 9.29
Access: 1 **Path:** Communication>Masks & Owners
See also: 288 - 297

Disables manual requests at the port corresponding to bit number.

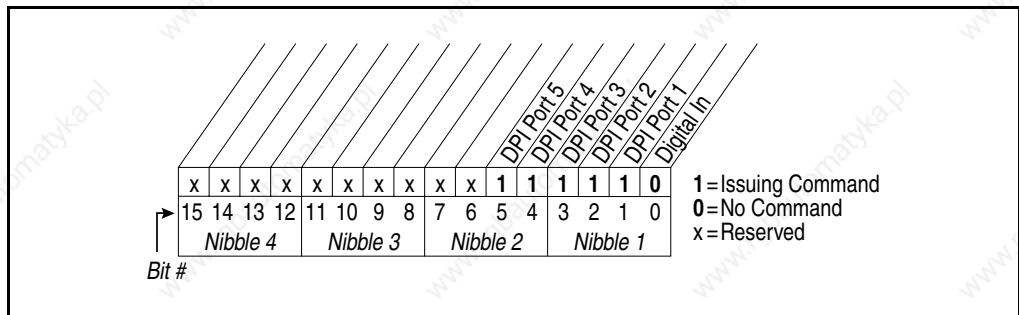

Figure 9.29 – Logic Mask (276)

277 Start Mask



Range: See Logic Mask (276)
Default: See Logic Mask (276)
Access: 1 **Path:** Communication>Masks & Owners
See also: 288 - 297

Controls which modules can issue start commands.

278 Jog Mask



Range: See Logic Mask (276)
Default: 0
Access: 1 **Path:** Communication>Masks & Owners
See also: 288 - 297

Controls which modules can issue jog commands.

279 Direction Mask



Range: See Logic Mask (276)
Default: 0
Access: 1 **Path:** Communication>Masks & Owners
See also: 288 - 297

Controls which modules can issue forward/reverse direction commands.

280 Reference Mask



Range: See Logic Mask (276)
Default: See Logic Mask (276)
Access: 1 **Path:** Communication>Masks & Owners
See also: 288 - 297

Controls which modules can select an alternate reference. Speed Ref A, B Sel or Preset 1 - 7 (90, 93, 101 - 107).

281 Accel Mask



Range: See Logic Mask (276)
Default: See Logic Mask (276)
Access: 1 **Path:** Communication>Masks & Owners
See also: 288 - 297

Controls which modules can select Accel Time 1, 2 (140, 141).

282 Decel Mask



Range: See Logic Mask (276)
Default: See Logic Mask (276)
Access: 1 **Path:** Communication>Masks & Owners
See also: 288 - 297

Controls which modules can select Decel Time 1, 2. (142, 143)

283 Fault Clr Mask



Range: See Logic Mask (276)
Default: See Logic Mask (276)
Access: 1 **Path:** Communication>Masks & Owners
See also: 288 - 297

Controls which modules can clear a fault.

284 MOP Mask



Range: See Logic Mask (276)
Default: See Logic Mask (276)
Access: 1 **Path:** Communication>Masks & Owners
See also: 288 - 297

Controls which modules can issue MOP commands to the drive.

285 Local Mask



Range: See Logic Mask (276)
Default: See Logic Mask (276)
Access: 1 **Path:** Communication>Masks & Owners
See also: 288 - 297

Controls which modules are allowed to take exclusive control of drive logic commands (except stop). Exclusive local control can be taken only when the drive is stopped.

288 Stop Owner

Range: See figure 9.30
Default: Read Only
Access: 1 **Path:** Communication>Masks & Owners
See also: 276 - 285

Modules that are presently issuing a valid stop command.

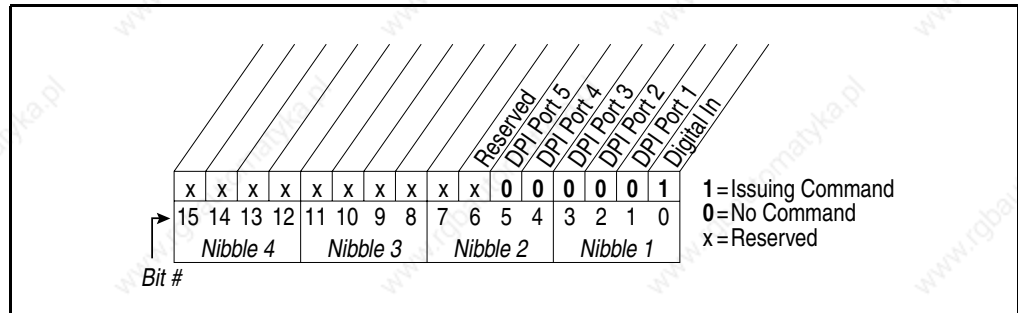

Figure 9.30 – Stop Owner

289 Start Owner

Range: See Stop Owner (288)
Default: Read Only
Access: 1 **Path:** Communication>Masks & Owners
See also: 276 - 285

Modules that are presently issuing a valid start command.

290 Jog Owner



Range: See Stop Owner (288)
Default: Read Only
Access: 1 **Path:** Communication>Masks & Owners
See also: 276 - 285

Modules that are presently issuing a valid jog command.

291 Direction Owner



Range: See Stop Owner (288)
Default: Read Only
Access: 1 **Path:** Communication>Masks & Owners
See also: 276 - 285

Module that currently has exclusive control of direction changes.

292 Reference Owner



Range: See Stop Owner (288)
Default: Read Only
Access: 1 **Path:** Communication>Masks & Owners
See also: 276 - 285

Module that currently has exclusive control of the command frequency source selection.

293 Accel Owner



Range: See Stop Owner (288)
Default: Read Only
Access: 1 **Path:** Communication>Masks & Owners
See also: 276 - 285

Module that currently has exclusive control of selecting Accel Time 1, 2.

294 Decel Owner



Range: See Stop Owner (288)
Default: Read Only
Access: 1 **Path:** Communication>Masks & Owners
See also: 276 - 285

Module that currently has exclusive control of selecting Decel Time 1, 2.

295 Fault Clr Owner



Range: See Stop Owner (288)
Default: Read Only
Access: 1 **Path:** Communication>Masks & Owners
See also: 276 - 285

Module that is presently clearing a fault.

296 MOP Owner



Range: See Stop Owner (288)
Default: Read Only
Access: 1 **Path:** Communication>Masks & Owners
See also: 276 - 285

Modules that are currently issuing increases or decreases in MOP command frequency.

297 Local Owner



Range: See Stop Owner (288)
Default: Read Only
Access: 1 **Path:** Communication>Masks & Owners
See also: 276 - 285

Module that has requested exclusive control of drive logic functions.

If an module is in local lockout, all other functions (except stop) on all other modules are locked out and non-functional. Local control can be obtained only when the drive is stopped.

300 Data In A1 - Link A Word 1

301 Data In A2 - Link A Word 2



Range: 0 to 387 [1]
Default: 0 (Disabled)
Access: 1 **Path:** Communication>Datalinks
See also:

Parameter number whose value will be written from a communications device data table.

Parameters that can be changed only while the drive is stopped cannot be used as Datalink inputs. Entering a parameter of this type will disable the link

Refer to the appropriate communications module manual for Datalink information.

302 Data In B1 - Link B Word 1

303 Data In B2 - Link B Word 2



Range: 0 to 387 [1]
Default: 0 (Disabled)
Access: 1 **Path:** Communication>Datalinks
See also:

Parameter number whose value will be written from a communications device data table.

Parameters that can be changed only while the drive is stopped cannot be used as Datalink inputs. Entering a parameter of this type will disable the link.

Refer to the appropriate communications module manual for Datalink information.

304 Data In C1 - Link C Word 1
305 Data In C2 - Link C Word 2



Range: 0 to 387 [1]
Default: 0 (Disabled)
Access: 1 **Path:** Communication>Datalinks
See also:

Parameter number whose value will be written from a communications device data table.

Parameters that can be changed only while the drive is stopped cannot be used as Datalink inputs. Entering a parameter of this type will disable the link.

Refer to the appropriate communications module manual for Datalink information.

306 Data In D1 - Link D Word 1
307 Data In D2 - Link D Word 2



Range: 0 to 387 [1]
Default: 306 = 34
307 = 35
Access: 1 **Path:** Communication>Datalinks
See also:

Parameter number whose value will be written from a communications device data table.

Parameters that can be changed only while the drive is stopped cannot be used as Datalink inputs. Entering a parameter of this type will disable the link.

Refer to the appropriate communications module manual for Datalink information.

310 Data Out A1- Link A Word 1
311 Data Out A2 - Link A Word 2

Range: 0 to 387 [1]
Default: 0 (Disabled)
Access: 1 **Path:** Communication>Datalinks
See also:

Parameter number whose value will be written to a communications device data table.

312 Data Out B1- Link B Word 1
313 Data Out B2 - Link B Word 2

Range: 0 to 387 [1]
Default: 0 (Disabled)
Access: 1 **Path:** Communication>Datalinks
See also:

Parameter number whose value will be written to a communications device data table.

314 Data Out C1- Link C Word 1
315 Data Out C2 - Link C Word 2

Range: 0 to 387 [1]
Default: 0 (Disabled)
Access: 1 **Path:** Communication>Datalinks
See also:

Parameter number whose value will be written to a communications device data table.

316 Data Out D1- Link D Word 1
317 Data Out D2 - Link D Word 2

Range: 0 to 387 [1]
Default: 316 = 33
317 = 218
Access: 1 **Path:** Communication>Datalinks
See also:

Parameter number whose value will be written to a communications device data table.

320 Anlg In Config



Range: See figure 9.31
Default: See figure 9.31
Access: 0 **Path:** Inputs & Outputs>Analog Inputs
See also: 322, 323, 325, 326

Selects the type of input signal being used for analog input 1 and 2.

Analog Inputs - For Frame 4 Drives

The Combined I/O Board contains no component hardware for user-configurable analog inputs, although connector positions, designated A14, are allocated for 4 analog inputs.

The inverter analog input parameters (320-327) have no effect on the operation of the drive, and parameter values should be changed so that the analog inputs are used.

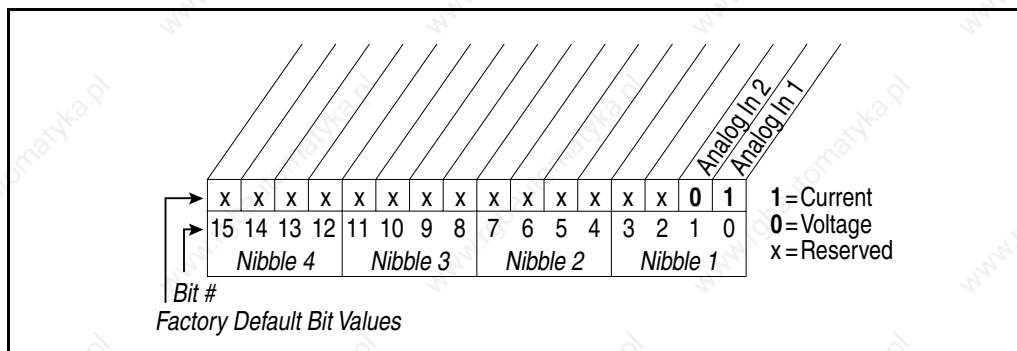

Figure 9.31 – Anlg In Config (320)

For frame 4 drives only (firmware version 2.x), the actual modes of the analog inputs depend on the value of this parameter and on the capabilities of the analog input hardware on the I/O board. The units (V or mA) displayed for the “Analog In Hi” and “Analog In Lo” parameters are an accurate indication of the actual mode of the corresponding analog input.

321 Anlg In Sqr Root

Range: See figure 9.32
Default: See figure 9.32
Access: 1 **Path:** Inputs & Outputs>Analog Inputs
See also: 322, 323, 324, 325, 326, 327

Enables/disables the square root function for each analog input.

This function should be enabled if the input signal varies with the square of the quantity (i.e., drive speed) being monitored. The square root function is scaled such that the input range is the same as the output range. For example, if the input is set up as a unipolar voltage input, then the input and output ranges of the square root function will be 0 to 10 volts.

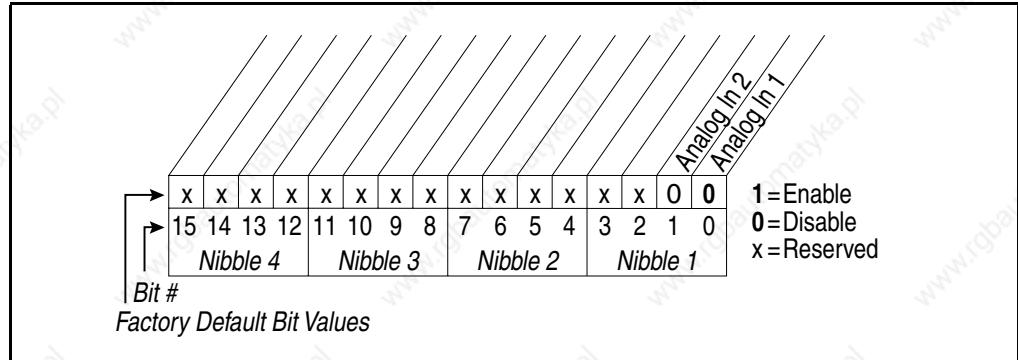

Figure 9.32 – Anlg in Sqr Root (321)

322 Analog In 1 Hi

Range: 4.000 to 20.000 mA [0.001 mA]
 -/+10.000 V [0.1 V]
 0.0 to 10.000 V [0.1 V]

Default: 20.000 mA

Access: 0 **Path:** Inputs & Outputs>Analog Inputs

See also: 91, 92, 320

The drive scales the value read from the analog input and converts it to units usable for the application. The user controls the scaling by setting parameters that associate a low and high point in the input range with a low and high point in the target range.

Analog In 1 Hi sets the highest input value to the analog input 1 scaling block.

Analog Input Scaling Example

Assume:
 Speed Ref A Sel = Analog In 1
 Minimum Freq = 0 Hz
 Maximum Freq = 60 Hz
 Analog In 1 Lo = 0.0 V
 Analog In 1 Hi = 10.0 V

This is the default setting, where minimum input (0 V) represents Minimum Speed and maximum input (10 V) represents Maximum Speed.

323 Analog In 1 Lo

Range: 4.000 to 20.000 mA [0.001 mA]
 -/+10.000 V [0.1 V]
 0.0 to 10.000 V [0.1 V]

Default: 4 mA

Access: 0 **Path:** Inputs & Outputs>Analog Inputs

See also: 91, 92, 320

Sets the lowest input value to the analog input 1 scaling block. Refer to Analog In 1 Hi (322) for more information and a scaling example.

324 Analog In 1 Loss

Range: 0 = Disabled
1 = Fault
2 = Hold Input (use last frequency command)
3 = Set Input Lo (use Minimum Speed as frequency command)
4 = Set Input Hi (use Maximum Speed as frequency command)
5 = Goto Preset1 (use Preset 1 as frequency command)
6 = Hold OutFreq (maintain last output frequency)

Default: 0 = Disabled

Access: 1 **Path:** Inputs & Outputs>Analog Inputs

See also: 91, 92, 320

Selects drive response when an analog signal loss is detected. (1.0 V = signal loss, 1.5 V = end of signal loss; 2.0 mA = signal loss, 3.80 mA = end of signal loss.)

One of the selections (1 = Fault) stops the drive on signal loss. All other choices make it possible for the input signal to return to a usable level while the drive is still running.



ATTENTION: Setting parameter 324 to a value greater than 1 allows the input signal to return to a usable level while the drive is running. If a lost analog signal is restored while the drive is running, the drive will ramp to the restored reference level at the rate specified in Accel Time 1 (140), Accel Time 2 (141), Decel Time 1 (142), and Decel Time 2 (143). Be aware that an abrupt speed change may occur depending upon the new reference level and the rate specified in these parameters. Failure to observe this precaution could result in bodily injury.

Important: Note that there is no signal loss detection while the input is in bipolar voltage mode.

325 Analog In 2 Hi

Range: 4.000 to 20.000 mA [0.001 mA]
-/+10.000 V [0.1 V]
0.0 to 10.000 V [0.1 V]

Default: 10 V

Access: 0 **Path:** Inputs & Outputs>Analog Inputs

See also: 91, 92, 320, 326, 327

Sets the highest 10 value to the analog input 2 scaling block.

326 Analog In 2 Lo

Range: 4.000 to 20.000 mA [0.001 mA]
-/+10.000 V [0.1 V]
0.0 to 10.000 V [0.1 V]

Default: 0.000 V

Access: 0 **Path:** Inputs & Outputs>Analog Inputs

See also: 91, 92, 320, 325, 327

Sets the lowest input value to the analog input 2 scaling block.

327 Analog In 2 Loss

Range: 0 = Disabled
 1 = Fault
 2 = Hold Input (use last frequency command)
 3 = Set Input Lo (use Minimum Speed as frequency command)
 4 = Set Input Hi (use Maximum Speed as frequency command)
 5 = Goto Preset1 (use Preset1 as frequency command)
 6 = Hold OutFreq (maintain last output frequency)

Default: 0 = Disabled

Access: 1 **Path:** Inputs & Outputs>Analog Inputs

See also: 91, 92, 320, 325, 326

Selects drive action when an analog signal loss is detected. (1.0 V = signal loss, 1.5 V = end of signal loss; 2.0 mA = signal loss, 3.0 mA = end of signal loss.)

One of the selections (1 = Fault) stops the drive on signal loss. All other choices make it possible for the input signal to return to a usable level while the drive is still running.



ATTENTION: Setting parameter 327 to a value greater than 1 allows the input signal to return to a usable level while the drive is running. If a lost analog signal is restored while the drive is running, the drive will ramp to the restored reference level at the rate specified in Accel Time 1 (140), Accel Time 2 (141), Decel Time 1 (142), and Decel Time 2 (143). Be aware that an abrupt speed change may occur depending upon the new reference level and the rate specified in these parameters. Failure to observe this precaution could result in bodily injury.

Important: Note that there is no signal loss detection while the input is in bipolar voltage mode.

340 Analog Out Config

Range: See figure 9.33

Default: 1

Access: 1 **Path:** Inputs & Outputs>Analog Outputs

See also:

Selects the mode for analog outputs.

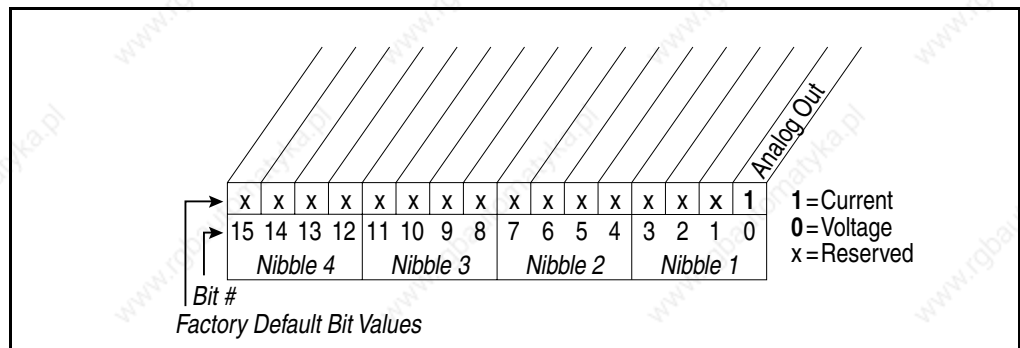

Figure 9.33 – Analog Out Config

For frame 4 drives only (firmware versions 2.x), the actual modes of the analog outputs depend on the value of this parameter and on the capabilities of the analog output hardware on the I/O board. The units (V or mA) displayed for the “Analog Out Hi” and “Analog Out Lo” parameters are an accurate indication of the actual mode of the analog output. The output can produce a voltage between 0 VDC and 10 VDC. Although the inverter Anlg Out Config parameter (340) supports the ability to switch the analog output between the voltage mode and current mode, current mode is not actually supported on this I/O Board, and changing the value in the Anlg Out Config parameter (340) will have no effect on the operation of the drive.

341 Anlg Out Absolut

Range: See figure 9.34
Default: See figure 9.34
Access: 1 **Path:** Inputs & Outputs>Analog Outputs
See also: 342

Selects whether the signed value or absolute value of a parameter is used before being scaled to drive the analog output.

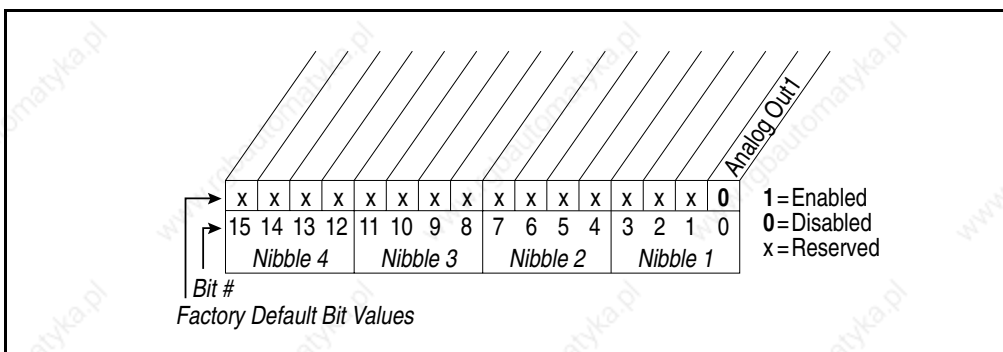

Figure 9.34 – Anlg Out Absolute (341)

342 Analog Out1 Sel

Range: 0 = Output Freq
 1 = Command Freq
 2 = Output Amps
 3 = Torque Amps
 4 = Flux Amps
 5 = Output Power
 6 = Output Volts
 7 = DC Bus Volts
 8 = PI Reference
 9 = PI Feedback
 10 = PI Error
 11 = PI Output
 12 = %Motor OL
 13 = %Drive OL
 14 = Application

Default: 14 = Application

Access: 0 **Path:** Inputs & Outputs>Analog Outputs

See also: 1 - 7, 12, 135 - 138, 219, 220

Selects the source of the value that drives the analog output.

343 Analog Out1 Hi

Range:	4.000 to 20.000 mA [0.001 mA]	
	-/+10.000 V [0.1 V]	
	0.0 to 10.000 V [0.1 V]	
Default:	20.0 mA	
Access:	0	Path: Inputs & Outputs>Analog Outputs
See also:	31, 342	

Sets the analog output value when the source value is at maximum.

Scaling the Analog Output

The user defines the scaling for the analog output by entering analog output voltages into Analog Out1 Lo and Analog Out1 Hi. These two output voltages correspond to the bottom and top of the possible range covered by the quantity being output. The output voltage will vary linearly with the quantity being output. The analog output voltage will not go outside the limits defined by Analog Out1 Lo and Analog Out 1 Hi. See table 9.3.

Table 9.3 – Analog Output Scaling

Options		Analog Out1 Value Corresponds to:		Analog Out 1 Hi (343) Value Corresponds to:
		Analog Out Absolut (341) = Disabled	Analog Out Absolut (341) = Enabled	
0	Output Freq	–[Maximum Freq]	0 Hz	+ [Maximum Freq]
1	Commanded Freq	–[Maximum Speed]	0 Hz	+ [Maximum Speed]
2	Output Amps	0 Amps	0 Amps	200% Rated
3	Torque Amps	–200% Rated	0 Amps	200% Rated
4	Flux Amps	0 Amps	0 Amps	200% Rated
5	Output Power	0 kW	0 kW	200% Rated
6	Output Volts	0 Volts	0 Volts	120% Rated
7	DC Bus Volts	0 Volts	0 Volts	200% Rated
8	PI Reference	–100%	0%	100%
9	PI Feedback	–100%	0%	100%
10	PI Error	–100%	0%	100%
11	PI Output	–100%	0%	100%
12	%Motor OL	0%	0%	100%
13	%Drive OL	0%	0%	100%
14	Application	4.000	4.000	20.000

If Analog Out1 Sel (342) is set to “Application” (14), and the drive is a frame 3 drive (firmware version 1.x), then the source of the analog output value is the value in Appl Analog Out (31), and the values entered in that parameter can range from 4.000 mA (resulting in an analog output level corresponding to Analog Out1 Lo) to 20.000 mA (resulting in an analog output level corresponding to Analog Out1 Hi).

If Analog Out1 Sel (342) is set to “Application” (14), and the drive is a frame 4 drive (firmware version 2.x), then the value entered in Appl Analog Out (31) is output directly on the analog output, irrespective of the values of Analog Out1 Hi (343) and Analog Out1 Lo (344).

344 Analog Out1 Lo

Range: 4.000 to 20.000 mA [0.001 mA]
-/+10.000 V [0.1 V]
0.0 to 10.000 V [0.1 V]]
Default: 4.0 mA
Access: 0 **Path:** Inputs & Outputs>Analog Outputs
See also: 31, 342, 343

Sets the analog output value when the source value is at minimum.

Refer to Analog Out1 Hi (343) for more information.

If Analog Out1 Sel (342) is set to “Application” (14), and the drive is a frame 4 drive (firmware version 2.x), then the value entered in Appl Analog Out (31) is output directly on the analog output, irrespective of the values of Analog Out1 Hi (343) and Analog Out1 Lo (344).

344 Analog Out1 Lo

Range: 4.000 to 20.000 mA [0.001 mA]
-/+10.000 V [0.1 V]
0.0 to 10.000 V [0.1 V]]
Default: 4.0 mA
Access: 0 **Path:** Inputs & Outputs>Analog Outputs
See also: 31, 342, 343

Sets the analog output value when the source value is at minimum.

Refer to Analog Out1 Hi (343) for more information.

For frame 3 drives (firmware version 1.x), this parameter is only usable if an optional Standard I/O board is present.

345 Inv IGBT Tmp Top

Range: -3276.8 to 3276.7 Degrees C
Default: Read Only
Access: 1 **Path:** Inputs & Outputs>Temperature etc
See also: 346, 347, 348

Displays the measured temperature of the top inverter IGBT power module in degrees C.

This parameter is only present on frame 4 drives. All such drives should have firmware version numbers in the 2.x series.

346 Inv IGBT Tmp Up

Range: -3276.8 to 3276.7 Degrees C
Default: Read Only
Access: 1 **Path:** Inputs & Outputs>Temperature etc
See also: 345, 347, 348

Displays the measured temperature of the upper inverter IGBT power module in degrees C.

This parameter is only present on frame 4 drives. All such drives should have firmware version numbers in the 2.x series.

347 Inv IGBT Tmp Low

Range: -3276.8 to 3276.7 Degrees C
Default: Read Only
Access: 1 **Path:** Inputs & Outputs>Temperature etc
See also: 345, 346, 348

Displays the measured temperature of the lower inverter IGBT power module in degrees C.

This parameter is only present on frame 4 drives. All such drives should have firmware version numbers in the 2.x series.

348 Inv IGBT Tmp Bot

Range: -3276.8 to 3276.7 Degrees C
Default: Read Only
Access: 1 **Path:** Inputs & Outputs>Temperature etc
See also: 345, 346, 347

Displays the measured temperature of the bottom inverter IGBT power module in degrees C.

This parameter is only present on frame 4 drives. All such drives should have firmware version numbers in the 2.x series.

349 Inv Coldplt Tmp

Range: -3276.8 to 3276.7 Degrees C
Default: Read Only
Access: 1 **Path:** Inputs & Outputs>Temperature etc
See also:

Displays the measured inverter coldplate temperature in degrees C. This parameter is only usable if a coldplate temperature sensor is installed in the drive.

This parameter is only present on frame 4 drives. All such drives should have firmware version numbers in the 2.x series.

350 Inv Ambient Tmp

Range: -3276.8 to 3276.7 Degrees C

Default: Read Only

Access: 1 **Path:** Inputs & Outputs>Temperature etc

See also:

Displays the measured ambient temperature of the drive in degrees C.

This parameter is only present on frame 4 drives. All such drives should have firmware version numbers in the 2.x series.

351 Inv PS Tmp

Range: -3276.8 to 3276.7 Degrees C

Default: Read Only

Access: 1 **Path:** Inputs & Outputs>Temperature etc

See also:

Displays the measured drive power supply temperature in degrees C.

This parameter is only present on frame 4 drives. All such drives should have firmware version numbers in the 2.x series.

352 Inv PS +12

Range: -3276.8V to 3276.7V Degrees C

Default: Read Only

Access: 1 **Path:** Inputs & Outputs>Temperature etc

See also:

Displays the measured voltage of the +12V power supply.

This parameter is only present on frame 4 drives. All such drives should have firmware version numbers in the 2.x series.

353 Inv PS -12V

Range: -3276.8V to 3276.7V Degrees C

Default: Read Only

Access: 1 **Path:** Inputs & Outputs>Temperature etc

See also:

Displays the measured voltage of the -12V power supply.

This parameter is only present on frame 4 drives. All such drives should have firmware version numbers in the 2.x series.

354 Inv I/O ID V

Range: -3276.8V to 3276.7V Degrees C

Default: Read Only

Access: 1 **Path:** Inputs & Outputs>Temperature etc

See also:

Displays the measured voltage that identifies which type of IO board is installed.

This parameter is only present on frame 4 drives. All such drives should have firmware version numbers in the 2.x series.

- 361 Digital In1 Sel
- 362 Digital In2 Sel
- 363 Digital In3 Sel
- 364 Digital In4 Sel
- 365 Digital In5 Sel
- 366 Digital In6 Sel



Range:	<ul style="list-style-type: none"> 0 = Not Used 1 = Enable 2 = Clear Faults¹ 3 = Aux Fault 4 = Stop - CF² 5 = Start 6 = Fwd/Reverse² 7 = Run³ 8 = Run Forward³ 9 = Run Reverse³ 10 = Jog 11 = Jog Forward 12 = Jog Reverse 13 = Stop Mode B 14 = Bus Reg Md B 15 = Speed Sel 1⁴ 16 = Speed Sel 2⁴ 17 = Speed Sel 3⁴ 18 = Auto/Manual 19 = Local 20 = Acc2 & Dec2 21 = Accel 2 22 = Decel 2 23 = MOP Inc 24 = MOP Dec 25 = Exc Link 26 = PI Enable 27 = PI Hold 28 = PI Reset 29 = Pwr Loss Lvl 30 = Precharge En
Default:	See table 9.5
Access:	361-366 = 0 Path: Inputs & Outputs>Digital Inputs
See also:	96, 100, 124, 140, 156, 162, 194, 380

¹When Digital In"x" Sel is set to option 2 (Clear Faults), the stop key cannot be used to clear a fault condition.

²Typical 3-Wire Inputs. These require that only 3-wire functions are chosen. Including 2-wire selections will cause a type 2 alarm.

³Typical 2-Wire Inputs. These require that only 2-wire functions are chosen. Including 3-wire selections will cause a type 2 alarm.

⁴To access Preset Speed 1, set Speed Ref A Sel to Preset Speed 1. See table 9.4

Table 9.4 – Speed Select Inputs

Speed Select Inputs			Reference Source
3	2	1	
0	0	0	Speed Ref A Sel
0	0	1	Preset Speed 1
0	1	0	Preset Speed 2
0	1	1	Preset Speed 3
1	0	0	Preset Speed 4
1	0	1	Preset Speed 5
1	1	0	Preset Speed 6
1	1	1	Preset Speed 7

Assigns an input function to the drive's digital inputs. Note that digital inputs Run, Jog, Clear-Faults, and Direction control functions are operational only when the mask parameters are set for these functions.

Table 9.5 – Default Values for Parameters 361-366

Parameter No.	Default Value
361	0 = Unused
362	0 = Unused
363	0 = Unused
364	0 = Unused
365	0 = Unused
366	0 = Unused

The input functions are:

1 = Enable: If the input is closed, the drive can run (start permissive). If the input is open, the drive will not start.

If the drive is already running when this input is opened, the drive will coast and indicate "not enabled" on the OIM (if present). This is not considered a fault condition, and no fault will be generated.

If multiple enable inputs are configured, the drive will not run if any of them are open.

2 = Clear Faults: This function allows an external device to reset drive faults through the terminal block if Logic Source Sel (89) is set to Terminal Blk or All Ports. An open-to-closed transition on this input will reset the current fault (if any).

If this input is configured at the same time as Stop-Clear Faults, then only the Clear Faults input can actually cause faults to be reset.

3 = Aux Fault: If the function loss input is open, a fault is generated. The function loss input is active at all times regardless of the selected logic control source.

Important: The function loss input is not intended for a fast output power kill. The drive will not fault until the software detects the change of state of this input. If this input function is not configured, the fault will not occur.

4 = Stop - CF (Stop - Clear Faults): An open input will always assert a stop command. While the stop is asserted, the drive ready status will be off. A closed input will allow the drive to start. An open-to-closed transition is interpreted as a clear faults request. The drive will clear any existing faults.

If Start is configured, then Stop-Clear Faults must also be configured to prevent a digital input configuration alarm condition. Stop-Clear Faults is optional in all other circumstances.

5 = Start: An open-to-closed transition generates a run command if the terminal block is the control source.

If Start is configured, then Stop-Clear Faults must also be configured to prevent a digital input configuration alarm condition.

6 = Fwd/Reverse (Forward/Reverse): An open input sets the direction to forward if the terminal block is the control source. A closed input sets the direction to reverse. If the state of the input changes and the drive is running or jogging, the drive will change direction.

If the Fwd/Rev input function is assigned to more than one physical digital input at a time, a digital input configuration alarm will be asserted.

7 = Run: An open-to-closed transition on this input generates a a run command if the terminal block is the control source. If the input is open, the drive will stop.

The purpose of this input function is to allow a 2-wire start while the direction is being controlled by some other function.

8 and 9 = Run Forward and Run Reverse: If the terminal block is the control source, an open-to-closed transition on one or both inputs while the drive is stopped will cause the drive to run unless the Stop - Clear Faults input function is configured and open.

If one or both of these input functions are assigned to more than one physical digital input at a time, a digital input configuration alarm will be asserted.

10 = Jog: An open-to-closed transition on this input while the drive is stopped causes the drive to start (jog) in the current direction. When the input opens while the drive is running (jogging), the drive will stop.



ATTENTION: If a normal drive start command is received while the drive is jogging, the drive will switch from jog mode to run mode. The drive will not stop, but may change speed and/or change direction. Failure to observe this precaution could result in severe bodily injury or loss of life.

The drive will not jog while running or while the Stop - Clear Faults input is open. Start has precedence over jog.

11 and 12 = Jog Forward and Jog Reverse: An open-to-closed transition on one or both inputs while the drive is stopped will cause the drive to jog unless the Stop - Clear Faults input function is configured and open. Table 9.6 describes the actions taken by the drive in response to various states of these input functions.

Table 9.6 – Drive Response to Jog Forward and Jog Reverse Inputs

Jog Forward	Jog Reverse	Drive Response
Open	Open	Drive will stop if already jogging, but can be started by other means.
Open	Closed	Drive jogs in reverse direction.
Closed	Open	Drive jogs in forward direction.
Closed	Closed	Drive continues to jog in current direction.



ATTENTION: If a normal drive start command is received while the drive is jogging, the drive will switch from jog mode to run mode. The drive will not stop, but may change speed and/or change direction. Failure to observe this precaution could result in severe bodily injury or loss of life.

The drive will not jog while running or while the Stop-Clear Faults input is open. Start has precedence over jog.

If one of these input functions is configured and the other one is not, table 9.6 still applies, but the unconfigured input function should be considered permanently open.

13 = Stop Mode B: This digital input selects between two different drive stop modes.

If the input is open, then Stop Mode A selects which stop mode to use. If the input is closed, the Stop Mode B selects which stop mode to use. If this input function is not configured, then Stop Mode A selects which stop mode to use.

14 = Bus Regulation Mode B: This digital input function selects how the drive will regulate excess voltage on the DC bus.

If the input is open, then Bus Reg Mode A selects which bus regulation mode to use. If the input is closed, then Bus Reg Mode B selects which bus regulation mode to use. If this input function is not configured, then Bus Reg Mode A selects which bus regulation mode to use.

15-17 = Speed Select 1, 2, 3: One, two, or three digital input functions can be used to select the speed reference used by the drive, and they are called the Speed Select input functions. The current open/closed state of all Speed Select input functions combine to select which source is the current speed reference.

There are 7 possible combinations of open/closed states for the three input functions, and thus 7 possible parameters can be selected. The 7 parameters are: Speed Ref A Sel and Preset Speed 2 through Preset Speed 7.

If the Speed Select input functions select Speed Ref A Sel, then the value of that parameter further selects a reference source. There are a large number of possible selections, including all 6 presets.

If the input functions directly select one of the preset speed parameters, then the parameter contains a frequency that is to be used as the reference.

The Speed Select input function configuration process involves assigning the functionality of the three possible Speed Select input functions to physical digital inputs. The three Speed Select inputs functions are called Speed Select 1, Speed Select 2, and Speed Select 3, and they are assigned to physical inputs using the Digital In"x" Sel parameters.

Table 9.6 describes the various reference sources that can be selected using all three of the Speed Select input functions. If any of the three Reference Select input functions are not configured, then the software will still follow the table, but will treat the unconfigured inputs as if they are permanently open.

Table 9.7 – Effect of Speed Select Input State on Selected Reference

Speed Select 3	Speed Select 2	Speed Select 1	Parameter that determines reference:
Open	Open	Open	Speed Ref A Sel
Open	Closed	Open	Preset Speed 2
Open	Closed	Closed	Preset Speed 3
Closed	Open	Open	Preset Speed 4
Closed	Open	Closed	Preset Speed 5
Closed	Closed	Open	Preset Speed 6
Closed	Closed	Closed	Preset Speed 7

18 = Auto/Manual: The Auto/Manual function allows a single control device to assume exclusive control of reference select. The most recent peripheral (OIM or terminal block) that makes a manual reference request will be given control of the reference.

If the Auto/Manual input function is closed, then the drive will use one of the analog inputs (defined by TB Man Ref Sel) as the reference. If an OIM subsequently requests manual control (that is, Auto/Man F-Key is pressed) and then gives control up (presses Auto/Man F-Key again), then the Auto/Manual digital input must be opened and closed again to regain control of the manual reference.

If this input is open, then the terminal block does not request manual control of the reference. If no control device (including the terminal block) is current requesting manual control of the reference, then the drive will use the normal reference selection mechanisms.

20 = Acc2 & Dec2: A single input function is used to select between Accel Time 1/Decel Time 1 and Accel Time 2/Decel Time2.

If the function is open, the drive will use Accel Time 1 as the acceleration rate and Decel Time 1 as the deceleration rate. If the function is closed, the drive will use Accel Time 2 as the acceleration rate and Decel Time 2 as the deceleration rate.

21, 22 = Accel 2, Decel 2: One input function (called Accel 2) selects between Accel Time 1 and Accel Time 2, and another input function (called Decel 2) selects between Decel Time 1 and Decel Time 2. The open state of the function selects Accel Time 1 or Decel Time 1, and the closed state selects Accel Time 2 or Decel Time 2.

23, 24 = MOP Increment, MOP Decrement: The MOP is a reference setpoint (called the MOP Value) that can be incremented and decremented by external devices. These inputs are used to increment and decrement the Motor Operated Potentiometer (MOP) value inside the drive. The MOP value will be retained through a power cycle.

While the MOP Increment input is closed, the MOP value will increase at rate contained in MOP Rate. Units for rate are Hz per second.

While the MOP Decrement input is closed, MOP value will decrease at rate contained in MOP Rate. Units for rate are Hz per second.

If both the MOP Increment and MOP Decrement inputs are closed, the MOP value will stay the same.

In order for the drive to use the MOP value as the current speed reference, either Speed Ref A Sel must be set to MOP.

25 = OIM Control: This input provides a mean to override the logic control source selection and can be used to override control from any port, including the All Ports selection.

An open-to-closed transition of this input sets the control source to the local OIM. If no local OIM is present, the control source is set to the remote OIM. If no OIM is present at all, the drive stops.

When control is set to the OIM, the OIM is granted manual reference (the Man Ref Preload (193) configuration is enforced). Subsequent Auto/Manual commands will toggle the OIM in and out of manual mode. The drive's active or stopped state is not affected unless no OIM is present.

On a closed-to-open transition, manual control is released if active, and the selected auto reference is used. The logic source select override is removed. The edge/level-sense start configuration is imposed (LevelSense Start).

26 = PI Enable: If this input function is closed, the operation of the Process PI loop will be enabled.

If this input function is open, the operation of the Process PI loop will be disabled.

27 = PI Hold: If this input function is closed, the integrator for the Process PI loop will be held at the current value; that is, it will not increase.

If this input function is open, the integrator for the Process PI loop will be allowed to increase.

28 = PI Reset: If this input function is closed, the integrator for the Process PI loop will be reset to 0.

If this input function is open, the integrator for the Process PI loop will integrate normally.

29 = Pwr Loss Lvl: When the DC bus level in the drive falls below a certain level, a "power loss" condition is created in the drive logic. This input allows the user to select between two different "power loss" detection levels dynamically. If the physical input is closed, then the drive will take its power loss level from a parameter. If the physical input is open (de-energized), then the drive will use a power loss level designated by internal drive memory, typically 82% of nominal. If the input function is not configured, then the drive always uses the internal power loss level.

30 = Precharge En: This input function is used to manage disconnection from a common DC bus.

If the physical input is closed, this indicates that the drive is connected to common DC bus and normal precharge handling can occur, and that the drive can run (start permissive). If the physical input is open, this indicates that the drive is disconnected from the common DC bus, and thus the drive should enter the precharge state (precharge relay open) and initiate a coast stop immediately in order to prepare for reconnection to the bus.

If this input function is not configured, then the drive assumes that it is always connected to the DC bus, and no special precharge handling will be done.

Type 2 Alarms

Some digital input programming may cause conflicts that result in a Type 2 alarm. For example, Digital In1 Sel set to 5 (Start) in 3-wire control, and Digital In2 Sel set to 7 (Run) in 2-wire control. Refer to chapter 10 for more information about these alarms.

Dig In Status (116) indicates the current state of the digital inputs.

380 Digital Out1 Sel

Range:	1 = Fault (De-energized = Fault, Energized = No Fault)
	2 = Alarm (De-energized = Inverter Alarm, Energized = No Inverter Alarm)
	3 = Ready
	4 = Run
	5 = Forward Run
	6 = Reverse Run
	7 = Auto Restart
	8 = Powerup Run
	9 = At Speed
	10 = At Freq
	11 = At Current
	12 = At Torque
	13 = At Temp
	14 = At Bus Volts
	15 = At PI Error
	16 = DC Braking
	17 = Curr Limit
	18 = Economize
	19 = Motor Overld
	20 = Power Loss
	21 = Input 1 Link
	22 = Input 2 Link
	23 = Input 3 Link
	24 = Input 4 Link
	25 = Input 5 Link
	26 = Input 6 Link
	27 = Shunt Trip
	28 = Aux Run
Default:	27 = Shunt Trip
Access:	0 Path: Inputs & Outputs>Digital Outputs
See also:	1-4, 12, 48, 53, 137, 147, 157, 184, 218, 381-383, 385, 386

Selects the drive status that will energize an output relay.

For frame 3 drives (firmware version 1.x), if this parameter is set to “Aux Run” (28), then digital output 2 on the AC Line I/O board will be energized whenever the drive is running.

For frame 4 drives (firmware version 2.x), if this parameter is set to “Aux Run’ (28), then the digital output designated DO3 on the combined I/O board will be energized whenever the drive is running.

381 Dig Out1 Level

Range: 0.0 to 819.2 [0.1]
Default: 0.0
Access: 0 **Path:** Inputs & Outputs>Digital Outputs
See also: 380

Sets the relay activation level for options 10-15 in Digital Out“x” Sel. Units are assumed to match the above selection (i.e., At Freq = Hz, At Torque = Amps).

382 Dig Out1 OnTime

Range: 0.00 to 600.00 sec [0.01 sec]
Default: 0.00 sec
Access: 1 **Path:** Inputs & Outputs>Digital Outputs
See also: 380

Sets the on delay time for the digital outputs. This is the time between the occurrence of a condition and activation of the relay.

383 Dig Out1 OffTime

Range: 0.00 to 600.00 sec [0.01 sec]
Default: 0.00 sec
Access: 1 **Path:** Inputs & Outputs>Digital Outputs
See also: 380

Sets the off delay time for the digital outputs. This is the time between the disappearance of a condition and de-activation of the relay.

384 Digital Out2 Sel

Range:	1 = Fault (De-energized = Fault, Energized = No Fault) 2 = Alarm (De-energized = Inverter Alarm, Energized = No Inverter Alarm) 3 = Ready 4 = Run 5 = Forward Run 6 = Reverse Run 7 = Auto Restart 8 = Powerup Run 9 = At Speed 10 = At Freq 11 = At Current 12 = At Torque 13 = At Temp 14 = At Bus Volts 15 = At PI Error 16 = DC Braking 17 = Curr Limit 18 = Economize 19 = Motor Overld 20 = Power Loss 21 = Input 1 Link 22 = Input 2 Link 23 = Input 3 Link 24 = Input 4 Link 25 = Input 5 Link 26 = Input 6 Link 27 = Shunt Trip 28 = Aux Run
Default:	4 = Run
Access:	0 Path: Inputs & Output>Digital Outputs
See also:	1 - 4, 12, 48, 53, 137, 147, 157, 184, 218, 381-383, 385, 386

Selects the drive status that will energize an output relay.

For frame 3 drives (firmware version 1.x), if this parameter is set to “Aux Run” (28), then digital output 2 on the AC Line I/O board will be energized whenever the drive is running.

For frame 4 drives (firmware version 2.x), if this parameter is set to “Aux Run” (28), then the digital output designated DO3 on the combined I/O board will be energized whenever the drive is running.

385 Dig Out2 Level

Range:	0.0 to 819.2 [0.1]
Default:	0.0
Access:	0 Path: Inputs & Output>Digital Outputs
See also:	384

Sets the relay activation level for options 10-15 in Digital Out“x” Sel. Units are assumed to match the above selection (i.e., At Freq = Hz, At Torque = Amps).

386 Dig Out2 OnTime

Range: 0.00 to 600.00 sec [0.01 sec]
Default: 0.00 sec
Access: 1 **Path:** Inputs & Output>Digital Outputs
See also: 384

Sets the on delay time for the digital outputs. This is the time between the occurrence of a condition and activation of the relay.

387 Dig Out2 OffTime

Range: 0.00 to 600.00 sec [0.01 sec]
Default: 0.00 sec
Access: 1 **Path:** Inputs & Output>Digital Outputs
See also: 384

Sets the off delay time for the digital outputs. This is the time between the disappearance of a condition and de-activation of the relay.

9.2 Rectifier Parameters

1 Line Frequency

Range: 0.0 to 63.0 Hz [0.1 Hz]
Default: Read Only
Access: 0 **Path:** Monitor>Metering
See also:

The input line frequency is displayed as x.x Hz.

2 Input Current R

Range: 0.0 to 3276.7 A [0.1 A]
Default: Read Only
Access: 0 **Path:** Monitor>Metering
See also:

The input phase current I_r is displayed as x.x A.

3 Input Current S

Range: 0.0 to 3276.7 A [0.1 A]
Default: Read Only
Access: 0 **Path:** Monitor>Metering
See also:

The input phase current I_s is displayed as x.x A.

4 Input Current T

Range: 0.0 to 3276.7 A [0.1 A]
Default: Read Only
Access: 0 **Path:** Monitor>Metering
See also:

The input phase current I_t is displayed as x.x A.

5 Active Current

Range: ± 3276.7 A [0.1 A]
Default: Read Only
Access: 0 **Path:** Monitor>Metering
See also:

The active current is displayed as $\pm x.x$ A. Motoring current is positive and generating current is negative.

6 Reactive Current

Range: 0.0 to 3276.7 A [0.1 A]
Default: Read Only
Access: 0 **Path:** Monitor>Metering
See also:

The reactive current is displayed as $x.x$ A. This value should always be near 0.

7 Input Voltage RS

Range: 0.0 to 3276.7 V [0.1 V]
Default: Read Only
Access: 0 **Path:** Monitor>Metering
See also:

The phase-to-phase input voltage V_{rs} is displayed as $x.x$ V.

8 Input Voltage ST

Range: 0.0 to 3276.7 V [0.1 V]
Default: Read Only
Access: 0 **Path:** Monitor>Metering
See also:

The phase-to-phase input voltage V_{st} is displayed as $x.x$ V.

9 Input Voltage TR

Range: 0.0 to 3276.7 V [0.1 V]
Default: Read Only
Access: 0 **Path:** Monitor>Metering
See also:

The phase-to-phase input voltage V_{tr} is displayed as $x.x$ V.

10 DC Bus Voltage

Range: 0.0 to 3276.7 VDC [0.1 VDC]
Default: Read Only
Access: 0 **Path:** Monitor>Metering
See also:

The DC bus voltage is displayed as x.x V.

11 Active Voltage

Range: 0.0 to 3276.7 V [0.1 V]
Default: Read Only
Access: 0 **Path:** Monitor>Metering
See also:

The commanded active voltage is displayed as x.x V.

12 Reactive Voltage

Range: 0.0 to 3276.7 V [0.1 V]
Default: Read Only
Access: 0 **Path:** Monitor>Metering
See also:

The commanded reactive voltage is displayed as x.x V.

13 Input kW

Range: ± 2400.0 kW [0.1 kW]
Default: Read Only
Access: 0 **Path:** Monitor>Metering
See also:

The input power is displayed as x.x kW. Motoring power is positive and generating power is negative.

14 Input Pwr Factor

Range: 0.00 to 2.00 [0.01]
Default: Read Only
Access: 0 **Path:** Monitor>Metering
See also:

The input power factor is displayed as 1.00 for unity. Values greater than 1 indicate leading power factor.

15 Motoring kWh

Range: 0.0 to 429496729.5 kWh [0.1 kWh]
Default: Read Only
Access: 0 **Path:** Monitor>Metering
See also:

The elapsed kWh consumed is displayed as x.x kWh. This parameter is reset through the Reset Meters (200) parameter.

16 Regen kWh

Range: 0.0 to 429496729.5 kWh [0.1 kWh]
Default: Read Only
Access: 0 **Path:** Monitor>Metering
See also:

The elapsed kWh consumed is displayed as x.x kWh. This parameter is reset through the Reset Meters (200) parameter.

17 Elapsed Run Time

Range: 0.0 to 429496729.5 hour [0.1 hour]
Default: Read Only
Access: 0 **Path:** Monitor>Metering
See also:

The elapsed run time is displayed as x.x hours. This parameter is reset through the Reset Meters (200) parameter.

18 Rctfr Base Temp

Range: -20.0 to 120.0 °C [0.1 °C]
Default: Read Only
Access: 0 **Path:** Monitor>Metering
See also:

The measured rectifier sink temperature is displayed as x.x °C.

19 Rctfr IGBT Temp

Range: -20.0 to 120.0 °C [0.1 °C]
Default: Read Only
Access: 0 **Path:** Monitor>Metering
See also:

The calculated rectifier IGBT temperature is displayed as x.x °C.

20 Rctfr IT Overld

Range: 0.0 to 100.0% [0.1%]
Default: Read Only
Access: 0 **Path:** Monitor>Metering
See also:

The rectifier IT overload calculation is displayed as x.x% where the value of 100.0 is the point where a fault is generated.

21 Rctfr I²T Overld

Range: 0.0 to 100.0% [0.1%]
Default: Read Only
Access: 0 **Path:** Monitor>Metering
See also:

The rectifier I²T overload is displayed as x.x% where the value of 100.0 is the point where a fault is generated.

22 Line I Imbalance

Range: 0.0 to 100.0% [0.1%]
Default: Read Only
Access: 0 **Path:** Monitor>Metering
See also:

The imbalance in input phase current is displayed as x.x%.

23 Line V Imbalance

Range: 0.0 to 100.0% [0.1%]
Default: Read Only
Access: 0 **Path:** Monitor>Metering
See also:

The imbalance in input phase voltage is displayed as x.x%.

26 Rated kW

Range: 0.00 to 3000.0 kW [x.xx kW]
Default: Read Only
Access: 0 **Path:** Monitor>Drive Data
See also:

The rectifier rated kW is displayed as x.xx kW.

27 Rated Volts

Range 0.0 to 6553.5 V [0.1 V]
Default: Read Only
Access: 0 **Path:** Monitor>Drive Data
See also:

The rectifier rated input voltage is displayed as x.x V.

28 Rated Amps

Range: 0.0 to 3553.5 A [0.1 A]
Default: Read Only
Access: 0 **Path:** Monitor>Drive Data
See also:

The rectifier rated input current is displayed as x.x A.

29 Control SW Ver

Range: x.xxx
Default: Read Only
Access: 0 **Path:** Monitor>Drive Data
See also:

The software version number is displayed as x.xxx.

60 V Imbalance Lmt

Range: **Path:** 0.0 to 20.0% [0.1%]
Default: 10.0
Access: 0 **Path:** Configuration>AC Line
See also:

The allowed level of imbalance in input voltage entered as x.x%.

61 V Imbalance Time

Range: 1.0 to 10.0 seconds [0.1 seconds]
Default: 1.0
Access: 0 **Path:** Configuration>AC Line
See also:

A fault is generated if Line V Imbalance (23) is greater than V Imbalance Lmt (60) for this amount of time.

62 I Imbalance Lmt

Range: 0.0 to 40.0% [0.1%]
Default: 10.0
Access: 0 **Path:** Configuration>AC Line
See also:

The allowed level of imbalance in input current entered as x.x%.

63 I Imbalance Time

Range: 1.0 to 10.0 seconds [0.1 seconds]
Default: 10.0
Access: 0 **Path:** Configuration>AC Line
See also:

A fault is generated if Line I Imbalance (22) is greater than I Imbalance Limit (62) for this amount of time.

64 Ride Through Ena

Range: 0 = Disabled
1 = Enabled
Default: 0 = Disabled
Access: 0 **Path:** Configuration>AC Line
See also:

Defines whether or not the ride-through time will be used.

65 Ride Through Sec

Range: 0.00 to 60.00 seconds [x.xx seconds]
Default: 1.00
Access: 0 **Path:** Configuration>AC Line
See also:

Defines the allowed power dip time that will not cause a line lost fault.

Setting a value of 0 will generate a fault on a loss of a single line cycle. Setting a value of 0.10 allows line synchronization to be lost for 100 msec before a fault is generated.

A fault is also generated if the bus voltage drops below the power loss threshold before the ride-through time has elapsed.

100 Rectifier Contrl

Range: See figures 10.36 and 10.37
Default: See figure 10.36 and 10.37
Access: 0 **Path:** Dynamic Control>Control and Status
See also:

For frame 3 drives (firmware version 1.x) only:

The commanded state of the rectifier. Written to by inverter through use of a datalink.

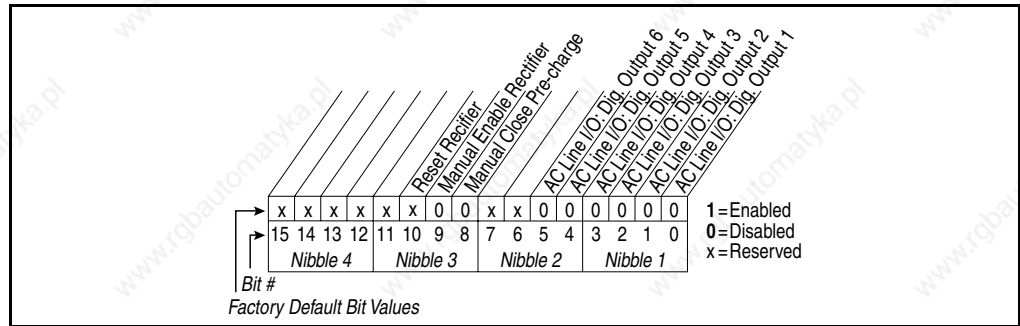

Figure 9.35 – Rectifier Control Word (Rectifier 100) Frame 3

For frame 4 drives (firmware version 2.x) only:

The commanded state of the rectifier.

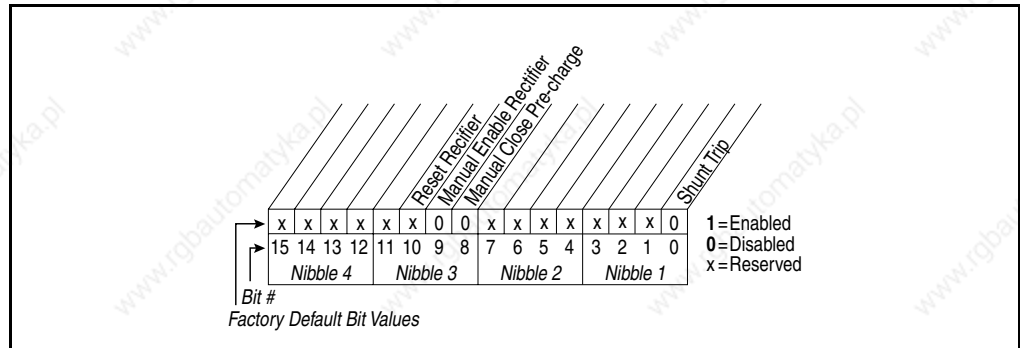

Figure 9.36 – Rectifier Control Word (Rectifier 100) Frame 4

101 Rectifier Status

Range:	See figure 10.34
Default:	See figure 10.34
Access:	0 Path: Dynamic Control>Control and Status
See also:	

The actual state of the rectifier. Written to inverter through use of a datalink.

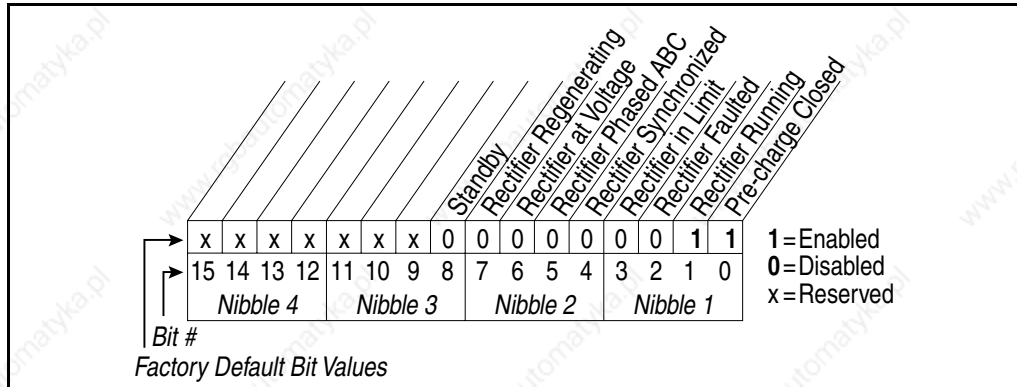

Figure 9.37 – Rectifier Status Word (Rectifier 101)

102 Vdc Optimize

Range:	0 = Disabled 1 = Enabled
Default:	0 = Disabled
Access:	0 Dynamic Control>Bus Voltage
See also:	

Selects whether Vdc optimization is enabled or disabled.

103 Vdc Reference

Range:	400.0 to 750.0 [x.x V]
Default:	700.0
Access:	0 Dynamic Control>Bus Voltage
See also:	

The reference to the voltage major loop.

104 Vdc Command

Range: 400.0 to 750.0 [x.x V]
Default: 700.0
Access: 0 **Path:** Dynamic Control>Bus Voltage
See also:

Displays the commanded DC bus voltage.

This will be different than Vdc Reference (103) only when Vdc Optimize (102) is enabled or the rectifier is not enabled.

105 Current Limit

Range: Rectifier Rated Amps/4 to 150% of Rectifier Rated Amps [x.x A]
Default: 150% of Rectifier Rated Amps
Access: 0 **Path:** Dynamic Control>Load Limits
See also:

The maximum current the rectifier will produce expressed as x.x A.

106 Input Load Amps

Range: Rectifier Rated Amps/4 to 150% of Rectifier Rated Amps [0.1 A]
Default: 150% of Rectifier Rated Amps
Access: 0 **Path:** Dynamic Control>Load Limits
See also:

Sets the 100% current level for the rectifier. I²T diagnostic.

107 Max Motor Volts

Range: 60.0 to 480.0 [0.1 V]
Default: 480.0
Access: 0 **Path:** Dynamic Control>Load Limits
See also:

The maximum required motor voltage.

This value is used in calculating the optimal DC bus voltage to command.

Max Motor Volts (107) should have the same value as inverter parameter Maximum Voltage (54).

108 Max Motor Freq

Range: 5.0 to 400.0 [0.1 Hz]
Default: 100.0
Access: 0 **Path:** Dynamic Control>Load Limits
See also:

The maximum frequency that can be commanded by the inverter.

This value is used in calculating the optimal DC bus voltage to command.

Max Motor Freq (108) should have the same value as inverter parameter Maximum Freq (55).

109 Base Motor Freq

Range: 5.0 to 400.0 [0.1 Hz]
Default: 60.0
Access: 0 **Path:** Dynamic Control>Load Limits
See also:

The base frequency for the motor.

This value is used in calculating the optimal DC bus voltage to command.

Base Motor Freq (109) should have the same value as inverter parameter Motor NP Hertz (43).

110 VML Ki

Range: 0 to 65535
Default: Based on drive size
Access: 0 **Path:** Dynamic Control>Regulator Tuning
See also:

Voltage Major Loop integral gain.

111 VML Kp

Range: 0 to 65535
Default: Based on drive size
Access: 0 **Path:** Dynamic Control>Regulator Tuning
See also:

Voltage Major Loop proportional gain.

112 CML Ki

Range: 0 to 65535
Default: Based on drive size
Access: 0 **Path:** Dynamic Control>Regulator Tuning
See also:

Current Minor Loop integral gain.

113 CML Kp

Range: 0 to 65535
Default: Based on drive size
Access: 0 **Path:** Dynamic Control>Regulator Tuning
See also:

Current Minor Loop integral gain.

114 VML Reset Level

Range: 10.0 to 300.0 VDC [0.1 VDC]
Default: Based on drive size
Access: 0 **Path:** Dynamic Control>Regulator Tuning
See also:

The threshold for resetting the voltage loop integrator.

120 Cold Plate Temp

Range: -20.0 to 120.0°C [0.1°C]
Default: Read Only
Access: 0 **Path:** Dynamic Control>Cold Plate
See also: 121, 122, 129

The measured cold plate temperature is displayed as x.x °C.

121 Invtr Base Temp

Range: -20.0 to 120.0°C [0.1°C]
Default: Read Only
Access: 0 **Path:** Dynamic Control>Cold Plate
See also: 120, 122, 129

The measured inverter base temperature is displayed as x.x °C.

122 Rctfr Base Temp

Range: -20.0 to 120.0°C [0.1°C]
Default: Read Only
Access: 0 **Path:** Dynamic Control>Cold Plate
See also: 120, 121, 129

The measured rectifier base temperature is displayed as x.x °C.

-
- 123 CPC K1
 - 124 CPC K2
 - 125 CPC K3
 - 126 CPC K4
 - 127 CPC K5
 - 128 CPC K6

Range: 0 to 65535
Default: 0
Access: 0 **Path:** Dynamic Control>Cold Plate
See also:

These parameters are reserved for future use.

129 Ambient Temp

Range: -20.0 to 120.0°C [0.1°C]
Default: Read Only
Access: 0 **Path:** Dynamic Control>Cold Plate
See also: 120, 121, 122

Displays the measured ambient temperature.

150 Input Load Amps

Range: 0.0 to 100.0
Default: Read Only
Access: 0 **Path:** Internal Data>Normalized Amps
See also:

Displays measured average amps normalized to 100.0 for 100% of rectifier rating.

151 Current Limit

Range: 0 to 4096
Default: Read Only
Access: 0 **Path:** Internal Data>Normalized Amps
See also:

Displays the value of the current limit normalized to 4096 for rated current.

152 Life KWH

Range: 0.0 to 429496729.5 kWh
Default: Read Only
Access: 0 **Path:** Internal Data>Total Elapsed
See also:

Displays the kWh accumulated over the life of the product.

153 Life Run Time

Range: 0.0000 to 429496.7295 hours
Default: Read Only
Access: 0 **Path:** Internal Data>Total Elapsed
See also:

Displays the run time accumulated over the life of the product.

154 Life Power Time

Range: 0.0000 to 429496.7295 hours
Default: Read Only
Access: 0 **Path:** Internal Data>Total Elapsed
See also:

Displays the time that power was applied to the drive.

155 Life Power Cycle

Range: 0 to 4294967295
Default: Read Only
Access: 0 **Path:** Internal Data>Total Elapsed
See also:

Displays the accumulated number of times power was cycled over the life of the product.

156 DPI Error

Range: 0 to 255
Default: Read Only
Access: 0 **Path:** Internal Data>DPI Counters
See also:

Increments when there is a DPI error.

157 CS Msg Rx Cnt

Range: 0 to 65535
Default: Read Only
Access: 0 **Path:** Internal Data>DPI Counters
See also:

Increments when a client/server message is received.

158 CS Msg Tx Cnt

Range: 0 to 65535
Default: Read Only
Access: 0 **Path:** Internal Data>DPI Counters
See also:

Increments when a client/server message is transmitted.

159 CS Timeout Cnt

Range: 0 to 255
Default: Read Only
Access: 0 **Path:** Internal Data>DPI Counters
See also:

Increments when a client/server message times out.

160 CS MSG Bad Cnt

Range: 0 to 255
Default: Read Only
Access: 0 **Path:** Internal Data>DPI Counters
See also:

Increments when a bad client/server request is received.

161 PC MSG Rx Cnt

Range: 0 to 65535
Default: Read Only
Access: 0 **Path:** Internal Data>DPI Counters
See also:

Increments when a producer/consumer message is received.

162 PC MSG Tx Cnt

Range: 0 to 65535
Default: Read Only
Access: 0 **Path:** Internal Data>DPI Counters
See also:

Increments when a producer/consumer message is transmitted.

163 PC Timeout Cnt

Range: 0 to 255
Default: Read Only
Access: 0 **Path:** Internal Data>DPI Counters
See also:

Increments when a producer/consumer message times out.

164 CAN Bus Off Cnt

Range: 0 to 65535
Default: Read Only
Access: 0 **Path:** Internal Data>DPI Counters
See also:

Increments when CAN bus is off.

171 D/A Select (N)**172****173****174**

Range: 0 to 65535
Default: Read Only
Access: 0 **Path:** Internal Data>D/A Output Sel
See also:

Selects signals to map to a D/A test card.

196 Param Access Lvl

Range: 0 = Basic
1 = Advanced
Default: 0
Access: 0 **Path:** Utility>Drive Memory
See also:

197 Reset to Defaults

Range: 0 = Ready
1 = Reset to Defaults
Default: 0
Access: 0 **Path:** Utility>Drive Memory
See also:

Writing a 1 to this parameter resets the rectifier to factory default values.

198 Load Frm Usr Set

Range: 0 to 3
Default: Read Only
Access: 0 **Path:** Utility>Drive Memory
See also:

199 Save to User Set

Range: 0 to 3
Default: Read Only
Access: 0 **Path:** Utility>Drive Memory
See also:

200 Reset Meters

Range: 0 = Ready
1 = KWH
2 = Elapsed Time
Default: 0
Access: 0 **Path:** Utility>Drive Memory
See also:

Writing a 1 to this parameter resets the elapsed data parameters

201 Language

Range: 0 to 10
Default: Read Only
Access: 0 **Path:** Utility>Drive Memory
See also:

203 Drive Checksum

Range: 0 to 65535
Default: Read Only
Access: 0 **Path:** Utility>Drive Memory
See also:

211 Drive Alarm

Range:
Default: Read Only
Access: 0 **Path:** Utility>Status
See also:

Reserved for future alarms.

214 Start Inhibits

Range:
Default: Read Only
Access: 0 **Path:** Utility>Status
See also:

Reserved for inhibit bits.

216 Dig In Status

Range: Bits on/off
Default: Read Only
Access: 0 **Path:** Utility>Status
See also:

Displays status of digital inputs.

217 Dig Out Status

Range: Bits on/off
Default: Read Only
Access: 0 **Path:** Utility>Status
See also:

Displays status of digital outputs.

220 Fault Frequency

Range: -/+ 400.0 Hz [0.1 Hz]
Default: Read Only
Access: 0 **Path:** Utility>Diagnostics
See also:

Displays line frequency fault value.

221 Fault Amps R

Range: 0.0 to 3276.7 A [0.1 A]
Default: Read Only
Access: 0 **Path:** Utility>Diagnostics
See also:

Displays phase R fault current value.

222 Fault Amps S

Range: 0.0 to 3276.7 A [0.1 A]
Default: Read Only
Access: 0 **Path:** Utility>Diagnostics
See also:

Displays phase S fault current value.

223 Fault Amps T

Range: 0.0 to 3276.7 A [0.1 A]
Default: Read Only
Access: 0 **Path:** Utility>Diagnostics
See also:

Displays phase T fault current value.

224 Fault Amps Q

Range: 0.0 to 3276.7 A [0.1 A]
Default: Read Only
Access: 0 **Path:** Utility>Diagnostics
See also:

Displays active fault current value.

225 Fault Amps D

Range: 0.0 to 3276.7 A [0.1 A]
Default: Read Only
Access: 0 **Path:** Utility>Diagnostics
See also:

Displays reactive fault current value.

226 Fault Volts Vdc

Range: 0.0 to 3276.7 VDC [0.1 VDC]
Default: Read Only
Access: 0 **Path:** Utility>Diagnostics
See also:

Displays bus fault voltage value.

227 Fault Volts Q

Range: 0.0 to 3276.7 V [0.1 V]
Default: Read Only
Access: 0 **Path:** Utility>Diagnostics
See also:

Displays active fault voltage value.

228 Fault Volts D

Range: 0.0 to 3276.7 V [0.1 V]
Default: Read Only
Access: 0 **Path:** Utility>Diagnostics
See also:

Displays reactive fault voltage value.

234 Testpoint 1 Sel

Range: 0 to 65535
Default: 499
Access: 0 **Path:** Utility>Diagnostics
See also:

235 Testpoint 1 Data

Range: -/+ 217483646
Default: 0
Access: 0 **Path:** Utility>Diagnostics
See also:

236 Testpoint 2 Sel

Range: 0 to 65535
Default: 499
Access: 0 **Path:** Utility>Diagnostics
See also:

237 Testpoint 2 Data

Range: -/+ 217483646
Default: 0
Access: 0 **Path:** Utility>Diagnostics
See also:

238 Fault Config

Range: Bits on/off
Default: Read Only
Access: 0 **Path:** Utility>Fault Queue
See also:

Reserved for future use.

240 Fault Clear

Range: 0 = Ready
1 = Clear Faults
2 = Clear Flt Queue
Default: Read Only
Access: 0 **Path:** Utility>Fault Queue
See also:

Faults in the rectifier may be cleared, and the fault queue cleared by writing to this parameter.

241 Fault To Invert

Range: 0 to 255
Default: Read Only
Access: 0 **Path:** Utility>Fault Queue
See also:

This value is copied to the inverter through a datalink to transmit rectifier faults to the inverter.

242 Power Up Marker

Range: 0.0000 to 429496.7295
Default: Read Only
Access: 0 **Path:** Utility>Fault Queue
See also:

Elapsed hours since initial drive power up. This value will roll over to 0 after the drive has been powered on for more than the maximum value shown.

243 Fault 1 Code
245 Fault 2 Code
247 Fault 3 Code
249 Fault 4 Code

Range: 0 to 65535
Default: Read Only
Access: 0 **Path:** Utility>Fault Queue
See also:

A code that represents a drive fault. The codes will appear in these parameters in the order they occur. Fault 1 Code = the most recent fault.

244 Fault 1 Time
246 Fault 2 Time
248 Fault 3 Time
250 Fault 4 Time

Range: 0.0000 to 429496.7295
Default: Read Only
Access: 0 **Path:** Monitor>Metering
See also:

The time between initial power up and the occurrence of the associated fault. Can be compared to Power Up Marker for the time from the most recent power up.

Fault x Time - Power Up Marker = the time difference to the most recent power up. A negative value indicates a fault occurred before the most recent power up. A positive value indicates a fault occurred after the most recent power up.

345 Rct IGBT Tmp Top

Range: -3276.8 to 3276.7 Degrees C
Default: Read Only
Access: 1 **Path:** Inputs & Outputs>Temperature etc
See also: 346, 347, 348

Displays the measured temperature of the top rectifier IGBT power module in degrees C.

This parameter is only present on frame 4 drives. All such drives should have firmware version numbers in the 2.x series.

346 Rct IGBT Tmp Up

Range: -3276.8 to 3276.7 Degrees C

Default: Read Only

Access: 1 **Path:** Inputs & Outputs>Temperature etc

See also: 345, 347, 348

Displays the measured temperature of the upper rectifier IGBT power module in degrees C.

This parameter is only present on frame 4 drives. All such drives should have firmware version numbers in the 2.x series.

347 Rct IGBT Tmp Low

Range: -3276.8 to 3276.7 Degrees C

Default: Read Only

Access: 1 **Path:** Inputs & Outputs>Temperature etc

See also: 345, 346, 348

Displays the measured temperature of the lower rectifier IGBT power module in degrees C.

This parameter is only present on frame 4 drives. All such drives should have firmware version numbers in the 2.x series.

348 Rct IGBT Tmp Bot

Range: -3276.8 to 3276.7 Degrees C

Default: Read Only

Access: 1 **Path:** Inputs & Outputs>Temperature etc

See also: 345, 346, 347

Displays the measured temperature of the bottom rectifier IGBT power module in degrees C.

This parameter is only present on frame 4 drives. All such drives should have firmware version numbers in the 2.x series.

349 Rct Coldplt Tmp

Range: -3276.8 to 3276.7 Degrees C

Default: Read Only

Access: 1 **Path:** Inputs & Outputs>Temperature etc

See also:

Displays the measured rectifier coldplate temperature in degrees C. This parameter is only usable if a coldplate temperature sensor is installed in the drive.

This parameter is only present on frame 4 drives. All such drives should have firmware version numbers in the 2.x series.

350 Rct Ambient Tmp

Range: -3276.8 to 3276.7 Degrees C

Default: Read Only

Access: 1 **Path:** Inputs & Outputs>Temperature etc

See also:

Displays the measured ambient temperature of the drive in degrees C.

This parameter is only present on frame 4 drives. All such drives should have firmware version numbers in the 2.x series.

351 Rct PS Tmp

Range: -3276.8 to 3276.7 Degrees C

Default: Read Only

Access: 1 **Path:** Inputs & Outputs>Temperature etc

See also:

Displays the measured drive power supply temperature in degrees C.

This parameter is only present on frame 4 drives. All such drives should have firmware version numbers in the 2.x series.

352 Rct PS +12V

Range: -3276.8V to 3276.7V Degrees C

Default: Read Only

Access: 1 **Path:** Inputs & Outputs>Temperature etc

See also:

Displays the measured voltage of the +12V power supply.

This parameter is only present on frame 4 drives. All such drives should have firmware version numbers in the 2.x series.

353 Rct PS -12V

Range: -3276.8V to 3276.7V Degrees C

Default: Read Only

Access: 1 **Path:** Inputs & Outputs>Temperature etc

See also:

Displays the measured voltage of the -12V power supply.

This parameter is only present on frame 4 drives. All such drives should have firmware version numbers in the 2.x series.

354 Rct I/O ID V

Range: -3276.8V to 3276.7V Degrees C

Default: Read Only

Access: 1 **Path:** Inputs & Outputs>Temperature etc

See also:

Displays the measured voltage that identifies which type of IO board is installed.

This parameter is only present on frame 4 drives. All such drives should have firmware version numbers in the 2.x series.

Troubleshooting the Drive



ATTENTION: Only qualified electrical personnel familiar with the construction and operation of this equipment and the hazards involved should install, adjust, operate, or service this equipment. Read and understand this manual and other applicable manuals in their entirety before proceeding. Failure to observe this precaution could result in severe bodily injury or loss of life.

The LiquiFlo 2.0 AC drive provides the following ways to determine the status of the drive and to troubleshoot problems that may occur:

- LEDs on the front of the drive
- User-configurable and non-configurable alarms
- User-configurable and non-configurable faults
- Entries in the fault queue
- Drive status parameters

10.1 Verifying that DC Bus Capacitors are Discharged Before Servicing the Drive



ATTENTION: DC bus capacitors retain hazardous voltages after input power has been disconnected. After disconnecting input power, wait five (5) minutes for the DC bus capacitors to discharge and then check the voltage with a voltmeter to ensure the DC bus capacitors are discharged before touching any internal components. Failure to observe this precaution could result in severe bodily injury or loss of life.

The drive's DC bus capacitors retain hazardous voltages after input power has been disconnected. Perform the following steps before touching any internal components.

- Step 1. Turn off the circuit breaker and lock out input power. Wait 5 minutes.
- Step 2. Open the enclosure door to the power module.
- Step 3. Verify that there is no voltage at the power module's input power terminals (L1, L2, and L3) as shown in figure 2.2.
- Step 4. Remove the power module's cover.
- Step 5. Measure the DC bus potential with a voltmeter while standing on a non-conductive surface and wearing insulated gloves. Refer to figure 10.1 for frame 3 and figure 10.2 for frame 4.
- Step 6. Once the drive has been serviced, reattach the power module cover and close the enclosure door.
- Step 7. Turn on the circuit breaker.

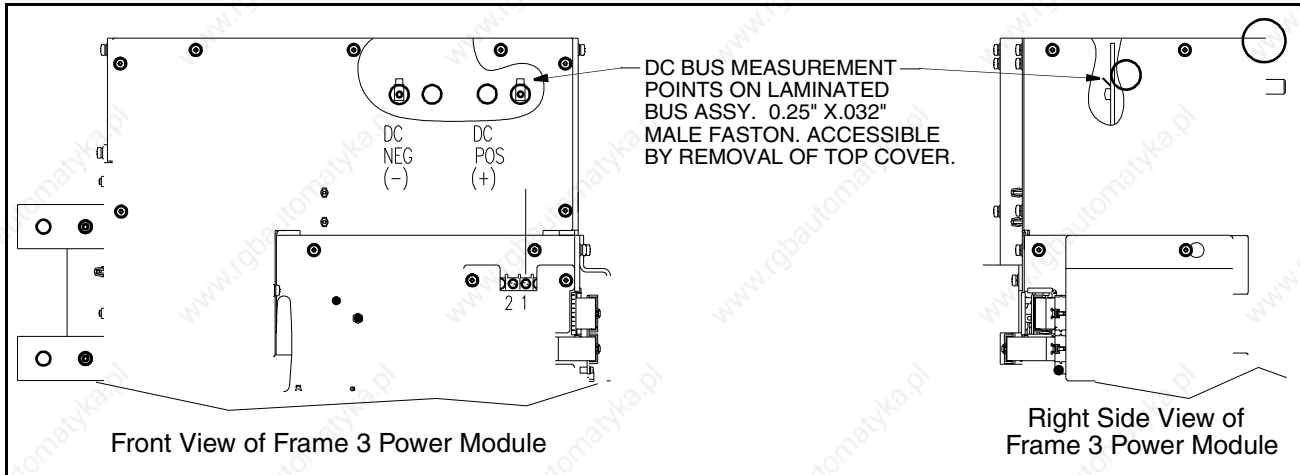

Figure 10.1 – Location of DC Bus Measuring Points (Frame 3)

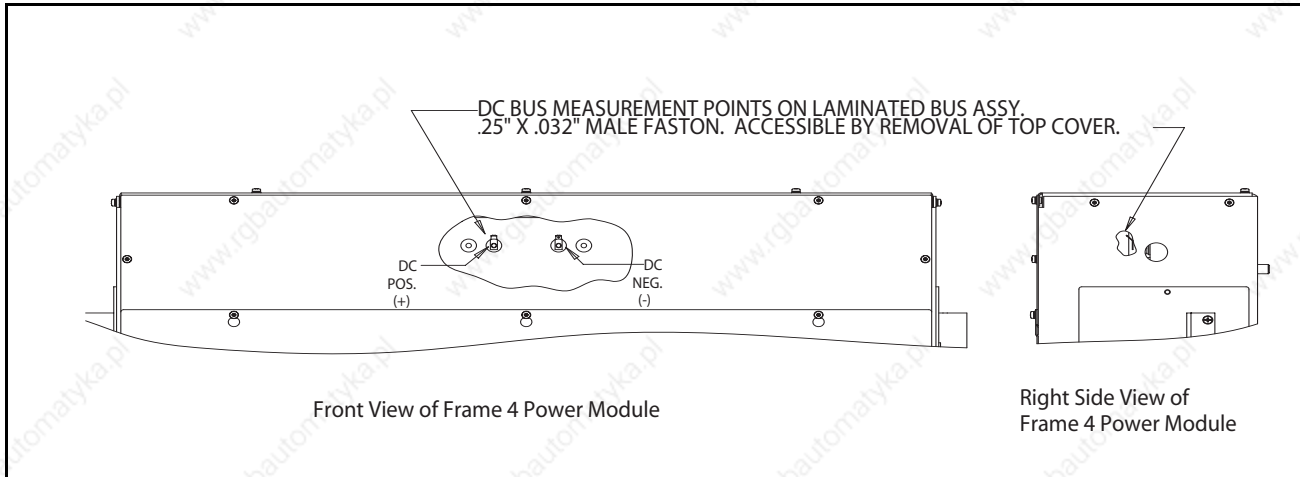

Figure 10.2 – Location of DC Bus Measuring Points (Frame 4)

10.2 Determining Drive Status Using the Status LEDs

The inverter and rectifier sections each have a status LED.

For frame 3 drives, the status LEDs are located on the Communication Interface board, and are labeled on the board itself as “INV STATUS” (inverter) and “ACTIVE RECT. STATUS” (rectifier). See figure 10.3.

For frame 4 drives, the status LEDs are located on the Control Board, and are labeled on the board itself as “B2” (inverter) and “B1” (rectifier). See figure 10.4.

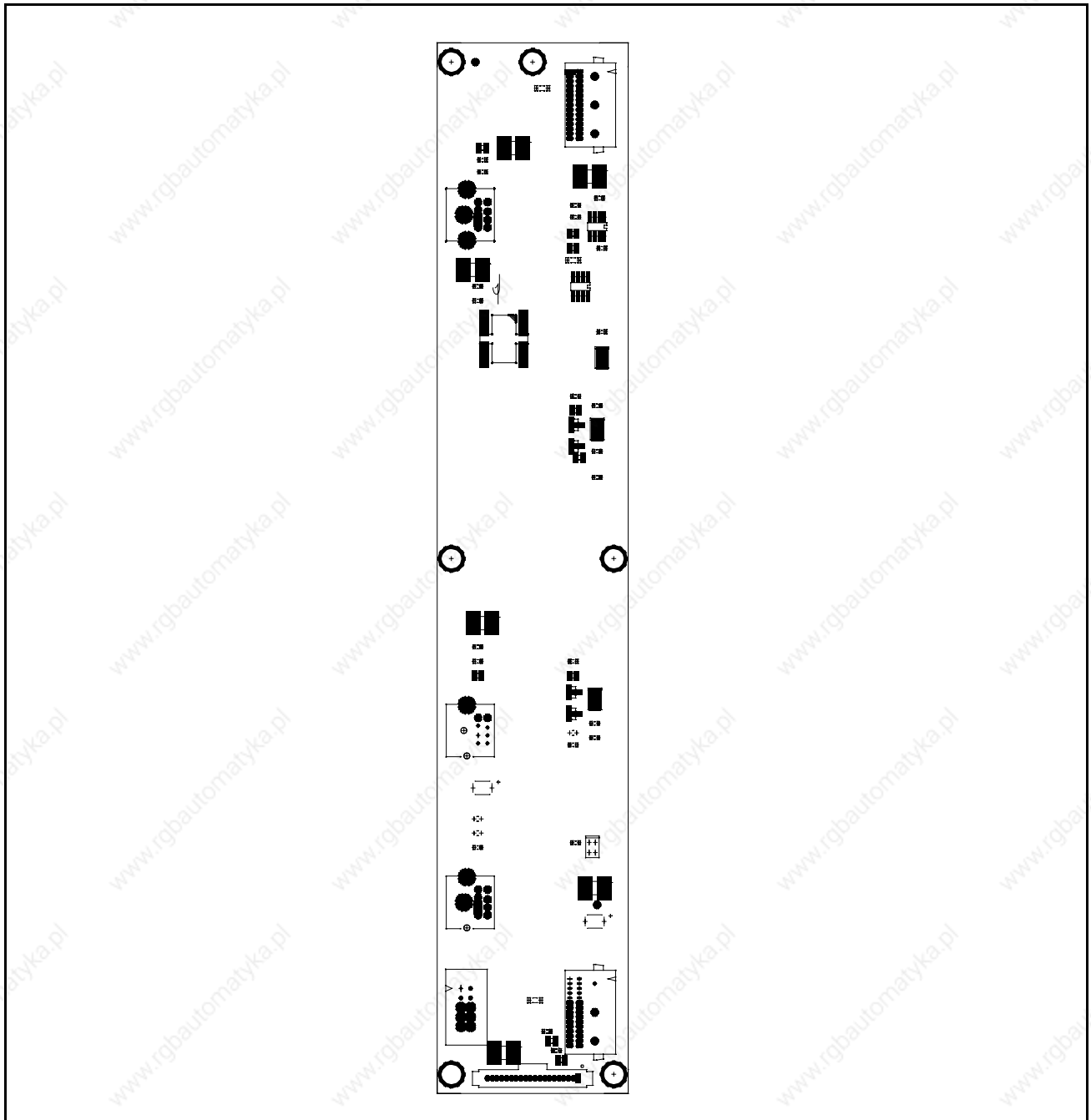

Figure 10.3 – Location of the Status LEDs (Frame 3)

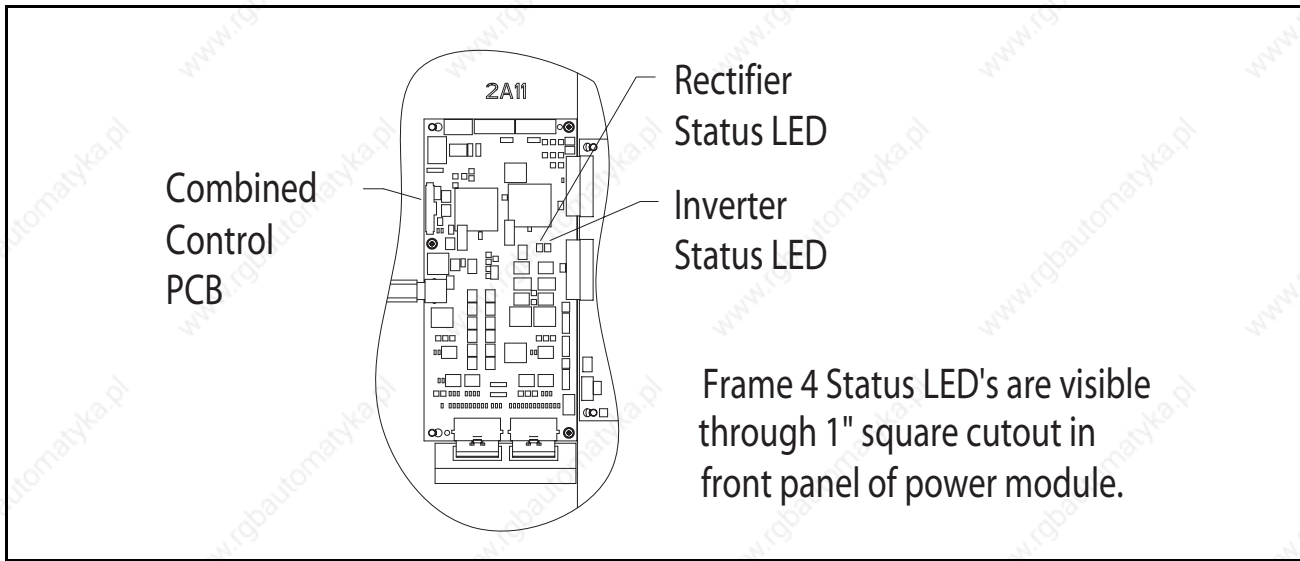

Figure 10.4 – Location of the Status LEDs (Frame 4)

Table 10.1 – Inverter Status LED Definitions

Color	State	Description
Green	Flashing	Drive ready, but not running and no faults are present.
	Steady	Drive running, no faults or alarms are present.
Yellow See section 11.3.	Flashing	The drive is not ready. Check inverter parameter 214 (Start Inhibits).
	Steady	An alarm condition exists; drive may be running. Check inverter parameters 211 (Drive Alarm 1) and 212 (Drive Alarm 2).
Red See section 10.4.	Flashing	A fault has occurred.
	Steady	A non-resettable fault has occurred.

Table 10.2 – Rectifier Status LED Definitions

Color	State	Description
Green	Flashing	Rectifier ready, but not running and no faults are present.
	Steady	Rectifier running (providing current to inverter).
Yellow	Flashing	Rectifier is not ready. Check rectifier parameter 214 (Start Inhibits). This is the normal state if the inverter is not running and/or the precharge is open.
	Steady	A rectifier alarm condition exists; rectifier may be running. Check rectifier parameter 211 (Alarm Status).
Red	Flashing	A rectifier fault has occurred. This also causes an inverter fault, and the fault will be enunciated on the OIM or other DPI device.
	Steady	A non-resettable rectifier fault has occurred.

Certain hardware failures will produce indications on the status LEDs that are not covered in the above tables. For frame 3 drives, the appropriate response to the appearance of any of these indications is to replace either the Rectifier Control board or Inverter Control board depending on which LED displays the indication. For frame 4 drives, the appropriate response is always to replace the Control board. Table 10.3 lists the indications.

Table 10.3 – Status LED Definitions for Hardware Failure

LED Indication	Condition
Red/green alternating	Control board boot firmware is running because control board application firmware is corrupted.
Yellow/ green/ red repeating pattern	Control board RAM has failed or control board boot firmware is corrupted.

10.3 About Alarms

Alarms indicate conditions that may affect drive operation or application performance.

There are two alarm types, as described in table 10.4.

Table 10.4 – Types of Alarms

Type	Alarm Description
①	<p>User-Configurable These alarms alert the operator of conditions that, if left untreated, may lead to a fault condition. The drive continues to operate during the alarm condition.</p> <p>The alarms are enabled or disabled using inverter Alarm Config 1 (259).</p> <p>The status of these alarms is shown in inverter Drive Alarm 1 (211).</p>
②	<p>Non-Configurable These alarms alert the operator of conditions caused by improper programming and prevent the drive from starting until the problem is resolved.</p> <p>These alarms are always enabled.</p> <p>The status of these alarms is shown in inverter Drive Alarm 2 (212).</p>

The drive indicates alarm conditions in the following ways:

- Status LEDs (see section 10.2).
- Alarm name and bell graphic on the LCD OIM (see Appendix B). The alarm is displayed as long as the condition exists. The drive automatically clears the alarm when the condition causing it is removed.
- Alarm status parameters. Two 16-bit inverter parameters, Drive Alarm 1 (211) and Drive Alarm 2 (212), indicate the status of type 1 and type 2 alarms, respectively. Refer to chapter 10 for the parameter descriptions.

10.3.1 Alarm Descriptions

Table 10.5 – Alarm Descriptions

Alarm	Type	Description																																																																																																				
Analog In Loss	①	An analog input is configured for alarm on signal loss and signal loss has occurred.																																																																																																				
Bipolar Conflict	②	Parameter 190 (Direction Mode) is set to Bipolar or Reverse Dis and one of more of the following digital input functions is configured: Fwd/Rev, Run Fwd, Run Rev, Jog Fwd, or Jog Rev.																																																																																																				
Dig In ConflictA	②	Digital input functions are in conflict. Combinations marked with a # will cause an alarm. <table border="1" style="margin-left: 40px;"> <thead> <tr> <th></th> <th>Acc2 / Dec2</th> <th>Accel 2</th> <th>Decel 2</th> <th>Jog</th> <th>Jog Fwd</th> <th>Jog Rev</th> <th>Fwd / Rev</th> </tr> </thead> <tbody> <tr> <td>Acc2 / Dec2</td> <td></td> <td>#</td> <td>#</td> <td></td> <td></td> <td></td> <td></td> </tr> <tr> <td>Accel 2</td> <td>#</td> <td></td> <td></td> <td></td> <td></td> <td></td> <td></td> </tr> <tr> <td>Decel 2</td> <td>#</td> <td></td> <td></td> <td></td> <td></td> <td></td> <td></td> </tr> <tr> <td>Jog</td> <td></td> <td></td> <td></td> <td></td> <td>#</td> <td>#</td> <td></td> </tr> <tr> <td>Jog Fwd</td> <td></td> <td></td> <td></td> <td>#</td> <td></td> <td></td> <td>#</td> </tr> <tr> <td>Jog Rev</td> <td></td> <td></td> <td></td> <td>#</td> <td></td> <td></td> <td>#</td> </tr> <tr> <td>Fwd / Rev</td> <td></td> <td></td> <td></td> <td></td> <td>#</td> <td>#</td> <td></td> </tr> </tbody> </table>		Acc2 / Dec2	Accel 2	Decel 2	Jog	Jog Fwd	Jog Rev	Fwd / Rev	Acc2 / Dec2		#	#					Accel 2	#							Decel 2	#							Jog					#	#		Jog Fwd				#			#	Jog Rev				#			#	Fwd / Rev					#	#																																					
	Acc2 / Dec2	Accel 2	Decel 2	Jog	Jog Fwd	Jog Rev	Fwd / Rev																																																																																															
Acc2 / Dec2		#	#																																																																																																			
Accel 2	#																																																																																																					
Decel 2	#																																																																																																					
Jog					#	#																																																																																																
Jog Fwd				#			#																																																																																															
Jog Rev				#			#																																																																																															
Fwd / Rev					#	#																																																																																																
Dig In ConflictB	②	Digital input functions are in conflict. Combinations marked with a # will cause an alarm. <table border="1" style="margin-left: 40px;"> <thead> <tr> <th></th> <th>Start</th> <th>Stop-CF</th> <th>Run</th> <th>Run Fwd</th> <th>Run Rev</th> <th>Jog</th> <th>Jog Fwd</th> <th>Jog Rev</th> <th>Fwd/ Rev</th> </tr> </thead> <tbody> <tr> <td>Start</td> <td></td> <td></td> <td>#</td> <td>#</td> <td>#</td> <td></td> <td>#</td> <td>#</td> <td></td> </tr> <tr> <td>Stop-CF</td> <td></td> <td></td> <td></td> <td></td> <td></td> <td></td> <td></td> <td></td> <td></td> </tr> <tr> <td>Run</td> <td>#</td> <td></td> <td></td> <td>#</td> <td>#</td> <td></td> <td>#</td> <td>#</td> <td></td> </tr> <tr> <td>Run Fwd</td> <td>#</td> <td></td> <td>#</td> <td></td> <td></td> <td>#</td> <td></td> <td></td> <td>#</td> </tr> <tr> <td>Run Rev</td> <td>#</td> <td></td> <td>#</td> <td></td> <td></td> <td>#</td> <td></td> <td></td> <td>#</td> </tr> <tr> <td>Jog</td> <td></td> <td></td> <td></td> <td>#</td> <td>#</td> <td></td> <td></td> <td></td> <td></td> </tr> <tr> <td>Jog Fwd</td> <td>#</td> <td></td> <td>#</td> <td></td> <td></td> <td></td> <td></td> <td></td> <td></td> </tr> <tr> <td>Jog Rev</td> <td>#</td> <td></td> <td>#</td> <td></td> <td></td> <td></td> <td></td> <td></td> <td></td> </tr> <tr> <td>Fwd / Rev</td> <td></td> <td></td> <td></td> <td>#</td> <td>#</td> <td></td> <td></td> <td></td> <td></td> </tr> </tbody> </table>		Start	Stop-CF	Run	Run Fwd	Run Rev	Jog	Jog Fwd	Jog Rev	Fwd/ Rev	Start			#	#	#		#	#		Stop-CF										Run	#			#	#		#	#		Run Fwd	#		#			#			#	Run Rev	#		#			#			#	Jog				#	#					Jog Fwd	#		#							Jog Rev	#		#							Fwd / Rev				#	#				
	Start	Stop-CF	Run	Run Fwd	Run Rev	Jog	Jog Fwd	Jog Rev	Fwd/ Rev																																																																																													
Start			#	#	#		#	#																																																																																														
Stop-CF																																																																																																						
Run	#			#	#		#	#																																																																																														
Run Fwd	#		#			#			#																																																																																													
Run Rev	#		#			#			#																																																																																													
Jog				#	#																																																																																																	
Jog Fwd	#		#																																																																																																			
Jog Rev	#		#																																																																																																			
Fwd / Rev				#	#																																																																																																	
Dig In ConflictC	②	More than one physical input has been configured to the same input function. Multiple configurations are not allowed for the following input functions: <table style="margin-left: 40px; width: 100%;"> <tr> <td>Forward/Reverse</td> <td>Run Reverse</td> <td>Bus Regulation Mode B</td> </tr> <tr> <td>Speed Select 1</td> <td>Jog Forward</td> <td>Acc2 / Dec2</td> </tr> <tr> <td>Speed Select 2</td> <td>Jog Reverse</td> <td>Accel 2</td> </tr> <tr> <td>Speed Select 3</td> <td>Stop Mode B</td> <td>Decel 2</td> </tr> <tr> <td>Run Forward</td> <td></td> <td>Run</td> </tr> </table>	Forward/Reverse	Run Reverse	Bus Regulation Mode B	Speed Select 1	Jog Forward	Acc2 / Dec2	Speed Select 2	Jog Reverse	Accel 2	Speed Select 3	Stop Mode B	Decel 2	Run Forward		Run																																																																																					
Forward/Reverse	Run Reverse	Bus Regulation Mode B																																																																																																				
Speed Select 1	Jog Forward	Acc2 / Dec2																																																																																																				
Speed Select 2	Jog Reverse	Accel 2																																																																																																				
Speed Select 3	Stop Mode B	Decel 2																																																																																																				
Run Forward		Run																																																																																																				
Drive OL Level 1	①	The calculated IGBT temperature requires a reduction in PWM carrier frequency. If Drive OL Mode (150) is disabled and the load is not reduced, an overload fault will eventually occur.																																																																																																				
Drive OL Level 2	①	The calculated IGBT temperature requires a reduction in Current Limit. If Drive OL Mode (150) is disabled and the load is not reduced, an overload fault will eventually occur.																																																																																																				

Table 10.5 – Alarm Descriptions (Continued)

Alarm	Type	Description
Flux Amps Ref Rang	②	Result of autotune procedure (61).
IntDBRes OvrHeat	①	The drive has temporarily disabled the dynamic braking regulator because the resistor temperature has exceeded a predetermined value.
IR Volts Range	②	The drive autotuning default is Calculate and the value calculated for IR Drop Volts is not in the range of acceptable values. This alarm should clear when all motor nameplate data is properly entered.
MaxFreq Conflict	②	The sum of Maximum Speed (82) and Overspeed Limit (83) exceeds Maximum Freq (55). Raise Maximum Freq (55) or lower Maximum Speed (82) and/or Overspeed Limit (83) so that the sum is less than or equal to Maximum Freq (55).
Motor Type Cflct	②	Motor Type (90) has been set to Sync Prm Mag or Sync Reluc, and one or more DC functions (for example, DC Boost, DC Brake, etc.) have been activated. DC injection functions are incompatible with synchronous motors and may demagnetize them.
NP Hz Conflict	②	Fan/pump mode is selected in Torq Perf Mode (53), and the ratio of Motor NP Hertz (43) to Maximum Freq (55) is greater than 26.
Power Loss	①	Drive has sensed a power line loss.
Prechrg Actv	①	Drive is in the initial DC bus precharge state.
Speed Ref Cflct	②	Speed Ref x Sel or PI Reference Sel is set to “Reserved”.
Under-Voltage	①	The bus voltage has dropped below a predetermined value.
VHz Neg Slope	②	Custom V/Hz mode has been selected in Torq Perf Mode (53) and the V/Hz slope is negative.

Table 10.6 – Alarm Names Cross-Referenced by Alarm Numbers

No. ¹	Alarm	No. ¹	Alarm
1	Precharge Active	20	Bipolar Conflict
2	UnderVoltage	21	Motor Type Conflict
3	Power Loss	22	NP Hz Conflict
5	Analog In Loss	23	MaxFreq Conflict
6	IntDBRes OvrHeat	24	VHz Neg Slope
8	Drive OL Level 1	25	IR Volts Range
9	Drive OL Level 2	26	FluxAmps Ref Rang
17	Dig In ConflictA	27	Speed Ref Cflct
18	Dig In ConflictB		
19	Dig In ConflictC		

¹ Alarm numbers not listed are reserved for future use.

10.4 About Faults

Faults indicate conditions within the drive that require immediate attention. The drive responds to a fault by initiating a coast-to-stop sequence and turning off output power to the motor.

In addition, some faults are auto-resettable, non-resettable, and/or user-configurable as described in table 10.7.

Table 10.7 – Fault Types

Type	Fault Description	
①	Auto-Reset/Run	If the drive is running when this type of fault occurs, and Auto Rstrt Tries (174) is set to a value greater than 0, a user-configurable timer, Auto Rstrt Delay (175) begins. When the timer reaches zero, the drive attempts to automatically reset the fault. If the condition that caused the fault is no longer present, the fault will be reset and the drive will be restarted.
②	Non-Resettable	This type of fault normally requires drive or motor repair. The cause of the fault must be corrected before the fault can be cleared. The fault will be reset on power up after repair.
③	User-Configurable	These faults can be enabled/disabled to either annunciate or ignore a fault condition using Fault Config 1 (238).

The drive indicates faults in the following ways:

- Status LEDs on the drive control panel (see section 10.2).
- Drive status parameters Drive Status 1 (209) and Drive Status 2 (210).
- Entries in the fault queue (see section 10.4.1).
- Pop-up screen on the LCD OIM. See figure 10.5. The screen displays:
 - Fault number
 - Fault name
 - Time that has elapsed since fault occurred.

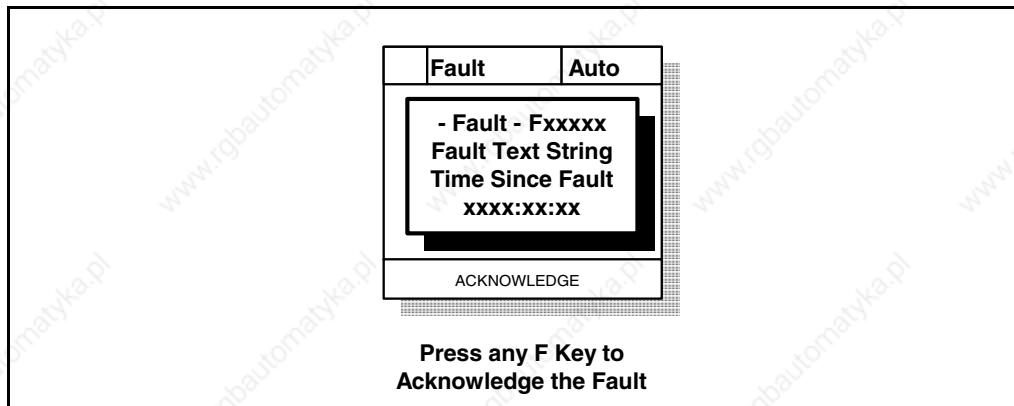

Figure 10.5 – Sample Fault Screen on the LCD OIM

The fault screen is displayed until it is acknowledged by pressing any F-key or cleared in the drive by other means.

10.4.1 About the Fault Queue

The drive automatically retains a history of faults that have occurred in the fault queue. The fault queue is accessed using the OIM or VS Utilities software.

The fault queue holds the eight most recent faults. The last fault to occur is indicated in queue entry #1. As new faults are logged into the queue, existing fault entries are shifted (for example, entry #1 will move to entry #2). Once the queue is full, older faults are discarded from the queue as new faults occur.

All entries in the fault queue are retained if power is lost.

The Time Stamp

For each entry in the fault queue, the system also displays a fault code and time stamp value. The time stamp value is the value of an internal drive-under-power timer at the time of the fault. The value of this timer is copied to PowerUp Marker (242) when the drive powers up. The fault queue time stamp can then be compared to the value in PowerUp Marker to determine when the fault occurred relative to the last drive power up.

The time stamp is cleared when the fault queue is cleared.

Refer to section 10.8.1 for information on accessing the fault queue using the LCD OIM. Refer to instruction manual D2-3488 for information on accessing the fault queue using VS Utilities software.

10.4.2 Clearing Faults

A fault condition can be cleared by the following:

- Step 1. Press  or any F-Key to acknowledge the fault and remove the fault pop-up from the LCD OIM screen.
- Step 2. Address the condition that caused the fault. The cause must be corrected before the fault can be cleared.
- Step 3. After corrective action has been taken, clear the fault using one of the following:
 - Setting Fault Clear (240) to Clear Faults (1).
 - Issuing a Stop-Clear Faults command from the control device (such as an OIM). This action will only succeed if the clear faults function for that device is enabled using the Logic Mask (276) and Fault Clr Mask (283).

Resetting faults will clear the faulted status indication. If any fault condition still exists, the fault will be latched, and another entry made in the fault queue.

Note that performing a fault reset does not clear the fault queue. Clearing the fault queue is a separate action. See the Fault Clear (240) parameter description.

10.4.3 Fault Descriptions and Corrective Actions

Important: Read all faults from the inverter. Although rectifier faults occur, they are displayed on the inverter.

10.4.3.1 Frame 3 Fault Descriptions and Corrective Actions

Table 10.8 describes drive faults and corrective actions for frame 3 (firmware version 1.x only). The table also indicates the fault type.

- ① Auto-resettable
- ② Non-resettable
- ③ User-configurable
- ④ Normal Fault*

*The fault is resettable using normal fault clearing mechanisms on the drive (Stop/Reset button, powercycling, etc.) or through V*S Utilities.

Table 10.8 – Fault Descriptions and Corrective Actions (Frame 3)

Fault	No.	Type	Description	Action
AC Line Lost	227	④	Input power Lost	<ol style="list-style-type: none"> 1. Verify proper input voltage. 2. Check line sync board and fuse. 3. Check AC line I/O board. 4. Verify connection between boards.
Analog In Loss	29	①	<p>An analog input is configured to fault on signal loss. A signal loss has occurred.</p> <p>Configure with Anlg In 1, 2 Loss (324, 327).</p>	<ol style="list-style-type: none"> 1. Check parameters. 2. Check for broken/loose connections at inputs.
Auto Rstrt Tries	33	③	<p>Drive unsuccessfully attempted to reset a fault and resume running for the programmed number of Auto Rstrt Tries (174).</p> <p>Enable/disable with Fault Config 1 (238).</p>	Correct the cause of the fault and manually clear.
AutoTune Aborted	80	④	The autotune procedure was canceled by the user.	Restart procedure.
Auxiliary Input	2	①	A user-configurable digital input is configured to "Aux. Fault" and the input is open.	<ol style="list-style-type: none"> 1. Check digital wiring. 2. Configure the digital input to something else with inverter Digital In Sel parameter (361-366).
Current Fbk Lost	35	④	<p>The magnitude of motor current feedback was less than 5% Motor NP FLA (42) for the time configured in Imbalance Time (50).</p> <p>Detection of this fault is disabled when Imbalance Time (50) is set to the maximum value of 10.0 seconds.</p>	<ol style="list-style-type: none"> 1. Verify connection of current feedback device and motor terminals. 2. If fault repeats, replace current feedback devices and/or power supply.

Table 10.8 – Fault Descriptions and Corrective Actions (Continued)(Frame 3)

Fault	No.	Type	Description	Action
Decel Inhibit	24	③	The drive is not following a commanded deceleration because it is attempting to limit bus voltage.	<ol style="list-style-type: none"> 1. Verify input voltage is within drive specified limits. 2. Verify system ground impedance follows proper grounding techniques. 3. Disable bus regulation and/or add dynamic brake resistor and/or extend deceleration time.
Drive OverLoad	64	①	Drive rating of 110% for 1 minute or 150% for 3 seconds has been exceeded.	Reduce load or extend Accel Time (140).
Excessive Load	79	④	Motor did not come up to speed in the allotted time.	<ol style="list-style-type: none"> 1. Uncouple load from motor. 2. Repeat Autotune (61).
FluxAmpsRef Rang	78	④	The value for flux amps determined by the autotune procedure exceeds the programmed Motor NP FLA (42).	<ol style="list-style-type: none"> 1. Reprogram Motor NP FLA (42) with the correct motor nameplate value. 2. Repeat Autotune (61).
Ground Fault	13	①	A current path to earth ground in excess of 7% of drive rated amps has been detected at one or more of the drive output terminals.	Check the motor and external wiring to the drive output terminals for a grounded condition.
High AC Line	222	④	Input line voltage is too high.	Reduce input voltage to meet specification of 480 ±10%.
HW Fault	70	④	Inverter section of power structure hardware detected an unexpected fault during power stage diagnostics.	Replace inverter power board.
HW OverCurrent	12	①	The drive output current has exceeded the hardware current limit.	Check programming. Check for excess load, improper DC boost setting, DC brake volts set too high or other causes of excess current.
I/O Board Fail	122	②	Board failure.	<ol style="list-style-type: none"> 1. Cycle power. 2. If fault repeats, replace inverter I/O board

Table 10.8 – Fault Descriptions and Corrective Actions (Continued)(Frame 3)

Fault	No.	Type	Description	Action
I/O Board Comm Loss	121	②	Loss of communication to I/O board.	<ol style="list-style-type: none"> 1. Cycle power. 2. If fault persists, verify connection between inverter I/O board and inverter control board. 3. If fault still persists, replace inverter I/O board. 4. If fault still persists, replace inverter control board.
I/O Mismatch	120	④	Incorrect I/O board identified.	Restore I/O board to original configuration, or If new configuration is desired, reset fault.
Incompat MCB-PB	106	②	Drive rating information stored on the power board is incompatible with the Main Control board.	Load compatible version files into inverter.
Input I Imbalance	225	④	Input phase current imbalance exceeded limits.	Check for loose connection in input power wiring.
Input V Imbalance	226	④	Input voltage imbalance exceeded limits.	Check for problem in input power distribution.
Invtr Base Temp	8	①	Base temperature exceeded limit.	Check for proper temperature and flow rate of coolant.
Invtr Dsat U, V, W	200 201 202	④	High current was detected in an IGBT.	<ol style="list-style-type: none"> 1. Check for loose connection in IGBT wire harness. 2. Check IGBTs.
Invtr Gate Kill	207	④	Inverter gate kill contact is open.	Close gate kill contact.
Invtr HW Unk	230	④	Inverter section of power structure hardware reported unexpected fault.	<ol style="list-style-type: none"> 1. Verify connection between inverter control board and inverter power board. 2. If fault persists, replace inverter power board. 3. If fault still persists, replace inverter control board.
Invtr HW Unused	206	④	Inverter section of power structure hardware reported unexpected fault.	<ol style="list-style-type: none"> 1. Verify connection between inverter control board and inverter power board. 2. If fault persists, replace inverter power board. 3. If fault still persists, replace inverter control board.
Invtr IGBT Temp	9	①	Output transistors have exceeded their maximum operating temperature.	Check for proper temperature and flow rate of coolant.

Table 10.8 – Fault Descriptions and Corrective Actions (Continued)(Frame 3)

Fault	No.	Type	Description	Action
Invtr OverCurrent U, V, W	203 204 205	④	High current was detected in an IGBT.	1. Verify proper motor data is entered. 2. Reduce current limit.
IR Volts Range	77	④	The drive autotuning default is Calculate, and the value calculated for IR Drop Volts is not in the range of acceptable values.	Re-enter motor nameplate data.
Ixo Voltage-Range	87	④	Ixo voltage calculated from motor nameplate data is too high.	1. If Ixo calculation is not needed, disable it by clearing bit 2 of Compensation (inverter parameter 56), then clear fault. 2. If Ixo calculation is needed, re-enter motor nameplate data, and, if necessary, repeat Autotune (61).
Line Feq Lost	228	④	Line frequency not in the range of 47-63 Hz.	Verify connection between AC Line Sync and AC Line I/O boards.
Low DC Bus	223	④	The bus voltage is too low.	Verify proper input voltage.
Motor I Imbalnce	37	④	The motor current imbalance displayed in Imbalance Count (221) has exceeded Imbalance Limit (49) for time configured in Imbalance Time (50).	Clear fault.
Motor Overload	7	① ③	Internal electronic overload trip. Enable/disable with Fault Config 1 (238). Overload threshold is set using inverter Motor OL Amps.	An excessive motor load exists. Reduce load so drive output current does not exceed the current set by Motor NP FLA (42).
Not At Voltage	237	④	The rectifier did not regulate to the desired bus voltage within the defined time.	1. Check all fuses and cabinet wiring. 2. Replace line sync board. 3. Replace AC Line I/O board. 4. Replace rectifier control board and/or rectifier power board.

Table 10.8 – Fault Descriptions and Corrective Actions (Continued)(Frame 3)

Fault	No.	Type	Description	Action
OverSpeed Limit	25	①	Functions such as slip compensation or bus regulation have attempted to add an output frequency adjustment greater than that programmed in Overspeed Limit (83).	Remove excessive load or overhauling conditions or increase Overspeed Limit (83).
OverVoltage	5	①	DC bus voltage exceeded maximum value.	Monitor the AC line for high line voltage or transient conditions. Bus overvoltage can also be caused by motor regeneration. Extend the decel time or install dynamic brake option.
Parameter Chksum	100	②	The calculated checksum does not match the stored checksum for parameter values read from non-volatile memory.	<ol style="list-style-type: none"> 1. Restore inverter defaults using inverter Restore Defaults parameter (197). 2. Reload user set if used, or reprogram inverter parameters. 3. If fault recurs, replace inverter control board.
Params Defaulted	48	④	The drive was commanded to write default values to all inverter parameters.	<ol style="list-style-type: none"> 1. Clear the fault or cycle power to the drive. 2. Program the drive parameters as needed.
Phase U to Grnd	38	④	A phase-to-ground fault has been detected between the drive and motor in this phase.	<ol style="list-style-type: none"> 1. Check the wiring between the drive and motor. 2. Check motor for grounded phase.
Phase V to Grnd	39	④		
Phase W to Grnd	40	④		
Phase UV Short	41	④	Excessive current has been detected between these two output terminals.	<ol style="list-style-type: none"> 1. Check the motor and drive output terminal wiring for a shorted condition.
Phase VW Short	42	④		
Phase UW Short	43	④		
Port 1-5 Adapter	71-75	④	<p>The network card connected to DPI port stopped communicating.</p> <p>The fault code indicates the offending port number (71 = port 1, etc.).</p>	<ol style="list-style-type: none"> 1. Check communication board for proper connection to external network. 2. Check external wiring to module on port. 3. Verify external network fault.

Table 10.8 – Fault Descriptions and Corrective Actions (Continued)(Frame 3)

Fault	No.	Type	Description	Action
Port 1-5 DPI Loss	81-85	④	DPI port stopped communicating. An attached peripheral with control capabilities was removed. Fault 82 indicates specifically that the rectifier stopped communicating with the inverter.	<ol style="list-style-type: none"> If DPI device was not intentionally disconnected, check wiring to the port. Replace wiring, port expander, peripherals, communications interface board, or inverter control board as required. If fault 82 occurs, check wiring between communications interface board and the two control boards. Replace communications interface board, rectifier control board, or inverter control board as required.
Power Loss	3	① ③	DC bus voltage remained below 85% of nominal for longer than Power Loss Time (185). Enable/disable with Fault Config 1 (238).	Monitor the incoming AC line for low voltage or line power interruption.
Power Phased ACB	239	④	Input power is phased ACB rather than ABC.	Switch two of the input power phases.
Precharge closed	233	④	Precharge was closed when it should be open.	<ol style="list-style-type: none"> Check AUX contacts on precharge. Check input bit 0 in rectifier parameter 216 to view status of input. Check wiring.
Precharge open	234	④	Precharge was open when it should be closed.	<ol style="list-style-type: none"> Check AUX contacts on precharge. Check input bit 0 in rectifier parameter 216 to view status of input. Check wiring.
Pwr Brd Chksum1	104	④	The checksum read from the EEPROM does not match the checksum calculated from the EEPROM data.	Clear the fault or cycle power to the drive.
Pwr Brd Chksum2	105	②	The checksum read from the board does not match the checksum calculated.	<ol style="list-style-type: none"> Cycle power to the drive. If problem persists, replace inverter power board.
Rctfr Base Temp	217	④	Excessive rectifier temperature measured.	Check for proper temperature and flow rate of coolant.

Table 10.8 – Fault Descriptions and Corrective Actions (Continued)(Frame 3)

Fault	No.	Type	Description	Action
Rctfr Checksum	229	④	The parameter checksum read from the rectifier control board does not match the checksum calculated, or the rectifier power board has been replaced.	<ol style="list-style-type: none"> 1. Clear fault. 2. If fault persists, restore defaults on rectifier (rectifier parameter 197), then reprogram rectifier parameters. 3. If fault still persists, replace rectifier control board or rectifier power board.
Rctfr Dsat R, S, T	208 209 210	④	High current was detected in an IGBT.	<ol style="list-style-type: none"> 1. Check for loose connection in IGBT wire harness. 2. Check IGBTs.
Rctfr Grnd Fault	216	④	Excessive ground current measured.	Check for grounded input wiring.
Rctfr HW Unk	231	④	Rectifier portion of power structure hardware reported unexpected fault.	<ol style="list-style-type: none"> 1. Verify connection between rectifier control board and rectifier power board. 2. If fault persists, replace rectifier power board. 3. If fault still persists, replace rectifier inverter control board.
Rctfr HW Unused	215	④	Rectifier portion of power structure hardware reported unexpected fault.	<ol style="list-style-type: none"> 1. Verify connection between rectifier control board and rectifier power board. 2. If fault persists, replace rectifier power board. 3. If fault still persists, replace rectifier inverter control board.
Rctfr I2T Ovrld	220	④	Long-term current rating of rectifier exceeded.	Low input voltage can result in increased current load. Provide proper input voltage to the drive.
Rctfr IGBT Temp	218	④	Excessive calculated IGBT temperature.	Check for proper temperature and flow rate of coolant.
Rctfr I/O Board	236	②	Loss of communication to I/O board. Board failure.	<ol style="list-style-type: none"> 1. Clear fault. 2. If fault persists, verify connection between rectifier I/O board and rectifier control board. 3. If fault still persists, replace rectifier I/O board. 4. If fault still persists, replace rectifier control board.

Table 10.8 – Fault Descriptions and Corrective Actions (Continued)(Frame 3)

Fault	No.	Type	Description	Action
Rctfr IT Overld	219	④	Short-term current rating of rectifier exceeded.	Low input voltage can result in increased current load. Provide proper input voltage to the drive.
Rctfr Not Login	238	④	Rectifier took too long to connect to inverter.	<ol style="list-style-type: none"> 1. Check the cabling between the communications interface and the two control boards. 2. Verify the DPI Data Rate (270) is set to 500K. 3. Connect one DPI device at a time to see if one of the DPI devices is causing the problem. 4. Replace the communications interface. 5. Replace the rectifier control board. 6. Swap 80W power supplies to see if fault follows supply. Replace power supply if needed.
Rctfr Not OK	232	④	A fault was detected on the rectifier but could not be displayed on the inverter.	<ol style="list-style-type: none"> 1. Look at rectifier parameter 243 to see fault code. 2. Check fuse at Line Sync PCB control transformer. Replace fuse if blown.
Rctfr Over Cur R,S,T	211 212 213	④	Rectifier overcurrent	<ol style="list-style-type: none"> 1. Verify proper motor data is entered on rectifier. 2. Reduce rectifier current limit using rectifier Current Limit parameter (105).
Rctfr Over Volt	224	④	The bus voltage is too high.	Monitor the AC line for high line voltage or transient conditions. Bus overvoltage can also be caused by motor regeneration. Extend the decel time or install dynamic brake option.
Rctfr Pwr Board	235	②	Drive rating information stored on the power board is incompatible with rectifier application firmware, or drive rating information stored on the power board was corrupted.	<ol style="list-style-type: none"> 1. Cycle power to the drive. 2. Load updated drive rating information onto rectifier. 3. Load updated rectifier application firmware. 4. Replace rectifier power board.

Table 10.8 – Fault Descriptions and Corrective Actions (Continued)(Frame 3)

Fault	No.	Type	Description	Action
Reactor Temp	214	④	Temperature switch in reactor opened.	Check for proper temperature and fan operation.
Replaced MCB-PB	107	②	Inverter control board or inverter power board was replaced.	1. Restore inverter defaults (parameter 197). 2. Reprogram parameters.
Ride Thru Abort	221	④	Input power loss timed out.	1. Verify input power and connections. 2. Check Line Sync board. 3. Check AC Line I/O board.
Shear Pin	63	③	Programmed Current Lmt Val (148) has been exceeded. Enabled/disable with Fault Config 1 (238).	Check load requirements and Current Lmt Val (148) setting.
SW OverCurrent	36	①	The drive output current has exceeded the software current.	Check for excess load, improper DC boost setting. DC brake volts set too high.
UnderVoltage	4	① ③	DC bus voltage fell below the minimum value of 407V DC at 400/480V input or 204V DC at 200/240V input. Enable/disable with Fault Config 1(233).	Monitor the incoming AC line for low voltage or power interruption.
UserSet1 Chksum	101	②	The checksum read from the user set does not match the checksum calculated.	Re-save user set.
UserSet2 Chksum	102	②		
UserSet3 Chksum	103	②		

10.4.3.2 Frame 4 Fault Descriptions and Corrective Actions

Table 10.9 describes drive faults and corrective actions for frame 4 (firmware version 2.x only). The table also indicates the fault type.

- ① Auto-resettable
- ② Non-resettable
- ③ User-configurable
- ④ Normal Fault*

*The fault is resettable using normal fault clearing mechanisms on the drive (Stop/Reset button, powercycling, etc.) or through V*S Utilities.

Table 10.9 – Fault Descriptions and Corrective Actions (Frame 4)

Fault	No.	Type	Description	Action
AC Line Lost	227	④	Input power Lost	<ol style="list-style-type: none"> 1. Verify proper input voltage. 2. Check rectifier parameters Input Voltage RS (7), Input Voltage ST (8), and Input Voltage TR (9). 3. Check fuse at control transformer. 4. Verify connections to the I/O board. 5. If fault persists, replace I/O board.
Analog In Loss	29	①	<p>An analog input is configured to fault on signal loss. A signal loss has occurred.</p> <p>Configure with Anlg In 1, 2 Loss (324, 327).</p>	<ol style="list-style-type: none"> 1. Check parameters. 2. Check for broken/loose connections at inputs.
Auto Rstrt Tries	33	③	<p>Drive unsuccessfully attempted to reset a fault and resume running for the programmed number of Auto Rstrt Tries (174).</p> <p>Enable/disable with Fault Config 1 (238).</p>	Correct the cause of the fault and manually clear.
AutoTune Aborted	80	④	The autotune procedure was canceled by the user.	Restart procedure.
Auxiliary Input	2	①	A user-configurable digital input is configured to "Aux. Fault" and the input is open.	<ol style="list-style-type: none"> 1. Check digital input wiring. 2. Configure the digital input to something else with inverter Digital In Sel parameter (361-366).

Table 10.9 – Fault Descriptions and Corrective Actions (Continued)(Frame 4)

Fault	No.	Type	Description	Action
Current Fbk Lost	35	④	The magnitude of motor current feedback was less than 5% Motor NP FLA (42) for the time configured in Imbalance Time (50). Detection of this fault is disabled when Imbalance Time (50) is set to the maximum value of 10.0 seconds.	<ol style="list-style-type: none"> 1. Verify connection of current feedback device and motor terminals. 2. If fault repeats, replace current feedback devices and/or power supply.
Decel Inhibit	24	③	The drive is not following a commanded deceleration because it is attempting to limit bus voltage.	<ol style="list-style-type: none"> 1. Verify input voltage is within drive specified limits. 2. Verify system ground impedance follows proper grounding techniques. 3. Disable bus regulation and/or add dynamic brake resistor and/or extend deceleration time.
Drive OverLoad	64	①	Drive rating of 110% for 1 minute or 150% for 3 seconds has been exceeded.	Reduce load or extend Accel Time (140).
Excessive Load	79	④	Motor did not come up to speed in the allotted time.	<ol style="list-style-type: none"> 1. Uncouple load from motor. 2. Repeat Autotune (61).
FluxAmpsRef Rang	78	④	The value for flux amps determined by the autotune procedure exceeds the programmed Motor NP FLA (42).	<ol style="list-style-type: none"> 1. Reprogram Motor NP FLA (42) with the correct motor nameplate value. 2. Repeat Autotune (61).
Ground Fault	13	①	A current path to earth ground in excess of 7% of drive rated amps has been detected at one or more of the drive output terminals.	Check the motor and external wiring to the drive output terminals for a grounded condition.
High AC Line	222	④	Input line voltage is too high.	Reduce input voltage to meet specification of $480 \pm 10\%$.
HW Fault	70	④	Inverter section of power structure hardware detected an unexpected fault during power stage diagnostics.	Replace power board.
HW OverCurrent	12	①	The drive output current has exceeded the hardware current limit.	Check programming. Check for excess load, improper DC boost setting, DC brake volts set too high or other causes of excess current.

Table 10.9 – Fault Descriptions and Corrective Actions (Continued)(Frame 4)

Fault	No.	Type	Description	Action
I/O Comm Loss	121	①	Communication between control board and I/O board has not been established.	<ol style="list-style-type: none"> 1. Clear fault. 2. If fault persists, verify connection between I/O board and control board. 3. If fault still persists, replace I/O board. 4. If fault still persists, replace control board.
Incompat MCB-PB	106	②	Drive rating information stored on the power board is incompatible with the Main Control board.	Load compatible version files into inverter.
Input I Imbalance	225	④	Input phase current imbalance exceeded limits.	Check for loose connection in input power wiring.
Input V Imbalance	226	④	Input voltage imbalance exceeded limits.	Check for problem in input power distribution.
Inv Temp Switch	31	④	The inverter over temperature switch opened.	Verify the connection between TB7-4 and TB7-5 on the I/O board.
Invtr Base Temp	8	①	Base temperature exceeded limit.	Check for proper temperature and flow rate of coolant.
Invtr Dsat U+, V+, W+	200 201 202	④	High current was detected in an IGBT.	<ol style="list-style-type: none"> 1. Check for loose connection in IGBT wire harness. 2. Check IGBTs.
Invtr Dsat U-, V-, W-	197 198 199	④	High current was detected in an IGBT.	<ol style="list-style-type: none"> 1. Check for loose connection in IGBT wire harness. 2. Check IGBTs.
Invtr Gate Kill	207	④	Gate kill contact is open.	Close gate kill contact.
Invtr HW Unk	230	④	Inverter section of power structure hardware reported unexpected fault.	<ol style="list-style-type: none"> 1. Verify connections between control board and power board. 2. If fault persists, replace power board. 3. If fault still persists, replace control board.
Invtr IGBT Temp	9	①	Output transistors have exceeded their maximum operating temperature.	Check for proper temperature and flow rate of coolant.
Invtr Over Cur U, V, W	203 204 205	④	High current was detected in an IGBT.	<ol style="list-style-type: none"> 1. Verify proper motor data is entered. 2. Reduce current limit.

Table 10.9 – Fault Descriptions and Corrective Actions (Continued)(Frame 4)

Fault	No.	Type	Description	Action
Invtr Unk IO Brd	123	①	The I/O board is of a type that is unknown to the inverter firmware. If fault is cleared, analog inputs and outputs will be unusable.	<ol style="list-style-type: none"> 1. Verify the I/O Board ID Voltage (354) is correct for this type of I/O board. 2. If ID voltage is not correct, then replace I/O board. If ID Voltage still isn't correct, then replace control board. 3. If ID voltage is correct, verify that current inverter application firmware version can use this type of I/O board. If not, then update inverter application firmware.
IR Volts Range	77	④	The drive autotuning default is Calculate, and the value calculated for IR Drop Volts is not in the range of acceptable values.	Re-enter motor nameplate data.
Ixo Voltage-Range	87	④	Ixo voltage calculated from motor nameplate data is too high.	<ol style="list-style-type: none"> 1. If Ixo calculation is not needed, disable it by clearing bit 2 of Compensation (inverter parameter 56), then clear fault. 2. If Ixo calculation is needed, re-enter motor nameplate data, and, if necessary, repeat Autotune (61).
Line Freq Lost	228	④	Line frequency not in the range of 47-63 Hz.	<ol style="list-style-type: none"> 1. Verify proper input voltage and frequency. 2. Verify connections to I/O board. 3. If fault persists, replace I/O board.
Low DC Bus	223	④	The bus voltage is too low.	Verify proper input voltage.
Motor I Imbalance	37	④	The motor current imbalance displayed in Imbalance Count (221) has exceeded Imbalance Limit (49) for time configured in Imbalance Time (50).	Clear fault.
Motor Overload	7	① ③	<p>Internal electronic overload trip.</p> <p>Enable/disable with Fault Config 1 (238).</p> <p>Overload threshold is set using inverter Motor OL Amps (48).</p>	An excessive motor load exists. Reduce load so drive output current does not exceed the current set by Motor NP FLA (42).

Table 10.9 – Fault Descriptions and Corrective Actions (Continued)(Frame 4)

Fault	No.	Type	Description	Action
Not at Voltage	237	④	The rectifier did not regulate to the desired voltage within the defined time.	<ol style="list-style-type: none"> 1. Check all fuses and cabinet wiring. 2. Replace I/O board. 3. Replace control board and/or power board.
NTC Demux Fail	30	④	Control board cannot read temperature information from inverter half of power board.	<ol style="list-style-type: none"> 1. Clear faults. 2. If fault persists, verify connections to power board. 3. If fault still persists, replace power board.
OverSpeed Limit	25	①	Functions such as slip compensation or bus regulation have attempted to add an output frequency adjustment greater than that programmed in Overspeed Limit (83).	Remove excessive load or overhauling conditions or increase Overspeed Limit (83).
OverVoltage	5	①	DC bus voltage exceeded maximum value.	Monitor the AC line for high line voltage or transient conditions. Bus overvoltage can also be caused by motor regeneration. Extend the decel time or install dynamic brake option.
Parameter Chksum	100	②	The calculated checksum does not match the stored checksum for parameter values read from the non-volatile memory.	<ol style="list-style-type: none"> 1. Restore inverter defaults using inverter Restore Defaults parameter (197). 2. Reload user set if used, or reprogram inverter parameters. 3. If fault recurs, replace control board.
Params Defaulted	48	④	The drive was commanded to write default values to all inverter parameters.	<ol style="list-style-type: none"> 1. Clear the fault or cycle power to the drive. 2. Program the inverter parameters as needed.
Phase U to Grnd	38	④	A phase-to-ground fault has been detected between the drive and motor in this phase.	<ol style="list-style-type: none"> 1. Check the wiring between the drive and motor. 2. Check motor for grounded phase.
Phase V to Grnd	39	④		
Phase W to Grnd	40	④		
Phase UV Short	41	④	Excessive current has been detected between these two output terminals.	<ol style="list-style-type: none"> 1. Check the motor and drive output terminal wiring for a shorted condition.
Phase VW Short	42	④		
Phase UW Short	43	④		

Table 10.9 – Fault Descriptions and Corrective Actions (Continued)(Frame 4)

Fault	No.	Type	Description	Action
Port 1-5 Adapter	71	④	The network card connected to DPI port stopped communicating. The fault code indicates the offending port number (71 = port 1, etc.)	<ol style="list-style-type: none"> 1. Check communication board for proper connection to external network. 2. Check external wiring to module on port. 3. Verify external network fault.
	72			
	73			
	74			
	75			
Port 1-5 DPI Loss	81	④	DPI port stopped communicating. An attached peripheral with control capabilities was removed. Fault 84 indicates specifically that the rectifier stopped communicating with the inverter.	<ol style="list-style-type: none"> 1. If DPI device was not intentionally disconnected, check wiring to the port. Replace wiring, port expander, peripherals, control board as required. 2. If fault 84 occurs, disconnect all external peripherals and cycle power to drive. If fault 84 recurs, replace control board.
	82			
	83			
	84			
	85			
Power Loss	3	① ③	DC bus voltage remained below 85% of nominal for longer than Power Loss Time (185). Enable/disable with Fault Config 1 (238).	Monitor the incoming AC line for low voltage or line power interruption.
Power Phased ACB	239	④	Input power is phased ACB rather than ABC.	Switch two of the input power phases.
Precharge Closed	233	④	Precharge was closed when it should be open.	<ol style="list-style-type: none"> 1. Check AUX contacts on precharge. 2. Check input bit 15 in rectifier parameter 216 to view status of input. 3. Check wiring.
Precharge Opened	234	④	Precharge was open when it should be closed.	<ol style="list-style-type: none"> 1. Check AUX contacts on precharge. 2. Check input bit 15 in rectifier parameter 216 to view status of input. 3. Check wiring.
Pwr Brd Chksum1	104	④	The checksum read from the EEPROM does not match the checksum calculated from the EEPROM data.	Clear the fault or cycle power to the drive.
Pwr Brd Chksum2	105	②	The checksum read from the board does not match the checksum calculated.	<ol style="list-style-type: none"> 1. Cycle power to the drive. 2. If problem persists, replace power board.
Rctfr Base Temp	217	④	Excessive rectifier temperature measured.	Check for proper temperature and flow rate of coolant.

Table 10.9 – Fault Descriptions and Corrective Actions (Continued)(Frame 4)

Fault	No.	Type	Description	Action
Rctfr Checksum	229	④	The parameter checksum read from the rectifier portion of the control board does not match the checksum calculated, or the control board or power board has been replaced.	<ol style="list-style-type: none"> 1. Clear fault. 2. If fault persists, restore defaults on rectifier (rectifier parameter 197), then reprogram rectifier parameters. 3. If fault still persists, replace control board or power board.
Rctfr DPI Comm	246	④	DPI communications interrupted between inverter and rectifier.	<ol style="list-style-type: none"> 1. Clear fault. 2. If fault recurs or persists, replace control board.
Rctfr Dsat R+, S+, T+	208 209 210	④	High current was detected in an IGBT.	<ol style="list-style-type: none"> 1. Check for loose connection in IGBT wire harness. 2. Check IGBTs.
Rctfr Dsat R-, S-, T-	241 242 243	④	High current was detected in an IGBT.	<ol style="list-style-type: none"> 1. Check for loose connection in IGBT wire harness. 2. Check IGBTs.
Rctfr Gate Kill	240	④	Gate kill contact is open.	Close gate kill contact.
Rctfr Gnd Fault	216	④	Excessive ground current measured.	Check for grounded input wiring.
Rctfr HW Unk	231	④	Rectifier portion of power structure hardware reported unexpected fault.	<ol style="list-style-type: none"> 1. Verify connections between control board and power board. 2. If fault persists, replace power board. 3. If fault still persists, replace control board.
Rctfr I2T Ovrld	220	④	Long-term current rating of rectifier exceeded.	Low input voltage can result in increased current load. Provide proper input voltage to the drive.
Rctfr IGBT Temp	218	④	Excessive calculated IGBT temperature.	Check for proper temperature and flow rate of coolant.
Rctfr I/O Board	236	④	Communication between control board and I/O board has not been established.	<ol style="list-style-type: none"> 1. Clear fault. 2. If fault persists, verify connection between I/O board and control board. 3. If fault still persists, replace I/O board. 4. If fault still persists, replace control board.
Rctfr IT Overld	219	④	Short-term current rating of rectifier exceeded.	Low input voltage can result in increased current load. Provide proper input voltage to the drive.

Table 10.9 – Fault Descriptions and Corrective Actions (Continued)(Frame 4)

Fault	No.	Type	Description	Action
Rctfr Not Login	238	④	Rectifier took too long to connect to inverter.	<ol style="list-style-type: none"> 1. Check the cabling between the communications interface and the two control boards. 2. Verify the DPI Data Rate (270) is set to 500K. 3. Connect one DPI device at a time to see if one of the DPI devices is causing the problem. 4. Replace the rectifier control board. 5. Swap 80W power supplies to see if fault follows supply. Replace power supply if needed.
Rctfr Not OK	232	④	A fault was detected on the rectifier but could not be displayed on the inverter.	<ol style="list-style-type: none"> 1. Look at rectifier parameter 243 to see fault code. 2. Check fuse at Line Sync PCB control transformer. Replace fuse if blown.
Rctfr NTC Demux	244	④	Control board cannot read temperature information from rectifier half of power board.	<ol style="list-style-type: none"> 1. Clear faults. 2. If fault persists, verify connections to power board. 3. If fault still persists, replace power board.
Rctfr Over Cur R, S, T	211 212 213	④	Rectifier overcurrent	<ol style="list-style-type: none"> 1. Verify proper motor data is entered on rectifier. 2. Reduce rectifier current limit using rectifier Current Limit parameter (105).
Rctfr Over Volt	224	④	The bus voltage is too high.	Monitor the AC line for high line voltage or transient conditions. Bus overvoltage can also be caused by motor regeneration. Extend the decel time or install dynamic brake option.
Rctfr Pwr Board	235	②	Drive rating information stored on the power board is incompatible with rectifier application firmware, or drive rating information stored on the power board was corrupted.	<ol style="list-style-type: none"> 1. Cycle power to the drive. 2. Load updated drive rating information onto rectifier. 3. Load updated rectifier application firmware. 4. Replace power board.

Table 10.9 – Fault Descriptions and Corrective Actions (Continued)(Frame 4)

Fault	No.	Type	Description	Action
Rctfr Unk IO Brd	245	④	The I/O board is of a type that is unknown to the rectifier firmware. If fault is cleared, analog inputs and outputs will be unusable.	<ol style="list-style-type: none"> 1. Verify that I/O Board ID Voltage (rectifier 354) is correct for this type of I/O board. 2. If ID voltage is not correct, then replace I/O board. If ID voltage is still not correct, then replace control board. 3. If ID voltage is correct, verify that current rectifier application firmware version can use this type of I/O board. If not, then update rectifier application firmware.
Reactor Temp	214	④	Temperature switch in reactor opened.	Check for proper temperature and fan operation.
Replaced MCB-PB	107	②	Control board or power board was replaced.	<ol style="list-style-type: none"> 1. Restore inverter defaults (parameter 197) 2. Reprogram parameters.
Ride Thru Abort	221	④	Input power loss timed out.	<ol style="list-style-type: none"> 1. Verify input power and connections. 2. Check I/O board.
Shear Pin	63	① ③	Programmed Current Lmt Val (148) has been exceeded. Enabled/disable with Fault Config 1 (238).	Check load requirements and Current Lmt Val (148) setting.
SW OverCurrent	36	①	The drive output current has exceeded the software current.	Check for excess load, improper DC boost setting. DC brake volts set too high.
UnderVoltage	4	① ③	DC bus voltage fell below the minimum value of 407V DC at 400/480V input or 204V DC at 200/240V input. Enable/disable with Fault Config 1(233).	Monitor the incoming AC line for low voltage or power interruption.
UserSet1 Chksum	101	②	The checksum read from the user set does not match the checksum calculated.	Re-save user set.
UserSet2 Chksum	102	②		
UserSet3 Chksum	103	②		

Table 10.10 – Fault Names Cross-Referenced by Fault Number

No. ¹	Fault	No. ¹	Fault	No. ¹	Fault
2	Auxiliary Input	77	IR Volts Range	216	Rctfr Gnd Fault
3	Power Loss	78	FluxAmpsRef Rang	217	Rctfr Base Temp
4	UnderVoltage	79	Excessive Load	218	Rctfr IGBT Temp
5	OverVoltage	80	AutoTune Aborted	219	Rctfr IT Overld
7	Motor Overload	81- 85	Port 1-5 DPI Loss	220	Rctfr I2T Overld
8	Invtr Base Temp	87	IXo VoltageRange	221	Ride Thru Abort
9	Invtr IGBT Temp	100	Parameter Chksum	222	High AC Line
12	HW OverCurrent	101	UserSet1 Chksum	223	Low DC Bus
13	Ground Fault	102	UserSet2 Chksum	224	Rctfr Over Volt
24	Decel Inhibit	103	UserSet3 Chksum	225	Input I Imbalance
25	OverSpeed Limit	104	Pwr Brd Chksum1	226	Input V Imbalance
29	Analog In Loss	105	Pwr Brd Chksum2	227	AC Line Lost
30	NTC Demux Fail ²	106	Incompat MCB-PB	228	Line Feq Lost
31	Inv Temp Switch ²	107	Replaced MCB-PB	229	Rctfr Checksum
33	Auto Rstrt Tries	120	I/O Mismatch ³	230	Invtr HW Unk
35	Current Fbk Lost	121	I/O Comm Loss	231	Rctfr HW Unk
36	SW OverCurrent	122	I/O Board Fail ³	232	Rctfr Not OK
37	Motor I Imbalance	123	Invtr Unk IO Brd ²	233	Precharge Closed
38	Phase U to Grnd	197-199	Invtr Dsat U-, V-, W- ²	234	Precharge Opened
39	Phase V to Grnd	200-202	Invtr Dsat U, V, W ³	235	Rctfr Pwr Board
40	Phase W to Grnd	200-202	Invtr Dsat U+, V+, W+ ²	236	Rctfr IO Board
41	Phase UV Short	203-205	Invtr Over Cur U, V, W	237	Not At Voltage
42	Phase VW Short	206	Invtr HW Unused ³	238	Rctfr Not Login
43	Phase WU Short	207	Invtr Gate Kill	239	Power Phased ACB
48	Params Defaulted	208-210	Rctfr Dsat R, S, T ³	240	Rctfr Gate Kill ²
63	Shear Pin	208-210	Rctfr Dsat R+, S+, T + ²	241-243	Rctfr Dsat R-, S-, T- ²
64	Drive Overload	211-213	Rctfr Over Cur R, S, T	244	Rctfr NTC Demux ²
70	HW Fault	214	Reactor Temp	245	Rctfr Unk IO Brd ²
71-75	Port 1-5 Adapter	215	Rctfr HW Unused ³	246	Rctfr DPI Comm ²

¹ Fault numbers not listed are reserved for future use.

² Fault available on Frame 4 drives only.

³ Fault available on Frame 3 drives only.

10.5 Diagnostic Parameters

Table 10.11 – Test Point Codes and Functions

Diagnostic Parameter Number	Value Displayed
1	DPI Error Status
2	IGBT Temperature
3	Active Current Limit
4	Active PWM Frequency
5	Lifetime MegaWatt Hours ¹
6	Lifetime Run Time
7	Lifetime Powered Up Time
8	Lifetime Power Cycles
9	Life MegaWatt Hours Fraction ¹
10	Life MegaWatt Hours Fraction Units ¹
11-99	Reserved for Factory Use

¹Use the equation below to calculate total Lifetime MegaWatt Hours.

$$\left(\left(\frac{\text{Value of Code 9}}{\text{Value of Code 10}} \times 0.1 \right) + \text{Value of Code 5} = \text{Total Lifetime Megawatt Hours} \right)$$

10.6 Common Symptoms and Corrective Actions

Table 10.12 – Drive Does Not Start From Start, Run, or Jog Inputs Wired to the Terminal Block

Indication(s)	Cause(s)	Corrective Action
Flashing red Ready LED.	Drive is faulted.	<p>Clear fault:</p> <ul style="list-style-type: none"> • Press OIM stop key. This action will only succeed if the clear faults function for that OIM is enabled using the Logic Mask (276) and Fault Clr Mask (283). • Cycle power. • Set Fault Clear (240) to 1. • Toggle terminal block stop or terminal block fault reset digital input. This action will only succeed if the clear faults function for that OIM is enabled using the Logic Mask (276) and Fault Clr Mask (283). • Cycle power.

Table 10.12 – Drive Does Not Start From Start, Run, or Jog Inputs Wired to the Terminal Block (Continued)

Indication(s)	Cause(s)	Corrective Action
Incorrect operation from the terminal block.	Incorrect input wiring. <ul style="list-style-type: none"> • 2-wire control requires Run, Run Forward, or Run Reverse input(s). • 3-wire control requires Start and Stop inputs • Jumper from terminal 7 to 8 is required. 	Wire inputs correctly and/or install jumper.
	Incorrect digital input programming. <ul style="list-style-type: none"> • Mutually exclusive choices have been made. • 2-wire and 3-wire programming may be conflicting. • Exclusive functions (i.e, direction control) may have multiple inputs configured. • Stop if factory default and is not wired or is open. • Start or Run programming may be missing. 	Program Digital In"x" Sel (361-366) for correct inputs.
	The Digital In bit of one or more of the mask parameters (276-285) is not set.	Set the Digital In bit to 1 in the appropriate mask parameters (276-285). The Digital In bit of the Logic Mask (276) must be set if any control function is to be performed from the terminal block.

Table 10.12 – Drive Does Not Start From Start, Run, or Jog Inputs Wired to the Terminal Block (Continued)

Indication(s)	Cause(s)	Corrective Action
Flashing yellow Ready LED and DigIn CflctB indication on LCD OIM. Drive Status 2 (210) shows type 2 alarm(s).	<p>Incorrect digital input programming.</p> <ul style="list-style-type: none"> • Mutually exclusive choices have been made. • 2-wire and 3-wire programming may be conflicting. • Exclusive functions (i.e, direction control) may have multiple inputs configured. • Stop if factory default and is not wired or is open. • Start or Run programming may be missing. 	<p>Program Digital In"x" Sel (361-366) to resolve conflicts.</p> <p>Remove multiple selections for the same function.</p> <p>Install stop button to apply a signal at stop terminal.</p>

Table 10.13 – Drive Does Not Start or Jog From OIM

Indication	Cause(s)	Corrective Action
None	Drive is programmed for 2-wire control, and the bits of the Logic Mask (276) and Start Mask (277) that apply to the OIM are set to 1.	<p>If 2-wire control is required, no action is necessary.</p> <p>If 3-wire control is required, program Digital Inx Sel (361-366) for correct inputs.</p>
Flashing or steady red Ready LED.	Active fault.	Reset fault.
Flashing yellow Ready LED.	Enable input is open.	Close terminal block enable input.
	The terminal block stop input is open.	Close terminal block stop input.
	Start inhibit bits are set.	Check status in Start Inhibits (214).

Table 10.14 – Drive Does Not Respond to Changes in Speed Command

Indication	Cause(s)	Corrective Action
LCD OIM Status Line indicates “At Speed” and output is 0 Hz.	No value is coming from the source of the command.	<ol style="list-style-type: none"> 1. If the source is an analog input, check wiring and use a meter to check for presence of signal. 2. Check Commanded Freq (2) for correct source.
None	Incorrect reference source has been programmed.	<ol style="list-style-type: none"> 1. Check Speed Ref Source (213) for the source of the speed reference. 2. Reprogram Speed Ref A Sel (90) for correct source.
None	Incorrect reference source is being selected via remote device or digital inputs.	<ol style="list-style-type: none"> 1. Check Drive Status 1 (209), bits 12 - 15 for unexpected source selections. 2. Check Dig In Status (216) to see if inputs are selecting an alternate source. 3. Reprogram digital inputs to correct Speed Sel x option.

Table 10.15 – Motor and/or Drive Will Not Accelerate to Commanded Speed

Indication	Cause(s)	Corrective Action
Acceleration time is excessive.	Incorrect value in Accel Time “x” (140, 141).	Reprogram Accel Time “x” (140, 141).
Drive is forced into current limit, slowing or stopping acceleration.	Excess load or short acceleration time.	<p>Check Drive Status 2 (210), bit 10 to see if the drive is in current limit.</p> <p>Remove excess load or reprogram Accel Time “x” (140, 141).</p>
Speed command source or value is not as expected.	Improper speed command.	Check for the proper speed command using steps 1 through 7 in table 10.14.
Programming is preventing the drive output from exceeding limiting values.	Incorrect programming.	Check Maximum Speed (82) and Maximum Freq (55) to insure that speed is not limited by programming.

Table 10.16 – Motor Operation is Unstable

Indication	Cause(s)	Corrective Action
None	Motor data was incorrectly entered or autotune was not performed.	<ol style="list-style-type: none"> 1. Correctly enter motor nameplate data. 2. Perform static or rotate autotune procedure (61).

Table 10.17 – Drive Will Not Reverse Motor Direction

Indication	Cause(s)	Corrective Action
None	Digital input is not selected for reversing control.	Check Digital In"x" Sel. Choose correct input and program for reverse.
	Digital input is incorrectly wired.	Check input wiring.
	Direction Mode (190) parameter is incorrectly programmed.	Reprogram Direction Mode (190) for analog bipolar or digital unipolar control.
	Motor wiring is improperly phased for reverse.	Switch two motor leads.
	A bipolar analog speed command input is incorrectly wired or signal is absent.	<ol style="list-style-type: none"> 1. Use meter to check that an analog input voltage is present. 2. Check wiring. Positive voltage commands forward direction. Negative voltage commands reverse direction.

Table 10.18 – Stopping the Drive Results in a Decel Inhibit Fault

Indication	Cause(s)	Corrective Action
Decel Inhibit fault screen. LCD status line indicates Faulted.	The bus regulation feature is enabled and is halting deceleration due to excessive bus voltage. Excess bus voltage is normally due to excessive regenerated energy or unstable AC line input voltages. Internal timer has halted drive operation.	<ol style="list-style-type: none"> 1. Reprogram bus regulation (parameters 161 and 162) to eliminate any Adjust Freq selection. 2. Disable bus regulation (parameters 161 and 162) and add a dynamic brake. 3. Correct AC input line instability or add an isolation transformer. 4. Reset drive.

10.7 Replacement Parts

Tables 10.19 and 10.22 list the replacement parts that are available from Reliance Electric. Order replacement part by kit number, when listed. See figures 2.2 - 2.7 for parts locations.

Table 10.19 – LiquiFlo 2.0 Drive Replacement Parts (Frame 3 Only)

Description	Part Number / Kit Number	Quantity	
		180264-Axx	180264-Axx
AC Contactor - 140 A, 120 V	A-B # 100-140D11	3	3
AC Contactor (surge suppressor) 110V, 127V	A-B # 100-DFSC110	3	3
Capacitor Bank Assembly	179922-Q03	1	-
	179922-Q01	-	1
Line Sync. PC Board Assembly	179646 / 180043	1	1
Line Sync. Board Cover	179723	1	1
Fuse Block, 30 A, 600 V, Class CC, 2-Line	49454-19B	1	1
Fuse Block, 30 A, 600 V, Class CC, 3-Line	49454-19C	2	2
Lug, 2-600 MCM	Thomas & Betts # ADR60-22D	1	1
115 V Fan, 6" dia.	69739-20R	2	2
Transformer, 3 KVA	179930	1	1
Fuse Holder, 600 V, 30 A	Buss # R60030-2SR	1	1
Precharge Resistor, 10 Ohm, 300W	422302-1C	3	3
Resistor, 100 kOhm, 50 W	Dale # RH-50	3	3
Circuit Breaker	Square D # MHL366006139	1	-
	Square D # MHL368006139	-	1
Fuse, Class RK-5, 600 V, 15 A	Gould/Shawmut # TRS-R15	2	2
Fuse, Class CC, 600 V, 5 A	Gould/Shawmut # ATQR5	1	1
Fuse, Class CC, 600 V, 1 A	Gould/Shawmut # ATQR1	3	3
Fuse, Class CC, 600 V, 20 A	Gould/Shawmut # ATDR20	3	3
Fuse, Class CC, 600 V, 25 A	Gould/Shawmut # ATQR25	1	1
Terminal Block, 6-Position	49455-93E	1	1
Capacitor Guard Panel	179960	1	1
Plastic Knob	Reid # JCL-555	4	4
115 V Fan, 5" sq.	195008-Q01	1	1
Operating Mechanism, Complete Kit	Square D # 9421 LT-4	1	1
460 A Power Module	LF200460AAx	1	-
608 A Power Module	LF200608CCx	-	1
LCD OIM, Door-Mounted	RE1LCD	1	1
	REBZL-N1	1	1
Air Filter	180415	1	1
Floor Mounting Kit (Optional)	180380-Q01	3	3

Table 10.20 – LiquiFlo 2.0 Power Module Replacement Parts (Frame 3 Only)

Description	Part Number / Kit Number	Quantity	
		LF200460AAP	LF200608CCR
Wire Harness Assembly, Line Sync.	179713-Q01	1	1
Wire Harness Assembly, DC Bus Bleeder Resistors	179743-Q02	1	1
Wire Harness Assembly, Gate Driver, Rectifier Side	180427-Q01	1	1
Wire Harness Assembly, Gate Driver, Inverter Side	180427-Q02	1	1
Current Feedback Device, 1000 A	179701	6	6
Wire Harness Assembly, Current Feedback Device	179711	1	1
Rectifier Control Assembly	179985-A02 / 180063-A01	1	1
AC Line I/O Assembly	179565 / 180090-A01	1	1
Inverter Control Assembly	179986-A02 / 180064-A01	1	1
Connector, Terminal Block, 32-pin	191800	2	2
Internal Fan	179196	1	1
Rectifier Power Interface Assembly, 440A, (2) 300 A Modules 608A, (2) 450 A Modules	180147 / 180069-A04 180154 / 180069-A05	1 -	- 1
Inverter Power Interface Assembly, 460A, (2) 300 A Modules 608A, (2) 450 A Modules	180148 / 180088-A04 179717 / 180088-A01	1 -	- 1
Insulation Sheet	179700	2	2
80 W Power Supply Assembly	193087-A02 / 180089-A01	2	2
Terminal Block, 2-position	179745	2	2
Wire Harness Assembly, Power Supply, Upper Gate	179710	2	2
Wire Harness Assembly, Power Supply, Logic	179753	2	2
Wire Harness Assembly, Power Supply, Lower Gate	179754	1	1
Communications Interface Assembly	179571 / 180062-A01	1	1
Cable Assembly, 30-pin	179694-Q01	2	2
Cable Assembly, 40-pin	179828-Q01	2	2
Standard I/O Option, 24V Assembly	314891-A01 / 180060-A01	1	-

Table 10.21 – LiquiFlo 2.0 Drive Replacement Parts (Frame 4 Only)

Description	Part Number / Kit Number	Quantity	
		180580-A07	180580-A09
AC Contactor - 300 A, 600 V	A-B # 100-D300ED11	3	3
Capacitor Bank Assembly	180205-A02 180205-A01	1 -	- 1
Control Terminal Block Assembly	180974-A01	1	1
Fuse Block, 30 A, 600 V, Class CC, 2-Line	49454-19B	1	1
Fuse Block, 30 A, 600 V, Class CC, 3-Line	17719	2	2
Lug, 2-600 MCM	Thomas & Betts # ADR60-22D	1	1
115 V Fan	69739-20R	5	5
Transformer, 3 KVA	180086	1	1
Fuse Holder, 600 V, 30 A	Buss # R60030-2SR	1	1
Precharge Resistor, 10 ohm, 300 W	422302-1C	6	6
Resistor, 100 kOhm, 50 W	Dale # RH-50	6	6
Circuit Breaker	807300-293 E 807300-293 D	1 -	- 1
Fuse, Class RK-5, 600 V, 10 A	Gould/Shawmut # TRS-R10	2	2
Fuse, Class CC, 600 V, 10 A	Gould/Shawmut # ATQR10	1	1
Fuse, Class CC, 600 V, 1 A	Gould/Shawmut # ATQR1	3	3
Fuse, Class CC, 600 V, 20 A	Gould/Shawmut # ATDR20	3	3
Fuse, Class CC, 600 V, 25 A	Gould/Shawmut # ATQR25	1	1
Terminal Block, 4-Position	49455-93C	2	2
Capacitor Guard Panel	180209	1	1
Operating Mechanism, Complete Kit	180465-Q01	1	1
1215 A Power Module	LF201215CCP	1	1

Table 10.22 – LiquiFlo 2.0 Power Module Replacement Parts (Frame 4 Only)

Description	Part Number / Kit Number	Quantity
		LF201215CCR
Combined Power PCB Assembly, 810 Amps	180288-A02 / 180323-A02	0
Combined Power PCB Assembly, 1215 Amps	180288-A01 / 180323-A01	1
Wire Harness Assembly, Gate Driver	180314-Q01	2
Internal Fan, 24 VDC	191673-Q02	1
Internal Fan, 24 VDC	69739-48A	2
Wire Harness Assembly, Internal Fan	180316-Q01	1
Wire Harness Assembly, DC Power	180307-Q01	1
Wire Harness Assembly, DC Bus Resistors	180315-Q01	1
Current Feedback Device, 2000 A	179757-Q01	6
Wire Harness Assembly, Current Feedback Device, Rectifier Side	180313-Q01	1
Wire Harness Assembly, Current Feedback Device, Inverter Side	180313-Q02	1
Wire Harness Assembly, RTD, Rectifier Side	180452-Q01	1
Wire Harness Assembly, RTD, Inverter Side	180452-Q02	1
Cable Assembly, 40-Pin	179828-Q01	2
Combined Control PCB Assembly	180464-A01 / 180325-A01	1
Combined I/O PCB Assembly	180284-A01 / 180370-A01	1
Cable, Mini DIN, 8 Pos., Male/Male, 1 Meter Long	22105-134-01	1
Chillplate RM Assembly	180037-A02	2

10.8 Troubleshooting the Drive Using the LCD OIM

The LCD OIM provides immediate visual notification of alarm or fault conditions as well as the following diagnostic information:

- Entries in the fault queue
- Fault parameters
- Drive status parameters
- Selected device version and status information
- OIM version information

10.8.1 Accessing the Fault Queue

As described in section 10.4.1, the drive automatically retains a history of the last four faults that have occurred in the fault queue.

To access the fault queue, press the F4 key at the process display screen, or see figure 10.6 to access the fault queue from the Main Menu.

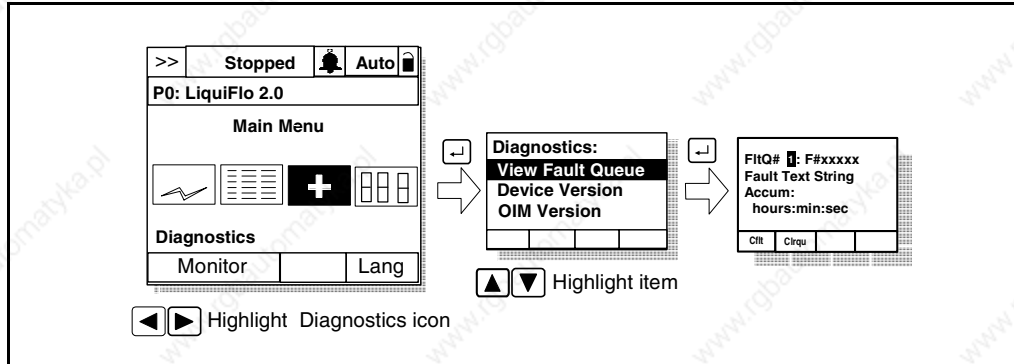

Figure 10.6 – Accessing the Fault Queue

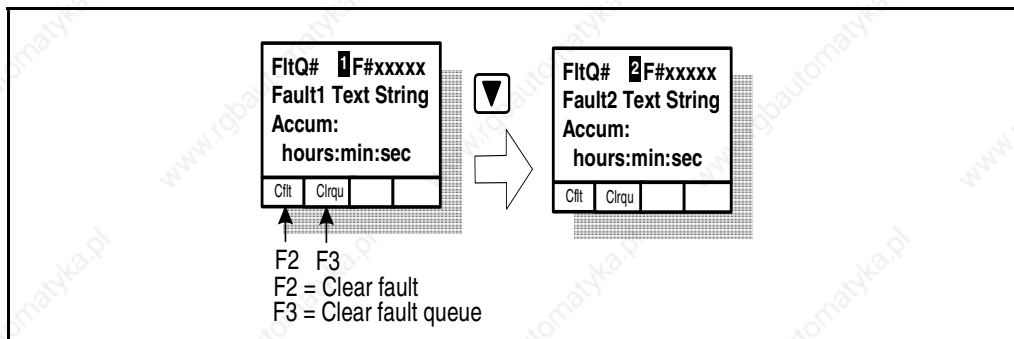

Figure 10.7 – Sample Fault Queue Entry

10.8.2 Accessing the Fault Parameters

The LCD OIM provides quick access to the drive's fault parameters by grouping them in the Fault Info submenu. To access these parameters, see figure 10.8.

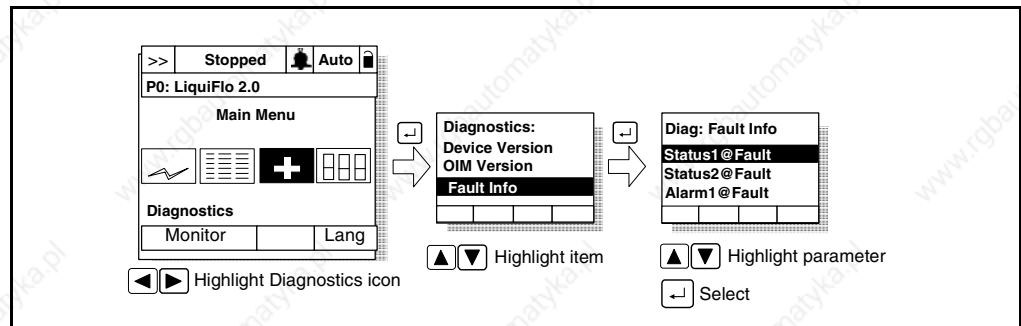

Figure 10.8 – Accessing the Fault Parameters

10.8.3 Accessing the Drive Status Parameters

The LCD OIM provides quick access to the drive status parameters by grouping them in the Status Info submenu. To access these parameters, see figure 10.9.

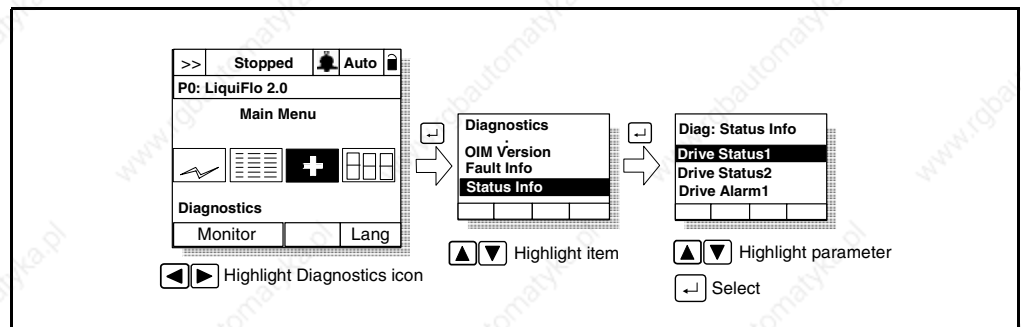

Figure 10.9 – Accessing the Drive Status Parameters

10.8.4 Determining the Product Version

The LCD OIM can be used to determine hardware and firmware version information for the drive and for connected devices, including the OIM, down to the component level.

Section 10.8.4.1 provides a general procedure for determining device version information for a device, where the “device” is the inverter, the rectifier, or a DPI peripheral device. In order to use this procedure, the LCD OIM must first be set to view information for the device of interest. See section 9.3.1 for information on setting up the LCD OIM so that it is displaying information related to a particular device.

10.8.4.1 Device Version

To access the device version information for the current device (inverter, rectifier, or DPI peripheral device), refer to figures 10.10 and 10.11. This example assumes that the LCD OIM is currently viewing the inverter device, indicated by “P0: LiquiFlo 2.0” on the LCD OIM display. If the LCD OIM were currently viewing the rectifier device, the LCD OIM display would contain the line “P2: Active Rectifier.”

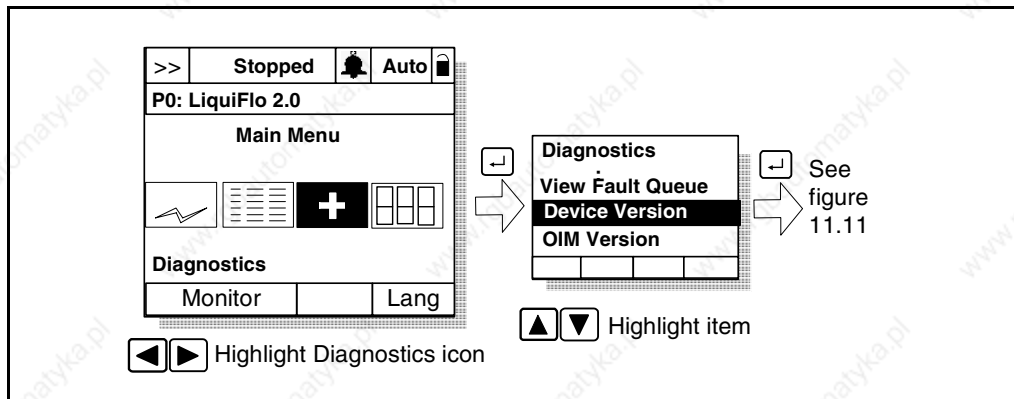

Figure 10.10 – Accessing the Device Version Information

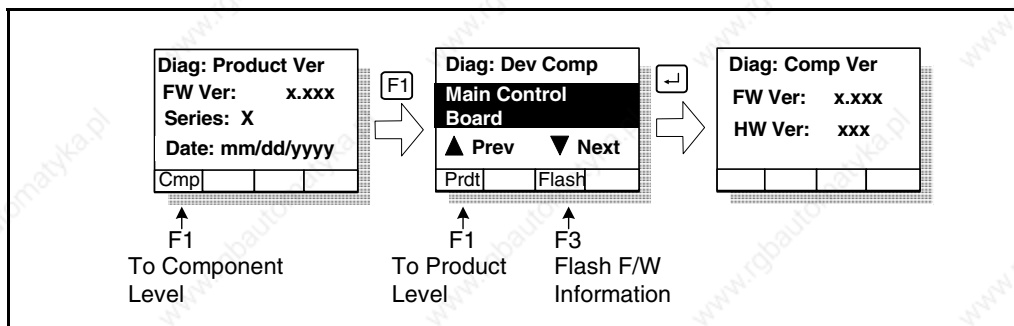

Figure 10.11 – Device Version Screens at Product and Component Levels

10.8.4.2 OIM Version

The OIM Version selection provides information on the OIM you are using to access this data. See figures 10.12 and 10.13.

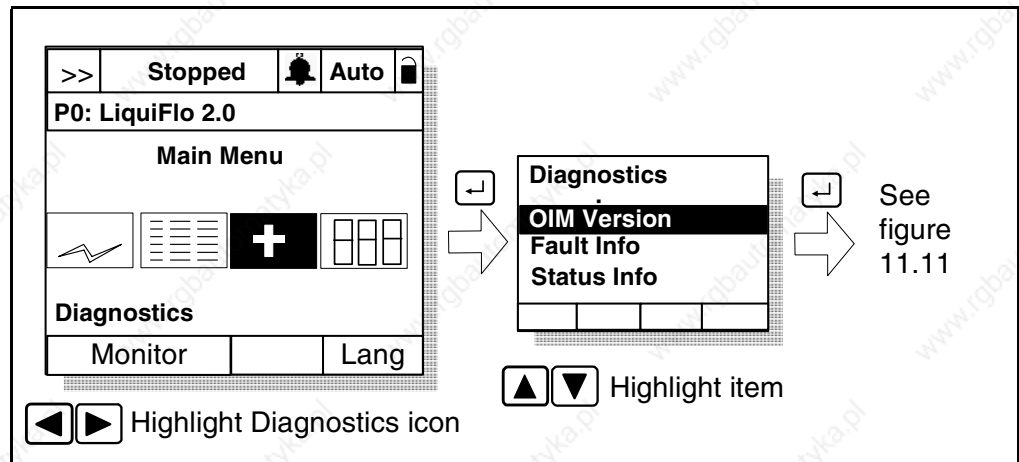

Figure 10.12 – Accessing the OIM Version Information

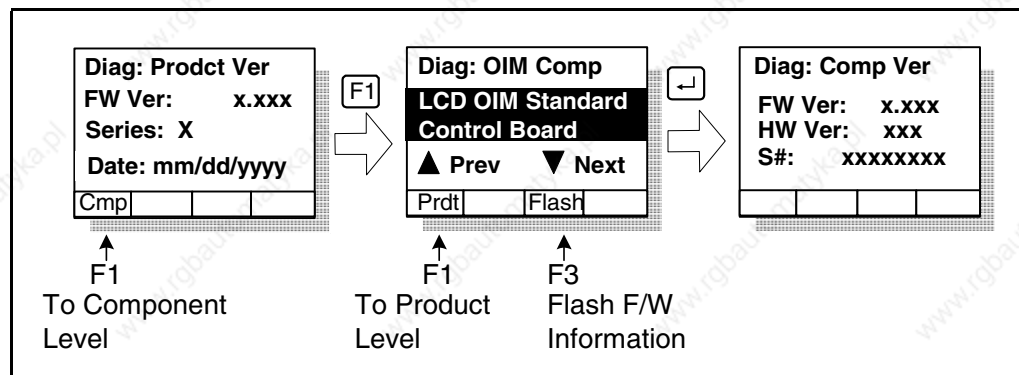

Figure 10.13 – OIM Version Screens at the Product and Component Levels

10.8.4.3 Device Items

The Device Items selection provides access to a list of diagnostic parameters. These parameters should be adjusted by qualified personnel only. See figure 10.14.

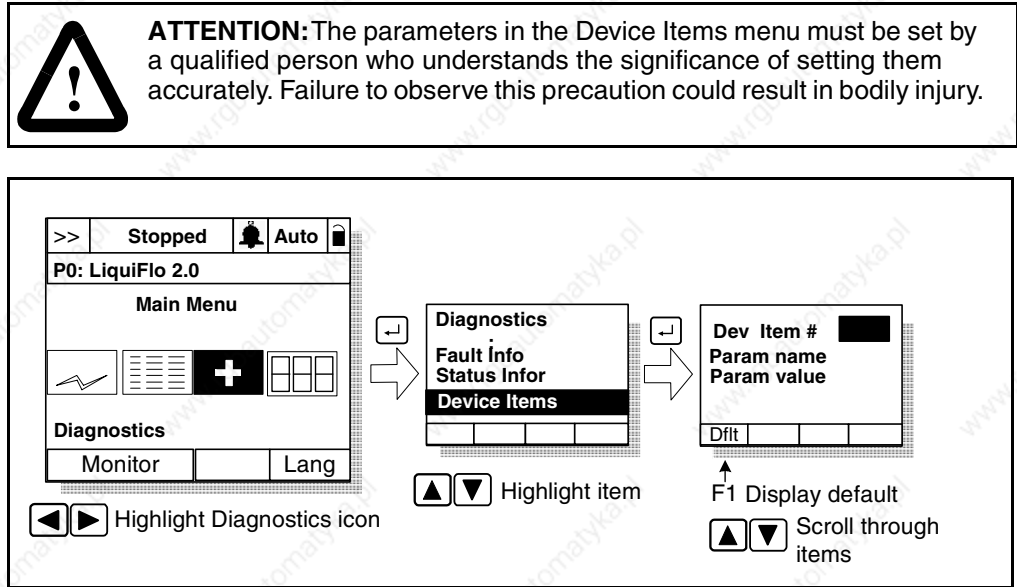

Figure 10.14 – Accessing the Device Item Information

10.8.5 Contacting Tech Support for Assistance

The Tech Support option in the Diagnostics menu provides information regarding technical support.

APPENDIX A

Technical Specifications

Table A.1 – Service Conditions

AC Line Distribution System Capacity (maximum) for 480 VAC Units	100,000 amps symmetrical fault current capacity. Short circuit rating may be limited to 65,000 amps if a circuit breaker is used instead of fuses.
Control Method	Sinusoidal pulse-width-modulated (PWM)
Displacement Power Factor	≥0.99
Line Frequency	50/60 Hz (±2 Hz)
Line Voltage Variation	-10% to +10%
Motor Lead Lengths	76 meters (250 feet) total
Remote Operator Control Wire Length	Up to 1 meter (3 feet) from the drive
Analog Speed Reference Resolution	1/4096 (12 bits) 0.025%
Acceleration Adjustment Range	0.1 to 100.0 seconds (within the ability of current)
Inverter PWM Frequency (151)	2 kHz, 3 kHz, or 4 kHz (software-selectable)
Current Limit Adjustment	25% to 150% of drive rated amps
Service Factor	1.0
Speed Adjustable Range	From 0 Hz to maximum speed
Speed Regulation	Motor slip dependent
Speed Reference Resolution	0.01 with OIM, ±32767 counts with a network reference
Assembly Max Air Heat Load (Heat dissipated into surrounding air)	<ul style="list-style-type: none"> • LF2 480VAC Input, 405A output = 1800 W • LF2 480VAC Input, 608A output = 2700 W • LF2 480VAC Input, 1215 output, 5300 W

Table A.2 – Environmental Conditions

Condition	Specification
Operating Temperature (outside enclosure)	0°C to 40°C (32°F to 104°F)
Storage Temperature (Ambient)	-40°C to 65°C (-40°F to 149°F)
Humidity	5% to 95% (non-condensing)

Table A.3 – Cooling System Specifications

	LF200460AAR	LF200608CCR	LF201215CCR	LF201215CCR
Max. Input Current (Amps)	405	608	810	1215
Max. Output Current (Amps)	405	608	810	1215
Coolant Temp Range* (°C)	5 - 40	5 - 40	5 - 40	5 - 40
Minimum Coolant Flow Rate (GPM)	7	7	15	15
Pressure Drop (psig) from Power Module Inlet to Outlet @ Min. Coolant Flow Rate	10	10	10	10
Coolant	WEG25**	WEG25**	WEG25**	WEG25**
Max. Inlet Pressure (PSI)	180	180	180	180
Max. Heat Load	6000 Watts	9000 Watts	12,000 Watts	18,000 Watts

*Coolant temperature must be above the dew point to prevent condensation. If the water temperature is below the dew point, the appropriate water flow rate control is needed. Consult Rockwell Automation.

**WEG25 = good quality or distilled water/ethylene glycol 25% by volume. An approved inhibited, silicate-free ethylene glycol is Ucartherm, a product of Dow Chemical Company.

	<p>ATTENTION: Ethylene glycol solutions must be inhibited and silicate-free. Use of uninhibited and silicate-containing solutions can damage the cooling system.</p>
--	---

For coolant hardware connections, refer to the notes for figure 3.2.

APPENDIX B

Using the LCD OIM

The LCD Operator Interface Module (OIM) is an optional keypad/display that enables you to program, monitor, and control the drive.

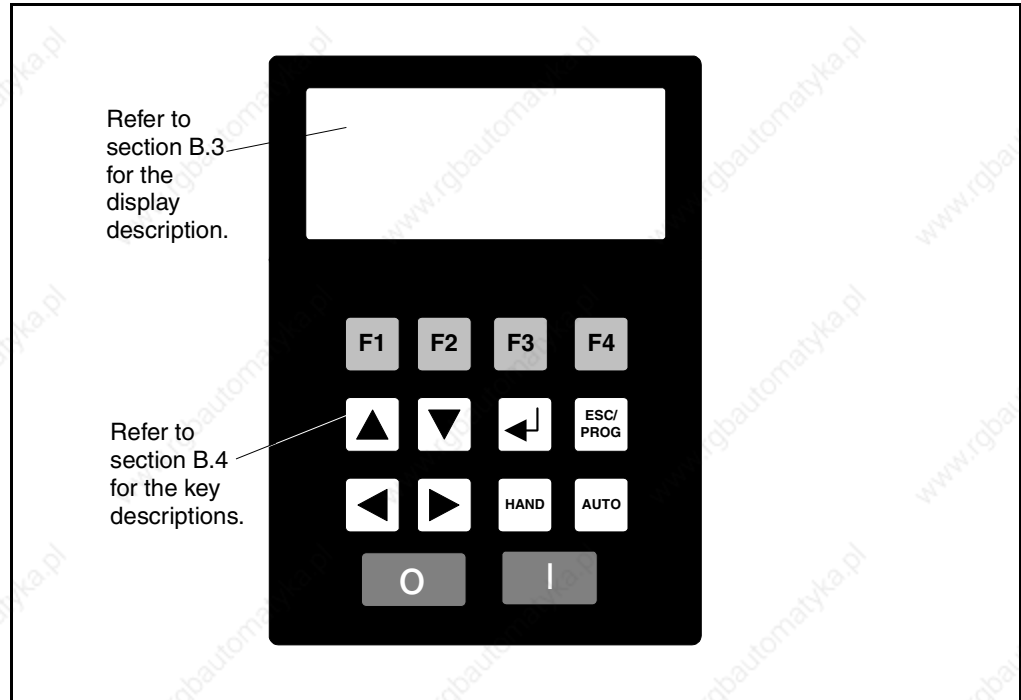

Figure B.1 – LCD OIM

B.1 Installing and Removing the LCD OIM

A cable (RECBL-LCD) must be used to convert the OIM for hand-held use. The maximum cable length is 32 feet using extender cables.

To **install** the LCD OIM on a Frame 3 Power Module, connect the OIM to DPI port 3 on the DPI Communication Interface board until it clicks into place. See figure B.2.

To **install** the LCD OIM on a Frame 4 Power Module, connect the OIM to the OIM adapter on the lower right corner of the power module. See figure B.3.

To **remove** the LCD OIM, pull back on the OIM cable connector to release the OIM from the DPI Communication Interface board.

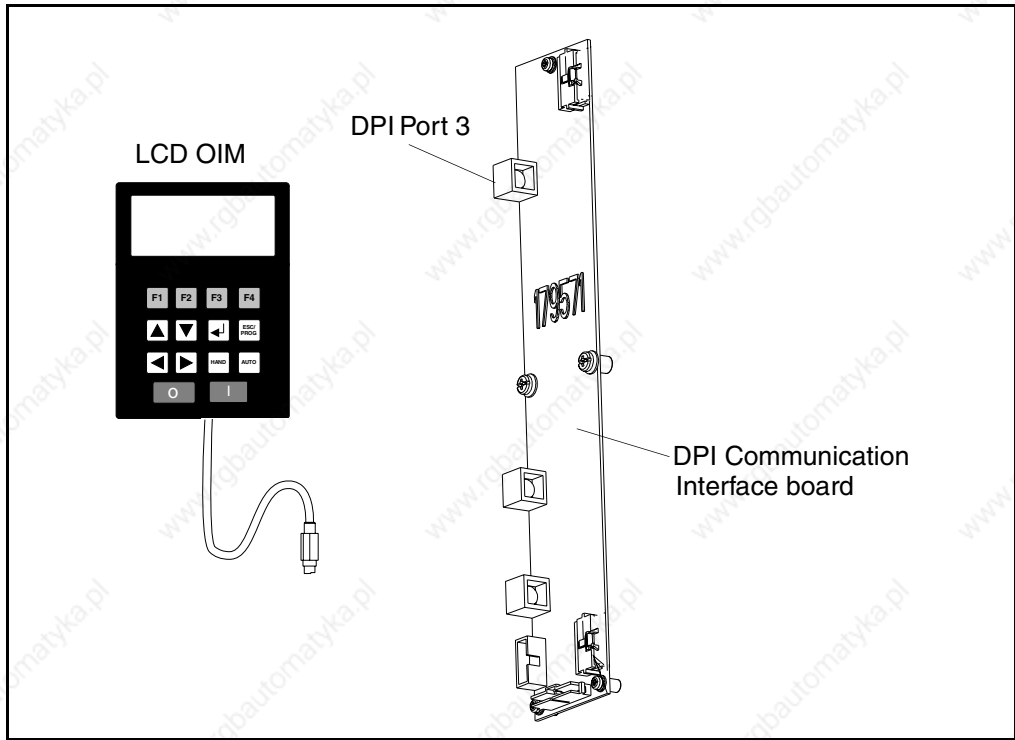

Figure B.2 – Installing and Removing the Local LCD OIM (Frame 3)

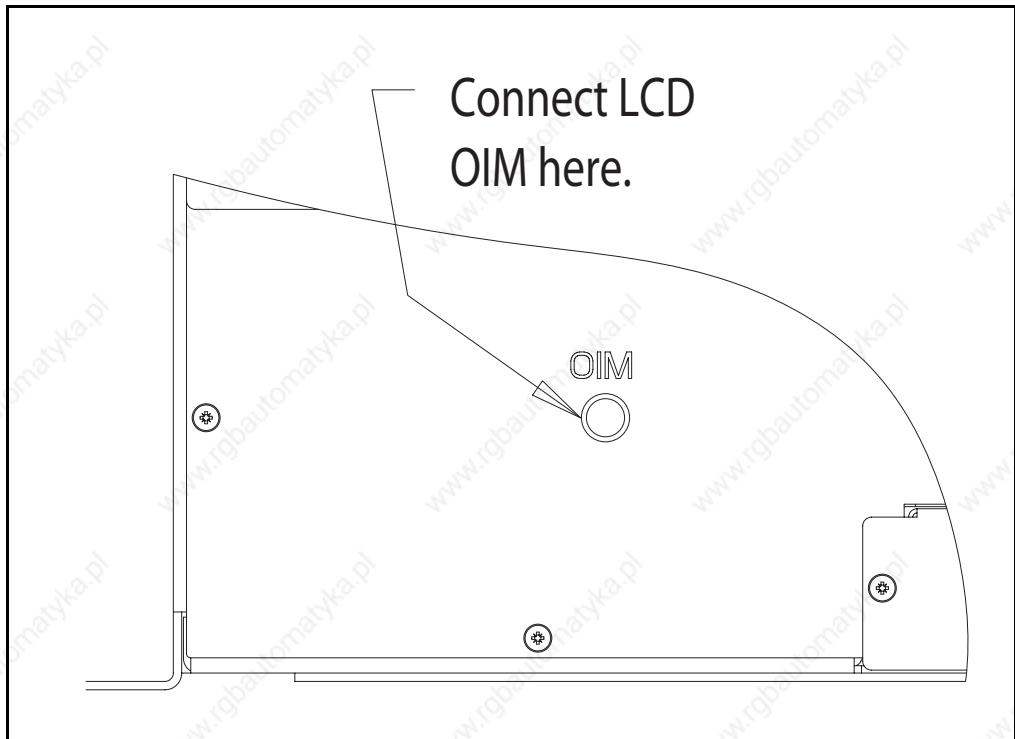

Figure B.3 – Installing and Removing the Local LCD OIM (Frame 4)

B.1.1 Removing the LCD OIM While the Drive is Powered

If the LCD OIM is the selected control source, removing the OIM while the drive is powered will cause a drive fault.

If the LCD OIM is not the selected control source, but is the reference source, removing the OIM while the drive is powered will result in a zero reference value. When the OIM is replaced, the drive will ramp to the reference level supplied by the OIM.



ATTENTION: Removing and replacing the LCD OIM while the drive is running may cause an abrupt speed change if the LCD OIM is the selected reference source, but is not the selected control source. The drive will ramp to the reference level provided by the OIM at the rate specified in Accel Time 1 (140), Accel Time 2 (141), Decel Time 1 (142) and Decel Time 2 (143). Be aware that an abrupt speed change may occur depending upon the new reference level and the rate specified in these parameters. Failure to observe this precaution could result in bodily injury.

If the LCD OIM is not the selected control source or reference source, removing the OIM while the drive is powered will have no effect on drive operation.

B.2 Display Description

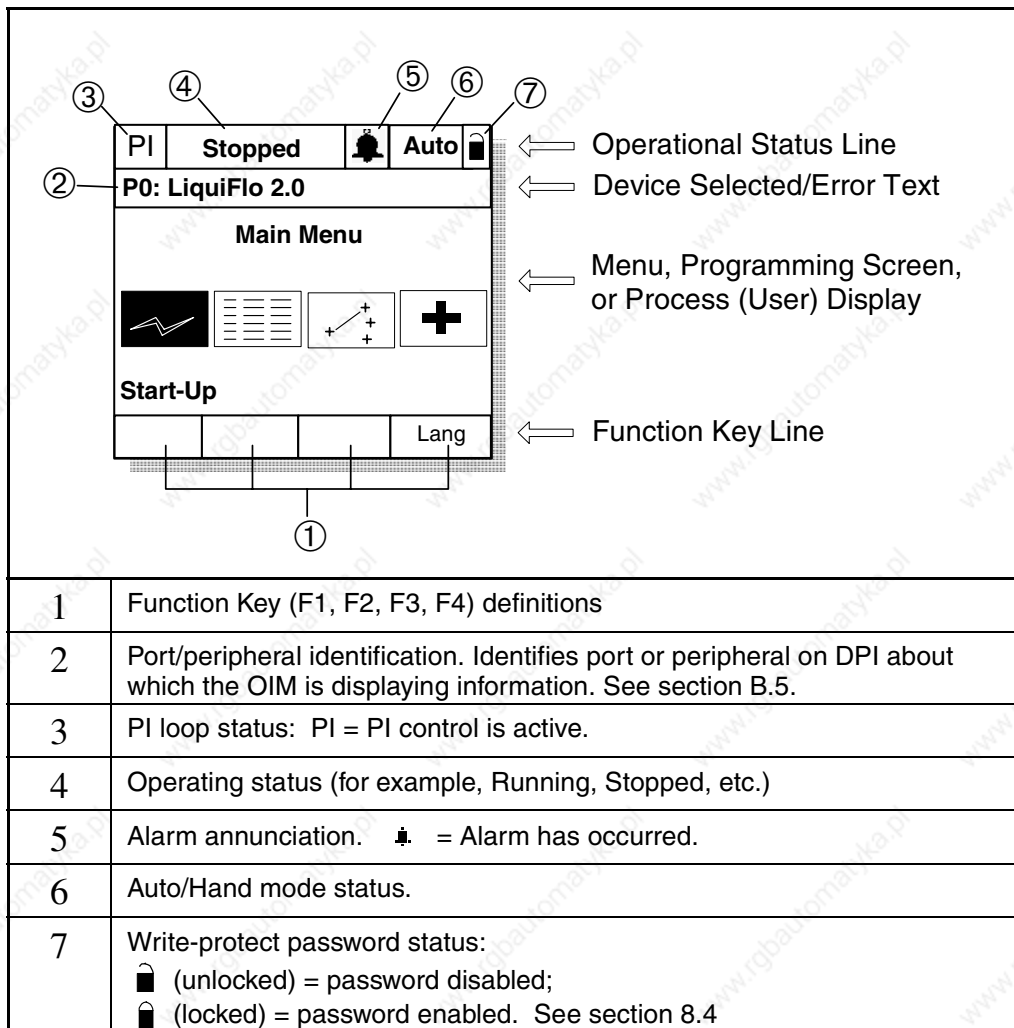













Figure B.4 – The Display (Main Menu Shown)

B.2.1 Key Descriptions

Table B.1 – Key Functions

Key	Function
	Scroll through options or user function keys, move cursor to the left.
	Scroll through options or user functions keys, move cursor to the right.
	Scroll through options, increase a value, or toggle a bit.
	Scroll through options, decrease a value, or toggle a bit.
	Exit a menu, cancel a change to a parameter, or toggle between program and process (user) display screens.
	Enter a menu, select an option, or save changes to parameter value
	Enable Hand (manual) reference control.
	Release Hand (manual) reference control.
	Stop the drive. Clear a fault if the OIM is the control source.
	Start the drive if the OIM is the control source.
	F1 though F4: Predefined or user-configured functions. The definition of each key is shown directly above the key on the display. See item ① in figure B.4.



ATTENTION:When switching from Auto to Hand, or Hand to Auto, the drive will ramp to the reference level provided by the new source at the rate specified in Accel Time 1 (140), Decel Time 1 (142), Accel Time 2 (141), or Decel Time 2 (143). Be aware that an abrupt speed change may occur depending upon the new reference level and rate specified in these parameters. Failure to observe this precaution could result in bodily injury.

B.3 LCD OIM Menu Structure

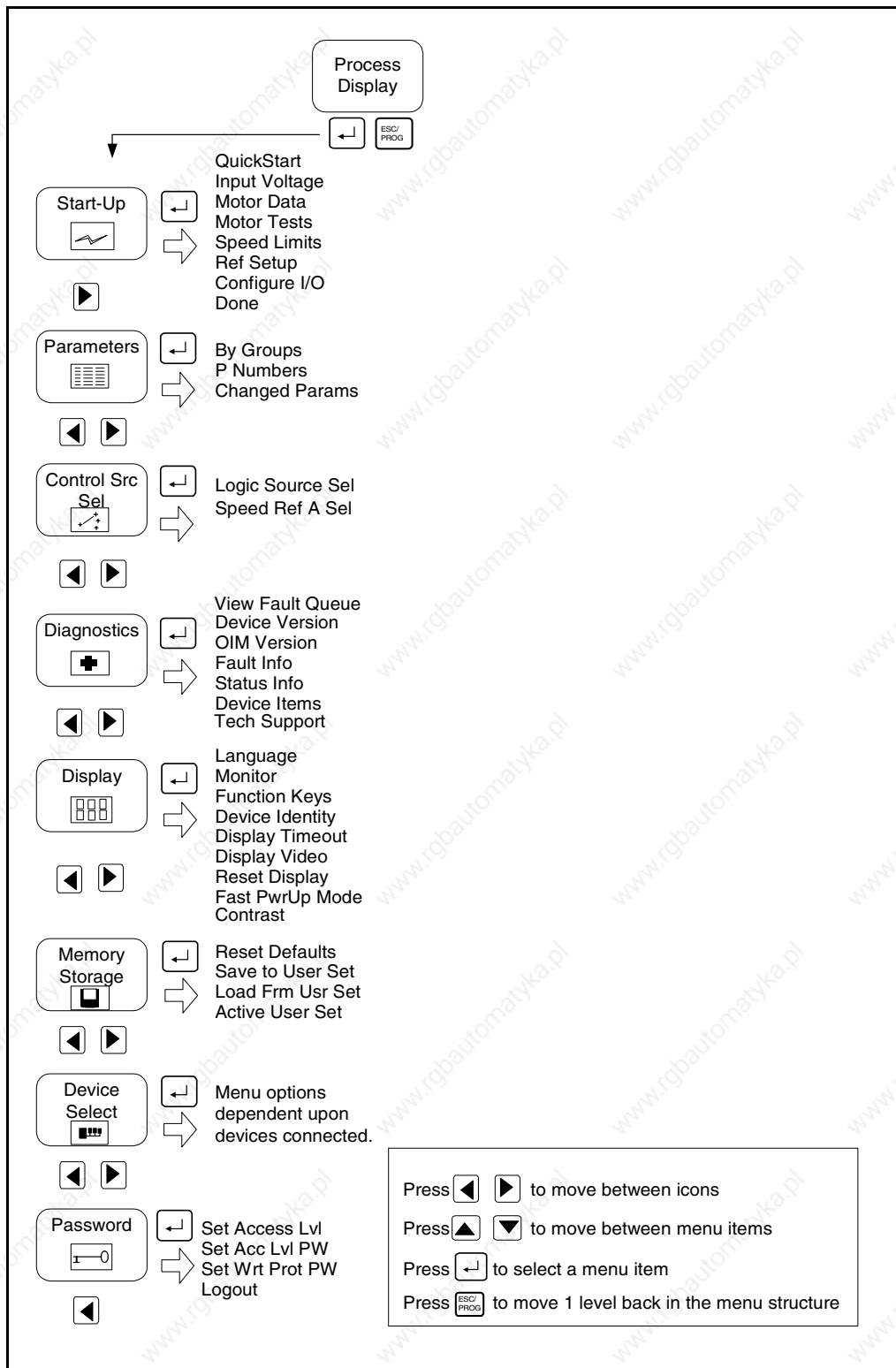

Figure B.5 – LCD OIM Menu Structure

B.4 Powering Up and Adjusting the LCD OIM

The first time the LCD OIM is powered up, you will be prompted to select a language for the display text. If the Start-Up routine has not been completed, the Start-Up menu is displayed immediately following the language selection screen.

On subsequent power ups, if both of these requirements have been met, the Main Menu is displayed after the initialization screen.

B.4.1 Selecting the Fast Power Up Feature

The fast power up feature bypasses the initialization screen at power up, and the Main Menu is displayed immediately. To select this feature, select Fast PwrUp Mode from the Display menu.

B.4.2 Adjusting the Screen Contrast

To adjust the screen contrast, select Contrast from the Display menu.

B.4.3 Resetting the Display

To return all the options for the display to factory-default values, select Reset Display from the Display menu.

B.5 Selecting a Device in the System

The LCD OIM can access and display data from any active drive or peripheral device on the network. The drive (port 0) is the default device selected.

To select a device, select the Device Select icon from the Main Menu. The options listed depend on what is connected to the network.

The name and DPI port number of the device being accessed is shown on the OIM's display (see figure B.4).

B.6 Using the LCD OIM to Program the Drive

The LCD OIM enables you to view and adjust parameters in the drive or in peripheral devices connected to the drive. The parameters available for viewing or adjustment depend on the device selected. See section B.5 for information about selecting a device.

The method of viewing and adjusting parameters is the same regardless of the device selected.

B.6.1 Viewing and Adjusting Parameters

Refer to chapter 9 for information on how to access the parameters in the drive.

Each parameter screen contains the following information:

- Parameter number
- Parameter name
- Current parameter value and units
- Parameter range

- F1 key defined as a toggle to enable you to view the parameter's current value and the factory-default value

See figure B.6 and table B.2 for instructions on how to adjust the parameter values.

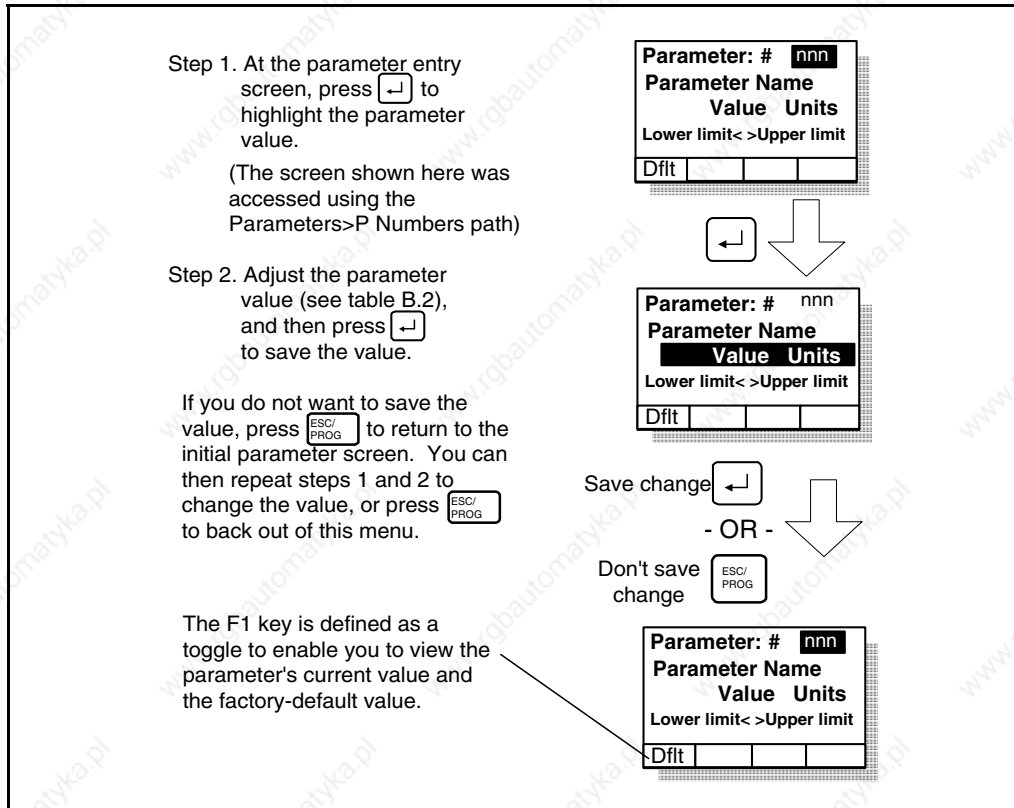

Figure B.6 – Adjusting Parameters

Table B.2 – How to Adjust Each Parameter Type

Parameter Type	How to Adjust
Numbered List	Use up/down arrow keys to advance through the list of options.
Bit	Use to move the cursor to the bit location you want to change. Use to change the value of the bit.
Numeric	Use to increase or decrease the value. - Or - Use to move the cursor from digit to digit, and use to increase or decrease the value of the digit.

To restore all parameters to their factory-default values, select Reset Defaults from the Memory Storage menu.

Note that the parameter values are retained through a line dip or power shutdown.

B.6.2 Loading and Saving User Sets

Drive configurations, called user sets, can be saved and recalled for use at any time. Up to three user sets can be saved in the LiquiFlo drive.

To **save** the current drive configuration, select Save to User Set from the Memory Storage menu.

To recall, or **load**, a user set, select Load Frm Usr Set from the Memory Storage menu.

To **identify** which user set is active, select Active User Set from the Memory Storage menu. The name of the last user set to be loaded into the drive will be displayed. "Active Set" means factory defaults have been restored. Assigning a Custom Name to a User Set

B.7 Monitoring the Drive Using the Process Display Screen on the LCD OIM

The process display screen enables you to monitor up to three process variables. You can select the display, parameter, scale, and text for each process variable being displayed.

The  key toggles between the programming screen and the process display screen. From the Main Menu screen, press F1 or F2 to select the process display screen. In addition, the process display screen becomes active if no keys have been pressed before the display timeout period expires. See section B.8.2 for information about setting the display timeout period.

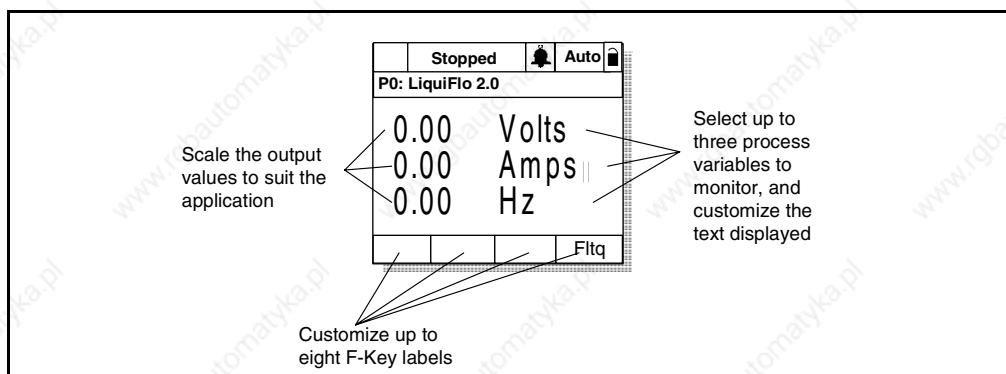

Figure B.7 – Process (User) Display Screen

B.8 Displaying and Changing the OIM Reference

You can display the reference value that the OIM is sending to the drive by pressing the up or down arrow key once when the process display screen is active. See figure B.8. The OIM reference can be used for the speed reference, PI reference, or trim reference.

To change the displayed reference, press and hold down either the up or down arrow key until the desired value is displayed. Release the key to return to the process display screen.

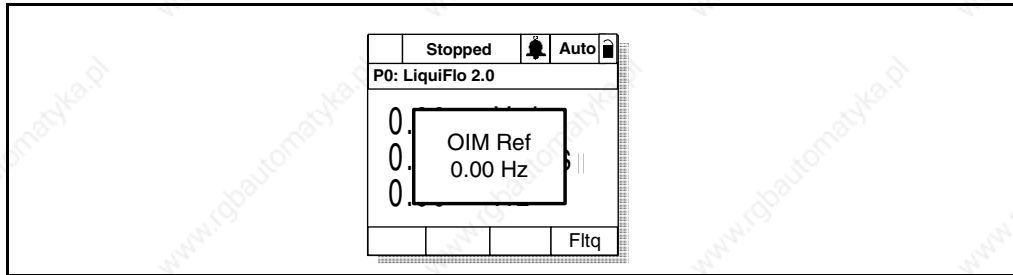

Figure B.8 – OIM Reference Displayed

Note that changing the value of the OIM reference does not affect the value of any other port reference.

The value of the OIM reference is saved through a power cycle if parameter 192 (Save OIM Ref) is set to save at power down.

B.8.1 Customizing the Process Display Screen

To customize the process display screen, select Monitor from the Display menu. See figure B.9.

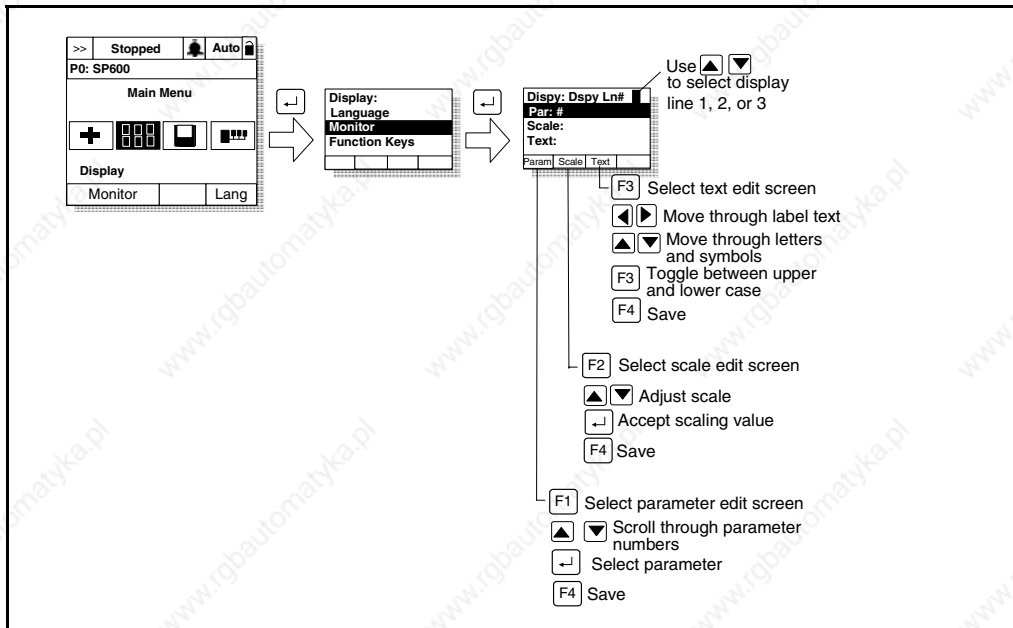

Figure B.9 – Customizing the Process Display Screen

B.8.2 Customizing the Function Keys

The function keys (F1, F2, F3, and F4, also called F-Keys) on the OIM can be customized to perform several pre-configured functions when the process display screen is active.

Up to eight function keys can be configured. Pressing while the display screen is active toggles between each set of four functions

As shipped from the factory, the F4 key is configured for the Clear Fault Queue function.

To assign a function to an F-Key, select the Display icon from the Main Menu as shown in figures B.10 and B.11.

The F-Key definitions are the same for all OIMs connected to the drive, regardless of the port used.

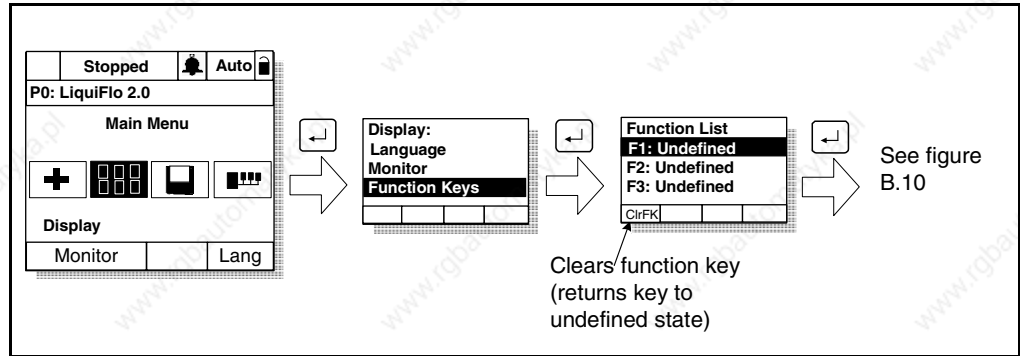

Figure B.10 – Accessing the Function Key Configuration Screens

Select from the list of preconfigured functions:

Undefined (default)

Load User Set 1-3: Loads the specified user set into active drive memory. The drive responds as if a value had been entered in Load Frm User Set (198), or Load Frm User Set was selected from the OIM's Memory Storage menu.



ATTENTION: Loading a user set with LevelSense Start (168) set to Enable can result in the drive starting immediately when all start conditions are met.

When this function is enabled, the user must ensure that automatic start up of the driven equipment will not cause injury to operating personnel or damage to the driven equipment. In addition, the user is responsible for providing suitable audible or visual alarms or other devices to indicate that this function is enabled and the drive may start at any moment. Failure to observe this precaution could result in severe bodily injury or loss of life.

Save User Set 1-3: Saves the active configuration to drive memory. The drive responds as if a value had been entered in Save to User Set (199) or Save to User Set was selected from the OIM's Memory Storage menu.

Acc/Dec Change: Toggles between the display of Acc/Dec rate 1 and Acc/Dec rate 2 (The value the drive is configured to go to, not the current value being used by the drive). This selection is based on the active value of the rate parameters (140-143). Therefore, when any of these parameters change, the actual acc/dec rates will dynamically change.

Preset Speed 1-6: Toggles the selected preset speed on and off and grants Hand (manual) reference control. Returns to Auto reference when the function is toggled.

View Fault Queue: Displays the Fault Queue screen (see chapter 12). Press  to return to the process display screen.

Next: (Reserved for future use.)

B.8.2.1 Customizing the Function Key Label Text

You can customize the text for each function key label (up to five characters). See figure B.11.

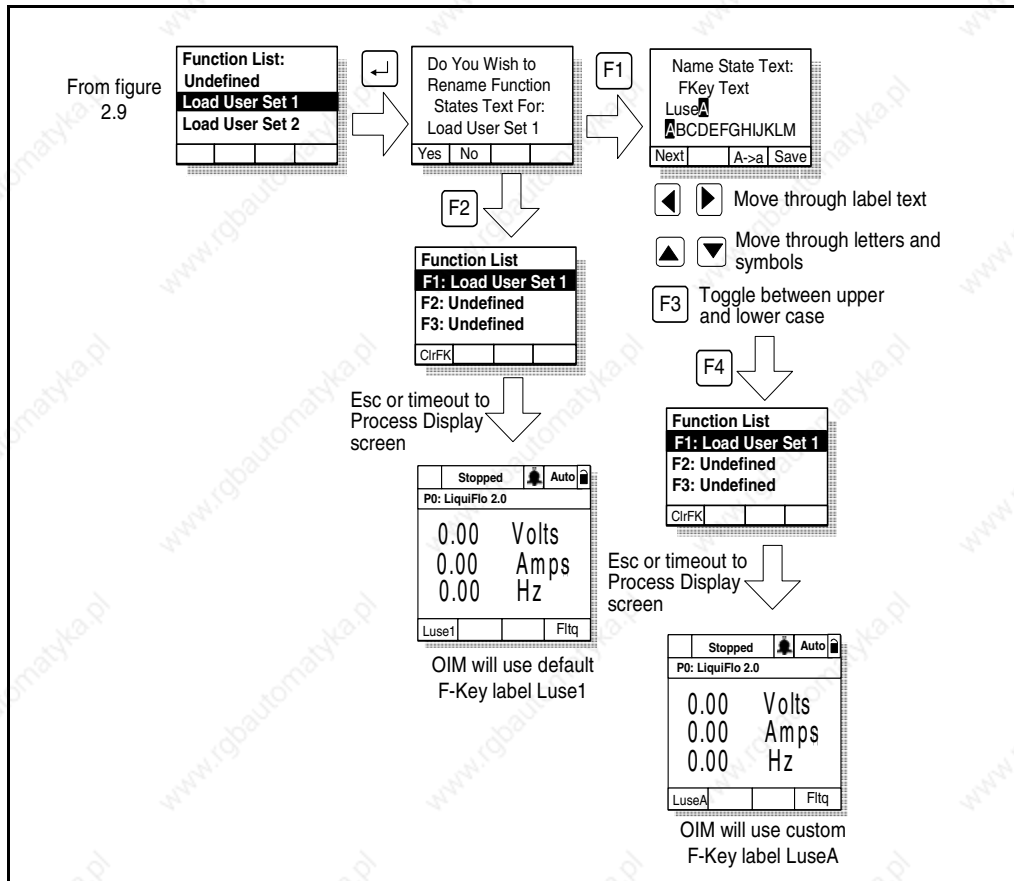



Figure B.11 – Customizing the Function Key Label Text

B.8.3 Setting the Display Timeout Period

When the OIM is inactive (that is, no keys have been pressed) for a user-specified period of time, the process display screen becomes active. To return to the previously active screen, press any key. To return to the Main Menu, press .

To set the display timeout period, select Display Timeout from the Display menu. The timeout period can range from 10 to 1200 seconds (20 minutes).

This feature can also be disabled by pressing the F1 key while in the display time screen.

Note that each OIM connected to the drive can have a different timeout period.

B.8.4 Using Reverse Video for the Process Display Screen

To select normal or reverse video for the process display screen, select Display Video from the Display menu. See figure B.12 for sample screens.

Note that each OIM connected to the drive can have a different display mode.

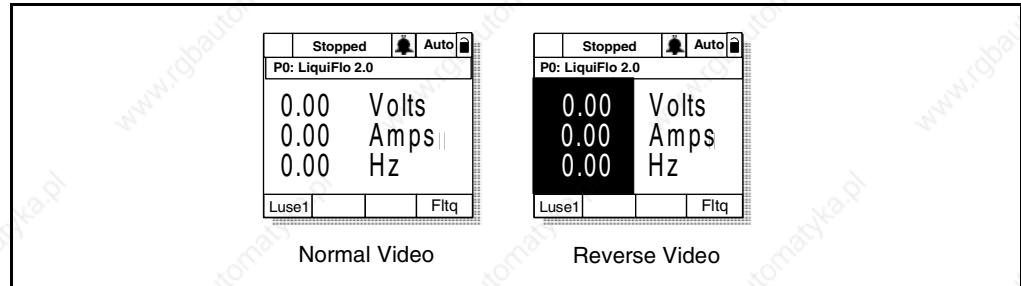

Figure B.12 – Selecting Reverse Video for the Process Display Screen

B.9 Controlling the Drive From the LCD OIM

When the OIM is the selected control source (set parameters 276-277 to Correct Port and 361-366 to 0), it can be used to control the drive:

- Start (Run)
- Stop
- Clear Faults

B.9.1 Starting the Drive

When the OIM is the selected control source, pressing issues a start command to the drive.

B.9.2 Stopping the Drive

Pressing will issue a stop command to the drive.

Important: Stop commands from any attached OIM will always be enabled.

www.rgbautomatyka.pl

LiquiFlo 2.0 Frame 3 Drive Wiring Diagrams

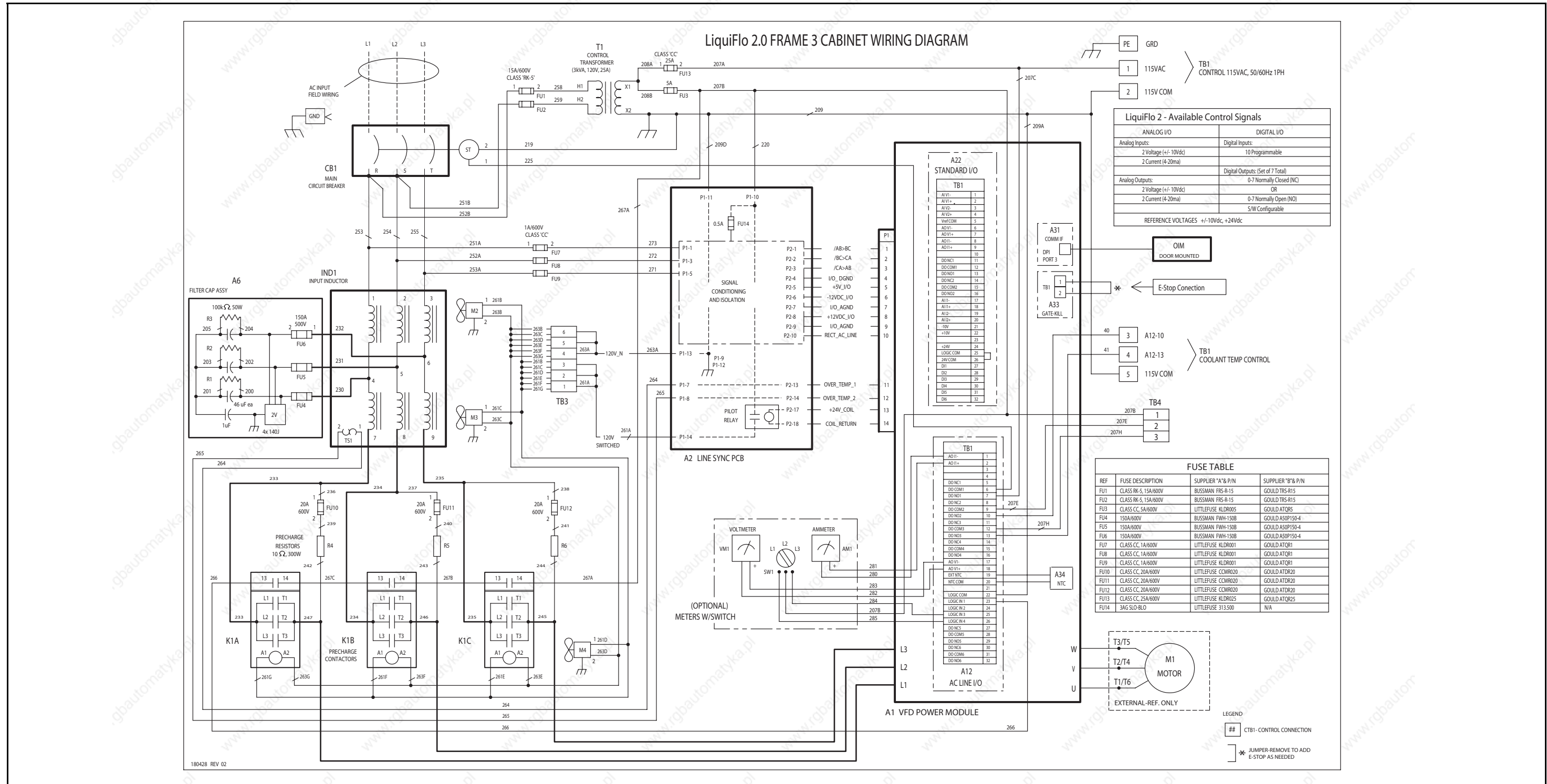

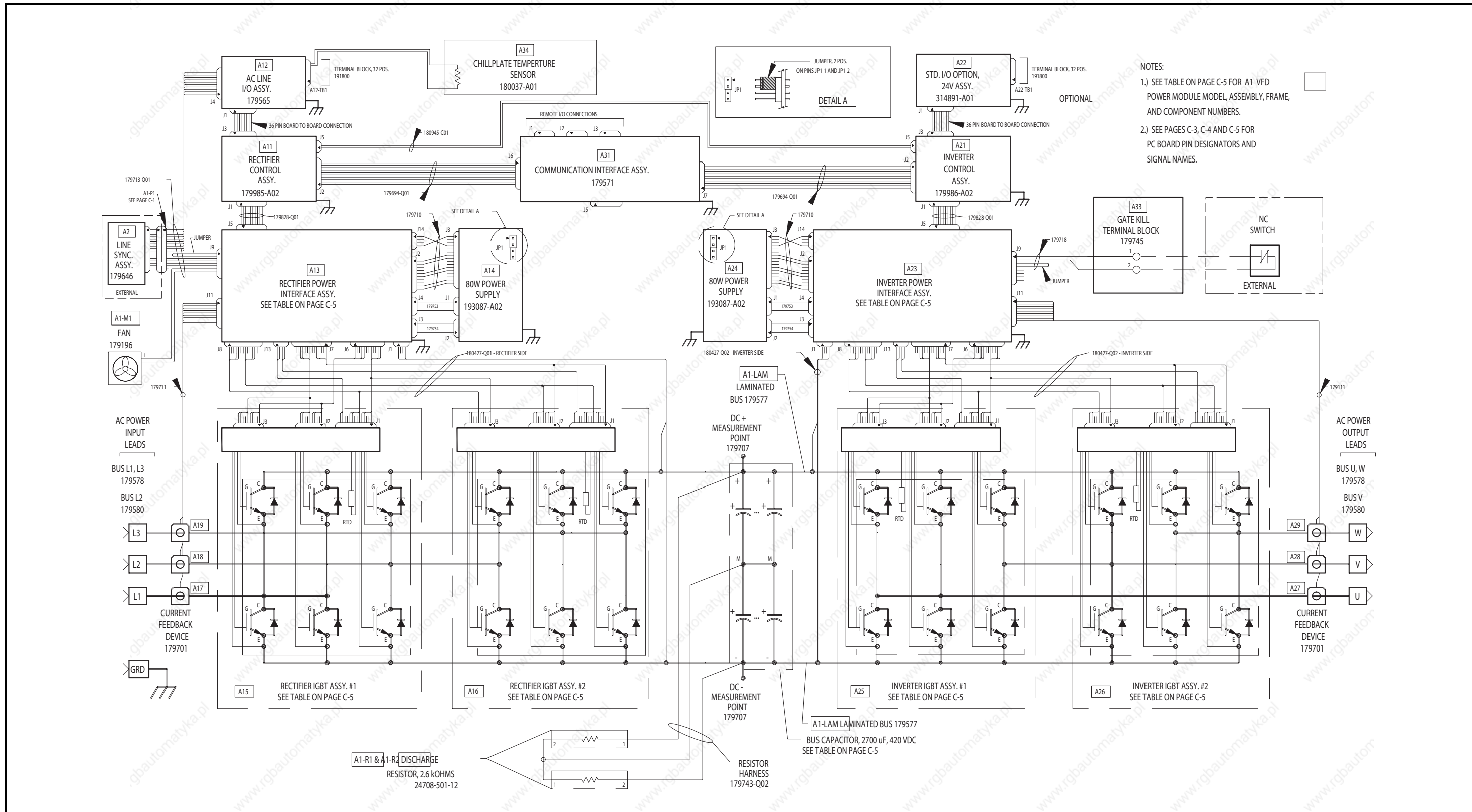

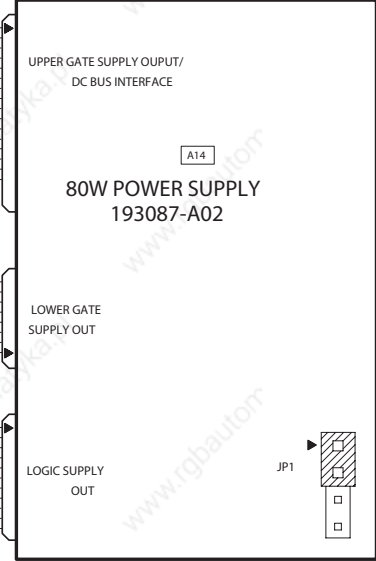
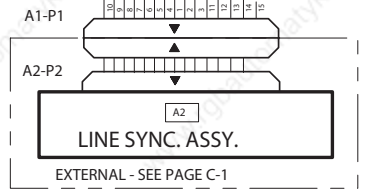
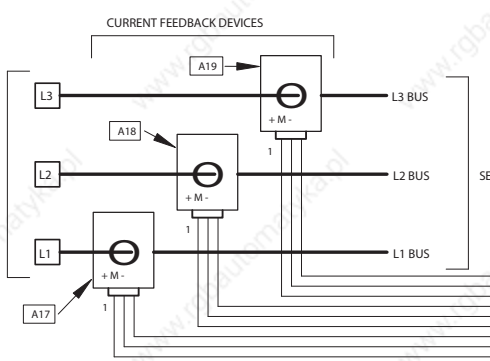
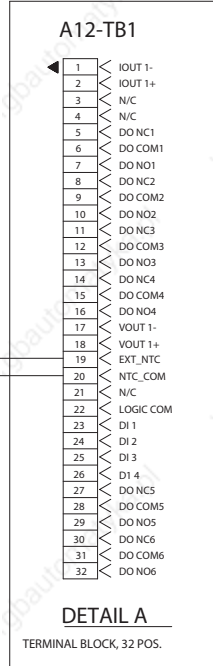
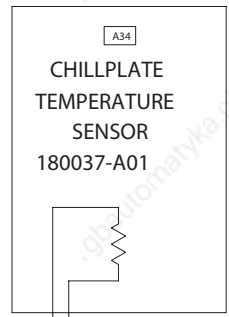
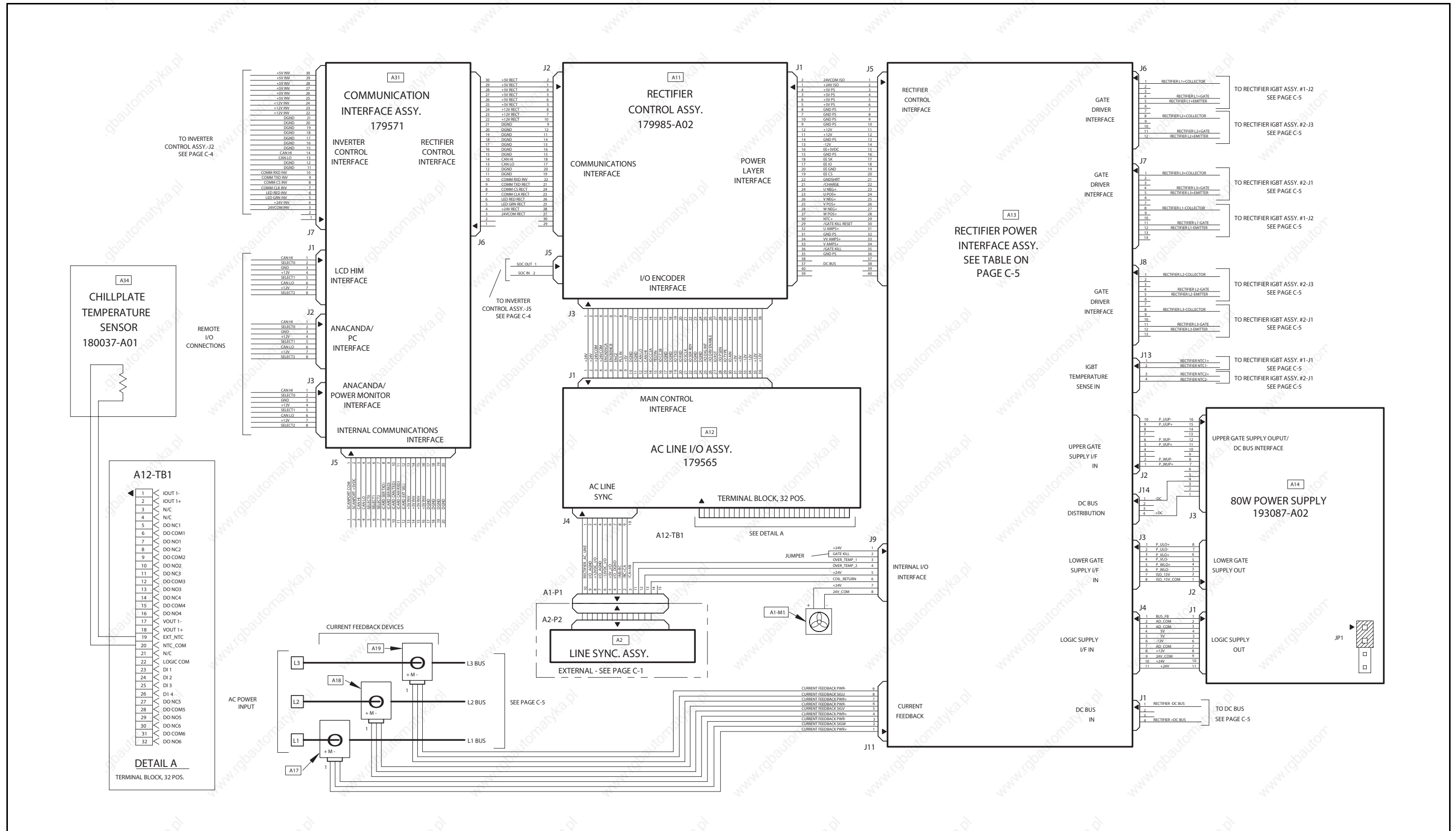

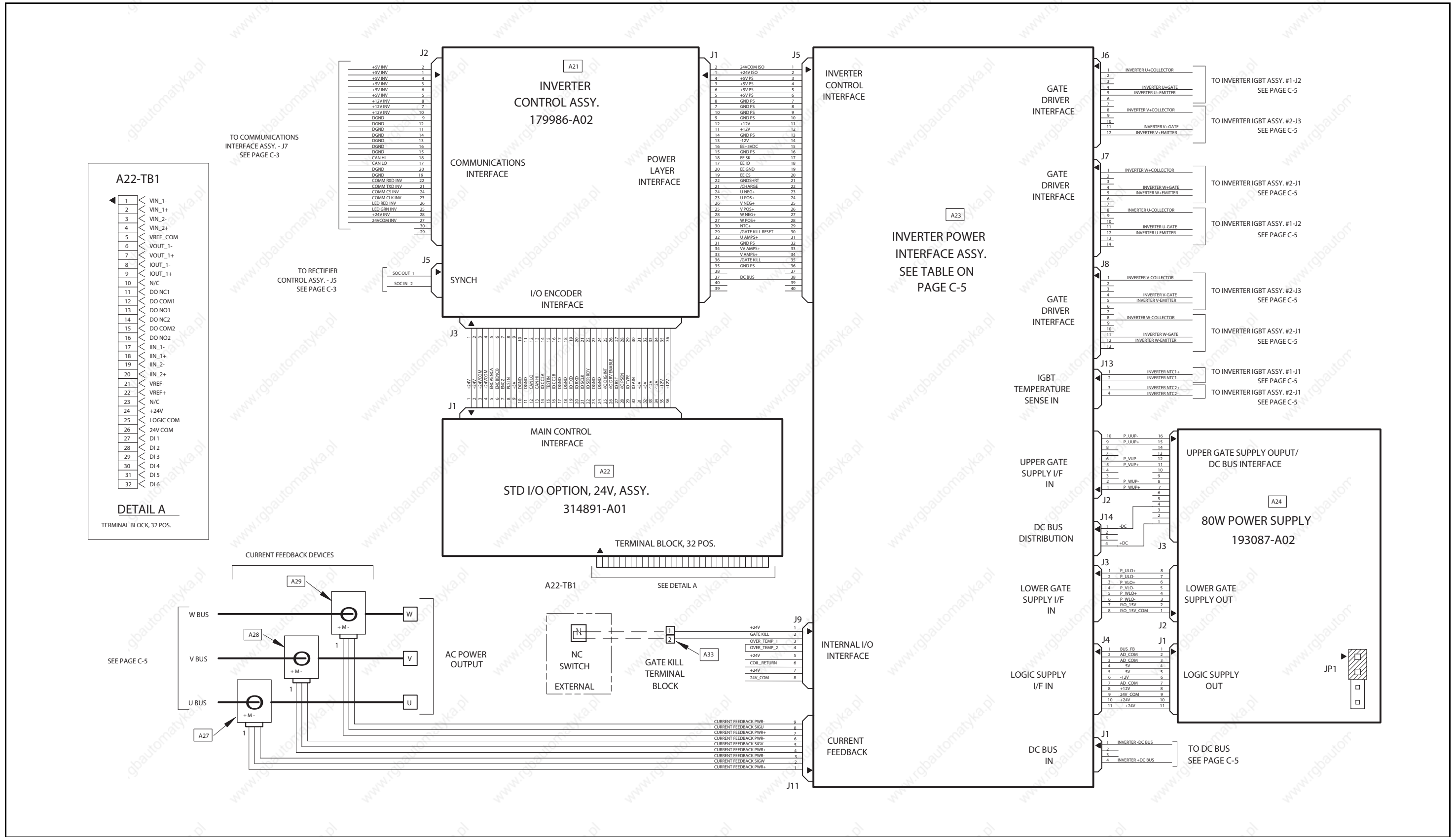

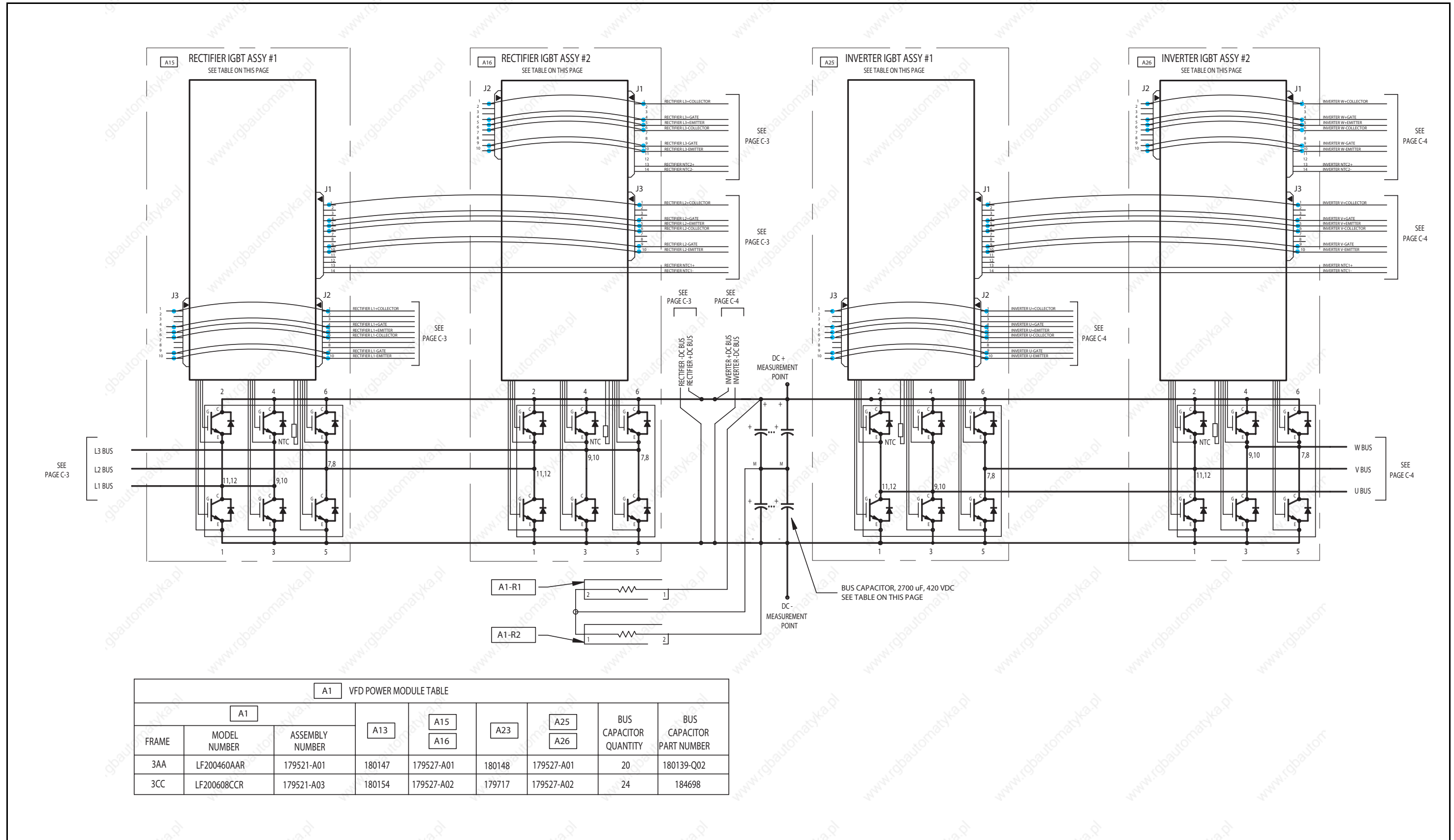

LiquiFlo 2.0 Frame 4 Drive Wiring Diagrams

LiquiFlo 2.0 FRAME 4 CABINET WIRING DIAGRAM

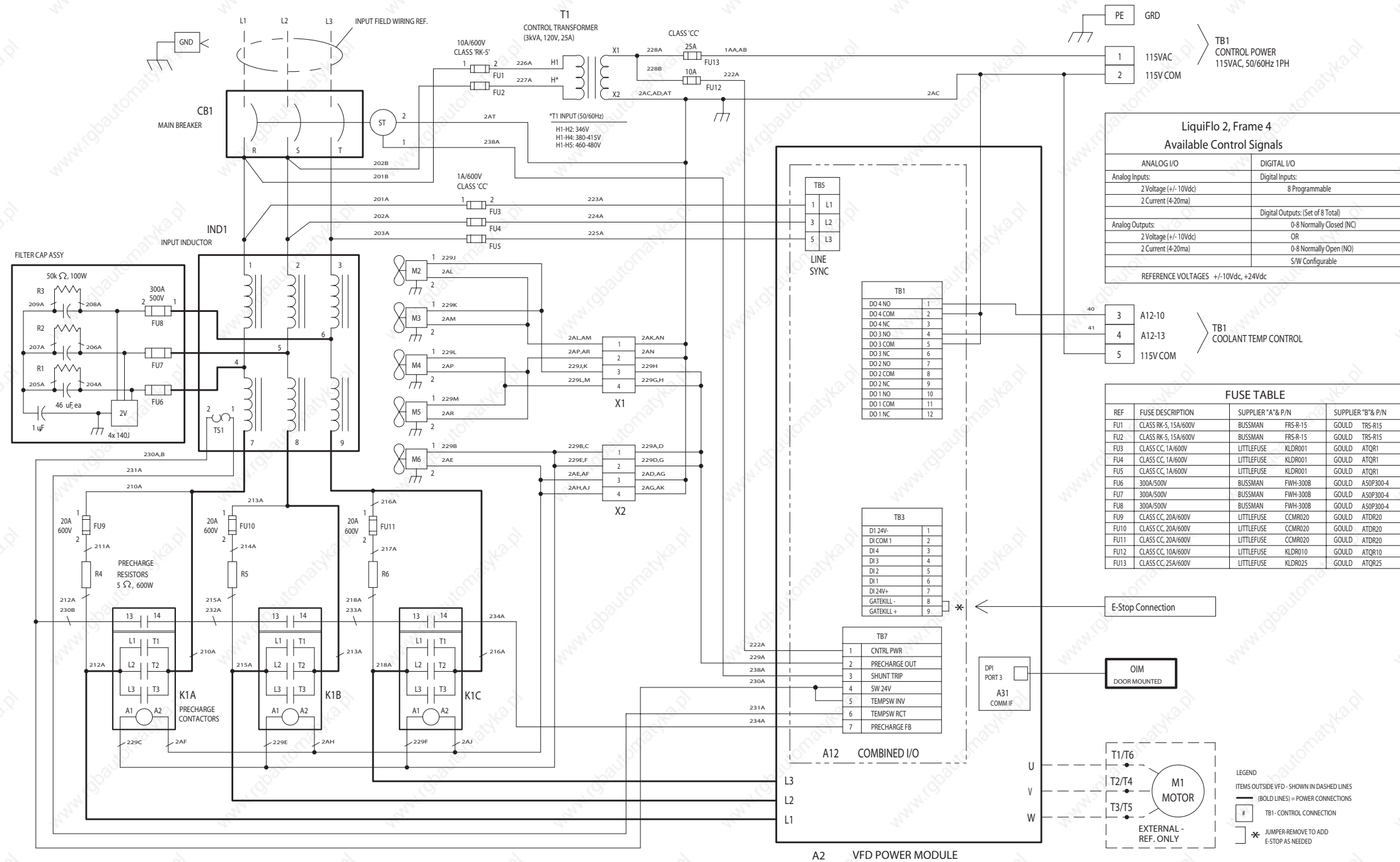

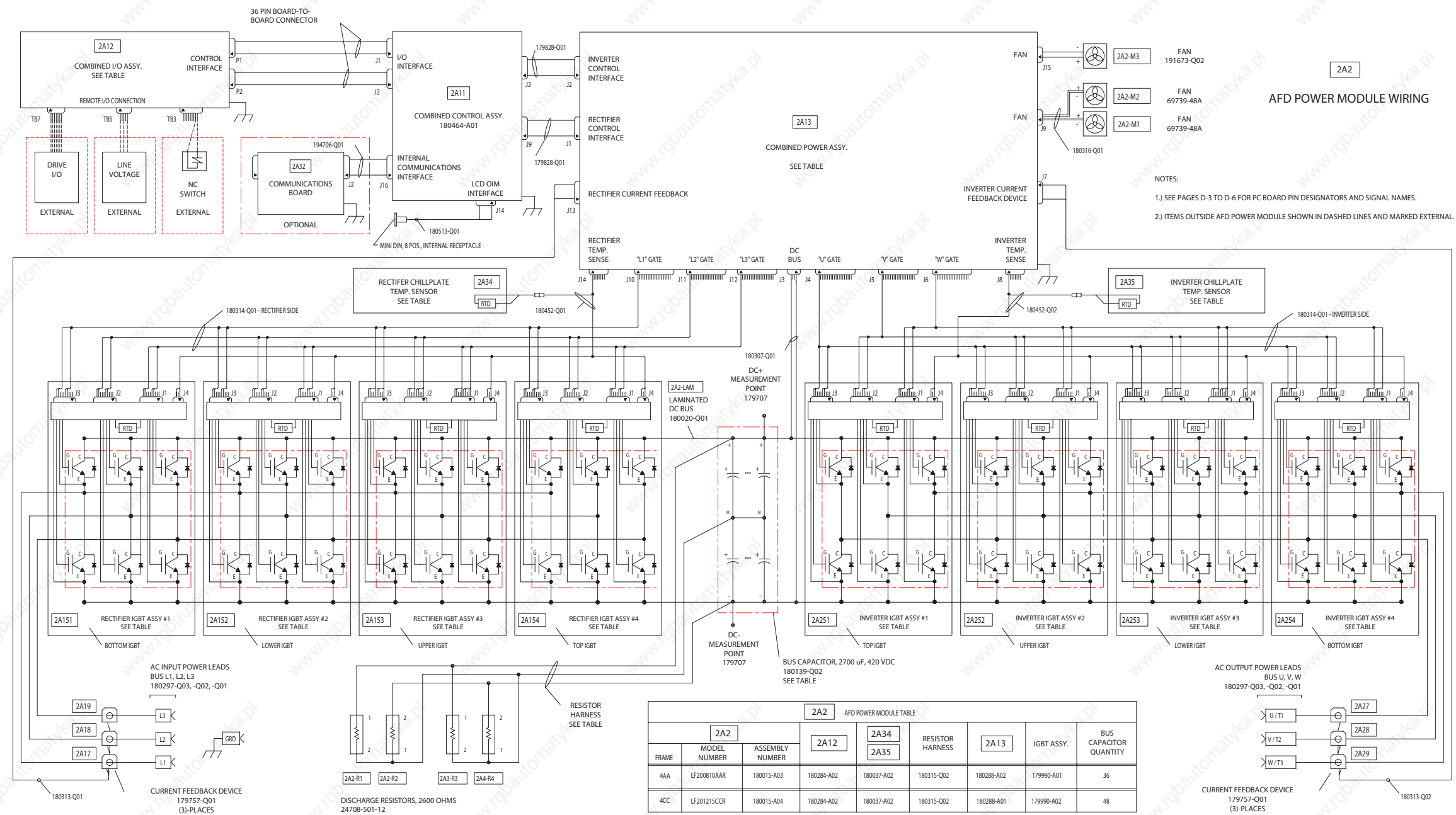

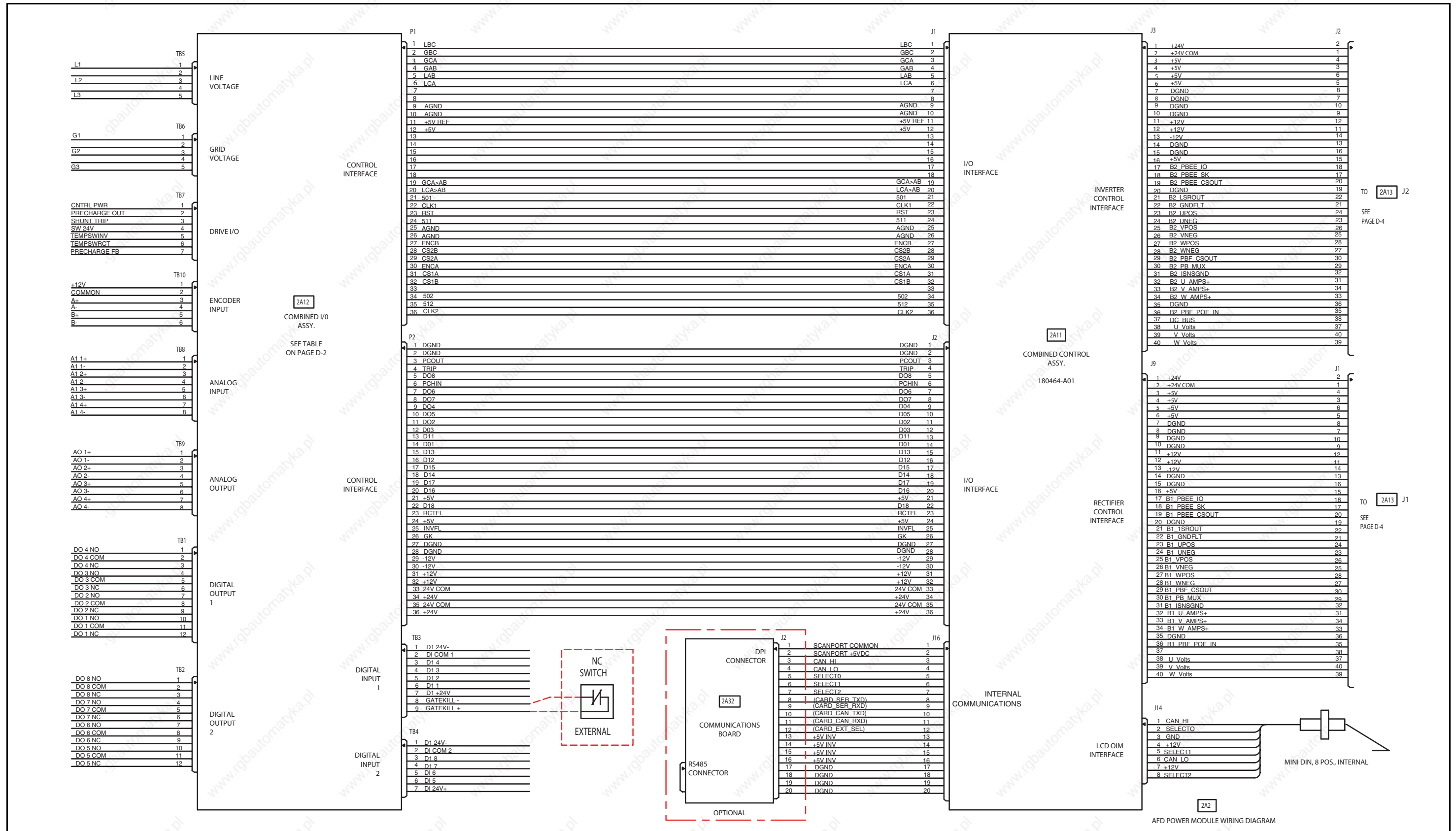

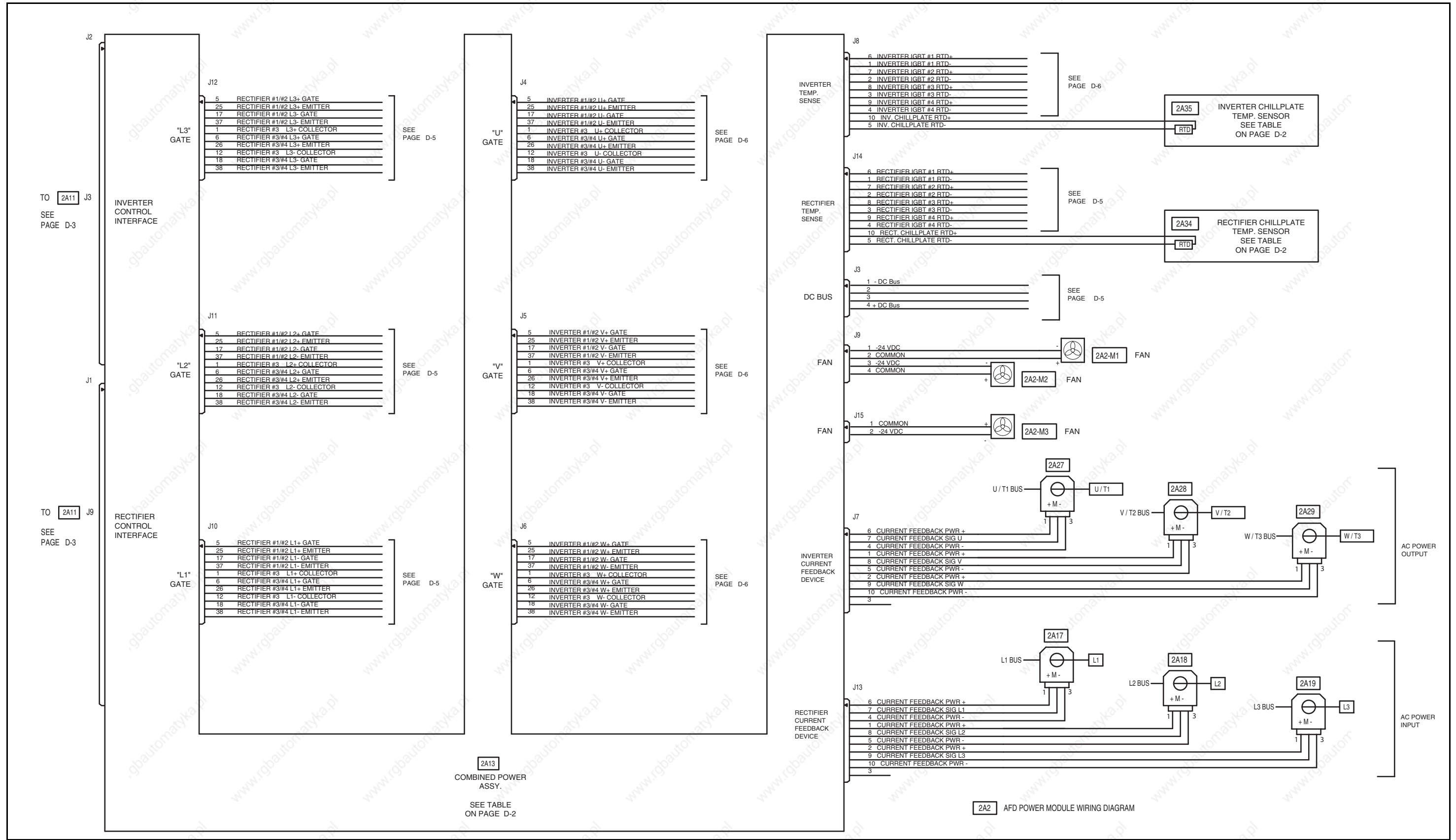

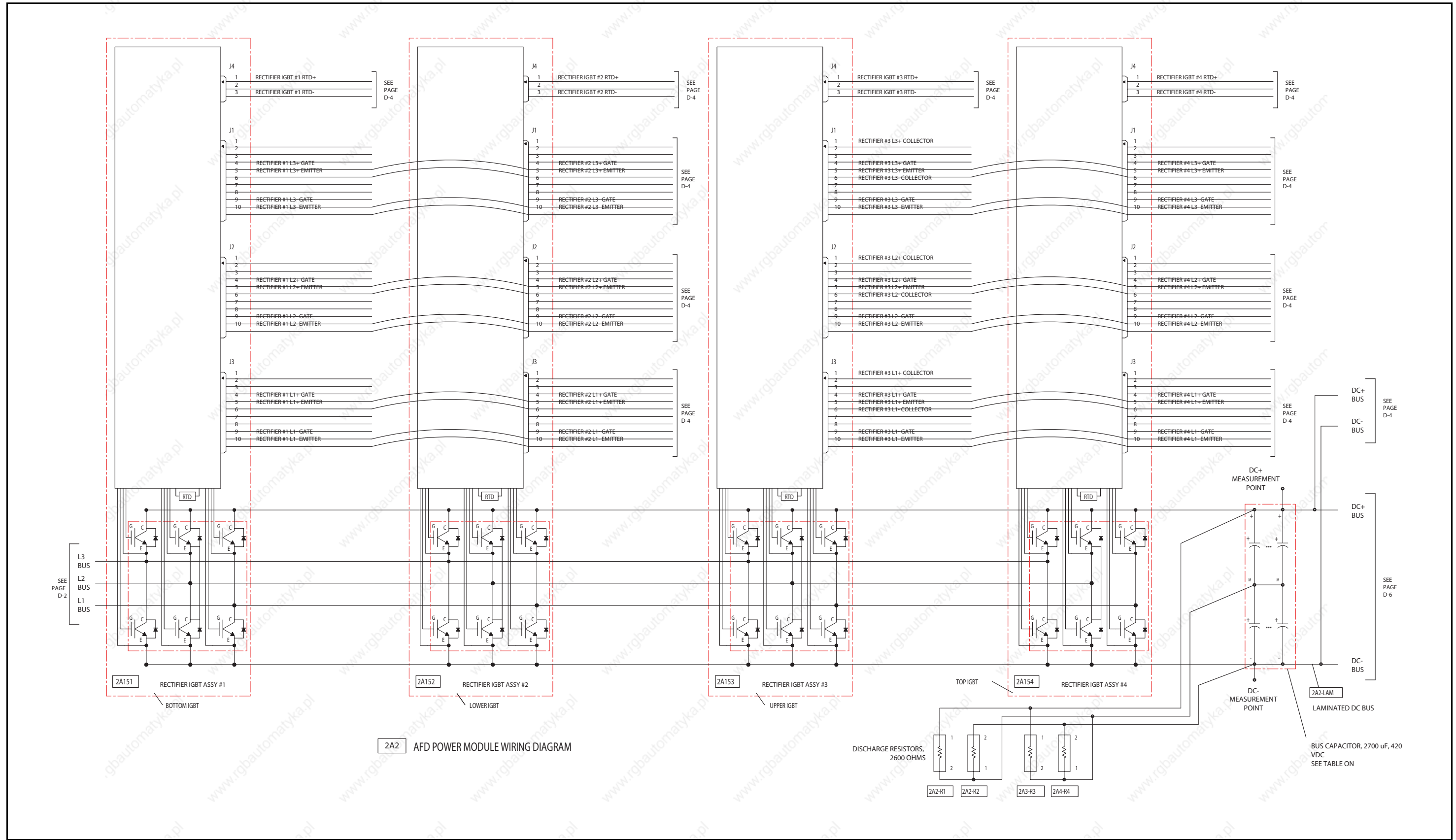

2A2 AFD POWER MODULE WIRING DIAGRAM

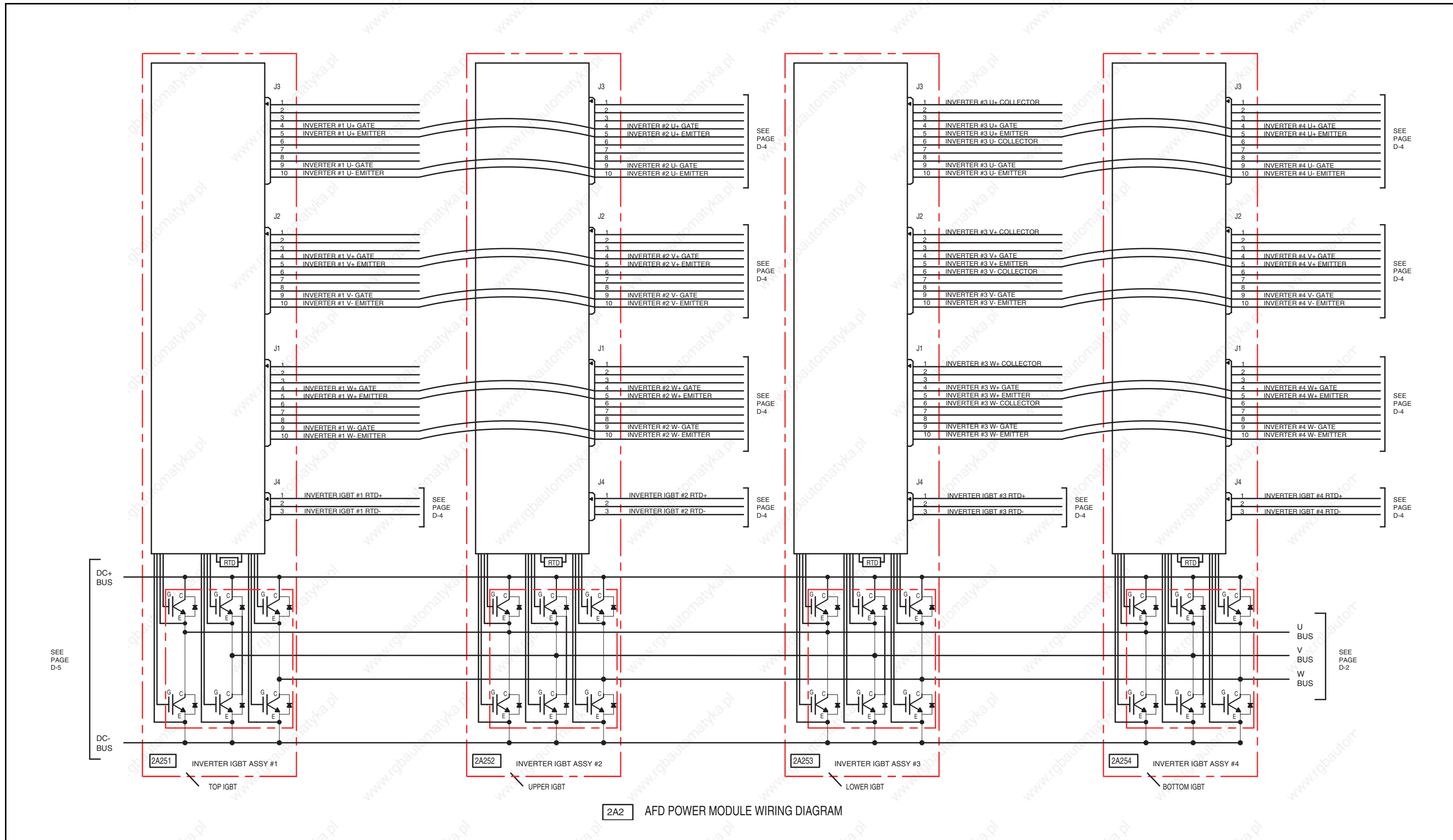

2A2 AFD POWER MODULE WIRING DIAGRAM

A

AC line distribution system capacity, A-1
AC Line I/O board
 description, 2-13
Accel Mask (281), 9-63
Accel Time 1 (140), 9-34
Accel Time 2 (141), 9-34
Active Current (Rectifier 5), 9-91
Active Voltage (Rectifier 11), 9-92
Alarm 1 @ Fault (229), 9-56
Alarm 1 Code (262), 9-60
Alarm 2 @ Fault (230), 9-56
Alarm 2 Code (263), 9-60
Alarm 3 Code (264), 9-60
Alarm 4 Code (265), 9-60
Alarm 5 Code (266), 9-60
Alarm 6 Code (267), 9-60
Alarm 7 Code (268), 9-60
Alarm 8 Code (269), 9-60
Alarm Clear (261), 9-60
Alarm Config 1 (259), 9-60
Alarms
 names cross-referenced to numbers, 10-7
Ambient Temp (Rectifier 129), 9-102
Analog In 1 Hi (322), 9-71
Analog In 1 Lo (323), 9-71
Analog In 1 Loss (324), 9-72
Analog In 2 Hi (325), 9-72
Analog In 2 Lo (326), 9-72
Analog In 2 Loss (327), 9-73
Analog In1 Value (16), 9-4
Analog In2 Value (17), 9-4
Analog In3 Value, 9-4
Analog In3 Value (18), 9-4
Analog Out Config (340), 9-73
Analog Out Scale Lo (344), 9-76
Analog Out1 Hi (343), 9-75
Analog Out1 Lo (344), 9-76
Analog Out1 Sel (342), 9-74
analog output, 2-14, 2-16
Anlg In Config (320), 9-70
Anlg In Sqr Root (321), 9-70
Anlg Out Absolut (341), 9-74
Appl Analog Output (31), 9-8
Appl Digital Output (30), 9-6
assembly number, drive, 2-1

Auto Rstrt Delay (175), 9-41
Auto Rstrt Tries (174), 9-40
Autotune (61), 9-16
avoidance frequency, *see* Skip Frequency

B

Base Motor Freq (Rectifier 109), 9-100
Break Frequency (72), 9-18
Break Voltage (71), 9-18
Bus Reg Gain (160), 9-37
Bus Reg Kd (165), 9-39
Bus Reg Kp (164), 9-39
Bus Reg Mode A (161), 9-38
Bus Reg Mode B (162), 9-38

C

CAN Bus Off Cut (Rectifier 164), 9-105
carrier frequency, A-1
checking the installation, 6-1
CML Ki (Rectifier 112), 9-101
CML Kp (Rectifier 113), 9-101
Cold Plate Temp (Rectifier 120), 9-101
Commanded Freq (2), 9-2
Compensation (56), 9-15
component locations, 2-2, 2-7, 2-8, 2-10, 2-11
conduit opening, required, 3-7
Control SW Ver (29), 9-6
Control SW Ver (Rectifier 29), 9-95
control wire sizes, 3-7
CS MSG Bad Cut (Rectifier 160), 9-104
CS Msg Rx Cnt (Rectifier 157), 9-104
CS Msg Tx Cnt (Rectifier 158), 9-104
CS Timeout Cut (Rectifier 159), 9-104
Current Limit (Rectifier 105), 9-99
Current Limit (Rectifier 151), 9-103
Current Lmt Gain (149), 9-36
Current Lmt Sel (147), 9-35
Current Lmt Val (148), 9-35

D

D/A Select (N) (Rectifier 171), 9-106
Data In A1 - Link A Word 1 (300), 9-67

Data In A2 - Link A Word 2 (301), 9-67
Data In B1 - Link B Word 1 (302), 9-67
Data In B2 - Link B Word 2 (303), 9-67
Data In C1 - Link C Word 1 (304), 9-68
Data In C2 - Link C Word 2 (305), 9-68
Data In D1 - Link D Word 1 (306), 9-68
Data In D2 - Link D Word 2 (307), 9-68
Data Out A1- Link A Word 1 (310), 9-68
Data Out A2 - Link A Word 2 (311), 9-68
Data Out B1- Link B Word 1 (312), 9-69
Data Out B2 - Link B Word 2 (313), 9-69
Data Out C1- Link C Word 1 (314), 9-69
Data Out C2- Link C Word 2 (315), 9-69
Data Out D1- Link D Word 1 (316), 9-69
Data Out D2- Link D Word 2 (317), 9-69
DB Resistor Type (163), 9-39
DC Brake Level (158), 9-37
DC Brake Lvl Sel (157), 9-37
DC Brake Time (159), 9-37
DC Bus Memory (13), 9-4
DC Bus Voltage (12), 9-4
DC Bus Voltage (Rectifier 10), 9-92
DC bus voltage measuring points, 10-1
DC bus, verifying capacitor voltage, 10-1
Decel Mask (282), 9-64
Decel Time 1 (142), 9-35
Decel Time 2 (143), 9-35
Device items, how to select, 10-42
Device version, how to determine, 10-40
Dig In Status (216), 9-52
Dig In Status (Rectifier 216), 9-108
Dig Out Status (217), 9-53
Dig Out Status (Rectifier 217), 9-108
Dig Out1 Level (381), 9-87
Dig Out1 OffTime (383), 9-87
Dig Out1 OnTime (382), 9-87
Dig Out2 Level (385), 9-88
Dig Out2 OffTime (387), 9-89
Dig Out2 OnTime (386), 9-89
Digital In1 Sel (361), 9-80
Digital In2 Sel (362), 9-80
Digital In3 Sel (363), 9-80
Digital In4 Sel (364), 9-80
Digital In5 Sel (365), 9-80
Digital In6 Sel (366), 9-80
Digital Out1 Sel (380), 9-86
Digital Out2 Sel (384), 9-88
Direction Mask (279), 9-63
Direction Mode (190), 9-44
displacement power factor, A-1
display timeout period, setting, B-12
DPI Baud Rate (270), 9-61
DPI Error (Rectifier 156), 9-104

drive
 identifying by model number, 2-1, 2-12
 mounting, 4-1
Drive Alarm (Rectifier 211), 9-107
Drive Alarm 1 (211), 9-50
Drive Alarm 2 (212), 9-50
Drive Checksum (203), 9-47
Drive Checksum (Rectifier 203), 9-107
Drive Logic Rslt (271), 9-61
Drive OL Count (219), 9-53
Drive OL Mode (150), 9-36
Drive Ramp Rslt (273), 9-62
Drive Ref Rslt (272), 9-62
Drive Status 1 (209), 9-48
Drive Status 2 (210), 9-49
Drive status parameters, accessing using LCD
 OIM, 10-39

E

Elapsed MWh (9), 9-3
Elapsed Run Time (10), 9-3
Elapsed Run Time (Rectifier 17), 9-93
environmental conditions, 3-1
Est Input Power (25), 9-5

F

Fault 1 Code (243), 9-59
Fault 1 Code (Rectifier 243), 9-112
Fault 1 Time (244), 9-59
Fault 1 Time (Rectifier 244), 9-112
Fault 2 Code (245), 9-59
Fault 2 Time (246), 9-59
Fault 3 Code (247), 9-59
Fault 3 Time (248), 9-59
Fault 4 Code (249), 9-59
Fault 4 Time (250), 9-59
Fault 5 Code (251), 9-59
Fault 5 Time (252), 9-59
Fault 6 Code (253), 9-59
Fault 6 Time (254), 9-59
Fault 7 Code (255), 9-59
Fault 7 Time (256), 9-59
Fault 8 Code (257), 9-59
Fault 8 Time (258), 9-59
Fault Amps (225), 9-54
Fault Amps D (Rectifier 225), 9-109
Fault Amps Q (Rectifier 224), 9-109
Fault Amps R (Rectifier 221), 9-108
Fault Amps S (Rectifier 222), 9-108
Fault Amps T (Rectifier 223), 9-109

Fault Bus Volts (226), 9-54
 Fault Clear (240), 9-58
 Fault Clear (Rectifier 240), 9-111
 Fault Clear Mode (241), 9-58
 Fault Clr Mask (283), 9-64
 Fault Config (Rectifier 238), 9-111
 Fault Config 1 (238), 9-58
 Fault Frequency (224), 9-54
 Fault Frequency (Rectifier 220), 9-108
 Fault queue
 accessing using LCD OIM, 10-38
 time stamp, 10-9
 Fault To Inverter (Rectifier 241), 9-111
 Fault Volts D (Rectifier 228), 9-110
 Fault Volts Q (Rectifier 227), 9-109
 Fault Volts Vdc (Rectifier 226), 9-109
 Faults
 about, 10-8
 clearing, 10-9
 fault parameters, accessing using LCD
 OIM, 10-39
 fault queue, 10-9
 names cross-referenced by numbers, 10-28
 types, 10-8
 F-Keys, customizing, B-10
 Flux Current (5), 9-2
 Flux Current Ref (63), 9-17
 Flux Up Mode (57), 9-15
 Flux Up Time (58), 9-16
 Flying Start En (169), 9-39
 Flying StartGain (170), 9-40
 function keys, *see* F-Keys

G

Ground Current (21), 9-5
 grounding, 4-2

I

I Imbalance Limit (Rectifier 62), 9-96
 I Imbalance Time (Rectifier 63), 9-96
 I/O terminal block, 2-14, 2-16
 Imbalance Count (221), 9-54
 Input Current R (Rectifier 2), 9-90
 input current rating, 2-12
 Input Current S (Rectifier 3), 9-90
 Input Current T (Rectifier 4), 9-90
 Input kW (Rectifier 13), 9-92
 Input Load Amps (Rectifier 106), 9-99
 Input Load Amps (Rectifier 150), 9-102
 input power, drive, 2-12

Input Pwr Factor (Rectifier 14), 9-92
 Input Voltage RS (Rectifier 7), 9-91
 Input Voltage ST (Rectifier 8), 9-91
 Input Voltage TR (Rectifier 9), 9-91
 installation
 site, requirements for, 3-1
 total area required, 3-2
 Inv Ambient Tmp (350), 9-78
 Inv Coldplt Tmp (349), 9-77
 Inv I/O ID V (354), 9-79
 Inv IGBT Tmp Bot (348), 9-77
 Inv IGBT Tmp Low (347), 9-77
 Inv IGBT Tmp Top (345), 9-76
 Inv IGBT Tmp Up (346), 9-77
 Inv PS +12 (352), 9-78
 Inv PS -12V (353), 9-78
 Inv PS Tmp (351), 9-78
 Invtr Base Temp (Rectifier 121), 9-101
 Invtr Base Temp (218), 9-53
 IR Voltage Drop (62), 9-17
 Ixo Voltage Drop (64), 9-17

J

Jog Mask (278), 9-63
 Jog Speed (100), 9-24

K

key descriptions, LCD OIM, B-5

L

Language (201), 9-47
 Language (Rectifier 201), 9-107
 Last Stop Source (215), 9-52
 LCD OIM, *see* OIM, LCD
 Life KWH (Rectifier 152), 9-103
 Life Power Cycles (Rectifier 155), 9-103
 Life Power Time (Rectifier 154), 9-103
 Life Run Time (Rectifier 153), 9-103
 line frequency, A-1
 Line Frequency (Rectifier1), 9-90
 Line I Imbalance (Rectifier 22), 9-94
 Line V Imbalance (Rectifier 23), 9-94
 line voltage variation, A-1
 Load Frm Usr Set (198), 9-46
 Load Frm Usr Set (Rectifier 198), 9-106
 Local Mask (285), 9-64
 logic inputs, 2-13, 2-15
 Logic Mask (276), 9-62

logic outputs, 2-13, 2-15

M

Man Ref Preload (193), 9-45
Max Motor Freq (Rectifier 108), 9-100
Max Motor Volts (Rectifier 107), 9-99
Maximum Freq (55), 9-14
Maximum Speed (82), 9-19
Maximum Voltage (54), 9-14
Minimum Speed (81), 9-19
model numbers, 2-1, 2-12
MOP Frequency (11), 9-4
MOP Mask (284), 9-64
MOP Rate (195), 9-45
motor lead lengths, 3-7, A-1
Motor NP FLA (42), 9-11
Motor NP Hertz (43), 9-12
Motor NP Power (45), 9-12
Motor NP RPM (44), 9-12
Motor NP Volts (41), 9-11
Motor OL Amps (48), 9-13
Motor OL Count (220), 9-53
Motor OL Hertz (47), 9-13
Motor Type (40), 9-10
Motoring kWh (Rectifier 15), 9-93
Mtr I Imbalance Limit (49), 9-13
Mtr I Imbalance Time (50), 9-13
Mtr NP Pwr Units (46), 9-12

O

OIM reference, displaying and changing, B-9

OIM, LCD

cables, B-1
display description, B-4
display timeout period, setting, B-12
drive status parameters, accessing, 10-39
fast power up, B-7
fault parameters, accessing, 10-39
fault queue, accessing, 10-38
F-Keys, customizing, B-10
installing and removing, B-1
key descriptions, B-5
loading and saving user sets, B-9
menu structure, B-6
monitoring the drive, B-9
parameters, accessing, 8-3
parameters, viewing and adjusting, B-7
process display screen, B-9
product version, determining, 10-40
program protection, selecting, 8-5
resetting the display, B-7
reverse video, selecting, B-13
screen contrast, adjusting, B-7
selecting a device, B-7
starting the drive, B-13
start-up routines on, 7-1
stopping the drive, B-13
viewing and adjusting parameters, B-7
Output Current (3), 9-2
output current rating, 2-12
Output Freq (1), 9-2
Output Power (7), 9-3
Output Powr Fctr (8), 9-3
Output Voltage (6), 9-3
output wiring, installing, 5-2
Overspeed Limit (83), 9-20

P

Param Access Lvl (196), 9-46
Param Access Lvl (Rectifier 196), 9-106
parameters
 accessing using LCD OIM, 8-3
 accessing using V*S Utilities, 8-3
 descriptions, 9-1 to 9-89
 organization, 8-2
 rectifier, ?? to 9-115
 types, 8-1
 viewing and adjusting using LCD OIM, B-7
password, write-protect, 8-5
PC MSG Rx Cut (Rectifier 161), 9-105
PC MSG Tx Cut (Rectifier 162), 9-105
PC Timeout Cut (Rectifier 163), 9-105

Phase U Amps (22), 9-5
 Phase V Amps (23), 9-5
 Phase W Amps (24), 9-5
 PI Configuration (124), 9-27
 PI Control (125), 9-28
 PI control, about, 9-28
 PI Error Meter (137), 9-34
 PI Fdbck Meter (136), 9-33
 PI Feedback Sel (128), 9-31
 PI Integral Time (129), 9-31
 PI Lower Limit (131), 9-32
 PI Output Meter (138), 9-34
 PI Preload (133), 9-32
 PI Prop Gain (130), 9-31
 PI Ref Meter (135), 9-33
 PI Reference Sel (126), 9-30
 PI Setpoint (127), 9-30
 PI Status (134), 9-33
 PI Upper Limit (132), 9-32
 power and enclosure ratings, 2-12
 Power Loss Level (186), 9-43
 Power Loss Mode (184), 9-43
 Power Loss Timer (185), 9-43
 Power Up Marker (242), 9-58
 Power Up Marker (Rectifier 242), 9-111
 power wiring, installing, 5-1
 Preset Speed 1 (101), 9-25
 Preset Speed 2 (102), 9-25
 Preset Speed 3 (103), 9-25
 Preset Speed 4 (104), 9-25
 Preset Speed 5 (105), 9-25
 Preset Speed 6 (106), 9-25
 Preset Speed 7 (107), 9-25
 process display screen, LCD OIM, B-9
 Product version, how to determine, 10-40
 program protection, 8-5
 programming basics, 8-1
 PWM Frequency (151), 9-36

R

Rated Amps (28), 9-6
 Rated Amps (Rectifier 28), 9-95
 Rated kW (26), 9-5
 Rated kW (Rectifier 26), 9-95
 Rated Volts (27), 9-6
 Rated Volts (Rectifier 27), 9-95
 Rct Ambient Tmp (350), 9-114
 Rct Coldplt Tmp (349), 9-114
 Rct I/O ID V (354), 9-115
 Rct IGBT Tmp Bot (348), 9-113
 Rct IGBT Tmp Low (347), 9-113

Rct IGBT Tmp Top (345), 9-112
 Rct IGBT Tmp Up (346), 9-113
 Rct PS +12V (352), 9-114
 Rct PS -12V (353), 9-115
 Rct PS Tmp (351), 9-114
 Rctfr Base Temp (Rectifier 122), 9-102
 Rctfr Base Temp (Rectifier 18), 9-93
 Rctfr I2T Overld (Rectifier 21), 9-94
 Rctfr IGBT Temp (Rectifier 19), 9-94
 Rctfr IT Overld (Rectifier 20), 9-94
 Reactive Current (Rectifier 6), 9-91
 Reactive Voltage (Rectifier 12), 9-92
 Rectifier Config (32), 9-8
 Rectifier Contrl (Rectifier 100), 9-97
 Rectifier Control (33), 9-9
 rectifier parameters, ?? to 9-115
 Rectifier Status (34), 9-10
 Rectifier Status (Rectifier 101), 9-98
 Reference Mask (280), 9-63
 Regen kWh (Rectifier 16), 9-93
 Replacement parts, 10-34
 Reset Meters (200), 9-47
 Reset Meters (Rectifier 200), 9-107
 Reset to Defaults (Rectifier 197), 9-106
 Restore Defaults (197), 9-46
 Ride Through Ena (Rectifier 64), 9-96
 Ride Through Sec (Rectifier 65), 9-96
 Run Boost (70), 9-18

S

S Curve % (146), 9-35
 Save MOP Ref (194), 9-45
 Save OIM Ref (192), 9-44
 Save To User Set (199), 9-46
 Save to User Set (Rectifier 199), 9-106
 signal wire sizes, 3-7
 site
 environmental conditions, 3-1
 requirements for, 3-1
 Skip Freq Band (87), 9-21
 Skip Frequency 1 (84), 9-20
 Skip Frequency 2 (85), 9-20
 Skip Frequency 3 (86), 9-20
 Sleep Level (182), 9-42
 Sleep Time (183), 9-42
 Sleep-Wake Mode (178), 9-41
 Sleep-Wake Ref (179), 9-41
 Slip Comp Gain (122), 9-27
 Slip RPM @ FLA (121), 9-27
 Slip RPM Meter (123), 9-27
 Speed Mode (80), 9-18

Speed Ref A Hi (91), 9-22
Speed Ref A Lo (92), 9-22
Speed Ref A Sel (90), 9-21
Speed Ref B Hi (94), 9-23
Speed Ref B Lo (95), 9-23
Speed Ref B Sel (93), 9-22
Speed Ref Source (213), 9-51
Start At PowerUp (168), 9-39
Start Inhibits (214), 9-51
Start Inhibits (Rectifier 214), 9-107
Start Mask (277), 9-63
Start/Acc Boost (69), 9-17
starting the drive using the LCD OIM, B-13
Start-Up menu, 7-2
Start-Up routines, 7-1
Status 1 @ Fault (227), 9-55
Status 2 @ Fault (228), 9-55
Status LEDs, 10-2
Stop Mode A (155), 9-36
Stop Mode B (156), 9-36
Stop Owner (288), 9-65
Stopping, 3-8
stopping the drive, 3-8
stopping the drive using the LCD OIM, B-13
SV Boost Filter (59), 9-16

T

TB Man Ref Hi (97), 9-24
TB Man Ref Lo (98), 9-24
TB Man Ref Sel (96), 9-23
Technical assistance, 1-2
temperature
 operating, A-1
 storage, A-1
terminal block, I/O, 2-14, 2-16
Testpoint 1 Data (235), 9-57
Testpoint 1 Data (Rectifier 235), 9-110
Testpoint 1 Sel (234), 9-57
Testpoint 1 Sel (Rectifier 234), 9-110

Testpoint 2 Data (237), 9-57
Testpoint 2 Data (Rectifier 237), 9-110
Testpoint 2 Sel (236), 9-57
Testpoint 2 Sel (Rectifier 236), 9-110
Time stamp, fault queue, 10-9
Torque Current (4), 9-2
Torque Perf Mode (53), 9-14
Trim Hi (119), 9-26
Trim In Select (117), 9-25
Trim Lo (120), 9-26
Trim Out Select (118), 9-26
Troubleshooting
 common symptoms and corrective
 actions, 10-29

U

user sets, loading and saving using LCD OIM, B-9

V

V Imbalance Lmt (Rectifier 60), 9-95
V Imbalance Time (Rectifier 61), 9-96
Vdc Command (Rectifier 104), 9-99
Vdc Optimize (Rectifier 102), 9-98
Vdc Reference (Rectifier 103), 9-98
VML Ki (Rectifier 110), 9-100
VML Kp (Rectifier 111), 9-100
VML Reset Level (Rectifier 114), 9-101
Voltage Class (202), 9-47

W

Wake Level (180), 9-42
Wake Time (181), 9-42
wire sizes
 control and signal, 3-7
wiring requirements, drive, 3-7

Documentation Improvement Form

Use this form to give us your comments concerning this publication or to report an error that you have found. For convenience, you may attach copies of the pages with your comments. After you have completed this form, please return it to:

Rockwell Automation / Reliance Electric Drives
Technical Documentation
6040 Ponders Court
Greenville, SC 29615

Fax: 864-284-5483

Publication Name:	
Publication Number: D2-3518-1	Publication Date: February 2005

Comments:

Your Name:	Date:
Company Name:	Phone: ()
Address:	

Thank you for your comments.

Technical Writing Internal Use	
Date:	DIF Number:
Follow-Up Action:	

**Rockwell
Automation**

Reach us now at www.rockwellautomation.com

Wherever you need us, Rockwell Automation brings together leading brands in industrial automation including Allen-Bradley controls, Reliance Electric power transmission products, Dodge mechanical power transmission components, and Rockwell Software. Rockwell Automation's unique, flexible approach to helping customers achieve a competitive advantage is supported by thousands of authorized partners, distributors and system integrators around the world.

Americas Headquarters, 1201 South Second Street, Milwaukee, WI 53204, USA, Tel: (1) 414 382 2000, Fax: (1) 414 382 4444
European Headquarters SA/NV, Boulevard du Souverain 36, 1170 Brussels, Belgium, Tel: (32) 2 663 06 00, Fax: (32) 2 663 06 40
Asia Pacific Headquarters, 27/F Citicorp Centre, 18 Whitfield Road, Causeway Bay, Hong Kong, Tel: (852) 2887 4788, Fax: (852) 2508 1846



**Rockwell
Automation**