

MiPC-50

Mini Workstation with
10.4" Flat-panel Display

Industrial PC Products

User's Manual

Copyright Notice

This document is copyrighted, January 1997, by Advantech Co., Ltd. All rights are reserved. Advantech Co., Ltd. reserves the right to make improvements to the products described in this manual at any time without notice.

No part of this manual may be reproduced, copied, translated or transmitted in any form or by any means without the prior written permission of Advantech Co., Ltd. Information provided in this manual is intended to be accurate and reliable. However, Advantech Co., Ltd. assumes no responsibility for its use, nor for any infringements of the rights of third parties which may result from its use.

Acknowledgments

MiPC-50CT, MiPC-50M, OPT112-50CT, OPT112-50M, and MiPC-50 series are trademarks of Advantech Co., Ltd. IBM and PC are trademarks of International Business Machines Corporation. MS-DOS is a trademark of Microsoft Corporation. All brand and product names mentioned herein are trademarks or registered trademarks of their respective holders.



三二〇 二〇. 97-415
Part No. 2002050000 1st Edition
Printed in Taiwan January 1997

Packing List

Before installing your MiPC-50, ensure that the following materials have been received:

- MiPC-50
- Utility Disks
- User's Manual
- Accessories for MiPC-50
 - HDD flat cable
 - Power Cord
 - Screw bag
 - Assembly mounting brackets

If any of these items are missing or damaged, contact your distributor or sales representative immediately.

Safety Instructions

1. Please read these safety instructions carefully.
2. Keep this User's Manual for later reference.
3. Disconnect this equipment from the AC outlet before cleaning. Don't use liquid or sprayed detergent for cleaning. Use a moist sheet or cloth for cleaning.
4. Use a power outlet which is near the equipment and easily accessible.
5. Protect this equipment from excessive humidity.
6. Lay this equipment on a reliable surface when in use. A drop or fall could cause damage to the equipment.
7. The openings on the enclosure are for air convection; to protect the equipment from overheating, **DO NOT COVER THE OPENINGS.**
8. Make sure the voltage of the power source is correct when connecting the equipment to the power outlet.
9. Place the power cord in such a way that people cannot step on it. Do not place anything over the power cord.
10. All cautions and warnings on the equipment should be noted and followed.
11. If the equipment is not used for a long time, disconnect the equipment from power sources to avoid damage from power surges.
12. Never pour any liquid into the openings. Doing so may cause fire or electrical shock.
13. Never open the equipment. For safety, the equipment should be opened only by qualified service personnel.
14. If one of the following situations arises, have the equipment checked by service personnel:
 - a. The power cord or plug is damaged.
 - b. Liquid has penetrated the equipment.
 - c. The equipment has been exposed to excessive moisture.
 - d. The equipment does not work well or according to the user's manual.
 - e. The equipment has been dropped and damaged.
 - f. The equipment has obvious signs of breakage.
15. **DO NOT LEAVE THIS EQUIPMENT IN AN UNCONDITIONED ENVIRONMENT, WITH STORAGE TEMPERATURES BELOW -20°C (-4°F) OR ABOVE 60°C (140°F), AS IT MAY DAMAGE THE EQUIPMENT.**

The sound pressure level at the operator's position according to IEC 704-1:1982 is equal to or less than 70dB(A).



Wichtige Sicherheitshinweise

1. Bitte lesen sie Sich diese Hinweise sorgfältig durch.
2. Heben Sie diese Anleitung für den späteren Gebrauch auf.
3. Vor jedem Reinigen ist das Gerät vom Stromnetz zu trennen. Verwenden Sie Keine Flüssig-oder Aerosolreiniger. Am besten dient ein angefeuchtetes Tuch zur Reinigung.
4. Die Netzanschlußsteckdose soll nahe dem Gerät angebracht und leicht zugänglich sein.
5. Das Gerät ist vor Feuchtigkeit zu schützen.
6. Bei der Aufstellung des Gerätes ist auf sicheren Stand zu achten. Ein Kippen oder Fallen könnte Verletzungen hervorrufen.
7. Die Belüftungsöffnungen dienen zur Luftzirkulation die das Gerät vor überhitzung schützt. Sorgen Sie dafür, daß diese Öffnungen nicht abgedeckt werden.
8. Beachten Sie beim Anschluß an das Stromnetz die Anschlußwerte.
9. Verlegen Sie die Netzanschlußleitung so, daß niemand darüber fallen kann. Es sollte auch nichts auf der Leitung abgestellt werden.
10. Alle Hinweise und Warnungen die sich am Geräten befinden sind zu beachten.
11. Wird das Gerät über einen längeren Zeitraum nicht benutzt, sollten Sie es vom Stromnetz trennen. Somit wird im Falle einer Überspannung eine Beschädigung vermieden.
12. Durch die Lüftungsöffnungen dürfen niemals Gegenstände oder Flüssigkeiten in das Gerät gelangen. Dies könnte einen Brand bzw. elektrischen Schlag auslösen.
13. Öffnen Sie niemals das Gerät. Das Gerät darf aus Gründen der elektrischen Sicherheit nur von autorisiertem Servicepersonal geöffnet werden.
14. Wenn folgende Situationen auftreten ist das Gerät vom Stromnetz zu trennen und von einer qualifizierten Servicestelle zu überprüfen:
 - a - Netzkabel oder Netzstecker sind beschädigt.
 - b - Flüssigkeit ist in das Gerät eingedrungen.
 - c - Das Gerät war Feuchtigkeit ausgesetzt.
 - d - Wenn das Gerät nicht der Bedienungsanleitung entsprechend funktioniert oder Sie mit Hilfe dieser Anleitung keine Verbesserung erzielen.
 - e - Das Gerät ist gefallen und/oder das Gehäuse ist beschädigt.
 - f - Wenn das Gerät deutliche Anzeichen eines Defektes aufweist.

Der arbeitsplatzbezogene Schalldruckpegel nach DIN 45 635 Teil 1000 beträgt 70dB(A) oder weiger.

Contents

Chapter 1 Introduction	1
Description	2
Specifications	4
LCD specifications	6
Dimensions	7
Panelmounting	8
Chapter 2 System Setup	9
General	10
Removing top cover and rear panel	11
Adding cards	12
Removing the protective cover	13
Installing optional drives	14
Chapter 3 Maintenance	15
The passive backplane	16
Power supply and cooling fan	17
The flat panel display	18
LCD backlight	19
Appendix A Touchscreen	21
General information	22
Specifications	22
Environmental specifications	23
Appendix B Power Supply Specifications	25
Specifications of model MRW170	26
Connector locations	26
Input characteristics	27
Output characteristics	28
General specifications	29
Input and output connectors	29
Output power rating	29
Dimensions	30

1.1 Description

The MiPC-50 Series mini workstations are compact units that meet all the requirements for an industrial man-machine interface. A heavy-duty steel chassis and a sealed aluminium alloy front panel meet the toughest industrial and environmental protection standards. MiPC-50 Series workstations include a 4-slot ISA-bus (PC/AT compatible) passive backplane, 65-watt power supply, a floppy disk drive and space for a hard disk drive.

You can choose the MiPC-50 with a 10.4" color TFT LCD (MiPC-50CT), B/W LCD (MiPC-50M) flat panel display. The MiPC-50 is compact, lightweight and easy to maintain.

Flexible, Expandable Industrial Workstations

PC based systems can monitor and sample the data of several traditional PLC controllers simultaneously. They are able to take full advantage of a wide range of available software programs, and upgrading can be quickly and easily achieved with the use of plug-in CPU cards.

The user interface of the MiPC-50 can be customized with additional components. Advantech is the leader in half-size technology. When we designed the MiPC-50 series we took advantages of the half-size form factor to give you the tightest package possible. Don't worry about finding hardware for your system. Unlike other workstation manufacturers, we produce everything you need, including a full line of half-size CPU cards and DA&C hardware. For users who require a more intuitive interface we supply touchscreens (See Appendix A for a detailed description). Workers can control a process by simply touching their fingers to the monitor. This option is especially useful for Windows-based operation.

Features

- Compact mini workstation / industrial man-machine interface
- 4-slot ISA bus (PC/AT compatible) passive backplane
- NEMA 4 (IP56)/NEMA 12 (IP52) front panel protection
- Two types of 10.4" Flat-panel displays, each with 640x480 resolution:
 - 10.4" color TFT LCD display (MiPC-50CT)
 - 10.4" B/W LCD display (MiPC-50M)
- Full-line of half-size plug-in cards available
- 65-watt power supply
- UL, CSA and TÜV standards
- Panel mount
- Open slot on the side for convenient drive cable connection
- Includes one 3½" FDD and reserves space for one 3½" HDD
- Optional touchscreen kit for more intuitive interface

Applications

- Display unit for PLCs
- Industrial controller
- Man-machine interface
- Panel mount station
- Process monitoring

1.2 Specifications

General

- **Construction:** Heavy-duty steel chassis, hardened aluminium alloy front panel
- **Disk drive housing:**
Accommodates one 3½" FDD and one 3½" HDD (HDD optional)
- **Cooling system:** Air convection
- **Dimensions:**
Width: 13.5" (344 mm)
Height: 10.2" (260 mm)
Depth: 6.0" (152.4 mm)
- **Weight:** 16.5 lbs (7.5kg)

Passive Backplane

- **Slots:** 4 half-size ISA-bus slots
- **PC board:**
4-layer PCB with ground and power planes for reduced noise and lower power supply impedance
- **Indicators:** LEDs for +5V, +12V and -12V, -5V

Power Supply

- **Maximum output power:** 65 watts
- **AC input voltage:** 85 to 132 V_{ac} or 180 to 264 V_{ac}, auto-ranging
- **Output voltage:** +5V@5A; +12V@1.7A, -5V@0.5A, -12V@1A
- **MTBF:** 50,000 hours
- **Safety standards:** UL/CSA/TÜV approved
- **EMI:** Meets FCC/VDE Class A

Environmental Specifications

- **Operating temperature:** 32 to 122°F (0 to 50°C)
- **Relative humidity:** 10% to 95% @40°C, non-condensing
- **Altitude:** 10,000 ft. (3000 meters)
- **Vibration (operating):**
5 to 17 Hz, 0.1" double-amplitude displacement
17 to 500 Hz, 1.5 G peak to peak
- **Shock (operating):** 10 G peak acceleration (11 msec. duration)
- **Safety:** Meets UL/CSA/TÜV
- **EMI:** Meets FCC/VDE Class A
- **CE compliant**

Touchscreen (optional)

- **Type:** Analog resistive
- **Resolution:** Continuous
- **Light transmission:** 75%
- **Controller:** RS-232 interface
- **Power consumption:** +5V @200mA
- **Software driver:** Supports both DOS and Windows

1.3 LCD specifications

Panel PCs	MIPC-50CT	MIPC-50M
Display type	TFT Color LCD	Mono LCD
Size(diagonal)	10.4"	10.4"
Max. resolution	640 x 480	640 x 480
Max. colors or gray scales	256K colors	64 grayscale levels
Dot size (mm x mm)	0.33 x 0.33	0.33 x 0.33
Luminance (cd/m ²)	160	70
Viewing angle	90°	50°
LCD model	Toshiba LTM10C042 or compatibles	Sharp LM64P89 or compatibles
Temperature	0~50°C	0~45°C
Video card	PCA-6653-50CT	PCA-6653-50M
Brightness adjustment	No	Yes
Contrast adjustment	No	Yes
VR controls	N/A	Contrast
Simultaneous mode	Yes	Yes
LCD MTBF	50,000 hours	50,000 hours
Backlight lifetime	10,000 hours	10,000 hours

Notice: A VGA card is included with an adapter for different types of LCD panels. Users who wish to change or modify the display must change the video card's jumper settings. See the video card manual for jumper setting information.

1.4 Dimensions

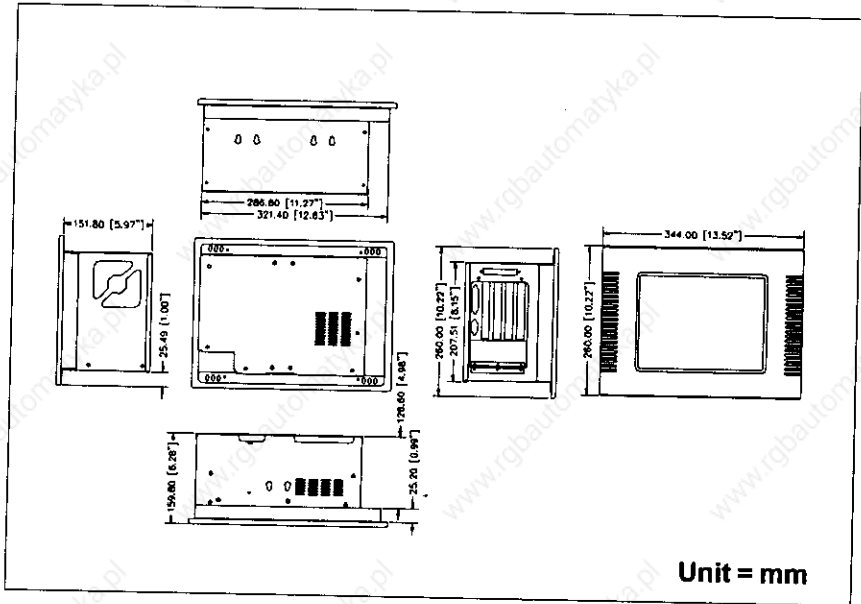

Figure 1-1: Dimensions

1.5 Panelmounting

The MiPC-50 will stand on a shelf or a table, or you can mount it in a panel. Included with your MiPC-50 you'll find three panel-mount brackets. The brackets have two screws that stick out and fit in the keyhole slots on the workstation chassis. The brackets also have a long bolt with spring which you tighten to secure the workstation against the back of the panel.

Slide the MiPC-50 backwards into the panel opening. Attach the three mounting brackets by sliding the two screw heads into the keyhole slots on the chassis cover. Fix the MiPC-50 tightly to the panel by screwing out the long bolts on the brackets.

Warning! *Before panelmounting, you should have added your cards, drives, and other equipment and switched the MiPC-50 on to confirm that it works properly.*

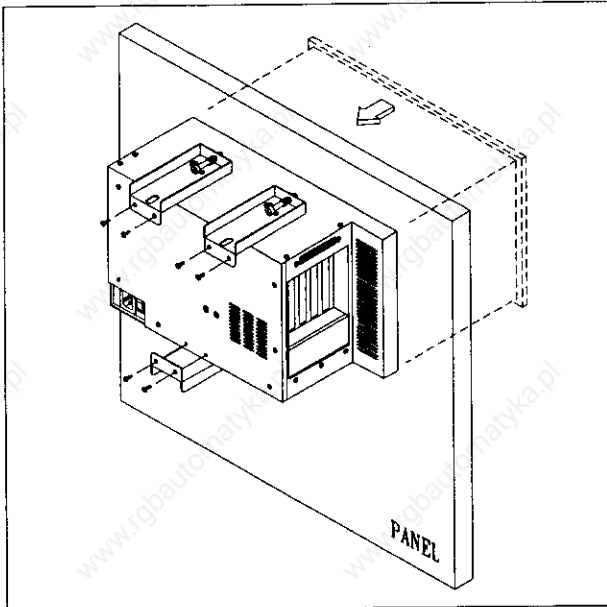

Figure 1-2: Panelmounting
Cutout dimension=325.4(W)x210.51(H)

CHAPTER
2

System Setup

- **General**
- **Removing top cover and rear panel**
- **Adding cards**
- **Removing the protective cover**
- **Installing optional drivers**

2.1 General

When you receive your mini-workstation, you should be able to plug-and-play since we have already installed and tested the workstation's components in the factory. However, if you need to customize the MiPC-50 yourself, you will see that it is a simple job.

The MiPC-50 basically consists of a main chassis that is fitted into a protective cover. Your MiPC-50's backplane is easily accessible by removing its top cover and rear panel. Removal of these panels provides you with all the space you need to insert or remove cards and connect or disconnect cables. Other components like the disk drive bay, power supply and display are 100% accessible after sliding the main chassis out of its protective case.

Before you begin, take the workstation out of its shipping container and check the contents against the packing list.

Warning!  Do not begin your installation until you have verified that no power is flowing within the MiPC-50. Power must be switched off and cables unplugged. Every time you service the MiPC-50, you should be aware of this.

2.2 Removing top cover and rear panel

To access the backplane, remove the top cover and rear panel.

First remove the five screws that secure the top cover, then remove the top cover (see Figure 2-1).

After you remove the top cover, unscrew the six screws on the rear panel and remove the rear panel.

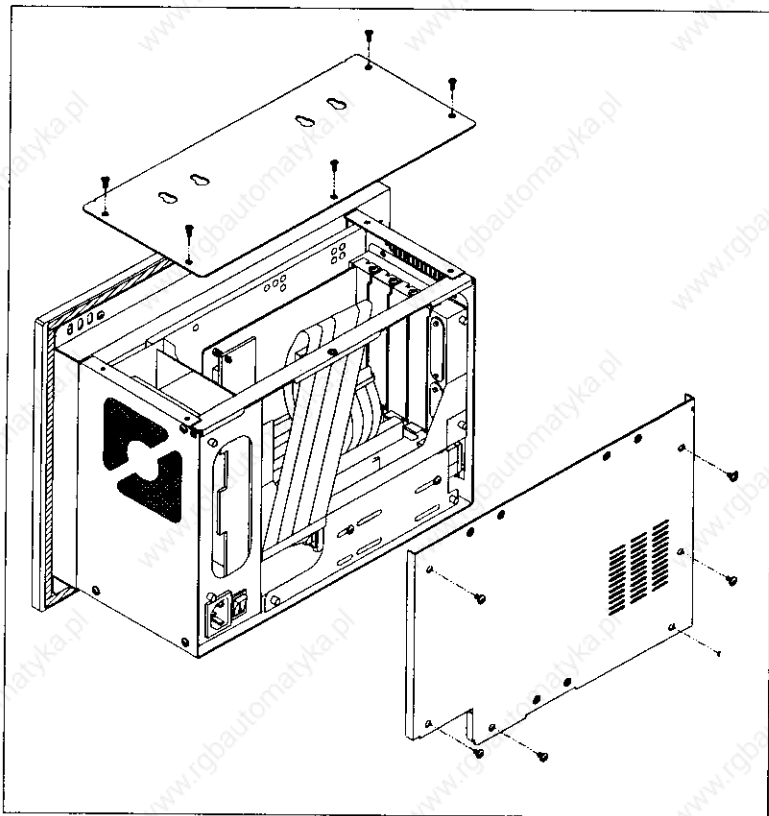

Figure 2-1: Removing the top cover and rear panel

2.3 Adding cards

The 4-slot passive backplane accepts half-size ISA-bus CPU and I/O cards. Slot number S4 has a little bit more space than the other slots. This slot lets you insert a CPU card with an on-board piggyback/PC-104 module. We strongly recommend these all-in-one cards, for they are durable and save valuable slot space by bundling a CPU with hard disk and floppy disk controllers, as well as serial and parallel ports.

At the side of the chassis, four bracket holes under the mounting bar match the four backplane slots. You will also find two smaller holes that you can use to install external D-type connectors.

When adding a card, slowly slide it in, carefully press it into the backplane socket and secure it with a screw to the top mounting bar. See Fig. 2-2. Refer to card manuals for wiring. Install additional cards. When you have finished, reattach the top cover and rear panel.

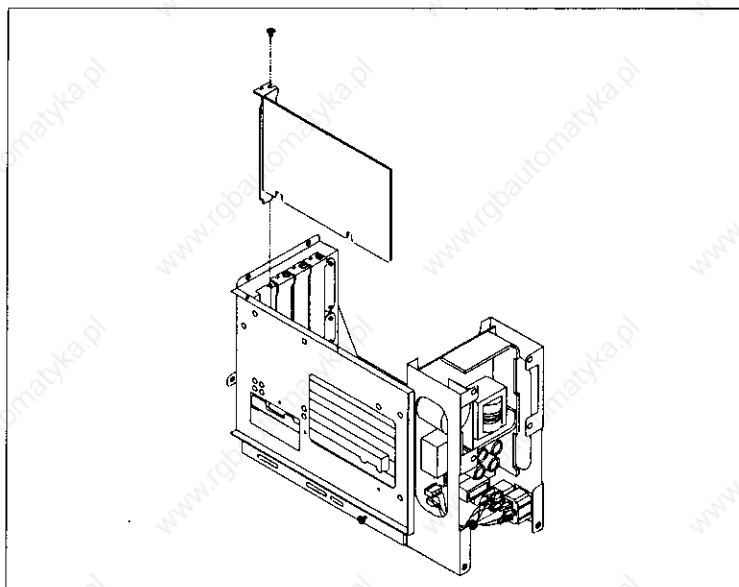

Figure 2-2: Installing add-on cards

2.4 Removing the protective cover

To reach the disk drives, power supply and monitor you must slide the main chassis out of its protective cover. First remove the top cover and rear panel as described in section 2.2.

Remove the three screws on the side panel just above the card brackets. Remove the two screws on the other side panel, below the fan. Remove the one screw on the bottom panel. Lastly, open the floppy disk door. Now you can slide out the main chassis completely.

Note: Remember to open the floppy drive door before you slide out the main chassis. The locking mechanism of the door is of a push-open and push-closed type.

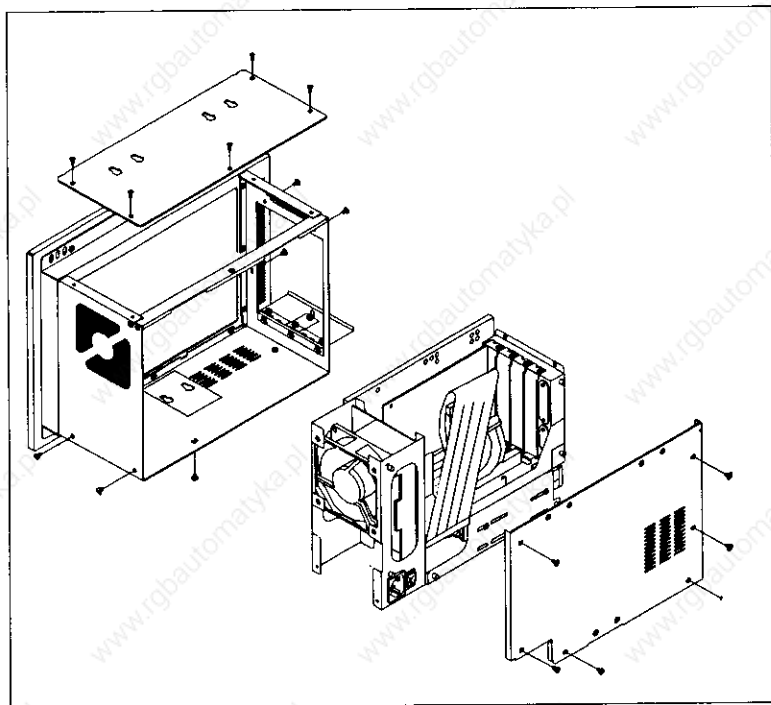

Figure 2-3: Slide out the main chassis

2.5 Installing optional drives

The MiPC-50 offers space for two disk drives. When you receive the station a 3½" floppy drive is already installed. Only the upper drive bay offers access through the floppy disk door. The lower position should therefore be reserved for an optional HDD.

To install the optional drive first remove the protective cover completely (see section 2.4). Use four screws to mount the disk drive in the disk drive bay under the existing floppy disk drive. Connect the power connector and controller ribbon cable. Slide the chassis back in its protective cover and secure it with screws on both sides and bottom.

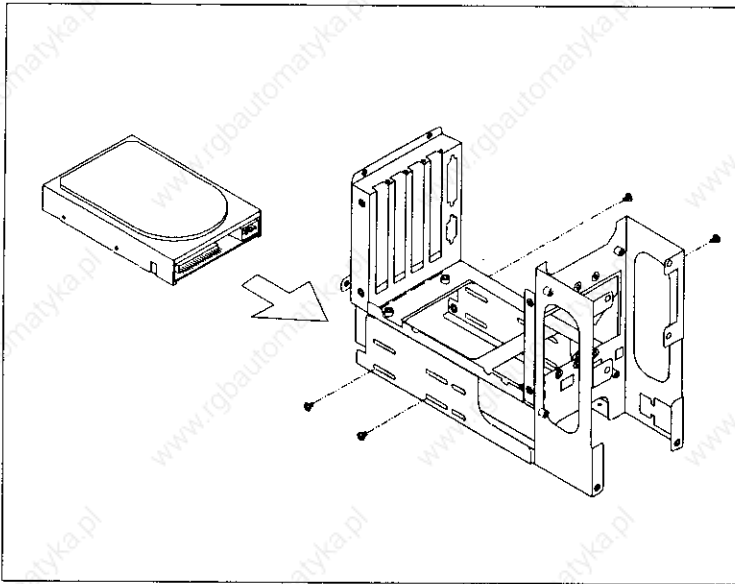

Figure 2-4: Installing an optional drive

CHAPTER
3

Maintenance

- **The passive backplane**
- **Power supply and cooling fan**
- **The flat panel display**
- **LCD backlight**

3.1 The passive backplane

Four screws secure the 4-slot passive backplane to the inside of the MiPC chassis.

To service or replace the backplane, remove the top cover. There is no need to slide the main chassis out. Remove the four screws that secure the backplane to the chassis. Lift the backplane up and remove the power cables.

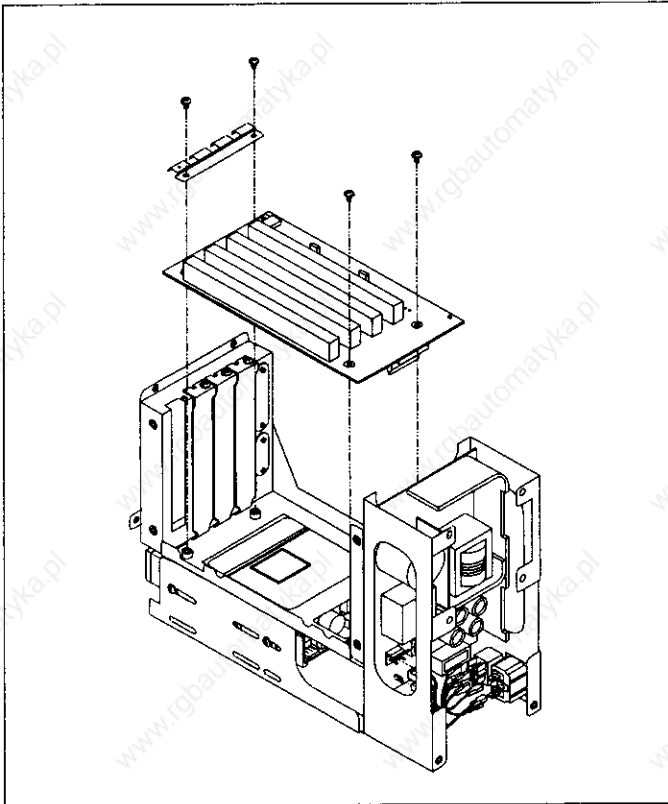

Figure 3-1: Detaching the passive backplane

3.2 Power supply and cooling fan

To service or replace the power supply and cooling fan, first remove the protective cover. (See section 2.4)

To reach the power supply you must first remove the cooling fan. Four screws connect the fan to the chassis. Unscrew the fan and disconnect its power cable.

A fuse, located at the lower left, protects the power supply. To detach the power supply from the chassis, disconnect the power cables and remove the four screws.

Warning: *Shut off all power to the MiPC-50 and unplug the power cables before you attempt to repair the power supply.*

For detailed power supply specifications refer to Appendix B.

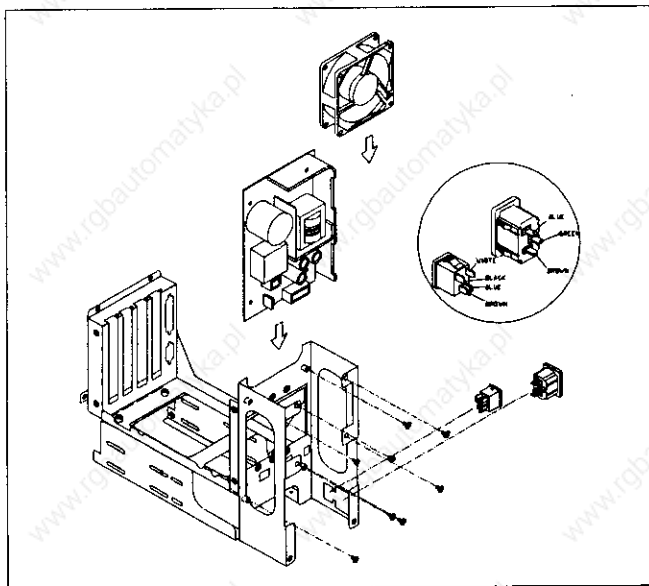

Figure 3-2: Removing cooling fan and power supply

3.3 The flat panel display

Your MiPC-50 has a 10.4" color TFT LCD or a 10.4" B/W LCD. Both displays connect to the MiPC-50 in exactly the same way.

To service the display, there is no need to remove the protective cover of the MiPC-50. You will only need to remove the front panel from the chassis. Disconnect the two display cables. One is a power cord and the other is a video adapter cable that connects the monitor with your display card. Finally, remove the four screws located on the corners of the display (See Figure 3-3).

Note: *We recommend that you leave display service and repair to your supplier. Contact Advantech's Customer Service Department for additional information on the displays.*

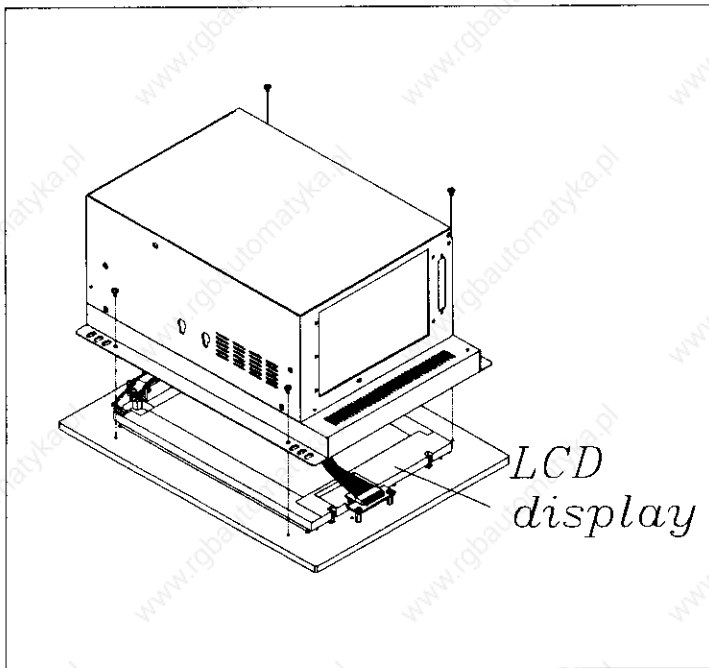

Figure 3-3: Disconnecting the display

3.4 LCD backlight

In the normal working life of the MiPC-50 you will seldom need to replace the LCD backlight. To do so, it is not necessary to open the rear and top panels. You only need to remove the four screws behind the front panel, detach the chassis, and then replace the LCD backlight.

Warning: *The backlight is small and fragile. Use caution when replacing.*

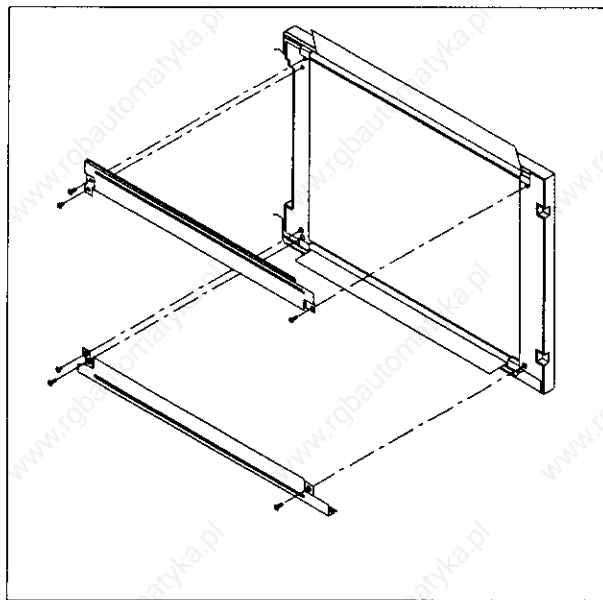

Figure 3-4: Replacing the LCD backlight (TFT display)

APPENDIX

A

Touchscreen

- **General information**
- **Specifications**
- **Environmental specifications**

A.1 General information

- 75% light transmission
- Advanced second-generation 5-wire resistive technology
- Enhanced visual resolution, antiglare surface treatment
- Enhanced scratch resistant hardcoat
- UL-recognized components (file no. E133802)
- When properly installed, ball impact compliance meets UL 1950 standard
- Fire Retardation Compliance meets UL-746c, 0.75" (19mm) flame test
- Systems incorporating these touchscreens, controllers, and cables have been approved to FCC class A and B compliance
- 5-wire touchscreens have an extremely long touch life of over 35 million touches.

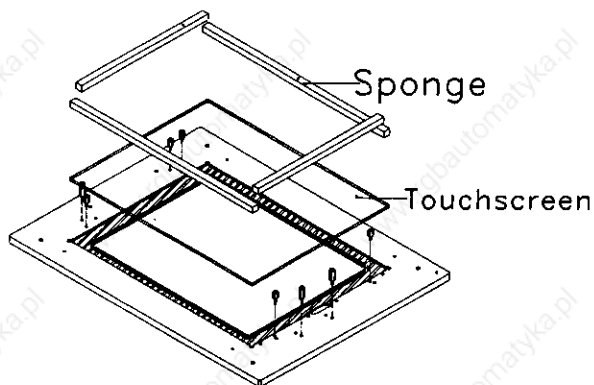

A.2 Specifications

- **Light transmission:** Typically 75% at 550 nanometer wavelength, optimized for flat-panel displays. All measurements per ASTM-D-10036-61.
- **Visual resolution:** antiglare - 6:1 minimum. Measured according to USAF 1951 Resolution Chart, under 30x magnification, with test unit located approximately 1.5"(3.8mm) from surface of resolution chart.
- **Haze:** Antiglare-less than 15% Per ASTM D 103-61
- **Gloss:** Antiglare-96+ gloss units, Per ASTM D 2457-70

A.3 Environmental specifications

- **Temperature**

Operating: -10°C to 50°C, and storage: -40°C to 71°C

- **Relative humidity**

Operating: 90RH at 35°C

Storage: 90RH at 35°C for 240 hours, noncondensing

- **Chemical Resistance**

The active area of the touchscreen is resistant to the following chemicals when exposed for a period of one hour at a temperature of 71°F (21°C)

- Acetone
- Methylene chloride
- Methyl ethyl ketone
- Isopropyl alcohol
- Hexane
- Ammonia-based glass cleaners
- Turpentine
- Mineral spirits
- Foods and beverages

APPENDIX **B**

Power Supply Specifications

- **Specifications of model MRW170**
- **Connector locations**
- **Input characteristics**
- **Output characteristics**
- **General specifications**
- **Input and output connectors**
- **Output power rating**
- **Dimensions**

B.1 Specifications of model MRW170

Model	Input		Output	(65 W max.)
MRW170	100-240V _{AC}	V1	+5 V @ 5.0 A	
		V2	+12 V @ 1.7 A	
		V3	-12 V @ 1.7 A	

Note 1: Conditions are nominal conditions unless otherwise specified.

- Nominal input
- Nominal output
- 25°C

Note 2: The primary FG and secondary FG are not connected with each other. It is recommended that both of them are connected with each other customer. All specifications are based on the conditions described in Note 1.

B.2 Connector locations

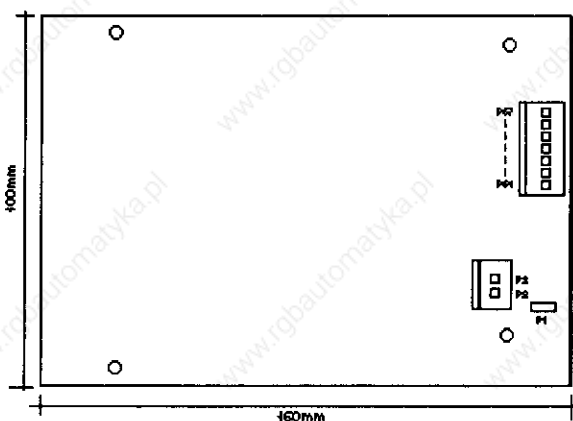

INPUT: CP1

P1	FG
----	----

INPUT: CP2

P2	LIVE
----	------

P3	NEUTRAL
----	---------

OUTPUT: CP51

P57	+12 V
-----	-------

P56	+5 V
-----	------

P55	+5 V
-----	------

P54	COMMON
-----	--------

P53	COMMON
-----	--------

P52	COMMON
-----	--------

P51	-12 V
-----	-------

B.3 Input characteristics

Specifications		Conditions
Nominal input voltage	100 - 200 VAC	
Input voltage range	85 - 264 VAC	
Input current	1.5 A typical, 1.7 A max.	100 VAC
	0.7 A typical, 0.9 A max.	240 VAC
Input fuse rating	3.15 A, 250 V	
Input frequency	50/60 Hz normal	Single phase
Brownout voltage	85 VAC	Typical load
Surge current	50 A max. @ 155 VAC	Typical load, 25°C cold start
	100 A max. @ 230 VAC	
Soft start circuitry	Thermistor limit	
Efficiency	70% typical	
Leakage current	0.5 mA max. @ 115 VAC	UL-method, 50-60 Hz
	0.75 mA max. @ 230 VAC	VDE-method two-pole disconnection 50-60 Hz
Switching frequency	100 KHz typical	
Circuit type	Flyback converter	

B.4 Output characteristics

		V1	V2	V3	Conditions	
Output voltage	nom.	V	5.0	12.0	-12.0	
Output current	min.	A	0.8	0.3	0.3	
	typ.	A	5.0	1.7	1.7	
	max.	A	7.0	2.5	2.5	
Output power	max.	W	65 W maximum			
Output voltage		V	5.00	12.0	-12.2	115 VAC at 25°C
Setpoint accuracy			±0.02	±0.20	±0.20	V1 : 5.0 A, V2: 1.7 A, V3: 1.7 A
Source effect	typ.	%	1.0	1.0	1.0	85-132 VAC, 180-264 VAC
Load effect	typ.	%	3.5	5	5	min. – typical load
Temperature effect	typ.	%	2.0	3.5	3.5	0°C - 50°C
Combined drift	max.	%	+4.0 -4.0	+8.0 -7.0	+8.0 -7.0	Source, load, temperature, cross-effect
Time drift	max.	%	0.5 (0.5 ~ 8 hours at 25°C)			
Cross effect	typ.	%		±5	±5	5 V load change for min to typ.
			±3		±5	12 V load change for min to typ.
			±3	±5		-12 V load change for min to typ.
Ripple	source max.	mVp-p	30	30	30	(See note 1)
	switching max.	mVp-p	50	50	50	(See note 1)
Ripple & noise	max.	mVp-p	150	250	250	(See note 1)
O.C. setting	min.	W	66			
O.V. setting		V	5.8~ 6.9	-	-	Shutdown type
Transient response (See Note 2)			±4% max, Recover time: 500 usec typ.			50~100% load
Startup time	typ.	ms	600			115 VAC input typical load
Holdup time		ms	20 typ. 15 min.			115 VAC input typical load

Note 1: Ripple and noise are specified at less than 20 MHz, nominal input voltage from minimum to typical load

Note 2: $T_r, T_f = 1 \text{ A}/\mu\text{sec}$

B.5 General specifications

Temperature	operating: 0 ~ 70°C storage: -40 ~ 75°C	power derating needed at 50~70°C
Humidity	operating and storage: 20~95% RH	Wet bulb temperature < 35°C noncondensing
Vibration	5 ~ 10 Hz, 10 mm amplitude 10 ~ 55 Hz, 2G acceleration	non-operating 1 hour for each (3) axis
Shock	20 G 11 ± 5 ms pulse duration	non-operating 1/2 sine wave pulse 3 shocks each axis
Dielectric strength	input-output: 2 KV _{AC} 1 minute 3.0 KV _{AC} (Y-capacitor removed) input-GND: 2 KV _{AC} 1 minute	
Isolation	Output-GND Input-GND Input-Output	500 V _{DC} and 100 MΩ min. (all combinations)
Safety standards	UL1950 recognized CSA Electrical Bulletin no. 234 level 3 EN60 950 (TÜV) approved	UL recognized at 40°C CSA certified at 40°C TÜV approved at 50°C
EMI	designed to meet FCC Class B VDE 0871 Class B	115 V _{AC} input 240 V _{AC} input
Dimensions	160mm (L) x 100mm (W) x 38mm (H)	See outline drawing
Weight	380g typical, 450g max.	
Mounting	four 4.0 mm holes on PWB	

B.6 Input and output connectors

Part no.	Header	Housing	Contact
CP1 (input)	Faston tab 250 series		Faston 250 series
CP2 (input)	Molex no. 10-31-1028 (5289-02A)	Molex no. 09-50-1021 (5199-02)	Molex no. 08-70-1031 (5194/5225)
CP51 (output)	Molex no. 09-56-2068 (5273-07A)	Molex no. 09-52-4064 (5195-07)	Molex no. 08-70-1018 (5194/5225)

B.7 Output power rating

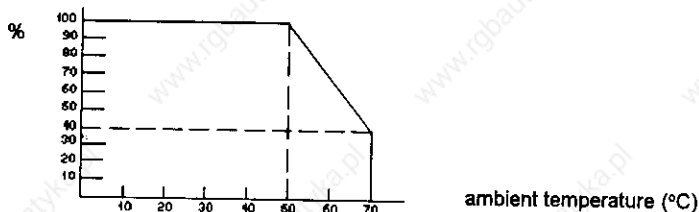

B.8 Dimensions

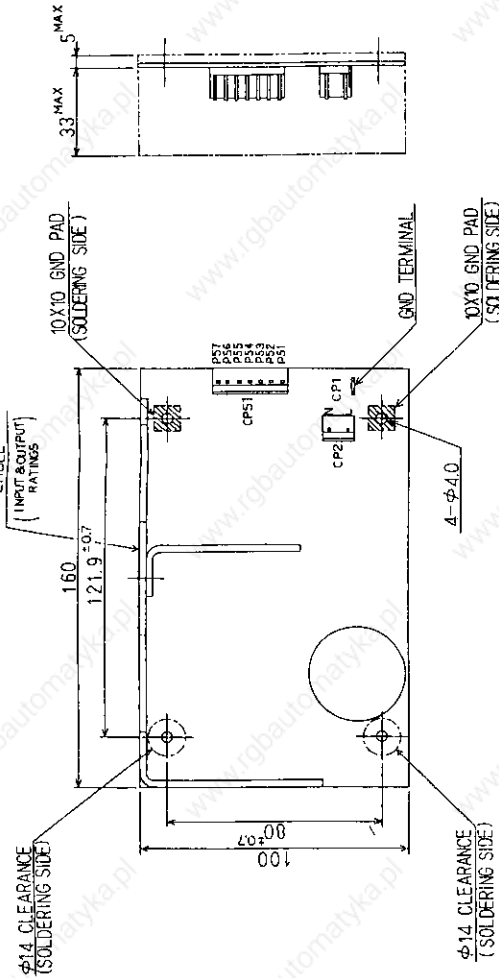

CP51: OUTPUT	P51	-12V
	P52	+12V
	P53	+5V
	P54	+5V
	P55	PS-1C COMMON
	P51	PS-2C COMMON
	P52	PS-2C COMMON
	P53	-12V
	P54	-12V
	P55	(MFR:TRKV)

CP1: AC INPUT	L	LINE
	N	NEUTRAL

NOTE : ± 1mm TOLERANCE UNLESS OTHERWISE SPECIFIED.

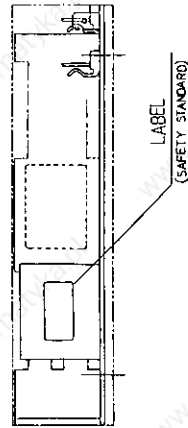

INPUT & OUTPUT RATINGS LABEL
MODEL: NRW10KV
AC INPUT: 100-240V, 50-60Hz
OUTPUT: 12V, 500mA, 2.0A, 2.0A, 2.0A
PS-1: 12V, 500mA, 2.0A, 2.0A, 2.0A
PS-2: 12V, 500mA, 2.0A, 2.0A, 2.0A
PS-3: 12V, 500mA, 2.0A, 2.0A, 2.0A
PS-4: 12V, 500mA, 2.0A, 2.0A, 2.0A
PS-5: 12V, 500mA, 2.0A, 2.0A, 2.0A
PS-6: 12V, 500mA, 2.0A, 2.0A, 2.0A
PS-7: 12V, 500mA, 2.0A, 2.0A, 2.0A
PS-8: 12V, 500mA, 2.0A, 2.0A, 2.0A
PS-9: 12V, 500mA, 2.0A, 2.0A, 2.0A
PS-10: 12V, 500mA, 2.0A, 2.0A, 2.0A
PS-11: 12V, 500mA, 2.0A, 2.0A, 2.0A
PS-12: 12V, 500mA, 2.0A, 2.0A, 2.0A
PS-13: 12V, 500mA, 2.0A, 2.0A, 2.0A
PS-14: 12V, 500mA, 2.0A, 2.0A, 2.0A
PS-15: 12V, 500mA, 2.0A, 2.0A, 2.0A
PS-16: 12V, 500mA, 2.0A, 2.0A, 2.0A
PS-17: 12V, 500mA, 2.0A, 2.0A, 2.0A
PS-18: 12V, 500mA, 2.0A, 2.0A, 2.0A
PS-19: 12V, 500mA, 2.0A, 2.0A, 2.0A
PS-20: 12V, 500mA, 2.0A, 2.0A, 2.0A
PS-21: 12V, 500mA, 2.0A, 2.0A, 2.0A
PS-22: 12V, 500mA, 2.0A, 2.0A, 2.0A
PS-23: 12V, 500mA, 2.0A, 2.0A, 2.0A
PS-24: 12V, 500mA, 2.0A, 2.0A, 2.0A
PS-25: 12V, 500mA, 2.0A, 2.0A, 2.0A
PS-26: 12V, 500mA, 2.0A, 2.0A, 2.0A
PS-27: 12V, 500mA, 2.0A, 2.0A, 2.0A
PS-28: 12V, 500mA, 2.0A, 2.0A, 2.0A
PS-29: 12V, 500mA, 2.0A, 2.0A, 2.0A
PS-30: 12V, 500mA, 2.0A, 2.0A, 2.0A
PS-31: 12V, 500mA, 2.0A, 2.0A, 2.0A
PS-32: 12V, 500mA, 2.0A, 2.0A, 2.0A
PS-33: 12V, 500mA, 2.0A, 2.0A, 2.0A
PS-34: 12V, 500mA, 2.0A, 2.0A, 2.0A
PS-35: 12V, 500mA, 2.0A, 2.0A, 2.0A
PS-36: 12V, 500mA, 2.0A, 2.0A, 2.0A
PS-37: 12V, 500mA, 2.0A, 2.0A, 2.0A
PS-38: 12V, 500mA, 2.0A, 2.0A, 2.0A
PS-39: 12V, 500mA, 2.0A, 2.0A, 2.0A
PS-40: 12V, 500mA, 2.0A, 2.0A, 2.0A
PS-41: 12V, 500mA, 2.0A, 2.0A, 2.0A
PS-42: 12V, 500mA, 2.0A, 2.0A, 2.0A
PS-43: 12V, 500mA, 2.0A, 2.0A, 2.0A
PS-44: 12V, 500mA, 2.0A, 2.0A, 2.0A
PS-45: 12V, 500mA, 2.0A, 2.0A, 2.0A
PS-46: 12V, 500mA, 2.0A, 2.0A, 2.0A
PS-47: 12V, 500mA, 2.0A, 2.0A, 2.0A
PS-48: 12V, 500mA, 2.0A, 2.0A, 2.0A
PS-49: 12V, 500mA, 2.0A, 2.0A, 2.0A
PS-50: 12V, 500mA, 2.0A, 2.0A, 2.0A
PS-51: 12V, 500mA, 2.0A, 2.0A, 2.0A
PS-52: 12V, 500mA, 2.0A, 2.0A, 2.0A
PS-53: 12V, 500mA, 2.0A, 2.0A, 2.0A
PS-54: 12V, 500mA, 2.0A, 2.0A, 2.0A
PS-55: 12V, 500mA, 2.0A, 2.0A, 2.0A
PS-56: 12V, 500mA, 2.0A, 2.0A, 2.0A
PS-57: 12V, 500mA, 2.0A, 2.0A, 2.0A
PS-58: 12V, 500mA, 2.0A, 2.0A, 2.0A
PS-59: 12V, 500mA, 2.0A, 2.0A, 2.0A
PS-60: 12V, 500mA, 2.0A, 2.0A, 2.0A
PS-61: 12V, 500mA, 2.0A, 2.0A, 2.0A
PS-62: 12V, 500mA, 2.0A, 2.0A, 2.0A
PS-63: 12V, 500mA, 2.0A, 2.0A, 2.0A
PS-64: 12V, 500mA, 2.0A, 2.0A, 2.0A
PS-65: 12V, 500mA, 2.0A, 2.0A, 2.0A
PS-66: 12V, 500mA, 2.0A, 2.0A, 2.0A
PS-67: 12V, 500mA, 2.0A, 2.0A, 2.0A
PS-68: 12V, 500mA, 2.0A, 2.0A, 2.0A
PS-69: 12V, 500mA, 2.0A, 2.0A, 2.0A
PS-70: 12V, 500mA, 2.0A, 2.0A, 2.0A
PS-71: 12V, 500mA, 2.0A, 2.0A, 2.0A
PS-72: 12V, 500mA, 2.0A, 2.0A, 2.0A
PS-73: 12V, 500mA, 2.0A, 2.0A, 2.0A
PS-74: 12V, 500mA, 2.0A, 2.0A, 2.0A
PS-75: 12V, 500mA, 2.0A, 2.0A, 2.0A
PS-76: 12V, 500mA, 2.0A, 2.0A, 2.0A
PS-77: 12V, 500mA, 2.0A, 2.0A, 2.0A
PS-78: 12V, 500mA, 2.0A, 2.0A, 2.0A
PS-79: 12V, 500mA, 2.0A, 2.0A, 2.0A
PS-80: 12V, 500mA, 2.0A, 2.0A, 2.0A
PS-81: 12V, 500mA, 2.0A, 2.0A, 2.0A
PS-82: 12V, 500mA, 2.0A, 2.0A, 2.0A
PS-83: 12V, 500mA, 2.0A, 2.0A, 2.0A
PS-84: 12V, 500mA, 2.0A, 2.0A, 2.0A
PS-85: 12V, 500mA, 2.0A, 2.0A, 2.0A
PS-86: 12V, 500mA, 2.0A, 2.0A, 2.0A
PS-87: 12V, 500mA, 2.0A, 2.0A, 2.0A
PS-88: 12V, 500mA, 2.0A, 2.0A, 2.0A
PS-89: 12V, 500mA, 2.0A, 2.0A, 2.0A
PS-90: 12V, 500mA, 2.0A, 2.0A, 2.0A
PS-91: 12V, 500mA, 2.0A, 2.0A, 2.0A
PS-92: 12V, 500mA, 2.0A, 2.0A, 2.0A
PS-93: 12V, 500mA, 2.0A, 2.0A, 2.0A
PS-94: 12V, 500mA, 2.0A, 2.0A, 2.0A
PS-95: 12V, 500mA, 2.0A, 2.0A, 2.0A
PS-96: 12V, 500mA, 2.0A, 2.0A, 2.0A
PS-97: 12V, 500mA, 2.0A, 2.0A, 2.0A
PS-98: 12V, 500mA, 2.0A, 2.0A, 2.0A
PS-99: 12V, 500mA, 2.0A, 2.0A, 2.0A
PS-100: 12V, 500mA, 2.0A, 2.0A, 2.0A

SER. NO. STAMP (EXAMPLE FOR NRW10KV)