

## Dual Operational Amplifier with Darlington Input

**TBC 2332**  
**TBE 2335**

### Features

- High input impedance
- Wide common-mode range
- Large supply voltage range
- Large control range
- Wide temperature range (TBC 2332 B)
- Open collector output
- NPN Darlington input
- Low input current
- Internally frequency-compensated

### Applications

- Amplifier
- Comparator
- Level converter
- Impedance converter
- Driver

**Bipolar IC**

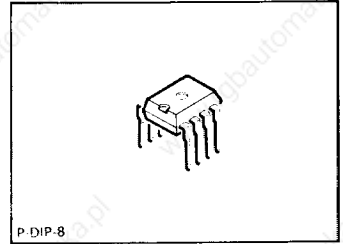

### Pin Configuration (top view)

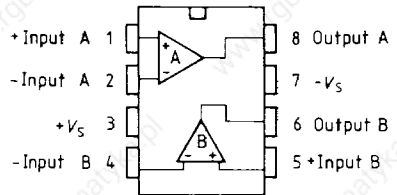

Type	Ordering Code	Package
☒ TBC 2332 B	Q67000-A2500	P-DIP-8
☒ TBE 2335 B	Q67000-A1165	P-DIP-8

These op amps are economic and versatile. Owing to their excellent performance qualities, they are well suited for a wide scope of applications, as in measurement and control engineering, automotive electronics, AF circuits, analog computers, etc. The low input current of these amplifiers is particularly advantageous for measurement and control systems.

**Circuit Diagram of one Op Amp**

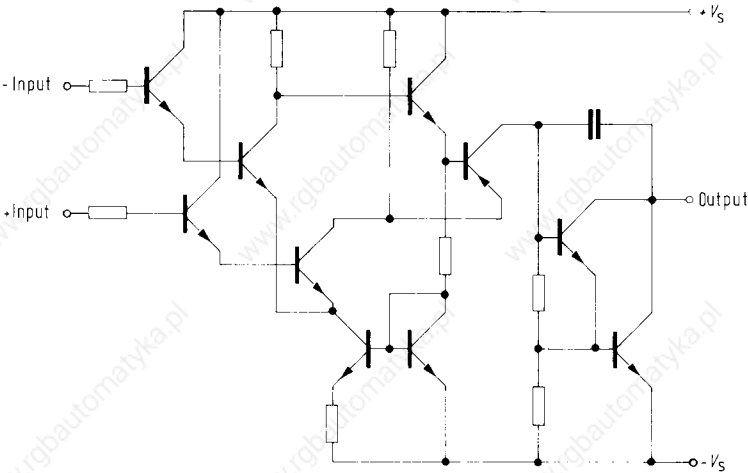

**Absolute Maximum Ratings (TBC 2332)**

Parameter	Symbol	Limit Values	Unit
Supply voltage	$V_S$	$\pm 15$	V
Output current	$I_Q$	70	mA
Differential input voltage $V_S = \pm 13$ to $\pm 15$ V $V_S = \pm 2$ to $\pm 13$ V	$V_{ID}$ $V_{ID}$	$\pm 13$ $\pm V_S$	V
Junction temperature	$T_j$	150	$^{\circ}\text{C}$
Storage temperature range	$T_{stg}$	-55 to 125	$^{\circ}\text{C}$
Thermal resistance system – air	$R_{th SA}$	100	K/W

**Operating Range (TBC 2332)**

Supply voltage	$V_S$	$\pm 2$ to $\pm 15$	V
Ambient temperature	$T_A$	-55 to 125	$^{\circ}\text{C}$

**Characteristics (TBC 2332)**
 $V_S = \pm 5 \text{ V to } \pm 15 \text{ V}$ 

Parameter	Symbol	Limit Values $T_A = 25^\circ\text{C}$			Limit Values $T_A = -55$ to $125^\circ\text{C}$		Unit
		min.	typ.	max.	min.	max.	
Open-loop supply current consumption, total	$I_S$		0.5	1.5		1.5	mA
Input offset voltage $R_G = 50 \Omega$	$V_{IO}$	-10		10	-15	15	mV
Input offset current	$I_{IO}$	-5		5	-10	10	nA
Input current	$I_I$		5	15		25	nA
Control range							
$R_L = 2 \text{ k}\Omega$ , $V_S = \pm 15 \text{ V}$	$V_{Q \text{ pp}}$	14.9		-14	14.8	-14	V
$R_L = 620 \Omega$ , $V_S = \pm 15 \text{ V}$	$V_{Q \text{ pp}}$	14.9		-12.5	14.8	-12	V

**Characteristics (TBC 2332)**
 $V_S = \pm 5 \text{ V to } \pm 15 \text{ V}$ ;  $R_L = 2 \text{ k}\Omega$ , unless otherwise specified

Parameter	Symbol	Limit Values $T_A = 25^\circ\text{C}$			Limit Values $T_A = -55$ to $125^\circ\text{C}$		Unit
		min.	typ.	max.	min.	max.	
Input impedance $f = 1 \text{ kHz}$	$Z_i$		3				M $\Omega$
Open-loop voltage gain $f = 100 \text{ Hz}$	$G_{V0}$	80	83		75		dB
$R_L = 10 \text{ k}\Omega$ , $f = 100 \text{ Hz}$	$G_{V0}$		88				dB
Output reverse current	$I_{QR}$			1		5	$\mu\text{A}$
Common-mode input voltage range	$V_{IC}$	$V_S$		$-V_S + 2.0$	$V_S$	$-V_S + 3$	V
Common-mode rejection	$k_{CMR}$	75	80		70		dB
Supply voltage rejection $G_V = 100$	$k_{SVR}$		25	100		100	$\mu\text{V/V}$
Temperature coefficient of $V_{IO}$ $R_G = 50 \Omega$	$\alpha_{VIO}$		4	25		50	$\mu\text{V/K}$
Temperature coefficient of $I_{IO}$ $R_G = 50 \Omega$	$\alpha_{IIO}$		50				pA/K
Output saturation voltage $I_Q = 10 \text{ mA}$	$V_{Q \text{ sat}}$			1			V
Slew rate for non-inverting operation <sup>1)</sup>	SR		0.5				V/ $\mu\text{s}$
Slew rate for inverting operation <sup>1)</sup>	SR		0.5				V/ $\mu\text{s}$

<sup>1)</sup> For the relationship between power bandwidth and slew rate refer to "Introduction to Operational Amplifiers"

**Absolute Maximum Ratings (TBE 2335)**

Parameter	Symbol	Limit Values	Unit
Supply voltage	$V_S$	$\pm 15$	V
Output current	$I_Q$	70	mA
Differential input voltage $V_S = \pm 13$ to $\pm 15$ V $V_S = \pm 2$ to $\pm 13$ V	$V_{ID}$ $V_{ID}$	$\pm 13$ $\pm V_S$	V
Junction temperature	$T_j$	150	$^{\circ}\text{C}$
Storage temperature range	$T_{stg}$	-55 to 125	$^{\circ}\text{C}$
Thermal resistance system – air	$R_{th SA}$	100	K/W

**Operating Range (TBE 2335)**

Supply voltage	$V_S$	$\pm 2$ to $\pm 15$	V
Ambient temperature	$T_A$	-25 to 85	$^{\circ}\text{C}$

**Characteristics (TBE 2335)**

$V_S = \pm 2$  V,  $R_L = 2$  k $\Omega$

Parameter	Symbol	Limit Values $T_A = 25^{\circ}\text{C}$			Limit Values $T_A = -55$ to $125^{\circ}\text{C}$		Unit
		min.	typ.	max.	min.	max.	
Input offset voltage $R_G = 50 \Omega$	$V_{IO}$	-10		10	-15	15	mV
Input offset current	$I_{IO}$	-5		5	-10	10	nA
Input current	$I_I$		5	15		25	nA
Open-loop voltage gain $f = 100$ Hz	$G_{V0}$	75			70		dB

**Characteristics (TBE 2335)**

$V_S = \pm 5$  V to  $\pm 15$  V;  $R_L = 2$  k $\Omega$ , unless otherwise specified

Parameter	Symbol	Limit Values $T_A = 25^{\circ}\text{C}$			Limit Values $T_A = -25$ to $85^{\circ}\text{C}$		Unit
		min.	typ.	max.	min.	max.	
Open-loop supply current consumption, total	$I_S$		0.5	1.5		1.5	mA
Input offset voltage $R_G = 50 \Omega$	$V_{IO}$	-15		15	-18	18	mV
Input offset current	$I_{IO}$	-10		10	-20	20	nA
Input current	$I_I$		5	25		35	nA
Control range $V_S = \pm 15$ V	$V_{Q PP}$	14.9		-14	14.8	-14	V
$R_L = 620 \Omega$ , $V_S = \pm 15$ V	$V_{Q PP}$	14.9		-12.5	14.8	-12	V

**Characteristics (TBE 2335)**

$V_S = \pm 5 \text{ V to } \pm 15 \text{ V}$ ;  $R_L = 2 \text{ k}\Omega$ ,  
unless otherwise specified

Parameter	Symbol	Limit Values $T_A = 25^\circ\text{C}$			Limit Values $T_A = -25$ to $85^\circ\text{C}$		Unit
		min.	typ.	max.	min.	max.	
Input impedance $f = 1 \text{ kHz}$	$Z_i$		3				M $\Omega$
Open-loop voltage gain $f = 100 \text{ Hz}$ $R_L = 10 \text{ k}\Omega$ , $f = 100 \text{ Hz}$	$G_{V0}$ $G_{V0}$	75	80 85		75		dB dB
Output reverse current	$I_{QR}$			10		20	$\mu\text{A}$
Common-mode input voltage range	$V_{IC}$	$-V_S + 2.0$		$V_S - 0.5$	$-V_S + 3$	$-V_S - 0.8$	V
Common-mode rejection	$K_{CMR}$	70	78		70		dB
Supply voltage rejection $G_V = 100$	$K_{SVR}$		25	100		100	$\mu\text{V/V}$
Temperature coefficient of $V_{IO}$ $R_G = 50 \Omega$	$\alpha_{VIO}$		4	25		50	$\mu\text{V/K}$
Temperature coefficient of $I_{IO}$ $R_G = 50 \Omega$	$\alpha_{IIO}$		50				$\mu\text{A/K}$
Output saturation voltage $I_Q = 10 \text{ mA}$	$V_{Q \text{ sat}}$			1			V
Slew rate for non-inverting operation <sup>1)</sup>	SR		0.5				V/ $\mu\text{s}$
Slew rate for inverting operation <sup>1)</sup>	SR		0.5				V/ $\mu\text{s}$

**Characteristics (TBE 2335)**

$V_S = \pm 2 \text{ V}$ ,  $R_L = 2 \text{ k}\Omega$

Input offset voltage $R_G = 50 \Omega$	$V_{IO}$	-17		17	-20	20	mV
Input offset current	$I_{IO}$	-10		10	-20	20	nA
Input current	$I_i$		5	25		35	nA
Open-loop voltage gain $f = 100 \text{ Hz}$	$G_{V0}$	70			70		dB

<sup>1)</sup> For the relationship between power bandwidth and slew rate refer to **“Introduction to Operational Amplifiers”**