

Up to PL e of EN ISO 13849-1 PZE X4.1P



Contact expansion module for increasing the number of available contacts

Approvals

	PZE X4.1P
	◆
	◆
	◆

Unit features

- ▶ Positive-guided relay outputs:
 - 4 safety contacts (N/O), instantaneous
- ▶ Safe separation of safety contacts 13-14, 23-24, 33-34 from input circuits K1-U-K2 and feedback loop Y1-Y2
- ▶ LED indicator for:
 - Switch status channel 1/2
 - Supply voltage
- ▶ Plug-in connection terminals (either spring-loaded terminal or screw terminal)
- ▶ Suitable to be driven via a semiconductor output
- ▶ See order reference for unit types

Unit description

The unit meets the requirements of EN 60204-1 and IEC 60204-1. The contact expansion module is used to increase the number of contacts available on a base unit. Base units are all

- ▶ Safety relays with feedback loop
- ▶ Programmable safety systems with feedback loop
- ▶ Units with OSSD semiconductor outputs and feedback loop

The category that can be achieved in accordance with EN 954-1 and EN ISO 13849-1 depends on the category of the base unit. The contact expansion module may not exceed this.

Safety features

The unit meets the following safety requirements:

- ▶ The contact expansion module expands an existing circuit. As the output relays are monitored via the base unit's feedback loop, the safety functions on the existing circuit are transferred to the contact expansion module.
- ▶ The safety function remains effective in the case of a component failure.
- ▶ Earth fault in the feedback loop: Detected, depending on the base unit that is used.
- ▶ Earth fault in the input circuit: The output relays de-energise and the safety contacts open.

Block diagram

* Safe separation in accordance with EN 60947-1, 6 kV (see unit features)

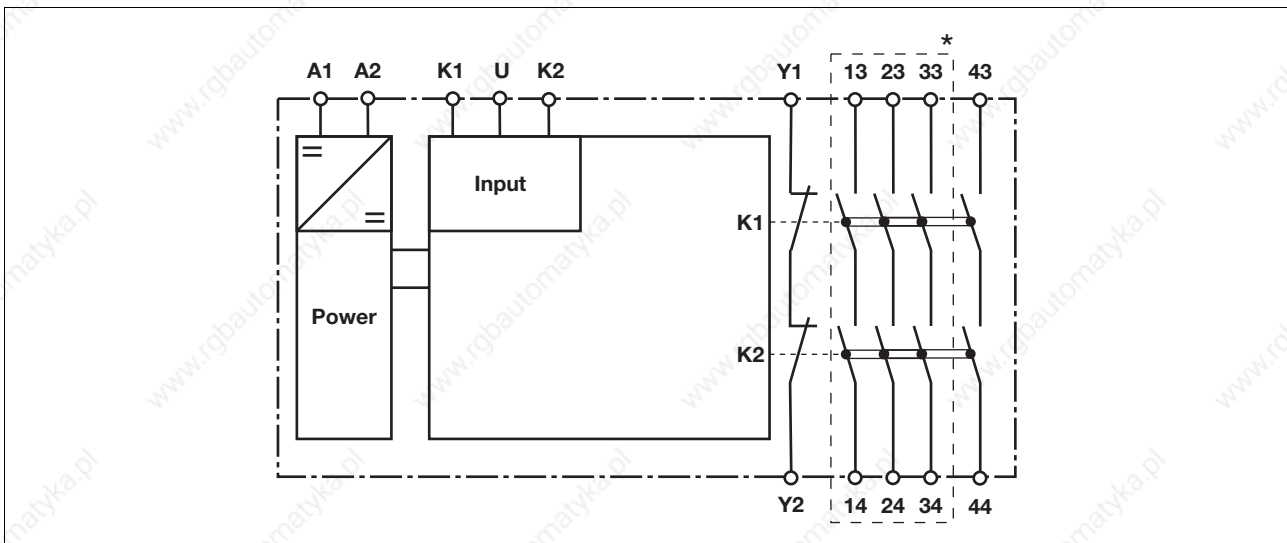

Up to PL e of EN ISO 13849-1 PZE X4.1P

Function description

- ▶ Single-channel operation: one input circuit affects both output relays
- ▶ Dual-channel operation:
 - two redundant input circuits affect one output relay
- Detection of shorts across contacts only possible with pulsed inputs

Timing diagram

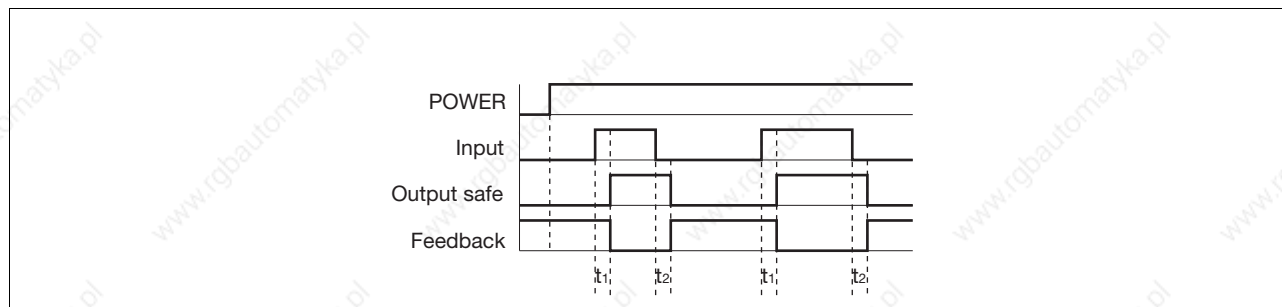

Key

- ▶ Power: Supply voltage
- ▶ Input: Input circuits K1-U-K2
- ▶ Output safe: Safety contacts 13-14, 23-24, 33-34, 43-44
- ▶ Feedback: Feedback loop Y1-Y2
- ▶ t_1 : Switch-on delay
- ▶ t_2 : Delay-on de-energisation

Wiring

Please note:

- ▶ Information given in the “Technical details” must be followed.
- ▶ Outputs 13-14, 23-24, 33-34, 43-44 are safety contacts.
- ▶ To prevent contact welding, a fuse should be connected before the output contacts (see technical details).
- ▶ Calculation of the max. cable runs l_{max} in the input circuit:

$$l_{max} = \frac{R_{lmax}}{R_l / km}$$

R_{lmax} = max. overall cable resistance (see technical details)

R_l / km = cable resistance/km

- ▶ Use copper wire that can withstand 60/75 °C.
- ▶ Sufficient fuse protection must be provided on all output contacts with capacitive and inductive loads.

Up to PL e of EN ISO 13849-1 PZE X4.1P

Preparing for operation

► Supply voltage

Supply voltage	AC	DC
Only when driven via safety relay with safety contacts		

► Input circuit

Input circuit	Single-channel	Dual-channel
Base unit: PNOZ X safety relay Driven via safety contacts		
Base unit: PNOZelog safety relay, programmable safety system or PNOZmulti Driven via safe semiconductor outputs (24 VDC)		

► Feedback loop

Feedback loop	Base unit: PNOZ X safety relay	Base unit: PNOZelog safety relay, programmable safety system or PNOZmulti
Y1, Y2 and Input are inputs on the base unit; they evaluate the feedback loop		

Up to PL e of EN ISO 13849-1 PZE X4.1P

Terminal configuration

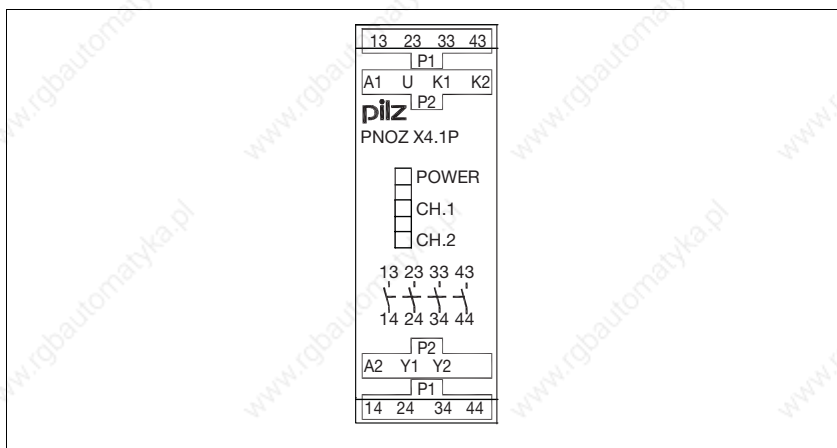

Installation

- ▶ The safety relay should be installed in a control cabinet with a protection type of at least IP54.
- ▶ Use the notch on the rear of the unit to attach it to a DIN rail.
- ▶ Ensure the unit is mounted securely on a vertical DIN rail (35 mm) by using a fixing element (e.g. retaining bracket or an end angle).

Dimensions

* with spring-loaded terminals

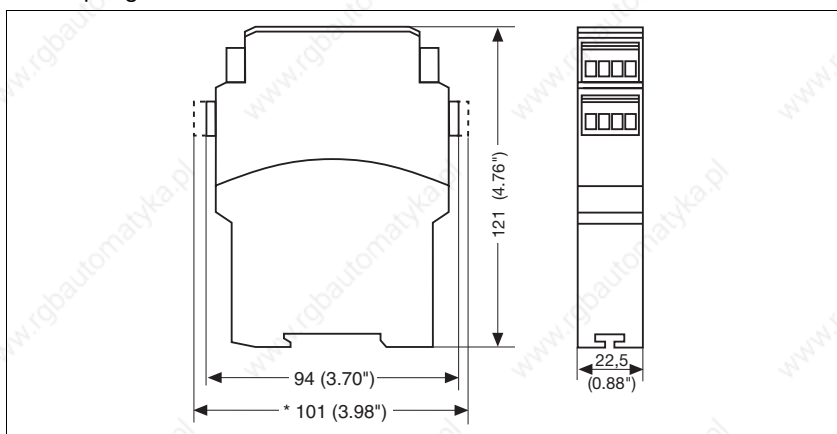

Up to PL e of EN ISO 13849-1 PZE X4.1P

Notice

This data sheet is only intended for use during configuration. For installation and operation, please refer to the operating instructions supplied with the unit.

Service life graph

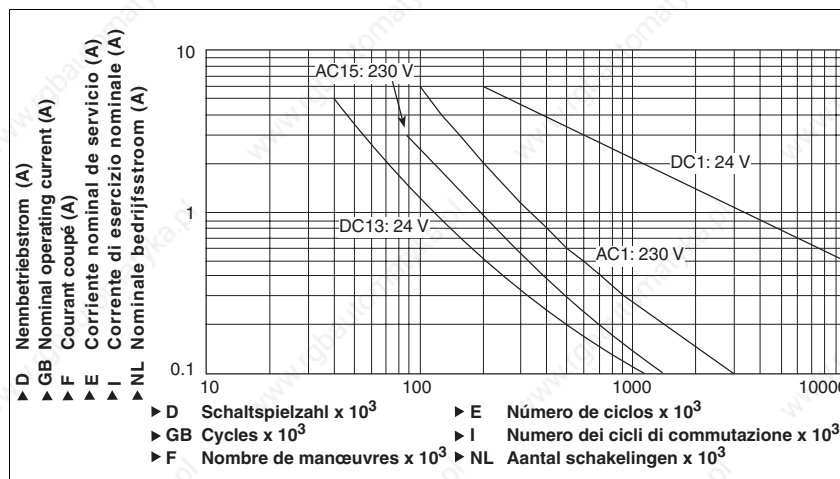

Technical details

Electrical data

Supply voltage	
Supply voltage U_B DC	24 V
Voltage tolerance	-15 %/+10 %
Power consumption at U_B DC	2.5 W
Residual ripple DC	20 %
Voltage and current at	
Input circuit DC: 24.0 V	35.0 mA
Number of output contacts	
Safety contacts (S) instantaneous:	4
Utilisation category in accordance with EN 60947-4-1	
Safety contacts: AC1 at 240 V	$I_{min}: 0.01 A, I_{max}: 6.0 A$ $P_{max}: 1500 VA$
Safety contacts: DC1 at 24 V	$I_{min}: 0.01 A, I_{max}: 6.0 A$ $P_{max}: 150 W$
Utilisation category in accordance with EN 60947-5-1	
Safety contacts: AC15 at 230 V	$I_{max}: 3.0 A$
Safety contacts: DC13 at 24 V (6 cycles/min)	$I_{max}: 4.0 A$
Contact material	AgCuNi + 0.2 µm Au
External contact fuse protection ($I_k = 1 kA$) to EN 60947-5-1	
Blow-out fuse, quick	
Safety contacts:	6 A
Blow-out fuse, slow	
Safety contacts:	4 A
Circuit breaker 24 VAC/DC, characteristic B/C	
Safety contacts:	4 A
Max. overall cable resistance R_{lmax} per input circuit	
single-channel at U_B DC	30 Ohm
dual-channel without detect. of shorts across contacts at U_B DC	60 Ohm

Up to PL e of EN ISO 13849-1 PZE X4.1P

Safety-related characteristic data	
PL in accordance with EN ISO 13849-1	PL e (Cat. 4)
Category in accordance with EN 954-1	Cat. 4
SIL CL in accordance with EN IEC 62061	SIL CL 3
PFH in accordance with EN IEC 62061	2.31E-09
SIL in accordance with IEC 61511	SIL 3
PFD in accordance with IEC 61511	2.03E-06
t _M in years	20
Times	
Switch-on delay	
with automatic reset typ.	13 ms
with automatic reset max.	20 ms
with automatic reset after power on typ.	16 ms
with automatic reset after power on max.	30 ms
Delay-on de-energisation	
with E-STOP typ.	10 ms
with E-STOP max.	20 ms
with power failure typ.	58 ms
with power failure max.	80 ms
Supply interruption before de-energisation	20 ms
Supply interruption before de-energisation in the input circuit	2.5 ms
Environmental data	
EMC	EN 60947-5-1, EN 61000-6-2, EN 61000-6-4
Vibration to EN 60068-2-6	
Frequency	10 - 55 Hz
Amplitude	0.35 mm
Climatic suitability	EN 60068-2-78
Airgap creepage in accordance with EN 60947-1	
Pollution degree	2
Overvoltage category	III
Rated insulation voltage	250 V
Rated impulse withstand voltage	6.00 kV
Ambient temperature	-10 - 55 °C
Storage temperature	-40 - 85 °C
Protection type	
Mounting (e.g. cabinet)	IP54
Housing	IP40
Terminals	IP20
Mechanical data	
Housing material	
Housing	PPO UL 94 V0
Front	ABS UL 94 V0
Cross section of external conductors with screw terminals	
1 core flexible	0.25 - 2.50 mm ² , 24 - 12 AWG Order no.: 777587
2 core, same cross section, flexible:	
with crimp connectors, without insulating sleeve	0.25 - 1.00 mm ² , 24 - 16 AWG Order no.: 777587
without crimp connectors or with TWIN crimp connectors	0.20 - 1.50 mm ² , 24 - 16 AWG Order no.: 777587
Torque setting with screw terminals	0.50 Nm Order no.: 777587
Cross section of external conductors with spring-loaded terminals: Flexible with/without crimp connectors	0.20 - 1.50 mm ² , 24 - 16 AWG Order no.: 787587
Spring-loaded terminals: Terminal points per connection	2 Order no.: 787587
Stripping length	8 mm Order no.: 787587

Up to PL e of EN ISO 13849-1 PZE X4.1P

Mechanical data

Dimensions	
Height	101.0 mm Order no.: 787587 94.0 mm Order no.: 777587
Width	22.5 mm
Depth	121.0 mm
Weight	180 g Order no.: 787587 185 g Order no.: 777587

The standards current on **2008-12** apply.

Conventional thermal current

I_{th} (A) at U_B DC

1 contact	6.00 A
2 contacts	6.00 A
3 contacts	4.50 A
4 contacts	3.50 A

Order reference

Type	Features	Terminals	Order no.
PZE X4.1P C	24 VDC	Spring-loaded terminals	787 587
PZE X4.1P	24 VDC	Screw terminals	777 587