

## General information

### IGBT STACK for typical voltage of up to 400V Rated output current 217A

- Solar power
- Motor drivers
- 62mm IGBT power module
- Trenchstop™ IGBT 4

Topology	B6I
Application	Inverter
Load type	Resistive, inductive
Semiconductor (Inverter Section)	3 x FF450R12KE4
DC Link	2.4 mF
Heatsink	Forced air cooled (fan not included)
Implemented sensors	Current, voltage, temperature
Driver signals IGBT	Electrical
Design standards	EN 50178
Sales - name	6PS04512E43G37986
SP - No.	SP001046792

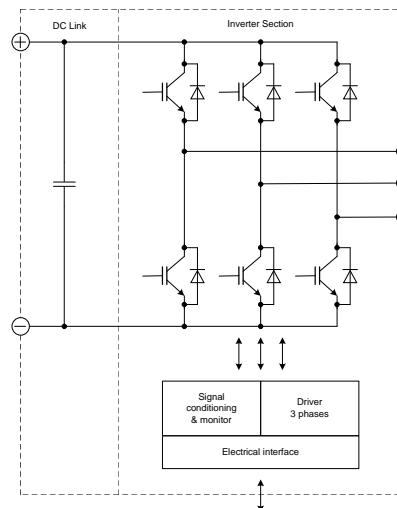
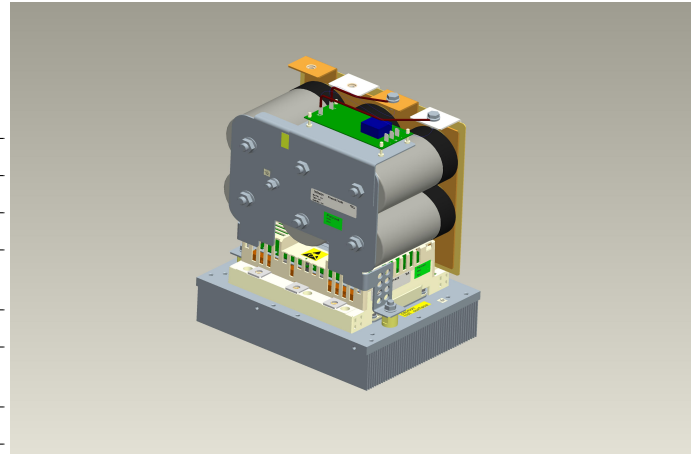

prepared by: OW	date of publication: 2013-10-18
approved by: AR	revision: 2.2

# Technical Information

PrimeSTACK™

# 6PS04512E43G37986



Preliminary data

## Absolute maximum rated values

Collector-emitter voltage	IGBT; $T_{vj} = 25^{\circ}\text{C}$	$V_{CES}$	1200	V
Repetitive peak reverse voltage	Diode; $T_{vj} = 25^{\circ}\text{C}$	$V_{RRM}$	1200	V
DC link voltage	IGBT not switching	$V_{DC}$	900	V
Insulation management	according to installation height of 2000 m	$V_{line}$	500	$V_{RMS}$
Insulation test voltage	according to EN 50178, $f = 50\text{ Hz}$ , $t = 1\text{ s}$	$V_{ISOL}$	2	$kV_{RMS}$
Repetitive peak collector current inverter section (IGBT)	$t_p = 1\text{ ms}$	$I_{CRM2}$	900	A
Repetitive peak forward current inverter section (Diode)	$t_p = 1\text{ ms}$	$I_{FRM2}$	900	A
Continuous current inverter section		$I_{AC2}$	270	$A_{RMS}$
Junction temperature	under switching conditions	$T_{vjop}$	150	$^{\circ}\text{C}$
Switching frequency inverter section		$f_{sw2}$	14	kHz

### Notes

Further maximum ratings are specified in the following dedicated sections

## Characteristic values

### DC Link

			min.	typ.	max.	
Rated voltage		$V_{DC}$		600	850	V
Over voltage shutdown	within 1000 $\mu\text{s}$			850		V
Capacitor	1 s, 6 p	$C_{DC}$		2.4		mF
Maximum ripple current	per device, $T_{amb} = 55^{\circ}\text{C}$	$I_{ripple}$		49		$A_{RMS}$
Balance or discharge resistor	per DC link unit	$R_b$		164		$k\Omega$

### Inverter Section

			min.	typ.	max.	
Rated continuous current	$V_{DC} = 600\text{ V}$ , $V_{AC} = 400\text{ V}_{RMS}$ , $\cos(\varphi) = 0.85$ , $f_{AC\ sine} = 50\text{ Hz}$ , $f_{sw} = 5000\text{ Hz}$ , $T_{inlet} = 40^{\circ}\text{C}$ , $T_j \leq 125^{\circ}\text{C}$	$I_{AC}$		265		$A_{RMS}$
Over current shutdown	within 15 $\mu\text{s}$	$I_{AC\ OC}$		626		$A_{peak}$
Power losses	$I_{AC} = 265\text{ A}$ , $V_{DC} = 600\text{ V}$ , $V_{AC} = 400\text{ V}_{RMS}$ , $\cos(\varphi) = 0.85$ , $f_{AC\ sine} = 50\text{ Hz}$ , $f_{sw} = 5000\text{ Hz}$ , $T_{inlet} = 40^{\circ}\text{C}$ , $T_j \leq 125^{\circ}\text{C}$	$P_{loss}$		2275		W

### Inverter Section (specific condition)

			min.	typ.	max.	
Specific continuous current	$V_{DC} = 750\text{ V}$ , $V_{AC} = 400\text{ V}_{RMS}$ , $\cos(\varphi) = 0.8$ , $f_{AC\ sine} = 50\text{ Hz}$ , $f_{sw} = 5000\text{ Hz}$ , $T_{inlet} = 40^{\circ}\text{C}$ , $T_j \leq 125^{\circ}\text{C}$	$I_{ACsp}$		217		$A_{RMS}$
Continuous current at low frequency	$V_{DC} = 750\text{ V}$ , $V_{AC} = 400\text{ V}_{RMS}$ , $\cos(\varphi) = 0.8$ , $f_{AC\ sine} = 0\text{ Hz}$ , $f_{sw} = 5000\text{ Hz}$ , $T_{inlet} = 40^{\circ}\text{C}$ , $T_j \leq 125^{\circ}\text{C}$	$I_{ACsp}$		105		$A_{RMS}$
Specific continuous current for 150% overload capability	$I_{AC\ 150\%} = 263\text{ A}_{RMS}$ , $t_{on\ over} = 3\text{ s}$ , $T_j \leq 125^{\circ}\text{C}$	$I_{ACsp\ over1}$		175		$A_{RMS}$
Specific continuous current for 150% overload capability	$I_{AC\ 150\%} = 229\text{ A}_{RMS}$ , $t_{on\ over} = 60\text{ s}$ , $T_j \leq 125^{\circ}\text{C}$	$I_{ACsp\ over2}$		152		$A_{RMS}$
Power losses	$I_{AC} = 217\text{ A}$ , $V_{DC} = 750\text{ V}$ , $V_{AC} = 400\text{ V}_{RMS}$ , $\cos(\varphi) = 0.8$ , $f_{AC\ sine} = 50\text{ Hz}$ , $f_{sw} = 5000\text{ Hz}$ , $T_{inlet} = 40^{\circ}\text{C}$ , $T_j \leq 125^{\circ}\text{C}$	$P_{loss}$		1975		W

### Notes

Maximum junction temperature limited to  $125^{\circ}\text{C}$  under all operating conditions

prepared by: OW	date of publication: 2013-10-18
approved by: AR	revision: 2.2