

Title Rexroth SYNAX 200
Version 11

Type of Documentation Version Notes

Document Typecode DOK-SYNAX*-SY*-11VRS**-FV01-EN-P

Internal File Reference

- Box 40-11V-EN
- SY111E_V.doc
- Document number 120-2200-B341-01/EN

Purpose of Documentation The documentation gives an overview about the new and changed functionalities of SYNAX 200 version 11 compared with the previous version 10.

Record of Revisions

Description	Release Date	Notes
DOK-SYNAX*-SY*-11VRS**-FV01-EN-P	11.03	Version 11VRS

Copyright © 2003 Bosch Rexroth AG

Copying this document, giving it to others and the use or communication of the contents thereof without express authority, are forbidden. Offenders are liable for the payment of damages. All rights are reserved in the event of the grant of a patent or the registration of a utility model or design (DIN 34-1).

Validity The specified data is for product description purposes only and may not be deemed to be guaranteed unless expressly confirmed in the contract. All rights are reserved with respect to the content of this documentation and the availability of the product.

Published by Bosch Rexroth AG
Bgm.-Dr.-Nebel-Str. 2 • D-97816 Lohr a. Main
Telephone +49 (0)93 52/40-0 • Tx 68 94 21 • Fax +49 (0)93 52/40-48 85
<http://www.boschrexroth.com/>
Dept. BRC/ESP (TI)

Note This document has been printed on chlorine-free bleached paper.

Summary of Documentation - Overview

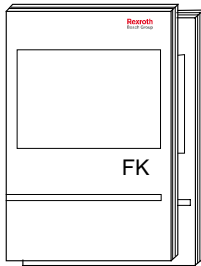

Functional Description: Interfaces:

Help familiarize the user with SYNAX 200 and the functions of SYNAX 200

Order designation:
 DOK-SYNAX*-SY*-11V*1/2-FK01-EN-P
 DOK-SYNAX*-SY*-11V*2/2-FK01-EN-P

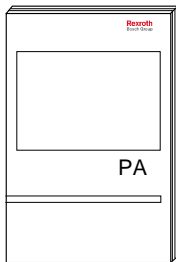

Parameter Description:

Description of the SYNAX 200 system parameters

Order designation:
 DOK-SYNAX*-SY*-11VRS**-PA01-EN-P

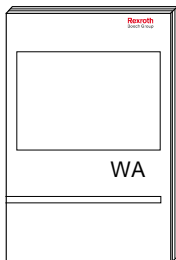

Trouble Shooting Guide:

Explanation of the diagnostics states
 How to proceed when eliminating faults

Order designation:
 DOK-SYNAX*-SY*-11VRS**-WA01-EN-P

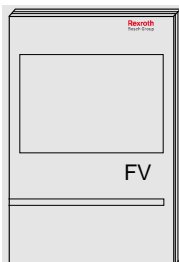

Firmware Version Notes:

Description of the new and changed functions between SYNAX 200 version 11 and previous version 10

Order designation:
 DOK-SYNAX*-SY*-11VRS**-FV01-EN-P

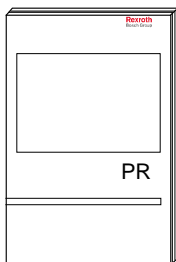

Project Planning:

Selection of units and hardware components
 Basic control in cabinet construction

Order designation:
 DOK-SYNAX*-SY*-11VRS**-PR01-EN-P

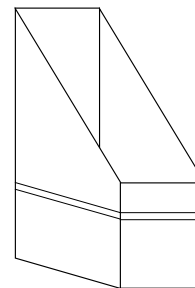

Order designation:
 DOK-SYNAX*-SY*-11VRS**-4001-EN-P

Contents

1	References	1-1
1.1	Product family	1-1
1.2	Referenced hardware	1-1
1.3	Reference list firmware/software	1-3
	Motion control firmware	1-3
	Drive firmware.....	1-4
	Commissioning interface / PLC programming interface.....	1-5
	Firmware download	1-5
	Cam tool	1-6
	HMI software.....	1-6
	Miniature control terminals of VCP series	1-6
	Miniature control terminals of BTV series.....	1-7
1.4	System documentation	1-8
	Motion control components	1-8
	Drive components.....	1-8
	Visualization units.....	1-9
	Miniature control terminals VCP.....	1-9
	Miniature control terminals BTV	1-9
2	SYNAX 200 firmware version 11VRS	2-1
2.1	Release notes on SYNAX 200 firmware version 11V02	2-1
2.2	Flash module labellings	2-1
2.3	New functions	2-2
	Support of new hardware	2-2
	Real time clock	2-3
	Winding controller with load cell	2-3
	IndraLogic: integrated PLC on the PPC	2-4
	PPC-R2x: Ethernet on board.....	2-4
	IndraDrive: integrated safety technology in the drive	2-5
	IndraDrive: freely configurable status/control bits	2-5
	IndraDrive: dynamic cam shaft distance and gear switch	2-6
	IndraDrive parameters.....	2-6
2.4	New parameters, I/Os and diagnoses	2-7
	New Y parameters.....	2-7
	New C parameters.....	2-7
	New A parameters	2-8
	New inputs/outputs	2-9
	New diagnostic messages.....	2-10

2.5	Changed and extended functions.....	2-11
	Process controller cycle times.....	2-11
	Import of process controller actual values via fieldbus.....	2-11
	Register controller.....	2-11
	Cyclic processing of analog inputs.....	2-11
	Following axis: gear functions.....	2-12
	IndraDrive: Gear change without phase switching.....	2-13
	IndraDrive: 4 cam tables.....	2-13
	IndraDrive: analog channel.....	2-14
	IndraDrive: status messages.....	2-14
	IndraDrive: extended oscilloscope function.....	2-15
	IndraDrive: SYNAX diagnosis at drive errors.....	2-15
	3964R interface.....	2-16
	ARCNET interface.....	2-16
	Attribute list for drive parameters.....	2-17
	I/O logic.....	2-17
2.6	Changed and extended parameters, I/Os and diagnoses.....	2-18
	Changed Y parameters.....	2-18
	Changed C parameters.....	2-19
	Changed A parameters.....	2-20
	Changed inputs/outputs.....	2-21
	Changed diagnostic messages.....	2-21
2.7	Phase out of functions / hardware.....	2-22

3 Attachment: abstract of the functional description 3-1

3.1	Process controller cycle times.....	3-1
	Cyclic distribution.....	3-1
	Functional distribution.....	3-2
3.2	Process controller actual values.....	3-4
3.3	Processing analog input values.....	3-4
3.4	I/O logic.....	3-5
	Freely configurable inputs/outputs for IndraDrive.....	3-5
	Addressing of the integrated inputs/outputs (IndraDrive).....	3-5
3.5	Integrated safety technology in IndraDrive.....	3-7

4 Service & Support 4-1

4.1	Helpdesk.....	4-1
4.2	Service-Hotline.....	4-1
4.3	Internet.....	4-1
4.4	Vor der Kontaktaufnahme... - Before contacting us... ..	4-1
4.5	Kundenbetreuungsstellen - Sales & Service Facilities.....	4-2

1 References

1.1 Product family

The firmware version description references the product family:
SYNAX 200 Decentralized System for the Synchronization of Machine Axes.

Current firmware versions: FWA-PPCR0*-SY*-11VRS-D0,
 FWA-PPCR0*-SL*-11VRS-D0,
 FWA-PPCPR*-SY*-11VRS-D0,
 FWA-PPCPR*-SL*-11VRS-D0.

1.2 Referenced hardware

Permissible module carrier

- RMB02.2-02 (for installation of 2 modules)
- RMB02.2-04 (for installation of 4 modules)

Permissible controls

- PPC-R01.2 (small, 1 RECO slot, up to 1 expansion card)
- PPC-R02.2 (wide, 2 RECO slots, up to 3 expansion cards)
- PPC-R21.1N-N (small, 1 RECO slot, up to 1 expansion card)
- PPC-R21.1N-T
(small, 1 RECO slot, Ethernet on board, up to 1 expansion card)
- PPC-R22.1N-N (wide, 2 RECO slots, up to 3 expansion cards)
- PPC-R22.1N-T
(wide, 2 RECO slots, Ethernet on board, up to 3 expansion cards)
- PPC-P11.1N-N (PCI plug-in card, up to 3 expansion cards)

Fieldbus slave interfaces PPC-Rxx and PPC-P11

- DAQ03 (cross link and/or ARCNET)
- DPS01 (Profibus slave)
- IBS03 (Interbus slave)
- DNS03 (DeviceNet slave)
- CNS01 (ControlNet slave)

Fieldbus slave interfaces for PPC-R0x and PPC-P11

- ETH01 (Ethernet/IP, Ethernet)

Fieldbus master interfaces for integrated PLC

- DPM01 (Profibus master)
- DNM03 (DeviceNet master)

RECO local bus, I/O modules

- RME02.2-16-DC024 (digital inputs)
- RME02.2-32-DC024 (digital inputs)
- RME02.2-16-AC115 (digital inputs)
- RMA02.2-16-DC024-200 (digital outputs)
- RMA02.2-32-DC024-050 (digital outputs)
- RMA02.2-16-AC230-200 (digital outputs)
- RMA02.2-16-RE230-200 (digital outputs)

RECO local bus, module for integrated PLC

- RMC02.2-2E-1A (analog module 2 x input, 1 x output)

RECO Inline, fieldbus modules for the integrated PLC (slave interfaces)

- R-IBS IL 24 BK-T/U (INTERBUS-S bus clamp)
- R-IBS IL 24 BK-DSUB (INTERBUS-S bus clamp)
- R-IBS IL 24 RB-T (INTERBUS-S remote bus branch)
- R-IL PB BK (PROFIBUS-DP bus clamp)
- R-IB IL 24 DI 2 (clamp with 2 digital inputs)
- R-IB IL 24 DI 4 (clamp with 4 digital inputs)
- R-IB IL 24 DI 8 (clamp with 8 digital inputs)
- R-IB IL 24 DI 16 (clamp with 16 digital inputs)
- R-IB IL 24 EDI 2-DES (clamp with 2 digital and 2 diagnostic inputs)
- R-IB IL 24 DO 2-2A (clamp with 2 digital outputs 2A)
- R-IB IL 24 DO 4 (clamp with 4 digital outputs 500 mA)
- R-IB IL 24 DO 8 (clamp with 4 digital outputs 500 mA)
- R-IB IL 24 DO 8-2A (clamp with 8 digital outputs 2A)
- R-IB IL 24 DO 16 (clamp with 16 digital outputs 500 mA)
- R-IB IL 24/230 DOR 1/W (clamp with relay output)
- R-IB IL 24/230 DOR 4/W (clamp with 4 relay outputs)
- R-IB IL DOR LV-SET (terminal set as accessories of the relay clamp)
- R-IB IL 24 AI 2/SF (clamp with 2 analog input channels)
- R-IB IL 24 TEMP 2 RTD (clamp with 2 input channels for connection of temperature resistor)
- R-IB IL 24 AO 1/SF (clamp with analog output channel)
- R-IB IL 24 AO 2 U/BP (clamp with 2 analog voltage outputs)
- R-IB IL 24 CNT (function clamp counter – timer)
- R-IB IL PWR IN (supply clamp)
- R-IB IL SEG/F (segment clamp)

Drive families

- Diax 03
- Diax 04
- IndraDrive
- EcoDrive 03
- EcoDrive Cs

1.3 Reference list firmware/software

Note: The software with suffix -COPY may be copied.

Motion control firmware

SYNAX 200 MotionControl PPC-R0x without PLC

Product:	Product firmware (order designation):	Printed board firmware (flash module labelling):
PPC-R0x	FWA-PPCR0*-SY*-11VRS-D0-XXXXXX	FWB-PSM01*-SY*-11VRS-D0
PPC-R0x + Profibus slave	FWA-PPCR0*-SY*-11VRS-D0-P2XXXX	FWB-PSM01*-SY*-11VRS-D0 FWC-DPS01*-PHP-02VRS-NN
PPC-R0x + Interbus slave	FWA-PPCR0*-SY*-11VRS-D0-B2XXXX	FWB-PSM01*-SY*-11VRS-D0 FWC-IBS03*-PHB-01VRS-NN
PPC-R0x + DeviceNet slave	FWA-PPCR0*-SY*-11VRS-D0-V2XXXX	FWB-PSM01*-SY*-11VRS-D0 FWC-DNS01*-PHV-01VRS-NN
PPC-R0x + Ethernet/IP slave or Ethernet	FWA-PPCR0*-SY*-11VRS-D0-T2XXXX	FWB-PSM01*-SY*-11VRS-D0 FWC-ETH01*-PHT-02VRS-NN
PPC-R0x + ControlNet slave	FWA-PPCR0*-SY*-11VRS-D0-L2XXXX	FWB-PSM01*-SY*-11VRS-D0 FWC-CNS01*-PHL-01VRS-NN
PPC-R0x + Profibus slave + Ethernet (HMI)	FWA-PPCR0*-SY*-11VRS-D0-P2T2XX	FWB-PSM01*-SY*-11VRS-D0 FWC-DPS01*-PHP-02VRS-NN FWC-ETH01*-PHT-02VRS-NN
PPC-R0x + DeviceNet slave + Ethernet (HMI)	FWA-PPCR0*-SY*-11VRS-D0-V2T2XX	FWB-PSM01*-SY*-11VRS-D0 FWC-DNS01*-PHV-01VRS-NN FWC-ETH01*-PHT-02VRS-NN

Fig. 1-1: SYNAX 200 MotionControl PPC-R0x without PLC

SYNAX 200 MotionControl PPC-R2x or PPC-P without PLC

Product:	Product firmware (order designation):	Printed board firmware (flash module labelling):
PPC-R2x or PPC-P	FWA-PPCPR*-SY*-11VRS-D0-XXXXXX	FWC-PFM01*-SY*-11VRS-D0
PPC-R2x or PPC-P + Profibus slave	FWA-PPCPR*-SY*-11VRS-D0-P2XXXX	FWC-PFM01*-SY*-11VRS-D0 FWC-DPS01*-PHP-02VRS-NN
PPC-R2x or PPC-P + DeviceNet slave	FWA-PPCPR*-SY*-11VRS-D0-V2XXXX	FWC-PFM01*-SY*-11VRS-D0 FWC-DNS01*-PHV-01VRS-NN

Fig. 1-2: SYNAX 200 MotionControl PPC-R2x or PPC-P without PLC

SYNAX 200 MotionControl PPC-R0x with PLC

Product:	Product firmware (order designation):	Printed board firmware (flash module labelling):
PPC-R0x	FWA-PPCR0*-SL*-11VRS-D0-XXXXXX	FWB-PSM02*-SL*-11VRS-D0
PPC-R0x + Profibus slave	FWA-PPCR0*-SL*-11VRS-D0-P2XXXX	FWB-PSM02*-SL*-11VRS-D0 FWC-DPS01*-PHP-02VRS-NN
PPC-R0x + DeviceNet slave	FWA-PPCR0*-SL*-11VRS-D0-V2XXXX	FWB-PSM02*-SL*-11VRS-D0 FWC-DNS01*-PHV-01VRS-NN
PPC-R0x + Profibus master	FWA-PPCR0*-SL*-11VRS-D0-P1XXXX	FWB-PSM02*-SL*-11VRS-D0 FWC-DPM01*-PHP-02VRS-NN
PPC-R0x + DeviceNet master	FWA-PPCR0*-SL*-11VRS-D0-V1XXXX	FWB-PSM02*-SL*-11VRS-D0 FWC-DNM03*-PHV-01VRS-NN

Fig. 1-3: SYNAX 200 MotionControl PPC-R0x with PLC

SYNAX 200 MotionControl PPC-R2x and PPC-P with PLC

Product:	Product firmware (order designation):	Printed board firmware (flash module labelling):
PPC-R2x or PPC-P	FWA-PPCPR*-SL*-11VRS-D0-XXXXXX	FWC-PFM01*-SL*-11VRS-D0
PPC-R2x or PPC-P + Profibus slave	FWA-PPCPR*-SL*-11VRS-D0-P2XXXX	FWC-PFM01*-SL*-11VRS-D0 FWC-DPS01*-PHP-02VRS-NN
PPC-R2x or PPC-P + DeviceNet slave	FWA-PPCPR*-SL*-11VRS-D0-V2XXXX	FWC-PFM01*-SL*-11VRS-D0 FWC-DNS01*-PHV-01VRS-NN
PPC-R2x or PPC-P + Profibus master	FWA-PPCPR*-SL*-11VRS-D0-P1XXXX	FWC-PFM01*-SL*-11VRS-D0 FWC-DPM01*-PHP-02VRS-NN
PPC-R2x or PPC-P + DeviceNet master	FWA-PPCPR*-SL*-11VRS-D0-V1XXXX	FWC-PFM01*-SL*-11VRS-D0 FWC-DNM03*-PHV-01VRS-NN

Fig. 1-4: SYNAX 200 MotionControl PPC-R0x with PLC

Drive firmware

Full versions: firmware for synchronous axis with all auxiliary modes

Product:	Product firmware (order designation):	Printed board firmware (EPROM/flash module labelling):
Drive family DiAx 03	FWA-DIAX03-ELS-06VRS-MS	FWC-DSM2.3-ELS-06VRS-MS
Drive family DiAx 04	FWA-DIAX04-ELS-06VRS-MS	FWC-HSM1.1-ELS-06VRS-MS
Drive family EcoDrive03	FWA-DRIVE*-SGP-20VRS-MS	FWC-ESM2.2-SGP-20VRS-MS
Drive family IndraDrive	FWA-INDRV*-MPH-02VRS-MS-1-SNC-NN	FWC-CSH1.1-MPH-02VRS-MS FWC-HSI11*-SST-01VRS-MS
Drive family IndraDrive + all packages	FWA-INDRV*-MPH-02VRS-MS-1-ALL-NN	FWC-CSH1.1-MPH-02VRS-MS FWC-HSI11*-SST-01VRS-MS
Drive family IndraDrive + SPS	FWA-INDRV*-MPH-02VRS-MS-1-SNC-ML	FWC-CSH1.1-MPH-02VRS-MS FWC-HSI11*-SST-01VRS-MS
Drive family IndraDrive + all packages + PLC	FWA-INDRV*-MPH-02VRS-MS-1-ALL-ML	FWC-CSH1.1-MPH-02VRS-MS FWC-HSI11*-SST-01VRS-MS

Fig. 1-5: Drive firmware (synchronization mode, positioning mode, idle mode)

Firmware for positioning mode and idle mode

Product:	Product firmware (order designation):	Printed board firmware (EPROM/flash module labelling):
Drive family Diax	FWA-DIAX03-SSE-03VRS-MS FWA-DIAX04-SSE-03VRS-MS	FWC-DSM2.3-SSE-03VRS-MS FWC-HSM1.1-SSE-03VRS-MS
Drive family EcoDrive 03	FWA-ECODR3-SMT-02VRS-MS	FWC-ESM2.1-SMT-02VRS-MS
Drive family EcoDrive Cs		FWC-ECODR3-MGP-01VRS-MS
Drive family IndraDrive	FWA-INDRV*-MPH-02VRS-MS-1-NNN-NN	FWC-CSH1.1-MPH-02VRS-MS FWC-HSI11*-SST-01VRS-MS
Drive family IndraDrive + PLC	FWA-INDRV*-MPH-02VRS-MS-1-NNN-ML	FWC-CSH1.1-MPH-02VRS-MS FWC-HSI11*-SST-01VRS-MS

Fig. 1-6: Drive firmware (positioning and idle mode)

Firmware for speed-controlled axes (idle mode)

Product:	Product firmware (order designation):	Printed board firmware (EPROM/flash module labelling):
Drive family IndraDrive	FWA-INDRV*-MPH-02VRS-MS-0-NNN-NN	FWC-CSH1.1-MPH-02VRS-MS FWC-HSI11*-SST-01VRS-MS
Drive family IndraDrive + PLC	FWA-INDRV*-MPH-02VRS-MS-0-NNN-ML	FWC-CSH1.1-MPH-02VRS-MS FWC-HSI11*-SST-01VRS-MS

Fig. 1-7: Drive firmware (idle mode)

Commissioning interface / PLC programming interface

Product:	Product software (order designation):	CD labelling
Parameterization and PLC programming interface SynTop and IndraLogic	SWA-SYNAX*-INB-11VRS-D0-CD650-COPY	SWD-SYNAX*-INB-11VRS-D0-CD650

Fig. 1-8: Commissioning software

Firmware download

Product:	Product software (order designation):	Disk labelling
DOLFI tool for download of firmware	SWA-DOL*PC-INB-01VRS-MS-C1,44-COPY	SWD-DOL*PC-INB-01VRS-MS-C1,44

Fig. 1-9: Firmware download

Note: DOLFI can be found on the CD SWA-SYNAX*-INB-11VRS-D0-CD650-COPY.

Cam tool

Product:	Product software (order designation):	CD labelling
CamBuilder	SWA-CAM*PC-INB-01VRS-D0-CD650	SWD-CAM*PC-INB-01VRS-D0-CD650

Fig. 1-10: Cam tool

HMI software

Product:	Product software (order designation):	Product software (CD labelling):
HMI for SYNAX200	SWA-SYNAX*-HMI-11VRS-D0-CD650	SWD-SYNAX*-HMI-11VRS-D0-CD650
License for WinStudio programming interface	SWS-WIS*PC-ENL-01VRS-EN-64000	Max. 64000 variables, target system WinNT/2000/XP/CE
License for WinStudio-programming interface	SWS-WIS*PC-ENL-01VRS-EN-1500	Max. 1500 variables, target system WinNT/2000/XP/CE
Runtime license for WinStudio-HMI	SWS-WIS*PC-RUL-01VRS-EN-64000	Max. 64000 variables, target system WinNT/2000/XP
Runtime license for WinStudio-HMI	SWS-WIS*PC-RUL-01VRS-EN-1500	Max. 1500 variables, target system WinNT/2000/XP

Fig. 1-11: HMI software

Miniature control terminals of VCP series

Product:	Product software/firmware (order designation):	Disk labelling/ printed board firmware (EPROM/flash module labelling)
VI-Composer – VCP project planning software	SWA-VIC*PC-INB-01VRS-D0-CD650	SWD-VIC*PC-INB-01VRS-D0-CD650
VCP firmware (Runtime):		
VCP 02	FWA-VCP02*-SUE-01VRS-EN	FWC-VCP02*-SUE-01VRS-EN
VCP 05	FWA-VCP05*-SUE-01VRS-EN	FWC-VCP05*-SUE-01VRS-EN
VCP 08	FWA-VCP08*-SUE-01VRS-EN	FWC-VCP08*-SUE-01VRS-EN
VCP 20	FWA-VCP20*-SUE-01VRS-EN	FWC-VCP20*-SUE-01VRS-EN
VCP 25	FWA-VCP25*-SUE-01VRS-EN	FWC-VCP25*-SUE-01VRS-EN

Fig. 1-12: Miniature control terminals VCP

Miniature control terminals of BTV series

Product:	Product software/firmware (order designation):	Disk labelling/ printed board firmware (EPROM/flash module labelling)
Programming interface Screenmanager	SWA-SCM*PC-INB-05VRS-MS-CD650	SWD-SCM*PC-INB-05VRS-MS-CD650
BTV firmware (Runtime):		
BTV 04	SWA-BTV04*-SCM-05VRS-MS-C1,44	SWD-BTV04*-SCM-05VRS-MS-C1,44
BTV 05	SWA-BTV05*-SCM-05VRS-MS-C1,44	SWD-BTV05*-SCM-05VRS-MS-C1,44
BTV 06	SWA-BTV06*-SCM-05VRS-MS-C1,44	SWD-BTV06*-SCM-05VRS-MS-C1,44
BTC 06	SWA-BTC06*-SCM-05VRS-MS-C1,44	SWD-BTC06*-SCM-05VRS-MS-C1,44
BTV-Firmware (Loader):		
BTV 04	FWA-BTV04*-DOL-01VRS-EN	FWC-BTV04*-DOL-01VRS-EN
BTV 05	FWA-BTV05*-DOL-01VRS-EN	FWC-BTV05*-DOL-01VRS-EN
BTV 06	FWA-BTV06*-DOL-01VRS-EN	FWC-BTV06*-DOL-01VRS-EN
BTC 06	FWA-BTC06*-DOL-01VRS-EN	FWC-BTC06*-DOL-01VRS-EN

Fig. 1-13: Miniature control terminals BTV

1.4 System documentation

Additional information of the components described can be found in the following documentations.

Motion control components

Order designation	Title
DOK-SYNAX*-SY*-11V*1/2-FK01-EN-P	Rexroth SYNAX 200 - Functional Description
DOK-SYNAX*-SY*-11V*2/2-FK01-EN-P	Rexroth SYNAX 200 - Interfaces Description
DOK-SYNAX*-SY*-11VRS**-PA01-EN-P	Rexroth SYNAX 200 - Parameter Description
DOK-SYNAX*-SY*-11VRS**-PR01-EN-P	Rexroth SYNAX 200 - Project Planning Manual
DOK-SYNAX*-SY*-11VRS**-WA01-EN-P	Rexroth SYNAX 200 - Troubleshooting Guide
DOK-SYNAX*-SY*-11VRS**-FV01-EN-P	Rexroth SYNAX 200 - Version Notes
DOK-SYNAX*-SY*-11VRS**-4001-EN-P	Rexroth SYNAX 200 - Box 40-11V
SWA-SYNAX*-INB-11VRS-D0-CD650-COPY	General help for Rexroth SYNAX 200 - version 11VRS
DOK-CONTRL-PPC-R0*.2**-PR03-EN-P	PPC-R0*.2 - Project Planning Manual
DOK-CONTRL-RECO02.2***-PR01-EN-P	SERCOS I/O Unit RECO02.2 - Configuration
DOK-CONTRL-R-IL*INLINE-KB02-EN-P	RECO-Inline Brief Description
DOK-CONTRL-RF-FLS-IB**-PR01-EN-P	Rexroth RECO Fieldline INTERBUS Device - Project Planning Manual
DOK-CONTRL-RF-FLS-PB**-PR01-EN-P	Rexroth RECO Fieldline PROFIBUS Device - Project Planning Manual

Fig. 1-14: Documentation: motion control components

Drive components

Order designation	Title
DOK-DIAX03-DKR*****-PR02-EN-P	DKR02, DKR03 and DKR04 Drive controllers - Project Planning Manual
DOK-DIAX03-DKR05.2****-PR02-EN-P	DKR05.2 Drive controller - Project Planning Manual
DOK-DIAX03-ELS-06VRS**-IF01-EN-P	DiAx 03 - Brief Description
DOK-DIAX04-HDD+HDS**G2-PR05-EN-P	DiAx 04 HDD and HDS Controllers 2 nd Generation - Project Planning Manual
DOK-DIAX04-PLUG*IN*MOD-PR03-EN-P	DiAx 04 Plug-in Modules for Digital Intelligent Drive Controllers - Project Planning Manual
DOK-DIAX04-ELS-06VRS**-6001-EN-P	DiAx 04 - Box 60-06V
DOK-POWER*-HVE+HVR**G2-AW07-EN-P	DiAx 04 HVE and HVR 2 nd Generation Power Supply Units - Application Description
DOK-INDRV*-HMS+HMD****-PR01-EN-P	Rexroth IndraDrive M - Drive controllers - Power section - Project Planning Manual
DOK-INDRV*-CSH*****-PR01-EN-P	Rexroth IndraDrive - Drive controllers - Control section - Project Planning Manual
DOK-INDRV*-MP*-02VRS**-8101-EN-P	Rexroth IndraDrive - Box 81-02V
DOK-ECODR3-DKC**.3****-PR05-EN-P	EcoDrive 03 -Project Planning Manual
DOK-ECODR3-DKC**.3CS*-PR01-EN-P	Rexroth EcoDrive Cs - Project Planning Manual
DOK-DRIVE*-SGP-20VRS**-7201-EN-P	Rexroth EcoDrive 03 - Box 72-01V
DOK-GENERL-DRIVEHELP**-GN07-MS-D0600	Drive help
DOK-GENERL-EMV*****-PR02-EN-P	Electromagnetic Compatibility (EMC) in Drive and Control Systems – Project Planning Manual

Fig. 1-15: Documentation: Drive components

Visualization units

Order designation	Title
DOK-SUPPL*-BTV16/40***-PR02-DE-P	Rexroth BTV 16 and Rexroth BTV 40 - Project Planning Manual

Fig. 1-16: Documentation: visualization units

Miniature control terminals VCP

Order designation	Title
DOK-SUPPL*-VCP02*****-PR01-EN-P	Rexroth VCP 02 - Project Planning Manual
DOK-SUPPL*-VCP05*****-PR01-EN-P	Rexroth VCP 05 - Project Planning Manual
DOK-SUPPL*-VCP08*****-PR01-EN-P	Rexroth VCP 08 - Project Planning Manual
DOK-SUPPL*-VCP20*****-PR01-EN-P	Rexroth VCP 20 - Project Planning Manual
DOK-SUPPL*-VCP25*****-PR01-EN-P	Rexroth VCP 25 - Project Planning Manual
DOK-CONTRL-VIC*PRO*V01-AW01-EN-P	VI-Composer 01VRS - Functional Description

Fig. 1-17: Documentation: miniature control terminals VCP

Miniature control terminals BTV

Order designation	Title
DOK-SUPPL*-BTV04.2****-FK02-EN-P	System 200 BTV 04.2 - Description of Functions
DOK-SUPPL*-BTV05.2****-FK03-EN-P	System 200 BTV 05.2 - Functional Description
DOK-SUPPL*-BTV06.1****-PR02-EN-P	System 200 BTV 06.1 - Project Planning Manual
DOK-SUPPL*-BTC06*****-PR03-EN-P	System 200 BTC 06 - Project Planning Manual
DOK-SUPPL*-SCM*BEDIEN*-AW04-EN-P	SCREENMANAGER for Small HMIs - Application Description
DOK-SUPPL*-SCM*PROG*V5-AW02-EN-P	SCREENMANAGER 05VRS - Functional Description

Fig. 1-18: Documentation: Miniature control terminals BTV

2 SYNAX 200 firmware version 11VRS

2.1 Release notes on SYNAX 200 firmware version 11V02

The SYNAX 200 firmware version 11V02 was released
October 15th 2003.

2.2 Flash module labellings

Module	Labelling	Firmware
Flash module PSM01.1	<p>PSM01.1-FW 280669 Kxx/yy SN280669-xxxxx xxx FWB-PSM01*-SY*-11V02-D0 298502 Kxx/yy</p>	<p>FWC-PSM01*-SY*-11V02 for PPC-R0x Motion only</p>
Flash module PFM01.1	<p>PFM01.1-016-FW 295174 Kxx/yy SN295174-xxxxx xxx FWC-PFM01*-SY*-11V02-D0 Kxx/yy</p>	<p>FWC-PFM01*-SY*-11V02 for PPC-R2x and PPC-P11 Motion only</p>
Flash module PSM02.1	<p>PSM02.1-128-08-FW 292254 Kxx/yy SN292254-xxxxx xxx FWB-PSM02*-SL*-11V02-D0 298505 Kxx/yy</p>	<p>FWC-PSM01*-SL*-11V02 for PPC-R0x Motion + IndraLogic</p>
Flash module PFM01.1	<p>PFM01.1-016-FW 295174 Kxx/yy SN295174-xxxxx xxx FWC-PFM01*-SL*-11V02-D0 Kxx/yy</p>	<p>FWC-PFM01*-SL*-11V02 for PPC-R2x and PPC-P11 Motion + IndraLogic</p>

Fig. 2-1: Flash module labelling for version 11V02

2.3 New functions

Support of new hardware

SYNAX 200 Version 11VRS supports the following new hardware components:

PPC-R2x

The PPC-R2x is a redesigned version of the PPC-R with the following highlights:

- increased flash memory (16 MB),
- increased RAM memory (32 MB),
- higher processor clock (240 MHz),
- optional: Ethernet onboard.

Drive family IndraDrive

Drives of the new drive family IndraDrive are supported as of drive firmware 02VRS.

New functions:

- Safety technology,
- Drive integrated PLC "IndraLogic",
- Digital inputs/outputs on board,
- Scalable functionality (firmware functional packages).

Fig. 2-2 exemplifies typical functional options for SYNAX applications.

IndraDrive firmware	Functional option
FWA-INDRV*-MPH-02VRS-MS-1-SNC-NN	Basic option (Closed Loop) + synchronization -> synchronous axes
FWA-INDRV*-MPH-02VRS-MS-1-SNC-ML	Basic option (Closed Loop) + synchronization + IndraLogic -> synchronous axes with PLC/technology functionality
FWA-INDRV*-MPH-02VRS-MS-1-NNN-NN	Basic option (Closed Loop) -> e.g., positioning axes

Fig. 2-2: Firmware function options for IndraDrive (examples)

ECODRIVE Cs

The EcoDrive Cs is a small compact variant of the EcoDrive line. SYNAX 200 version 11VRS supports it in operation modes

- positioning,
- idle.

Real time clock

A real time clock was implemented on the hardware platforms PPC-Rnn.

Hardware version	Features
PPC-R0x	Optional function, additional battery necessary
PPC-R2x	Function onboard, buffering up to 5 days

Fig. 2-3: Real time clock of the PPC-R

Winding controller with load cell

The SYNAX process controllers were extended by the "Winding controller with load cell" function.

Features:

- PI controller with effect on the torque of the winding axis
- Taper tension (linear / hyperbolic)
- Diameter calculation
- Acceleration compensation with respect of the load inertia
- Friction compensation with parametric profile points
- Diameter specific speed adjustment via fine adjust
- Tensioning via speed offset

Configuration options

In the "Process control - control word 2" (A-0-0146) using the bits 4, 9, 13 and 14 the different combinations of the winding controller with load cell can be parameterized.

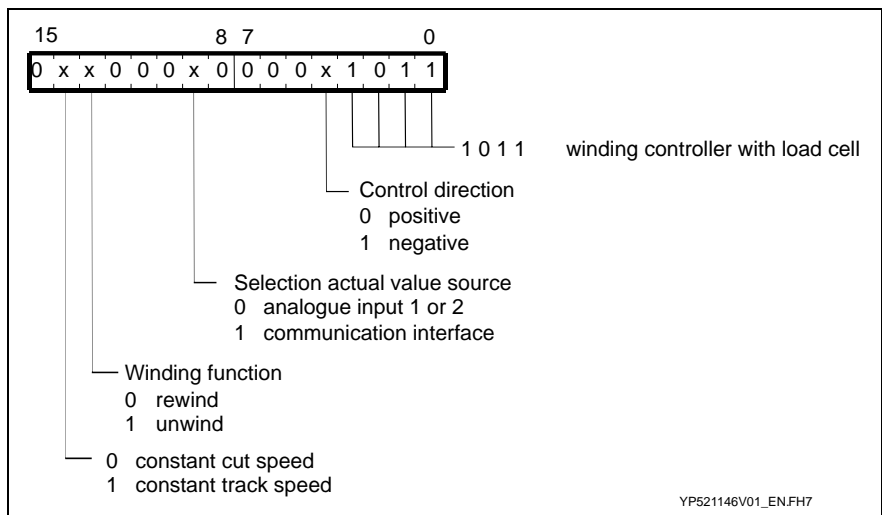

Fig. 2-4: Bits of winding controller with load cell

IndraLogic: integrated PLC on the PPC

Programming interface IndraLogic 1.0

The integrated PLC as of SYNAX 200 version 11VRS is programmed with the programming interface IndraLogic 1.0.

IndraLogic is a development tool for PLC programming. IndraLogic gives the PLC programmer a simple entry into the programming languages of the IEC 61131-3.

Supported programming languages

IndraLogic supports all in the norm IEC-61131 described programming languages:

- | | |
|----------------------------|--|
| textual languages | <ul style="list-style-type: none">• Instruction list (IL)• Structured text (ST) |
| graphical languages | <ul style="list-style-type: none">• Sequential function chart (SFC)• Continuous function chart (CFC)• Ladder diagram (LD)• Function block diagram (FBD) |

Multitasking

IndraLogic supports preemptive multitasking with up to 16 IEC tasks.

The following task types are supported:

- Cyclic (time triggered)
- Freewheeling
- Event triggered
- External event triggered

In SYNAX 200 version 11VRS one external event triggered task is available. The task "OP_MODE_SERCOS_CYCLIC" will be called synchronized to the SERCOS cycle during the operation mode.

Libraries/function blocks

The SYNAX specific libraries known by SYNAX with WinPCL are also available in IndraLogic.

New acyclic communication function blocks are the function blocks MSV_xxx. These function blocks have direct access to all control parameters. Reading/writing these parameters is done immediately at the activation of the function block and does not take several PLC cycles. Cyclic reading with these function blocks is possible.

PPC-R2x: Ethernet on board

The motion control hardware PPC-R2x is available with an integrated Ethernet connection. The protocols are downwards compatible to version 08VRS.

New functions:

- Transmission rate adjustable to 100-MBaud or 10-MBaud
- Auto negotiation (Ethernet participant according to IEEE802.3): automatic setting of the transmission rate and duplex operation

IndraDrive: integrated safety technology in the drive

The control sections of the IndraDrive drive range can be equipped with a "Starting lockout" optional module or a "Safety technology I/O" optional module. In this way, IndraDrive is equipped with integrated safety technology, which provides the user with a electronic starting lock-out or an universally programmable monitor for safety related motion/stopping process.

"Integrated safety technology" refers to application-related safety functions that are applicable for personal protection on machines in accordance with EN 954-1 category 3.

The "Starting lockout" optional module provides the following application-related safety function:

- Safety related starting lock-out (stop category 0 according to EN 60204-1)

The "Safety technology I/O" provides, e.g., the following application-related safety functions:

- Safety related standstill (stop category 1 according to EN 60204-1).
- Safety related operational stop (stop category 2 according to EN 60204-1).
- Safety related drive interlock (stop category 1 according to EN 60204-1).
- Safely monitored stopping (for functions "Safety related standstill", "Safety related operational stop", "Safety related drive interlock")
- Safety related reduced speed
- ...

The safety technology has been tested and certified by an EU prototype test of the SIBE Switzerland certification authority.

(also see "Integrated safety technology in IndraDrive" page 3-7)

IndraDrive: freely configurable status/control bits

Each IndraDrive device supports a "freely configurable signal status/control word" (S-0-0144/S-0-0145) for the control and diagnosis of real time functions via the SERCOS channel.

Up to four of the 16 new status/control bits can be freely configured. They can be allocated to drive parameters or signals with the parameters "Configuration/Assign list signal status/control word" (A-0-0051... A-0-0054).

(see "Freely configurable inputs/outputs for IndraDrive" page 3-5).

IndraDrive: dynamic cam shaft distance and gear switch

For applications with electronic cam the IndraDrive offers the functionality "Dynamic cam shaft distance and gear switch". This function enables a change of the profile of motion on the fly. The switching can be triggered by two events.

The trigger is selected with input "Selection of trigger for cam shaft and gear switch" (`_E:F#.32`) on motion control side:

<code>_E:F#.32</code>	Trigger	Function
0	Reaching the cam shaft switch angle	The cam shaft distance and/or the electronic gear are switched at the same time.
1	Switching the cam table at cam switch angle	- The electronic gear or - the electronic gear with cam shaft distance is switched optional. To determine the parameters to switch two bits are provided in "Control word for synchronous operation modes" (P-0-0088): Bit 3: cam shaft distance switch Bit 4: gear switch

Fig. 2-5: Dynamic cam shaft distance/gear switch

The input `_E:F#.32` is transmitted to the drive in the "Freely configurable signal control word" (S-0-0145) and influences directly bit 6 in the "Control word for synchronous operation modes" (P-0-0088).

IndraDrive parameters

With IndraDrive only the parameters are visible that are required for the installed functions. These are activated function options or optional hardware modules.

The parameters of the non-installed or non-activated functions are 'hidden' and are not considered at parameter backups.

Example:

- Synchronization modes and their parameters can only be used with the functional option "SNC". If the drive type (A-0-0095) "IndraDrive MPx-1-SNC-xx" is displayed, so this option is installed and activated.
- Parameters of the safety technology (see documentation DOK-INDRV*-GEN-**VRS**-PA01-EN-P) are only present, if the hardware for the safety technology is mounted. These parameters can be written if the safety technology is deactivated or when the safety password (P-0-3206) is disabled. If the safety password is set, all parameters are write protected.
- Parameters to use binary inputs/outputs of a HEA01 module (P-0-0081, P-0-0082, P-0-0681, P-0-0682) are only present, if a HEA01 card is mounted to the IndraDrive.

2.4 New parameters, I/Os and diagnoses

New Y parameters

List of new Y parameters

ID no.	Name of parameter
Y-0-0016	Integrated PLC - Configuration
Y-0-0020	Integrated PLC - Control word
Y-0-0021	Integrated PLC - Status word
Y-0-0022	Integrated PLC - Idle time acyclic communication
Y-0-0030	Integrated PLC - Project identity
Y-0-0031	Integrated PLC - Project name
Y-0-0072	Control word process controller
Y-0-0073	Arrangement SYNAX process controller
Y-0-0160	PPC - internal features (Flash)
Y-0-0161	PPC - internal features (nvRAM)
Y-0-0296	Physical Ethernet address (MAC-ID)
Y-0-0297	Fieldbus - diagnostic message
Y-0-0298	Ethernet-HMI - diagnostic message
Y-0-0531	PPC - configured options

Fig. 2-6: New Y parameters

New C parameters

List of new C parameters

ID no.	Name of parameter
C-0-0120	Master axis - internal features (flash)
C-0-0121	Master axis - internal features (nvRAM)

Fig. 2-7: New C parameters

New A parameters

List of new A parameters

ID no.	Name of parameter
A-0-0010	Gear reduction
A-0-0039	Side register - cross tooth compensation
A-0-0040	Drive address side register controller
A-0-0041	Register control - actual value
A-0-0051	Configuration list signal status word (IndraDrive-M)
A-0-0052	Assign list signal status word (IndraDrive-M)
A-0-0053	Configuration list signal control word (IndraDrive-M)
A-0-0054	Assign list signal control word (IndraDrive-M)
A-0-0140	Following axis - internal features (flash)
A-0-0141	Following axis - internal features (nvRAM)
A-0-0182	Winder - controller output tension, positive limit
A-0-0183	Winder - controller output tension, negative limit
A-0-0184	Winder - weighting set point summation
A-0-0185	Winder - material density
A-0-0186	Winder - web width winding material
A-0-0187	Winder - friction minimum torque
A-0-0188	Winder - speed minimal friction torque
A-0-0189	Winder - inertia mechanical components
A-0-0190	Winder - taper
A-0-0191	Winder - initial diameter taper profile
A-0-0192	Winder - selection taper profile
A-0-0193	Winder - controller output tension
A-0-0194	Winder - acceleration compensation, filter time constant

Fig. 2-8: New A parameters

New inputs/outputs

New inputs

Designation I/O logic	Designation PLC	Function
_E:F#.31	SEL_CAM_BIT1	Selection cam table bit 1
_E:F#.32	TRIG_CAM_SHAFT_GEAR	Selection of trigger for cam shaft and gear switch
_E:F#.50	MOD_VAL_SYNC_REQ	Build value range for act. position data in synchronization
_E:F#.51	INP_SI_GP_E1	General purpose input E1 for the safety technology
_E:F#.52	INP_SI_GP_E2	General purpose input E2 for the safety technology
_E:F#.53	INP_SI_GP_E3	General purpose input E3 for the safety technology
_E:F#.54	INP_SI_GP_E4	General purpose input E4 for the safety technology
_E:F#.55	INP_SI_DYN_E30	Dynamization input E30 for the safety technology
_E:F#.56	CMD_VAL_S145_12	Signal control word - command value bit 12 (IndraDrive-M)
_E:F#.57	CMD_VAL_S145_13	Signal control word - command value bit 13 (IndraDrive-M)
_E:F#.58	CMD_VAL_S145_14	Signal control word - command value bit 14 (IndraDrive-M)
_E:F#.59	CMD_VAL_S145_15	Signal control word - command value bit 15 (IndraDrive-M)

Fig. 2-9: New inputs

New outputs

Designation I/O logic	Designation PLC	Function
_A:F#.50	MOD_VAL_SYNC_ACK	Value range for actual pos. data in synchronization is valid
_A:F#.53	RUN_MOD_VAL_SYNC	Building value range for actual pos. data in synchronization
_A:F#.54	OUT_SI_A10	SI status output controller (A10 of the safety technology)
_A:F#.55	OUT_SI_DRV_LOCK	SI status - safety drive interlock
_A:F#.56	ACT_VAL_S144_12	Signal status word - actual value bit 12 (IndraDrive-M)
_A:F#.57	ACT_VAL_S144_13	Signal status word - actual value bit 13 (IndraDrive-M)
_A:F#.58	ACT_VAL_S144_14	Signal status word - actual value bit 14 (IndraDrive-M)
_A:F#.59	ACT_VAL_S144_15	Signal status word - actual value bit 15 (IndraDrive-M)
_A:F#.60	OUT_SI_DRV_HALT	SI status - safety drive halt
_A:F#.61	OUT_SI_MOT_BIT0	SI status - safety motion bit 0
_A:F#.62	OUT_SI_MOT_BIT1	SI status - safety motion bit 1
_A:F#.63	OUT_SI_ERR_OPT	SI status - error shutdown by SI option module
_A:F#.64	ACK_CAM_BIT1	Acknowledge cam table bit 1

Fig. 2-10: New outputs

New diagnostic messages

C-0-0048 Error number	Dis- play	C-0-0047 Diagnostic text PPC system	C-0-0046 Diagnostic info	Binary Output	Clear with
11	F13	"RTC buffering empty, standstill of the system time"	10000h	_A:C01.02	--
13	F13	"PPC battery defective"	10000h	_A:C01.02	--
27	F27	"Reset PC interface. Reinitialization DPRAM took place."	10000h	--	--
99	F18	"RM - Master encoder range exceeded (C76 * C144 > Max{P765})"	n = address	OK A:C01.01 _A:C01.02	--
164	F15	"A-0-0008: At IndraDrive one analogue channel exists only"	n = address	OK A:C01.01 _A:C01.02	--
170	F15	"A-0-0027: Ambiguous configuration of the actual value source"	n = address	OK A:C01.01 _A:C01.02	--
205	F15	"Address of side register controller missing (A-25/A-40)"	n = address	--	--
206	F15	"Probe detection for the side register controller missing"	n = address	--	--
207	F15	"Side register controller is not parameterized"	n = address	--	--
246	F15	"Signal status word: conf. parameter/bit selection not valid"	n = address	OK A:C01.01 _A:C01.02	--
247	F15	"Signal control word: conf. parameter/bit selection not valid"	n = address	OK A:C01.01 _A:C01.02	--
265	F97	"Timeout PLC task external event 'SERCOS cyclic'"	10000h	OK A:C01.01 _A:C01.02	--

Fig. 2-11: New diagnostic messages

2.5 Changed and extended functions

Process controller cycle times

The operation of the process controller was optimized.

Four time slots are reserved for the process controller in each SERCOS cycle. There are two procedures to determine the order of the configured controllers:

- Processing in increasing order of the drive addresses,
- Sorting by the function (winding controller, register controller, tension/dancer controller).

The internal distribution is displayed with SynTop. So the process controller cycle times can be defined in a simple way.

see 3.1 "Process controller cycle times", page 3-1

Import of process controller actual values via fieldbus

The actual values for the process controller can be imported as analog signal or as a parameter via fieldbus.

Actual value source	Remark	Parameterization (Selection of the actual value source)
Analog input	Analog channel must be configured	A-0-0146, Bit 9 = 0
Parameter A-0-0027 in the fieldbus channel	A-0-0027 must be applied in the cyclic fieldbus channel	A-0-0146, Bit 9 = 1

Fig. 2-12: Actual value sources for process controllers

The actual value source is set with the configuration of SynTop.

Register controller

With IndraDrive also the probe 2 with expectancy window is supported in the drive now.

Cyclic processing of analog inputs

When processing analog values, it is differed between the following applications:

- Actual values for process controller are allocated to the controller functions and are processed in the same cycle.
- Analog signals that effect a single parameter are read and evaluated in a separate time slot.

Following axis: gear functions

Configurable actual value range

An actual value cycle in the drive, which is independent from the load revolutions of the drive, can be parameterized with bit 4 of "Drive type" (A-0-0001). Then the actual position value is not within the limits 0°...360°, but it is calculated from the current gear settings (see below).

If bit 4 is set, the "Position actual value in actual value cycle" (P-0-0753) of the drive is set automatically to the "Command value cycle" (P-0-0754).

The actual value range depends on the operating mode and the position weighting. With the parameters

- C-0-0076 "Product cycle"
- A-0-0126 "Electronic gear – output revolutions"
- A-0-0170 "Electronic gear – input revolutions"
- P-0-0755 "Gear reduction"
- X "Slave drive feed travel " (P-0-0159, **translatory**) or 360° (**rotatory**)

it results from the formulas:

$$Actual\ value\ cycle = Command\ value\ cycle = C-0-0076 * \frac{A-0-0126}{A-0-0170} * X$$

Fig. 2-13: Command/actual value cycle at phase synchronization

$$Actual\ value\ cycle = Command\ value\ cycle = C-0-0076 * \frac{A-0-0126}{A-0-0170} * X * \frac{1}{P-0-0755}$$

Fig. 2-14: Command/actual value cycle at electronic cam

Applications The actual value cycle must be set, e.g., independent from the load cycles at

- Absolute phase synchronous axes with any electronic gear ratio (e.g., 30341 / 30219).
- Axes with a register controller, which probes the position of the drive.

Note: At drives of type DiAx 03/04 and EcoDrive 03 the electronic gear cannot be changed in operation mode if bit 4 in "Drive type" (A-0-0001) is set.

Gear reduction at electronic cam

For the gear reduction in cam mode a new motion control parameter was implemented. Now the gear reduction must be entered in parameter A-0-0010 and no longer in P-0-0755.

IndraDrive: Gear change without phase switching

At a drive that works in synchronization mode with underlying position control with position actual values (in P-0-0753) independent of the cylinder revolution (A-0-0001, bit 4 = 1), so far the electronic gear could only be changed in parameterization mode. Now for a IndraDrive this is also possible in operating mode. The gear or the gear reduction can be changed when writing the control parameters

- A-0-0126 "Electronical gear - output revolutions"
- A-0-0170 "Electronical gear - input revolutions"
- A-0-0010 "Gear reduction".

After every change of this parameter in operating mode the binary output "Value range for actual pos. data in synchronization is valid" ($_A:F\#.50$) is automatically cleared.

The reference to the new actual value range can be re-established as follows:

1. Reset drive enable.
2. Setting input "Build value range for act. position data in synchronization" ($_E:F\#.50$).
The command execution is displayed at the drive display: "C3100".
The command is terminated, if output $_A:F\#.50$ is reset again.
3. With the new actual position range the absolute reference is invalid.
The output "Acknowledge reference" ($_A:F\#.03$) is cleared.
4. The absolute reference can be re-established with setting input "Set absolute reference" ($_E:F\#.25$) or "Referencing" ($_E:F\#.03$).

Thus the change of the gear or the reduction is finished.

IndraDrive: 4 cam tables

IndraDrive makes four cams available in parameters

- P-0-0072 "Cam shaft profile 1"
- P-0-0092 "Cam shaft profile 2"
- P-0-0780 "Cam shaft profile 3" **new**
- P-0-0781 "Cam shaft profile 4" **new**

where it can be switched online between them.

Switching is done with binary inputs "Selection cam table bit 0" ($_E:F\#.30$) and "Selection cam table bit 1" ($_E:F\#.31$).

$_E:F\#30$	$_E:F\#31$	Effect
0	0	Selection cam table 1
1	0	Selection cam table 2
0	1	Selection cam table 3
1	1	Selection cam table 4

Fig. 2-15: Selection cam table

The cam that is currently valid is displayed with binary outputs "Acknowledge cam table bit 0" ($_A:F\#.30$) and "Acknowledge cam table bit 1" ($_A:F\#.64$).

IndraDrive: analog channel

IndraDrive only supports one analog channel.

Trying to activate the second analog channel the PC signals error "A-0-0008: At IndraDrive one analogue channel exists only" (F 164).

IndraDrive: status messages

In IndraDrive new parameters were implemented for the transmission of control and status bits. Status messages of the drive to the MotionControl are cyclically transmitted in the "Freely configurable signal status word" (S-0-0144). The parameter "Manufacturer class 3 diagnostics" (S-0-0182) has been dropped.

The signal status is predefined that the known status bits from the "Manufacturer class 3 diagnostics" are mapped 1:1. Further on the messages for the safety technology and the cam table selection are defined automatically. The bits 12...15 are freely configurable. In the following table the status messages of IndraDrive and the known drive families (DiAx0x, EcoDrive) are opposed.

Bit-No.	S-0-0144 (IndraDrive-M)	S-0-0182 (other drives)
0	SI status output controller (safety technology: output A10)	<i>only ELS06: starting lock-out active</i>
1	 Actual speed < S-0-0124	 Actual speed < S-0-0124
2	Acknowledge cam bit 0	---
3	Acknowledge cam bit 1	---
4	---	<i>only ELS06: speed operating thresholds n2</i>
5	---	<i>only ELS06: speed operating thresholds n3</i>
6	IZP	IZP
7	---	Message 90 % LOAD
8	IN_SYNCHRONISATION	IN_SYNCHRONISATION
9	Synchronization ramp up achieved	Synchronization ramp up achieved
10	IN_ZIELPOSITION	IN_ZIELPOSITION
11	AHQ (drive halt + bit 1)	AHQ (drive halt + bit 1)
12	Freely configurable in A-0-0051/52	<i>Only SGP20: stop position reached</i>
13	Freely configurable in A-0-0051/52	---
14	Freely configurable in A-0-0051/52	---
15	Freely configurable in A-0-0051/52	---

Fig. 2-16: Status messages at IndraDrive and other drives

IndraDrive: extended oscilloscope function

The drive internal oscilloscope function was revised and extended. The essential improvements are

- 4 probe value tables (P-0-0021, P-0-0022, P-0-0145, P-0-0146)
- Probe value tables scalable up to 8192 measuring points
- Up to 100 trigger signals

Note: **The oscilloscope function of the IndraDrive is not supported by SynTop 11VRS.**
Till a version of SynTop supporting the oscilloscope function will be released, DriveTop 16VRS can be used, if necessary.

Because the maximum length of the probe value list was increased to 32 KB user data (= 8192 probe values) each, it is faced with much longer transmission times. This could lead to problems at a complete data back-up, if the timeout for the serial communication is too small.

Note: The transmission time of a complete probe value list amounts more than two minutes at a SERCOS cycle time of 8 ms. In this case the parameter "Serial communication - time out" (Y-0-0124) must be set to 140.0.

IndraDrive: SYNAX diagnosis at drive errors

So far the triple-digit drive error number was mapped to the SYNAX error number range 3000...3999 (error number in P-0-0009 was added to value 3000).

The error numbers at IndraDrive are four-digit. The first digit specifies an *error class*. Only the error classes are mapped to a collective error number when generating the SYNAX error number:

Drive error number (P-0-0009)	SYNAX error number (Y-0-0048)
2xxx	3002
3xxx	3003
4xxx	3004
6xxx	3006
8xxx	3008
9xxx	3009

Fig. 2-17: Mapping the four-digit drive error number to the SYNAX error number

The real drive error number (P-0-0009) must be taken from the clear text diagnosis in Y-0-0047.

3964R interface

The transmission of binary input/output data via the 3964R interface can be done like before via the data block 99 (DB 99) in respect to the data structure which is set in the I/O logic.

With the support of the field bus I/O parameters Y-0-0200..Y-0-0231 and Y-0-0250..Y-0-0281 by the 3964R interface now the user has the possibility to configure the transmission of binary input/output data via data blocks 101..116 in his application. The advantages for the user can be:

- I/O data are scalable and freely configurable (in the data blocks 101...116)
- the configuration of the I/O data can be changed dynamically
- the binary input data can be read back

The mode of the binary data transmission is set in the parameter "Host communication – control word" (Y-0-0033) with bit 13.

ARCNET interface

The ARCNET interface was optimized in respect to its internals and was extended in two items.

Transmission times The data transmission of the ARCNET interface is optimized. The transmission times are reduced by the factor 2 (drive parameters) up to 4 (A/C/Y parameters).

Binary inputs/outputs The transmission of binary input/output data via the ARCNET interface can be done like before via the data block 99 (DB 99) in respect to the data structure which is set in the I/O logic.

With the support of the field bus I/O parameters Y-0-0200..Y-0-0231 and Y-0-0250..Y-0-0281 by the ARCNET interface now the user has the possibility to configure the transmission of binary input/output data via data blocks 101..116 in his application. The advantages for the user can be:

- I/O data are scalable and freely configurable (in the data blocks 101...116)
- the configuration of the I/O data can be changed dynamically
- the binary input data can be read back

The mode of the binary data transmission is set in the parameter "Host communication – control word" (Y-0-0033) with bit 13.

Diagnosis at buffer overflow An overflow of the ARCNET telegram buffer is displayed like before with the operating system error 5414. This has the disadvantage that the output "PPC ready" is cleared and the error cannot be reset by the user.

SYNAX 200 version 11VRS now optional supports the output of the diagnostic message "ARCNET telegram buffer: Overflow error" (F 146) that can be reset by the input "PPC error – clear external communication error" (_E:C01.03).

The mode of the diagnosis at buffer overflow is chosen in the "Host communication – control word" (Y-0-0033) with bit 14.

Attribute list for drive parameters

To decrease the transmission times for S and P parameters, the attributes of many S and P parameters are stored on the motion control.

Parameters, where the attributes have been changed in IndraDrive, are no longer contained in the PPC internal preferred list. If such a parameter should be transmitted to a data block, it can be manually entered in the preferred list.

For this purpose the commissioning tool SynTop provides a dialog.

I/O logic

Binary I/O for IndraDrive

The IndraDrive supports digital inputs/outputs

- onboard on the drive controller
- on the option card HEA01.

The "on-board I/O" are indirectly addressed via freely configurable I/O (see section "Addressing of the integrated inputs/outputs (IndraDrive)", page 3-5).

The known symbolic names "_E:Dxx.yy" or "_A:Dxx.yy" have to be used for the 12 inputs and 8 outputs of the option card HEA01.

Compiler PARA.EXE

The version of the PARA-EXE has been adjusted because of the common version management of all SYNAX tools. Every I/O logic for SY*-11VRS must be compiled with the new version 11 of PARA.EXE.

There are no functional changes compared to version 10, but there is the logical combination:

SYNAX11 -> SynTop11 -> PARA11.

2.6 Changed and extended parameters, I/Os and diagnoses

Changed Y parameters

List of changed
Y parameters

ID no.	Name of parameters
Y-0-0005	Serial Port A device type
Y-0-0010	Serial Port B device type
Y-0-0033	Host communication - control word
Y-0-0129	Fieldbus - control bits
Y-0-0131	Configuration list - cyclic PLC process input data
Y-0-0132	Configuration list - cyclic PLC process output data
Y-0-0157	Data blocks - configurable S-/P-parameters, ID-number
Y-0-0300 - Y-0-0363	Fieldbus - PLC input variable data container 1 (Y363 = 64)
Y-0-0400 - Y-0-0463	Fieldbus - PLC output variable data container 1 (Y463 = 64)
Y-0-0508 - Y-0-0511	PPC-Visualization: target selection 1 (till 4)

Fig. 2-18: Changed Y parameters

Individual Y parameter changes

Y-0-0005 Serial Port A device type

- The default value has been changed from 1 to 3.
- The text has changed. Selection possibility 5 = PPC visualization was added.

Y-0-0010 Serial Port B device type

The text has changed. Selection possibility 5 = PPC visualization was added.

Y-0-0033 Host communication - control word

- Bit 13 for 3964R and ARCNET was added.
- The bit 14 for ARCNET was added.
- The list of the permissible combinations for the PPC-R was extended by bits 13 and 14.

Y-0-0129 Fieldbus - control bits

- Bits 23 and 24 for the Ethernet on board interface (PPC-R2x) were added.
- The default value has changed.

Y-0-0131 Configuration list - cyclic PLC process input data

- The name has changed.
- Text was added.

Y-0-0132 Configuration list - cyclic PLC process output data

- The name has changed.
- Text was added.

Y-0-0157 Data blocks - configurable S-/P-parameters, ID-number

- The parameters S-0-0100, S-0-0390, P-0-0121, P-0-0127 and P-0-0215 were cleared from the preferred list.
- Parameters S-0-0144, S-0-0145, P-0-0754, P-0-0755 and P-0-0765 were added to the preferred list.
- The parameter was removed from the group DIAGNOSES and was allocated to the group COMMUNICATION.

Y-0-0300 - Y-0-0363 Fieldbus - PLC input variable data container 1 (Y363 = 64)

- The name has changed.
- Text was added.

Y-0-0400 - Y-0-0463 Fieldbus - PLC output variable data container 1 (Y463 = 64)

- The name has changed.
- Text was added.

Y-0-0508 - Y-0-0511 PPC-Visualization: target selection 1 (till 4)

Parameter values 2 (output on X10 via IBS-ECO-LINK) and 3 (output on X16 via IBS-ECO-LINK) were added.

Changed C parameters

List of changed
C parameters

ID no.	Name of parameters
C-0-0049	Cam switch group 2 - control word
C-0-0144	RM - master encoder input revolutions

Fig. 2-19: Changed C parameters

Individual C parameter changes C-0-0049 Cam switch group 2 - control word

The drive HEA added to the bit strip.

C-0-0144 RM - master encoder input revolutions

The access was changed from "no write protection" to "write protected in operating mode".

Changed A parameters

List of changed
A parameters

ID no.	Name of parameters
A-0-0001	Axis type
A-0-0013	Adjustable parameter selection
A-0-0025	Process control - control word 1
A-0-0027	Process actual value
A-0-0095	Drive type
A-0-0146	Process control - control word 2

Fig. 2-20: Changed A parameters

Individual A parameter changes**A-0-0001 Axis type**

Bit 4 for the selection of the actual position value range was added.

A-0-0013 Adjustable parameter selection

The bit combination 1101 "Stop position x" (A-0-0056..A-0-0059) was added.

A-0-0025 Process control - control word 1

- Because of the introduction of the side register controller bits 16 and 17 were added.
- The meaning of bit 23 has changed.
- Depending on the parameterized register controller (side register controller or circumferential register controller), not all existing bits are always used.

A-0-0027 Process actual value

- A note was added to the text.
- The access was changed from "write protected" to "no write protection".

A-0-0095 Drive type

The IndraDrive M and the examples of its different drive types were added.

A-0-0146 Process control - control word 2

- Bit 9 for the selection of the actual value source was added.
- The winding controller with load cell was added.

Changed inputs/outputs

Changed inputs

Designation I/O logic	Designation PLC	Function
_E:F#.30	SEL_CAM_BIT0	Selection cam table bit 0
_E:C01.10	PLC_PD_INVALID	PLC - cyclic process output data invalid

Fig. 2-21: Changed inputs

Changed outputs

Designation I/O logic	Designation PLC	Function
_A:F#.30	ACK_CAM_BIT0	Acknowledge cam table bit 0
_A:C01.10	PLC_PD_INVALID	PLC - cyclic process input data invalid

Fig. 2-22: Changed outputs

Individual input/output changes

_E:F#.30 Selection cam table bit 0

The name has changed.

_E:C01.10 PLC - cyclic process output data invalid

The name has changed.

_A:F#.30 Acknowledge cam table bit 0

The name has changed.

_A:C01.10 PLC - cyclic process input data invalid

The name has changed.

Changed diagnostic messages

C-0-0048 Error number	Display	C-0-0047 Diagnostic text PPC system	C-0-0046 Diagnostic info	Binary output	Clear with
192	F15	"Y-0-0013: PLC-interface not allowed on PPC-R without PLC"	10000h	OK A:C01.01 _A:C01.02	--
3000+y	F98	"Drive error"	10000h	_A:F#.10	_E:F#.14

Fig. 2-23: Changed diagnostic messages

Individual diagnostic message changes

192 (F15) Y-0-0013: PLC-interface not allowed on PPC-R without PLC

The name has changed.

3000+y (F98) Drive error

The collective error numbers for the IndraDrive (y has four-digit values) were added to the text.

2.7 Phase out of functions / hardware

The programming interface *WinPCL* is not supported any more. In the course of the conversion to a new PLC platform IndraLogic V01 was introduced.

WinPCL programs can not be opened with IndraLogic. The programs can be exported from WinPCL and imported to IndraLogic. But it is necessary to rework it manually (e.g., PLC configuration).

3 Attachment: abstract of the functional description

3.1 Process controller cycle times

Real time functions, as the process controllers, are processed in the SERCOS cycle. A maximum of four process controllers can be calculated per cycle:

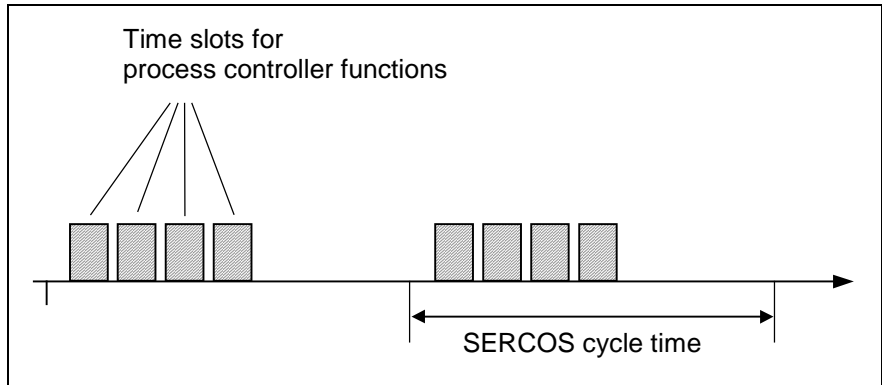

Fig. 3-1: Processing of the process controller

The cycle time of the individual controllers depends on the total number of all configured process controllers and their sorting to 4 time slots. The cycle times can be optimal adjusted to the different applications, because of a suitable distribution.

The process controllers can be distributed automatic or manual.

Cyclic distribution

At the cyclic distribution all configured process controllers are sorted in ascending order of the associated drive addresses.

Example 1

Drive	Address	Process controller function	Symbol
Unwinder	10	Winding controller with dancer	WCtrl01
Infeed	11	Tension controller	TCtrl01
Printing unit 1	01	Register controller	RCtrl01
Printing unit 2	02	Register controller	RCtrl02
Printing unit 3	03	Register controller	RCtrl03
Printing unit 4	04	Register controller	RCtrl04
Rewinder	12	Winding controller with dancer	WCtrl02

Fig. 3-2: Example 1: process controller configuration

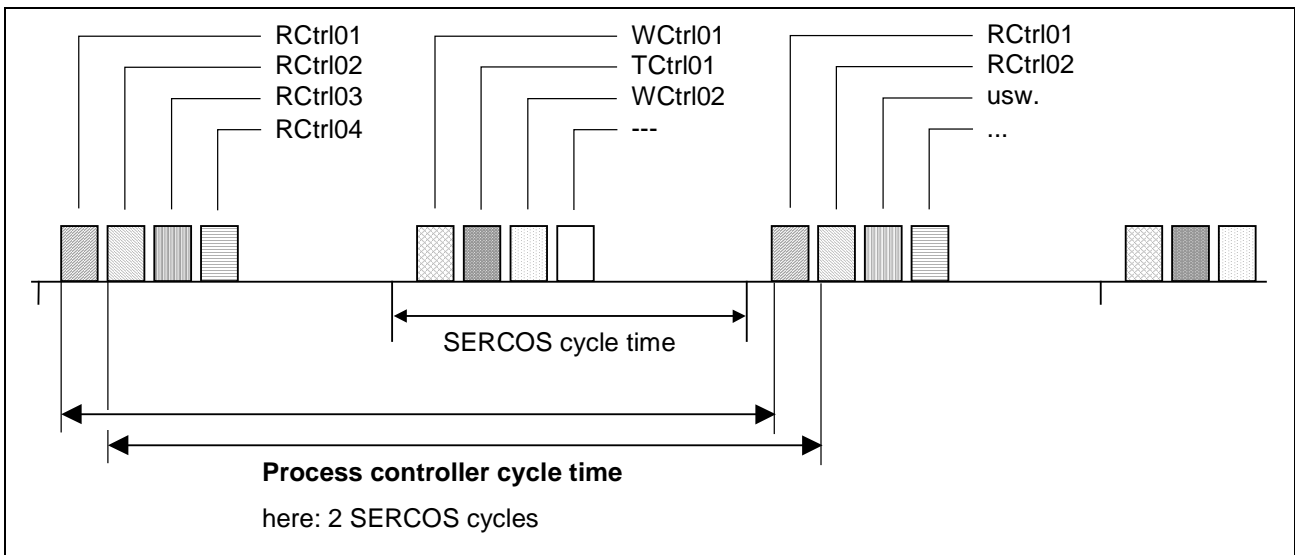

Fig. 3-3: Principle of the cyclic distribution (example 1)

Note: At cyclic distribution all process controller are processed with the same cycle time.

If the total number of the configured process controllers are not divisible by four, the rest time slots remain free (in the example of Fig. 3-3 the 4th time slot).

The result of the automatic distribution can be read out with the commissioning program SynTop.

Functional distribution

At the functional distribution all configured process controllers are merged to groups and distributed to the four time slots. The following automatic allocation applies:

Group 1 (time slot 1)	Group 2 (time slot 2)	Group 3 (time slot 3)	Group 4 (time slot 4)
register controller	- tension controller with load cell - dancer controller	- winding controller with load cell, - winding controller without sensor	winding controller with dancer

Fig. 3-4: Arrangement of the process controllers

Exactly *one* controller is processed from every group in every SERCOS cycle.

Example 2

Drive	Address	Process controller function	Symbol
Unwinder	10	Winding controller with load cell	WCtrl01
Infeed	11	Tension controller	TCtrl01
Printing unit 1	01	Register controller	RCtrl01
Printing unit 2	02	Register controller	RCtrl02
Printing unit 3	03	Register controller	RCtrl03
Printing unit 4	04	Register controller	RCtrl04
Outfeed	12	Tension controller	TCtrl02

Fig. 3-5: Example 2: Process controller configuration

Group 1 (time slot 1)	Group 2 (time slot 2)	Group 3 (time slot 3)	Group 4 (time slot 4)
RCtrl01 RCtrl02 RCtrl03 RCtrl04	TCtrl01 TCtrl02	WCtrl01	---

Fig. 3-6: Example 2: Process controller groups

The cycle time of the individual process controllers results from the number of the entries to the different groups (Fig. 3-7):

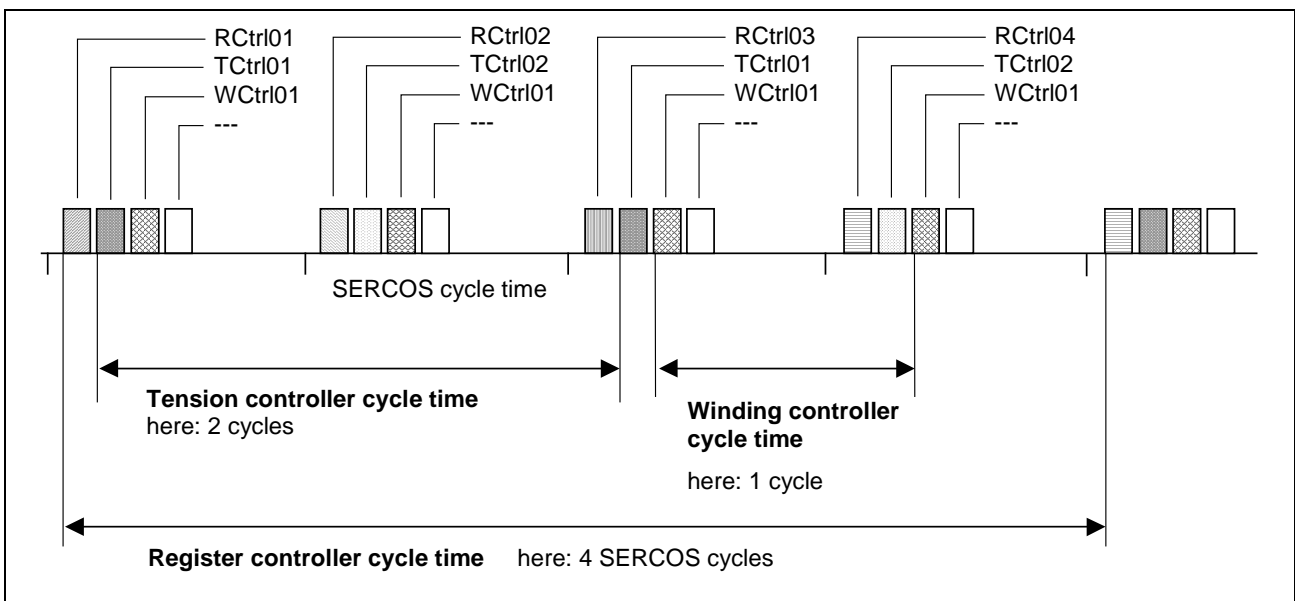

Fig. 3-7: Principle of the functional distribution (example 2)

The result of the functional distribution can be read out with the commissioning program SynTop.

3.2 Process controller actual values

Actual values for the process controller can be imported as analog signal or as parameter via the fieldbus.

Actual value source	Remark	Parameterization
Analog input	Analog input must be configured	A-0-0146, bit 9 = 0
Parameter A-0-0027 in the fieldbus channel	A-0-0027 must be applied in the cyclic fieldbus channel	A-0-0146, bit 9 = 1

Fig. 3-8: Actual value sources for process controllers

The actual value source is set with the configuration of SynTop.

3.3 Processing analog input values

Analog inputs are imported via analog inputs of the drives. Analog signals can be allocated

- to the actual values for process controllers on the PPC motion control or
- any single parameters.

Analog actual values for process controller are processed in the same time slot of a SERCOS cycle as the associated controller.

For signals that are allocated to a selected **single parameter** (e.g., as analog speed offset) a own time slot is reserved.

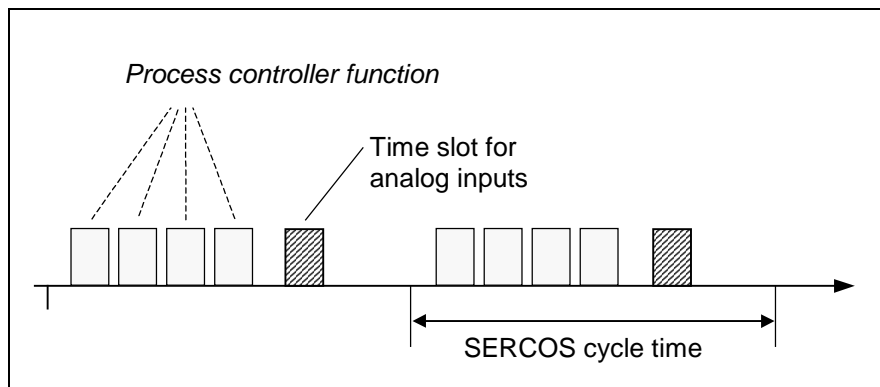

Fig. 3-9: Processing of general allocable analog inputs

One analog module is processed per time. That means that both analog inputs of a DAE card are processed in the same cycle.

3.4 I/O logic

Freely configurable inputs/outputs for IndraDrive

Four configurable following axis I/O each can be allocated to drive-internal signals or single bits. They are exchanged in the "Signal status/control word" (S-0-0144/145) in real time between drive and PPC.

Four bits are fixed allocated to the new inputs/outputs `_E:F#.56...59` and `_A:F#.56...59` in the signal/control word:

Input	Allocation signal control word (S-0-0145)	Output	Allocation signal status word (S-0-0144)
<code>_E:F#.56</code>	bit 12	<code>_A:F#.56</code>	bit 12
<code>_E:F#.57</code>	bit 13	<code>_A:F#.57</code>	bit 13
<code>_E:F#.58</code>	bit 14	<code>_A:F#.58</code>	bit 14
<code>_E:F#.59</code>	bit 15	<code>_A:F#.59</code>	bit 15

Fig. 3-10: Freely configurable I/O of the PPC in signal control/status word

The I/O configuration defines, which bit should be addressed to which drive parameter. This is done with parameters

- "Configuration list signal status word" (A-0-0051),
- "Assign list signal status word" (A-0-0052),
- "Configuration list signal control word" (A-0-0053),
- "Assign list signal control word" (A-0-0054).

Each input/output is allocated to a list entry. Fig. 3-11 shows the allocation principle with the example of the freely configurable inputs:

Input	A-0-0053	A-0-0054
<code>_E:F#.56</code>	parameter ID	bit no.
<code>_E:F#.57</code>	parameter ID	bit no.
<code>_E:F#.58</code>	parameter ID	bit no.
<code>_E:F#.59</code>	parameter ID	bit no.

Fig. 3-11: I/O configuration

Addressing of the integrated inputs/outputs (IndraDrive)

The integrated inputs/outputs on the control section of the IndraDrive are used like the freely configurable I/Os. Unlike the inputs/outputs of an optional I/O card, they are not addressed via symbolic names, but indirectly via binary control signals `_E:F#.56...59` or `_A:F#.56...59`.

To access the integrated inputs/outputs, these signals must be configured as I/O for the PPC on drive and control side.

Example:

- The 4 hardware inputs E1...E4 should be allocated to `_A:F#.56...59`.
- EA8...EA11 should be addressable via inputs `_E:F#.56...59`.

Settings on drive side:

List elem.	I/O bit (name)	P-0-0300 (parameter ID)	P-0-0301 (bit number)	P-0-0302 (0 = input, 1 = output)
1	BB
2	E1	S-0-0000 (<i>Dummy</i>)	12 (<i>Dummy</i>)	0
3	E2	S-0-0000 (<i>Dummy</i>)	13 (<i>Dummy</i>)	0
4	E3	S-0-0000 (<i>Dummy</i>)	14 (<i>Dummy</i>)	0
5	E4	S-0-0000 (<i>Dummy</i>)	15 (<i>Dummy</i>)	0
6	E5
7	Ean+6
8	EAn+7
9	EA8	S-0-0145	12	1
0	EA9	S-0-0145	13	1
11	EA10	S-0-0145	14	1
12	EA11	S-0-0145	15	1

Fig. 3-12: Configuration of the integrated inputs/outputs on drive side

Settings on control side:

Output	A-0-0051 (parameter ID)	A-0-0052 (bit number)
_A:F#.56	P-0-0303	1 (E1)
_A:F#.57	P-0-0303	2 (E2)
_A:F#.58	P-0-0303	3 (E3)
_A:F#.59	P-0-0303	4 (E4)

Fig. 3-13: Configuration of the hardware inputs E1...E4 on control side

3.5 Integrated safety technology in IndraDrive

The control sections of the drive family IndraDrive can be equipped with a "Safety technology I/O" optional module. In this way, IndraDrive is equipped with integrated safety technology, which provides the user with an universally programmable monitor for safety related motion/stopping process.

"Integrated safety technology" refers to application-related safety functions that are applicable for personal protection on machines in accordance with EN 954-1 category 3.

Safety functions

The "Safety technology I/O" optional module provides the following application related safety functions:

- Safety related standstill (stop category 1 according to EN 60204-1).
- Safety related operational stop (stop category 2 according to EN 60204-1).
- Safety related drive interlock (stop category 1 according to EN 60204-1).
- Safety monitored stopping (for functions "Safety related standstill", "Safety related operational stop", "Safety related drive interlock")
- Safety related reduced speed
- Safety related limited maximum velocity
- Safety related limited increment
- Safety related direction of motion
- Safety related absolute position
- Safety related homing (required for "Safety related limited absolute position")
- Safety diagnostic outputs
- Safety related control of a door locking device

Features of the safety technology

The safety functions can be selected via 24 V inputs on the drive controller.

The safety technology has been tested and certified by an EU prototype test of the SIBE Switzerland certification authority.

The following requirements can be implemented with the motion control SYNAX 200 in the machine or system:

- Requirements for safety-related parts of motion controls according to EN 954-1 category 3, as stipulated in EN 1010-1 (printing and paper processing machines), EN 12415 (turning machines) and EN 12417 (machining centers).
- Safety channel 1 via the SERCOS master communication.

Functionality of the safety technology

During the operation, the safety functions are monitored by the drive system. To do this, three principles for discovering sleeping errors were realized in the system:

- dual-channel data processing with structure by diversity
- cross comparison of the safety-relevant data
- dynamization of static states

These measures guarantee that a single error cannot cause the safety functions to be lost.

The degree to which this is sufficient for an existing system or machine is to be determined by the manufacturer of the system or machine using a hazard analysis according to Appendix I of guideline 98/37/EG.

Activating the safety functions

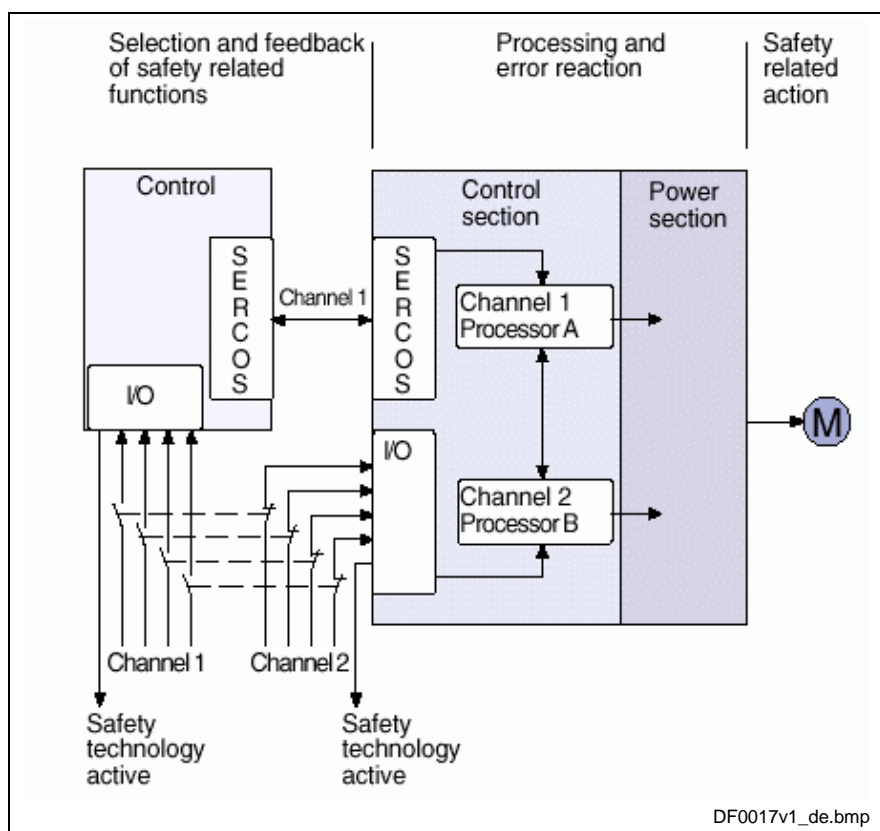

Fig. 3-14: Dual-channel activating of the safety functions

The safety channel 1 is indirectly activated via the SERCOS interface of SYNAX 200.

The safety channel 2 is directly activated via the input interface of the drive controller.

Each of those four safety inputs can be allocated to one of the following control elements with the commissioning tool SynTop:

- Operating mode selection switch(BA)
- Drive interlock (ASP)
- Enabling control (ZT)
- Home switch (REF)
- Safety switch 1 (S1)
- Safety switch 2 (S2)

The safety functions are activated with the four following axis inputs `_E:F#.51...54`. These are forwarded with the signal control word S-0-0145 via the SERCOS real time channel to the drive.

4 Service & Support

4.1 Helpdesk

Unser Kundendienst-Helpdesk im Hauptwerk Lohr am Main steht Ihnen mit Rat und Tat zur Seite. Sie erreichen uns

- telefonisch - by phone:
über Service Call Entry Center
- via Service Call Entry Center

Our service helpdesk at our headquarters in Lohr am Main, Germany can assist you in all kinds of inquiries. Contact us

49 (0) 9352 40 50 60

Mo-Fr 07:00-18:00
Mo-Fr 7:00 am - 6:00 pm

- per Fax - by fax:

+49 (0) 9352 40 49 41

- per e-Mail - by e-mail: service.svc@boschrexroth.de

4.2 Service-Hotline

Außerhalb der Helpdesk-Zeiten ist der Service direkt ansprechbar unter

After helpdesk hours, contact our service department directly at

+49 (0) 171 333 88 26

oder - or

+49 (0) 172 660 04 06

4.3 Internet

Unter www.boschrexroth.com finden Sie ergänzende Hinweise zu Service, Reparatur und Training sowie die **aktuellen** Adressen *) unserer auf den folgenden Seiten aufgeführten Vertriebs- und Servicebüros.



Verkaufsniederlassungen



Niederlassungen mit Kundendienst

Außerhalb Deutschlands nehmen Sie bitte zuerst Kontakt mit unserem für Sie nächstgelegenen Ansprechpartner auf.

*) Die Angaben in der vorliegenden Dokumentation können seit Drucklegung überholt sein.

At www.boschrexroth.com you may find additional notes about service, repairs and training in the Internet, as well as the **actual** addresses *) of our sales- and service facilities figuring on the following pages.



sales agencies



offices providing service

Please contact our sales / service office in your area first.

*) Data in the present documentation may have become obsolete since printing.

4.4 Vor der Kontaktaufnahme... - Before contacting us...

Wir können Ihnen schnell und effizient helfen wenn Sie folgende Informationen bereithalten:

1. detaillierte Beschreibung der Störung und der Umstände.
2. Angaben auf dem Typenschild der betreffenden Produkte, insbesondere Typenschlüssel und Seriennummern.
3. Tel./Faxnummern und e-Mail-Adresse, unter denen Sie für Rückfragen zu erreichen sind.

For quick and efficient help, please have the following information ready:

1. Detailed description of the failure and circumstances.
2. Information on the type plate of the affected products, especially type codes and serial numbers.
3. Your phone/fax numbers and e-mail address, so we can contact you in case of questions.

4.5 Kundenbetreuungsstellen - Sales & Service Facilities

Deutschland – Germany

vom Ausland:
from abroad:

(0) nach Landeskennziffer weglassen!
don't dial (0) after country code!

Vertriebsgebiet Mitte Germany Centre Rexroth Indramat GmbH Bgm.-Dr.-Nebel-Str. 2 / Postf. 1357 97816 Lohr am Main / 97803 Lohr Kompetenz-Zentrum Europa Tel.: +49 (0)9352 40-0 Fax: +49 (0)9352 40-4885	SERVICE CALL ENTRY CENTER MO – FR von 07:00 - 18:00 Uhr from 7 am – 6 pm Tel. +49 (0) 9352 40 50 60 service.svc@boschrexroth.de	SERVICE HOTLINE MO – FR von 17:00 - 07:00 Uhr from 5 pm - 7 am + SA / SO Tel.: +49 (0)172 660 04 06 oder / or Tel.: +49 (0)171 333 88 26	SERVICE ERSATZTEILE / SPARES verlängerte Ansprechzeit - extended office time - ♦ nur an Werktagen - only on working days - ♦ von 07:00 - 18:00 Uhr - from 7 am - 6 pm - Tel. +49 (0) 9352 40 42 22
Vertriebsgebiet Süd Germany South Bosch Rexroth AG Landshuter Allee 8-10 80637 München Tel.: +49 (0)89 127 14-0 Fax: +49 (0)89 127 14-490	Vertriebsgebiet West Germany West Bosch Rexroth AG Regionalzentrum West Borsigstrasse 15 40880 Ratingen Tel.: +49 (0)2102 409-0 Fax: +49 (0)2102 409-406 +49 (0)2102 409-430	Gebiet Südwest Germany South-West Bosch Rexroth AG Service-Regionalzentrum Süd-West Siemensstr.1 70736 Fellbach Tel.: +49 (0)711 51046-0 Fax: +49 (0)711 51046-248	
Vertriebsgebiet Nord Germany North Bosch Rexroth AG Walsroder Str. 93 30853 Langenhagen Tel.: +49 (0) 511 72 66 57-0 Service: +49 (0) 511 72 66 57-256 Fax: +49 (0) 511 72 66 57-93 Service: +49 (0) 511 72 66 57-783	Vertriebsgebiet Mitte Germany Centre Bosch Rexroth AG Regionalzentrum Mitte Waldecker Straße 13 64546 Mörfelden-Walldorf Tel.: +49 (0) 61 05 702-3 Fax: +49 (0) 61 05 702-444	Vertriebsgebiet Ost Germany East Bosch Rexroth AG Beckerstraße 31 09120 Chemnitz Tel.: +49 (0)371 35 55-0 Fax: +49 (0)371 35 55-333	Vertriebsgebiet Ost Germany East Bosch Rexroth AG Regionalzentrum Ost Walter-Köhn-Str. 4d 04356 Leipzig Tel.: +49 (0)341 25 61-0 Fax: +49 (0)341 25 61-111

Europa (West) - Europe (West)

vom Ausland: (0) nach Landeskennziffer weglassen, **Italien:** 0 nach Landeskennziffer mitwählen
from abroad: don't dial (0) after country code, **Italy:** dial 0 after country code

<p>Austria - Österreich</p> <p>Bosch Rexroth GmbH Electric Drives & Controls Stachegasse 13 1120 Wien</p> <p>Tel.: +43 (0)1 985 25 40 Fax: +43 (0)1 985 25 40-93</p>	<p>Austria – Österreich</p> <p>Bosch Rexroth GmbH Electric Drives & Controls Industriepark 18 4061 Pasching</p> <p>Tel.: +43 (0)7221 605-0 Fax: +43 (0)7221 605-21</p>	<p>Belgium - Belgien</p> <p>Bosch Rexroth AG Electric Drives & Controls Industrielaan 8 1740 Ternat</p> <p>Tel.: +32 (0)2 5830719 - service: +32 (0)2 5830717 Fax: +32 (0)2 5830731 service@boschrexroth.be</p>	<p>Denmark - Dänemark</p> <p>BEC A/S Zinkvej 6 8900 Randers</p> <p>Tel.: +45 (0)87 11 90 60 Fax: +45 (0)87 11 90 61</p>
<p>Great Britain – Großbritannien</p> <p>Bosch Rexroth Ltd. Electric Drives & Controls Broadway Lane, South Cerney Cirencester, Glos GL7 5UH</p> <p>Tel.: +44 (0)1285 863000 Fax: +44 (0)1285 863030 sales@boschrexroth.co.uk service@boschrexroth.co.uk</p>	<p>Finland - Finnland</p> <p>Bosch Rexroth Oy Electric Drives & Controls Ansatie 6 017 40 Vantaa</p> <p>Tel.: +358 (0)9 84 91-11 Fax: +358 (0)9 84 91-13 60</p>	<p>France - Frankreich</p> <p>Bosch Rexroth SAS Electric Drives & Controls Avenue de la Trentaine (BP. 74) 77503 Chelles Cedex</p> <p>Tel.: +33 (0)164 72-70 00 Fax: +33 (0)164 72-63 00 Hotline: +33 (0)608 33 43 28</p>	<p>France - Frankreich</p> <p>Bosch Rexroth SAS Electric Drives & Controls ZI de Thibaud, 20 bd. Thibaud (BP. 1751) 31084 Toulouse</p> <p>Tel.: +33 (0)5 61 43 61 87 Fax: +33 (0)5 61 43 94 12</p>
<p>France – Frankreich</p> <p>Bosch Rexroth SAS Electric Drives & Controls 91, Bd. Irène Joliot-Curie 69634 Vénissieux – Cedex</p> <p>Tel.: +33 (0)4 78 78 53 65 Fax: +33 (0)4 78 78 53 62</p>	<p>Italy - Italien</p> <p>Bosch Rexroth S.p.A. Via G. Di Vittoria, 1 20063 Cernusco S/N.MI</p> <p>Tel.: +39 02 92 365 1 +39 02 92 365 326 Fax: +39 02 92 365 500 +39 02 92 365 516378</p>	<p>Italy - Italien</p> <p>Bosch Rexroth S.p.A. Via Paolo Veronesi, 250 10148 Torino</p> <p>Tel.: +39 011 224 88 11 Fax: +39 011 224 88 30</p>	<p>Italy - Italien</p> <p>Bosch Rexroth S.p.A. Via del Progresso, 16 (Zona Ind.) 35020 Padova</p> <p>Tel.: +39 049 8 70 13 70 Fax: +39 049 8 70 13 77</p>
<p>Italy - Italien</p> <p>Bosch Rexroth S.p.A. Via Mascia, 1 80053 Castellammare di Stabia NA</p> <p>Tel.: +39 081 8 71 57 00 Fax: +39 081 8 71 68 85</p>	<p>Italy - Italien</p> <p>Bosch Rexroth S.p.A. Via Isonzo, 61 40033 Casalecchio di Reno (Bo)</p> <p>Tel.: +39 051 29 86 430 Fax: +39 051 29 86 490</p>	<p>Netherlands - Niederlande/Holland</p> <p>Bosch Rexroth Services B.V. Technical Services Kruisbroeksestraat 1 (P.O. Box 32) 5281 RV Boxtel</p> <p>Tel.: +31 (0) 411 65 16 40 +31 (0) 411 65 17 27 Fax: +31 (0) 411 67 78 14 +31 (0) 411 68 28 60 services@boschrexroth.nl</p>	<p>Netherlands – Niederlande/Holland</p> <p>Bosch Rexroth B.V. Kruisbroeksestraat 1 (P.O. Box 32) 5281 RV Boxtel</p> <p>Tel.: +31 (0) 411 65 19 51 Fax: +31 (0) 411 65 14 83 www.boschrexroth.nl</p>
<p>Norway - Norwegen</p> <p>Bosch Rexroth AS Electric Drives & Controls Berghagan 1 or: Box 3007 1405 Ski-Langhus 1402 Ski</p> <p>Tel.: +47 (0)64 86 41 00 Fax: +47 (0)64 86 90 62 jul.ruud@rexroth.no</p>	<p>Spain - Spanien</p> <p>Bosch Rexroth S.A. Electric Drives & Controls Centro Industrial Santiga Obradors s/n 08130 Santa Perpetua de Mogoda Barcelona</p> <p>Tel.: +34 9 37 47 94 00 Fax: +34 9 37 47 94 01</p>	<p>Spain – Spanien</p> <p>Goimendi S.A. Electric Drives & Controls Parque Empresarial Zuatzu C/ Francisco Grandmontagne no.2 20018 San Sebastian</p> <p>Tel.: +34 9 43 31 84 21 - service: +34 9 43 31 84 56 Fax: +34 9 43 31 84 27 - service: +34 9 43 31 84 60 sat.indramat@goimendi.es</p>	<p>Sweden - Schweden</p> <p>Bosch Rexroth AB Electric Drives & Controls - Varuvågen 7 (Service: Konsumentvägen 4, Älfsjö) 125 81 Stockholm</p> <p>Tel.: +46 (0)8 727 92 00 Fax: +46 (0)8 647 32 77</p>
<p>Sweden - Schweden</p> <p>Bosch Rexroth AB Electric Drives & Controls Ekvåndan 7 254 67 Helsingborg</p> <p>Tel.: +46 (0) 42 38 88 -50 Fax: +46 (0) 42 38 88 -74</p>	<p>Switzerland West - Schweiz West</p> <p>Bosch Rexroth Suisse SA Electric Drives & Controls Rue du village 1 1020 Renens</p> <p>Tel.: +41 (0)21 632 84 20 Fax: +41 (0)21 632 84 21</p>	<p>Switzerland East - Schweiz Ost</p> <p>Bosch Rexroth Schweiz AG Electric Drives & Controls Hemrietstrasse 2 8863 Buttikon</p> <p>Tel. +41 (0) 55 46 46 111 Fax +41 (0) 55 46 46 222</p>	

Europa (Ost) - Europe (East)

vom Ausland: (0) nach Landeskennziffer weglassen
from abroad: don't dial (0) after country code

Czech Republic - Tschechien	Czech Republic - Tschechien	Hungary - Ungarn	Poland – Polen
Bosch -Rexroth, spol.s.r.o. Hviezdoslavova 5 627 00 Brno Tel.: +420 (0)5 48 126 358 Fax: +420 (0)5 48 126 112	DEL a.s. Strojirenská 38 591 01 Zdar nad Sázavou Tel.: +420 566 64 3144 Fax: +420 566 62 1657	Bosch Rexroth Kft. Angol utca 34 1149 Budapest Tel.: +36 (1) 422 3200 Fax: +36 (1) 422 3201	Bosch Rexroth Sp.zo.o. ul. Staszica 1 05-800 Pruszków Tel.: +48 22 738 18 00 – service: +48 22 738 18 46 Fax: +48 22 758 87 35 – service: +48 22 738 18 42
Poland – Polen	Romania - Rumänien	Romania - Rumänien	Russia - Russland
Bosch Rexroth Sp.zo.o. Biuro Poznan ul. Dabrowskiego 81/85 60-529 Poznan Tel.: +48 061 847 64 62 /-63 Fax: +48 061 847 64 02	East Electric S.R.L. Bdul Basarabia no.250, sector 3 73429 Bucuresti Tel./Fax.: +40 (0)21 255 35 07 +40 (0)21 255 77 13 Fax: +40 (0)21 725 61 21 eastel@rdsnet.ro	Bosch Rexroth Sp.zo.o. Str. Drobety nr. 4-10, app. 14 70258 Bucuresti, Sector 2 Tel.: +40 (0)1 210 48 25 +40 (0)1 210 29 50 Fax: +40 (0)1 210 29 52	Bosch Rexroth OOO Wjatskaja ul. 27/15 127015 Moskau Tel.: +7-095-785 74 78 +7-095 785 74 79 Fax: +7 095 785 74 77 laura.kanina@boschrexroth.ru
Russia - Russland	Turkey - Türkei	Slowenia - Slowenien	
ELMIS 10, Internationalnaya 246640 Gomel, Belarus Tel.: +375/ 232 53 42 70 +375/ 232 53 21 69 Fax: +375/ 232 53 37 69 elmis_ltd@yahoo.com	Bosch Rexroth Otomasyon San & Tic. A..S. Fevzi Cakmak Cad No. 3 34295 Sefaköy - Istanbul Tel.: +90 212 413 34-00 Fax: +90 212 413 34-17	DOMEL Otoki 21 64 228 Zelezniki Tel.: +386 5 5117 152 Fax: +386 5 5117 225 brane.ozebek@domel.si	

Africa, Asia, Australia – incl. Pacific Rim

<p>Australia - Australien</p> <p>AIMS - Australian Industrial Machinery Services Pty. Ltd. 28 Westside Drive Laverton North Vic 3026 Melbourne</p> <p>Tel.: +61 3 93 59 0228 Fax: +61 3 93 59 0286 Hotline: +61 4 19 369 195 enquires@aimservices.com.au</p>	<p>Australia - Australien</p> <p>Bosch Rexroth Pty. Ltd. No. 7, Endeavour Way Braeside Victoria, 31 95 Melbourne</p> <p>Tel.: +61 3 95 80 39 33 Fax: +61 3 95 80 17 33 mel@rexroth.com.au</p>	<p>China</p> <p>Shanghai Bosch Rexroth Hydraulics & Automation Ltd. Waigaoqiao, Free Trade Zone No.122, Fu Te Dong Yi Road Shanghai 200131 - P.R.China</p> <p>Tel.: +86 21 58 66 30 30 Fax: +86 21 58 66 55 23 richard.yang_sh@boschrexroth.com.cn gf.zhu_sh@boschrexroth.com.cn</p>	<p>China</p> <p>Shanghai Bosch Rexroth Hydraulics & Automation Ltd. 4/f, Marine Tower No.1, Pudong Avenue Shanghai 200120 - P.R.China</p> <p>Tel.: +86 21 68 86 15 88 Fax: +86 21 58 40 65 77</p>
<p>China</p> <p>Bosch Rexroth China Ltd. 15/F China World Trade Center 1, Jianguomenwai Avenue Beijing 100004, P.R.China</p> <p>Tel.: +86 10 65 05 03 80 Fax: +86 10 65 05 03 79</p>	<p>China</p> <p>Bosch Rexroth China Ltd. Guangzhou Repres. Office Room 1014-1016, Metro Plaza, Tian He District, 183 Tian He Bei Rd Guangzhou 510075, P.R.China</p> <p>Tel.: +86 20 8755-0030 +86 20 8755-0011 Fax: +86 20 8755-2387</p>	<p>China</p> <p>Bosch Rexroth (China) Ltd. A-5F., 123 Lian Shan Street Sha He Kou District Dalian 116 023, P.R.China</p> <p>Tel.: +86 411 46 78 930 Fax: +86 411 46 78 932</p>	<p>China</p> <p>Melchers GmbH BRC-SE, Tightening & Press-fit 13 Floor Est Ocean Centre No.588 Yanan Rd. East 65 Yanan Rd. West Shanghai 200001</p> <p>Tel.: +86 21 6352 8848 Fax: +86 21 6351 3138</p>
<p>Hongkong</p> <p>Bosch Rexroth (China) Ltd. 6th Floor, Yeung Yiu Chung No.6 Ind Bldg. 19 Cheung Shun Street Cheung Sha Wan, Kowloon, Hongkong</p> <p>Tel.: +852 22 62 51 00 Fax: +852 27 41 33 44 alexis.siu@boschrexroth.com.hk</p>	<p>India - Indien</p> <p>Bosch Rexroth (India) Ltd. Electric Drives & Controls Plot. No.96, Phase III Peenya Industrial Area Bangalore – 560058</p> <p>Tel.: +91 80 51 17 0-211...-218 Fax: +91 80 83 94 345 +91 80 83 97 374 mohanvelu.t@boschrexroth.co.in</p>	<p>India - Indien</p> <p>Bosch Rexroth (India) Ltd. Electric Drives & Controls Advance House, II Floor Ark Industrial Compound Narol Naka, Makwana Road Andheri (East), Mumbai - 400 059</p> <p>Tel.: +91 22 28 56 32 90 +91 22 28 56 33 18 Fax: +91 22 28 56 32 93 singh.op@boschrexroth.co.in</p>	<p>India - Indien</p> <p>Bosch Rexroth (India) Ltd. S-10, Green Park Extension New Delhi – 110016</p> <p>Tel.: +91 11 26 56 65 25 +91 11 26 56 65 27 Fax: +91 11 26 56 68 87 koul.rp@boschrexroth.co.in</p>
<p>Indonesia - Indonesien</p> <p>PT. Bosch Rexroth Building # 202, Cilandak Commercial Estate Jl. Cilandak KKO, Jakarta 12560</p> <p>Tel.: +62 21 7891169 (5 lines) Fax: +62 21 7891170 - 71</p>	<p>Japan</p> <p>Bosch Rexroth Automation Corp. Service Center Japan Yutakagaoka 1810, Meito-ku, NAGOYA 465-0035, Japan</p> <p>Tel.: +81 52 777 88 41 +81 52 777 88 53 +81 52 777 88 79 Fax: +81 52 777 89 01</p>	<p>Japan</p> <p>Bosch Rexroth Automation Corp. Electric Drives & Controls 1F, I.R. Building Nakamachidai 4-26-44, Tsuzuki-ku YOKOHAMA 224-0041, Japan</p> <p>Tel.: +81 45 942 72 10 Fax: +81 45 942 03 41</p>	<p>Korea</p> <p>Bosch Rexroth-Korea Ltd. Electric Drives and Controls Bongwoo Bldg. 7FL, 31-7, 1Ga Jangchoong-dong, Jung-gu Seoul, 100-391</p> <p>Tel.: +82 234 061 813 Fax: +82 222 641 295</p>
<p>Korea</p> <p>Bosch Rexroth-Korea Ltd. 1515-14 Dadae-Dong, Saha-Ku Electric Drives & Controls Pusan Metropolitan City, 604-050</p> <p>Tel.: +82 51 26 00 741 Fax: +82 51 26 00 747 gyhan@rexrothkorea.co.kr</p>	<p>Malaysia</p> <p>Bosch Rexroth Sdn.Bhd. 11, Jalan U8/82, Seksyen U8 40150 Shah Alam Selangor, Malaysia</p> <p>Tel.: +60 3 78 44 80 00 Fax: +60 3 78 45 48 00 hockhwa@hotmail.com rexroth1@tm.net.my</p>	<p>Singapore - Singapur</p> <p>Bosch Rexroth Pte Ltd 15D Tuas Road Singapore 638520</p> <p>Tel.: +65 68 61 87 33 Fax: +65 68 61 18 25 sanjay.nemade@boschrexroth.com.sg</p>	<p>South Africa - Südafrika</p> <p>TECTRA Automation (Pty) Ltd. 71 Watt Street, Meadowdale Edenvale 1609</p> <p>Tel.: +27 11 971 94 00 Fax: +27 11 971 94 40 Hotline: +27 82 903 29 23 georgv@tectra.co.za</p>
<p>Taiwan</p> <p>Bosch Rexroth Co., Ltd. Taichung Branch 1F., No. 29, Fu-Ann 5th Street, Xi-Tun Area, Taichung City Taiwan, R.O.C.</p> <p>Tel.: +886 - 4 -23580400 Fax: +886 - 4 -23580402 charlie.chen@boschrexroth.com.tw jim.lin@boschrexroth.com.tw david.lai@boschrexroth.com.tw</p>	<p>Thailand</p> <p>NC Advance Technology Co. Ltd. 59/76 Moo 9 Ramintra road 34 Tharang, Bangkhen, Bangkok 10230</p> <p>Tel.: +66 2 943 70 62 +66 2 943 71 21 Fax: +66 2 509 23 62 sonkawin@hotmail.com</p>		

Nordamerika – North America

USA Headquarters - Hauptniederlassung Bosch Rexroth Corporation Electric Drives & Controls 5150 Prairie Stone Parkway Hoffman Estates, IL 60192-3707 Tel.: +1 847 6 45 36 00 Fax: +1 847 6 45 62 01 servicebrc@boschrexroth-us.com repairbrc@boschrexroth-us.com	USA Central Region - Mitte Bosch Rexroth Corporation Electric Drives & Controls Central Region Technical Center 1701 Harmon Road Auburn Hills, MI 48326 Tel.: +1 248 3 93 33 30 Fax: +1 248 3 93 29 06	USA Southeast Region - Südwest Bosch Rexroth Corporation Electric Drives & Controls Southeastern Technical Center 3625 Swiftwater Park Drive Suwanee, Georgia 30124 Tel.: +1 770 9 32 32 00 Fax: +1 770 9 32 19 03	USA SERVICE-HOTLINE - 7 days x 24hrs - +1-800-REX-ROTH +1-800-739-7684
USA East Region – Ost Bosch Rexroth Corporation Electric Drives & Controls Charlotte Regional Sales Office 14001 South Lakes Drive Charlotte, North Carolina 28273 Tel.: +1 704 5 83 97 62 +1 704 5 83 14 86	USA Northeast Region – Nordost Bosch Rexroth Corporation Electric Drives & Controls Northeastern Technical Center 99 Rainbow Road East Granby, Connecticut 06026 Tel.: +1 860 8 44 83 77 Fax: +1 860 8 44 85 95	USA West Region – West Bosch Rexroth Corporation 7901 Stoneridge Drive, Suite 220 Pleasant Hill, California 94588 Tel.: +1 925 227 10 84 Fax: +1 925 227 10 81	
Canada East - Kanada Ost Bosch Rexroth Canada Corporation Burlington Division 3426 Mainway Drive Burlington, Ontario Canada L7M 1A8 Tel.: +1 905 335 55 11 Fax: +1 905 335-41 84 michael.moro@boschrexroth.ca	Canada West - Kanada West Bosch Rexroth Canada Corporation 5345 Goring St. Burnaby, British Columbia Canada V7J 1R1 Tel.: +1 604 205-5777 Fax: +1 604 205-6944 david.gunby@boschrexroth.ca	Mexico Bosch Rexroth Mexico S.A. de C.V. Calle Neptuno 72 Unidad Ind. Vallejo 07700 Mexico, D.F. Tel.: +52 55 57 54 17 11 Fax: +52 55 57 54 50 73 mariofelipe.hernandez@boschrexroth.com.mx	Mexico Bosch Rexroth S.A. de C.V. Calle Argentina No 3913 Fracc. las Torres 64930 Monterrey, N.L. Tel.: +52 81 83 65 22 53 +52 81 83 65 89 11 +52 81 83 49 80 91 Fax: +52 81 83 65 52 80 mario.quiroga@boschrexroth.com.mx

Südamerika – South America

Argentina - Argentinien Bosch Rexroth S.A.I.C. "The Drive & Control Company" Acassusso 48 41/47 1605 Munro Provincia de Buenos Aires Tel.: +54 11 4756 01 40 Fax: +54 11 4756 01 36 victor.jabif@boschrexroth.com.ar	Argentina - Argentinien NAKASE Servicio Tecnico CNC Calle 49, No. 5764/66 B1653AOX Villa Balester Provincia de Buenos Aires Tel.: +54 11 4768 36 43 Fax: +54 11 4768 24 13 nakase@usa.net nakase@nakase.com gerencia@nakase.com (Service)	Brazil - Brasilien Bosch Rexroth Ltda. Av. Tégula, 888 Ponte Alta, Atibaia SP CEP 12942-440 Tel.: +55 11 4414 56 92 +55 11 4414 56 84 Fax sales: +55 11 4414 57 07 Fax serv.: +55 11 4414 56 86 alexandre.wittwer@rexroth.com.br	Brazil - Brasilien Bosch Rexroth Ltda. R. Dr.Humberto Pinheiro Vieira, 100 Distrito Industrial [Caixa Postal 1273] 89220-390 Joinville - SC Tel./Fax: +55 47 473 58 33 Mobil: +55 47 9974 6645 prochnow@zaz.com.br
Columbia - Kolumbien Reflutec de Colombia Ltda. Calle 37 No. 22-31 Santafé de Bogotá, D.C. Colombia Tel.: +57 1 368 82 67 +57 1 368 02 59 Fax: +57 1 268 97 37 reflutec@neutel.com.co reflutec@007mundo.com			

Bosch Rexroth AG
Electric Drives and Controls
Postfach 13 57
97803 Lohr, Deutschland
Bgm.-Dr.-Nebel-Str. 2
97816 Lohr, Deutschland
Tel. +49 (0)93 52-40-50 60
Fax +49 (0)93 52-40-49 4 1
service.svc@boschrexroth.de
www.boschrexroth.com

