

LIQUID LEVEL SENSORS

RS Series – Right Angle Liquid Level Sensor

RS801-51

Design Features

- High or low level sensing
- Internal & External fit
- Reed Switch reliability
- Silicone sealing components
- Easy installation

Product Comments

- UL listed model, File E98428
- Normally open or normally closed by float reversal
- Suitable for a wide range of liquids
- Side entry with Vertical Stem/Float travel
- Polypropylene Materials

Typical Applications

- Waste Water Level
- Coolant level indication
- Drinking water level
- Cooling systems
- Water high or low Level



Material, Design and Operation

Mounting:	Side Entry
Material:	Polypropylene
Fitting	Internal & External Fitting
Contact Form:	Form A – SPST
Contact Material:	Ruthenium
Maximum Switching Volts:	100 VAC
Maximum Switching Current:	1.0
Maximum Power:	15 Watts
Housing Temperature Range °C:	80
Housing Material:	Glass Filled Polypropylene
Housing Colour:	Charcoal
Float Material:	Glass Filled Polypropylene
Connection Type:	Stripped Cables
Cable Type:	2 x 18AWG 32/0.2mm PVC insulated 0.5m long to UL/CSA/BS6361
Cable Colour:	Black/Black
Minimum Specific Gravity:	0.85
Operating Temperature Range °C:	80
Operating Pressure BAR:	4
Sealing Components:	Silicone
Mounting Shock:	50g for 11ms duration
Mounting Vibration:	35g up to 500Hz
Operate Mode:	N/C with float down

Line Drawing

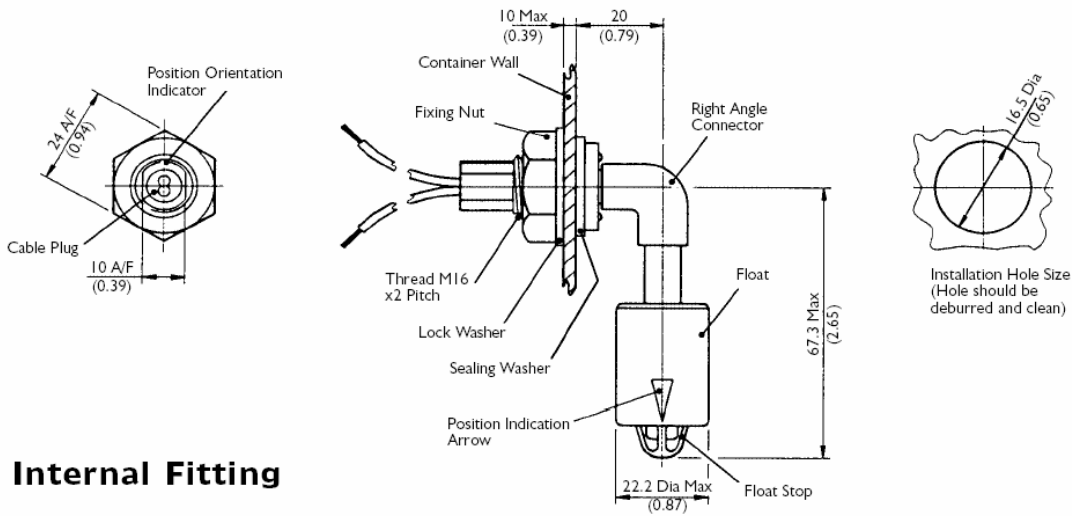

Internal Fitting

INTERNAL FITTING

CONTAINER WALL
(THICKNESS MAX 10mm, MIN 1mm)

NOTE! DRILL 0.65" OR 16.5mm HOLE,
ENSURE FREE FROM SWarf AND
SHARP EDGES.

LOCK WASHER

FIXING NUT

NOTE! MAX TORQUE 3lbs/ft
OR 4Nm.

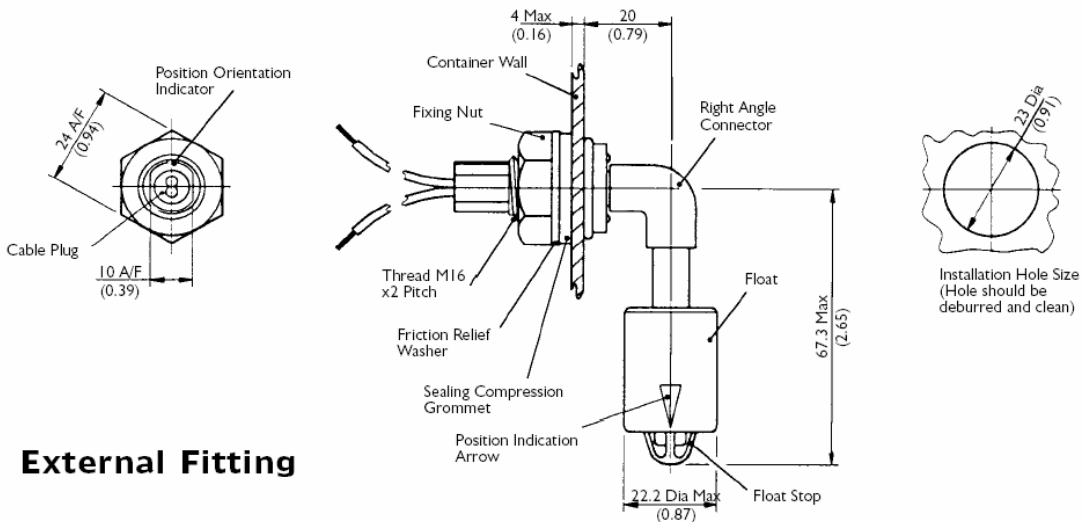
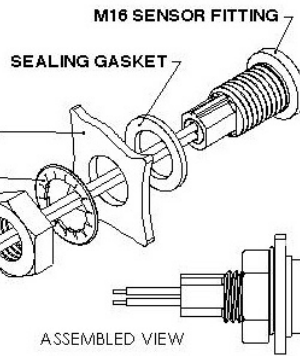

External Fitting

EXTERNAL FITTING

CONTAINER WALL
(THICKNESS MAX 4mm, MIN 1mm)

NOTE! DRILL 0.9" OR 23mm HOLE,
ENSURE FREE FROM SWarf AND
SHARP EDGES.

SEALING GROMMET

FRICITION RELIEF
WASHER

FIXING NUT

NOTE! MAX TORQUE 2lbs/ft
OR 2.67Nm.

