

HMR2300

Characteristics	Conditions	Min	Typ	Max	Units
Digital I/O Timing (See Timing Diagrams)					
T_{RESP}	*dd Commands (dd = Device ID) *ddP *ddR, *ddS, *ddT *ddC *ddQ *99 Commands *99Q	1.9	2 3 6 40 $2+(dd \times 80)$ $2+(dd \times 40)$ $2+(dd \times 120)$	2.2 3.2 6.2 60 $2+Typ$ $2+Typ$ $2+Typ$	msec
T_{DELAY}	*dd Commands (dd = Device ID) *99 Commands	39	40 $dd \times 40$	41 $2+Typ$	msec
T_{BYTE}	9600 19,200		1.04 0.52		msec
$T_{STARTUP}$	Power Applied to End of Start-Up Message		50	80	msec

BLOCK DIAGRAM

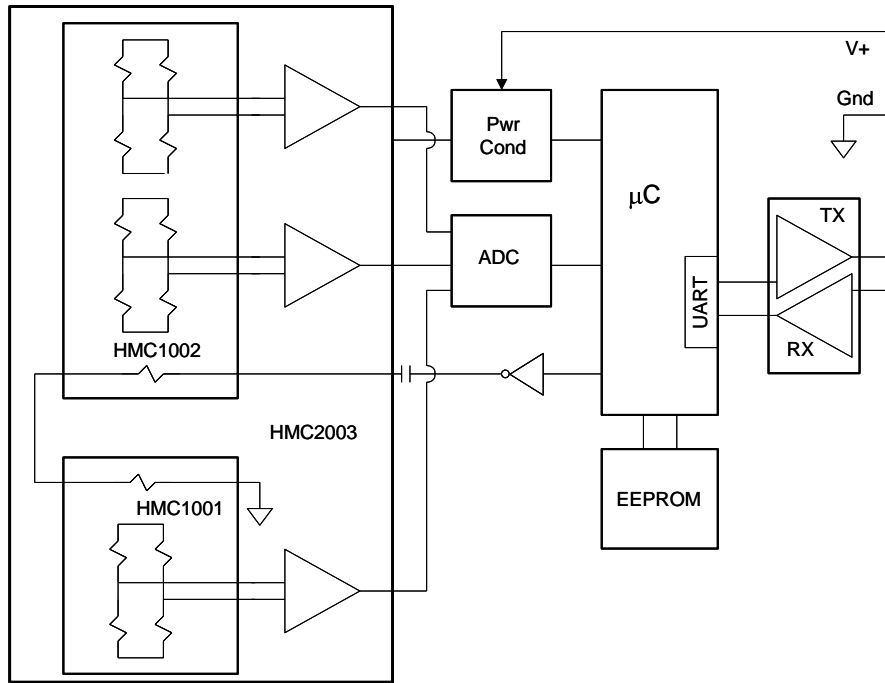

RS-232 COMMUNICATIONS (Timing is Not to Scale)

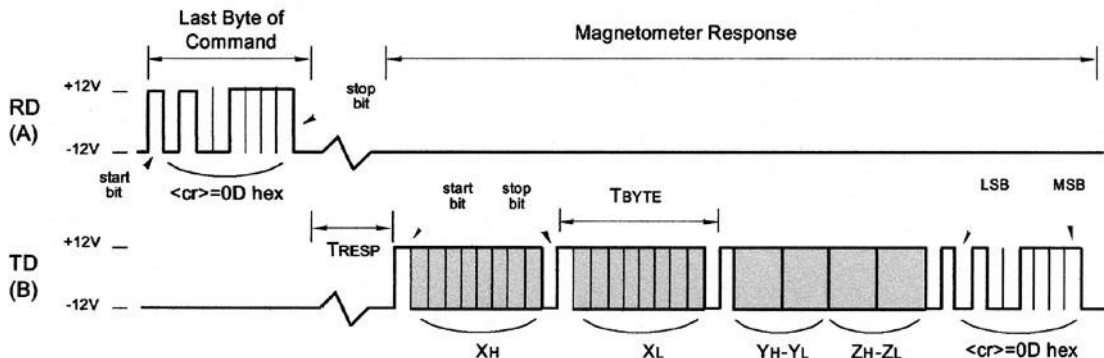

HMR2300

RS-485 COMMUNICATIONS (Timing is Not to Scale)

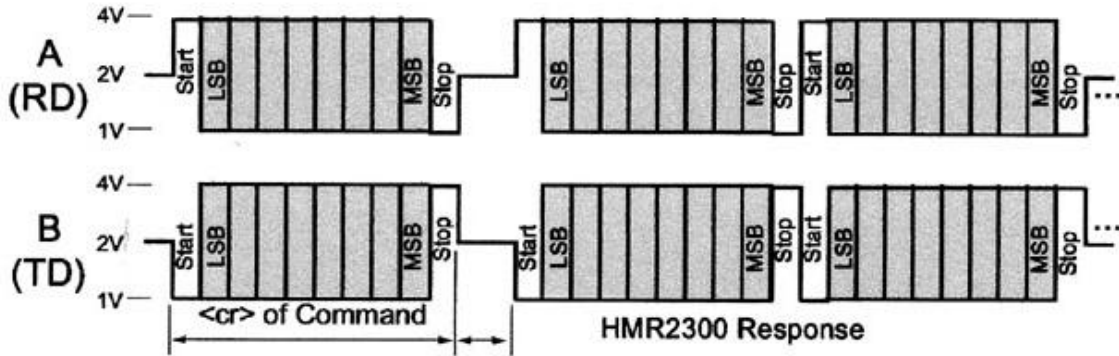

GLOBAL ADDRESS (*99) DELAY (Timing is Not to Scale)

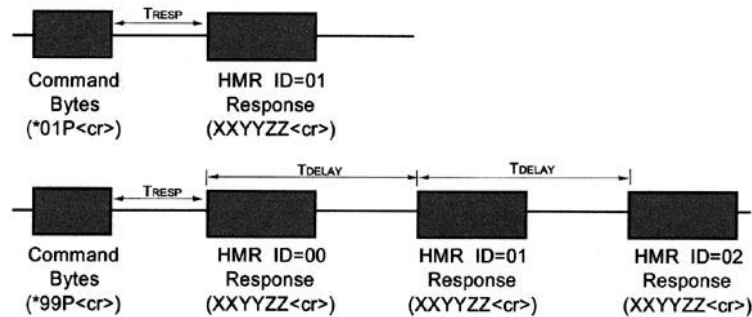

PIN CONFIGURATION

Pin Number	Pin Name	Description
1	NC	No Connection
2	TD	Transmit Data, RS-485 (B+)
3	RD	Receive Data, RS-485 (A-)
4	NC	No Connection
5	GND	Power and Signal Ground
6	NC	No User Connection (factory X offset strap +)
7	NC	No User Connection (factory Y offset strap +)
8	NC	No User Connection (factory Z offset strap +)
9	V+	Unregulated Power Input (+6 to +15 VDC)

PCB DIMENSIONS AND PINOUT (Connector Not Shown for Clarity)

