

General Specifications

ProSafe-RS Outline of I/O Modules



GS 32Q06K20-31E

[Release 3]

■ GENERAL

This GS describes the specifications of I/O modules to be mounted on the safety control unit or the safety node unit of the ProSafe-RS system.

An example of a system configuration is shown below.

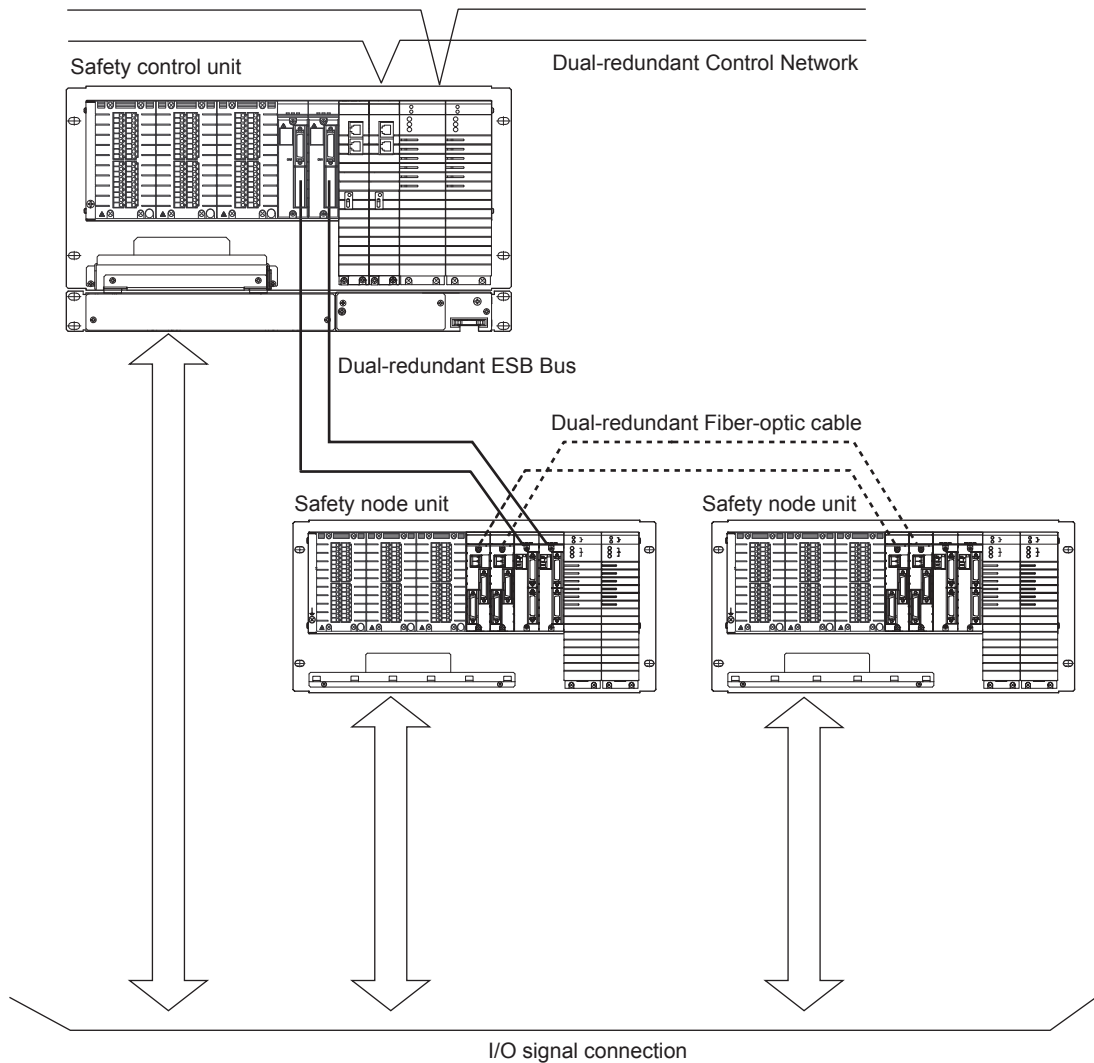

F01E.ai

Figure System Configuration

■ COMMON SPECIFICATIONS

● Installation Environment

Item		Specifications	
Temperature	Normal operation	-20 to 70 °C (*1)	(*2)
	Transportation/storage	-40 to 85 °C	
Humidity	Normal operation	5 to 95 % RH (non-condensing)	5 to 85 % RH when the SRM53D/SRM54D/SBM54D is mounted.
	Transportation/storage	5 to 95 % RH (non-condensing)	
Temperature change	During operation	Within ±10 °C/h	
	Transportation/storage	Within ±20 °C/h	
Power supply	Voltage range	100 to 120 V AC -15 %, +10 % 220 to 240 V AC -15 %, +10 % 24 V DC: -10 % to +20 %	
	Frequency	50/60 Hz ± 3 Hz	
	Distortion factor	10 % or less	
	Crest factor	100 V system: 118 V or larger 220 V system : 258 V or larger	
	Momentary failure	20 ms or less (when receiving the rated AC voltage)	
	DC power supply ripple rate	1 % p-p maximum	
Withstanding voltage		1500 V AC for 1 minute (for 100 to 120/220 to 240 V AC)	Between power & ground terminals
Insulation resistance		20 M ohms at 500 V DC	Between power & ground terminals
Grounding		Apply the grounding system which is defined by the rules and standards of the country or the region.	
Dust		Maximum of 0.3 mg/m ³	
Corrosive gas		ANSI/ISA S71.04 G3 (standard)	Excluding SRM53D/SRM54D/SBM54D
Noise	Electric field	10 V/m maximum (80 MHz to 1 GHz)	
	Static electricity	4 kV or less (direct discharge) 8 kV or less (aerial discharge)	
Vibration	Continuous vibration	Amplitude: 1.75 mm (5 Hz to 9 Hz) Acceleration: 4.9 m/s ² (9 Hz to 150 Hz)	
	Non-continuous vibration	Amplitude: 3.5 mm (5 Hz to 9 Hz) Acceleration: 9.8 m/s ² (9 Hz to 150 Hz)	
	Seismic	Acceleration: 4.9 m/s ² or less	
	Transportation	Horizontal: 4.9 m/s ² or less vertical: 9.8 m/s ² or less	when packaged
Impact		147 m/s ² or less, 11 ms	
Altitude		2000 m above sea level or less	

*1: 60 to 70 °C: Refer to "NODE UNIT MOUNTING RESTRICTIONS" section.

*2: When ALR111-S□1/ALR121-S□1 is installed, the ambient temperature should range from 0 to 60 °C. In case of ALR121-S□B, it should range from 0 to 70 °C.
When ALE111-S□1 is installed, the ambient temperature should range from 0 to 60 °C.

● ESB Bus

Application

ESB Bus is a communication bus that connects a safety control unit with a safety node unit.

Communication specifications

Up to 13 safety node units can be connected to ESB bus via SEC402 ESB bus coupler module on SSC60S/SSC60D safety control unit, and up to 9 safety node units to ESB bus via SEC401 ESB bus coupler module on SSC50S/SSC50D/SSC10S/SSC10D safety control unit.

Transmission route specifications

Network structure: bus

Transmission channel redundancy: dual-redundant

Network speed: 128 Mbits/second

Network cable: Dedicated communication cable (YCB301)

Transmission distance: 10 m maximum (*1)

- *1: Length of ESB buses must be 10 m or shorter each from upper and lower port of SEC402.

● Applicable Standards

Refer to "ProSafe-RS Safety Instrumented System Overview (GS 32Q01B10-31E, GS 32Q01B20-31E)."

■ STANDARD SPECIFICATIONS

● Safety Control Unit

A CPU module, two power supply modules, and two ESB Bus coupler modules, along with I/O modules, are mounted on the safety control unit.

There are 12 types of safety control units:

SSC60S-S: Safety control unit for Vnet/IP (standard (-20 to 40 °C) type)

SSC60S-F: Safety control unit for Vnet/IP (wide range temperature (-20 to 70 °C) type)

SSC60D-S: Duplexed safety control unit for Vnet/IP (standard (-20 to 40 °C) type)

SSC60D-F: Duplexed safety control unit for Vnet/IP (wide range temperature (-20 to 70 °C) type)

SSC50S-S: Safety control unit for Vnet/IP (standard (-20 to 40 °C) type)

SSC50S-F: Safety control unit for Vnet/IP (wide range temperature (-20 to 70 °C) type)

SSC50D-S: Duplexed safety control unit for Vnet/IP (standard (-20 to 40 °C) type)

SSC50D-F: Duplexed safety control unit for Vnet/IP (wide range temperature (-20 to 70 °C) type)

SSC10S-S: Safety control unit (standard (-20 to 50 °C) type)

SSC10S-F: Safety control unit (wide range temperature (-20 to 70 °C) type)

SSC10D-S: Duplexed safety control unit (standard (-20 to 50 °C) type)

SSC10D-F: Duplexed safety control unit (wide range temperature (-20 to 70 °C) type)

For more details, refer to Safety Control Unit (GS 32Q06D10-31E, GS 32Q06D20-31E and GS 32Q06D30-31E).

● Safety Node Unit

Two power supply modules, two ESB Bus interface modules, and I/O modules are mounted on the safety node unit.

SNB10D: Safety node unit (wide range temperature (-20 to 70 °C) type, Rack Mountable Type)

For more details, refer to Safety Node Unit (GS 32Q06K10-31E).

● Unit for Optical Bus Repeater Module

Optical ESB Bus Repeater Modules are installed in Unit for Optical Bus Repeater Module.

SNT10D: Unit for Optical Bus Repeater Module (Rack Mountable Type)

For details, refer to Unit for Optical Bus Repeater Module (GS 32Q06K11-31E).

● I/O Module

There are three types of I/O modules: an analog I/O module, a digital I/O module, and a communication module.

Table Mountability of I/O Module on Node Unit

Model	Module type	SSC60□ SSC50□ SSC10□	SNB10D	SNT10D	Redundancy	Temperature adaptability (*1) and G3 compatibility
–	Analog I/O modules					
SAI143	Analog input module (4 to 20 mA, 16-channel, module isolation)	X	X	–	X	X
SAV144	Analog input module (1 to 5 V/1 to 10 V, 16-channel, module isolation)	X	X	–	X	X
SAI533	Analog output module (4 to 20 mA, 8-channel, module isolation)	X	X	–	X	X
SAT145	TC/mV input module (16-channel, Isolated Channels)	X	X	–	X	X
SAR145	RTD input module (16-channel, Isolated Channels)	X	X	–	X	X
–	Digital I/O modules					
SDV144	Digital input module (16-channel, dry contact, module isolation) (*2)	X	X	–	X	X
SDV521	Digital output module (4-channel, 24 V DC/2 A, module isolation) (*3)	X	X	–	X	X
SDV526	Digital output module (4-channel, 100 to 120 V AC, module isolation)	X	X	–	X	X
SDV531	Digital output module (8-channel, 24 V DC, module isolation) (*3)	X	X	–	X	X
SDV53A	Digital output module (8-channel, 48 V DC, module isolation) (*3)	X	X	–	X	X
SDV541	Digital output module (16-channel, 24 V DC, module isolation) (*3)	X	X	–	X	X
–	Communication modules					
ALR111	Serial communications module (RS-232C) (*4)	X	X	–	X	G3 compatibility only
ALR121	Serial communications module (RS-422/RS-485) (*4)	X	X	–	X	X
ALE111	Ethernet communication module (*4) (*8)	X (*7)	X	–	X	G3 compatibility only
–	Bus interface modules					
SEC402	ESB bus coupler module (for SSC60□)	X (*5)	–	–	X (*6)	X
SEC401	ESB bus coupler module	X	–	–	X (*6)	X
SNT401	Optical ESB bus repeater master module	X	X	X	X (*6)	X
SNT501	Optical ESB bus repeater slave module	X	X	X	X (*6)	X
SNT411	Optical ESB bus repeater master module (for SSC60□/SSC50□)	X (*7)	X	X	X (*6)	X
SNT511	Optical ESB bus repeater slave module (for SSC60□/SSC50□)	X (*7)	X	X	X (*6)	X

X: Acceptable –: Not acceptable

*1: Temperature-adaptability is possible only when the I/O module is mounted on SSC□-F or SNB10D.

*2: Where a pulse test is enabled for field wiring diagnostic functions, diagnostic pulse (ON pulse) appears on the input channel periodically.

Pulse Interval: about 0.5 s, Pulse width: about 400 μs (style code S3) or about 200 μs (style code S1 and S2)

Use the devices that work appropriately even if there is the diagnostic pulse.

*3: Where a pulse test is enabled for field wiring diagnostic functions, diagnostic pulse (ON or OFF pulse) appears on the output channel periodically.

Pulse Interval: about 0.5 s, Pulse width: about 200 μs

Use the devices that work appropriately even if there is the diagnostic pulse.

*4: Interference-free module.

*5: Applicable to SSC60□ only

*6: Applicable to dual redundancy only.

*7: Applicable to SSC60□ and SSC50□.

*8: ALE111 style code S1 and unit revision U:2 or later must be used.

For more details on the I/O module specifications, refer to the I/O module specifications.

● Terminal Blocks

For wiring between an I/O module and field equipment, a signal cable interface adapter or a pressure clamp terminal block is available. MIL cables provided by the user may be used with a connector cover for MIL cable.

For a signal interface adapter, dedicated signal cable is used to connect with terminal board or relay board. There is option to prevent wrong type I/O module insertion. Option codes for this mechanism must be specified for I/O module and signal cables respectively. The I/O module and the signal interface adapter is the set purchase.

A pressure clamp terminal can be directly wired to field equipment. A signal cable interface adapter can be wired to field equipment via a terminal board.

There are two types of pressure clamp terminal blocks: a single configuration type and a dual-redundant configuration type. An I/O module can be made dual redundant on the terminal block.

An MIL cable can be directly connected to an I/O module without a terminal block. This cable is provided to customers by option. To prevent it from being disconnected from the I/O module, cable connector covers (SCCC01 and SCCC02) are available for the use with the MIL cable.

Table “Connection between I/O Module and Terminal Block” presents how an I/O module is connected with a terminal block and a connector cable.

Dedicated signal cable connection

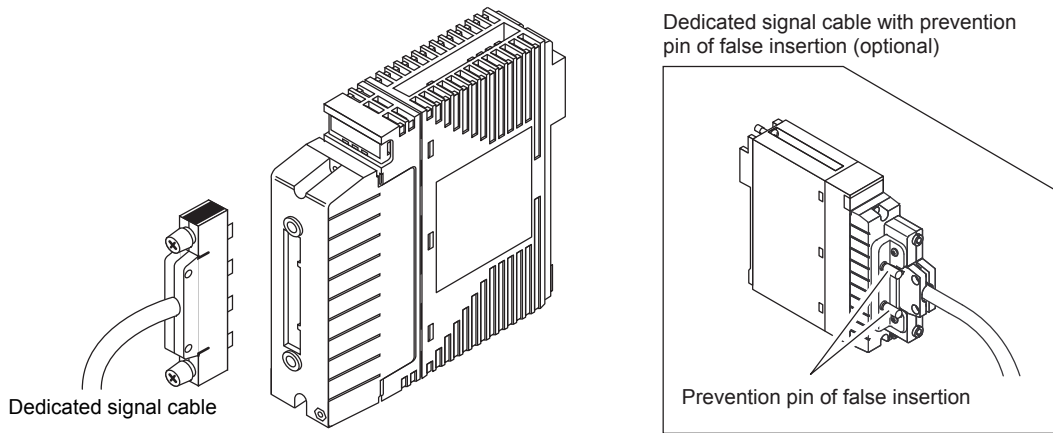

Pressure clamp terminal connection

Pressure clamp terminal block

I/O module

MIL cable connection

Connector cover for MIL cable

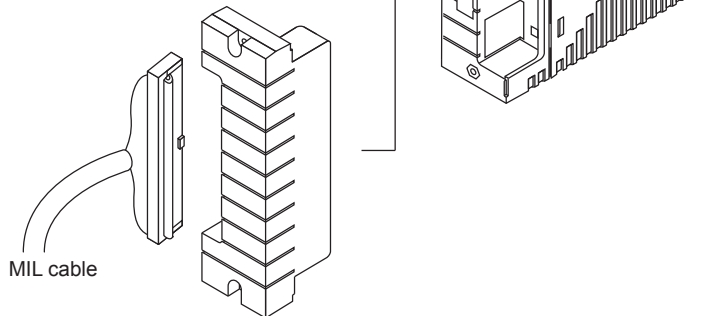

F02E.ai

Table I/O Module and Signal Connection

Model	Module type	Number of I/O points channels per module	Signal connection		
			Pressure clamp terminal	Dedicated cable (*1)	MIL cable
–	Analog I/O modules				
SAI143	Analog input module (4 to 20 mA, module isolation) (*2)	16	X	X	X
SAV144	Analog input module (1 to 5 V/ 1 to 10 V, module isolation) (*2)	16	X	X	X
SAI533	Analog output module (4 to 20 mA, module isolation) (*2)	8	X	X	X
SAT145	TC/mV input module (isolated channels)	16	–	X	–
SAR145	RTD input module (isolated channels)	16	–	X	–
–	Digital I/O modules				
SDV144	Digital input module (contact input, module isolation) (*2)	16	X	X	X
SDV521	Digital output module (24 V DC/2 A, module isolation) (*2)	4	–	X	–
SDV526	Digital output module (100 to 120 V AC, module isolation) (*2)	4	–	X	–
SDV531	Digital output module (24 V DC, module isolation) (*2)	8	X	X	X
SDV53A	Digital output module (48 V DC, module isolation) (*2)	8	–	X	–
SDV541	Digital output module (24 V DC, module isolation) (*2)	16	X	X	X
–	Communication modules				
ALR111	Serial communication module	2 ports	–	X (D-sub 9-pin) (*3)	–
ALR121	Serial communication module	2 ports	–	X (M4 terminal block 10-pole) (*3)	–
ALE111	Ethernet communication module	1 port	–	X (RJ-45) (*3)	–

X: Connectable –: Not connectable

*1: This cable for connecting I/O modules with terminal boards, and relay boards, is a Yokogawa Electric Corporation dedicated cable.

*2: Depending on the I/O module's connection configuration, there are restrictions regarding current, cable length, and the like.

*3: The dedicated signal cable can be connected directly to the I/O module without the terminal block.

Table Connection between I/O Module and Terminal Block

Model	Module type	Field wiring Connection connection means for field wiring					
		Pressure clamp terminal (pressure clamp terminal block)		Terminal board/Relay board, dedicated cable Upper : 19-inch Rack Mountable Type Lower : DIN Rail Mount Type		MIL cable	
		Single	Dual-redundant	Single	Dual-redundant	Single	Dual-redundant
SAI143	Analog input	STA4S	STA4D	SEA4D (1 port), KS1 (1 unit)	SEA4D (2 ports), KS1 (2 units)	MIL connector	MIL connector (2 units)
SBA4D (1 port), KS1 (1 unit)				SBA4D (2 ports), KS1 (2 units)			
SAV144	Analog output	STA4S	STA4D	SEA4D (1 port), KS1 (1 unit)	SEA4D (2 ports), KS1 (2 units)	MIL connector	MIL connector (2 units)
SBA4D (1 port), KS1 (1 unit)				SBA4D (2 ports), KS1 (2 units)			
SAI533	TC/mV input	—	—	—	—	—	—
SAT145				SBT4D (1 port), AKB331 (1 unit) (*2)	SBT4D (2 ports), AKB331 (2 units) (*2)		
SAR145	RTD input	—	—	—	—	—	—
SDV144				SBR4D (1 port), AKB611 (1 unit)	SBR4D (2 ports), AKB611 (2 units)		
SDV521	Digital input	STB4S	STB4D	SED4D/SRM53D (*1)/ SRM54D (1 port), AKB331 (1 unit) (*2)	SED4D/SRM53D (*1)/ SRM54D (2 ports), AKB331 (2 units) (*2)	MIL connector	MIL connector (2 units)
SDV526				SBD4D (1 port), AKB331 (1 unit) (*2)	SBD4D (2 ports), AKB331 (2 units) (*2)		
SDV531	Digital output	—	—	SED2D (1 port), AKB651 (1 unit) (*4)	SED2D (2 ports), AKB651 (2 units) (*4)	—	—
SDV53A				SBD2D (1 port), AKB651 (1 unit) (*4)	SBD2D (2 ports), AKB651 (2 units) (*4)		
SDV541 (*3)	—	—	—	SWD2D (1 port), AKB652 (1 unit)	SWD2D (2 ports), AKB652 (2 units)	—	—
SDV531				—	—		
SDV531	Digital output	STB4S	STB4D	SED4D/SRM53D (1 port), AKB331 (1 unit) (*2)	SED4D/SRM53D (2 ports), AKB331 (2 units) (*2)	MIL connector	MIL connector (2 units)
SDV53A				SBD3D (1 port), AKB331/AKB651 (1 unit) (*2) (*4) (*5)	SBD3D (2 ports), AKB331/AKB651 (2 units) (*2) (*4) (*5)		
SDV53A	—	—	—	SED3D (1 port), AKB331 (1 unit) (*2)	SED3D (2 ports), AKB331 (2 units) (*2)	—	—
SDV541 (*3)				SBD3D (1 port), AKB331/AKB651 (1 unit) (*2) (*4)	SBD3D (2 ports), AKB331/AKB651 (2 units) (*2) (*4)		
SDV541 (*3)	STB4S	STB4D	STB4D	SED4D/SRM54D (1 port), AKB331 (1 unit) (*2)	SED4D/SRM54D (2 ports), AKB331 (2 units) (*2)	MIL connector	MIL connector (2 units)
SDV541 (*3)				SBD4D/SBM54D (1 port), AKB331/AKB651 (1 unit) (*2) (*4)	SBD4D/SBM54D (2 ports), AKB331/AKB651 (2 units) (*2) (*4)		

Note: A dual-redundant terminal block is used for connecting two adjacent I/O modules.

Note: Cable connection covers (SCCC01 and SCCC02) are available for MIL connector connection.

*1: SDV144 to be connected with SRM53D or SRM54D is for relay read back.

*2: Use AKB331 style code S3 or later when connecting to SED3D, SBD3D or SBD4D.

*3: Use SDV541 style code S3 and firmware revision numbers F1:1 F2:1 or later when connecting to SBM54D.

*4: AKB651 can be used for connecting with SED2D, SBD2D, SBD3D or SBD4D.

*5: AKB651 can be used for connecting with SDV531-L only.

Table Connection between Communication Module, Bus Interface, and Communication Cable

Module type	Model	Communication cable
Communication module	ALR111	AKB131 AKB132 AKB135 AKB136 Other (prepared by customers)
	ALR121	AKB161 AKB162 Other (prepared by customers)
	ALE111	Ethernet Cable (*2) (prepared by customers)
Bus Interface	SNT401	Fiber-optic Cable (prepared by customers) (*1)
	SNT501	Fiber-optic Cable (prepared by customers) (*1)
	SNT411	Fiber-optic Cable (prepared by customers) (*1)
	SNT511	Fiber-optic Cable (prepared by customers) (*1)

*1: For a fiber-optic cable, refer to ProSafe-RS Safety Instrumented System Overview (GS 32Q01B10-31E, GS 32Q01B20-31E).

*2: Refer to Ethernet Communication Module (GS 32Q06K51-31E).

● Current Consumption of I/O Modules

Table Current Consumption of I/O Modules

Model	Module type	Maximum current consumption at 5 V DC (mA)	Maximum current consumption at 24 V DC (mA)
–	Analog I/O modules		
SAI143	Analog input module (16-channel, 4 to 20 mA, module isolation)	320	550
SAV144	Analog input module (16-channel, 1 to 5 V/ 1 to 10 V, module isolation)	300	140
SAI533	Analog output module (8-channel, 4 to 20 mA, module isolation)	320	300
SAT145	TC/mV input module (16-channel, isolated channels)	400	200
SAR145	RTD input module (16-channel, isolated channels)	500	200
–	Digital I/O modules		
SDV144	Digital input module (16-channel, contact input, module isolation)	290	140
SDV521	Digital output module (4-channel, 24 V DC/2 A, module isolation)	280	140
SDV526	Digital output module (4-channel, 100 to 120 V AC, module isolation)	500	50
SDV531	Digital output module (8-channel, 24 V DC, module isolation)	280	140
SDV53A	Digital output module (8-channel, 48 V DC, module isolation)	290	150
SDV541	Digital output module (24 V DC, 16-channel, module isolation)	300	150
–	Communication modules		
ALR111	Serial communication module (RS-232C, 2-port)	500	–
ALR121	Serial communication module (RS-422/RS-485, 2-port)	500	–
ALE111	Ethernet communication module (1-port)	500	–
–	Bus interface module		
SEC402	ESB bus coupler module	500	–
SEC401	ESB bus coupler module	500	–
SNT401	Optical ESB bus repeater master module	500	–
SNT501	Optical ESB bus repeater slave module	500	–
SNT411	Optical ESB bus repeater master module 5 km to 50 km (for SSC60□, SSC50□)	500	–
SNT511	Optical ESB bus repeater slave module 5 km to 50 km (for SSC60□, SSC50□)	500	–

■ NODE UNIT MOUNTING RESTRICTIONS (FOR AMBIENT TEMPERATURE 60 °C OR LOWER)

Power supply capacity limitation

Up to eight modules per unit can be mounted on SNB10D safety node unit and SSC60□/SSC50□/SSC10□ safety control unit; however, the number differs by power supply capacity. Use the Table “Coefficients of Module (temperature type)” to calculate the sum of Coefficient A and B, and figure out the number that both $\Sigma(\text{coefficient A}) + \Sigma(\text{coefficient B})$ and $\Sigma(\text{coefficient B})$ are satisfied within the value shown in the Table “Power Supply Capacity Limitation (temperature type, 60°C or lower)”. The values shown in the Table “Power Supply Capacity Limitation (temperature type, 60°C or lower)” differ by the installation environments such as for standard installation and explosion protection.

Table Coefficients of Module (temperature type)

Model	Coefficient A		Coefficient B	
	Single	Dual redundant	Single	Dual redundant
SAI143-H□3 (2-wire setting)	3	6	25	29
SAI143-H□3 (4-wire setting)	3	6	5	10
SAI143-S□3 (2-wire setting)	3	5	22	25
SAI143-S□3 (4-wire setting)	3	5	4	7
SAI533-H□3	3	6	12	23
SAV144-S□3	3	5	2	4
SAT145-S□3	5	8	8	16
SAR145-S□3	5	9	8	16
SDV144-S□3	2	4	2	4
SDV521-S□3	2	4	2	4
SDV526-S33	5	10	3	5
SDV531-L□3	2	4	2	4
SDV53A-S□3	2	4	3	5
SDV541-S□3	3	6	5	7
Other (*1)	5	10	0	0

*1: SEC401, SEC402, SNT401, SNT501, SNT411, SNT511, ALR111, ALR121, ALE111

Table Power Supply Capacity Limitation (temperature type, 60°C or lower)

Model	Installation environment	Ambient temperature (°C)	$\Sigma(\text{coefficient A}) + \Sigma(\text{coefficient B})$	$\Sigma(\text{coefficient B})$
SNB10D	Standard installations	$-20 \leq T_a \leq 60$	–	≤ 100
	For FM NI and Type n installation in Class I, Division 2/Zone 2 area:	$-20 \leq T_a \leq 50$	–	≤ 100
		$-20 \leq T_a \leq 60$	–	≤ 88
SSC60S SSC50S SSC10S	Standard installations	$-20 \leq T_a \leq 60$	≤ 121	≤ 85
	For FM NI and Type n installation in Class I, Division 2/Zone 2 area:	$-20 \leq T_a \leq 60$	≤ 121	≤ 85
		$-20 \leq T_a \leq 60$	≤ 97	≤ 85
SSC60D SSC50D SSC10D	Standard installations	$-20 \leq T_a \leq 60$	≤ 97	≤ 85
	For FM NI and Type n installation in Class I, Division 2/Zone 2 area:	$-20 \leq T_a \leq 60$	≤ 97	≤ 85
		$-20 \leq T_a \leq 60$	≤ 97	≤ 85

Example)

When the following I/O modules are mounted on SNB10D.
(Standard installation, ambient temperature 40°C)

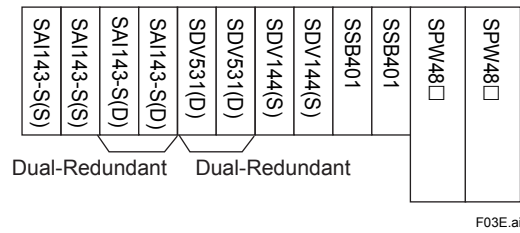

< Calculation method >

$$\begin{aligned} & \Sigma (\text{coefficient B}) \\ & = 22+22+25+4+2+2 \\ & = 77 (\text{mountable because } \leq 100 \text{ is satisfied}) \end{aligned}$$

Example)

When the following I/O modules are mounted on SSC10D.
(Standard installation, ambient temperature 40°C)

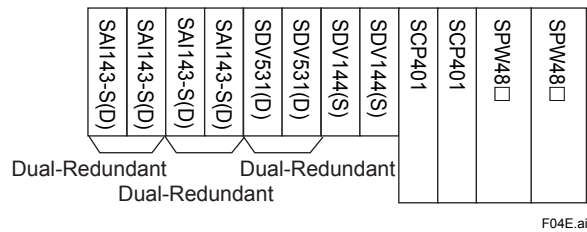

< Calculation method >

$$\begin{aligned} & \Sigma (\text{coefficient A}) + \Sigma (\text{coefficient B}) \\ & = (5+5+4+2+2) + (25+25+4+2+2) \\ & = 18+58 \\ & = 76 (\text{mountable because the sum of the coefficient A and the coefficient B } \leq 97 \text{ and the coefficient B } \leq 85 \text{ are satisfied}) \end{aligned}$$

Channel availability maximum load current, and external power supply voltage

No specific conditions. Also refer to the I/O module specifications.

Mounting rules

No specific conditions.

■ NODE UNIT MOUNTING RESTRICTIONS (FOR AMBIENT TEMPERATURE MORE THAN 60 °C)

When SNB10D safety node unit and SSC60□-F /SSC50□-F/SSC10□-F safety control unit for wide range temperature type are used in the ambient temperature of more than 60 °C, available channel of I/O module, maximum load current, external power supply voltage, and mounting location are also restricted as shown below, in addition to the power supply capacity.

There are two types I/O module available - "ISA Standard G3 and temperature" type and "ISA Standard G3 and high-density installation" type. For example, the maximum of eight modules can be mounted on a safety node unit for ISA Standard G3 and high-density installation type and four for ISA Standard G3 and temperature type per unit. ISA Standard G3 and high-density installation type improves the installation efficiency.

● For ISA Standard G3 and High-density Installation Type

By selecting the ISA Standard G3 and high-density installation type listed on the Table "Coefficients of Module (high-density installation type)", I/O module can be installed side by side without leaving an empty slot. SAI143-S□3, SAI533-H□3 and ALR121-S□B allow usages of ISA Standard G3 and temperature type in the same situation as ISA Standard G3 and high-density installation type. Do not mixedly install I/O modules other than listed on the Table "Coefficients of Module (high-density installation type)" on the same node unit. If different types of modules are mounted together, apply the installation conditions of the ISA Standard G3 and temperature type.

Power supply capacity limitation

When ISA Standard G3 and high-density installation type is used at the ambient temperature of more than 60 °C, make sure that Σ (coefficient A) + Σ (coefficient B), Σ (coefficient A) and Σ (coefficient B) must fall within the value shown on the Table "Power Supply Capacity Limitation (high-density installation type)".

Table Coefficients of Module (high-density installation type)

Model	Coefficient A		Coefficient B	
	Single	Dual redundant	Single	Dual redundant
SAI143-H□C (2-wire setting)	3	6	25	29
SAI143-H□C (4-wire setting)	3	6	5	10
SAI143-S□3 (*1) (2-wire setting)	3	5	22	25
SAI143-S□3 (*1) (4-wire setting)	3	5	4	7
SAI533-H□3 (*1)	3	6	12	23
SDV144-S□C	2	4	2	4
SDV521-S□C	2	4	2	4
SDV531-L□C	2	4	2	4
SDV541-S□C	3	6	5	7
ALR121-S□B (*1)	5	10	0	0
Other (*2)	5	10	0	0

*1: The usage of ISA Standard G3 and temperature type is allowed in the same situation as ISA Standard G3 and high-density installation type.

*2: SEC401, SEC402

Table Power Supply Capacity Limitation (high-density installation type)

Model	Installation environment	Ambient temperature	$\Sigma(\text{coefficient A}) + \Sigma(\text{coefficient B})$	$\Sigma(\text{coefficient A})$	$\Sigma(\text{coefficient B})$
SNB10D	Standard installations	$-20 \leq Ta \leq 65$	≤ 112	–	≤ 84
		$-20 \leq Ta \leq 70$	≤ 102	–	≤ 80
	For FM NI and Type n installation in Class I, Division 2/Zone 2 area:	$-20 \leq Ta \leq 65$	≤ 112	–	≤ 84
		$-20 \leq Ta \leq 70$	≤ 102	–	≤ 80
SSC60S SSC50S	Standard installations	$-20 \leq Ta \leq 65$	–	≤ 40	≤ 68
		$-20 \leq Ta \leq 70$	–	≤ 40	≤ 61
	For FM NI and Type n installation in Class I, Division 2/Zone 2 area:	$-20 \leq Ta \leq 65$	–	≤ 40	≤ 68
		$-20 \leq Ta \leq 70$	–	≤ 40	≤ 61
SSC60D SSC50D	Standard installations	$-20 \leq Ta \leq 65$	–	≤ 25	≤ 68
		$-20 \leq Ta \leq 70$	–	≤ 25	≤ 61
	For FM NI and Type n installation in Class I, Division 2/Zone 2 area:	$-20 \leq Ta \leq 65$	–	≤ 25	≤ 68
		$-20 \leq Ta \leq 70$	–	≤ 25	≤ 61

Channel availability, maximum load current, and external power supply voltage

When ISA Standard G3 and high-density installation type is used at the ambient temperature of more than 60 °C, the channel availability, maximum load current, and external power supply voltage are restricted as in the tables below.

•SAI143-H□C

Model	Ambient temperature	Channel Numbers															
		1	2	3	4	5	6	7	8	9	10	11	12	13	14	15	16
SAI143-H□C 2-wired setting	$-20 \text{ °C} \leq Ta \leq 65 \text{ °C}$	X	X	X	X	X	X	X	X	X	X	X	X	X	X	–	–
	$-20 \text{ °C} \leq Ta \leq 70 \text{ °C}$	X	X	X	X	X	X	X	X	–	–	–	–	–	–	–	–
SAI143-H□C 4-wired setting	$-20 \text{ °C} \leq Ta \leq 65 \text{ °C}$	X	X	X	X	X	X	X	X	X	X	X	X	X	X	X	X
	$-20 \text{ °C} \leq Ta \leq 70 \text{ °C}$	X	X	X	X	X	X	X	X	X	X	X	X	–	–	–	–

X: Connectable –: Not connectable

•SAI143-S□3

Model	Ambient temperature	Channel Numbers															
		1	2	3	4	5	6	7	8	9	10	11	12	13	14	15	16
SAI143-S□3 2-wired setting	$-20 \text{ °C} \leq Ta \leq 65 \text{ °C}$	X	X	X	X	X	X	X	X	X	X	X	X	X	X	–	–
	$-20 \text{ °C} \leq Ta \leq 70 \text{ °C}$	X	X	X	X	X	X	X	X	X	X	–	–	–	–	–	–
SAI143-S□3 4-wired setting	$-20 \text{ °C} \leq Ta \leq 70 \text{ °C}$	X	X	X	X	X	X	X	X	X	X	X	X	X	X	X	X

X: Connectable –: Not connectable

Note: The usage of ISA Standard G3 and temperature type is allowed in the same situation as ISA Standard G3 and high-density installation type. When the ambient temperature is 60 °C or lower, all channels are connectable.

•SAI533-H□3

Model	Ambient temperature	Channel Numbers							
		1	2	3	4	5	6	7	8
SAI533-H□3	$-20 \text{ °C} \leq Ta \leq 65 \text{ °C}$	X	X	X	X	X	X	–	–
	$-20 \text{ °C} \leq Ta \leq 70 \text{ °C}$	X	X	X	X	–	–	–	–

X: Connectable –: Not connectable

Note: The usage of ISA Standard G3 and temperature type is allowed in the same situation as ISA Standard G3 and high-density installation type. When the ambient temperature is 60 °C or lower, all channels are connectable.

•SDV144-S□□

Model	Ambient temperature	Channel Numbers																24 V DC External power supply
		1	2	3	4	5	6	7	8	9	10	11	12	13	14	15	16	
SDV144-S□□	-20 °C ≤ Ta ≤ 65 °C	X	X	X	X	X	X	X	X	X	X	X	X	X	X	X	X	+10%, -10%
	-20 °C ≤ Ta ≤ 70 °C	X	X	X	X	X	X	X	X	X	X	X	X	-	-	-	-	

X: Connectable -: Not connectable

•SDV521-S□□

Model (Maximum load current)	Ambient temperature	Channel Numbers				24 V DC External power supply
		1	2	3	4	
SDV521-S□□ (2 A/CH)	-20 °C ≤ Ta ≤ 65 °C	X	X	X	-	+20%, -10%
	-20 °C ≤ Ta ≤ 70 °C	-	-	-	-	
SDV521-S□□ (1.5 A/CH)	-20 °C ≤ Ta ≤ 65 °C	X	X	X	X	
	-20 °C ≤ Ta ≤ 70 °C	X	X	-	-	
SDV521-S□□ (1 A/CH)	-20 °C ≤ Ta ≤ 70 °C	X	X	X	X	

X: Connectable -: Not connectable

•SDV531-L□□

Model (Maximum load current)	Ambient temperature	Channel Numbers								24 V DC External power supply
		1	2	3	4	5	6	7	8	
SDV531-L□□ (0.6 A/CH)	-20 °C ≤ Ta ≤ 65 °C	X	X	X	X	X	X	-	-	+20%, -10%
	-20 °C ≤ Ta ≤ 70 °C	X	X	X	X	-	-	-	-	
SDV531-L□□ (0.45 A/CH)	-20 °C ≤ Ta ≤ 65 °C	X	X	X	X	X	X	X	X	
	-20 °C ≤ Ta ≤ 70 °C	X	X	X	X	-	-	-	-	
SDV531-L□□ (0.4 A/CH)	-20 °C ≤ Ta ≤ 70 °C	X	X	X	X	X	X	X	X	

X: Connectable -: Not connectable

•SDV541-S□□

Model (Maximum load current)	Ambient temperature	Channel Numbers																24 V DC External power supply
		1	2	3	4	5	6	7	8	9	10	11	12	13	14	15	16	
SDV541-S□□ (0.2 A/CH)	-20 °C ≤ Ta ≤ 65 °C	X	X	X	X	X	X	X	X	X	X	X	X	-	-	-	-	+20%, -10%
	-20 °C ≤ Ta ≤ 70 °C	X	X	X	X	X	X	X	X	X	X	-	-	-	-	-	-	
SDV541-S□□ (0.15 A/CH)	-20 °C ≤ Ta ≤ 70 °C	X	X	X	X	X	X	X	X	X	X	X	X	X	X	X	X	

X: Connectable -: Not connectable

Mounting rules

Modules can be mounted on Slots No. 1 to 8 of SNB10D Safety Node Unit.

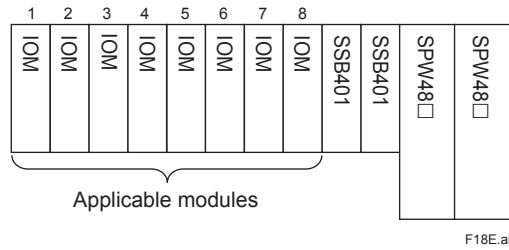

Figure Mounting examples on a safety node unit

Modules can be mounted on the slots No. 1 to 7 of SSC60-F and SSC50-F Safety Control Unit where ESB bus coupler module is not mounted.

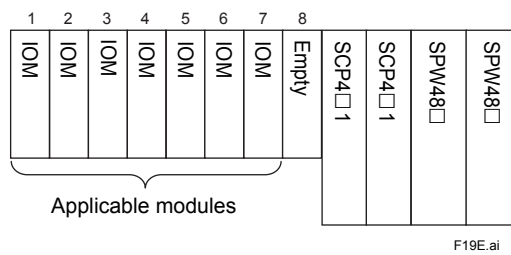

Figure Mounting examples of a safety control unit (without ESB bus coupler)

Modules can be mounted on the slots No. 1 to 6 of SSC60-F and SSC50-F Safety Control Unit with ESB bus coupler.

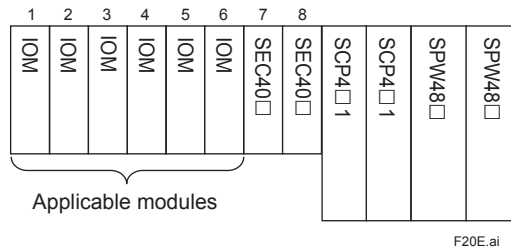

Figure Mounting examples of a safety control unit (with ESB bus coupler)

When mounting I/O modules (ISA Standard G3 and high-density installation type) to a Safety Node Unit or a Safety Control unit at the ambient temperature more than 60 °C, mount them in order of DIO (Digital Input/Output module) → AI (Analog Input module) → AO (Analog Output module) from left to right. (Example 1)

In Addition, the following conditions must be met:

- AI cannot be mounted on the immediate right slot of AO. (Example 2)
(When an empty slot or communication module such as ALR is inserted between AO and AI, the order of the modules is acceptable.) (Example 3)
- DIO cannot be mounted on the immediate right slot of AI or AO. (Example 4)
(When an empty slot or communication module such as ALR is inserted between AI and DIO, or between AO and DIO, the order of the modules is acceptable.) (Example 5)

See the following examples.

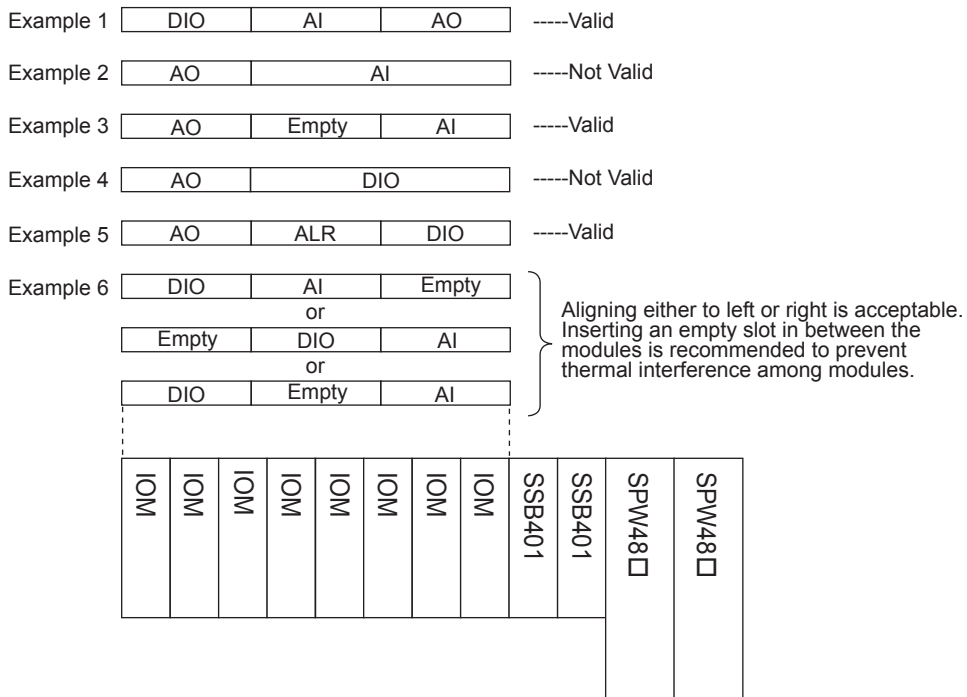

F21E.ai

Figure Examples of SNB10D

● **For ISA Standard G3 and Temperature Type**

When using I/O modules other than the ones listed on the Table “Coefficients of Module (high-density installation type)”, select ISA Standard G3 and temperature type which meets the following conditions.

Power supply capacity limitation

Refer to the Table “Coefficients of Module (temperature type)” to find the sum of Coefficient A and B assigned to the module and then make sure that Σ (coefficient A) + Σ (coefficient B) and Σ (coefficient B) satisfy the value on the Table “Power Supply Capacity Limitation (temperature type, more than 60°C)”.

Table Power Supply Capacity Limitation (temperature type, more than 60°C)

Model	Installation environment	Ambient temperature (°C)	Σ (coefficient A) + Σ (coefficient B)	Σ (coefficient B)
SNB10D	Standard installations	-20 ≤ Ta ≤ 70	–	≤ 100
	For FM NI and Type n installation in Class I, Division 2/Zone 2 area:	-20 ≤ Ta ≤ 70	–	≤ 80
SSC60S SSC50S SSC10S	Standard installations	-20 ≤ Ta ≤ 70	≤ 121	≤ 85
	For FM NI and Type n installation in Class I, Division 2/Zone 2 area:	-20 ≤ Ta ≤ 70	≤ 121	≤ 80
SSC60D SSC50D SSC10D	Standard installations	-20 ≤ Ta ≤ 70	≤ 97	≤ 85
	For FM NI and Type n installation in Class I, Division 2/Zone 2 area:	-20 ≤ Ta ≤ 70	≤ 97	≤ 80

Channel availability, maximum load current, and external power supply voltage

No specific conditions. Also refer to the I/O module specifications.

Mounting rules

When using SNB10D safety node unit or SSC60□-F/SSC50□-F/SSC10□-F wide range temperature type of safety control unit at the ambient temperature more than 60°C, the following rules must be met:

- The maximum of four I/O modules per unit can be mounted. However, it of the safety control unit becomes three per unit when the safety node is extended with SSC60□-F, SSC50□-F or SSC10□-F, because SEC40□ are mounted on slots 7 and 8.
- Leave at least one slot empty in between an I/O module and SEC40□, SNT□□1, SSB401, and SCP4□1.
- Leave at least one slot empty between I/O modules.
Leave the slots annexed to the dual-redundant modules empty.
- As for SNT□□1, leave two slots empty for every dual-redundant module between the modules such as SEC40□, SNT□□1, SSB401, and SPW48□.

At least one empty slot is required between SSB401 and I/O module

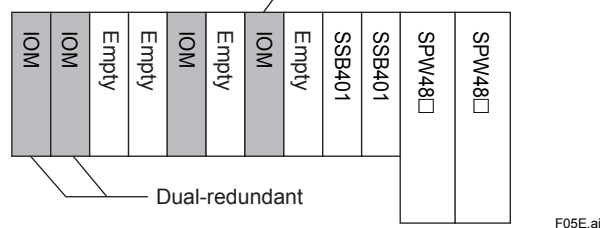

Figure Example Mounting of I/O Module on Safety Node Unit

■ **NODE UNIT MOUNTING RESTRICTIONS (MISCELLANEOUS)**

● **For ALR111, ALR121 and ALE111**

The maximum number of ALR111, ALR121 and ALE111 modules mountable:

6 modules per SCS (4 units for master (ALR111 and ALR121), 2 units for slave (ALR111, ALR121 and ALE111))

● **For SEC402 and SEC401**

SEC402 or SEC401 can be mounted on slots No. 7 and 8 of the safety control unit.

■ CAUTIONS FOR MOUNTING

● Terminal board and relay board mounting directions

Mount a terminal board and a relay board in the directions as shown in the below figure.

When mounting SBD2D in the direction of b or c, the following conditions must be met.

- When the ambient temperature is 60 °C or lower, the total load current of the SBD2D must be kept within the specified value of 8 A or lower.
- When the ambient temperature is at 70 °C, the total load current must be 6 A or less.
- In case the ambient temperature is in between 60 and 70 °C, reduce the total load current from 8 A maximum by the rate of 0.2 A/°C.

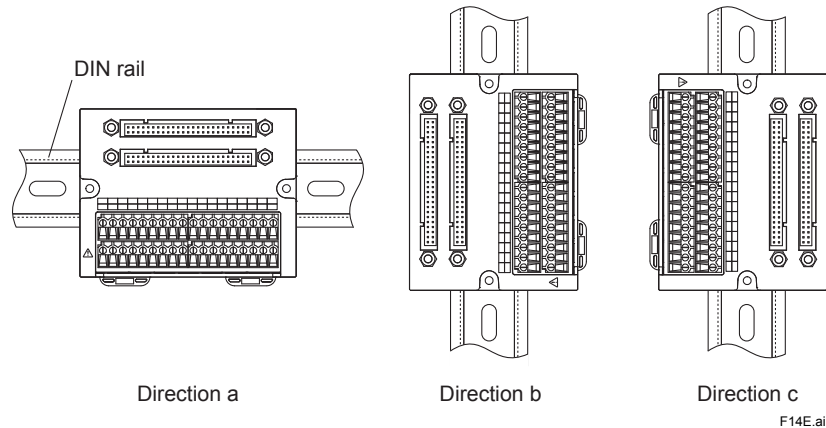

● Mounting an SAT145 module with SBT4D terminal board

Prevent the terminal board from being influenced by the ambient temperature in order to keep the reference junction compensation accuracy, as detailed conditions are shown below.

The reference junction compensation accuracy is specified when the ambient temperature is stable. When the temperature fluctuates, the accuracy may vary until it becomes stable.

Mounting a terminal board by itself

Install all the heat sources above the terminal board or terminal board wiring. Provide a heat shield in case installation of the heat sources below or sideways of the terminal board is unavoidable.

Installing terminal board in a cabinet

Install all the heat sources above the terminal board or terminal board wiring when those are mounted in a cabinet.

Provide a heat shield in case installation of the heat sources below or sideways of the terminal board is unavoidable.

● Cautions of the power source for the loads of SBM54D

In the case of using multiple power sources for the loads of SBM54D, there are cautions of the load voltage. When the load voltage is different between loads.

All of the load voltages must be in either the range below.

- Load voltages ≤ 100 V
- 50 V < Load voltages ≤ 150 V

● Cautions of the Digital I/O module when SBM54D is used.

The functions of Disconnection diagnosis, ON Pulse diagnosis and OFF Pulse diagnosis for SDV541 must be disabled when SBM54D is used.

● **Mounting I/O Modules for Dual Redundancy**

For dual redundancy, I/O modules should be mounted on Slot No. IO1-IO2, IO3-IO4, IO5-IO6, or IO7-IO8, as shown in the figure below.

Slot number	IO1	IO2	IO3	IO4	IO5	IO6	IO7	IO8	C1	C2	P1	P2
	IOM	IOM	IOM	IOM	IOM	IOM	IOM	IOM	SCP451 or SCP401	SCP451 or SCP401	SPW481 or SPW482 or SPW484	SPW481 or SPW482 or SPW484

F07E.ai

For the Safety Control Unit

Slot number	IO1	IO2	IO3	IO4	IO5	IO6	IO7	IO8	B1	B2	P1	P2
	IOM	IOM	IOM	IOM	IOM	IOM	IOM	IOM	SSB401	SSB401	SPW481 or SPW482 or SPW484	SPW481 or SPW482 or SPW484

F06E.ai

For the Safety Node Unit

● **Empty Slot Protection**

Be sure to mount a dummy cover (SDCV01) on an empty slot on which an I/O module is not mounted.

■ LIMITATIONS ON DIGITAL INPUT MODULE CONNECTIONS

Digital input incorporates input wiring diagnostic functions. Where a pulse test is enabled, it is necessary to take into account the following conditions for the length of the field wiring cable.

● If Pulse Test is Used

The total value of the capacitance of the field devices connected to the digital input modules and their wiring cable capacitance should be:

$$\text{Total capacitance} < 0.1 \mu\text{F} \text{ (100000 pF)}$$

Note: Wiring capacitance from pressure clamp terminal block or terminal board to the field device depends on the cable type such as Discrete wire or Multi-core cable. Make sure the specification of cable.

Note: Calculate the total capacitance of an AKB331 cable with a capacitance of 60 pF/m.

Note: It is not necessary to take into account the capacitance of pressure clamp terminal block, terminal boards, or signal cable adapters.

[References]

For terminal board connections, if the AKB331 cable is 15 m long, the distance between the terminal board and field device is 500 m, the capacitance of the cables is 100 pF/m, and the capacitance of the field devices is 0 pF then

$$\begin{aligned} \text{the total wiring capacitance} &= 15 \text{ (m)} \times 60 \text{ (pF/m)} + 500 \text{ (m)} \times 100 \text{ (pF/m)} + 0 \text{ (pF)} \\ &= 50900 \text{ (pF)} < 100000 \text{ (pF)} \end{aligned}$$

From this calculation, pulse test can work properly.

● If SCB110 Wiring Check Adapters are Used

To get digital input modules to recognize an ON input signal correctly, the total resistance of field devices and their wiring cables is no greater than 132 Ω.

If no SCB110 wiring check adapters are used, the cables connecting the digital input module and the field devices should be limited in length so that the total resistance of all the connected field devices and cables is no greater than 1 kΩ.

Note: It is not necessary to take into account the resistance of pressure clamp terminals, terminal boards, signal cable adapters, and wiring check adapters (SCB100/SCB110).

The following table shows AKB331 cable lengths and allowable resistance on the field side if AKB331 cables are used.

AKB331 cable length, m	Resistance allowed on the field side, Ω
0	132
10	120
20	109
30	98
40	87
50	75

[References]

For example, if the AKB331 cable length is 10 meters and the resistance of field device ON is 20 Ω, the allowable wiring resistance is then:

$$120 \Omega - 20 \Omega = 100 \Omega$$

The cable length, both from and to field devices if the cables have a wiring resistance of 58 Ω/km (AWG22 equivalent), is:

$$100 \Omega / 0.058 \Omega/\text{m} \approx 1724 \text{ (m)}$$

Hence, the distance to the field devices is:

$$1724 \text{ (m)} / 2 = 862 \text{ (m)}$$

Note: For cable resistances, refer to the cable manufacturer's specifications.

■ LIMITATIONS ON DIGITAL OUTPUT MODULE CONNECTIONS

Digital output modules incorporate output wiring diagnostic functions. Where a pulse test is enabled, it is necessary to take into account the following conditions for the length of the field wiring cable.

The total value of the capacitance of the field devices connected to the digital input and output modules and their wiring cable capacitance should be:

Total capacitance < 0.1 μ F (100000 pF)

Note: Wiring capacitance from pressure clamp terminal block or terminal board to the field device depends on the cable type such as Discrete wire or Multi-core cable. Make sure the specification of cable.

Note: Calculate the total capacitance of an AKB331 cable with a capacitance of 60 pF/m.

Note: Calculate the total capacitance of an AKB651 cable with a capacitance of 200 pF/m.

Note: It is not necessary to take into account the capacitance of pressure clamp terminal block, terminal boards, or signal cable adapters.

[References]

For terminal board connections, if the AKB331 cable is 15 m long, the distance between the terminal board and field device is 500 m, the capacitance of the cables is 100 pF/m, and the capacitance of the field devices is 0 pF then

$$\begin{aligned} \text{the total wiring capacitance} &= 15 \text{ (m)} \times 60 \text{ (pF/m)} + 500 \text{ (m)} \times 100 \text{ (pF/m)} + 0 \text{ (pF)} \\ &= 50900 \text{ (pF)} < 100000 \text{ (pF)} \end{aligned}$$

From this calculation, pulse test can work properly.

When digital output modules are connected with terminal boards, MIL connectors or pressure clamp terminals, due to the voltage drop on the field wirings, the length of field wirings have restrictions as follows.

● SDV531

Terminal Board is Connected

The SDV531 digital output module can respectively handle a maximum of 0.6 A load currents per channel. However, this can cause the generation of a voltage drop due to connected cable and adapter resistance components, etc. Therefore, it is necessary to take account of the limitations on the magnitude of load current and connected cable length as given below.

In case of short circuits detection is enabled, the possible cable length may be limited.

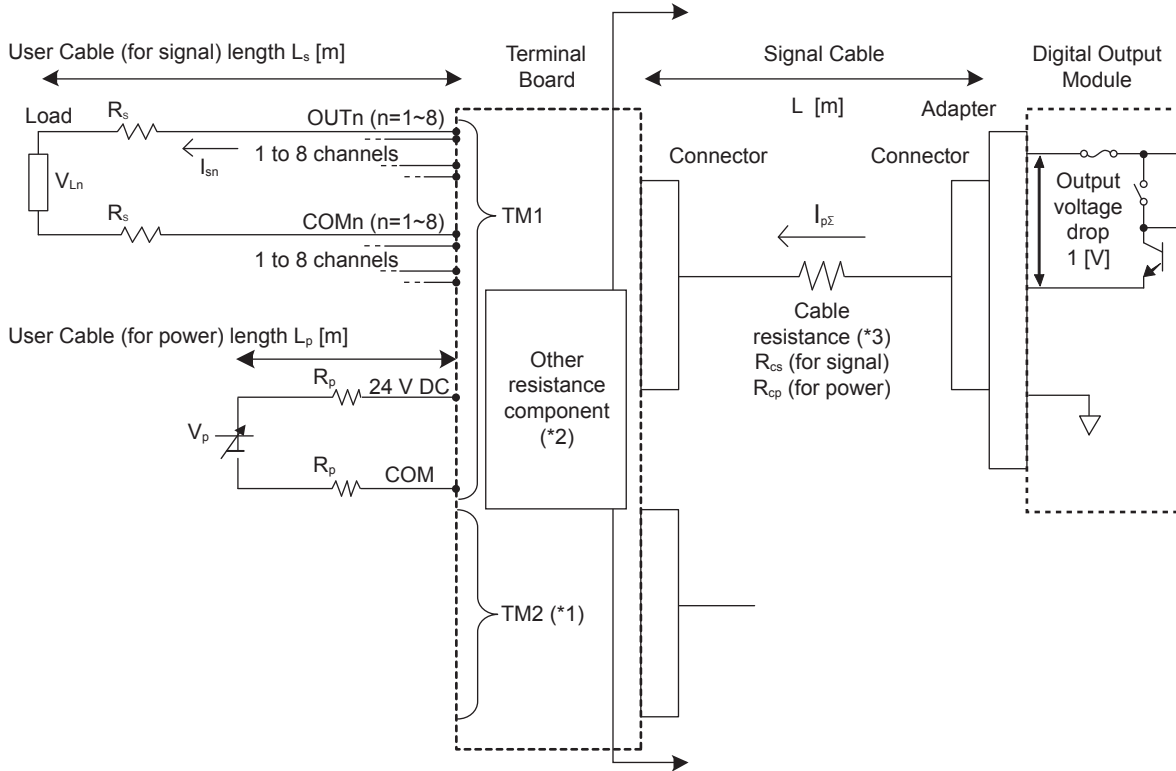

F11E.ai

*1: TM1 only for SBD3D

*2: Other resistance component is given below:

Table Other resistance component vs. Terminal board

Terminal board model No.	Connection module model No.	Other resistance component [mΩ] (By 1 channel)	
		Signal	Power
SED4D	SDV531	202.8	56.36
SBD3D	SDV531	222.1	34.72

*3: Cable resistance is given below:

Table Signal cable vs. Cable resistance

Signal cable model No.	Cable resistance [mΩ/m]	
	R _{cs} (for signal)	R _{cp} (for power)
AKB331	446.0	63.71
AKB651	118.6	16.94

If the digital output module connection is configured with a terminal board, signal cable, and adapter for signal cable, observe the following preconditions:

- the external power supply voltage is expressed as V_p [V],
- user cable (power) length as L_p [m],
- user cable (power) resistance value as R_p [Ω /m],
- user cable (signal) length as L_s [m],
- user cable (signal) resistance value as R_s [Ω /m],
- signal cable length as L [m],
- signal cable (signal) resistance value as R_{cs} [Ω /m],
- signal cable (power) resistance value as R_{cp} [Ω /m],
- total value of current flowing through channel 1 to channel 8 as $I_{p\Sigma}$ [A],
- current flowing through n-channel as I_{sn} [A] and
- voltage supplied to loads connected to n-channel as V_{Ln} [V].

For SED4D

The voltage drop from the external power supply (V_p) to the output channel load is a total voltage drop of $\Delta V1$ in the power line, $\Delta V2$ in the signal line and $\Delta V3$ in the circuit inside Digital Output Module. Therefore, the voltage supplied to the load connected to a channel is expressed by:

$$V_{Ln} = V_p - (\Delta V1 + \Delta V2 + \Delta V3)$$

$$= V_p - (R_p \times L_p \times 2 + R_{cp} \times L + 0.05636) \times I_{p\Sigma} - (R_s \times L_s \times 2 + R_{cs} \times L + 0.2028) \times I_{sn} - 1$$

[References]

The following shows a possible user signal cable length L_s [m] when changing the length, L [m], of a AKB331 signal cable and the current, I_{sn} [A], flowing through n-channel as in the table below.

Other parameters are given below:

- L_p [m] 0.5 User cable (power) length
- R_p [Ω /m] 0.0096 User cable (power) resistance value (when using AWG14)
- R_s [Ω /m] 0.0096 User cable (signal) resistance value (when using AWG14)
- V_{Ln} [V] 21.6 Voltage supplied to loads connected to n-channel
- $I_{p\Sigma}$ [A] ($I_{sn} \times 8$) Total value of current flowing through channel 1 to channel 8
- The capacitance of an AKB331 cable 60 [pF/m]

Wiring capacitance of User cable is calculated with the parameters given below:

- User cable (signal) wiring capacitance 50 [pF/m]
- Field devices capacitance 0 [pF]

- In case the external power supply voltage (V_p [V]) is 28.8 V.

Table Possible Cable Length, L_s [m], (when Using AWG14) from the Terminal Board to Loads

Current value (I_{sn}) per channel, [A]	AKB331 cable length							
	15 m	10 m	7 m	5 m	3 m	2 m	1 m	0.6 m
0.1	415.0	555.0	639.0	695.0	751.0	779.0	807.0	818.2
0.2	391.8	539.0	627.4	686.3	745.2	774.6	804.1	815.8
0.3	291.7	523.0	615.7	677.5	739.3	770.2	801.1	813.5
0.4	22.6	271.5	420.8	520.4	619.9	669.7	719.5	739.4
0.5	Not applicable	110.0	259.4	358.9	458.5	508.2	558.0	577.9
0.6	Not applicable	2.4	151.7	251.3	350.8	400.6	450.4	470.3

Note: In addition to the influence of voltage drop and wiring capacitance, possible cable length may be shorter when the short circuit detection during output OFF is needed. The above table shows the case that short circuit detection is taken into account. Columns grey in the above table are the area influenced by the short circuit detection.

For SBD3D

SBD3D has parallel diode inside in order to use dual-redundant configuration power supply.

The voltage drop of this diode shows 0.55 V. An external power supply shall be specified as additional 0.55 V within the applicable voltage range 28.8 V maximum of the SBD3D.

The voltage drop from the external power supply (V_p) to the output channel load is a total voltage drop of $\Delta V1$ in the power line, $\Delta V2$ in the signal line and $\Delta V3$ in the circuit inside Digital Output Module. Therefore, the voltage supplied to the load connected to a channel is expressed by:

$$V_{Ln} = V_p - (\Delta V1 + \Delta V2 + \Delta V3) \\ = V_p - (R_p \times L_p \times 2 + R_{cp} \times L + 0.03472) \times I_{p\Sigma} - 0.55 - (R_s \times L_s \times 2 + R_{cs} \times L + 0.22212) \times I_{sn} - 1$$

[References]

The following shows a possible user signal cable length L_s [m] when changing the length, L [m], of a signal cable and the current, I_{sn} [A], flowing through n-channel as in the table below.

Other parameters are given below:

L_p [m]	0.5	User cable (power) length
R_p [Ω /m]	0.00798	User cable (power) resistance value (when using 2.5 mm ²)
R_s [Ω /m]	0.00798	User cable (signal) resistance value (when using 2.5 mm ²)
V_{Ln} [V]	21.6	Voltage supplied to loads connected to n-channel
$I_{p\Sigma}$ [A]	($I_{sn} \times 8$)	Total value of current flowing through channel 1 to channel 8
The capacitance of an AKB331 cable	60 [pF/m]	
The capacitance of an AKB651 cable	200 [pF/m]	

Wiring capacitance of User cable is calculated with the parameters given below:

User cable (signal) wiring capacitance	50 [pF/m]
Field devices capacitance	0 [pF]

- In case AKB331 cable is used at the external power supply voltage (V_p [V]) of 28.8 V.

Table Possible cable Length, L_s [m], (when Using 2.5 mm²) from the Terminal Board to Loads

Current value (I_{sn}) per channel, [A]	AKB331 cable length							
	15 m	10 m	7 m	5 m	3 m	2 m	1 m	0.6 m
0.1	478.6	647.0	748.1	815.5	882.8	916.5	950.2	963.7
0.2	451.3	628.4	734.7	805.6	876.4	911.9	947.3	961.5
0.3	246.5	545.9	721.3	795.7	870.0	907.2	944.4	959.2
0.4	Not applicable	250.9	430.5	550.3	670.1	729.9	789.8	813.8
0.5	Not applicable	73.9	253.5	373.3	493.1	552.9	612.8	636.8
0.6	Not applicable	Not applicable	135.5	255.3	375.1	434.9	494.8	518.8

Note: In addition to the influence of voltage drop and wiring capacitance, possible cable length may be shorter when the short circuit detection during output OFF is needed. The above table shows the case that short circuit detection is taken into account. Columns grey in the above table are the area influenced by the short circuit detection.

- In case AKB651 cable is used at the external power supply voltage (V_p [V]) of 28.8 V.

Table Possible cable Length, L_s [m], (when Using 2.5 mm²) from the Terminal Board to Loads

Current value (I_{sn}) per channel, [A]	AKB651 cable length								
	30 m	25 m	20 m	15 m	10 m	7 m	5 m	3 m	2 m
0.1	715.2	760.0	804.7	849.5	894.3	921.2	939.1	957.0	966.0
0.2	700.1	747.2	794.3	841.4	888.5	916.8	935.6	954.4	963.9
0.3	667.0	734.4	783.8	833.3	882.7	912.3	932.1	951.9	961.8
0.4	372.0	451.6	531.3	610.9	690.5	738.2	770.1	801.9	817.9
0.5	195.0	274.6	354.3	433.9	513.5	561.2	593.1	624.9	640.9
0.6	77.0	156.6	236.2	315.9	395.5	443.2	475.1	506.9	522.9

Note: In addition to the influence of voltage drop and wiring capacitance, possible cable length may be shorter when the short circuit detection during output OFF is needed. The above table shows the case that short circuit detection is taken into account. Columns grey in the above table are the area influenced by the short circuit detection.

MIL Connector is Connected

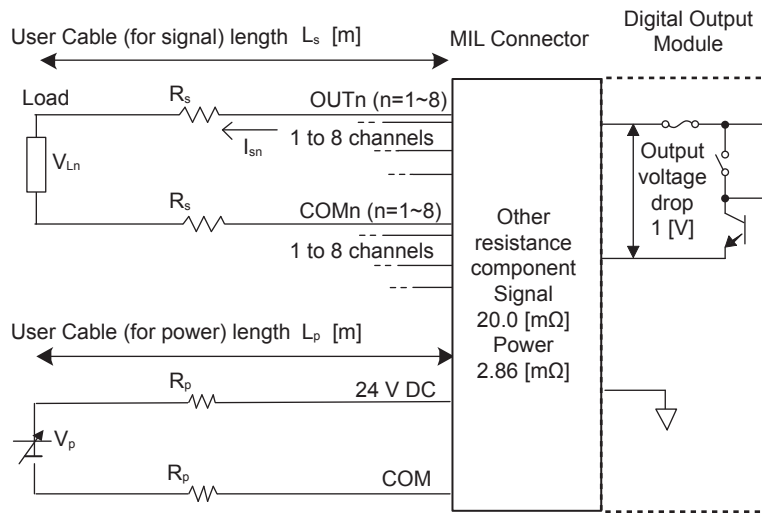

F08E.ai

Where a MIL connector is used, assuming that:

- the external power supply voltage is expressed as V_p [V],
- user cable (power) length as L_p [m],
- user cable (power) resistance value as R_p [Ω/m],
- user cable (signal) length as L_s [m],
- user cable (signal) resistance value R_s [Ω/m],
- total value of current flowing through channel 1 to channel 8 as $I_{p\Sigma}$,
- current flowing through n-channel as I_{sn} [A], and
- voltage supplied to loads connected to n-channel as V_{Ln} [V].

The voltage drop from the external power supply (V_p) to the output channel load is a total voltage drop of $\Delta V1$ in the power line, $\Delta V2$ in the signal line and $\Delta V3$ in the circuit inside Digital Output Module. Therefore, the voltage supplied to the load connected to a channel is expressed by:

$$\begin{aligned}
 V_{Ln} &= V_p - (\Delta V1 + \Delta V2 + \Delta V3) \\
 &= V_p - (R_p \times L_p \div 7 \times 0.00286) \times I_{p\Sigma} - (R_s \times L_s \times 2 + 0.0200) \times I_{sn} - 1
 \end{aligned}$$

[References]

The following shows a possible user signal cable length L_s [m] when changing the length, L_p [m], of the power supply cable and the value of the current, I_{sn} [A], flowing through n-channel as in the table below.

Other parameters are given below:

R_p [Ω/m]	0.058	User cable (power) resistance value (when using AWG22)
R_s [Ω/m]	0.058	User cable (signal) resistance value (when using AWG22)
V_{Ln} [V]	21.6	Voltage supplied to loads connected to n-channel
$I_{p\Sigma}$ [A]	$(I_{sn} \times 8)$	Total value of current flowing through channel 1 to channel 8

Wiring capacitance of User cable is calculated with the parameters given below:

User cable (signal) wiring capacitance	50 [pF/m]
Field devices capacitance	0 [pF]

- In case the external power supply voltage (V_p [V]) is 28.8 V.

Table Possible Cable Length, L_s [m], (when Using AWG22) from MIL Connector to Loads

Current value (I_{sn}) per channel, [A]	Power Supply cable length L_p							
	15 m	10 m	7 m	5 m	3 m	2 m	1 m	0.6 m
0.1	137.5	138.5	139.1	139.5	140.0	140.2	140.4	140.4
0.2	136.5	137.9	138.7	139.2	139.8	140.0	140.3	140.4
0.3	135.6	137.2	138.2	138.9	139.6	139.9	140.2	140.3
0.4	116.1	121.8	125.3	127.5	129.8	131.0	132.1	132.6
0.5	89.4	95.1	98.5	100.8	103.1	104.2	105.4	105.8
0.6	71.6	77.3	80.7	83.0	85.3	86.4	87.6	88.0

Note: In addition to the influence of voltage drop and wiring capacitance, possible cable length may be shorter when the short circuit detection during output OFF is needed. The above table shows the case that short circuit detection is taken into account. Columns grey in the above table are the area influenced by the short circuit detection.

Pressure Clamp Terminal Block is Connected

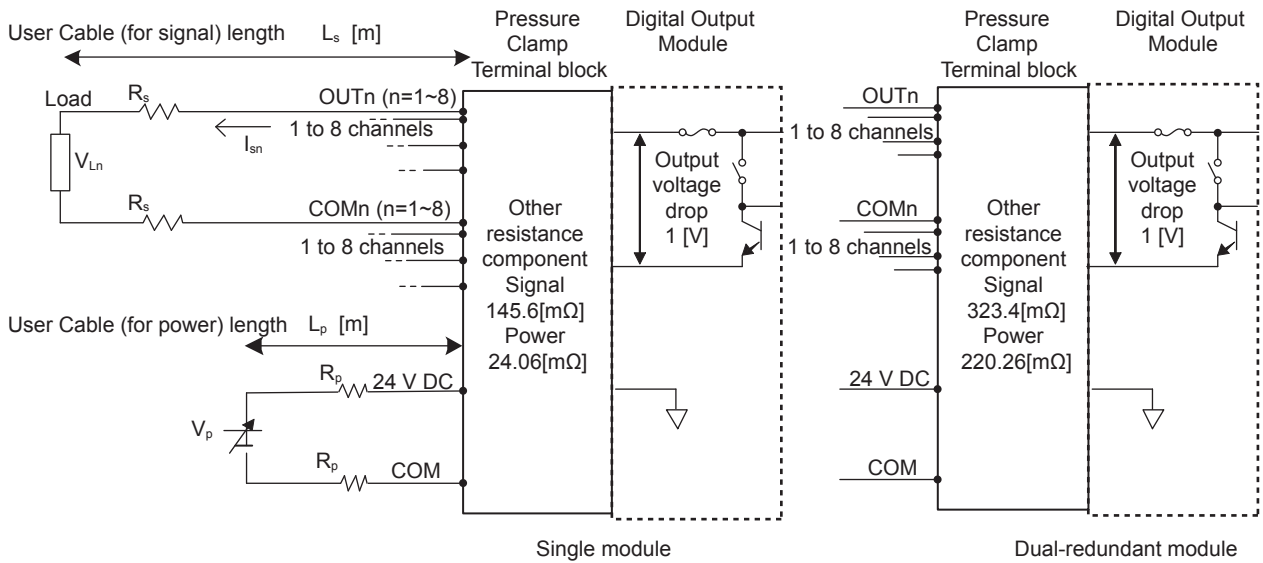

F09E.ai

If the digital output module connection is configured with a pressure clamp terminal block, observe the following preconditions:

- the external power supply voltage is expressed as V_p [V],
- user cable (power) length as L_p [m],
- user cable (power) resistance value as R_p [Ω/m],
- user cable (signal) length as L_s [m],
- user cable (signal) resistance value R_s [Ω/m],
- total value of current flowing through channel 1 to channel 8 as $I_{p\Sigma}$
- current flowing through n-channel as I_{sn} [A], and
- voltage supplied to loads connected to n-channel as V_{Ln} [V].

The voltage drop from the external power supply (V_p) to the output channel load is a total voltage drop of $\Delta V1$ in the power line, $\Delta V2$ in the signal line and $\Delta V3$ in the circuit inside Digital Output Module. Therefore, the voltage supplied to the load connected to a channel is expressed by:

• **Single Module**

$$V_{Ln} = V_p - (\Delta V1 + \Delta V2 + \Delta V3)$$

$$= V_p - (R_p \times L_p \times 2 + 0.02406) \times I_{p\Sigma} - (R_s \times L_s \times 2 + 0.1456) \times I_{sn} - 1$$

• **Dual-redundant Module**

$$V_{Ln} = V_p - (\Delta V1 + \Delta V2 + \Delta V3)$$

$$= V_p - (R_p \times L_p \times 2 + 0.22026) \times I_{p\Sigma} - (R_s \times L_s \times 2 + 0.3234) \times I_{sn} - 1$$

[References]

The following shows a possible user signal cable length L_s [m] when changing the length, L_p [m], of a power supply cable and the current, I_{sn} [A], flowing through n-channel as in the table below.

Other parameters are given below:

R_p [Ω/m]	0.0096	User cable (power) resistance value (when using AWG14)
R_s [Ω/m]	0.0096	User cable (signal) resistance value (when using AWG14)
V_{Ln} [V]	21.6	Voltage supplied to loads connected to n-channel
$I_{p\Sigma}$ [A]	$(I_{sn} \times 8)$	Total value of current flowing through channel 1 to channel 8

Wiring capacitance of User cable is calculated with the parameters given below:

User cable (signal) wiring capacitance	50 [pF/m]
Field devices capacitance	0 [pF]

- In case the single module is used at the external power supply voltage (V_p [V]) of 28.8 V.

Table Possible Cable Length, L_s [m], (when Using AWG14) from Pressure Clamp Terminal Block to Loads

Current value (I_{sn}) per channel, [A]	Power Supply cable length L_p							
	15 m	10 m	7 m	5 m	3 m	2 m	1 m	0.6 m
0.1	819.6	826.8	831.1	833.9	836.8	838.3	839.7	840.3
0.2	812.5	821.8	827.5	831.2	835.0	836.8	838.7	839.5
0.3	805.4	816.9	823.9	828.5	833.1	835.4	837.7	838.7
0.4	669.7	709.7	733.7	749.7	765.7	773.7	781.7	784.9
0.5	508.2	548.2	572.2	588.2	604.2	612.2	620.2	623.4
0.6	400.6	440.6	464.6	480.6	496.6	504.6	512.6	515.8

Note: In addition to the influence of voltage drop and wiring capacitance, possible cable length may be shorter when the short circuit detection during output OFF is needed. The above table shows the case that short circuit detection is taken into account. Columns grey in the above table are the area influenced by the short circuit detection.

- In case the dual-redundant module is used at the external power supply voltage (V_p [V]) of 28.8 V.

Table Possible Cable Length, L_s [m], (when Using AWG14) from Pressure Clamp Terminal Block to Loads

Current value (I_{sn}) per channel, [A]	Power Supply cable length L_p							
	15 m	10 m	7 m	5 m	3 m	2 m	1 m	0.6 m
0.1	795.6	802.8	807.1	810.0	812.9	814.3	815.7	816.3
0.2	784.0	793.4	799.0	802.8	806.5	808.4	810.3	811.0
0.3	772.5	784.0	791.0	795.6	800.2	802.5	804.8	805.8
0.4	578.7	618.7	642.7	658.7	674.7	682.7	690.7	693.9
0.5	417.2	457.2	481.2	497.2	513.2	521.2	529.2	552.4
0.6	309.6	349.6	373.6	389.6	405.6	413.6	421.6	424.8

Note: In addition to the influence of voltage drop and wiring capacitance, possible cable length may be shorter when the short circuit detection during output OFF is needed. The above table shows the case that short circuit detection is taken into account. Columns grey in the above table are the area influenced by the short circuit detection.

● SDV541

Terminal Board is Connected

The SDV541 digital output module can respectively handle a maximum of 0.2 A load currents per channel. However, this can cause the generation of a voltage drop due to connected cable and adapter resistance components, etc. Therefore, it is necessary to take account of the limitations on the magnitude of load current and connected cable length as given below.

In case of short circuits detection is enabled, the possible cable length may be limited.

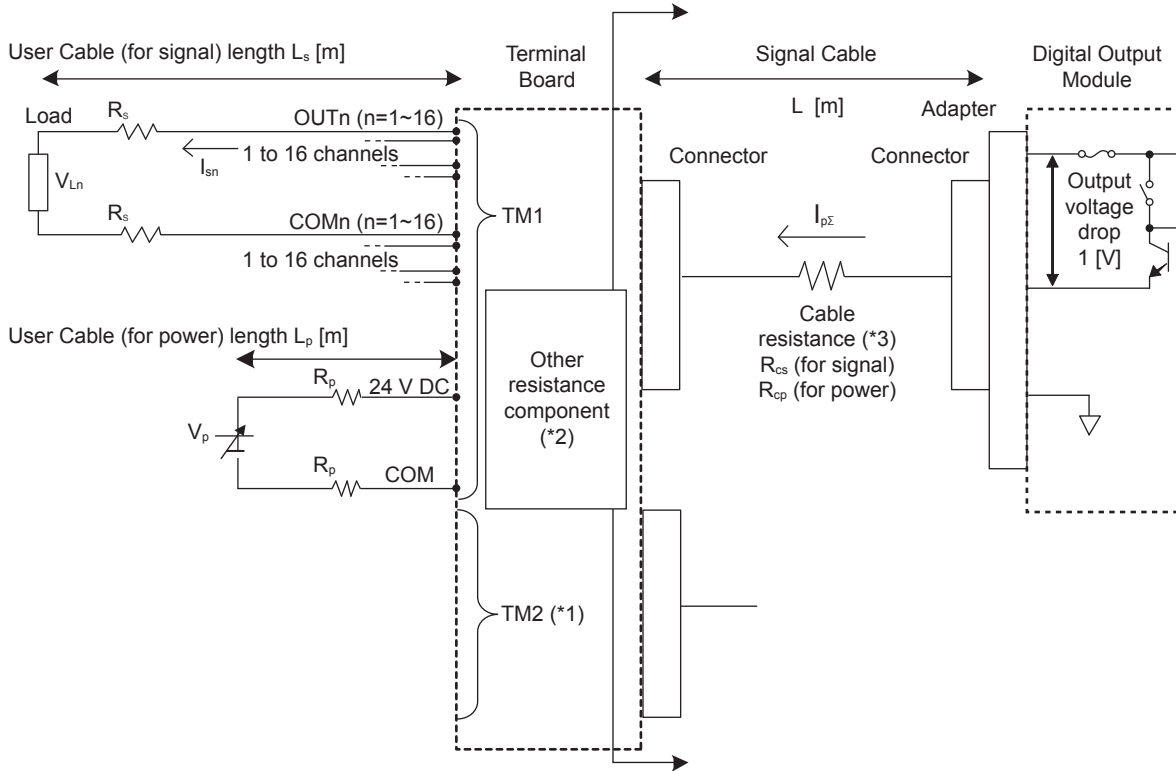

F15E.ai

*1: TM1 only for SBD4D

*2: Other resistance component is given below:

Table Other resistance component vs. Terminal board

Terminal board model No.	Connection module model No.	Other resistance component [mΩ] (By 1 channel)	
		Signal	Power
SED4D	SDV541	202.8	56.36
SBD4D	SDV541	222.1	34.72

*3: Cable resistance is given below:

Table Signal cable vs. Cable resistance

Signal cable model No.	Cable resistance [mΩ/m]	
	R _{cs} (for signal)	R _{cp} (for power)
AKB331	446.0	63.71
AKB651	118.6	16.94

If the digital output module connection is configured with a terminal board, signal cable, and adapter for signal cable, observe the following preconditions:

- the external power supply voltage is expressed as V_p [V],
- user cable (power) length as L_p [m],
- user cable (power) resistance value as R_p [Ω /m],
- user cable (signal) length as L_s [m],
- user cable (signal) resistance value as R_s [Ω /m],
- signal cable length as L [m],
- signal cable (signal) resistance value as R_{cs} [Ω /m],
- signal cable (power) resistance value as R_{cp} [Ω /m],
- total value of current flowing through channel 1 to channel 16 as $I_{p\Sigma}$ [A],
- current flowing through n-channel as I_{sn} [A] and
- voltage supplied to loads connected to n-channel as V_{Ln} [V].

For SED4D

The voltage drop from the external power supply (V_p) to the output channel load is a total voltage drop of $\Delta V1$ in the power line, $\Delta V2$ in the signal line and $\Delta V3$ in the circuit inside Digital Output Module. Therefore, the voltage supplied to the load connected to a channel is expressed by:

$$\begin{aligned}
 V_{Ln} &= V_p - (\Delta V1 + \Delta V2 + \Delta V3) \\
 &= V_p - (R_p \times L_p \times 2 + R_{cp} \times L + 0.05636) \times I_{p\Sigma} \\
 &\quad - (R_s \times L_s \times 2 + R_{cs} \times L + 0.2028) \times I_{sn} - 1
 \end{aligned}$$

[References]

The following shows a possible user signal cable length L_s [m] when changing the length, L [m], of a AKB331 signal cable and the current, I_{sn} [A], flowing through n-channel as in the table below.

Other parameters are given below:

- L_p [m] 0.5 User cable (power) length
- R_p [Ω /m] 0.0096 User cable (power) resistance value (when using AWG14)
- R_s [Ω /m] 0.0096 User cable (signal) resistance value (when using AWG14)
- V_{Ln} [V] 21.6 Voltage supplied to loads connected to n-channel
- $I_{p\Sigma}$ [A] ($I_{sn} \times 16$) Total value of current flowing through channel 1 to channel 16
- The capacitance of an AKB331 cable 60 [pF/m]

Wiring capacitance of User cable is calculated with the parameters given below:

- User cable (signal) wiring capacitance 50 [pF/m]
- Field devices capacitance 0 [pF]

- In case the external power supply voltage (V_p [V]) is 28.8 V.

Table Possible Cable Length, L_s [m], (when Using AWG14) from the Terminal Board to Loads

Current value (I_{sn}) per channel, [A]	AKB331 cable length							
	15 m	10 m	7 m	5 m	3 m	2 m	1 m	0.6 m
0.1	1694.4	1868.6	1973.1	1994.0	1996.4	1997.6	1998.8	1999.3
0.2	404.2	785.8	1014.8	1167.5	1320.1	1396.4	1472.7	1503.3

Note: In addition to the influence of voltage drop and wiring capacitance, possible cable length may be shorter when the short circuit detection during output OFF is needed. The above table shows the case that short circuit detection is taken into account.

AKB331 Cable length is from 0.6 to 5 m:

Columns grey in the above table are the area influenced by the wiring capacitance.

AKB331 Cable length is from 7 to 15 m:

Columns grey in the above table are the area influenced by the short circuit detection.

For SBD4D

SBD4D has parallel diode inside in order to use dual-redundant configuration power supply.

The voltage drop of this diode shows 0.55 V. An external power supply shall be specified as additional 0.55 V within the applicable voltage range 28.8 V maximum of the SBD4D.

The voltage drop from the external power supply (V_p) to the output channel load is a total voltage drop of $\Delta V1$ in the power line, $\Delta V2$ in the signal line and $\Delta V3$ in the circuit inside Digital Output Module. Therefore, the voltage supplied to the load connected to a channel is expressed by:

$$V_{Ln} = V_p - (\Delta V1 + \Delta V2 + \Delta V3)$$

$$= V_p - (R_p \times L_p \times 2 + R_{cp} \times L + 0.03472) \times I_{p\Sigma} - 0.55 - (R_s \times L_s \times 2 + R_{cs} \times L + 0.22212) \times I_{sn} - 1$$

[References]

The following shows a possible user signal cable length L_s [m] when changing the length, L [m], of a signal cable and the current, I_{sn} [A], flowing through n-channel as in the table below.

Other parameters are given below:

L_p [m]	0.5	User cable (power) length
R_p [Ω /m]	0.00798	User cable (power) resistance value (when using 2.5 mm ²)
R_s [Ω /m]	0.00798	User cable (signal) resistance value (when using 2.5 mm ²)
V_{Ln} [V]	21.6	Voltage supplied to loads connected to n-channel
$I_{p\Sigma}$ [A]	($I_{sn} \times 16$)	Total value of current flowing through channel 1 to channel 16
The capacitance of an AKB331 cable	60 [pF/m]	
The capacitance of an AKB651 cable	200 [pF/m]	

Wiring capacitance of User cable is calculated with the parameters given below:

User cable (signal) wiring capacitance	50 [pF/m]
Field devices capacitance	0 [pF]

- In case AKB331 cable is used at the external power supply voltage (V_p [V]) of 28.8 V.

Table Possible cable Length, L_s [m], (when Using 2.5 mm²) from the Terminal Board to Loads

Current value (I_{sn}) per channel, [A]	AKB331 cable length							
	15 m	10 m	7 m	5 m	3 m	2 m	1 m	0.6 m
0.1	1982.0	1988.0	1991.6	1994.0	1996.4	1997.6	1998.8	1999.3
0.2	336.1	795.2	1070.6	1254.3	1437.9	1529.7	1621.5	1658.2

Note: In addition to the influence of voltage drop and wiring capacitance, possible cable length may be shorter when the short circuit detection during output OFF is needed. The above table shows the case that short circuit detection is taken into account. Columns grey in the above table are the area influenced by the wiring capacitance.

- In case AKB651 cable is used at the external power supply voltage (V_p [V]) of 28.8 V.

Table Possible cable Length, L_s [m], (when Using 2.5 mm²) from the Terminal Board to Loads

Current value (I_{sn}) per channel, [A]	AKB651 cable length								
	30 m	25 m	20 m	15 m	10 m	7 m	5 m	3 m	2 m
0.1	1880.0	1900.0	1920.0	1940.0	1960.0	1972.0	1980.0	1988.0	1992.0
0.2	980.9	1103.0	1225.1	1347.1	1469.2	1542.4	1591.3	1640.1	1664.5

Note: In addition to the influence of voltage drop and wiring capacitance, possible cable length may be shorter when the short circuit detection during output OFF is needed. The above table shows the case that short circuit detection is taken into account. Columns grey in the above table are the area influenced by the wiring capacitance.

MIL Connector is Connected

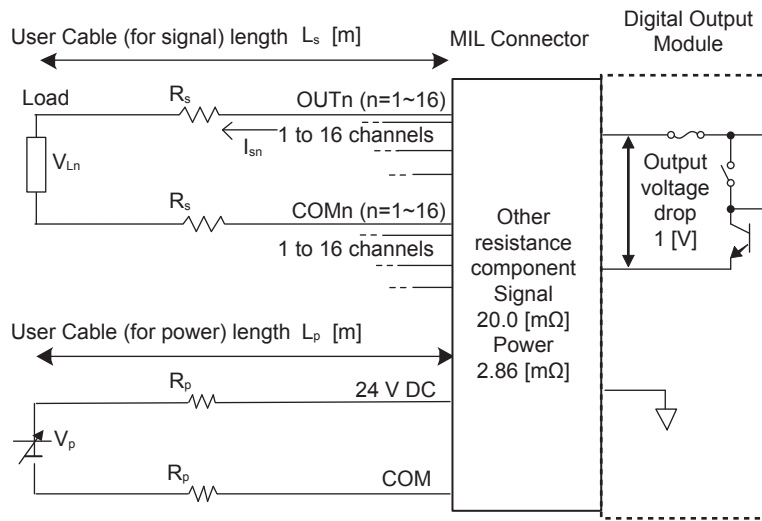

F16E.ai

Where a MIL connector is used, assuming that:

- the external power supply voltage is expressed as V_p [V],
- user cable (power) length as L_p [m],
- user cable (power) resistance value as R_p [Ω/m],
- user cable (signal) length as L_s [m],
- user cable (signal) resistance value R_s [Ω/m],
- total value of current flowing through channel 1 to channel 16 as $I_{p\Sigma}$,
- current flowing through n-channel as I_{sn} [A], and
- voltage supplied to loads connected to n-channel as V_{Ln} [V].

The voltage drop from the external power supply (V_p) to the output channel load is a total voltage drop of $\Delta V1$ in the power line, $\Delta V2$ in the signal line and $\Delta V3$ in the circuit inside Digital Output Module. Therefore, the voltage supplied to the load connected to a channel is expressed by:

$$V_{Ln} = V_p - (\Delta V1 + \Delta V2 + \Delta V3)$$

$$= V_p - (R_p \times L_p \div 7 \times 0.00286) \times I_{p\Sigma} - (R_s \times L_s \times 2 + 0.0200) \times I_{sn} - 1$$

[References]

The following shows a possible user signal cable length L_s [m] when changing the length, L_p [m], of the power supply cable and the value of the current, I_{sn} [A], flowing through n-channel as in the table below.

Other parameters are given below:

R_p [Ω/m]	0.058	User cable (power) resistance value (when using AWG22)
R_s [Ω/m]	0.058	User cable (signal) resistance value (when using AWG22)
V_{Ln} [V]	21.6	Voltage supplied to loads connected to n-channel
$I_{p\Sigma}$ [A]	$(I_{sn} \times 16)$	Total value of current flowing through channel 1 to channel 16

Wiring capacitance of User cable is calculated with the parameters given below:

User cable (signal) wiring capacitance	50 [pF/m]
Field devices capacitance	0 [pF]

- In case the external power supply voltage (V_p [V]) of 28.8 V.

Table Possible Cable Length, L_s [m], (when Using AWG22) from MIL Connector to Loads

Current value (I_{sn}) per channel, [A]	Power Supply cable length L_p							
	15 m	10 m	7 m	5 m	3 m	2 m	1 m	0.6 m
0.1	362.9	365.4	366.9	367.9	368.9	369.4	369.9	370.1
0.2	232.4	243.8	250.7	255.2	259.8	262.1	264.4	265.3

Note: In addition to the influence of voltage drop and wiring capacitance, possible cable length may be shorter when the short circuit detection during output OFF is needed. The above table shows the case that short circuit detection is taken into account. Columns grey in the above table are the area influenced by the short circuit detection.

Pressure Clamp Terminal Block is Connected

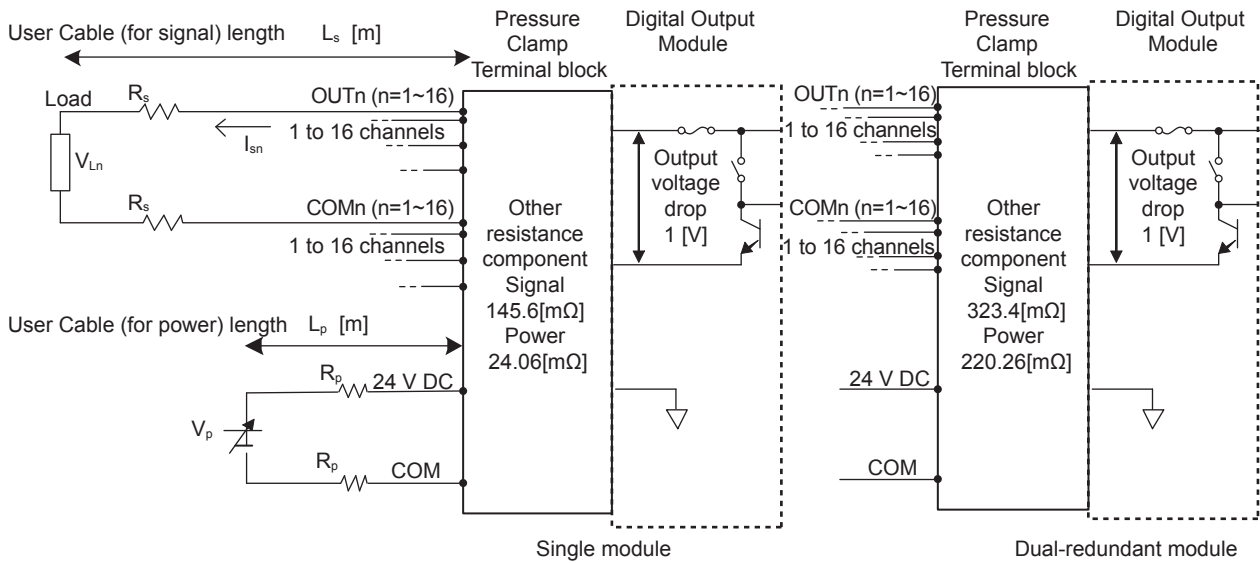

F17E.ai

If the digital output module connection is configured with a pressure clamp terminal block, observe the following preconditions:

- the external power supply voltage is expressed as V_p [V],
- user cable (power) length as L_p [m],
- user cable (power) resistance value as R_p [Ω/m],
- user cable (signal) length as L_s [m],
- user cable (signal) resistance value R_s [Ω/m],
- total value of current flowing through channel 1 to channel 16 as $I_{p\Sigma}$,
- current flowing through n-channel as I_{sn} [A], and
- voltage supplied to loads connected to n-channel as V_{Ln} [V].

The voltage drop from the external power supply (V_p) to the output channel load is a total voltage drop of $\Delta V1$ in the power line, $\Delta V2$ in the signal line and $\Delta V3$ in the circuit inside Digital Output Module. Therefore, the voltage supplied to the load connected to a channel is expressed by:

• Single Module

The calculation formula is different between channels 1 to 8 and channels 9 to 16 of the SDV541 module; possible cable lengths in channels 9 to 16 are shorter than those in channels 1 to 8.

Channels 1 to 8

The same calculation formula is given below:

$$V_{Ln} = V_p - (\Delta V1 + \Delta V2 + \Delta V3) \\ = V_p - (R_p \times L_p \times 2 + 0.02406) \times I_{p\Sigma} - (R_s \times L_s \times 2 + 0.1456) \times I_{sn} - 1$$

However in this case, it is recommended that channels 1 to 8 be used following the specifications for channels 9 to 16.

Channels 9 to 16

The calculation formula is given below:

$$V_{Ln} = V_p - (\Delta V1 + \Delta V2 + \Delta V3) \\ = V_p - (R_p \times L_p \times 2 + 0.02406) \times I_{p\Sigma} - (R_s \times L_s \times 2 + 0.9584) \times I_{sn} - 1$$

• Dual-redundant Module

$$V_{Ln} = V_p - (\Delta V1 + \Delta V2 + \Delta V3) \\ = V_p - (R_p \times L_p \times 2 + 0.22026) \times I_{p\Sigma} - (R_s \times L_s \times 2 + 0.3234) \times I_{sn} - 1$$

[References]

The following shows a possible user signal cable length L_s [m] when changing the length, L_p [m], of a power supply cable and the current, I_{sn} [A], flowing through n-channel as in the table below.

Other parameters are given below:

R_p [Ω/m]	0.0096	User cable (power) resistance value (when using AWG14)
R_s [Ω/m]	0.0096	User cable (signal) resistance value (when using AWG14)
V_{Ln} [V]	21.6	Voltage supplied to loads connected to n-channel
$I_{p\Sigma}$ [A]	$(I_{sn} \times 16)$	Total value of current flowing through channel 1 to channel 16

Wiring capacitance of User cable is calculated with the parameters given below:

User cable (signal) wiring capacitance	50 [pF/m]
Field devices capacitance	0 [pF]

- In case the single module is used at the external power supply voltage (V_p [V]) of 28.8 V.

Table Possible Cable Length, L_s [m], (when Using AWG14) from Pressure Clamp Terminal Block to Loads

Current value (I_{sn}) per channel, [A]	Power Supply cable length L_p							
	15 m	10 m	7 m	5 m	3 m	2 m	1 m	0.6 m
0.1	2000.0	2000.0	2000.0	2000.0	2000.0	2000.0	2000.0	2000.0
0.2	1304.6	1384.6	1432.6	1464.6	1496.6	1512.6	1528.6	1535.0

Note: In addition to the influence of voltage drop and wiring capacitance, possible cable length may be shorter when the short circuit detection during output OFF is needed. The above table shows the case that short circuit detection is taken into account. Columns grey in the above table are the area influenced by the wiring capacitance.

- In case the dual-redundant module is used at the external power supply voltage (V_p [V]) of 28.8 V.

Table Possible Cable Length, L_s [m], (when Using AWG14) from Pressure Clamp Terminal Block to Loads

Current value (I_{sn}) per channel, [A]	Power Supply cable length L_p							
	15 m	10 m	7 m	5 m	3 m	2 m	1 m	0.6 m
0.1	2000.0	2000.0	2000.0	2000.0	2000.0	2000.0	2000.0	2000.0
0.2	1174.2	1254.2	1302.2	1334.2	1366.2	1382.2	1398.2	1404.6

Note: In addition to the influence of voltage drop and wiring capacitance, possible cable length may be shorter when the short circuit detection during output OFF is needed. The above table shows the case that short circuit detection is taken into account. Columns grey in the above table are the area influenced by the wiring capacitance.

● SDV521

Terminal Board is Connected

The SDV521 digital output module can be connected only to terminal board via signal cable (AKB651). In this configuration, the generation of a voltage drop which is commensurate with load current depending on the ohmic value. Therefore, it is necessary to take account of the following limitations.

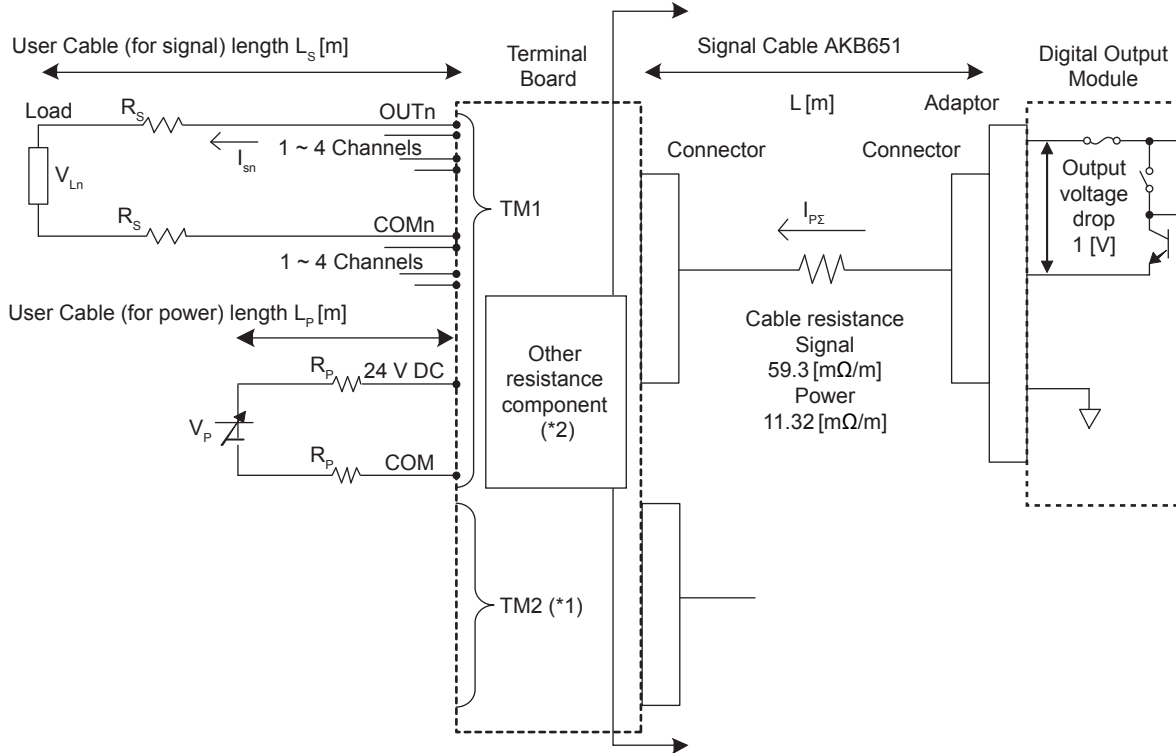

F10E.ai

- *1: TM1 only for SBD2D
- *2: Other resistance component is given below:

Table Other resistance component vs. Terminal board

Terminal board model No.	Connectionmodule model No.	Other resistance component [mΩ] (By 1 channel)	
		Signal	Power
SED2D	SDV521	60.0	42.64
SBD2D	SDV521	57.7	20.59

Terminal Board is Connected

Observe the following preconditions:

- the external power supply voltage is expressed as V_p [V],
- user cable (power) length as L_p [m],
- user cable (power) resistance value as R_p [Ω/m],
- user cable (signal) length as L_s [m],
- user cable (signal) resistance value as R_s [Ω/m],
- signal cable (AKB651) length as L [m],
- total value of current flowing through channel 1 to channel 4 as $I_{pΣ}$ [A],
- current flowing through n-channel as I_{sn} [A], and
- voltage supplied to loads connected to n-channel as V_{Ln} [V].

In case of short circuit detection is enabled, the possible cable length may be limited. Possible cable length applies to SDV521-S□3 style S3 and unit revision U:1 or later, or SDV521-S□C style S3 and unit revision U:0 or later.

For SED2D

The voltage drop from the external power supply (V_p) to the output channel load is a total of a voltage drop of $\Delta V1$ in the power line, $\Delta V2$ in the signal line and $\Delta V3$ in the circuit inside Digital Output Module. Therefore, the voltage supplied to the load connected to a channel is expressed by:

$$V_{Ln} = V_p - (\Delta V1 + \Delta V2 + \Delta V3)$$

$$= V_p - (R_p \times L_p \times 2 + 0.01132 \times L + 0.04264) \times I_{p\Sigma} - (R_s \times L_s \times 2 + 0.0593 \times L + 0.0600) \times I_{sn} - 1$$

[References]

The following shows a possible user signal cable length L_s [m] when changing the length, L [m], of the power cable (AKB651 cable) and the value of the current, I_{sn} [A], flowing through n-channel as in the table below.

Other parameters are given below:

L_p [m]	3.0	User cable (power) length
R_p [Ω /m]	0.0038	User cable (power) resistance value (when using AWG10)
R_s [Ω /m]	0.0038	User cable (signal) resistance value (when using AWG10)
V_{Ln} [V]	21.6	Voltage supplied to loads connected to n-channel
$I_{p\Sigma}$ [A]	($I_{sn} \times 4$)	Total value of current flowing through channel 1 to channel 4
The capacitance of an AKB651 cable	200 [pF/m]	

Wiring capacitance of User cable is calculated with the parameters given below:

User cable (signal) wiring capacitance	50 [pF/m]
Field devices capacitance	0 [pF]

- In case the external power supply voltage (V_p [V]) is 28.8 V.

Table Possible cable Length, L_s [m], (when Using AWG10) from the Terminal Board to Load

Current value (I_{sn}) per channel, [A]	AKB651 cable length							
	20 m	15 m	10 m	7 m	5 m	3 m	2 m	1 m
0.1	1920.0	1940.0	1960.0	1972.0	1980.0	1988.0	1992.0	1996.0
0.2	1920.0	1940.0	1960.0	1972.0	1980.0	1988.0	1992.0	1996.0
0.3	1920.0	1940.0	1960.0	1972.0	1980.0	1988.0	1992.0	1996.0
0.4	1721.9	1790.7	1859.5	1900.8	1928.3	1955.9	1969.6	1983.4
0.5	1314.0	1382.8	1451.6	1492.9	1520.4	1548.0	1561.7	1575.5
0.6	1042.1	1110.9	1179.7	1221.0	1248.5	1276.0	1289.8	1303.6
0.8	702.2	771.0	839.8	881.1	908.6	936.1	949.9	936.6
1.0	498.2	567.0	635.8	677.1	704.7	732.2	745.9	759.7
1.5	226.3	295.1	363.9	405.2	432.7	460.2	474.0	487.8
2.0	90.3	159.2	228.0	269.2	296.8	324.3	338.0	351.8

Note: In addition to the influence of voltage drop and wiring capacitance, possible cable length may be shorter when the short circuit detection of the field wiring during output OFF is needed. Maximum cable length which the short circuit of the field wiring can be detected during output OFF varies with the characteristics of the equipment's inrush current value at on-pulse test. The above table shows the case that short circuit detection is taken into account with the inrush current value of 0.5A or less. Columns grey in the above table are the area influenced by the wiring capacitance.

For SBD2D

SBD2D has parallel diode inside in order to use dual-redundant configuration power supply.

The voltage drop of this diode shows 0.55 V. An external power supply shall be specified as additional 0.55 V within the applicable voltage range 28.8 V maximum of the SBD2D.

The voltage drop from the external power supply (V_p) to the output channel load is a total of a voltage drop of $\Delta V1$ in the power line, $\Delta V2$ in the signal line and $\Delta V3$ in the circuit inside Digital Output Module. Therefore, the voltage supplied to the load connected to a channel is expressed by:

$$V_{Ln} = V_p - (\Delta V1 + \Delta V2 + \Delta V3) \\ = V_p - (R_p \times L_p \times 2 + 0.01132 \times L + 0.02059) \times I_{p\Sigma} - 0.55 - (R_s \times L_s \times 2 + 0.0593 \times L + 0.05774) \times I_{sn} - 1$$

[References]

The following shows a possible user signal cable length L_s [m] when changing the length, L [m], of the power cable (AKB651 cable) and the value of the current, I_{sn} [A], flowing through n-channel as in the table below.

Other parameters are given below:

L_p [m]	3.0	User cable (power) length
R_p [Ω /m]	0.00798	User cable (power) resistance value (when using 2.5 mm ²)
R_s [Ω /m]	0.00798	User cable (signal) resistance value (when using 2.5 mm ²)
V_{Ln} [V]	21.6	Voltage supplied to loads connected to n-channel
$I_{p\Sigma}$ [A]	($I_{sn} \times 4$)	Total value of current flowing through channel 1 to channel 4
The capacitance of an AKB651 cable	200 [pF/m]	

Wiring capacitance of User cable is calculated with the parameters given below:

User cable (signal) wiring capacitance	50 [pF/m]
Field devices capacitance	0 [pF]

- In case the external power supply voltage (V_p [V]) is 28.8 V.

Table Possible cable Length, L_s [m], (when Using 2.5 mm²) from the Terminal Board to Load

Current value (I_{sn}) per channel, [A]	AKB651 cable length							
	20 m	15 m	10 m	7 m	5 m	3 m	2 m	1 m
0.1	1125.4	1147.5	1169.7	1182.9	1191.8	1200.6	1205.0	1209.5
0.2	1125.4	1147.5	1169.7	1182.9	1191.8	1200.6	1205.0	1209.5
0.3	1028.2	1061.0	1093.7	1113.4	1126.5	1139.6	1146.2	1152.7
0.4	733.2	766.0	798.7	818.4	831.5	844.6	851.1	857.7
0.5	556.2	589.0	621.7	641.4	654.5	667.6	674.1	680.7
0.6	438.2	471.0	503.7	523.4	536.5	549.6	556.1	562.7
0.8	290.7	323.4	356.2	375.9	389.0	402.1	408.6	415.2
1.0	202.2	234.9	267.7	287.4	300.5	313.6	320.1	326.7
1.5	84.2	116.9	149.7	169.4	182.5	195.6	202.1	208.7
2.0	25.2	57.9	90.7	110.4	123.5	136.6	143.1	149.7

Note: In addition to the influence of voltage drop and wiring capacitance, possible cable length may be shorter when the short circuit detection of the field wiring during output OFF is needed. Maximum cable length which the short circuit of the field wiring can be detected during output OFF varies with the characteristics of the equipment's inrush current value at on-pulse test. The above table shows the case that short circuit detection is taken into account with the inrush current value of 0.5A or less. Columns grey in the above table are the area influenced by the short circuit detection.

● SDV526

Terminal Board is Connected

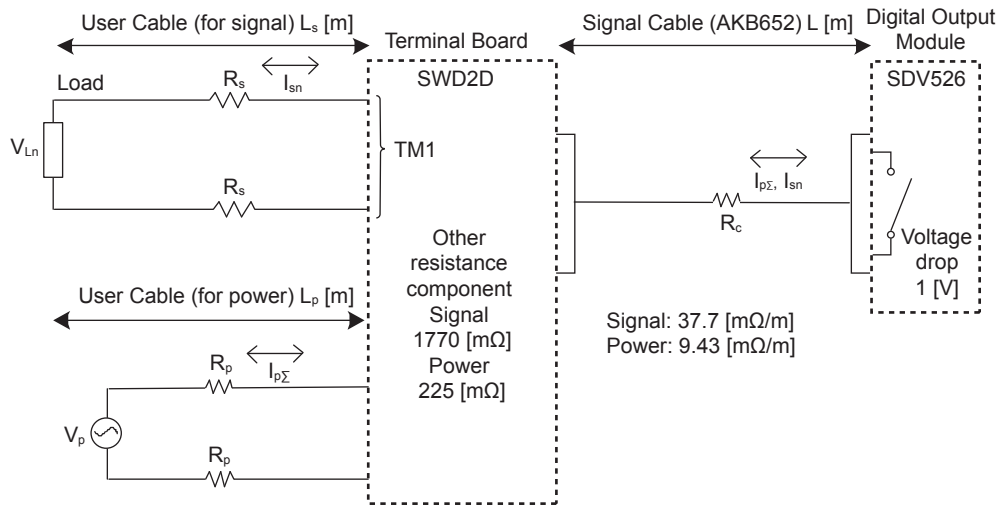

F12E.ai

Terminal Board is Connected

Observe the following preconditions:

- the external power supply voltage is expressed as V_p [V],
- user cable (power) length as L_p [m],
- user cable (power) resistance value as R_p [Ω/m],
- user cable (signal) length as L_s [m],
- user cable (signal) resistance value as R_s [Ω/m],
- signal cable (AKB652) length as L [m],
- total value of current flowing through channel 1 to channel 4 as $I_{p\Sigma}$ [A],
- current flowing through n-channel as I_{sn} [A], and
- voltage supplied to loads connected to n-channel as V_{Ln} [V].

The voltage drop from the external power supply (V_p) to the output channel load is a total voltage drop of $\Delta V1$ in the power line, $\Delta V2$ in the signal line and $\Delta V3$ in the circuit inside Digital Output Module. Therefore, the voltage supplied to load connected to a channel is expressed by:

$$\begin{aligned}
 V_{Ln} &= V_p - (\Delta V1 + \Delta V2 + \Delta V3) \\
 &= V_p - (R_p \times L_p \times 2 + 0.00943 \times L + 0.225) \times I_{p\Sigma} - (R_s \times L_s \times 2 + 0.0377 \times L + 1.77) \times I_{sn} - 1
 \end{aligned}$$

● SDV53A

Terminal Board is Connected

The SDV53A digital output module can be connected only to terminal board via signal cable. In this configuration, the generation of a voltage drop which is commensurate with load current depending on the ohmic value. Therefore, it is necessary to take account of the following limitations.

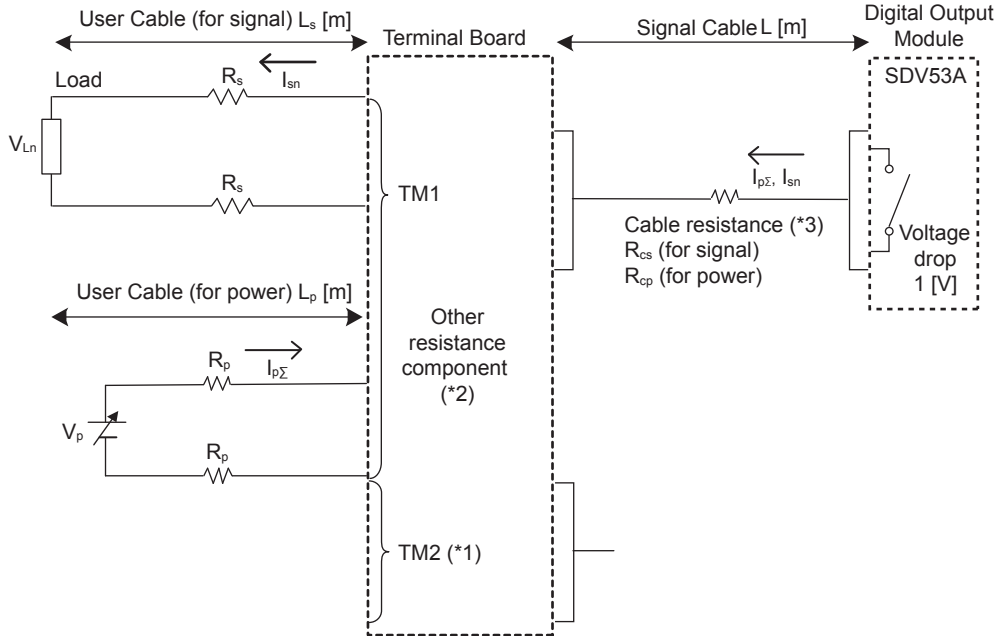

F13E.ai

*1: TM1 only for SBD4D

*2: Other resistance component is given below:

Table Other resistance component vs. Terminal board

Terminal board model No.	Connectionmodule model No.	Other resistance component [mΩ] (By 1 channel)	
		Signal	Power
SED3D	SDV53A	222	89
SBD3D	SDV53A	261	38

*3: Cable resistance is given below:

Table Signal cable vs. Cable resistance

Signal cable model No.	Cable resistance [mΩ/m]	
	R _{cs} (for signal)	R _{cp} (for power)
AKB331	446.0	63.71
AKB651	118.6	16.94

Terminal Board is Connected

Observe the following preconditions:

- the external power supply voltage is expressed as V_p [V],
- user cable (power) length as L_p [m],
- user cable (power) resistance value as R_p [Ω /m],
- user cable (signal) length as L_s [m],
- user cable (signal) resistance value as R_s [Ω /m],
- signal cable length as L [m],
- signal cable (signal) resistance value as R_{cs} [Ω /m],
- signal cable (power) resistance value as R_{cp} [Ω /m],
- total value of current flowing through channel 1 to channel 8 as $I_{p\Sigma}$ [A],
- current flowing through n-channel as I_{sn} [A], and
- voltage supplied to loads connected to n-channel as V_{Ln} [V].

In case of short circuit detection is enabled, the possible cable length may be limited.
Possible cable length applies to SDV53A-S□3 style S2 and unit revision U:1 or later.

For SED3D

The voltage drop from the external power supply (V_p) to the output channel load is a total voltage drop of $\Delta V1$ in the power line, $\Delta V2$ in the signal line and $\Delta V3$ in the circuit inside Digital Output Module. Therefore, the voltage supplied to load connected to a channel is expressed by:

$$V_{Ln} = V_p - (\Delta V1 + \Delta V2 + \Delta V3)$$

$$= V_p - (R_p \times L_p \times 2 + R_{cp} \times L + 0.0890) \times I_{p\Sigma} - (R_s \times L_s \times 2 + R_{cs} \times L + 0.222) \times I_{sn} - 1$$

[References]

The following shows a possible user signal cable length L_s [m] when changing the length, L [m], of a AKB331 signal cable and the current, I_{sn} [A], flowing through n-channel as in the table below.

Other parameters are given below:

- L_p [m] 0.5 User cable (power) length
- R_p [Ω /m] 0.0096 User cable (power) resistance value (when using AWG14)
- R_s [Ω /m] 0.0096 User cable (signal) resistance value (when using AWG14)
- V_{Ln} [V] 43.2 Voltage supplied to loads connected to n-channel
- $I_{p\Sigma}$ [A] ($I_{sn} \times 8$) Total value of current flowing through channel 1 to channel 8
- The capacitance of an AKB331 cable 60 [pF/m]

Wiring capacitance of User cable is calculated with the parameters given below:

- User cable (signal) wiring capacitance 50 [pF/m]
- Field devices capacitance 0 [pF]

- In case the external power supply voltage (V_p [V]) is 57.6 V.

Table Possible Cable Length, L_s [m], (when Using AWG14) from the Terminal Board to Loads

Current value (I_{sn}) per channel, [A]	AKB331 cable length								
	20 m	15 m	10 m	7 m	5 m	3 m	2 m	1 m	0.6 m
0.1	1976.0	1982.0	1988.0	1991.6	1994.0	1996.4	1997.6	1998.8	1999.3
0.2	1976.0	1982.0	1988.0	1991.6	1994.0	1996.4	1997.6	1998.8	1999.3
0.3	1278.2	1527.1	1776.0	1925.3	1994.0	1996.4	1997.6	1998.8	1999.3
0.4	696.6	945.5	1194.4	1343.7	1443.3	1542.8	1592.6	1642.4	1662.3
0.5	347.7	596.6	845.4	994.8	1094.3	1193.9	1243.6	1293.4	1313.3
0.6	115.0	363.9	612.8	762.1	861.7	961.2	1011.0	1060.8	1080.7

Note: In addition to the influence of voltage drop and wiring capacitance, possible cable length may be shorter when the short circuit detection of the field wiring during output OFF is needed. Maximum cable length which the short circuit of the field wiring can be detected during output OFF varies with the characteristics of the equipment's inrush current value at on-pulse test. The above table shows the case that short circuit detection is taken into account with the inrush current value of 0.6A or less. Columns grey in the above table are the area influenced by the wiring capacitance.

For SBD3D

SBD3D has parallel diode inside in order to use dual-redundant configuration power supply.

The voltage drop of this diode shows 0.6 V. An external power supply shall be specified as additional 0.6 V within the applicable voltage range 57.6 V maximum of the SBD3D.

The voltage drop from the external power supply (V_p) to the output channel load is a total voltage drop of $\Delta V1$ in the power line, $\Delta V2$ in the signal line and $\Delta V3$ in the circuit inside Digital Output Module. Therefore, the voltage supplied to load connected to a channel is expressed by:

$$V_{Ln} = V_p - (\Delta V1 + \Delta V2 + \Delta V3) \\ = V_p - (R_p \times L_p \times 2 + R_{cp} \times L + 0.03809) \times I_{p\Sigma} - 0.6 - (R_s \times L_s \times 2 + R_{cs} \times L + 0.2606) \times I_{sn} - 1$$

[References]

The following shows a possible user signal cable length L_s [m] when changing the length, L [m], of a signal cable and the current, I_{sn} [A], flowing through n-channel as in the table below.

Other parameters are given below:

L_p [m]	0.5	User cable (power) length
R_p [Ω /m]	0.00798	User cable (power) resistance value (when using 2.5 mm ²)
R_s [Ω /m]	0.00798	User cable (signal) resistance value (when using 2.5 mm ²)
V_{Ln} [V]	43.2	Voltage supplied to loads connected to n-channel
$I_{p\Sigma}$ [A]	($I_{sn} \times 8$)	Total value of current flowing through channel 1 to channel 8
The capacitance of an AKB331 cable	60 [pF/m]	
The capacitance of an AKB651 cable	200 [pF/m]	

Wiring capacitance of User cable is calculated with the parameters given below:

User cable (signal) wiring capacitance	50 [pF/m]
Field devices capacitance	0 [pF]

- In case AKB331 cable is used at the external power supply voltage (V_p [V]) is 57.6 V.

Table Possible cable Length, L_s [m], (when Using 2.5 mm²) from the Terminal Board to Load

Current value (I_{sn}) per channel, [A]	AKB331 cable length								
	20 m	15 m	10 m	7 m	5 m	3 m	2 m	1 m	0.6 m
0.1	1976.0	1982.0	1988.0	1991.6	1994.0	1996.4	1997.6	1998.8	1999.3
0.2	1976.0	1982.0	1988.0	1991.6	1994.0	1996.4	1997.6	1998.8	1999.3
0.3	1436.3	1735.7	1988.0	1991.6	1994.0	1996.4	1997.6	1998.8	1999.3
0.4	768.0	1067.4	1366.8	1546.4	1666.2	1786.0	1845.8	1905.7	1929.7
0.5	367.0	666.4	965.8	1145.4	1265.2	1384.9	1444.8	1504.7	1528.7
0.6	99.7	399.1	698.5	878.1	997.9	1117.6	1177.5	1237.4	1261.3

Note: In addition to the influence of voltage drop and wiring capacitance, possible cable length may be shorter when the short circuit detection of the field wiring during output OFF is needed. Maximum cable length which the short circuit of the field wiring can be detected during output OFF varies with the characteristics of the equipment's inrush current value at on-pulse test. The above table shows the case that short circuit detection is taken into account with the inrush current value of 0.6A or less. Columns grey in the above table are the area influenced by the wiring capacitance.

- In case AKB651 cable is used at the external power supply voltage (V_p [V]) is 57.6 V.

Table Possible cable Length, L_s [m], (when Using 2.5 mm²) from the Terminal Board to Loads

Current value (I_{sn}) per channel, [A]	AKB651 cable length								
	30 m	25 m	20 m	15 m	10 m	7 m	5 m	3 m	2 m
0.1	1880.0	1900.0	1920.0	1940.0	1960.0	1972.0	1980.0	1988.0	1992.0
0.2	1880.0	1900.0	1920.0	1940.0	1960.0	1972.0	1980.0	1988.0	1992.0
0.3	1880.0	1900.0	1920.0	1940.0	1960.0	1972.0	1980.0	1988.0	1992.0
0.4	1487.9	1567.5	1647.1	1726.8	1806.4	1854.1	1886.0	1917.8	1933.7
0.5	1086.9	1166.5	1246.1	1325.8	1405.4	1453.1	1485.0	1516.8	1532.7
0.6	819.6	899.2	978.8	1058.4	1138.0	1185.8	1217.6	1249.5	1265.4

Note: In addition to the influence of voltage drop and wiring capacitance, possible cable length may be shorter when the short circuit detection of the field wiring during output OFF is needed. Maximum cable length which the short circuit of the field wiring can be detected during output OFF varies with the characteristics of the equipment's inrush current value at on-pulse test. The above table shows the case that short circuit detection is taken into account with the inrush current value of 0.6A or less. Columns grey in the above table are the area influenced by the wiring capacitance.

● **SDV531 or SDV541 is Used with Relay Board**

When the digital output module (SDV531, SDV541) is used together with the relay board (SRM53D, SRM54D, SBM54D), the allowable tolerance of power supply voltage applied to the power terminals of the relay board varies with the length of the dedicated signal cable (AKB331), as in the Table below.

Table Allowable tolerance of power supply voltage to the relay boards

AKB331 cable length [m]	SRM53D (*1) Power supply voltage [V]		SRM54D (*2) Power supply voltage [V]		SBM54D (*2) Power supply voltage [V]			
	Lower limit	Upper limit	Lower limit	Upper limit	Lower limit	Upper limit		
1	22.92	25.2 (24 V + 5 %)	23.04	25.2 (24 V + 5 %)	22.19	28.8 (24 V + 20 %)		
2	22.96		23.11		22.22			
3	23.00		23.19		22.24			
5	23.07		23.33		22.29			
7	23.14		23.48		22.34			
10	23.25		23.70		22.41			
15	23.44		24.07		22.54			
20	23.62		24.43		22.66			
25	Not applicable		Not applicable		Not applicable		Not applicable	22.78
30								22.90
35		23.03						
40		23.15						
45		23.27						
50		23.39						

Note: The maximum length of AKB331 used for connecting to SRM53D or SRM54D is 20 m.

*1: For connecting with SDV531-□6□ or SDV531-□F□

*2: For connecting with SDV541-S6□ or SDV541-SF□

■ **TRADEMARKS**

- ProSafe is a registered trademark of Yokogawa Electric Corporation.
- Other company and product names appearing in this document are trademarks or registered trademarks of their respective holders.