

**551, 552, and 1041 Series Operator
Interface
For use with UMC800 Controller**

User Guide

Doc. No.: 51-52-25-62

Revision Date: 12/03

Notices and Trademarks

Copyright 2001 by Honeywell
Revision Dec. 2003

Warranty/Remedy

Honeywell warrants goods of its manufacture as being free of defective materials and faulty workmanship. Contact your local sales office for warranty information. If warranted goods are returned to Honeywell during the period of coverage, Honeywell will repair or replace without charge those items it finds defective. The foregoing is Buyer's sole remedy and is in lieu of all other warranties, expressed or implied, including those of merchantability and fitness for a particular purpose. Specifications may change without notice. The information we supply is believed to be accurate and reliable as of this printing. However, we assume no responsibility for its use.

While we provide application assistance personally, through our literature and the Honeywell web site, it is up to the customer to determine the suitability of the product in the application.

Industrial Measurement and Control

Honeywell
1100 Virginia Drive
Fort Washington, PA 19034

UMC800 is a U.S. registered trademarks of Honeywell

Other brand or product names are trademarks of their respective owners.

About This Document

Abstract

This manual describes the installation and operation of the 551, 552, and 1041 Series Operator Interface.

References

The following list identifies all documents that may be sources of reference for material discussed in this publication.

Document Title	Doc ID
UMC800 Controller Technical Overview	51-52-03-24
UMC800 Controller Installation and User Guide	51-52-25-61
UMC800 Control Builder User Guide	51-52-25-63
UMC800 Control Builder Function Block Reference Guide	51-52-25-64

Contacts

World Wide Web

The following lists Honeywell's World Wide Web sites that will be of interest to our customers.

Honeywell Organization	WWW Address (URL)
Corporate	http://www.honeywell.com
Industrial Measurement and Control	http://www.honeywell.com/imc
International	http://www.honeywell.com/Business/global.asp









Telephone

Contact us by telephone at the numbers listed below.

	Organization	Phone Number
United States and Canada	Honeywell	1-800-423-9883 Tech. Support 1-888-423-9883 Q&A Faxback 1-800-525-7439 (TACFAQS) Service
Asia Pacific	Honeywell Asia Pacific Hong Kong	(852) 2829-8298
Europe	Honeywell PACE, Brussels, Belgium	[32-2] 728-2111
Latin America	Honeywell, Sunrise, Florida U.S.A.	(954) 845-2600

Symbol Definitions

The following table lists those symbols that may be used in this document to denote certain conditions.

Symbol	Definition
	This DANGER symbol indicates an imminently hazardous situation, which, if not avoided, will result in death or serious injury .
	This WARNING symbol indicates a potentially hazardous situation, which, if not avoided, could result in death or serious injury .
	This CAUTION symbol may be present on Control Product instrumentation and literature. If present on a product, the user must consult the appropriate part of the accompanying product literature for more information.
CAUTION	This CAUTION symbol indicates a potentially hazardous situation, which, if not avoided, may result in property damage .
	WARNING PERSONAL INJURY: Risk of electrical shock. This symbol warns the user of a potential shock hazard where HAZARDOUS LIVE voltages greater than 30 Vrms, 42.4 Vpeak, or 60 Vdc may be accessible. Failure to comply with these instructions could result in death or serious injury.
	ATTENTION, Electrostatic Discharge (ESD) hazards. Observe precautions for handling electrostatic sensitive devices
	Protective Earth (PE) terminal. Provided for connection of the protective earth (green or green/yellow) supply system conductor.
	Functional earth terminal. Used for non-safety purposes such as noise immunity improvement. NOTE: This connection shall be bonded to protective earth at the source of supply in accordance with national local electrical code requirements.
	Earth Ground. Functional earth connection. NOTE: This connection shall be bonded to Protective earth at the source of supply in accordance with national and local electrical code requirements.
	Chassis Ground. Identifies a connection to the chassis or frame of the equipment shall be bonded to Protective Earth at the source of supply in accordance with national and local electrical code requirements.

Contents

Introduction	1
Overview.....	1
CE Conformity (Europe) - (Model 1041 pending).....	2
Overview of Architecture	3
Description of Components	3
Specifications/Mounting/Wiring/Startup.....	5
Specifications	5
Site Preparation.....	7
Operator Interface Mounting	7
Cable Connections	14
Noise Protection	16
Installing Ferrite Clamp for CE Compliance	16
Startup	17
Keys and Displays Overview.....	19
Overview of Keys.....	19
Standard Keys	21
Tasks Using Standard Keys	23
User-assignable Keys.....	27
Relabeling Display Group Keys.....	29
Overview of Displays	31
Main Menu	39
Overview.....	39
Recipes.....	40
SP Programmers	41
SP Scheduler.....	42
Loops	42
Alarms/Events/Diagnostics.....	43
Variables.....	51
Unit Setup.....	52
Disk Utilities	53

Data Storage	65
Log Off/Log On	66
Loops	67
Overview.....	67
Loop Setup	68
Loop Operation Displays	79
Setpoint Programmers	93
Overview.....	93
Setpoint Program Setup	94
Setpoint Program Operation.....	101
Setpoint Scheduler	113
Overview.....	113
Setpoint Scheduler Setup.....	114
Setpoint Schedule Operation	123
Alarms	135
Overview.....	135
Alarm Summary.....	137
Alarm Group	139
Alarm Detail.....	140
Other Operating Displays	141
Overview.....	141
Pushbuttons.....	141
4-Selector Switch.....	142
Device Control	143
Hand/Off/Auto Switch	145
Recipe Load	147
Monitoring Displays	149
Overview.....	149
Trend Displays.....	150
Bar Graph Displays	154
Panel Displays.....	155
Other Displays	159

Data Storage	161
Overview.....	161
Data Storage Operation.....	170
Maintenance	179
Overview.....	179
Unit Setup.....	179
Controller Status.....	180
Set Mode.....	181
Set Time and Date.....	182
Set Security/Review Security.....	183
Set Language.....	187
Communications Menu - Model 551/552.....	188
Communications Menu - Model 1041.....	196
File Name Selection.....	198
Self Tests.....	199
Calibrate AI.....	200
Calibrate AO.....	209
Parts.....	214
Messages	217
Overview.....	217
Appendix	225
Extending Distance from Operator Interface to Controller.....	225
Security Bypass Procedure.....	227

Multilanguage Safety Sheets

Service Centers

Tables

Table 1	Specifications	5
Table 2	Terminal assignments	15
Table 3	Standard key actions	21
Table 4	Tasks using standard keys	23
Table 5	User-assignable key actions.....	28
Table 6	Display areas defined details	31
Table 7	Main menu tree.....	33
Table 8	User-assignable displays.....	36
Table 9	Main menu functions	39
Table 10	Recipe edit details.....	40
Table 11	Details of controller diagnostics	45
Table 12	I/O module diagnostics details.....	49
Table 13	View variable details	51
Table 14	List disk files details	54
Table 15	Load/store profiles details.....	56
Table 16	Load/store schedules details	58
Table 17	Load/store recipes details	60
Table 18	Load configuration details	61
Table 19	Store configuration details.....	62
Table 20	Format disk details.....	63
Table 21	Set mode details.....	64
Table 22	Controller modes defined	64
Table 23	Log off display details	66
Table 24	Loop modes	67
Table 25	Loop menu visibility.....	69
Table 26	Details of single loop trend.....	70
Table 27	Details of loop auto tune.....	71
Table 28	Details of loop tune constants.....	72
Table 29	Details of loop control setup.....	73
Table 30	Details of carbon loop.....	75
Table 31	Details of loop alarm setpoints	76
Table 32	Details of loop limits	78
Table 33	Loop modes	79
Table 34	Details of Eight loop summary	80
Table 35	Details of Sixteen loop summary	81
Table 36	Loop control details	82
Table 37	8 loop faceplate details	83
Table 38	4 loop faceplate details	84
Table 39	3 loop faceplate details	85
Table 40	2 loop faceplate details	86
Table 41	Single loop numeric details	87
Table 42	Details of single loop faceplate with loop trend screen	88
Table 43	Loop control display details.....	89
Table 44	Details of loop tune constants display	90
Table 45	A/M bias details.....	91
Table 46	SPP inputs and current state	93
Table 47	Edit program details.....	95
Table 48	Edit segment details.....	97
Table 49	Edit segment events details.....	99
Table 50	Program save details.....	100
Table 51	Single SPP details - Model 551/552	102
Table 52	Single SPP details - Model 1041	104
Table 53	Program load details	106

Table 54	SPP operate details - Model 551/552 only.....	108
Table 55	SPP popup menu actions according to state	109
Table 56	View program events details - Model 551/552.....	109
Table 57	View program details- Model 551/552.....	110
Table 58	Edit segments details	111
Table 59	SPS inputs and current state	113
Table 60	Edit schedule details	115
Table 61	Edit segment details.....	116
Table 62	Edit setpoints details.....	117
Table 63	Edit segment events details.....	118
Table 64	Edit guarantee hold details.....	119
Table 65	Schedule save details.....	120
Table 66	Edit guarantee hold limits details.....	121
Table 67	Setpoint schedule operation details.....	124
Table 68	Setpoint schedule operation details - Model 1041	126
Table 69	Schedule load details	128
Table 70	Scheduler operate popup details	130
Table 71	SPS popup menu actions according to state	131
Table 72	View schedule events details	132
Table 73	View auxiliary data details	133
Table 74	Edit segments details	134
Table 75	Details of alarm summary.....	138
Table 76	Pushbutton details.....	141
Table 77	Four selector switch details	142
Table 78	Device control display details.....	143
Table 79	Edit device display details	144
Table 80	Hand/Off/Auto switch display details.....	145
Table 81	Set HOA switch state display details.....	146
Table 82	Example of trend details	151
Table 83	Trend menu.....	152
Table 84	Sampling rates of trends	153
Table 85	Bar graph display details	154
Table 86	4-point panel details.....	156
Table 87	Multi-point panel details.....	157
Table 88	Overview details.....	158
Table 89	Data storage point factors	162
Table 90	Preinitializing ZIP Diskette	164
Table 91	Storage modes	165
Table 92	View storage status details.....	171
Table 93	Storage controls details.....	173
Table 94	View storage setting details.....	176
Table 95	Controller status details	180
Table 96	Set mode details.....	181
Table 97	Controller modes defined	181
Table 98	Set time and date details	182
Table 99	Set security details.....	183
Table 100	Displays and functions that can be secured	185
Table 101	Set language details	187
Table 102	COMM A status details - Model 551/552.....	189
Table 103	Set COMM A port details.....	190
Table 104	COMM B status details	191
Table 105	Set COMM B port details.....	192
Table 106	View slave devices details.....	193
Table 107	View slave devices details.....	194
Table 108	Communications menu details - Model 1041	196

Table 109	File name selection details.....	198
Table 110	Self tests details.....	199
Table 111	Calibrate AI channel details.....	202
Table 112	Calibrate CJ temp details.....	204
Table 113	Copy calibration details.....	206
Table 114	Restore AI factory calibration details.....	207
Table 115	Restore CJ factory calibration details.....	208
Table 116	Calibrate AO channel details.....	211
Table 117	Restore AO factory calibration details.....	212
Table 118	Parts.....	214
Table 119	Messages.....	217

Figures

Figure 1	551 operator interface	1
Figure 2	552 operator interface	1
Figure 3	1041 operator interface	1
Figure 4	Overview example of a UMC800 architecture	4
Figure 5	Cutout dimensions for bracket mounting	8
Figure 6	Mounting in a side enclosure	8
Figure 7	Panel mounting with brackets	9
Figure 8	Cutout for panel mounting with screws	10
Figure 9	Panel mounting with screws	11
Figure 10	Model 552 operator interface panel cutout	12
Figure 11	Model 1041 operator interface panel mounting dimensions	13
Figure 12	Terminal connections	15
Figure 13	Ferrite clamp installation	16
Figure 14	Startup display	17
Figure 15	View of a 551/552 operator interface	19
Figure 16	View of a 1041 operator interface	20
Figure 17	Model 551/552 Display key label dimensions	30
Figure 18	Model 1041 display key label dimensions	30
Figure 19	Display areas defined	31
Figure 20	Display organization	32
Figure 21	Main menu	39
Figure 22	Recipe edit	40
Figure 23	Alarm summary	43
Figure 24	Alarm group display	43
Figure 25	Alarm detail display	44
Figure 26	Event summary	44
Figure 27	Controller diagnostics	45
Figure 28	I/O module diagnostics	49
Figure 29	Panel diagnostic log	50
Figure 30	Clear diagnostic stripe	51
Figure 31	List disk files	54
Figure 32	Load/store profiles	55
Figure 33	Relationship between diskette, profile memory, and setpoint programmer	55
Figure 34	Load/store schedules	57
Figure 35	Load/store recipes	59
Figure 36	Load configuration	61
Figure 37	Store configuration	62
Figure 38	Format disk	63
Figure 39	Set mode	64
Figure 40	IMAN loop mode	67
Figure 41	Select loop	68
Figure 42	Loop menu display	69
Figure 43	Single loop trend	70
Figure 44	Loop auto tune display	71
Figure 45	Loop tune constants	72
Figure 46	Loop control setup	73
Figure 47	Carbon loop setup	75
Figure 48	Loop alarm setpoints	76
Figure 49	Loop limits	78
Figure 50	Eight loop summary	80
Figure 51	Sixteen loop summary	81
Figure 52	Loop control	82

Figure 53	8 loop faceplate	83
Figure 54	4 loop faceplate	84
Figure 55	3 loop faceplate	85
Figure 56	2 loop faceplate	86
Figure 57	Single loop numeric	87
Figure 58	Single loop faceplate with loop trend screen	88
Figure 59	Loop control display	89
Figure 60	Loop tune constants display	90
Figure 61	A/M bias	91
Figure 62	Select program	94
Figure 63	Edit program	95
Figure 64	Edit segment	97
Figure 65	Edit segment events	99
Figure 66	Save program	100
Figure 67	Example of saving a program	100
Figure 68	Single SPP operation - Model 551/552	102
Figure 69	Single SPP operation - Model 1041	104
Figure 70	Load program	106
Figure 71	Example of loading a program from a profile number	107
Figure 72	Example of loading a program from a profile list	107
Figure 73	SPP operate popup menu - Model 551/552 only	108
Figure 74	View program events - Model 551/552	109
Figure 75	View program details - Model 551/552	110
Figure 76	Edit segments	111
Figure 77	Edit schedule	115
Figure 78	Edit segment	116
Figure 79	Edit setpoints	117
Figure 80	Edit events	118
Figure 81	Edit guarantee hold	119
Figure 82	Save schedule	120
Figure 83	Example of saving a schedule	120
Figure 84	Edit guarantee hold limits	121
Figure 85	Setpoint schedule operation	124
Figure 86	Setpoint schedule operation - Model 1041	126
Figure 87	Load schedule	128
Figure 88	Example of loading a schedule from schedule number	129
Figure 89	Example of loading a schedule from schedule list	129
Figure 90	Scheduler operate popup menu	130
Figure 91	View schedule events	132
Figure 92	View auxiliary data	133
Figure 93	Edit segments	134
Figure 94	Alarm summary	137
Figure 95	Alarm group display	139
Figure 96	Pushbutton menu with function keys	141
Figure 97	Four selector switch display	142
Figure 98	Four selector switch popup menu	142
Figure 99	Device control display	143
Figure 100	Edit device display	144
Figure 101	Hand/Off/Auto switch display	145
Figure 102	Set HOA switch state display	145
Figure 103	Recipe load	147
Figure 104	Trend displays	150
Figure 105	Vertical trend at 2X zoom	153
Figure 106	Bar graph displays	154
Figure 107	Panel display	155

Figure 108	4-point panel display	156
Figure 109	Multi-point panel display	157
Figure 110	Panel meter	157
Figure 111	Overview	158
Figure 112	Help (messages) display	159
Figure 113	Data storage process	161
Figure 114	Required enabled controls for storage	166
Figure 115	Storage control menu with all enablers shown	167
Figure 116	Trend storage: enable conditions	168
Figure 117	Alarm/event storage: enable conditions	168
Figure 118	Point log storage: enable conditions	169
Figure 119	View storage status	171
Figure 120	Storage controls	173
Figure 121	Initialize storage disk	174
Figure 122	Load storage settings	175
Figure 123	View storage settings	176
Figure 124	Start new storage settings	177
Figure 125	Store storage settings	178
Figure 126	Controller status	180
Figure 127	Set mode	181
Figure 128	Set time and date	182
Figure 129	Set security/review security	183
Figure 130	Security access	184
Figure 131	Set language	187
Figure 132	Communications	188
Figure 133	COMM A status - Model 551/552	189
Figure 134	Set COMM A port	190
Figure 135	COMM B status	191
Figure 136	Set COMM B port	192
Figure 137	View slave devices	193
Figure 138	View slave device details	194
Figure 139	Communications menu - Model 1041	196
Figure 140	File name selection	198
Figure 141	Self tests	199
Figure 142	Calibrate AI	200
Figure 143	Set mode	201
Figure 144	Calibrate AI channel	201
Figure 145	Calibrate CJ temp	204
Figure 146	Copy calibration	206
Figure 147	Restore AI factory calibration	207
Figure 148	Restore CJ factory calibration	208
Figure 149	Calibrate AO	209
Figure 150	Set mode	210
Figure 151	Calibrate AO channel	210
Figure 152	Restore AO factory calibration	212
Figure 153	Brightness display	213
Figure 154	Remote operator interface connection	226

www.rgbautomatyka.pl

Introduction

Overview

What's in this guide

This guide contains instructions on assembly, installation, wiring, and operation of the 551, 552, and 1041 Series Operator Interface, shown in Figure 1, Figure 2 and Figure 3.

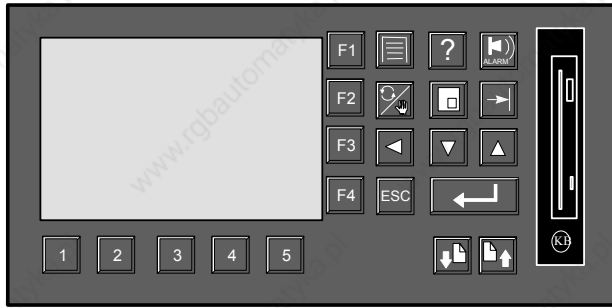

Figure 1 551 operator interface

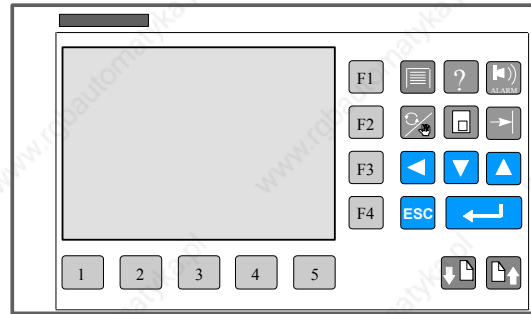

Figure 2 552 operator interface

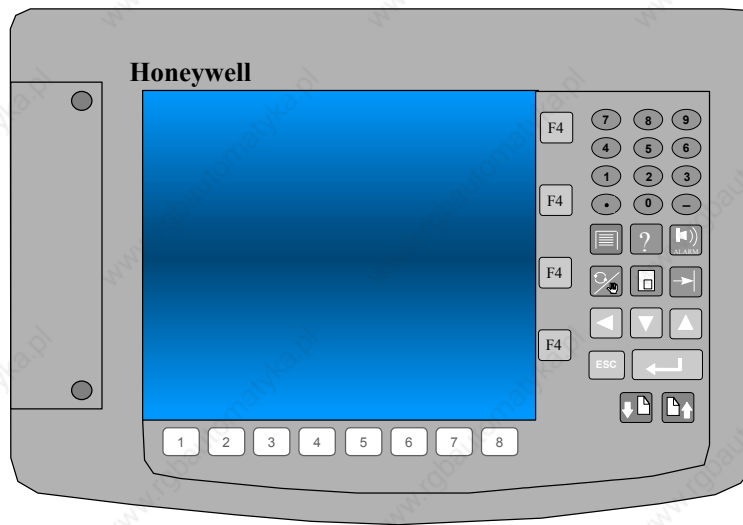

Figure 3 1041 operator interface

Typical readers of this guide

The typical users of this guide are:

- the technician who installs the Operator Interface,
- the engineer who configures the Operator Interface.

What you can do with the operator interface

The Operator Interface lets you perform these tasks:

- Monitor and control a process.
- Load/Store/Run Recipes, Profiles, Schedules, and Unit Configurations.
- Display various process data such as trends, alarms, diagnostics, setpoint profiles, and control loops.

CE Conformity

This product is in conformity with the protection requirements of the following European Council Directives: **73/23/EEC**, the Low Voltage Directive, and **89/336/EEC**, the EMC Directive. Conformity of this product with any other “CE Mark” Directive(s) shall not be assumed.



ATTENTION

The emission limits of EN 50081-2 are designed to provide reasonable protection against harmful interference when this equipment is operated in an industrial environment. Operation of this equipment in a residential area may cause harmful interference. This equipment generates, uses, and can radiate radio frequency energy and may cause interference to radio and television reception when the equipment is used closer than 30 meters to the antenna(e). In special cases, when highly susceptible apparatus is used in close proximity, the user may have to employ additional mitigating measures to further reduce the electromagnetic emissions of this equipment.

Overview of Architecture

Description of Components

The Operator Interface is one of three components of a control system that contains:

- **Controller Module** - As the heart of the system, this supports the following features.
 - 2 to 16 control loops
 - 4 to 64 analog inputs
 - 0 to 16 analog outputs
 - 0 to 96 Local Digital I/O
 - setpoint programming
 - setpoint scheduler
 - recipe management
 - start/stop controls
 - function blocks
 - fast (100 ms) logic.
- **Control Builder** - An external PC based configuration tool that is used to graphically configure the control strategies used by the Controller Module. It is also used to configure displays and function keys on the Operator Interface. Control strategy configurations are downloaded from Control Builder to the Controller Module through communications or are loaded with an optional floppy drive on the Operator Interface.
- **Operator Interface** - Provides the operator interface for the Controller Module. It lets the operator
 - operate the process through various menus and displays,
 - monitor the process with trends and other graphical displays,
 - view and acknowledge alarm annunciation.

See Figure 4.

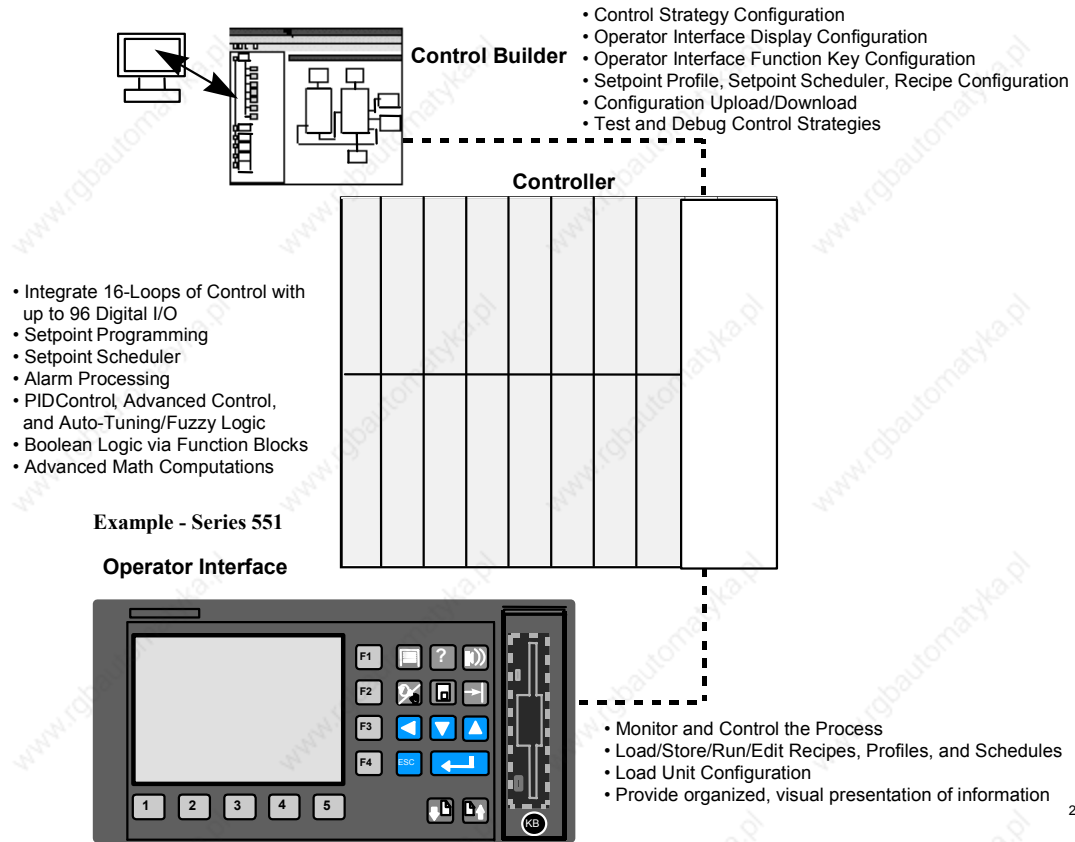

24216

Figure 4 Overview example of a UMC800 architecture

Specifications/Mounting/Wiring/Startup

Specifications

Table 1 Specifications

Design	
CE Conformity	This product is in conformity with the protection requirements of the following European Council Directives: 73/23/EEC, the Low Voltage Directive, and 89/336/EEC, the EMC Directive. Conformity of this product with any other "CE Mark" Directive(s) shall not be assumed.
Installation Category (Overvoltage Category)	Category II (EN 61010-1)
Pollution Degree	Pollution Degree 2 (ref. IEC 664-1)
EMC Classification	Group 1, Class A, ISM Equipment, Industrial Equipment (EN 61326 emissions, immunity)
Operator Interface Components	<p>Model 551/552 includes a Passive color LCD, 320 x 240 pixels (¼ VGA), full-function front panel keys, optional 3.5" 1.44 MB diskette for file load and store functions, data storage, and an optional QWERTY keyboard port.</p> <p>Model 1041 includes a TFT Active Matrix Color LCD, 640 x 480 pixels (Std VGA), full-function front panel keys, standard 3.5" 1.44 MB diskette or an optional 120 mb Zip Drive for file load and store functions, data storage, and an optional QWERTY keyboard port.</p> <p>The operator interface software provides a view into the controller, and allows the user to monitor and control the process through predefined screens.</p>
Power	Operator interface power is supplied from the controller through the interface cable/connectors. 24 Vdc ± 10% @ 1.3 Amps
Enclosure	<p>Material:</p> <p><i>Model 551:</i> Structural Foam (Glass filled polycarbonate, UL 94V-1) <i>Model 552:</i> 304 StainlessSteel <i>Model 1041:</i> Bezel - 20 % glass filled polycarbonate (GE Lexan 3412R) Chassis - Zinc plated steel with Yellow Chromate coating</p> <p>Dimensions:</p> <p><i>Model 551</i> Inches: 11.3 wide x 5.7 high x 5.4 deep Millimeters: 288 wide x 144 high x 136 deep</p> <p><i>Model 552</i> Inches: 9.4 wide x 6.25 high x 5.8 deep Millimeters: 240 wide x 159 high x 148 deep</p> <p><i>Model 1041</i> Inches: 15.8 wide x 9.8 high x 7.2 deep Millimeters: 400 wide x 248 high x 183 deep</p>
System Interconnection	Connected to controller through its dedicated RS422 port. <i>Maximum Distance Between Controller and Operator Interface:</i> 15 meters (50 feet.) <i>Cable Type:</i> 15 conductor, shielded <i>Cable termination:</i> 15-pin "D" connector at the controller end; screw type terminal strip required at operator interface end

Performance	<p><i>Average Screen Update Rate:</i> 1.0 seconds <i>Average Data Entry Response Time:</i> 1.5 seconds <i>Average Screen Call-up Time:</i> 1.5 seconds</p>		
Product Classification	<p>Class I: Fixed, Permanently Connected, Industrial Control Equipment with protective earthing (grounding). (EN 61010-1)</p>		
Mounting	<p>551 Type 12: DIN (288 x 144) compatible panel mounted. May be panel mounted (IP 54, NEMA 12) in indoor non-hazardous locations. 552 Type 4x: Panel mounted only Model 1041: Panel Mounted only</p>		
Display	<p>Model 551/552 <i>Type:</i> Color (passive LCD), 320 x 240 pixels resolution <i>Viewing Area:</i> 119 mm wide x 90 mm high (4.7 inches wide x 3.5 inches high) Model 1041 <i>Type:</i> TFT Active Matrix Color CD, 640 x 480 pixels resolution <i>Viewing Area:</i> 211 mm wide x 158 mm high (8.3 inches wide x 6.2 inches high)</p>		
Back-Light	<p>Cold Cathode Fluorescent Lamp (CFL) 10K Hours to half brightness</p>		
Front Panel	<p>Model 551/552 <i>Keys:</i> Membrane—22 keys <i>Keyboard:</i> Plug-in connector with front access (optional rear access on 552 Type 4x model) Model 1041 <i>Keys:</i> Membrane—37 keys <i>Keyboard:</i> Plug-in connector with rear access</p>		
Disk Drive	<p><i>Format:</i> 3.5 inch, 1.44 megabytes Model 551/552: Optional Model 1041: Standard (120mb Zip Drive is optional)</p>		
Certifications	<p>Model 551 Type 12 CSA C22.2 No. 1010-1, Safety Requirements for Electrical Equipment for Measurement, Control, and Laboratory Equipment, Part 1: General Requirements. UL 1092/UL 916, Process Control Equipment Model 1041 CSA C22.2-1010.1, Safety Requirements for Electrical Equipment for Measurement, Control, and Laboratory Equipment, Part 1: General Requirements UL3121-1</p>		
Environmental Conditions			
	Model 551	Model 552	Model 1041
Ambient Operating Temperature	32 °F to 122 °F 0 °C to 50 °C	41 °F to 126 °F 5 °C to 52 °C	32 °F to 113 °F 0 °C to 45 °C (ZIP Option)
Ambient Storage Temperature	-4 °F to 140 °F -20 °C to 60 °C	-4 °F to 140 °F -20 °C to 60 °C	-4 °F to 140 °F -20 °C to 60 °C
Ambient Operating Relative Humidity	10 % to 90 % RH non-condensing	10 % to 90 % RH non-condensing	20 % to 80 % RH non-condensing
Ambient Storage Relative Humidity	5 % to 95 % RH non-condensing	5 % to 95 % RH non-condensing	5 % to 90 % RH non-condensing

Specifications are subject to change without notice.

Site Preparation

The cable that connects the Operator Interface to the controller module contains low voltages. Keep the cable away from high voltage wires that can cause interference.

Operator Interface Mounting

The Operator Interface comes available in three models: Model 551 (type 12 enclosure), Model 552 (type 4 enclosure), and Model 1041. Refer to the section for your model.

Model 551

The 551 Operator Interface case can be mounted the following ways.

- Panel-mounted using brackets
- Panel-mounted using screws

Whichever mounting method you choose, the supplied mounting kit contains the following hardware to secure the Operator Interface case.

Part	Quantity
M6 Lock washer	2
M6 x 8 mm/0.312" long hex head screw	2
12.7 mm/0.500" long Plastite #6 screw	4
8 mm/0.312" long Plastite #6 screw	4
Mounting bracket	2

Procedures for each mounting method are given below.

Panel mounting with brackets

The 551 Operator Interface case can be flush mounted in a cutout and secured using brackets supplied with the mounting kit.

Step	Action
1	At the appropriate mounting location, make a rectangular cutout in the panel measuring 10.625 ± 0.030 inches by 5.190 ± 0.030 inches (269.875 ± 0.76 by 131.825 ± 0.76 millimeters). See Figure 5. If you are mounting the Operator Interface to a side enclosure as in Figure 6, make sure the cutout allows for clearance from the enclosure's internal panel. The left side of the rear of the Operator Interface is offset to the right to accommodate that internal panel.
2	Orient the Operator Interface properly and slide it into the cutout from the front of the panel. Support the panel as shown in steps 3 and 4.
3	Refer to Figure 7. From the back of the panel, attach a mounting bracket to the top and bottom of the interface case. Insert the provided M6 hex head screw and lock washer through the slotted hole in each bracket. Leave the screws slightly loose so you can adjust the brackets.

Step	Action
4	While holding the Operator Interface firmly against the panel, slide each bracket against the back of the panel and tighten the screws.

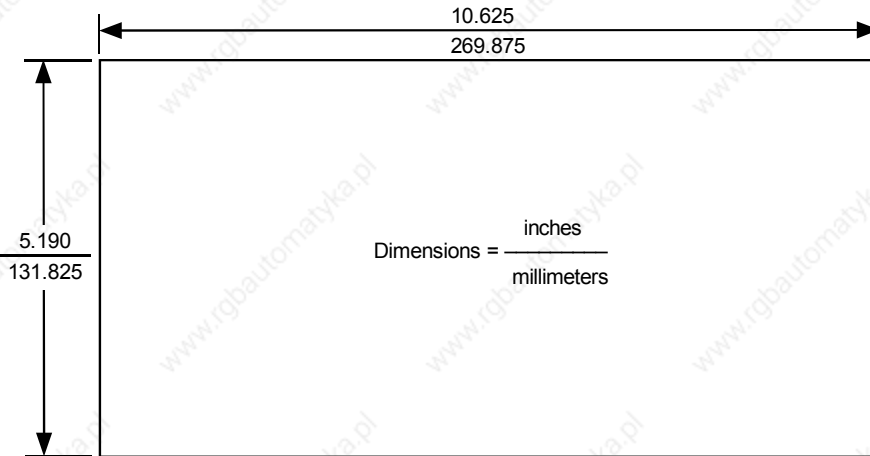

Figure 5 Cutout dimensions for bracket mounting

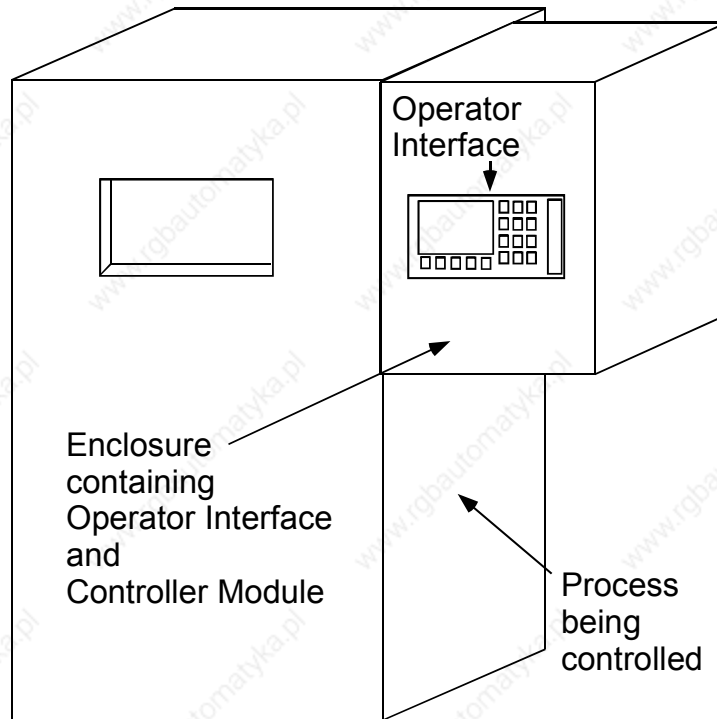

Figure 6 Mounting in a side enclosure

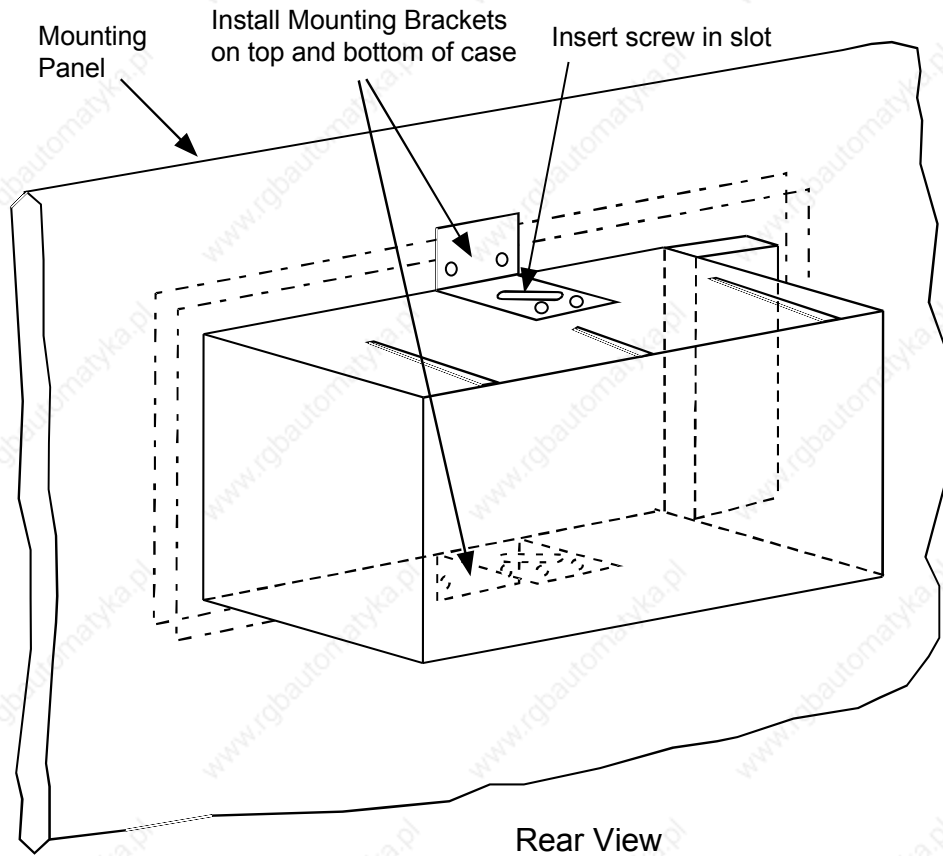

Figure 7 Panel mounting with brackets

Panel mounting with screws

The 551 Operator Interface can also be panel mounted using screws.



ATTENTION

Make sure you have a clearance of at least 5.35 inches (135.9 millimeters) behind the panel to accommodate the case of the Model 551 Operator Interface.

Step	Action
1	At the appropriate mounting location, make a rectangular cutout in the panel measuring 10.625 ± 0.030 inches by 5.190 ± 0.030 inches (269.875 ± 0.76 by 131.825 ± 0.76 millimeters). See Figure 8.
2	Measure and make four cutouts in the panel to accommodate the mounting screws. Refer to Figure 9 for dimensions.
3	Orient the Operator Interface properly and slide it into the cutout from the front of the panel. See Figure 9.

Step	Action
4	<p>Orient the Operator Interface case against the mounting surface and attach using 4 screws from the rear.</p> <p>For panels up to 3 mm (0.125") thick, use 9.5 mm (0.375") long Plastite screws provided.</p> <p>For panels 3 mm (0.125") to 6.4 mm (0.25") thick, use 12.5 mm (0.5") long Plastite screws provided.</p> <p>For panels greater than 6.4 mm (0.25") thick, tap the case holes with M3.5 or #6-32 threads and use screws of appropriate length.</p>
5	Position the Operator Interface firmly against the panel and tighten the screws.

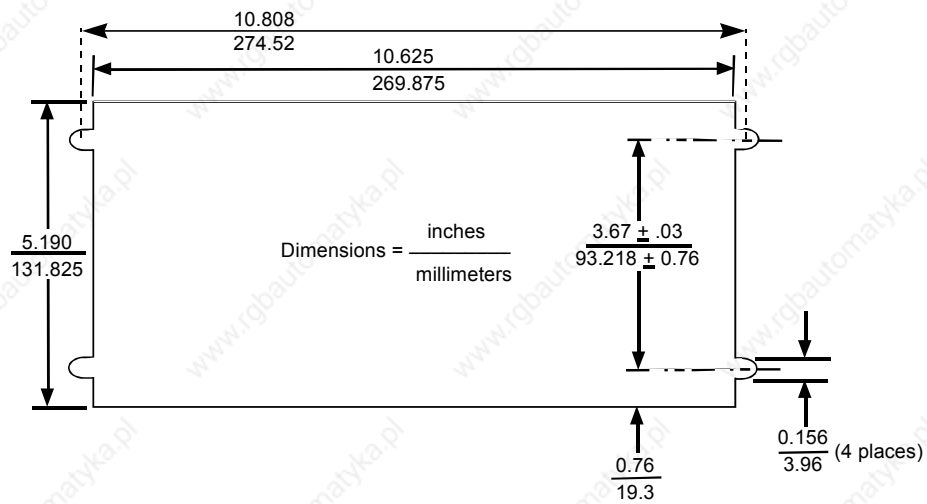

Figure 8 Cutout for panel mounting with screws

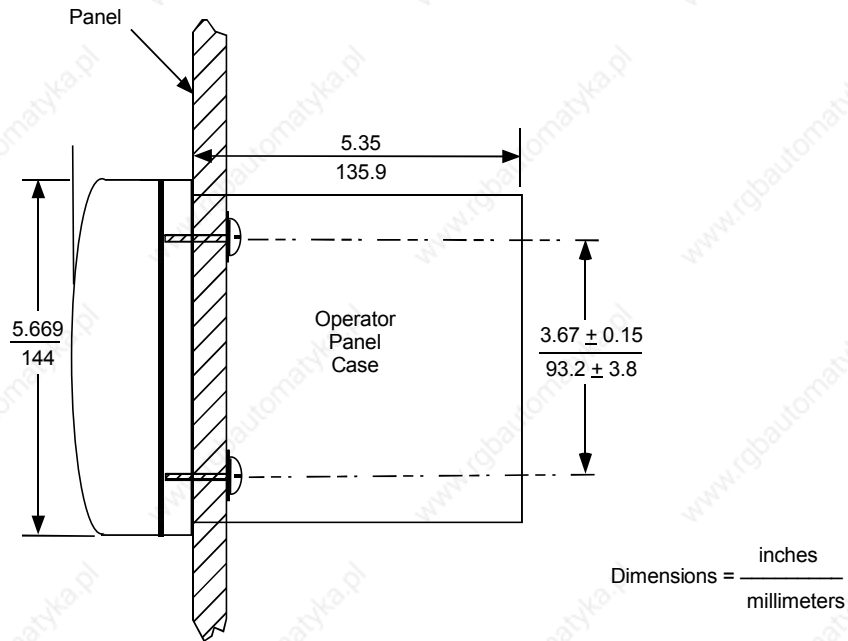

Figure 9 Panel mounting with screws

Model 552

The 552 Operator Interface must be panel mounted using the supplied hardware.



ATTENTION

Make sure you have a clearance of at least 5.5 inches (140 millimeters) behind the panel to accommodate the case of the Model 552 Operator Interface.

Step	Action
1	If installing new button label below the display, do so now before continuing this procedure. See Relabeling Display Group Keys (page 29) for details.
2	See Figure 10. Make a cutout in the panel as shown. Drill 12 holes as shown.
3	Install gasket over the 12 threaded studs on the front.
4	Install spacers on each of the 12 studs. If there are 14 spacers, install one per stud. If there are 26 spacers, install 2 per stud.
5	Insert Operator Interface into the panel, left side (latch side) first.
6	Have a helper hold the unit snugly against the panel. Attach the 12 nuts to the 12 threaded studs.
7	Tighten nuts to 12 inch-lbs. (1 ft.-lb.)

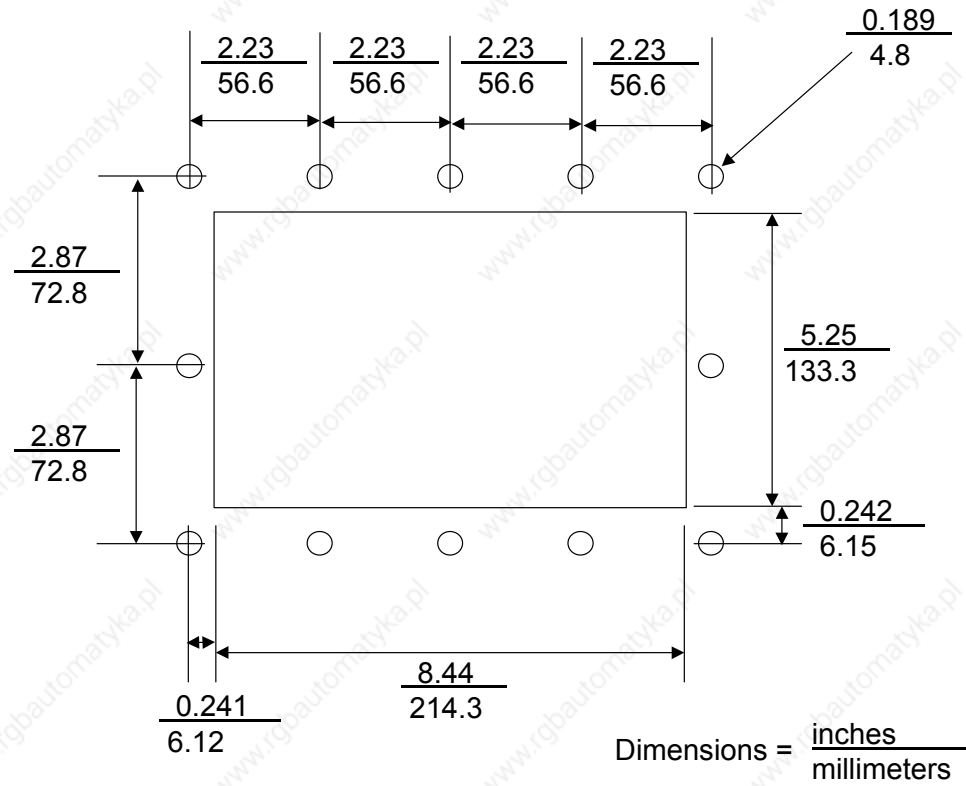

Figure 10 Model 552 operator interface panel cutout

Model 1041

The 1041 Operator Interface case can be panel mounted using the supplied clamps.



ATTENTION

Make sure you have a clearance of at least 7.2 inches (183 millimeters) behind the panel to accommodate the case of the Model 1041 Operator Interface.

Step	Action
1	If installing new button label below the display, do so now before continuing this procedure. See <i>Relabeling Display Group Keys (page 29)</i> for details.
2	See Figure 11. Make a cutout in the panel using dimensions shown.
3	Carefully assemble the gasket into the groove molded into the back of the bezel. The adhesive side should contact the bezel.
4	Insert Operator Interface into the panel. Have a helper hold the unit snugly against the panel.
5	Attach the 18 mounting screws as shown in Figure 11. Tighten the screws against the panel thereby compressing the foam gasket. Continue tightening until the back of the plastic bezel just makes contact with the panel..

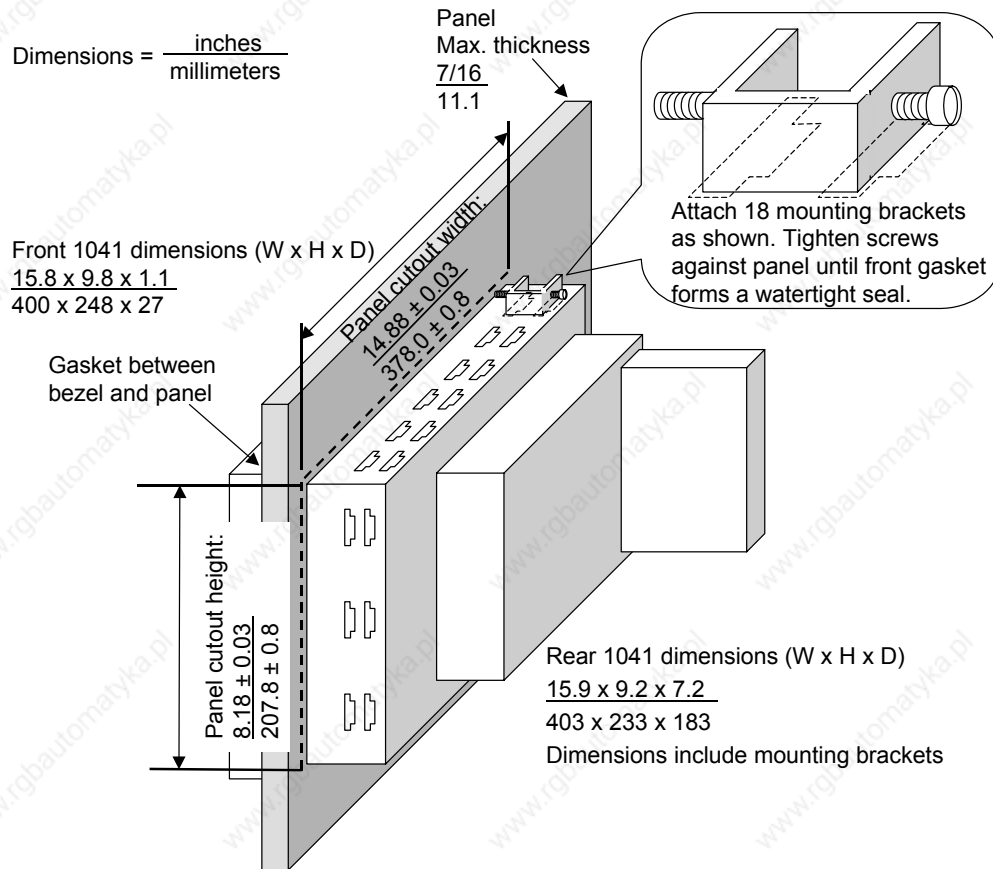

Figure 11 Model 1041 operator interface panel mounting dimensions

Cable Connections

Description

The cable that connects the UMC800 Controller to the Operator Interface is either 10' (3.05 m) or 50' (15.42 m) long. It is shielded to protect from noise.

Connecting the cable



Step	Action
1	Prepare the cable end for connection by removing about 3" (7.5 cm) of the outer PVC jacket. Do not cut into the wires within.
2	Notice the tinned copper braid outer shield surrounding the wires. Beneath it notice the foil surrounding all the wires. Gather this outer wire braid to one side and twist it so it forms its own wire separate from the other wires.
3	Remove the foil back to the jacket. Notice the 4 groups of 3 wires. Each group consists of a colored wire, a black wire, and a bare drain wire for the foil shield.
4	Remove the foil from the black/white wires and shield. Remove about 0.5" (1.2 cm) of insulation from both wires.
5	Connect the terminal block to the rear of the Operator Interface. Use the terminal block label to locate terminal #1 (at top on 551 and 1041 models, at bottom on 552 model). At the rear of the Operator Interface, connect the black wire to terminal #1. Connect the white wire to terminal #2. Connect the inner shield drain wire to terminal #3.
	CAUTION: The black wires in each twisted pair are not common circuits. Misconnecting the black wires may damage the equipment.
6	Remove the foil from the black/red wires and shield. Remove about 0.5" (1.2 cm) of insulation from both wires.
7	Connect the black wire from this pair to terminal #4. Connect the red wire to terminal #5. Connect the inner shield drain wire to terminal #3 along with the other inner shield from the black/white wires.
8	Remove the foil from the black/green wires and shield. Remove about 0.5" (1.2 cm) of insulation from both wires. The inner shield drain wire will not be used, so cut it off.
9	Connect both the black and green wires to terminal #6.
10	Connect the outer shield braid (from step 2) to terminal #7. Note: For proper operation keep the inner drain wires separated from the outer shield.
11	Remove the foil from the black/blue wires and shield. Remove about 0.5" (1.2 cm) of insulation from both wires. The inner shield drain wire will not be used, so cut it off.
12	Connect the black wire from this pair to terminal #9. Connect the blue wire to terminal #10.
	CAUTION: For 24 Vdc, make sure that the wiring is on terminals #9 and #10 . The CPU board may be damaged if the wiring is accidentally connected to terminals #1 and #2.

Table 2 Terminal assignments

Signal Name	Wire Color	Terminal No.
Receive -	Black	1
Receive +	White	2
Receive Shield	Shield (bare drain wire grouped with black/white pair)	3
Transmit Shield	Shield (bare drain wire grouped with black/red pair)	3
Transmit -	Black	4
Transmit +	Red	5
24VDC Return	Black	6
24VDC Return	Green	6
Outer Shield	Shield (tinned wire braid enclosing all 4 pairs)	7
Unused	Unused	8
+24 Vdc	Black*	9
+24 Vdc	Blue*	10

* For 24 Vdc, make sure that **the wiring is on terminals #9 and #10**. The CPU board may be damaged if the wiring is accidentally connected to terminals #1 and #2.

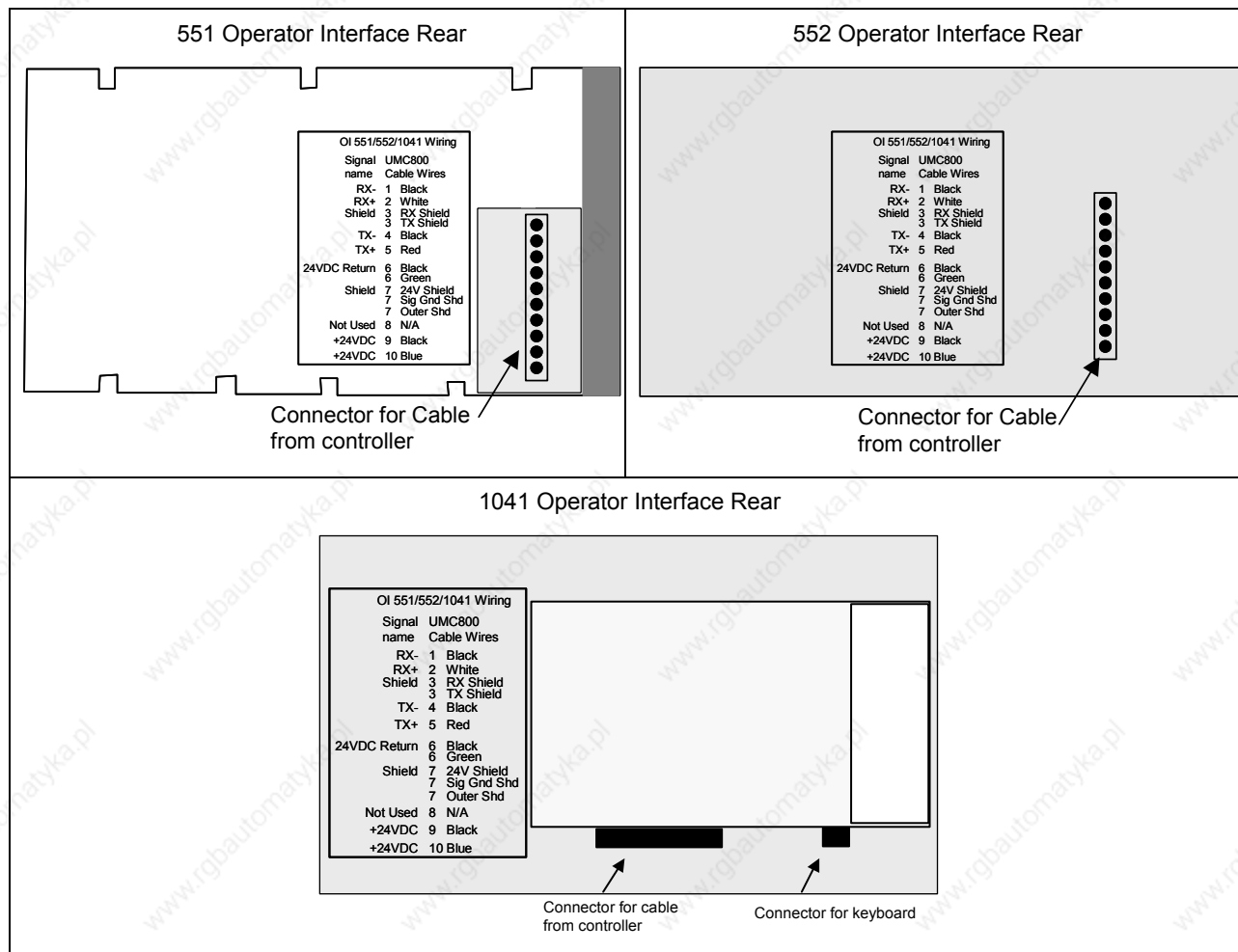

Figure 12 Terminal connections

Noise Protection

See document 51-52-05-01, *How to Apply Digital Instrumentation in Severe Electrical Noise Environments*.

Installing Ferrite Clamp for CE Compliance

This procedure ensures that unwanted radio frequency noise is filtered. It is required for CE compliance.

Parts needed

Part #	Quantity	Description
047260	1	Ferrite cable clamps
089037	2	Nylon cable ties

Installing ferrite clamp

Step	Action
1	Disconnect all power to the instrument.
2	See Figure 13. Attach the ferrite clamp around all the wires as close to the instrument's terminals as possible (within ½" of the terminals). For maximum shielding you must minimize the amount of unshielded exposed wire. The ferrite clamp should overlap or abut the cable shield enclosing the wires.
3	Snap the ferrite clamp closed, making sure to not pinch the wires.
4	To prevent the ferrite clamp from sliding, attach cable ties around the wires snugly against each end of the ferrite clamp.
5	Trim the cable tie but leave a "tail" of approximately 1".

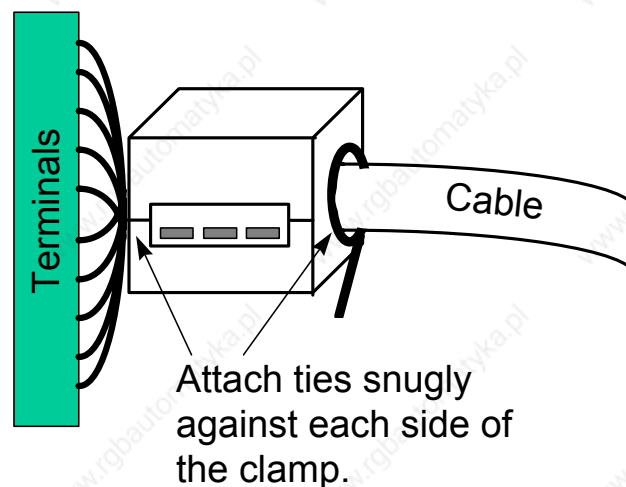

Figure 13 Ferrite clamp installation

Startup

After connecting the Controller and Operator Interface and applying power to the Controller, the startup display appears.

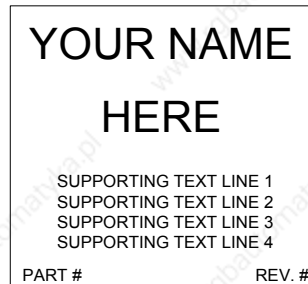



Figure 14 Startup display

What to do if the instrument has difficulty starting up

During power up the instrument may get stuck in a cycle of alternating between the startup screen and shutting down. This problem may be caused by a weak capacitor or it may occur after power has been disconnected for an unusually long time. “Long time” depends on the condition of the capacitor, the ambient temperature, or other factors. To correct this problem you must manually perform a “cold start.” A cold start clears the Operator Interface memory.

Performing a cold start

Step	Action
1	Turn the instrument's power off.
2	Press and hold the ESC key.
3	<p>While holding the ESC key turn the instrument's power on. The startup screen should appear normally.</p> <p> ATTENTION</p> <p>If the Operator Interface has been OFF for more than 18 hours, the default start-up screen will display instead of the user-configured text until communications has started to the controller and the user-configured text is uploaded.</p>

Keys and Displays Overview

Overview of Keys

The Operator Interface (Figure 15) and (Figure 16) consists of standard and custom keys, an optional floppy drive (standard for Model 1041 with optional Zip Drive) for storing and loading data, and an optional keyboard connector for data entry through an AT keyboard.

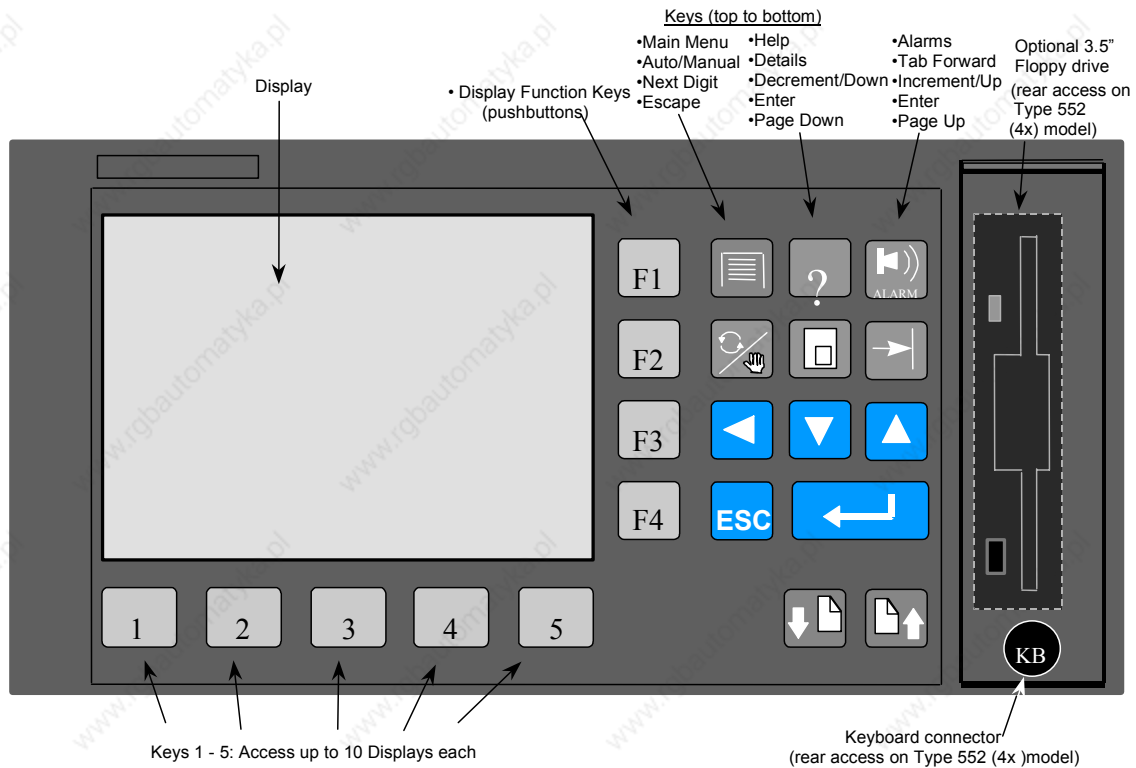

Figure 15 View of a 551/552 operator interface

You can attach an AT keyboard to the front for easier data entry. Simply plug the keyboard into the port under the floppy drive. See Table 3 for key equivalents.

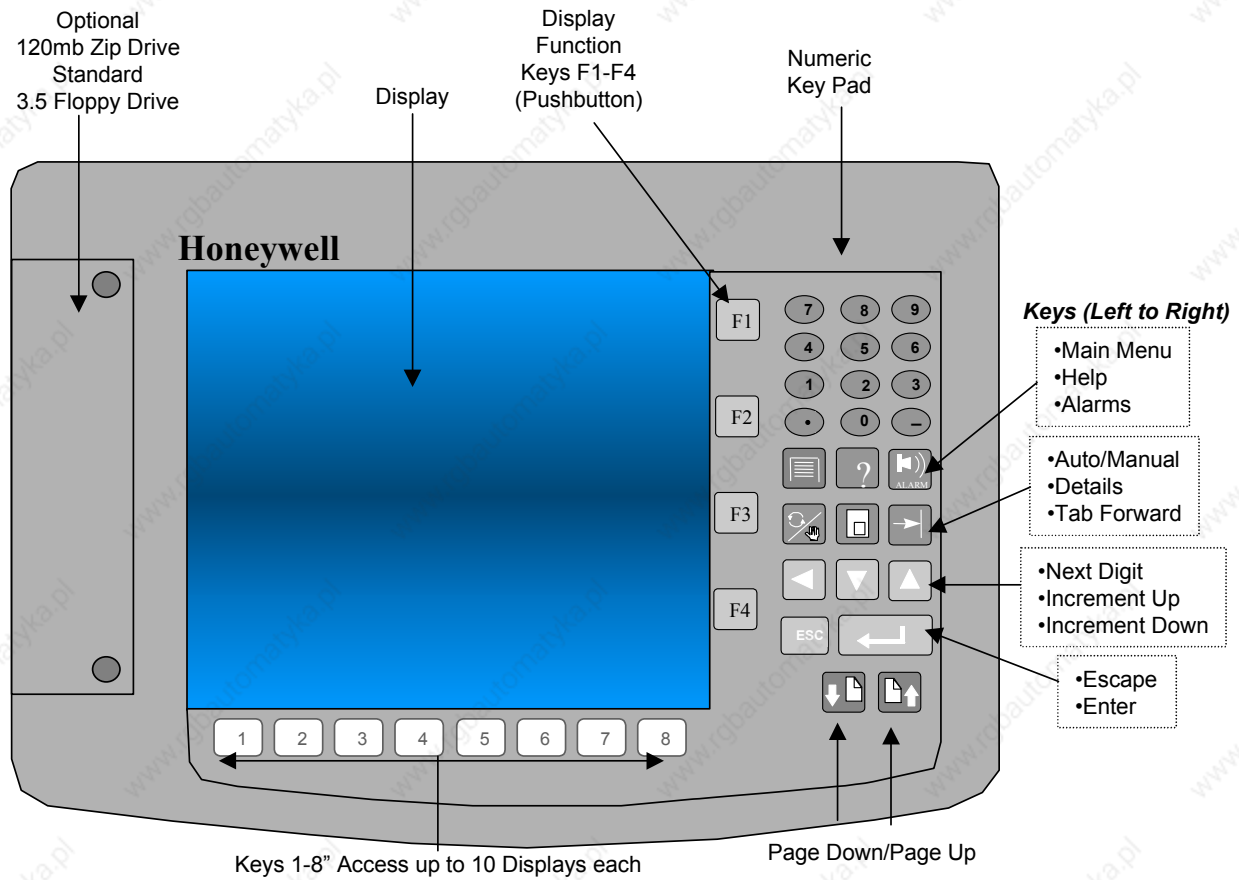

Figure 16 View of a 1041 operator interface

You can attach an AT keyboard to the rear of Model 1041 for easier data entry. Simply plug the keyboard into the port. See Table 3 for key equivalents.









Standard Keys

Overview







The appearance and action of the 13 standard keys (plus 0 to 9 numeric on Model 1041) are given in Table 3. Refer to this table for direction with any display. Unless otherwise noted, standard keys always behave as described here regardless of which display or menu is displayed.

You can attach an AT keyboard for easier data entry. Simply plug the keyboard into the port. See Table 3.

Table 3 Standard key actions

Key	Key Name	AT keyboard equivalent	Action
	Menu	Home	<ul style="list-style-type: none"> Accesses the Main Menu. See <i>Overview of Displays (page 31)</i>.
	Help	End	<ul style="list-style-type: none"> Accesses the Help Text Displays, which contain help on various procedures. See <i>Other Displays (page 159)</i>.
	Alarm	F3	<ul style="list-style-type: none"> Accesses the Alarm Summary. From the Alarm Group Display, this key acknowledges all alarms on the page. See <i>Alarm Group (page 139)</i>.
	Auto/Manual	F2	<ul style="list-style-type: none"> On a loop display, toggles the selected loop between Automatic and Manual modes.
	Detail	F1	<ul style="list-style-type: none"> On Loop displays, moves cursor to SP and Output. On Trend and Panel Displays, accesses a submenu containing further detailed functions. On Alarm Group display, moves cursor down a column.
	Tab	Tab	<ul style="list-style-type: none"> On multiple Loop displays, moves cursor between the loop tags on the display. Press Enter to access a more detailed display related to the selected loop tag. On Alarm Group display, moves cursor across a row.
	Left Arrow	←	<ul style="list-style-type: none"> When cursor is on a value or setting that can be changed, this key moves cursor one position to the left, eventually wrapping around to the rightmost position.
	Decrement	↓	<ul style="list-style-type: none"> Moves cursor down a menu or list of choices. Selecting down on the last menu item sets the focus on the <i>first</i> menu item. When cursor is on a data entry field, decrements value or state. On a trend display, scrolls trend backward in time.











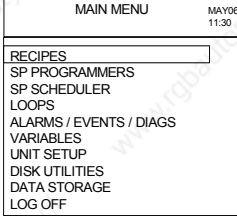



Keys and Displays Overview
Standard Keys

Key	Key Name	AT keyboard equivalent	Action
	Increment	↑	<ul style="list-style-type: none"> Moves cursor up a menu or list of choices. Selecting up on the first menu item sets the focus on the <i>last</i> menu item. On a selected data entry field, increments value or state. On a trend display, scrolls trend forward in time.
	Escape	Esc	<ul style="list-style-type: none"> On all menus and displays, escapes from the current cursor location or display or menu and returns you to the previous one. Any data entered or changes you made are not saved, except changes to a loop's live values (output, setpoint value).
	Enter	Enter ↵	<ul style="list-style-type: none"> On all menus and displays, selects the field highlighted by the green cursor, taking you to another display or enabling you to change the field's value or setting. Saves a new value or setting.
	Page Down	Page Down	<ul style="list-style-type: none"> Accesses the next page of a multi-page display. Accesses the next display in the sequence of the Display key.
	Page Up	Page Up	<ul style="list-style-type: none"> Accesses the previous page of a multi-page display. Accesses the previous display in the sequence of the Display key.
 thru 	Numeric Model 1041 only	0 thru 9	<ul style="list-style-type: none"> Facilitates easy data entry for variables, setpoint programs, and other numeric set up parameters Also includes a "Decimal Point" key and a "Negative Sign" key.



Tasks Using Standard Keys







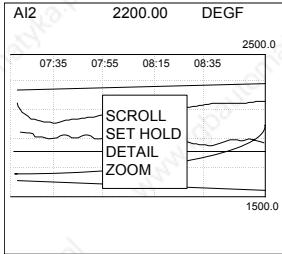

The following table describes all the ways you will typically use standard keys to interact with the Operator Interface. Unless otherwise noted, you can perform these tasks on any menu or display.

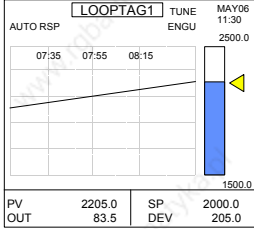
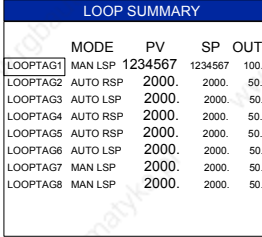
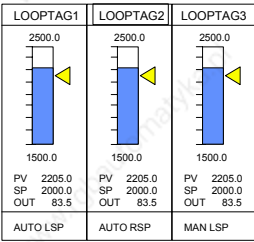
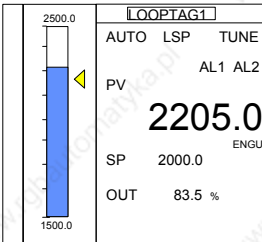
Table 4 Tasks using standard keys





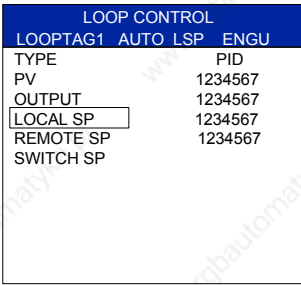

Task	Procedure
1. To see the Main Menu	<p>Press Menu  to get this:</p> 
2. To move the cursor up or down any menu or list	<p>Press Increment  or Decrement .</p> <p>Menu wrap is enabled for menus that do not scroll and disabled for scrolling menus.</p>
3. To see helpful text	<p>Press Help .</p>
4. To select a menu item to view its submenu or choices or value	<p>With the cursor on the desired item, press Enter .</p> <p>The submenu appears, or the cursor moves to the right side of the display so you can select another choice or value.</p>
5. To change a menu item's value or setting	<p>Model 551/552 With the cursor on the value or setting on the right side of the display, press Increment  and Decrement  to change a digit's value or to see other choices. Press  to move to another digit in the value.</p> <p>Model 1041 Use the numeric keys  thru , located in the upper right corner of the operator interface, to manually enter a value.</p> <p>The new value or setting does not take effect until you press Enter . If you change your mind and decide to leave the value or setting unchanged, press Escape .</p>
6. To manually change a control loop's output or setpoint value	<p>Same as Task 5, except changes to these values are done "live" so you do not have to press Enter  to accept the value. Also, changes cannot be canceled with Escape .</p>
7. To toggle a loop between AUTO and MANUAL	<p>Press Auto/Manual .</p>

Keys and Displays Overview
 Tasks Using Standard Keys

Task	Procedure
8. To ignore changes you made or are about to make to a value or setting	Press Escape  . The cursor moves from the right to the left side of the display, and the value or setting remains unchanged.
9. To back out of a display or menu or to return to a previous display or menu item	Press Escape  .
10. To see a detailed popup menu related to an operating or monitoring display (such as a trend). (An operating or monitoring display is accessed by pressing one of the keys below the display. See <i>Other Operating Displays</i> section and <i>Monitoring Displays</i> section.)	Press Detail  . 

Task	Procedure
<p>11. To adjust a loop's setpoint, output, or switch between Local and Remote setpoints</p>	<p>Access one of the following displays:</p> <p><i>Loop Trend:</i></p>  <p><i>Loop Summary:</i></p>  <p><i>2, 3, 4, or 8 Multi-Loop Faceplates:</i></p>  <p><i>Single Loop Numeric:</i></p>  <p>Notice these displays have a cursor around the loop tag at the top of the display. Press Tab  to move cursor to the desired loop tag. Press Detail  to move between the loop tag, SP value, and Output value (if in Manual). Adjust values as in Task #5 of this table. Note: you do not have to press Enter  to enter the values; they take effect instantly. Also, you can not cancel the changes by pressing Escape .</p> <p>With cursor on the loop tag, press Enter  to jump to that loop's control screen:</p>  <p>See <i>Loop control</i> (page 82).</p>
<p>12. To see an overview list of alarms</p>	<p>Press Alarm </p>

Keys and Displays Overview
 Tasks Using Standard Keys

Task	Procedure
13. To acknowledge all alarms in the currently displayed group of alarms (up to 12 alarms)	Press Alarm 
14. To see other operating and monitoring displays	Up to 10 displays can be assigned to each Display Group key. After pressing one of the five keys directly beneath the display, press Page Up  and Page Down  to see other displays assigned to that key.
15. To scroll backward and forward in time through vertical or horizontal trends	With a trend display, press Increment  or Decrement  . Or, press Detail  to show the popup menu. For other trend actions, see <i>Trend Displays (page 150)</i> .

User-assignable Keys

The function and factory-shipped appearance of the 12 user-assignable keys is described in Table 5. A display group key's appearance can be changed [see *Relabeling Display Group Keys (page 29)*] so its appearance may vary from Table 5 and Figure 15 and Figure 16. Specific functions of these keys are programmed with the Control Builder, a tool for configuring the instrument for its end user.

Keys F1-F4

The keys **F1-F4** function together with certain user-assignable displays and for the Single Setpoint Program or Setpoint Scheduler Operation display. For all other displays these keys are inactive.













The use of the F1 - F4 keys are discussed throughout the manual for the displays in which they are used.

Display keys 1-5 (Model 1041, keys 1- 8)

Display Keys **1-5 (8)** are programmed to access operating and monitoring displays. The five (eight) display groups keys (located below the display) each let you access up to ten operating and monitoring displays. Refer to *Other Operating Displays* section and *Monitoring Displays* section for descriptions and tasks related to these displays.

Task	Procedure
To see the last display shown from this group	Press the desired Display Group key.
To see the next or previous display assigned to a key	Press Page Down or Page Up.

Table 5 User-assignable key actions

Key	Key Name	AT keyboard equivalent	Action
	Pushbutton 1	F5	The use of the F1 - F4 keys are discussed throughout the manual for the displays in which they are used.
	Pushbutton 2	F6	
	Pushbutton 3	F7	
	Pushbutton 4	F8	
	Display Group 1	F9	Each Display group key displays the last display shown from a group of up to ten pre-configured operating and monitoring displays. Press Page Up or Page Down to show the next display in the key's sequence, eventually wrapping around to the first display.
	Display Group 2	F10	
	Display Group 3	F11	
	Display Group 4	F12	
	Display Group 5	F4	
	Display Group 6	Shift + F10	
	Display Group 7	Shift + F11	
	Display Group 8	Shift + F12	

Relabeling Display Group Keys

You may customize the appearance of the display group keys [1-5 (8)] by giving them more relevant names or labels for your application. For example, if you have configured Display Group #1 key to show all the Loop displays, you could replace the label with a more appropriate label like LOOPS.

Step	Action
1	<i>All models:</i> Disconnect power or disconnect the cable from the rear of the Operator Interface.
2	<i>551 model:</i> Unscrew the bolts under the floppy drive cover on the right front. <i>552 model:</i> Remove the 4 screws on the left and right sides of the unit. <i>1041 model:</i> Remove the 4 screws on the rear of the unit.
3	<i>551 model:</i> Pry off the right side of the front, towards you, as if opening a door. The left side will remain engaged on hinge-like appendages. <i>552 model:</i> Carefully remove the front without breaking the wire cable connection. <i>1041 model:</i> Carefully remove the front without breaking the wire cable connection.
4	<i>551 model:</i> Disengage the left side by pulling the front out and to the right. Be careful not to stretch or break attached wires and cables.
5	<i>All models:</i> Disconnect all wires and cables connected to the front.
6	<i>All models:</i> Looking at the rear of the front you just removed, notice the slots containing the labels for the keys. Remove the labels by pulling them out.
7	<i>All models:</i> Create new label strips from clear or white plastic. Most word processors on a personal computer let you create custom documents. Use the dimensions shown in Figure 17 and Figure 18 and keep text or symbols within the boxes shown. Round off the corners of the strip to allow easy insertion.
8	<i>All models:</i> To replace the labels, reverse steps 1 through 6. If you have difficulty inserting the new label, try gripping it with needle nose pliers and inserting it.

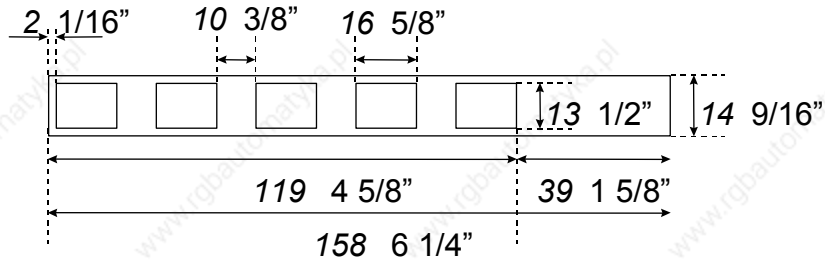

Key:
 mm inches

Figure 17 Model 551/552 Display key label dimensions

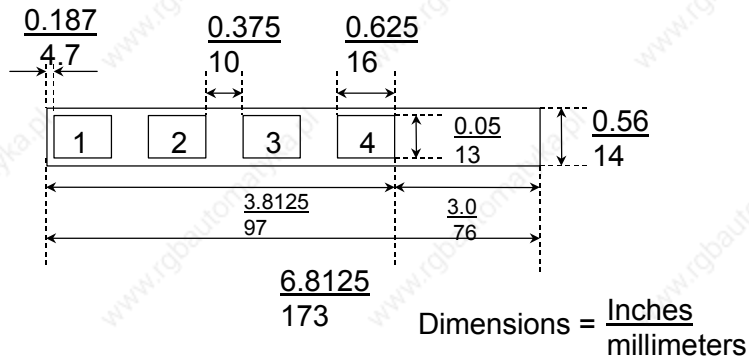

Note: There are 2 labels for 4 keys each

Figure 18 Model 1041 display key label dimensions

Overview of Displays

Display areas defined

Displays have certain areas in common. See Figure 19 and Table 6.

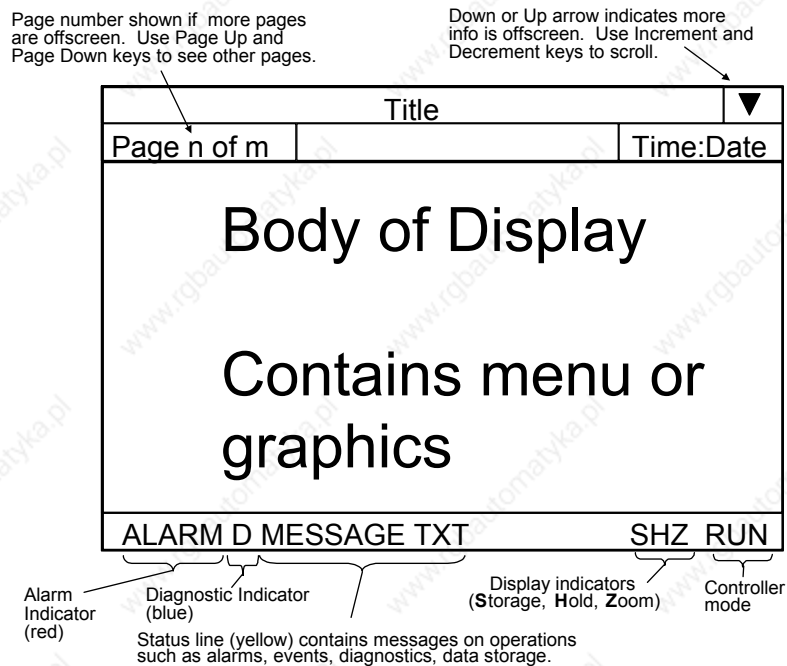

Figure 19 Display areas defined

Table 6 Display areas defined details

Area of Display	Purpose/Description
Title	24-character title describes display contents.
Page Up/Page Down Indicator	Current page number of the active display. Appears when more information is accessible through Page Up and Page Down keys.
Scroll Up/Scroll Down arrow	Indicates there is more information offscreen. Press Increment or Decrement to scroll to more information.
Time:Date	Time and Date
Body of Display	Area between the title and the bottom area contains graphical data or a text menu.
Alarm Indicator	Indicates an alarm exists. When flashing, indicates an alarm is unacknowledged. See <i>Alarms</i> section.
Diagnostics Indicator	Indicates a diagnostic exists. See <i>Controller diagnostics (page 45)</i> .
Status line	Messages about various functions in the controller, including alarms, events, diagnostics, data storage, disk utilities. Note: Only off-to-on events are displayed. See <i>Event summary (page 44)</i> .

Area of Display	Purpose/Description
Controller mode	<p>RUN: Controller is running normally.</p> <p>PROG: Controller is in Program mode.</p> <p>OFLN: Controller is in Offline mode.</p> <p>FAULT: A fault was found reading the Controller switch.</p> <p>NO COMM: This is displayed if controller is not responding.</p>
Display Indicator	<p>Indicates special conditions are in effect for this display.</p> <p>Zoom: A trend display is in zoom (magnification) view mode. See Zoom in Table 83.</p> <p>Hold: A display that usually rotates through several points is on Hold on a single point. See Hold in Table 83.</p> <p>Storage: Data Storage is actively collecting data and saving it to the floppy disk or to the internal buffer. See <i>Data Storage</i> section.</p>

Display organization

Displays are accessed according to the following hierarchy. Notice that the 11 keys in Figure 20 give you direct access to displays. The remaining keys let you navigate within displays and switch to other displays. NOTE: Model 1041 has eight display group keys and a numeric keypad.

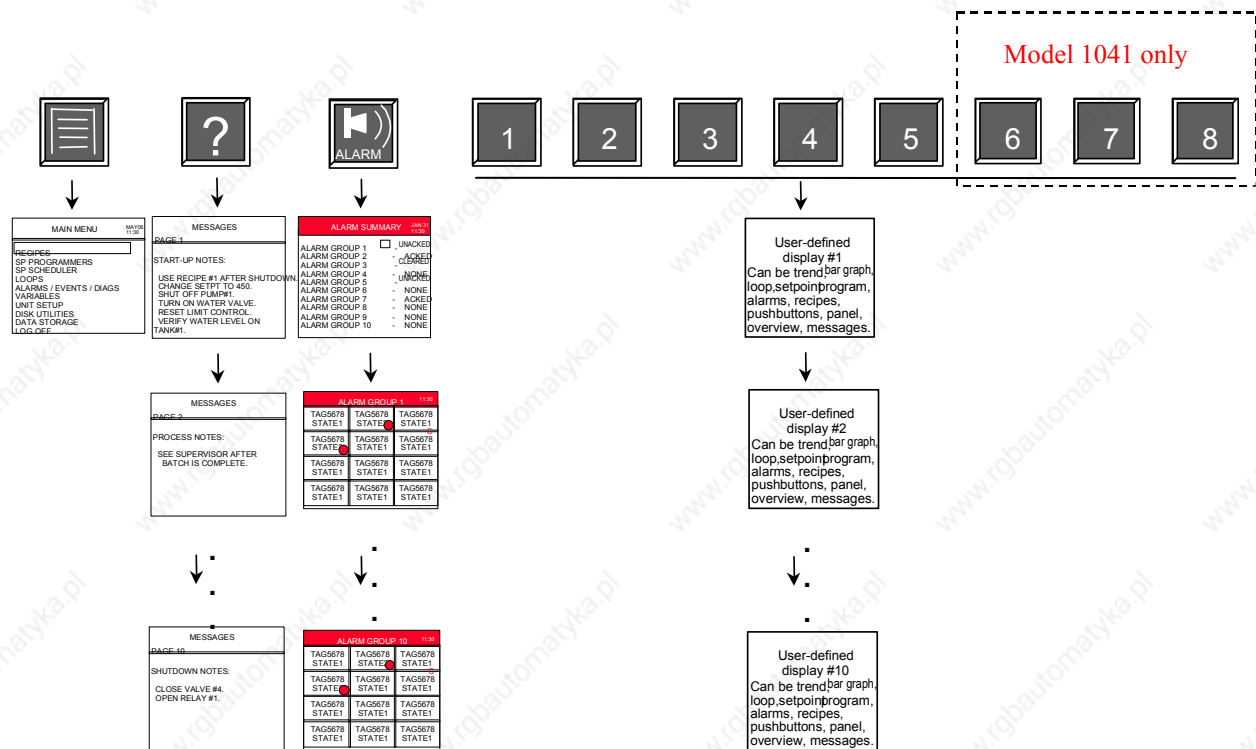



Figure 20 Display organization

Standard displays







The displays accessed under the Menu key are standard; that is, they are not user-assignable. They contain textual descriptions of functions you can choose from. See Main Menu tree in Table 7.

Main menu tree

Access the Main Menu by pressing . The menu is organized as shown in Table 7. Each item is subordinate to the item to its left or upper left.

Note: There are some differences in the main menu structure between the 551/552 and the 1041. In some cases, a single screen on the 1041 can serve to replace multiple related screens on the 551/552 since there is more display space available.

Table 7 Main menu tree

	Recipes	Select Recipe	Edit	Edit Recipe
			Load	
	SP Programmers	Select Program	Edit Program	Save Program
				Edit Segment
	SP Scheduler	Edit Schedule	Edit Segment	Edit Setpoints
				Edit Events
				Edit Guar Hold
				Save Schedule
				Edit Guar Hold Limits
	Loops	Select Loop	Loop Trend	Loop Tune Constants
			Autotune	
			Tune Constants	
			Loop Control Setup	
			Carbon Parameters	
			Alarm Setpoints	
			Limits	
	Alarm/EventDiag	Alarm Summary	Alarm Group	Alarm Detail
			Event Summary	
			Controller Diagnostics	
			I/O Module Diagnostics	
			Panel Diagnostic Log	Delete all Diagnostics (1041)
	Variables	View Variables		

Keys and Displays Overview
Overview of Displays

	Unit Setup		Controller Status		
			Set Mode		
			Set Time and Date		
			Set Security		
			Review Security		
			Set Language		
			Communications	Set Comm A Port	
				Set Comm B Port	
				Slave Device	
			File Name Selections		
			Self Tests	Keyboard Test	
				Display Test	
				Disk Read/Write Test	
			Calibrate AI	Set Controller Mode	Set Mode
				Calibrate Channel	
			Calibrate CJ Temp		
			Copy Calibration		
			Restore AI Factory Cal		
			Restore CJ Factory Cal		
		Calibrate AO	Set Controller Mode		
			Calibrate AO Channel		
			Restore AO Cal		
		Change Display Brightness (1041 only)			

	Disk Utilities			
	List Disk Files			
	Load/Store Profiles	Profiles in Memory	Load Profile from Disk	Load Disk
			Store Profile to Disk	Store Disk
	Load/Store Recipes	Recipes in Memory	Load Recipe from Disk	Load Disk
			Store Recipe to Disk	Store Disk
	Load/Store Schedules	Schedules in Memory	Load Schedule from Disk	Load Disk
			Store Schedule to Disk	Store Disk
	Load Configuration			
	Store Configuration			
	Format Disk			
	Set Controller Mode	Set Mode		

	Data Storage	Storage Status
		Storage Controls
		Initialize Storage Disk
		Load Storage Settings
		View Storage Settings
		Trend 1 Storage
		Trend 2 Storage
		Point Log Storage
	Alarm/Event Storage	
	Start New Storage Settings	
	Store Storage Settings	

	Log Off
---	---------

User-assignable displays

Most of the remaining displays accessed under the remaining keys are selected using the Control Builder. These are described in detail elsewhere in this manual.

Table 8 shows all displays that can be assigned to the display keys. Each item is subordinate to the item to its left or upper left.

Table 8 User-assignable displays

					Model 1041 Only				
1	2	3	4	5	6	7	8		
1	2	3	4	5	16-Loops (Model 1041 only)		Loop Control		
1	2	3	4	5	8-Loops		Loop Control		
1	2	3	4	5	4-Loops		Loop Control		
1	2	3	4	5	3-Loops		Loop Control		
1	2	3	4	5	2-Loops		Loop Control		
1	2	3	4	5	1-Loop Numeric		Loop Control		
1	2	3	4	5	1-Loop w/Loop Trend		Loop Control		
							Loop Tune Constants		
1	2	3	4	5	A/M Bias		Loop Control		
1	2	3	4	5	SP Programmer Operate		Load	Load Program	
							More	Events	
								Detail	
								Edit Program	
								Load Program	
								Save Program	
1	2	3	4	5	SP Scheduler Operate		Load	Load Schedule	
							More	Events	
								Detail	
								Edit Schedule	
								Load Schedule	
								Save Schedule	
1	2	3	4	5	Pushbuttons				
1	2	3	4	5	Selector Switches		Switch Control		
1	2	3	4	5	Device Control		Edit Device		
1	2	3	4	5	Hand/Off/Auto		HOA Switch State		

1	2	3	4	5	Load Recipe	Load
1	2	3	4	5	Trend (Vert)	
1	2	3	4	5	Trend (Horiz)	
1	2	3	4	5	Trend (with Digitals)	
1	2	3	4	5	Trends (with Bar Graphs)	
1	2	3	4	5	Trends (Vert) w/ Horizal Bars	
1	2	3	4	5	Bar Graphs (6 pt Horiz)	
1	2	3	4	5	Bar Graphs (6 pt Vert)	
1	2	3	4	5	Bus Graphs (3 pt Horiz)	
1	2	3	4	5	Bar Graphs (3 pt Vert)	
1	2	3	4	5	Single Pt Panel	
1	2	3	4	5	4-Pt Panel	
1	2	3	4	5	Multi-Pt Panel	
1	2	3	4	5	Panel Meter	
1	2	3	4	5	Overview	
1	2	3	4	5	Alarm Group	
1	2	3	4	5	Data Storage Status	
1	2	3	4	5	Message Text	



TIP

Since the Display Group keys are selectable in the Control Builder, consider taking advantage of this feature by grouping related displays under each Display Group key. For example, on each key you can configure a sequence of 10 displays in order of importance to the process. You can also configure Help text (messages) to appear on these keys.

Main Menu

Overview

The Main Menu contains functions for setting up or adjusting the instrument for operation. For example, you can tune control loops, view events, edit setpoint profiles, calibrate analog inputs or analog outputs, and load and store profiles and recipes.

These functions are organized under the Main Menu, which is accessed by pressing Menu.

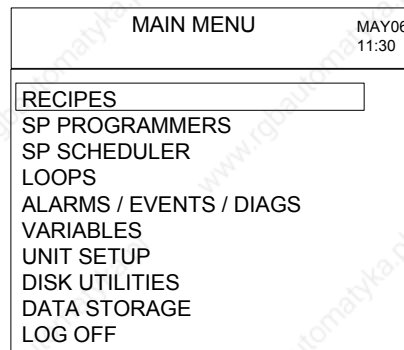

Figure 21 Main menu

Interacting with the menus

Table 4 describes how to use the keys to interact with all the menus.

Table 9 explains the Main Menu functions

Table 9 Main menu functions

Menu Item	Function
Recipes	Lets you view and edit recipes.
SP Programmers	Lets you adjust and set up setpoint programs.
SP Scheduler	Lets you adjust and set up setpoint schedules.
Loops	Lets you adjust and set up control loops.
Alarms/Events/ Diagnostics	Lets you view status of alarms, events, and diagnostics.
Variables	Lets you review variables in the controller's configuration.
Unit Setup	Lets you perform instrument maintenance activities such as calibrating inputs and outputs, setting security, and testing the instrument's functions.
Disk Utilities	Lets you load and store disk files.
Data Storage	Lets you store process data to the floppy disk.
Log Off	Lets you secure the instrument when leaving it unattended.

Recipes

Access

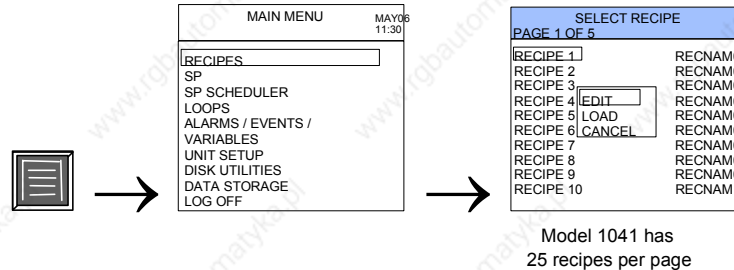

Description

A recipe is a collection of variable signal tags and their values or states. When you load a recipe, the values or states of the signal tags in the recipe replace the values of those signal tags in the controller's configuration.

Procedure

Select a recipe to edit or load. Select Cancel to return to the Main Menu.

Edit recipe

Each recipe can contain up to 50 variables. The setting for an analog point can be any value from -99999 to 99999, and a digital point can be set in its ON or OFF state.

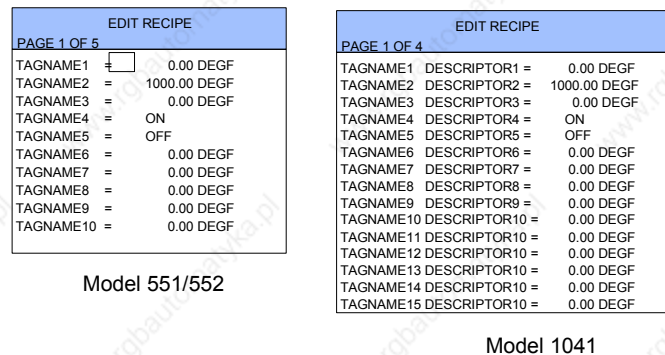

Figure 22 Recipe edit

Table 10 Recipe edit details

Feature	Description
TAGNAME n	The name of the variable in the recipe. A recipe contains up to 50 variables.
Value or State	Indicates the current value or state of the variable. Press Enter to edit.
Page 1 of X	Displays up to 15 variables a page depending on the model
DESCRIPTOR	Optional descriptor of recipe. If descriptor not entered, TAGNAME is repeated.

Load recipe

Select Load to load the recipe into the controller configuration. A message confirms when the load is completed.



TIP

When you load a recipe, you are in effect writing new values to those variables in the configuration. Be aware that the controller configuration may contain a Recipe Load function block that, without your knowledge, can load a second recipe after you loaded one here. If this second recipe is loaded, the values you just loaded may be overwritten by different values. The effect is that some or all of the recipe values or states you intended to load are not in effect.

To check that your recipe load took effect, after loading a recipe you can view the variables to see they are set to the desired recipe values or states. See *Variables* (page 51).

If a recipe's variables do not seem to be loading properly, consider reconfiguring the controller to eliminate the Recipe Load function block that is causing the conflict.

SP Programmers

Access

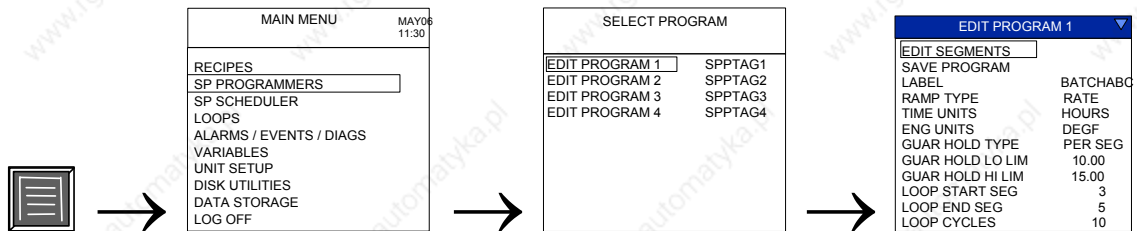

Description

A setpoint programmer supplies a time-varying setpoint to a control loop. A program can contain up to 50 segments. Each segment can be a ramp or a soak. This menu lets you edit setpoint program segments, segment events, or other parameters and save the changes to the controller's memory.

See also

See *Setpoint Programmers* section for details.

SP Scheduler

Access

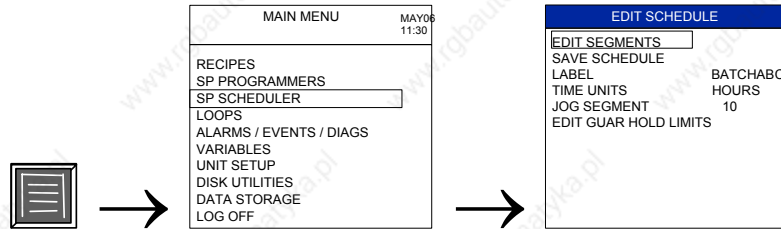

Description

A setpoint scheduler is a function for controlling a multivariable process. A setpoint schedule is a sequence of segments, where each segment contains up to 8 setpoints, up to 8 auxiliary outputs, and up to 16 events.

See also

See *Setpoint Scheduler* section for details.

Loops

Access

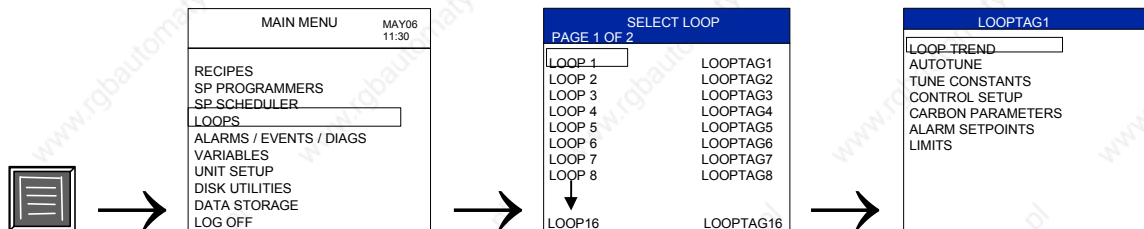

Model 1041 has
16 Loops per page

Description

The Loop menu lets you select a control loop and tune it or adjust its parameters.

See also

See *Loop Setup (page 68)* for details on the Loop menu.

Alarms/Events/Diagnostics

Access

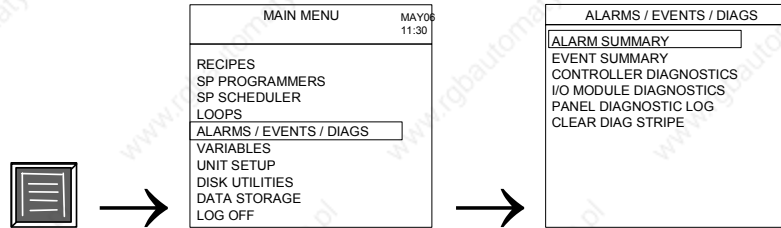

Description

The Alarms/Events/Diagnostics menu lets you view and acknowledge alarms, events, and diagnostics.

Alarm summary

The Alarm Summary presents a status list of up to 10 alarm groups. Each group contains up to 12 points whose alarm status is constantly monitored. See *Alarms* section for more information.

ALARM SUMMARY		JAN 31 11:30
ALARM GROUP 1	<input type="checkbox"/>	UNACKED
ALARM GROUP 2	-	ACKED
ALARM GROUP 3	-	CLEARED
ALARM GROUP 4	-	NONE
ALARM GROUP 5	-	UNACKED
ALARM GROUP 6	-	NONE
ALARM GROUP 7	-	ACKED
ALARM GROUP 8	-	NONE
ALARM GROUP 9	-	NONE
ALARM GROUP 10	-	NONE

Figure 23 Alarm summary

Alarm group

This display lets you see the status of each point in the Alarm Group. See *Alarms* section for details.

ALARM GROUP 1			11:30
TAG5678 STATE1	TAG5678 STATE2	TAG5678 STATE1	C
TAG5678 STATE2	TAG5678 STATE1	TAG5678 STATE1	
TAG5678 STATE1	TAG5678 STATE1	TAG5678 STATE1	
TAG5678 STATE1	TAG5678 STATE1	TAG5678 STATE1	

Figure 24 Alarm group display

Alarm detail

This display shows the time in and time out of a selected alarm in a group, plus two lines of text are available to provide specific detail, information, or help associated with each alarm point. See *Alarm Detail (page 140)* for more information.

ALARM DETAIL		JAN 31 11:30
TAGNAME1 DESCRIPTOR123456		
NO ALARM SINCE LAST RESET		
LAST TIME IN ALARM	JUN 07 98	12:00:00
LAST TIME OUT ALARM	MAY 06 98	08:00:00
FIRST LINE OF HELP TEXT		
SECOND LINE OF HELP TEXT		

Figure 25 Alarm detail display

Event summary

An event is a digital point whose transition warrants operator attention. Event Summary shows the last 10 off-to-on events. On-to-off event transitions are not shown.



ATTENTION

The most recent event is also shown in the event stripe at the bottom of the display. Press Enter to clear the event stripe.

EVENT SUMMARY		JAN 31 20:55
JAN 31 20:51	STAGE 2 IN PROG	
JAN 31 20:50	STAGE 1 COMPLETE	
JAN 31 20:29	STAGE 1 IN PROG	
JAN 31 20:28	PUMP STARTED	
JAN 31 20:25	VALVE 1 OPENED	
JAN 31 20:23	PGM STARTED	
JAN 31 20:16	DOOR CLOSED	
JAN 31 20:15	DOOR OPENED	
JAN 31 20:12	INIT RCP LOADED	
JAN 31 20:10	UNIT STARTED	
CLEAR EVENT STRIPE		

Figure 26 Event summary

Controller diagnostics

This display shows the status of all controller diagnostics.

CONTROLLER DIAGNOSTICS	
SYSTEM	GOOD
CPU	GOOD
MEMORY	GOOD
RTC	GOOD
I/O	GOOD
COMM A	GOOD
COMM B	GOOD

Figure 27 Controller diagnostics

The instrument executes diagnostic routines during instrument start-up and during on-line operation.

Table 11 Details of controller diagnostics

Class	Status	Possible Cause	Controller Action	User Action
SYSTEM	GOOD	Controller is in RUN mode	Executes the run mode. Outputs are updated.	None
SYSTEM	OFFLINE MODE	Controller is in OFFLINE mode	Executes the test mode.	Return to RUN mode as appropriate.
SYSTEM	PROGRAM MODE	Controller is in PROGRAM mode	Function blocks are not executed.	Return to RUN mode as appropriate.
SYSTEM	CONFIG MISMATCH	Attempted to download a config with more than 8 loops into an 8-loop controller	Erases the old configuration from controller memory. Executes an empty configuration.	<ol style="list-style-type: none"> 1. Download a config with 8 or less loops. 2. Upgrade to 16-loop controller.
SYSTEM	SWITCH FAULT	Bad switch	Function blocks are not executed.	<ol style="list-style-type: none"> 1. Toggle controller switch between RUN and PROGRAM. 2. Replace CPU board.
SYSTEM	TASK FAULT	Software failure	Function blocks are not executed.	<ol style="list-style-type: none"> 1. Force a cold start by toggling controller switch between PROGRAM and RUN. 2. Upgrade Controller software. 3. Replace CPU board. 4. Contact Honeywell service.
CPU	GOOD	N/A	N/A	N/A

Class	Status	Possible Cause	Controller Action	User Action
CPU	WATCHDOG	Watchdog reset resulting from software failure	Executes normally.	<ol style="list-style-type: none"> 1. Force a cold start by toggling switch between PROGRAM and RUN. 2. Upgrade Controller software. 3. Replace CPU board. 4. Contact Honeywell Personnel.
CPU	BUS ERROR	Bus Error Detected	Executes normally.	<ol style="list-style-type: none"> 1. Force a cold start by toggling switch between PROGRAM and RUN. 2. Isolate system from noise and force a cold start. 3. Replace CPU board.
CPU	ADDRESS ERROR	Address Error Detected	Executes normally.	<ol style="list-style-type: none"> 1. Force a cold start by toggling switch between PROGRAM and RUN. 2. Isolate system from noise and force a cold start. 3. Replace CPU board.
CPU	INSTRUCTION ERROR	Bad Instruction Detected	Executes normally.	<ol style="list-style-type: none"> 1. Force a cold start by toggling switch between PROGRAM and RUN. 2. Isolate system from noise and force a cold start 3. Replace CPU board.
CPU	VECTOR ERROR	Bad Vector Interrupt	Executes normally.	<ol style="list-style-type: none"> 1. Force a cold start by toggling switch between PROGRAM and RUN. 2. Isolate system from noise and force a cold start. 3. Replace CPU board.
CPU	SPURIOUS INTERRUPT	Spurious Interrupt	Executes normally.	<ol style="list-style-type: none"> 1. Force a cold start by toggling switch between PROGRAM and RUN. 2. Isolate system from noise and force a cold start. 3. Replace CPU board.
MEMORY	GOOD	N/A	N/A	N/A
MEMORY	LOW BATTERY	Battery voltage is low.	Executes normally.	Replace battery.

Class	Status	Possible Cause	Controller Action	User Action
MEMORY	FLASH ERROR	Flash failed to burn	Executes normally.	<ol style="list-style-type: none"> 1. Force a cold start by toggling switch between PROGRAM and RUN. 2. Replace CPU board.
RTC	GOOD	N/A	N/A	N/A
RTC	NOT PROGRAMMED	RTC not programmed	Time and date is set to 00:00:00, January 1, 1970.	Program Real Time Clock.
RTC	BAD DATA	Bad date and time	Time and date is set to 00:00:00, January 1, 1970.	<ol style="list-style-type: none"> 1. Program RTC 2. Disconnect then reconnect power. 3. Replace CPU. 4. Replace boards in backplane. 5. Replace backplane.
RTC	BATTERY FAILURE	RTC battery failed on power-up	Time and date is set to 00:00:00, January 1, 1970.	<p>If LO BAT LED is OFF, cycle power.</p> <p>If LO BAT LED is ON, replace battery and cycle power.</p>
RTC	PROGRAMMING FAILURE	RTC failed to program	Time and date is set to 00:00:00, January 1, 1970.	<ol style="list-style-type: none"> 1. Program RTC. 2. Disconnect then reconnect power. 3. Replace CPU. 4. Replace boards in backplane. 5. Replace backplane.
RTC	READ FAILURE	Unable to read RTC	Time and date is set to 00:00:00, January 1, 1970.	<ol style="list-style-type: none"> 1. Program RTC. 2. Disconnect then reconnect power. 3. Replace CPU. 4. Replace boards in backplane. 5. Replace backplane.
I/O	GOOD	N/A	N/A	N/A
I/O	MODULE ERROR	One of the I/O board diagnostics failed.	N/A	Access the I/O Module diagnostics display.

Class	Status	Possible Cause	Controller Action	User Action
I/O	BAD BACKPAN	Bad backplane EEPROM	Analog inputs use default coefficients.	<ol style="list-style-type: none"> 1. Disconnect then reconnect power. 2. Replace backplane board.
I/O	BAD BACKPAN ID	Incompatible backplane board	Analog inputs use default coefficients.	<ol style="list-style-type: none"> 1. Disconnect then reconnect power. 2. Replace backplane board.
COMM A	GOOD	N/A	N/A	N/A
COMM A	BOARD FAILURE	The Comm Port hardware has a serious failure.	Executes normally.	Replace Comm Port
COMM A	BOARD NOT FOUND	The control file has a non-default address and no Comm Port is installed.	Executes normally.	Install Comm Port or set address to 255
COMM B	GOOD	N/A	N/A	N/A
COMM B	BOARD FAILURE	The Comm Port hardware has a serious failure.	Executes normally.	Replace Comm Port
COMM B	BOARD NOT FOUND	The control file has a non-default address and no Comm Port is installed.	Executes normally.	Install Comm Port or set address to 255

I/O module diagnostics

This display gives the status of each controller module. On Model 551/552, press Page Down to see Modules 9-16.

I/O MODULE DIAGNOSTICS	
PAGE 1 OF 2	
MODULE 1	GOOD
MODULE 2	GOOD
MODULE 3	HI CJ TEMP
MODULE 4	WRONG MODULE
MODULE 5	NO MODULE
MODULE 6	BAD MODULE
MODULE 7	GOOD
MODULE 8	GOOD
↓	
MODULE 16	GOOD

Model 1041 has
16 modules per page

Figure 28 I/O module diagnostics

Table 12 I/O module diagnostics details

Class	Status	Possible Cause	Controller Action	User Action
MODULE 1 through MODULE 16	GOOD	Module matches the configuration OR the module is not present nor needed in the control configuration.	N/A	N/A
MODULE 1 through MODULE 16	HI CJ TEMP	Cold junction temperature is high on AI module.	Executes normally.	<ol style="list-style-type: none"> 1. Improve ventilation to rack. 2. Replace AI module.
MODULE 1 through MODULE 16	WRONG MODULE	The module does not agree with the module required for the control configuration.	These block types do the following: AI - sets its output to failsafe DI - sets its output to OFF	Replace module or check configuration.

Class	Status	Possible Cause	Controller Action	User Action
MODULE 1 through MODULE 16	NO MODULE	No module found in the slot that requires a module for the control configuration.	These block types do the following: AI - sets its output to failsafe DI - sets its output to OFF	Install the module.
MODULE 1 through MODULE 16	BAD MODULE	Analog input or analog output board does not have factory coefficients, or the I/O board is not a supported type.	If the error is an analog input board with no factory coefficients, default coefficients will be used for the cold-junction calculations. If the error is an analog output board with no factory coefficients, default coefficients will be used for the outputs. If the board is an unsupported type, these block types do the following: AI - sets its output to failsafe DI - sets its output to OFF	Replace module.

Panel diagnostic log

The Panel Diagnostic Log is a time-ordered list of the diagnostic messages that appear on the status line (at the bottom of the display). This log will hold up to 5 items. The log is cleared when the user selects the DELETE ALL DIAGNOSTICS item from the menu and press ENTER.

PANEL DIAGNOSTIC LOG		JAN 31 20:55
12:34:56	JAN31 99	DIAGNOSTIC TEXT
2:34:56	JAN30 99	DIAGNOSTIC TEXT
3:34:56	JAN29 99	DIAGNOSTIC TEXT
1:23:45	JAN28 99	DIAGNOSTIC TEXT
4:34:56	JAN27 99	DIAGNOSTIC TEXT
DELETE ALL DIAGNOSTICS		

Figure 29 Panel diagnostic log

Clear diagnostic stripe (Model 551/552 only)

In the event a diagnostic has occurred, this menu item lets you erase the diagnostic stripe at the bottom of the screen. It also erases the items from the Panel Diagnostic Log.

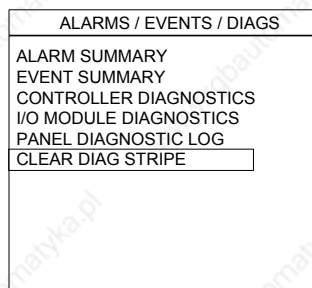
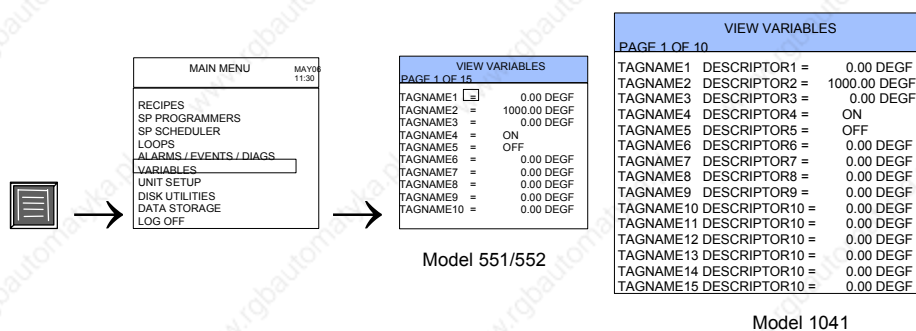

Figure 30 Clear diagnostic stripe

Variables

Access



Description

A variable is a digital or analog tagged element of a control configuration which allows operator input to connected function blocks. The View Variable display lets you view values or discrete statuses of variables that affect your process.

Table 13 View variable details

Feature	Description
TAG NAME n	Name of variable.
Value or state	The setting for an analog point can be any appropriate value from -99999 to 99999, and a digital point can be set in its ON or OFF state.
DESCRIPTOR (1041)	Optional descriptor of variable. If descriptor is not used, TAGNAME is repeated

See also

To edit a variable, use the Overview screen. See *Overview (page 158)*.

Unit Setup

Access

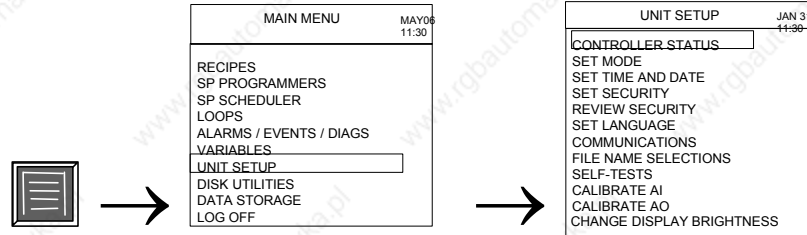

Description

Unit Setup gives you access to maintenance functions of the unit, such as calibration, setting the clock, setting security access, and self-tests. See *Unit Setup* (page 179).

Disk Utilities

Access

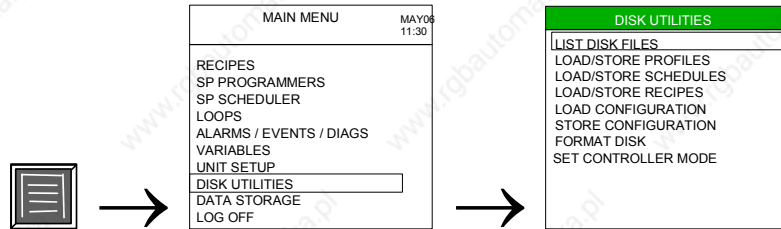

Description

Disk Utilities lets you load files from the diskette to the controller, or store files from the controller to the diskette.

Diskette insertion

Step	Action
1	Open door and insert the diskette. While the door is open "BEZEL OPEN" is displayed.
2	Close door. "CHECKING DISK" is displayed while the diskette is checked for proper formatting and ready for use. When the message goes away, the diskette is ready for use.

Load

Load means to copy a file from the diskette to the controller.

Store

Store means to copy a file from the controller to the diskette.

See also

While performing Disk Utilities, messages may be displayed. See Table 119 for message descriptions.

List disk files

This display lists all files on the diskette, including all non-UMC800 files.

LIST DISK FILES	
UNIT01	FBD
UNIT02	FBD
BATCH01	PRF
BATCH01	RCP
FILE01	SCH
FILE02	DSS

Figure 31 List disk files

Table 14 List disk files details

Feature	Description										
FILENAME.EXT	<p>UMC800 File types are identified by the following extensions.</p> <table> <tr> <td>.FBD</td> <td>Configuration</td> </tr> <tr> <td>.PRF</td> <td>SP Profile</td> </tr> <tr> <td>.SCH</td> <td>SP Schedule</td> </tr> <tr> <td>.RCP</td> <td>Recipe</td> </tr> <tr> <td>.DSS</td> <td>Data Storage Set</td> </tr> </table>	.FBD	Configuration	.PRF	SP Profile	.SCH	SP Schedule	.RCP	Recipe	.DSS	Data Storage Set
.FBD	Configuration										
.PRF	SP Profile										
.SCH	SP Schedule										
.RCP	Recipe										
.DSS	Data Storage Set										

Anatomy of UMC800 filenames

This applies only to files created on the Operator Interface.

XXXXXX01.FBD

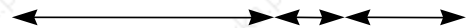

<u>prefix</u>	<u>suffix</u>	<u>extension</u>
6 characters	1-70	Automatically assigned according to file type



TIP

1. Use Increment and Decrement to see more files.
2. If no files are on the diskette, "NO FILES" is displayed.
3. All files on the diskette are shown, not just UMC800 files.

Load/store SP profiles

This function lets you

- load profiles from the diskette to the Controller's RAM memory, or
- store profiles from the Controller's RAM memory to the diskette.

PROFILES IN MEMORY	
PAGE 1 OF 7	
PROFILE 1	LABEL678
PROFILE 2	LABEL678
PROFILE 3	LABEL678
PROF LOAD PROFILE FROM DISK	78
PROF STORE PROFILE TO DISK	78
PROFILE 6	LABEL678
PROFILE 7	LABEL678
PROFILE 8	LABEL678
PROFILE 9	LABEL678
PROFILE 10	LABEL678
▼	
PROFILE 25	LABEL678

Model 1041 has
25 Profiles per page

Figure 32 Load/store profiles

Description

Once a profile is loaded into the Controller's memory with Load Profile from Disk, it can be loaded from memory into a Setpoint Program where it can be run. Therefore, to run a profile that is on the diskette, you must first Load Profile From Disk to memory, then load the profile from memory to the Setpoint Programmer. To do the latter, see Load program(*page 106*).

Conversely, to store to disk a program being run by the Setpoint Programmer, you must save the program from the Setpoint Program to memory, then Store Profile To Disk. To do the former, see Save program(*page 99*).

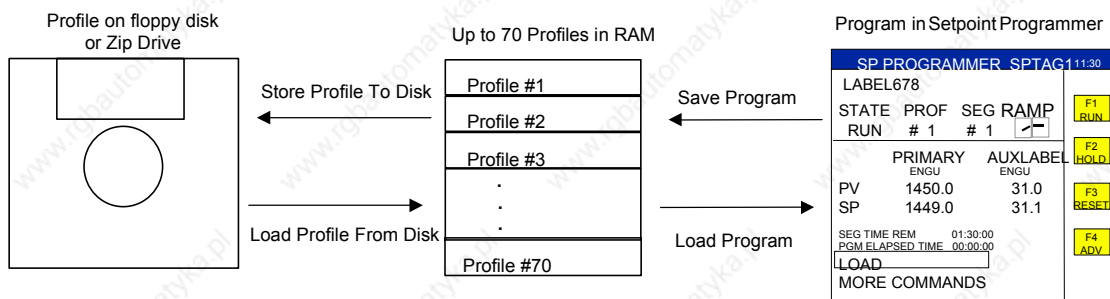

Figure 33 Relationship between diskette, profile memory, and setpoint programmer

Select one of up to 70 profiles from the Load/Store Profiles display. This is the profile memory location you will load to or store from.

Next, you will either:

- load a profile from the diskette to the selected profile location in Controller memory, or
- store the profile from this profile location to the diskette.

Table 15 Load/store profiles details

Feature	Description
LOAD PROFILE FROM DISK	<p>Select this to load the selected disk profile to the selected "slot" in Controller memory. Once in memory, the profile can be loaded into a setpoint programmer where it can be run.</p> <p>After selecting LOAD PROFILE FROM DISK, the following display appears.</p> <div data-bbox="724 726 1062 1037" style="border: 1px solid black; padding: 5px; margin: 10px auto; width: fit-content;"> <p style="text-align: center;">LOAD PROFILE 1 FROM DISK</p> <hr/> <p>BATCH 01 PRF BATCH 02 PRF PROFIL01 PRF PROFIL02 PRF PROFIL03 PRF</p> </div> <p>Select the desired profile to load from disk and press Enter to load it to the selected Controller memory profile location. The message NO FILES means no profiles are on the disk.</p>
STORE PROFILE TO DISK	<p>Select this to store the selected profile from Controller memory (1-70) to the diskette.</p> <p>After selecting STORE PROFILE TO DISK, the following display appears.</p> <div data-bbox="729 1266 1055 1562" style="border: 1px solid black; padding: 5px; margin: 10px auto; width: fit-content;"> <p style="text-align: center;">STORE PROFILE 1 TO DISK</p> <hr/> <p>FILE <input style="width: 50px;" type="text"/> PROFIL01 PRF FILES ON DISK: BATCH 01 PRF BATCH 02 PRF PROFIL01 PRF PROFIL02 PRF PROFIL03 PRF</p> </div> <p>At the FILE prompt, select a filename and number for the profile being stored. Use Increment/Decrement to see available file names and numbers. Press Enter to store.</p>

See also

See Load program (page 106), Save program (page 99).

While performing Disk Utilities, messages may appear. See Table 119 for message descriptions.

Load/store SP schedules

This function lets you

- load schedules from the diskette to the Controller's RAM memory, or
- store schedules from the Controller's RAM memory to the diskette.

SCHEDULES IN MEMORY	
SCHEDULE 1	LABEL678
SCHEDULE 2	LABEL678
SCHEDULE 3	LABEL678
SCH	LOAD SCHEDULE FROM DISK
SCH	STORE SCHEDULE TO DISK
SCHEDULE 6	LABEL678
SCHEDULE 7	LABEL678
SCHEDULE 8	LABEL678
SCHEDULE 9	LABEL678
SCHEDULE 10	LABEL678

Figure 34 Load/store schedules

Description

Once a profile is loaded into the Controller's memory with Load Schedule from Disk, it can be loaded from memory into the Setpoint Scheduler where it can be run. Therefore, to run a schedule that is on the diskette, you must first Load Schedule From Disk to memory, then load the schedule from memory to the Setpoint Scheduler. To do the latter, see Load in Table 70.

Conversely, to store to disk a schedule being run by the Setpoint Scheduler, you must save the schedule from the Setpoint Schedule to memory, then Store Schedule To Disk. To do the former, see Save schedule *Page 120*.

Table 16 Load/store schedules details

Feature	Description
<p>LOAD SCHEDULE FROM DISK</p>	<p>Select this to load the selected schedule to one of 10 “slots” in Controller memory. Once in memory, the schedule can be loaded into a configuration.</p> <p>After selecting LOAD SCHEDULE FROM DISK, the following display appears.</p> <div data-bbox="789 499 1081 768" style="border: 1px solid black; padding: 5px; margin: 10px auto; width: fit-content;"> <p style="background-color: #008000; color: white; text-align: center; padding: 2px;">LOAD SCHEDULE 1 FROM DISK</p> <p>BATCH 01 SCH <input style="width: 100px;" type="text"/></p> <p>BATCH 02 SCH</p> <p>PROFIL01 SCH</p> <p>PROFIL02 SCH</p> <p>PROFIL03 SCH</p> </div> <p>Select the desired schedule to load from disk and press "Enter" to load it to Controller memory. The status of the load is shown on the display. The message NO FILES means no schedules are on the diskette.</p>
<p>STORE SCHEDULE TO DISK</p>	<p>Select this to store the selected schedule from Controller RAM memory to the diskette.</p> <p>After selecting STORE SCHEDULE TO DISK, the following display appears.</p> <div data-bbox="766 1024 1101 1331" style="border: 1px solid black; padding: 5px; margin: 10px auto; width: fit-content;"> <p style="background-color: #008000; color: white; text-align: center; padding: 2px;">STORE SCHEDULE 1 TO DISK</p> <p>FILE <input style="width: 100px;" type="text"/> UNIT <input style="width: 50px;" type="text"/> 01 SCH</p> <p>FILES ON DISK:</p> <p>BATCH 01 SCH</p> <p>BATCH 02 SCH</p> <p>PROFIL01 SCH</p> <p>PROFIL02 SCH</p> <p>PROFIL03 SCH</p> </div> <p>At the FILE prompt, select a filename and number for the schedule being stored. Use increment/decrement to see available file names and numbers. Press "Enter" to store. The status of the store is shown on the display.</p>

Load/store recipes

This function lets you

- load recipes from the diskette to the Controller's RAM memory, or
- store recipes from the Controller's RAM memory to the diskette.

RECIPES IN MEMORY	
PAGE 1 OF 5	
RECIPE 1	LABEL678
RECIPE 2	LABEL678
RECIPE 3	LABEL678
RECIPE 4	LOAD RECIPE FROM DISK
RECIPE 5	STORE RECIPE TO DISK
RECIPE 6	LABEL678
RECIPE 7	LABEL678
RECIPE 8	LABEL678
RECIPE 9	LABEL678
RECIPE 10	LABEL678
↓	
RECIPE 25	LABEL678

Model 1041 has
25 recipes per page

Figure 35 Load/store recipes

Description

A recipe is a collection of variable signal tags and their values or states. When you load a recipe into controller memory, the recipe becomes available to be loaded into the configuration. By subsequently loading a recipe from controller memory into a configuration, the values or states of the signal tags in the recipe replace the values of those signal tags in the controller's configuration.

Select one of up to 50 recipes from the Recipes In Memory display. As explained next in Table 17, you will either

- load a recipe from the diskette to the selected recipe location in Controller memory, or
- store the recipe from this recipe location to the diskette.



TIP

Do not confuse LOAD RECIPE FROM DISK (into memory) with LOAD RECIPE (into the controller's configuration). See *Load recipe* (page 41).

Table 17 Load/store recipes details

Feature	Description												
<p>LOAD RECIPE FROM DISK</p>	<p>Select this to load the selected recipe to one of 50 “slots” in Controller memory. Once in memory, the recipe can be loaded into a configuration.</p> <p>After selecting LOAD RECIPE FROM DISK, the following display appears.</p> <div data-bbox="764 491 1105 802" style="border: 1px solid black; padding: 5px; margin: 10px auto; width: fit-content;"> <p style="background-color: #008000; color: white; text-align: center; padding: 2px;">LOAD RECIPE 1 FROM DISK</p> <table border="1" style="width: 100%; border-collapse: collapse;"> <tr> <td style="padding: 2px;">PRDUCT01 RCP</td> </tr> <tr> <td style="padding: 2px;">PRDUCT02 RCP</td> </tr> <tr> <td style="padding: 2px;">PRDUCT03 RCP</td> </tr> <tr> <td style="padding: 2px;">PRDUCT04 RCP</td> </tr> <tr> <td style="padding: 2px;">PRDUCT05 RCP</td> </tr> </table> </div> <p>Select the desired recipe to load from disk and press Enter to load it to Controller memory. The status of the load is shown on the display. The message NO FILES means no recipes are on the disk.</p>	PRDUCT01 RCP	PRDUCT02 RCP	PRDUCT03 RCP	PRDUCT04 RCP	PRDUCT05 RCP							
PRDUCT01 RCP													
PRDUCT02 RCP													
PRDUCT03 RCP													
PRDUCT04 RCP													
PRDUCT05 RCP													
<p>STORE RECIPE TO DISK</p>	<p>Select this to store the selected recipe from Controller RAM memory to the diskette.</p> <p>After selecting STORE RECIPE TO DISK, the following display appears.</p> <div data-bbox="773 1058 1092 1346" style="border: 1px solid black; padding: 5px; margin: 10px auto; width: fit-content;"> <p style="background-color: #008000; color: white; text-align: center; padding: 2px;">STORE RECIPE 1 TO DISK</p> <table border="1" style="width: 100%; border-collapse: collapse;"> <tr> <td style="padding: 2px;">FILE</td> <td style="padding: 2px;">PRDUCT01RCP</td> </tr> <tr> <td style="padding: 2px;">FILES ON DISK:</td> <td style="padding: 2px;">PRDUCT01 RCP</td> </tr> <tr> <td></td> <td style="padding: 2px;">PRDUCT02 RCP</td> </tr> <tr> <td></td> <td style="padding: 2px;">PRDUCT03 RCP</td> </tr> <tr> <td></td> <td style="padding: 2px;">PRDUCT04 RCP</td> </tr> <tr> <td></td> <td style="padding: 2px;">PRDUCT05 RCP</td> </tr> </table> </div> <p>At the FILE prompt, select a filename and number for the recipe being stored. Use Increment/Decrement to see available file names and numbers. Press "Enter" to store. The status of the store is shown on the display.</p>	FILE	PRDUCT01RCP	FILES ON DISK:	PRDUCT01 RCP		PRDUCT02 RCP		PRDUCT03 RCP		PRDUCT04 RCP		PRDUCT05 RCP
FILE	PRDUCT01RCP												
FILES ON DISK:	PRDUCT01 RCP												
	PRDUCT02 RCP												
	PRDUCT03 RCP												
	PRDUCT04 RCP												
	PRDUCT05 RCP												

See also

While performing Disk Utilities, messages may be displayed. See Table 119 for message descriptions.

Load configuration

Lets you load a configuration from the diskette to the Controller. When you select “Load Configuration” from the disk utilities menu, a Warning will appear. Controller must be in PROGRAM mode.

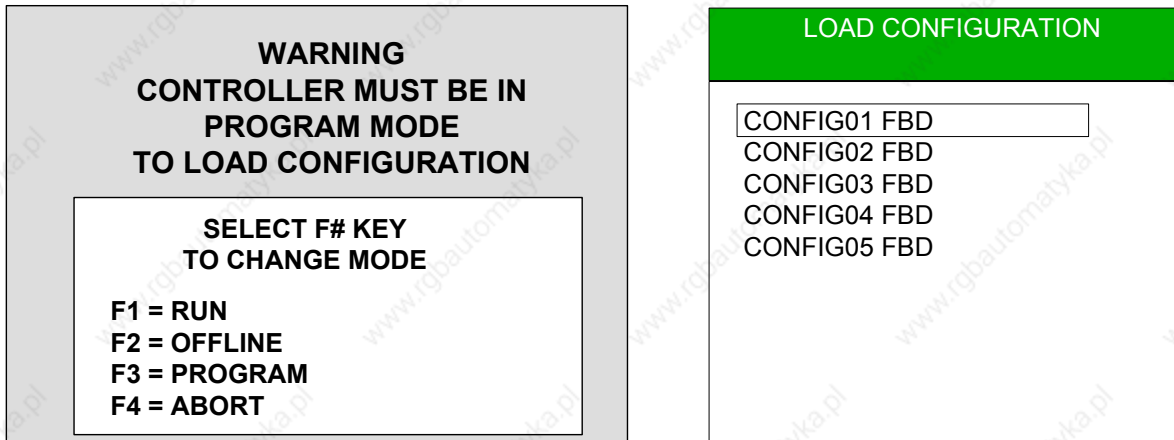

Figure 36 Load configuration

Table 18 Load configuration details

Feature	Description
FILES ON DISK	Select a configuration (.FBD extension) to be loaded into the Controller. Press Enter to proceed. A warning message will be displayed. This utility will overwrite the existing controller configuration. Press Escape to abort the load, or press Enter to load it into the Controller. The existing Controller configuration will be overwritten by the new one. The status of the load is shown on the display.



TIP

Controller must be in Program mode.

Use Increment and Decrement keys to see more files on the disk.

NO FILES message means no configuration files; there may be other file types on the diskette.

See also

While performing Disk Utilities, messages may be displayed. See Table 119 for message descriptions.

Store configuration

Lets you store the controller's configuration to the diskette.

STORE CONFIGURATION	
FILE	<input type="text" value="CONFIG01"/> FBD
FILES ON DISK:	PRDUCT01 FBD PRDUCT02 FBD PRDUCT03 FBD PRDUCT04 FBD PRDUCT05 FBD

Figure 37 Store configuration

Table 19 Store configuration details

Feature	Description
FILE	Select a name and number for the configuration. Press Enter to store it to disk. The status of the store is shown on the display.
FILES ON DISK	Lists the existing files on the disk. Configurations have .FBD extension. Use Increment and Decrement keys to see more files on the disk.

See also

While performing Disk Utilities, messages may be displayed. See Table 119 for message descriptions.

Format disk

This DOS-formats a floppy disk for storage of recipes, profiles, or configurations.

Formatting a Zip drive is unavailable here and must be done on a PC.

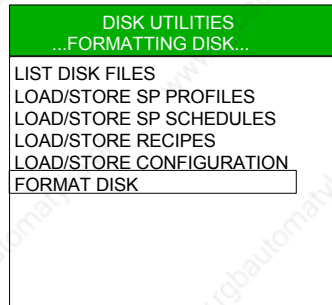

Figure 38 Format disk

Table 20 Format disk details

Feature	Description
FORMAT DISK	<p>Select this to format the floppy disk. A warning message will be displayed. Escape to abort the format or press Enter to begin.</p> <p>All disk data will be erased. The message FORMATTING DISK will appear until formatting is complete, then FORMAT COMPLETE is displayed. Press any key to cancel formatting.</p>

See also

While performing Disk Utilities, messages may be displayed. See Table 119 for message descriptions.

Set Controller Mode

This lets you change the Controller's operating mode. It has the same effect as if you changed the mode switch on the controller.

The current mode is indicated on the bottom right of the display.

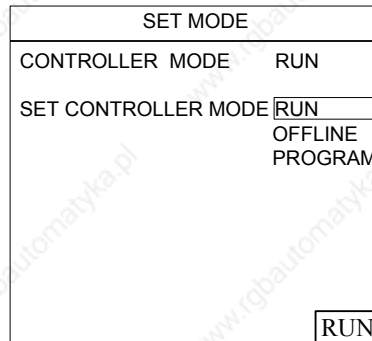

Figure 39 Set mode

Table 21 Set mode details

Feature	Description
CONTROLLER MODE	Current mode of the controller. See Table 22
SET CONTROLLER MODE	<p>RUN: Select this to resume running the process.</p> <p>OFFLINE: Select this before performing these tasks:</p> <ul style="list-style-type: none"> • Calibration • Downloading a .DSS (data storage) file. <p>PROGRAM: Select this before performing these tasks:</p> <ul style="list-style-type: none"> • Calibration • Downloading a .FBD (configuration) file.

Table 22 Controller modes defined

Mode	Function Blocks Executed?	Outputs Updated?	Effect upon return to RUN mode?
RUN	Yes	Yes	None
OFFLINE	No	No	Resumes running
PROGRAM	No	No	Cold start



TIP

- If the controller switch is set to RUN but the mode was set to PROGRAM or OFFLINE here, following a power cycle the mode will return to RUN.
- Changing from Program to Run causes data in RAM (setpoint profiles, recipes) to be copied to non-volatile (FLASH) memory.
- In a cold start, all data storage and display buffers are cleared and accumulated values of some function blocks (such as totalizers) are reset.
- In a warm start, all buffered data and values are retained and the process resumes where it left off.

Data Storage

Access

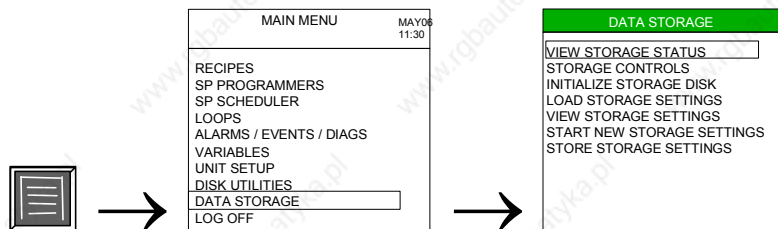

Description

Data Storage lets you store information on a diskette. Trends, a point log, alarms, and events are collected in separate files on a diskette for later analysis and review on a PC with SDA data analysis software.

See also

See *Data Storage* section for details.

Log Off/Log On

Access

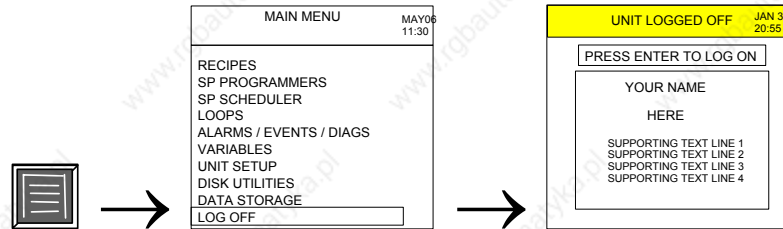

Description

Access the Log Off display to

- deter unwanted users from interacting with the instrument. If Log Off security is enabled the operator must enter a security code to log on. See *Set Security/Review Security (page 183)*.
- learn the part number and firmware revision number of the operator interface.

Table 23 Log off display details

Feature	Description
PRESS ENTER TO LOG ON	Press Enter to return to the process. If security is not enabled, you are returned to the Display Group 1 key's first display. If security is enabled, you are prompted to enter the security code before gaining access to the display.
PART #	Operator Interface part number.
REV. #	Operator Interface firmware revision number.
SUPPORTING TEXT	Custom text

Loops

Overview

The two main tasks associated with loops are setup and operation. Setup is done through the Loop menu and is described in *Loop Setup*. Operation is done through various loop displays accessed through the display keys **1** through **5** (through 8 for Model 1041) and is described in *Loop Operation*.

Loop modes

All loop displays indicate the current operating mode of the selected loop. Loop modes are described in Table 24.

Table 24 Loop modes

Loop mode	Meaning
AUTO RSP	Loop is controlling the process and Remote Setpoint is selected.
MAN RSP	Loop output can only be changed manually. Remote Setpoint is selected.
IMAN RSP	IMAN (Initialization Manual) occurs with Cascade loops only. Figure 40. Secondary Cascade is in MAN or LSP, therefore Primary Cascade output is tracking Secondary Cascade's PV. Remote Setpoint is selected.
LO RSP	LO (Local Override): loop output is tracking the loop's Output Tracking value. Remote Setpoint is selected.
AUTO LSP	Loop is controlling the process and Local Setpoint is selected.
MAN LSP	Loop output can only be changed manually. Local Setpoint is selected.
IMAN LSP	IMAN (Initialization Manual) occurs with Cascade loops only. Figure 40. Secondary Cascade is in MAN or LSP, therefore Primary Cascade output is tracking Secondary Cascade's PV. Local Setpoint is selected.
LO LSP	LO (Local Override): loop output is tracking the loop's Output Tracking value. Local Setpoint is selected.

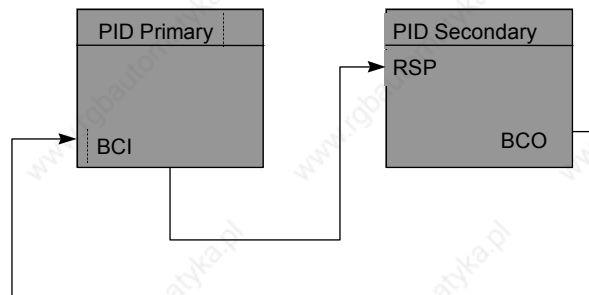

When PID Secondary is in Manual or when Local Setpoint is selected, PID Primary mode is IMAN. IMAN causes the PID Primary output to track the PID Secondary PV.

Figure 40 IMAN loop mode

Loop Setup

Loop setup is done through the Loops menu, accessed through the Main Menu.

Access

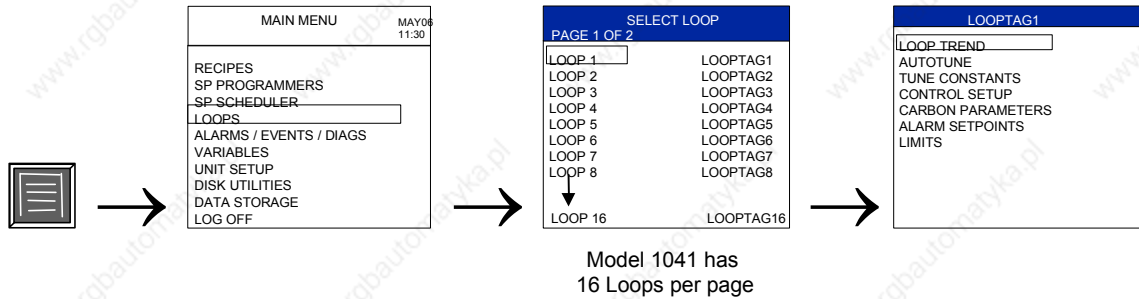

Select loop

Select a loop. The loop menu for that loop will appear.

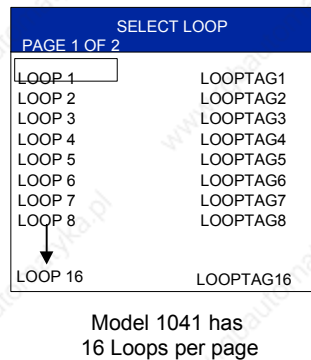

Figure 41 Select loop

Model 551/552 - Use Page Up and Page Down keys to see the next or previous page of loops.

See also

While performing Loop menu functions, messages may be displayed. See Table 119 for message descriptions.

Loop menu

After selecting a loop to set up, the Loop menu for that loop appears.

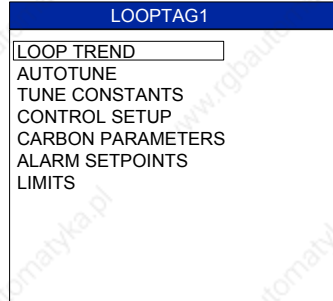

Figure 42 Loop menu display

Items on the Loop menu are visible according to the loop type.

Table 25 Loop menu visibility

Menu item	Loop type				
	PID	ON/OFF	3 POS	CARBON	A/M BIAS
LOOP TREND	X		X	X	
AUTOTUNE	X		X	X	
TUNE CONSTANTS	X		X	X	
CONTROL SETUP	X	X	X	X	X
CARBON PARAMETERS				X	
ALARM SETPOINTS	X	X	X	X	X
LIMITS	X	X	X	X	X
X indicates item is visible					

Select one of the following functions from the Loop Menu.

Loop Function	See page
Loop Trend	70
Autotune	71
Tune Constants	72
Control Setup	73
Carbon Parameters	75
Alarm Setpoints	76
Limits	78

Loop trend

The Loop Trend shows a graphical and textual overview of a selected loop.

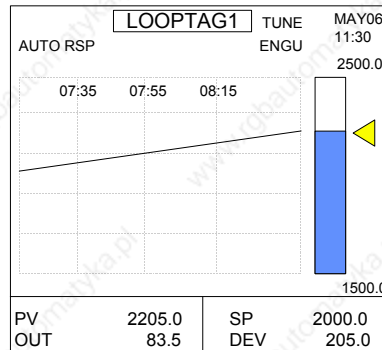



Figure 43 Single loop trend

Table 26 Details of single loop trend

Feature	Description
Loop mode	See Table 24 for details. To change between AUTO and MAN modes, press Auto/Manual.
Loop Tag	Press Detail to move cursor to this, then press Enter to display the Loop Tune Constants display. See <i>Loop tune constants</i> (page 72). You can switch between these two displays; the trend line will be buffered.
	Setpoint value of the loop.
PV bar graph on right side	Current value of PV
PV value at lower left	Current value of PV
PV trend	Shows PV over the last timebase. Timebase can be changed by switching to Loop Tune Constants display. See <i>Loop tune constants</i> (page 72).
OUT	Loop output. To change, press Detail to move cursor. Press Increment and Decrement to change value. Loop must be in MAN.
SP	Setpoint value. To change, press Detail to move cursor. Press Increment and Decrement to change value.
DEV	PV's deviation from setpoint.
TUNE	When this is visible, Loop is being tuned automatically. See <i>Loop Autotune</i> (page 71).

Bold items are read-only.



TIP

This display is not selectable from the Loop Menu for ON/OFF or A/M BIAS loop type.

Loop Autotune

This display lets you set up and start the loop tuning function. When initiated, the controller will start controlling to the setpoint while it identifies the process, calculates the tuning constants, and begins PID control with the correct tuning parameters.

LOOP TUNING	
LOOPTAG1	AUTO LSP ENGU
STATUS	INACTIVE
PV	1234567
OUTPUT	1234567
SETPOINT	1234567
FUZZY	OFF
ACCUTUNE	ENABLE
TUNE SET	TSET 1
START TUNE	

Figure 44 Loop auto tune display

Table 27 Details of loop auto tune

Feature	Description
Loop mode	See Table 24 for details. To change between AUTO and MAN modes, press Auto/Manual.
STATUS	Inactive, Tuning (is in progress)
PV	Value of Process Variable
OUTPUT	Output of loop
SETPOINT	Value of setpoint
FUZZY	Select ON to activate Fuzzy Overshoot Suppression to minimize overshoot after a setpoint change or a process disturbance. Select OFF to disable Fuzzy Logic. The fuzzy logic observes the speed and direction of the PV signal as it approaches the setpoint and temporarily modifies the internal controller response action as necessary to avoid an overshoot. There is no change to the PID algorithm, and the fuzzy logic does not alter the PID tuning parameters. This feature can be independently Enabled or Disabled as required by the application to work with "TUNE" On-Demand tuning.
ACCUTUNE	Select Enable to display the tuning menu items below. Select Disable to hide them from view.
TUNE SET	TSET1 uses Gain #1, Rate #1, Reset #1. TSET2 uses Gain #2, Rate #2, Reset #2.
START TUNE	Select this to begin the autotuning process.

Bold items are read only.



TIP

This display is not selectable from the Loop Menu for ON/OFF or A/M BIAS loop type.

Loop tune constants

This display shows the tuning constants for the selected loop.

LOOP TUNE CONSTANTS	
LOOPTAG1	AUTO LSP ENGU
GAIN#1	1234567
RESET#1 MINS	1234567
RATE#1	1234567
GAIN#2	1234567
RESET#2 MINS	1234567
RATE#2	1234567
FEEDFORWARD GAIN	1234567
MANUAL RESET	1234567
TUNE SET	TSET 1
SET TIMEBASE	30 MIN

Figure 45 Loop tune constants

Table 28 Details of loop tune constants

Feature	Description
GAIN #1 OR #2 *	Gain is the ratio of the output change (%) over the measured variable change (%) that caused it. Gain = 100/Proportional Band
PROPORTIONAL BAND (PB) # 1 OR #2 *	PB is the percent of the range of the measured variable for which a proportional controller will produce a 100% change in its output.
RATE #1 OR #2	Rate affects the controller's output whenever the deviation is changing; and affects it more when the deviation is changing faster.
RESET #1 OR #2	Reset, or integral time, adjusts the controller's output according to the size of the deviation (SP - PV) and the time it lasts. The amount of corrective action depends on the value of Gain. Reset is measured as how many times proportional action is repeated per minute (repeats/minute) or how many minutes before one repeat of the proportional action occurs (minutes/repeat).
FEEDFORWARD GAIN**	Applies Gain to the feedforward variable (FFV).
MANUAL RESET**	Manual Reset is only applicable if you do not use Reset. It allows correction of output to account for load changes to bring the PV up to setpoint.
TUNE SET	Select #1 or #2. Determines which set of Gain/PB, Rate, and Reset is used by the loop.
SET TIMEBASE	Determines the time axis of the loop trend display: 5 minutes (model 551/552 only), 15, 30 minutes, 1, 2, 4, 24, or 8 hours. Default for Model 1041 is 30 minutes. See <i>Loop trend (page 70)</i> for details.

*Either Gain or PB is visible but not both. Visibility is selectable with the Control Builder.

**Visible only if Loop Type is PID, 3POS Step, or CARBON.



TIP

- You can also access this screen from the Loop Trend (page 70). Pressing Escape will return you to the Loop Trend, preserving the buffered trend data.
- If you access this screen from the Loop menu, the Loop Trend's buffered data is not preserved.

Loop control setup

The Loop Control Setup Display shows parameters of the selected loop.

LOOP CONTROL SETUP	
LOOPTAG1	AUTO LSP ENGU
TYPE	PID
PV	1234567
OUTPUT	1234567
LOCAL SP	1234567
REMOTE SP	1234567
SWITCH SP	
FAILSAFE OUT	1234567
GAIN	1234567
BIAS	1234567
MOTOR DEADBAND %	1234567
MOTOR TRAVERSE TIME (SEC)	1234567
HYSTERESIS	1234567

Figure 46 Loop control setup

Table 29 Details of loop control setup

Feature	Description
Loop mode	See Table 24 for details. To change between AUTO and MAN modes, press Auto/Manual.
TYPE	PID, ON/OFF, CARBON, 3 POS, A/M BIAS
PV	Value of process variable.
OUTPUT	Loop's output in %.
LOCAL SP*	Value of Local Setpoint.
REMOTE SP*	Value of Remote Setpoint. This value is changeable only if it is configured as a second Local Setpoint (LSP2). It is read-only if it is connected to a function block within the configuration.
SWITCH SP*	Select this to switch between LSP and RSP.
FAILSAFE	Loop's output during a failure. -5% to +105%.
RATIO GAIN **	Gain value for a ratio loop. -20 to +20.
RATIO BIAS **	Local bias value in engineering units. -99999 to +99999. Enterable only if it is configured for local bias. It is read-only if it is configured for remote bias.
MOTOR DEADBAND % ***	Value of adjustable deadband in %.
MOTOR TRAVERSE TIME (SEC) ***	Motor travel time in seconds.
HYSTERESIS****	Loop alarm's hysteresis. 0 to 10% of PV range.

Bold parameters are read-only.

* Visible for all Loop Types except A/M Bias.

** Visible only if Loop Type is PID, 3POS, or CARBON and Bias/Gain is configured.

*** Visible only if Loop Type is 3POS.

**** Visible only if Loop Type is ON/OFF.



TIP

- Entry of Local Setpoint will be ignored by the controller if tracking is on and if the loop is in Manual mode.
 - Ratio Bias is enterable only if it is configured for local bias. It is read-only if it is configured for remote bias.
-

Carbon parameters

This display lets you adjust various carbon loop factors.

CARBON LOOP SETUP	
LOOPTAG1	AUTO LSP ENGU
FURNACE FACTOR	1234567
ANTI-SOOTING	ON
% HYDROGEN	1234567
% CO	1234567

Figure 47 Carbon loop setup

Table 30 Details of carbon loop

Feature	Description
Loop mode	See Table 24 for details. To change between AUTO and MAN modes, press Auto/Manual.
FURNACE FACTOR	Lets you adjust the % Carbon as measured by the controller to agree with the results of actual shim stock tests. This adjustment may be needed to correct for specific furnace characteristics such as atmosphere differences, probe location, and furnace leaks.
ANTI-SOOTING	Lets you adjust the anti-sooting factor, which limits the %C working setpoint of the downstream control block to a value which will not permit sooting to occur in the furnace. When anti-sooting is ON, then the anti-sooting factor is calculated as a linear translation of probe temperature to %C clamped at 0.75% and 2.0%. When anti-sooting is OFF, then the factor is fixed at 2.0% for all temperatures.
% HYDROGEN	Lets you adjust % HYDROGEN, one of the factors in the dewpoint calculation. The dewpoint calculation is a function of the mV input (IN) from the oxygen probe, temperature of the probe, and %H. The equations used are probe-type dependent and are supplied by the manufacturer.
% CO	Lets you adjust % Carbon measurement to compensate for variations in the amount of CO in the carrier gas. This value is changeable only if it is configured as a number. It is read-only if it is connected to a function block within the configuration.



TIP

- Carbon Parameters are visible only for Carbon loop types.
- The OI will prompt you to change the controller Mode if it is not already in the Program mode.

Loop alarm setpoints

This display shows the loop's setpoints and alarm types. A loop can have two alarms; and each loop alarm can have two setpoints and types.

LOOP ALARM SETPTS	
LOOPTAG1	AUTO LSP ENGU
ALARM1 TYPE1	PV HIGH
ALARM1 SP1	1234567
ALARM1 TYPE2	PV LOW
ALARM1 SP2	1234567
ALARM2 TYPE1	DEV HIGH
ALARM2 SP1	1234567
ALARM2 TYPE2	DEV LOW
ALARM2 SP2	1234567
ALARM HYSTERESIS	1234567

Figure 48 Loop alarm setpoints

Table 31 Details of loop alarm setpoints

Feature	Description
Loop mode	See Table 24 for details. To change between AUTO and MAN modes, press Auto/Manual.
ALARM 1 SETPOINT 1	The value at which the alarm will activate.
ALARM 1 TYPE 1	No Alarm PV High - Alarm when PV is greater than the alarm setpoint PV Low - Alarm when PV is less than the alarm setpoint Dev High - Alarm when PV - SP is greater than the alarm setpoint. Dev Low - Alarm when SP - PV is greater than the alarm setpoint. SP High - Alarm when SP is greater than the alarm setpoint SP Low - Alarm when SP is less than the alarm setpoint Out High - Alarm when output is greater than the alarm setpoint Out Low - Alarm when output is less than the alarm setpoint
ALARM 1 SETPOINT 2	same as Alarm 1 Setpoint 1
ALARM 1 TYPE 2	same as Alarm 1 Type 1
ALARM 2 SETPOINT 1	same as Alarm 1 Setpoint 1
ALARM 2 TYPE 1	same as Alarm 1 Type 1
ALARM 2 SETPOINT 2	same as Alarm 1 Setpoint 1
ALARM 2 TYPE 2	same as Alarm 1 Type 1

Feature	Description
ALARM HYSTERESIS	<p>Affects the point at which an alarm clears. For Out High and Out Low alarms, hysteresis is % of the loop's output span. For all other alarm types, it is % of PV span.</p> <p>PV High - Alarm clears when PV is less than the alarm setpoint by the amount of hysteresis.</p> <p>PV Low - Alarm clears when PV is greater than the alarm setpoint by the amount of hysteresis.</p> <p>SP High - Alarm clears when SP is less than the alarm setpoint by the amount of hysteresis.</p> <p>SP Low - Alarm clears when SP is greater than the alarm setpoint by the amount of hysteresis.</p> <p>Out High - Alarm clears when output is less than the alarm setpoint by the amount of hysteresis.</p> <p>Out Low - Alarm clears when output is greater than the alarm setpoint by the amount of hysteresis.</p> <p>Dev High - Alarm clears when PV - SP is less than the alarm setpoint by the amount of hysteresis.</p> <p>Dev Low - Alarm clears when SP - PV is less than the alarm setpoint by the amount of hysteresis.</p>



TIP

These Loop Alarm parameters are used to set the *conditions* under which loop alarms occur; they do not generate the alarm. To generate the alarm, loop alarms must be configured in an Alarm Group. If a loop alarm is not assigned to an alarm group, it will not be generated. See *Alarms* section.

Loop limits

This display shows all limits related to the selected loop.

LOOP LIMITS		
LOOPTAG1	AUTO LSP	ENGU
SP HIGH LIM		1234567
SP LOW LIM		1234567
SP RATE UP		1234567
SP RATE DOWN		1234567
PV HIGH LIM		1234567
PV LOW LIM		1234567
OUT HIGH LIM		1234567
OUT LOW LIM		1234567

Figure 49 Loop limits

Table 32 Details of loop limits

Feature	Description
Loop mode	See Table 24 for details. To change between AUTO and MAN modes, press Auto/Manual.
SP HIGH LIM*	Highest allowable setpoint value. -99999 to +99999.
SP LOW LIM*	Lowest allowable setpoint value. -99999 to +99999.
SP RATE UP LIM*	Highest allowable rate at which a setpoint changes to a higher value. 0 to 9999 units/minute.
SP RATE DOWN LIM*	Highest allowable rate at which a setpoint changes to a lower value. 0 to 9999 units/minute.
PV HIGH LIM	Highest allowable PV value. -99999 to +99999
PV LOW LIM	Lowest allowable PV value. -99999 to +99999
OUT HIGH LIM**	Highest allowable loop output value. -5 to +105%
OUT LOW LIM**	Lowest allowable loop output value. -5 to +105%
AUTOTUNE OUT HIGH LIM***	Highest value of the output beyond which the motor no longer affects the process.
AUTOTUNE OUT LOW LIM***	Lowest value of the output beyond which the motor no longer affects the process.



* Visible for all Loop Types except A/M Bias.

** Visible only if Loop Type is PID or CARBON

*** Visible only if Loop Type is 3POS

Loop Operation Displays

Overview

Loop operation displays are accessed under the Display keys  through  (through 8 for Model 1041). A variety of loop operation displays is available for your use to fit your application. Selection of display formats is performed using the Control Builder. All available displays are described in this section.

Loop modes (all loop displays)

All loop displays indicate the current operating mode of the selected loop. Loop modes are described in Table 33.

Table 33 Loop modes

Loop mode	Meaning
AUTO RSP	Loop is controlling the process and Remote Setpoint is selected.
MAN RSP	Loop output can only be changed manually. Remote Setpoint is selected.
IMAN RSP	IMAN (Initialization Manual) occurs with Cascade loops only (Figure 40). Secondary Cascade is in MAN or LSP, therefore Primary Cascade output is tracking Secondary Cascade's PV. Remote Setpoint is selected.
LO RSP	LO (Local Override): loop output is tracking the loop's Output Tracking value. Remote Setpoint is selected.
AUTO LSP	Loop is controlling the process and Local Setpoint is selected.
MAN LSP	Loop output can only be changed manually. Local Setpoint is selected.
IMAN LSP	IMAN (Initialization Manual) occurs with Cascade loops only (Figure 40). Secondary Cascade is in MAN or LSP, therefore Primary Cascade output is tracking Secondary Cascade's PV. Local Setpoint is selected.
LO LSP	LO (Local Override): loop output is tracking the loop's Output Tracking value. Local Setpoint is selected.



TIP

In the Control Builder, loops can be configured to display a specific number of decimal places for their values. A higher number of decimal places allows more precision; conversely, it limits whole numbers to the number of digits remaining to the left of the decimal point. In cases where the desired whole number is larger than can fit in the available digits, the decimal point will be moved to accommodate the new whole number. In other words, the need to enter a larger whole number takes precedence over the need for extra decimal places.

A maximum of 7 digits can be displayed, including whole numbers and decimal places.

Example

Loop's Set Point High Limit = 5000

Decimal places = 4 (therefore, $7 - 4 = 3$ digits available for whole numbers)

On a loop operation display, operator wants to enter a setpoint value of 2000, a 4-digit whole number. This is one more digit than allowed by the decimal place setting. Result: The decimal place setting of 4 is ignored to allow the value of 2000 to be entered.

See also

While performing loop operations, messages may be displayed. See Table 119 for message descriptions.

Eight loop summary - Model 551/552

The Eight Loop Summary lists an overview of up to 8 control loops.

LOOP SUMMARY					11:30
	MODE	PV	SP	OUT	
LOOP TAG1	MAN LSP	1234567	1234567	100.	
LOOP TAG2	AUTO RSP	2000.	2000.	50.	
LOOP TAG3	AUTO LSP	2000.	2000.	50.	
LOOP TAG4	AUTO RSP	2000.	2000.	50.	
LOOP TAG5	AUTO RSP	2000.	2000.	50.	
LOOP TAG6	AUTO LSP	2000.	2000.	50.	
LOOP TAG7	MAN LSP	2000.	2000.	50.	
LOOP TAG8	MAN LSP	2000.	2000.	50.	

Figure 50 Eight loop summary

Table 34 Details of Eight loop summary

Feature	Description
Mode	See Table 33. To change loop mode between AUTO and MAN, press Auto/Manual.
Number of loops	Up to 8 loops
LOOP TAG	Name of the loop. Press Tab to move to the desired loop tag and press Enter to go to the Loop Control Display of that loop (Figure 52).
PV	Value of process variable
SP	Value of setpoint. Press Detail to move to this and adjust the value.
OUT	Value of output. Press Detail to move to this and adjust the value. Loop must be in MAN first.

Bold items are read-only.

Sixteen loop summary - Model 1041

The Sixteen Loop Summary lists an overview of up to 16 control loops.

LOOP SUMMARY					11:30
	MODE	PV	SP	OUT	
LOOP TAG1	MAN LSP	1234567	1234567	100.	
LOOP TAG2	AUTO RSP	2000.	2000.	50.	
LOOP TAG3	AUTO LSP	2000.	2000.	50.	
LOOP TAG4	AUTO RSP	2000.	2000.	50.	
LOOP TAG5	AUTO RSP	2000.	2000.	50.	
LOOP TAG6	AUTO LSP	2000.	2000.	50.	
LOOP TAG7	MAN LSP	2000.	2000.	50.	
LOOP TAG8	MAN LSP	2000.	2000.	50.	
LOOP TAG16	MAN LSP	2000.	2000.	50.	

Model 1041 has
16 Loops per page

Figure 51 Sixteen loop summary

Table 35 Details of Sixteen loop summary

Feature	Description
Mode	See Table 33. To change loop mode between AUTO and MAN, press Auto/Manual.
Number of loops	Up to 16 loops
LOOP TAG	Name of the loop. Press Tab to move to the desired loop tag and press Enter to go to the Loop Control Display of that loop (Figure 52).
PV	Value of process variable
SP	Value of setpoint. Press Detail to move to this and adjust the value.
OUT	Value of output. Press Detail to move to this and adjust the value. Loop must be in MAN first.

Bold items are read-only.

Loop control

This display is accessible from all loop operating displays.

LOOP CONTROL	
LOOPTAG1	AUTO LSP ENGU
TYPE	PID
PV	1234567
OUTPUT	1234567
LOCAL SP	1234567
REMOTE SP	1234567
SWITCH SP	
RATIO GAIN	1234567

Figure 52 Loop control

Table 36 Loop control details

Feature	Description
Mode	See Table 33. To change loop mode between AUTO and MAN, press Auto/Manual.
TUNE	When this is visible, Loop is being tuned automatically. See <i>Loop Autotune (page 71)</i> .
TYPE	Choices: PID, ON/OFF, CARBON, 3 POS, A/M/BIAS
PV	Value of Process Variable
OUTPUT	Value of output
LOCAL SP	Value of Local Setpoint
REMOTE SP	Value of Remote Setpoint
SWITCH SP	Select this to switch loop setpoint between Remote and Local.
RATIO GAIN	Value of Ratio Gain. Appears for ratio loops only.

Bold items are read-only.

8 loop faceplate (Model 1041)

This display shows 8 loops in an easy-to-read process loop faceplate format. Select any loop tag to go to the Loop Control display for details on that loop (Figure 52). Press Tab and Detail to move cursor around the display.

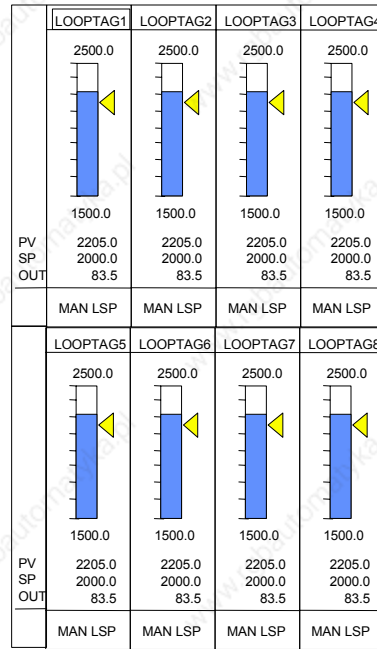

Figure 53 8 loop faceplate

Table 37 8 loop faceplate details

Feature	Description
Mode	See Table 33. To change loop mode between AUTO and MAN, press Auto/Manual.
Loop Tag	Name of the loop. Tab to the desired loop tag and press Enter to go to the Loop Control Display (Figure 52). Tab to the desired loop tag and press Detail to move cursor to the SP and OUT fields. Press Tab again to move cursor to next loop tag.
Vertical Bar	Graphically shows value of Process Variable within its range.
2500	High scale value of the PV.
1500	Low scale value of the PV.
Arrow	Graphically shows value of Setpoint
PV	Value of Process Variable
SP	Value of Setpoint. You can change this value.
OUT	Value of Output. You can change this only if loop is in MAN.

Bold items are read-only.

4 loop faceplate

This display shows 4 loops in an easy-to-read process loop faceplate format. Select any loop tag to go to the Loop Control display for details on that loop (Figure 52). Press Tab and Detail to move cursor around the display.

	LOOPTAG1	LOOPTAG2	LOOPTAG3	LOOPTAG4
	2500.0	2500.0	2500.0	2500.0
	1500.0	1500.0	1500.0	1500.0
PV	2205.0	2205.0	2205.0	2205.0
SP	2000.0	2000.0	2000.0	2000.0
OUT	83.5	83.5	83.5	83.5
	MAN LSP	MAN LSP	MAN LSP	MAN LSP

Figure 54 4 loop faceplate

Table 38 4 loop faceplate details

Feature	Description
Mode	See Table 33. To change loop mode between AUTO and MAN, press Auto/Manual.
Loop Tag	Name of the loop. Tab to the desired loop tag and press Enter to go to the Loop Control Display (Figure 52). Tab to the desired loop tag and press Detail to move cursor to the SP and OUT fields. Press Tab again to move cursor to next loop tag.
Vertical Bar	Graphically shows value of Process Variable within its range.
2500	High scale value of the PV.
1500	Low scale value of the PV.
Arrow	Graphically shows value of Setpoint
PV	Value of Process Variable
SP	Value of Setpoint. You can change this value.
OUT	Value of Output. You can change this only if loop is in MAN.

Bold items are read-only.

3 loop faceplate

This display shows 3 loops in an easy-to-read process loop faceplate format. Select any loop tag to go to the Loop Control display for details on that loop (Figure 52). Press Tab and Detail to move cursor around the display.

LOOPTAG1	LOOPTAG2	LOOPTAG3
PV 2205.0 SP 2000.0 OUT 83.5	PV 2205.0 SP 2000.0 OUT 83.5	PV 2205.0 SP 2000.0 OUT 83.5
AUTO LSP	AUTO RSP	MAN LSP

Figure 55 3 loop faceplate

Table 39 3 loop faceplate details

Feature	Description
Mode	See Table 33. To change loop mode between AUTO and MAN, press Auto/Manual.
Loop Tag	Name of the loop. Tab to the desired loop tag and press Enter to go to <i>Loop control (page 82)</i> . Tab to the desired loop tag and press Detail to move cursor to the SP and OUT fields. Press Tab again to move cursor to next loop tag.
Vertical Bar	Graphically shows value of Process Variable within its range.
2500	High scale value of the PV.
1500	Low scale value of the PV.
Arrow	Graphically shows value of Setpoint
PV	Value of Process Variable
SP	Value of Setpoint. You can change this value.
OUT	Value of Output. You can change this value only if loop is in MAN.

Bold items are read-only.

2 loop faceplate

This display shows 2 loops in an easy-to-read process loop faceplate format. Select any loop tag to go to the Loop Control display for details on that loop (Figure 52). Press Tab and Detail to move cursor around the display.

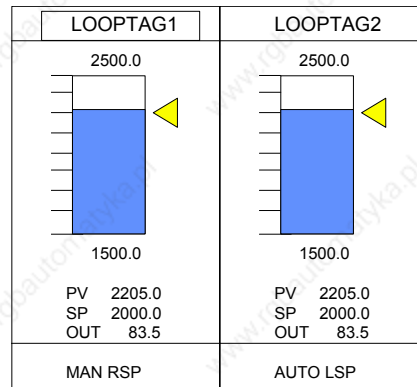

Figure 56 2 loop faceplate

Table 40 2 loop faceplate details

Feature	Description
Mode	See Table 33. To change loop mode between AUTO and MAN, press Auto/Manual.
Loop Tag	Name of the loop. Tab to the desired loop tag and press Enter to go to <i>Loop control</i> (page 82). Tab to the desired loop tag and press Detail to move cursor to the SP and OUT fields. Press Tab again to move cursor to next loop tag.
Vertical Bar	Graphically shows value of Process Variable within its range.
2500	High scale value of the PV.
1500	Low scale value of the PV.
Arrow	Graphically shows value of Setpoint
PV	Value of Process Variable
SP	Value of Setpoint. You can change this value.
OUT	Value of Output. You can change this value only if loop is in MAN.

Bold items are read-only.

1 loop numeric

This display shows the selected loop. Select the loop tag to go to the Loop Control display for details on the loop (Figure 52). Press Detail to go to the SP and OUT values.

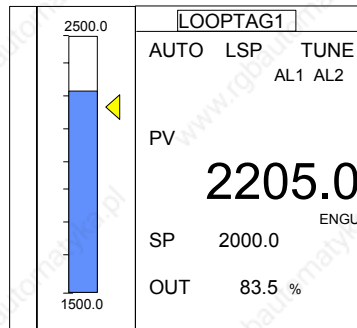

Figure 57 Single loop numeric

Table 41 Single loop numeric details

Feature	Description
Loop Tag	Name of the loop. Tab to the loop tag and press Enter to go to the Loop Control Display (Figure 52). Press the "TAB" key to move cursor to the SP and OUT fields.
Mode	See Table 33. To change loop mode between AUTO and MAN, press Auto/Manual.
LSP / RSP	Local Setpoint or Remote Setpoint indicator
TUNE	When this is visible, Loop is being tuned automatically. See <i>Loop Autotune (page 71)</i> .
AL1 AL2	Loop alarm indicators. See <i>Loop alarm setpoints (page 76)</i> for alarm setpoints.
PV	Value of Process Variable
SP	Value of Setpoint. You can change this value.
OUT	Value of Output. You can change this value only if loop is in MAN.

Bold items are read-only.

Single loop faceplate with loop trend screen

This operate display shows the selected loop in a single loop faceplate format with a loop trend screen. For details, press ENTER at this display to call up the “Loop Control” display (page 89). From there the first menu item calls up the “Loop Tune Constants” display (page 90).

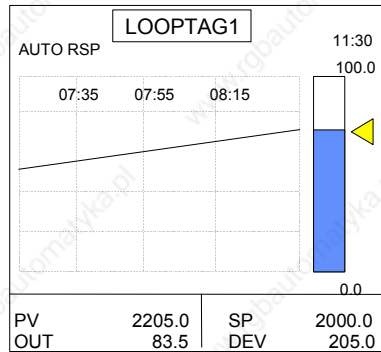



Figure 58 Single loop faceplate with loop trend screen

Table 42 Details of single loop faceplate with loop trend screen

Feature	Description
Loop mode	See Table 24 for details
Loop Tag	Indicates tag number assigned to loop. Press ENTER from this display to select “Loop Control” display (page 89)
	Setpoint of the loop.
PV bar graph on right side	Current value of PV
PV value at lower left	Current value of PV
PV trend	Shows PV over the last timebase. Timebase can be changed in the “Loop Tune Constants” operate display.
OUT	Value of loop output. Can be changed when loop is in MAN mode.
SP	Setpoint value. To change, see the “Loop Control” operate display.
DEV	PV’s deviation from setpoint.

Bold items are read-only.



TIP

This display is not available for ON/OFF control type.

Loop Control display

This operate display lets you edit the Local Setpoint, switch Setpoints or read the Remote Setpoint.

LOOP CONTROL	
LOOPTAG1	AUTO LSP EU
TYPE	PID
PV	1234567
OUTPUT	1234567
LOOP TUNE CONSTANTS	
LOCAL SP	1234567
REMOTE SP	1234567
SWITCH SP	

Figure 59 Loop control display

Table 43 Loop control display details

Feature	Description
Mode	See Table 33.
Loop Tag	Indicates tag number assigned to loop. Press ENTER from this display to select "Loop Control" display (page 89)
EU	Engineering Units
TYPE	Choices: PID, ON/OFF, CARBON, 3 POS, A/M BIAS
PV	Value of Process Variable
OUTPUT	Value of output
LOOP TUNE CONSTANTS	Press "ENTER" to call up "Loop Tune Constants" display. Page 90
LOCAL SP	Value of Local Setpoint. Press ENTER, then UP or DOWN to change. Press ENTER again.
REMOTE SP (Read Only)	Value of Remote Setpoint
SWITCH SP	Select this to switch loop setpoint between Remote and Local. Press ENTER, then UP or DOWN to change. Press ENTER again.
RATIO GAIN	Value of Ratio Gain. Appears for ratio loops only.

Bold items are read-only.

Loop Tune Constants display

This display shows the tuning constants for the selected loop.

LOOP TUNE CONSTANTS	
LOOPTAG1	AUTO LSP ENGU
GAIN#1	1234567
RESET#1 MINS	1234567
RATE#1	1234567
GAIN#2	1234567
RESET#2 MINS	1234567
RATE#2	1234567
FEEDFORWARD GAIN	1234567
MANUAL RESET	1234567
SET TIMEBASE	30 MIN

Figure 60 Loop tune constants display

Table 44 Details of loop tune constants display

Feature	Description
GAIN #1 OR #2 *	Gain is the ratio of the output change (%) over the measured variable change (%) that caused it. Gain = 100/Proportional Band
PROPORTIONAL BAND (PB) # 1 OR #2 *	PB is the percent of the range of the measured variable for which a proportional controller will produce a 100% change in its output.
RATE #1 OR #2	Rate affects the controller's output whenever the deviation is changing; and affects it more when the deviation is changing faster.
RESET #1 OR #2	Reset, or integral time, adjusts the controller's output according to the size of the deviation (SP - PV) and the time it lasts. The amount of corrective action depends on the value of Gain. Reset is measured as how many times proportional action is repeated per minute (repeats/minute) or how many minutes before one repeat of the proportional action occurs (minutes/repeat).
FEEDFORWARD GAIN**	Applies Gain to the feedforward variable (FFV).
MANUAL RESET**	Manual Reset is only applicable if you do not use Reset. It allows correction of output to account for load changes to bring the PV up to setpoint.
SET TIMEBASE	Determines the time axis of the loop trend display: 5 minutes (Model 551/552 only), 15, 30 minutes, 1, 2, 4, 24, or 8 hours. See <i>Loop trend (page 70)</i> for details.

*Either Gain or PB is visible but not both. Visibility is selectable with the Control Builder.

**Visible only if Loop Type is PID or CARBON.



TIP

- You can also access this screen from the Loop Trend (page 70). Pressing Escape will return you to the "Loop Control" screen, preserving the buffered trend data.

A/M bias

This display lets you assign a bias to the loop PV. That is, $OUT = PV + BIAS$ while loop is in AUTO.

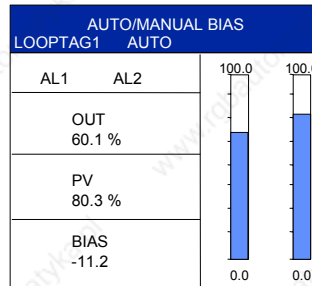

Figure 61 A/M bias

Table 45 A/M bias details

Feature	Description
Mode	See Table 33. To change loop mode between AUTO and MAN, press Auto/Manual.
AL1 & AL2	Loop alarm indicators visible while the loop alarm conditions are active.
Loop Tag	Name of the loop. Press Tab to move to OUT.
OUT	0-100 %. To adjust the output (and therefore the bias), select MAN mode, then adjust with Increment or Decrement. Bias (OUT – PV) is calculated at the moment of transition from MAN to AUTO.
PV	Value of Process Variable. 0-100 %
BIAS	Bias = OUT – PV. Range: –100 % to +100 %. Bias is calculated at the moment of transition from MAN to AUTO.
Left vertical bar	Output
Right vertical bar	PV

Bold items are read-only.

Setpoint Programmers

Overview

Setpoint programmers produce a setpoint output on a time-based profile. This setpoint output is typically used as the setpoint of a control loop.

Up to 4 programs can be running concurrently. Each program may be from 2 to 50 segments in length. Each segment of the program may be a ramp or soak except the last segment must be a soak.

From 1 to 4 programmers can run any of the 70 profiles in controller memory. Once loaded from memory into the Setpoint Programmer (SPP) function, these profiles are referred to as “programs.” Any program can be edited and saved as a profile in one of the 70 “slots” in the controller’s memory.

In addition to the main output value, a second analog value is available for each step of the program. This output is a fixed soak value which may be used as an input to another function or to provide a setpoint value for a secondary control loop in the process.

A Setpoint guarantee function (known as guaranteed hold) is provided that holds the program if a process variable exceeds a predefined deviation from setpoint. Selections allow setpoint guarantee to be active for the entire program, for soak segments only, or for user specified segments.

Up to 3 Process Variables may be configured as inputs to the block for setpoint guarantee.

The program may be changed (with some exceptions) from the current state to a new state by the operator as well as by inputs to the SPP block. Table 46 lists the resulting states.

Table 46 SPP inputs and current state

Input	Current State				
	READY	HOLD	RUN	GHOLD	STOP
RESET	READY	READY	RUN	READY	READY
HOLD	HOLD	HOLD	HOLD	HOLD	STOP
RUN	RUN	RUN	RUN	GHOLD	STOP
GHOLD	READY	HOLD	GHOLD	GHOLD	STOP

With regard to changing program state, if more than one function block input is on in the same execution cycle, RESET has priority over HOLD and RUN, and GHOLD has priority over RUN.

Also, function block inputs will override inputs from the Operator Panel which occur during the same execution cycle. Finally, state changes from the Operator Panel are processed on the basis of the “last change wins.”

Setpoint Program Setup

Setpoint Program setup is done through the SP Programmers menu, accessed through the Main Menu.

Access

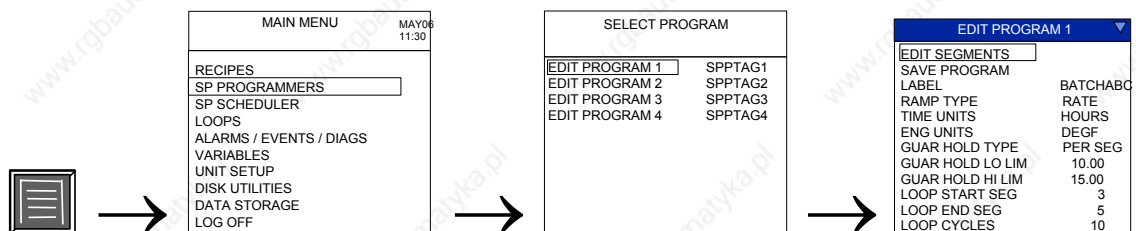

What's in this section

Topic	See Page
Select Program	94
Edit Program	95
Edit Program Segments	97
Edit Program Segment Events	99
Save Program	99

Select program

Select a program to edit. The Edit Program menu is then displayed.

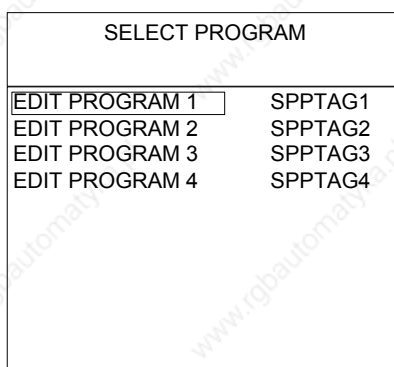

Figure 62 Select program



TIP

Program must be in READY to be edited.

See also

While operating Setpoint Programming functions, messages may be displayed. See Table 119 for message descriptions.

Edit program

This display lets you edit parameters of the selected program. Edits affect only the currently working program, not the profile in memory, unless you save the program.



ATTENTION

Program must be in READY state to be edited.

Model 551/552

EDIT PROGRAM 1	
EDIT SEGMENTS	
SAVE PROGRAM	
LABEL	BATCHABC
RAMP TYPE	RATE
TIME UNITS	HOURS
ENG UNITS	DEGF
GUAR HOLD TYPE	PER SEG
GUAR HOLD LO LIM	10.00
GUAR HOLD HI LIM	15.00
LOOP START SEGMENT	3
LOOP END SEGMENT	5
LOOP CYCLES	10

Model 1041

EDIT PROGRAM 1	
EDIT SEGMENTS	
SAVE PROGRAM	
LABEL	BATCHABC
RAMP TYPE	RATE
TIME UNITS	HOURS
ENG UNITS	DEGF
GUAR HOLD TYPE	PER SEG
GUAR HOLD LO LIM	10.00
GUAR HOLD HI LIM	15.00
LOOP START SEGMENT	3
LOOP END SEGMENT	5
LOOP CYCLES	10
JOG SEGMENT	10
RESTART RATE	50.00
AUX OUT LABEL	HUMIDITY
AUX ENG UNITS	PCT
FASTFORWARD	OFF

Figure 63 Edit program

Table 47 Edit program details

Feature	Description
EDIT SEGMENTS	Accesses Edit Segments menu (Figure 64) where you can edit each segment.
SAVE PROGRAM	Saves changes you make to this display. Program is saved in the controller's profile memory where it can be loaded and run later.
LABEL	Identifies the program with text.
RAMP TYPE	<p>TIME: Each ramp segment's time is the TIME allotted to the profile's output to reach the next soak segment's value in hours or minutes.</p> <p>OR</p> <p>RATE: Each ramp segment's time specifies the RATE at which that profile's output will reach the next soak segment, where the rate is specified in EU/hour or EU/minute.</p> <p>Make this selection before entering any Ramp during Profile Edit.</p> <p>NOTE: When Ramp unit is configured for TIME, entering "0" will imply an immediate step change in setpoint to the next soak.</p>

Feature	Description
TIME UNITS	<p>This selection assigns the time units (hours or minutes) for the ramp type selected.</p> <p>For Time ramp type: Time = Hours or Minutes</p> <p>For Rate ramp type: Rate = EU/Hour or EU/Minutes</p>
ENG UNITS	Engineering Units of the PV
GUAR HOLD TYPE	<p>Guaranteed Hold, if enabled here, will hold the profile value if a PV to the profile (typically a control loop's PV) deviates specified amounts above or below the profile output.</p> <p>None: No segments have guaranteed hold enabled.</p> <p>Per Seg: Lets you select specific segments for guaranteed hold where you set up the profile ramps and soaks.</p> <p>All Soaks: All soak segments will have a guaranteed hold enabled.</p> <p>All Segs: All segments will have guaranteed hold enabled.</p>
GUAR HOLD LO LIM	The profile will hold if a PV deviates more than this amount below the profile setpoint.
GUAR HOLD HI LIM	The profile will hold if a PV deviates more than this amount above the profile setpoint.
LOOP START SEGMENT	The first segment of the loop.
LOOP END SEGMENT	The last segment of the loop.
LOOP CYCLES	Number of times the loop segments will execute. Zero (0) means the segments will be repeated forever.
JOG SEGMENT	Segment to which the program will jump to when the JOG discrete input is pulsed.
RESTART RATE	This recovery ramp rate is provided in the event of a power loss while a program is running. The Restart Rate value is used to return the process to the last operating setpoint prior to power loss.
AUX OUT LABEL	<p>A second analog value is available for each segment of the program. It is a fixed soak value and can be used to provide a setpoint value for a secondary control loop in the process.</p> <p>Enter up to 8 characters for the label.</p>
AUX ENG UNITS	Up to 4 characters. This is the engineering unit text associated with the AUX OUT.
FAST FORWARD	Fast Forward is a way to check for proper functioning of the profile's events and outputs, without having to wait for the profile to execute at its normal speed. When FAST FORWARD is ON, the program will run at a speed 60 times faster. When FAST FORWARD is OFF, the program will run at normal speed.

Edit segments

This menu lets you specify segment parameters.

SPP PROGRAM EDIT SEGMENT		SPP PROGRAM EDIT SEGMENT	
F1 - NEXT SEG	F2 - PREV SEG	F1 - NEXT SEG	F2 - PREV SEG
EDITING PROGRAM#	3 LABEL	EDITING PROGRAM#	3 LABEL
SEGMENT #	10	SEGMENT #	10
SEGMENT TYPE	RAMP	SEGMENT TYPE	RAMP
STARTING VALUE	1500.0	STARTING VALUE	1500.0
TIME / RATE	20.0	TIME / RATE	20.0
GUAR HOLD	OFF	GUAR HOLD	OFF
AUX START VALUE	30.0	AUX START VALUE	30.0
EVENT #1	LABEL	EVENT #9	LABEL
EVENT #2	LABEL	EVENT #10	LABEL
EVENT #3	LABEL	EVENT #11	LABEL
EVENT #4	LABEL	EVENT #12	LABEL
EVENT #5	LABEL	EVENT #13	LABEL
EVENT #6	LABEL	EVENT #14	LABEL
EVENT #7	LABEL	EVENT #15	LABEL
EVENT #8	LABEL	EVENT #16	LABEL

Model 551/552

Model 1041

Figure 64 Edit segment

Table 48 Edit segment details

Feature	Description
F1 – NEXT SEG	Select this to edit next segment.
F2 – PREV SEG	Select this to edit previous segment.
EDITING PROGRAM #	Number of program being edited (1-70) and its label.
SEGMENT #	Segment being edited (1-50).
SEGMENT TYPE	Ramp or Soak. Last segment must be a soak.
STARTING VALUE	Starting value of the segment.
TIME	Range = 0.00 hr. to 999.99 hr. or 0.00 min. to 999.99 min. The function of this value depends on the Ramp Type. See Table 47.
GUAR HOLD	Select ON to enable setpoint guarantee if GHOLD is Per Segment.
AUX START VALUE	Select a fixed soak value for this segment.
EVENTS	<p><i>Model 551/552:</i> Select "EVENTS" to access the Edit Segment Events menu (Figure 65).</p> <p><i>Model 1041:</i> Edit the segment events on this display.</p>



TIP

- Edits are allowed to any segment of the program, including the current segment.
 - If edit is to current segment and segment is a ramp:
 - If the ramp type is edited, then the time remaining is recalculated and the ramp rate is adjusted accordingly.
 - If the ramp rate is edited, then the time remaining is adjusted accordingly.
 - Changes to the ramp starting setpoint will be ignored for the current execution of the segment, but will be used for subsequent execution if the segment is included in a loop.
 - If edit is to current segment and segment is a soak:
 - Changes to the soak setpoint will result in a step change.
 - Changes to the time will cause recalculation of the segment time remaining. If the result is less than or equal to 0, the program will advance to the next segment upon returning to RUN state.
 - If the current segment is a ramp and the starting value of the following segment is changed, then the time remaining in the ramp segment will be adjusted accordingly but the ramp rate will remain unchanged.
 - Edits to soak setpoints will result in a step change at the next segment unless the starting value of that segment is changed to the same value as well.
-

Edit segment events (Model 551/552)

EDIT SEGMENT EVENTS	
EVENT # 1	OFF
EVENT # 2	ON
EVENT # 3	OFF
EVENT # 4	OFF
EVENT # 5	OFF
EVENT # 6	OFF
EVENT # 7	OFF
EVENT # 8	OFF
EVENT # 9	OFF
EVENT #10	OFF
EVENT #11	OFF
EVENT #12	OFF

Figure 65 Edit segment events

Description

You can configure 1 to 16 segment events to turn ON or OFF at the beginning of each segment. Segment events are digital switches that provide ON/OFF outputs. When a segment event is turned ON, it remains ON until the end of the segment at which time it is turned OFF unless it is configured to turn ON in the next segment. Note that segment events are not interrupted by soak time delays when the process variable is outside the guaranteed soak band. Events turn ON as soon as the previous segment is completed even if the process variable has not reached the soak setpoint.

Table 49 Edit segment events details

Feature	Description
EVENT #1 – 16	ON or OFF



TIP

Events can be edited only while program is in READY state.

Save program

This function saves a program to the controller's profile memory. From 1 to 4 programmers can run any of the 70 profiles in controller memory. Once loaded from controller memory into the Setpoint Programmer function, these profiles are known as programs. You can choose to save a program (profile) back to controller memory after editing it. See Figure 67.

SAVE PROGRAM 2	
CURRENT PROFILE NUMBER	3
SAVE TO PROFILE NUMBER	10

Figure 66 Save program

Up to 70 Profiles in RAM

Profile #1
Profile #2
Profile #3
.
.
Profile #70

1 Profile #3 was previously loaded into SP Program #1.

SP PROGRAMMER SPTAG1 11:30

LABEL678

STATE PROF SEG RAMP

READY # 3 # 1

PRIMARY AUXLABEL

ENGU ENGU

PV 1450.0 31.0

SP 1449.0 31.1

SEG TIME REM 01:30:00

PGM ELAPSED TIME 00:00:00

LOAD

MORE COMMANDS

F1 RUN

F2 HOLD

F3 RESE

F4 ADV

SP PROGRAMMER SPTAG1 11:30

LABEL678

STATE PROF SEG RAMP

RUN # 3 # 2

PRIMARY AUXLABEL

CLEAR ENGU

ADVANCE

VIEW EVENTS

VIEW DETAIL

EDIT

SAVE

MORE C

F1 RUN

F2 HOLD

F3 RESE

F4 ADV

2 Select MORE COMMANDS... ...then select SAVE.

3 Program #1 is saved as Profile #2 in RAM

Profile #1
Profile #2
Profile #3
.
.
Profile #70

4 Select SAVE TO PROFILE NUMBER 2

SAVE PROGRAM 1	
CURRENT PROFILE NUMBER	3
SAVE TO PROFILE NUMBER	2

5 Program #1 now contains Profile #2.

SP PROGRAMMER SPTAG1 11:30

LABEL678

STATE PROF SEG RAMP

READY # 2 # 2

PRIMARY AUXLABEL

ENGU ENGU

PV 1450.0 31.0

SP 1449.0 31.1

SEG TIME REM 01:30:00

PGM ELAPSED TIME 00:00:00

LOAD

MORE COMMANDS

F1 RUN

F2 HOLD

F3 RESE

F4 ADV

Figure 67 Example of saving a program

Table 50 Program save details

Feature	Description
CURRENT PROFILE NUMBER	Shows the profile # currently loaded as a program.
SAVE TO PROFILE NUMBER	There are 70 “slots” available in memory for profiles. ATTENTION: You will overwrite any profile in the slot. Select the desired slot and press Enter to save the profile. The profile is also saved in the program.

Setpoint Program Operation

Overview

Setpoint program operation displays are accessed under the Display keys **1** through **5** (through 8 for Model 1041). A variety of setpoint program operation displays is available for your use to fit your application. Selection of display formats is performed using the Control Builder. All available displays are described in this section.

See also

While performing setpoint program operations, messages may be displayed. See Table 119 for message descriptions.

What's in this section

Topic	See Page
Single SP Program Operation - Model 551/552	102
Single SP Program Operation - Model 1041	104
Load Program	106
Operate Popup Menu (More Commands) - 551/552 only	108
View Program Events - Model 551/552	109
View Program Details -- Model 551/552	110
Edit Segments	111

Security

When Security is enabled (see “Set Security”), the SPP operate display works as follows:

When the display is initially called, the security pop-up appears. Enter the proper security code then re-select the function. Access is permitted without further interruption of the security pop-up until the display is removed from view

Single SPP operation - Model 551/552









This display shows live values of a setpoint programmer.

SP PROGRAMMER SPTAG1				11:30
LABEL678				
STATE	PROF	SEG	RAMP	F1 RUN
RUN	# 3	# 2		F2 HOLD
	PRIMARY	AUXLABEL		F3 RESET
	ENGU	ENGU		F4 ADV
PV	1450.0	31.0		
SP	1449.0	31.1		
SEG TIME REM	01:30:00			
PGM ELAPSED TIME	00:00:00			
LOAD				
MORE COMMANDS				

Figure 68 Single SPP operation - Model 551/552

Table 51 Single SPP details - Model 551/552

Feature	Description
LABEL678	Name of the selected profile.
STATE	READY: Profile is at the beginning of segment and is ready to run. All events are OFF. HOLD: Profile is paused at the setpoint value shown. RUN: Profile is executing normally. GHOLD: Profile is paused because of excessive deviation. STOP: Profile has reached the end of the last segment.
PROF	Profile # is the memory location, 1 to 70, of this profile.
SEG	Current segment
RAMP or SOAK	Type of current segment: ramp or soak

Feature	Description
	<p>Current segment, next segment indicators.</p> <p>Left box: current segment type.</p> <p>Right box: next segment type.</p> <p> Ramp up</p> <p> Soak</p> <p> Ramp down</p> <p> Blank</p> <p>In Ready state, there are no segment type boxes displayed.</p>
PRIMARY PV	Value of PV.
PRIMARY SP	Value of setpoint.
AUXILIARY PV (AUX LABEL)	Value of auxiliary PV.
AUXILIARY SP (AUX LABEL)	Value of auxiliary setpoint.
SEG TIME REM	Time remaining in the indicated segment.
PGM ELAPSED TIME	Time elapsed in RUN, HOLD, and GHOLD states.
LOAD	Accesses the Load Program display. See Load program (page 106). Program must be in READY state.
MORE COMMANDS	Accesses the Popup Operate menu. See <i>SPP operate popup menu</i> (page 108).
	Push F1 button to start a program that is in HOLD or READY state.
	Push F2 button to put program in HOLD.
	Push F3 button to reset a HOLD or STOP program to the first segment. Any edits made to the program are lost unless they were SAVED. See SAVE on the popup menu (Figure 73).
	Causes program to jump to the next segment. Programs in the last segment will jump to the end of the program. Programs cannot be advanced to the first segment.

Bold items are read-only.

Single SPP operation - Model 1041

This display shows live values of a setpoint programmer.









It includes SPP Operate details as well as Program Event details on one screen.

SP PROGRAMMER		SPTAG1		Date
STATE	PROF	SEG	SOAK	F1 RUN
RUN	# 3	# 2	—	
	PRIMARY	AUXLABEL		F2 HOLD
PV	1450.0	31.0		
SP	1449.0	31.1		F3 RESET
ELAPSED SEG TIME	00:30:00			
PGM ELAPSED TIME	02:00:00			F4 ADV
SEG TIME REMAIN	01:30:00			
PV2	0.0			
PV3	0.0			
LOAD	EV1 OFF	EV9 OFF		
CLEAR	EV2 OFF	EV10 OFF		
EDIT	EV3 OFF	EV11 OFF		
SAVE	EV4 OFF	EV12 OFF		
	EV5 OFF	EV13 OFF		
	EV6 OFF	EV14 OFF		
	EV7 OFF	EV15 OFF		
	EV8 OFF	EV16 OFF		
				RUN

Figure 69 Single SPP operation - Model 1041

Table 52 Single SPP details - Model 1041

Feature	Description
LABEL678	Name of the selected profile.
STATE	READY: Profile is at the beginning of segment and is ready to run. All events are OFF. HOLD: Profile is paused at the setpoint value shown. RUN: Profile is executing normally. GHOLD: Profile is paused because of excessive deviation. STOP: Profile has reached the end of the last segment.
PROF	Profile # is the memory location, 1 to 70, of this profile.
SEG	Current segment
RAMP or SOAK	Type of current segment: ramp or soak

Feature	Description
	<p>Current segment, next segment indicators. Left box: current segment type. Right box: next segment type.</p> <p>  Ramp up  Soak  Ramp down  Blank </p> <p>In Ready state, there are no segment type boxes displayed.</p>
PRIMARY PV	Value of PV.
PRIMARY SP	Value of setpoint.
ELAPSED SEG TIME	Time elapsed in the segment
ELAPSED PGM TIME	Time elapsed in RUN, HOLD, and GHOLD states.
SEG TIME REMAIN	Time remaining in the indicated segment.
PV2	Process Variable #2 value, for deviation check.
PV3	Process Variable #3 value, for deviation check.
LOAD	Accesses the Load Program display. See Load program(<i>page 106</i>). Program must be in READY state.
CLEAR	Erases the program from the programmer. Program must be in READY state. Do not clear a program if you need to save it first.
EDIT	Displays the Edit Segment menu. See <i>Edit segments (page 111)</i> . Program must be in READY, HOLD, or STOP state.
SAVE	Accesses the Save Program display (Figure 66). Program must be in READY, HOLD, or STOP state.
EVENT #	State of 16 events associated with this segment. ON or OFF.
	Push F1 button to start a program that is in HOLD or READY state.
	Push F2 button to put program in HOLD.
	Push F3 button to reset a HOLD or STOP program to the first segment. Any edits made to the program are lost unless they were SAVED. See SAVE on the display.
	Push F4 button to cause the program to jump to the next segment. Programs in the last segment will jump to the end of the program. Programs cannot be advanced to the first segment.

Bold items are read-only.

Load program

This menu lets you load a program from memory, using a profile number or selecting from a profile list, into a setpoint programmer where it can be run or edited.

LOAD PROFILE TO PGM 2	
CURRENT PROFILE NUMBER	3
	LABEL678
LOAD FROM PROFILE NUMBER	10
LOAD FROM PROFILE LIST	
SEGMENT NUMBER	5

Figure 70 Load program

Table 53 Program load details

Feature	Description
CURRENT PROFILE NUMBER	Number of program being run by the programmer (1-70).
LOAD FROM PROFILE NUMBER	Number of profile to be loaded from memory (1-70). Load profile number 0 (zero) will clear the working program.
LOAD FROM PROFILE LIST	Profile number selected from a list of profiles that appears will be loaded from memory.
SEGMENT NUMBER	After loading, the program will start at this segment. Subsequent runs will start at Segment #1. If the segment number is within a loop, the profile cycles through the looped segments according to the number of loop cycles.

Bold items are read-only.

Loading a profile from a profile number

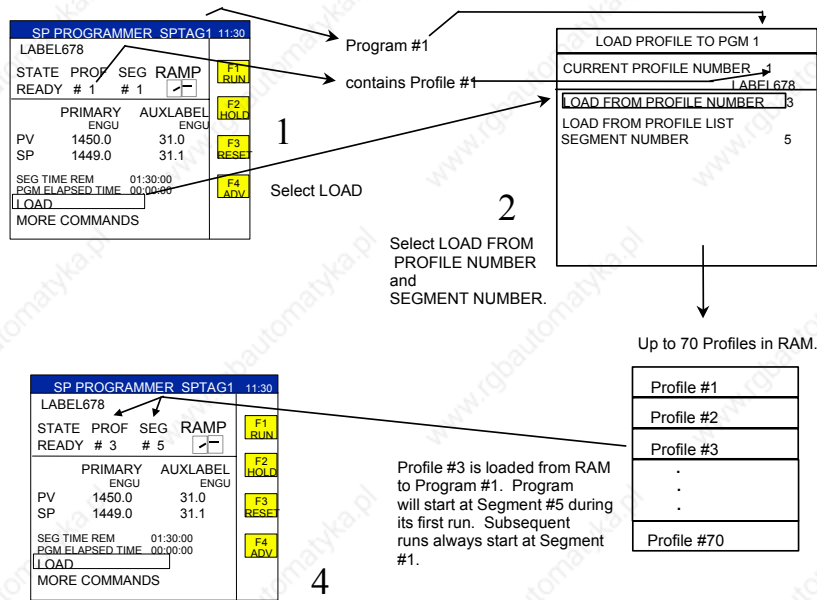

Figure 71 Example of loading a program from a profile number

Loading a profile from a profile list

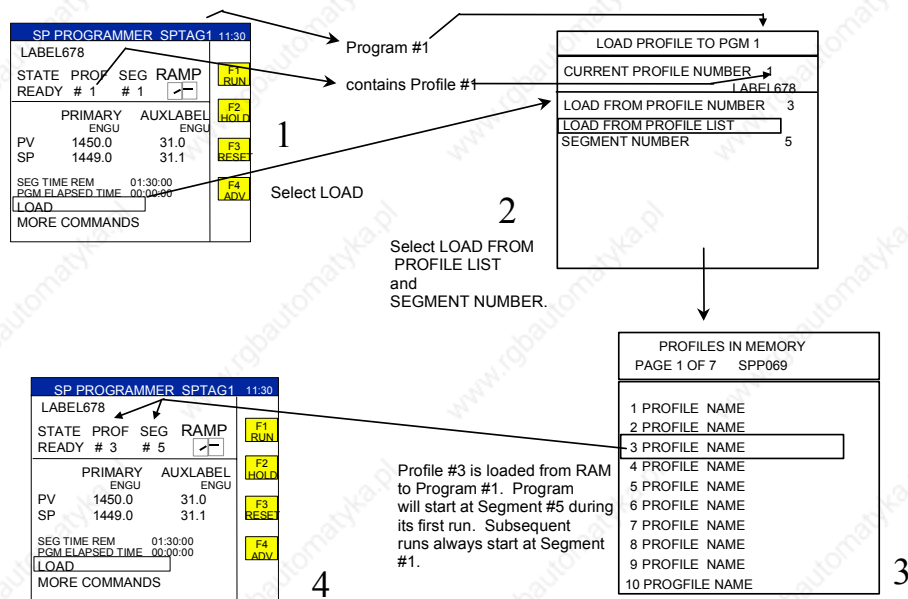

Figure 72 Example of loading a program from a profile list

SPP operate popup menu - Model 551/552 only

This menu lets you adjust and view parameters of the program. Some actions require the program to be in certain states (RUN, READY, etc.). See Table 55.

For Model 1041 Operate details - See Figure 69 "Single Setpoint Operation - Model 1041".

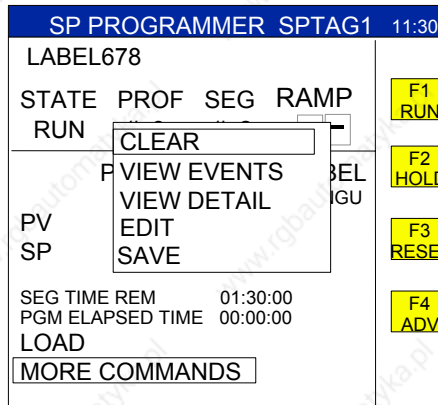

Figure 73 SPP operate popup menu - Model 551/552 only

Table 54 SPP operate details - Model 551/552 only

Feature	Description
CLEAR	Erases the program from the programmer. Program must be in READY state. Do not clear a program if you need to save it first.
VIEW EVENTS	Displays the status of 16 events associated with this segment. See <i>View program events (page 109)</i> .
VIEW DETAIL	Displays detailed information on the program. See <i>View program detail (page 110)</i> .
EDIT	Displays the Edit Segment menu. See <i>Edit segments (page 111)</i> . Program must be in READY, HOLD, or STOP state.
SAVE	Accesses the Save Program display (Figure 66). Program must be in READY, HOLD, or STOP state.

In the following table, X indicates the action can be performed when the program is in that state. NA means the action is not available in that state.

Table 55 SPP popup menu actions according to state

Action	Program state				
	READY	RUN	HOLD	GHOLD	STOP
CLEAR	X	NA	NA	NA	NA
EDIT	X	NA	X	NA	X
SAVE	X	NA	X	NA	X

View program events - Model 551/552

This display lets you see the status of up to 16 events associated with each segment.

For Model 1041 Events - See Figure 69 "Single Setpoint Operation - Model 1041".

SP PROGRAMMER SPTAG1 11:30			
LABEL678			
STATE	PROF	SEG	RAMP
RUN	# 3	# 2	<input checked="" type="checkbox"/>
EVENT #1	OFF	EVENT #9	ON
EVENT #2	OFF	EVENT #10	OFF
EVENT #3	OFF	EVENT #11	ON
EVENT #4	ON	EVENT #12	ON
EVENT #5	OFF	EVENT #13	OFF
EVENT #6	ON	EVENT #14	ON
EVENT #7	OFF	EVENT #15	OFF
EVENT #8	OFF	EVENT #16	OFF
SEG TIME REM	0:00		

Figure 74 View program events - Model 551/552

Table 56 View program events details - Model 551/552

Feature	Description
LABEL678	Label of current program.
STATE	Current state of program.
PROF #	Number of profile (1-70)
SEG #	Current segment (1-50).
RAMP or SOAK	Segment type: Ramp or Soak
EVENT #	State of 16 events associated with this segment. ON or OFF.
SEG TIME REM	Time remaining in the segment

Bold items are read-only.

View program details - Model 551/552

This display lets you see details on the program time and auxiliary PVs.

For Model 1041 Program Details - See Figure 69 "Single Setpoint Operation - Model 1041".

SP PROGRAMMER SPTAG11:30	
LABEL678	
STATE PROF SEG RAMP	F1 RUN
RUN # 3 # 2	
PV 2	2207.23
PV 3	2203.92
ELAPSED SEG TIME	1:15:45
ELAPSED PGM TIME	10:36:01
SEG TIME REMAIN	0:45:15
SEGS TIME REMAIN 01:30:00	F4 ADV
PGM ELAPSED TIME 00:00:00	
LOAD	
MORE COMMANDS	

Figure 75 View program details - Model 551/552

Table 57 View program details- Model 551/552

Feature	Description
PV2	Process Variable #2 value, for deviation check.
PV3	Process Variable #3 value, for deviation check.
ELAPSED SEG TIME #	Time elapsed in the indicated segment.
ELAPSED PGM TIME #	Time elapsed in the program.
SEG TIME REMAIN	Time remaining in the indicated segment.

Bold items are read-only.

Edit segments

This menu lets you edit the profile segments of the working program. Edits do not affect profiles in memory unless you save them.



ATTENTION

Program must be in READY, HOLD, or STOP state before segments can be edited.

EDIT SEGMENTS	
F1 - NEXT SEG	F2 - PREV SEG
REFERENCE PROFILE	3 LABEL
SEGMENT #	10
SEGMENT TYPE	RAMP
TIME UNITS	MINS
RAMP TYPE	RATE
CANNOT EDIT IN THIS STATE	
STARTING VALUE	1500.0
TIME / RATE	20.0
AUX VALUE	80.5

Figure 76 Edit segments

Table 58 Edit segments details

Feature	Description
F1 - NEXT SEG	Select this to edit next segment.
F2 - PREV SEG	Select this to edit previous segment.
REFERENCE PROFILE # LABEL	Number and label of program being edited (1-70).
SEGMENT #	Segment being edited (1-50).
SEGMENT TYPE	Ramp or Soak
TIME UNITS	Time units of the profile. Minutes or Hours.
RAMP TYPE	TIME: Each ramp segment's time is the TIME allotted to the profile's output to reach the next soak segment's value in hours or minutes. OR RATE: Each ramp segment's time specifies the RATE at which that profile's output will reach the next soak segment, where the rate is specified in EU/hour or EU/minute.
STARTING VALUE	Starting value of the segment.
TIME/RATE	Range = 0.00 hr. to 999.99 hr. or 0.00 min. to 999.99 min. The function of this value depends on the Ramp Type.
AUX VALUE	Select a fixed soak value for this segment.

Setpoint Scheduler

Overview

A setpoint schedule produces multiple setpoint outputs on a common time base. A setpoint schedule contains up to 50 segments. Each segment contains up to 8 ramp or soak setpoints, up to 8 auxiliary soak outputs, and up to 16 events. The last segment setpoint must be a soak.

The Setpoint Scheduler can run any of the 10 schedules in controller memory. Any schedule can be edited and saved in one of the 10 “slots” in the controller’s memory.

A Setpoint guarantee function (known as guaranteed hold) is provided that holds the Scheduler if a process variable exceeds a predefined deviation from setpoint. Guaranteed hold is set on a per-segment basis and can be set for high deviation, low deviation, high and low deviation, or none.

The schedule may be changed (with some exceptions) from the current state to a new state by the operator as well as by inputs to the Scheduler function block in the controller configuration. Table 59 lists the resulting states.

Table 59 SPS inputs and current state

Input	Current State				
	READY	HOLD	RUN	GHOLD	STOP
RESET	READY	READY	RUN	READY	READY
HOLD	HOLD	HOLD	HOLD	HOLD	STOP
RUN	RUN	RUN	RUN	GHOLD	STOP
GHOLD	READY	HOLD	GHOLD	GHOLD	STOP

With regard to changing schedule state, if more than one function block input is on in the same execution cycle, RESET has priority over HOLD and RUN, and GHOLD has priority over RUN.

Also, function block inputs will override inputs from the Operator Panel which occur during the same execution cycle. Finally, state changes from the Operator Panel are processed on the basis of the “last change wins.”

Setpoint Scheduler Setup

Setpoint Scheduler setup is done through the SP Scheduler menu, accessed through the Main Menu.

Access

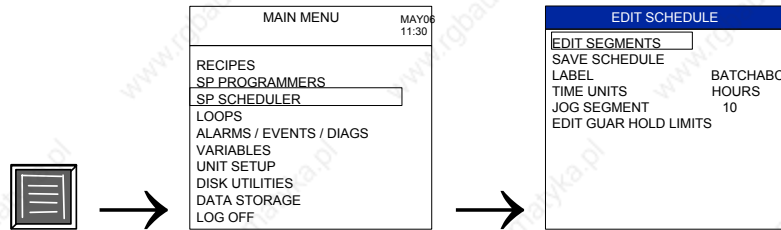

See also

While operating Setpoint Scheduler functions, messages may be displayed. See Table 119 for message descriptions.

What's in this section

Topic	See Page
Edit Schedule	115
Edit Segments	116
Edit Setpoints	117
Edit Segment Events	118
Edit Guarantee Hold	119
Save Schedule	120
Edit Guarantee Hold Limits	121

Edit schedule

This display lets you edit parameters of the selected schedule. Edits affect only the currently working schedule, not the schedule in memory, unless you save the schedule.



ATTENTION

Schedule must be in READY state to edit the values on this display.

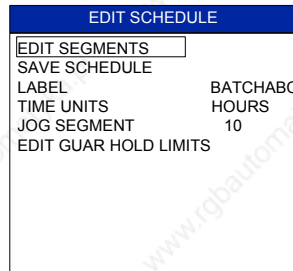

Figure 77 Edit schedule

Table 60 Edit schedule details

Feature	Description
EDIT SEGMENTS	Accesses Edit Segments menu (Figure 78) where you can edit each segment.
SAVE SCHEDULE	Saves changes you make to this display. Schedule is saved in the controller's schedule memory where it can be loaded and run later.
LABEL	Identifies the schedule with text.
TIME UNITS	This selection assigns the time units (hours or minutes) for the schedule.
JOG SEGMENT	Segment to which the schedule will jump to when the JOG discrete input is pulsed.
EDIT GUAR HOLD LIMITS	Accesses Edit Guarantee Hold Limits display (Figure 84) where you can edit guaranteed hold limits for each setpoint.

Edit segments

This menu lets you specify segment parameters. Edits do not affect schedules in memory unless you save them.



ATTENTION

Schedule must be in READY, HOLD, or STOP state before segments can be edited.

EDIT SCHEDULE SEGMENT	
F1 - NEXT SEG	F2 - PREV SEG
EDITING SCHEDULE #	3
SEGMENT #	10
CANNOT EDIT IN THIS STATE	
TIME	9999.999
RECYCLE COUNT	100
RECYCLE SEGMENT #	5
EDIT SETPOINTS	
EDIT EVENTS	
EDIT GUARANTEE HOLD	

Figure 78 Edit segment

Table 61 Edit segment details

Feature	Description
F1 - NEXT SEG	Select this to edit next segment.
F2 - PREV SEG	Select this to edit previous segment.
EDITING SCHEDULE #	Number of schedule being edited (1-10).
SEGMENT #	Segment being edited (1-50).
TIME	Range = 0.00 hr. to 9999.999 hr. or 0.00 min. to 9999.999 min.
RECYCLE COUNT	Number of recycles left
RECYCLE SEGMENT #	Recycle segment number
EDIT SETPOINTS	Select this to edit the segment setpoints. See <i>Edit setpoints (page 117)???</i>
EDIT EVENTS	Select this to edit the segment events. See <i>Edit segment events (page 118)</i> .
EDIT GUARANTEE HOLD	Select this to edit the segment's guarantee hold settings. See <i>Edit guarantee hold (page 119)</i> .



TIP

- Edits are allowed to any segment of the schedule, including the current segment.
- If edit is to current segment:
 - Changes to the setpoint will result in a step change.
 - Changes to the time will cause recalculation of the segment time remaining. If the result is less than or equal to 0, the schedule will advance to the next segment.
- If the starting value of the following segment is changed (F1-NEXT SEG), then the ramp rate in the current segment will be adjusted accordingly but the time remaining will remain unchanged.

Edit setpoints

This lets you edit the setpoints (8 main and 8 auxiliary) of any segment in the schedule.

EDIT SETPOINTS			EDIT SETPOINTS		
PAGE 1 OF 2		SEGMENT 50	PAGE 2 OF 2		SEGMENT 50
EDITS NOT ALLOWED IN THIS STATE			EDITS NOT ALLOWED IN THIS STATE		
SPLABEL1 SP1	123456.7	ENGU	AXLABEL1 AX1	123456.7	ENGU
SPLABEL2 SP2	123456.7	ENGU	AXLABEL2 AX2	123456.7	ENGU
SPLABEL3 SP3	123456.7	ENGU	AXLABEL3 AX3	123456.7	ENGU
SPLABEL4 SP4	123456.7	ENGU	AXLABEL4 AX4	123456.7	ENGU
SPLABEL5 SP5	123456.7	ENGU	AXLABEL5 AX5	123456.7	ENGU
SPLABEL6 SP6	123456.7	ENGU	AXLABEL6 AX6	123456.7	ENGU
SPLABEL7 SP7	123456.7	ENGU	AXLABEL7 AX7	123456.7	ENGU
SPLABEL8 SP8	123456.7	ENGU	AXLABEL8 AX8	123456.7	ENGU

Model 1041 has
16 Setpoints per page

Figure 79 Edit setpoints

Table 62 Edit setpoints details

Feature	Description
SPLABEL1 SP1 123456.7 ENGU . . . SPLABEL8 SP8 123456.7 ENGU	Listed are each setpoint's label, identifier, value, and engineering units. Select a setpoint value to change, then press Enter to save the change.
AXLABEL1 AX1 123456.7 ENGU . . . AXLABEL8 AX8 123456.7 ENGU	Press "Page Down" to list the auxiliary setpoints. Listed are each auxiliary setpoint's label, identifier, value, and engineering units. Select a setpoint value to change, then press Enter to save the change.

Edit segment events

This lets you edit the state of up to 16 events for the selected segment. You can configure 1 to 16 segment events to turn ON or OFF at the beginning of each segment. Segment events are digital switches that provide ON/OFF outputs. When a segment event is turned ON, it remains ON until the end of the segment at which time it is turned OFF unless it is configured to turn ON in the next segment.

EDIT SEGMENT EVENTS		
PAGE 1 OF 2		SEGMENT 50
EDITS NOT ALLOWED IN THIS STATE		
EVLABEL1	EV1	OFF
EVLABEL2	EV2	OFF
EVLABEL3	EV3	OFF
EVLABEL4	EV4	OFF
EVLABEL5	EV5	OFF
EVLABEL6	EV6	OFF
EVLABEL7	EV7	OFF
EVLABEL8	EV8	OFF
↓		
EVLABEL16	EV16	OFF

Model 1041 has
16 Events per page

Figure 80 Edit events

Table 63 Edit segment events details

Feature	Description
EVENT #1 – 16	ON or OFF



TIP

Events can be edited only while schedule is in READY state.

Edit guarantee hold

This lets you specify the conditions under which a segment will GHOLD when deviation exceeds the guarantee hold limits. If *any* setpoint's guarantee hold limit is exceeded, the entire schedule enters GHOLD state (all setpoints, auxiliary setpoints, and segment events freeze on their current value or state) until *none* of the limits are exceeded, whereupon the schedule will resume RUN state.

EDIT GUARANTEE HOLD SEGMENT 50	
EDITS NOT ALLOWED IN THIS STATE	
SPLABEL1 SP1	OFF
SPLABEL2 SP2	HI/LO
SPLABEL3 SP3	HIGH
SPLABEL4 SP4	LOW
SPLABEL5 SP5	LOW
SPLABEL6 SP6	LOW
SPLABEL7 SP7	LOW
SPLABEL8 SP8	LOW

Figure 81 Edit guarantee hold

Table 64 Edit guarantee hold details

Feature	Description
SPLABEL SP1	OFF: Segment will not GHOLD when the PV deviates from SP by its guarantee hold limit.
.	
.	HIGH: Segment will GHOLD if PV deviates above SP by more than the SP guarantee hold limit.
.	
SPLABEL SP8	LOW: Segment will GHOLD if PV deviates below SP by more than the SP guarantee hold limit.
	HI/LO: Segment will GHOLD if PV deviates above or below SP by more than the SP guarantee hold limit.

See also

See *Edit guarantee hold limits* (page 121).

Save schedule

This function saves a schedule to the controller’s schedule memory. It is accessed through the main menu or through the Scheduler Popup menu. The Scheduler can run any of the 10 schedules in controller memory. You can choose to save a schedule back to controller memory after editing it. See Figure 83.

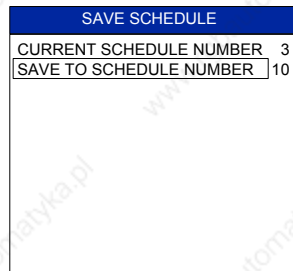

Figure 82 Save schedule

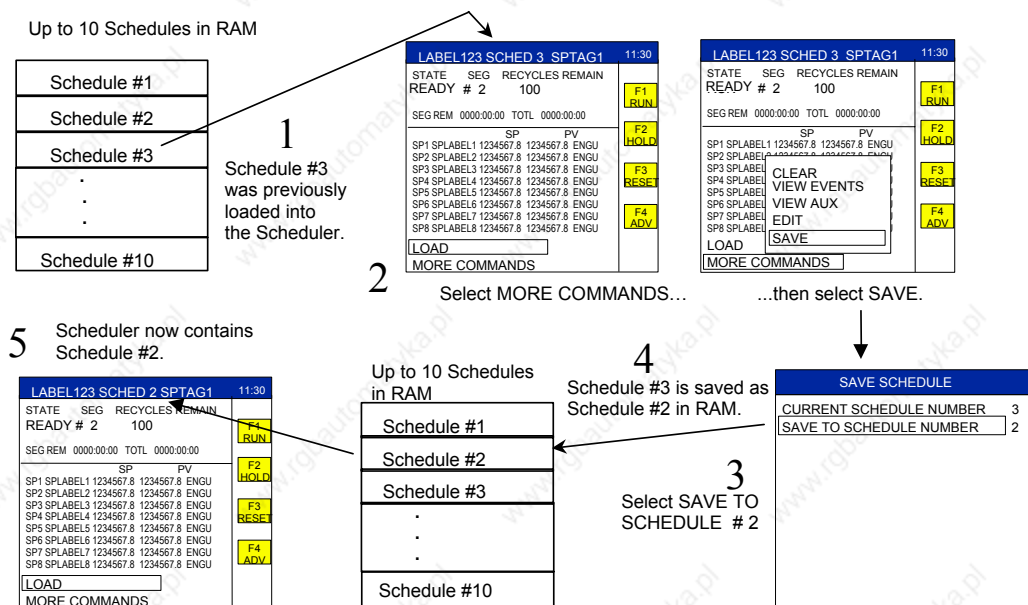

Figure 83 Example of saving a schedule

Table 65 Schedule save details

Feature	Description
CURRENT SCHEDULE NUMBER	Shows the schedule # currently loaded into the scheduler.
SAVE TO SCHEDULE NUMBER	There are 10 “slots” available in memory for schedules. ATTENTION: You will overwrite any schedule in the slot. Select the desired slot and press Enter to save the schedule. The schedule is also saved in the Scheduler.

Edit guarantee hold limits

This lets you specify the amount of deviation needed between a setpoint and its PV for the schedule to automatically switch to GHOLD state. If *any* setpoint's guarantee hold limit is exceeded, the entire schedule enters GHOLD state (all setpoints, auxiliary setpoints, and segment events freeze on their current value or state) until *none* of the limits are exceeded, whereupon the schedule will resume RUN state.

EDIT GUAR HOLD LIMITS		
EDITS NOT ALLOWED IN THIS STATE		
SPLABEL1 SP1	123456.7	ENGL
SPLABEL2 SP2	12345.67	ENGL
SPLABEL3 SP3	1234.567	ENGL
SPLABEL4 SP4	123.4567	ENGL
SPLABEL5 SP5	123.4567	ENGL
SPLABEL6 SP6	123.4567	ENGL
SPLABEL7 SP7	123.4567	ENGL
SPLABEL8 SP8	123.4567	ENGL

Figure 84 Edit guarantee hold limits

Table 66 Edit guarantee hold limits details

Feature	Description
SPLABEL1 SP1 . . . SPLABEL8 SP8	For each setpoint, enter the minimum amount of deviation between the Setpoint and PV that will GHOLD the schedule.

See also

See *Edit guarantee hold* (page 119).

Setpoint Schedule Operation

Overview

Setpoint schedule operation displays are accessed under the Display keys **1** through **5** (through 8 for Model 1041). A variety of setpoint schedule operation displays is available for your use to fit your application. Selection of display formats is performed using the Control Builder. All available displays are described in this section.

See also

While performing setpoint schedule operations, messages may be displayed. See Table 119 for message descriptions.

What's in this section

Topic	See Page
Setpoint Schedule Operation - Model 551/552	124
Setpoint Schedule Operation - Model 1041	126
Load Schedule	128
Scheduler Popup Menu - Model 551/552	130
View Scheduler Events	132
View Auxiliary Data	133
Edit Schedule Segments	134

Security

When Security is enabled, (See “Set Security”) the SPS operate display works as follows:

When the display is initially called, the security pop-up appears. Enter the proper security code then re-select the function. Access is permitted without further intrusion of the security pop-up until the display is removed from view.

Setpoint schedule operation - Model 551/552

This display shows live values of a setpoint scheduler.

LABEL123 SCHED 3 SPTAG1					11:30
STATE	SEG	RECYCLES	REMAIN		F1 RUN
RUN	# 2	100			
SEG REM	0000:00:00	TOTL	0000:00:00		F2 HOLD
	SP	PV			
SP1	SPLABEL1	1234567.8	1234567.8	ENGU	F3 RESET
SP2	SPLABEL2	1234567.8	1234567.8	ENGU	
SP3	SPLABEL3	1234567.8	1234567.8	ENGU	
SP4	SPLABEL4	1234567.8	1234567.8	ENGU	
SP5	SPLABEL5	1234567.8	1234567.8	ENGU	
SP6	SPLABEL6	1234567.8	1234567.8	ENGU	
SP7	SPLABEL7	1234567.8	1234567.8	ENGU	
SP8	SPLABEL8	1234567.8	1234567.8	ENGU	
LOAD					F4 ADV
MORE COMMANDS					

Figure 85 Setpoint schedule operation

Table 67 Setpoint schedule operation details

Feature	Description
LABEL123	Name of the selected schedule.
SCHED #	Schedule # is the memory location, 1 to 10, of this schedule.
SPTAG1	Tag
STATE	<p>READY: Schedule is at the beginning of segment and is ready to run. All events are OFF.</p> <p>HOLD: Schedule is paused at the setpoint value shown.</p> <p>RUN: Schedule is executing normally.</p> <p>GHOLD: Schedule is paused because of excessive deviation.</p> <p>STOP: Schedule has reached the end of the last segment.</p>
SEG #	Current segment
RECYCLES REMAIN	<p>Number of recycles remaining, according to the highest numbered segment so far encountered in the schedule.</p> <p><i>Example:</i></p> <p>Segment #30 has recycle count = 10 and recycle segment #5. Therefore, the first time the schedule reaches Segment #30, the schedule will recycle (repeat) Segments #5 through #30 ten times. During the first recycling, RECYCLES REMAIN will display "10", during the second recycling it will display "9", etc.</p>
SEG REM	Time remaining in the current segment.
TOTL	Total schedule time elapsed in RUN, HOLD, and GHOLD states.
SP	Each setpoint value in the current segment is shown under this heading.
PV	Each PV value is shown under this heading.

Feature	Description
LOAD	Accesses the Load Schedule display (Figure 87). Schedule must be in READY state.
MORE COMMANDS	Accesses the Popup Operate menu (Figure 90).
<div style="border: 1px solid black; background-color: yellow; padding: 2px; display: inline-block;"> F1 RUN </div>	Push F1 button to start a schedule that is in HOLD or READY state.
<div style="border: 1px solid black; background-color: yellow; padding: 2px; display: inline-block;"> F2 HOLD </div>	Push F2 button to put schedule in HOLD.
<div style="border: 1px solid black; background-color: yellow; padding: 2px; display: inline-block;"> F3 RESET </div>	Push F3 button to reset a HOLD, GHOLD, or STOP schedule to the first segment. Any edits made to the schedule are lost unless they were SAVED. See SAVE on the popup menu (Figure 90).
<div style="border: 1px solid black; background-color: yellow; padding: 2px; display: inline-block;"> F4 ADV </div>	Push F4 to cause the schedule to jump to the next segment. Schedules in the last segment will jump to the end of the schedule. Schedules cannot be advanced to the first segment.

Bold items are read-only.

Setpoint schedule operation - Model 1041

This display shows live values of a setpoint scheduler.





There are selections on the display that let you adjust and view parameters of the schedule.

SPTAG1		SCHED3		LABEL123		11:30	
STATE	SEG	RECYCLES REMAIN					
RUN	# 2	100					
SEG REM	0000:00:00	TOTL		0000:00:00		F1 RUN	
SP		PV					
SP1	SPLABEL1	1234567.8	1234567.8	ENGU	F2 HOLD		
SP2	SPLABEL2	1234567.8	1234567.8	ENGU			
SP3	SPLABEL3	1234567.8	1234567.8	ENGU	F3 RESET		
SP4	SPLABEL4	1234567.8	1234567.8	ENGU			
SP5	SPLABEL5	1234567.8	1234567.8	ENGU			
SP6	SPLABEL6	1234567.8	1234567.8	ENGU	F4 ADV		
SP7	SPLABEL7	1234567.8	1234567.8	ENGU			
SP8	SPLABEL8	1234567.8	1234567.8	ENGU			
LOAD							
CLEAR							
VIEW EVENTS							
VIEW AUX							
EDIT							
SAVE							

Figure 86 Setpoint schedule operation - Model 1041

Table 68 Setpoint schedule operation details - Model 1041

Feature	Description
SPTAG1	Tag
SCHED #	Schedule # is the memory location, 1 to 10, of this schedule.
LABEL123	Name of the selected schedule.
STATE	<p>READY: Schedule is at the beginning of segment and is ready to run. All events are OFF.</p> <p>HOLD: Schedule is paused at the setpoint value shown.</p> <p>RUN: Schedule is executing normally.</p> <p>GHOLD: Schedule is paused because of excessive deviation.</p> <p>STOP: Schedule has reached the end of the last segment.</p>
SEG #	Current segment
RECYCLES REMAIN	<p>Number of recycles remaining, according to the highest numbered segment so far encountered in the schedule.</p> <p><i>Example:</i></p> <p>Segment #30 has recycle count = 10 and recycle segment #5. Therefore, the first time the schedule reaches Segment #30, the schedule will recycle (repeat) Segments #5 through #30 ten times. During the first recycling, RECYCLES REMAIN will display "10", during the second recycling it will display "9", etc.</p>
SEG REM	Time remaining in the current segment.
TOTL	Total schedule time elapsed in RUN, HOLD, and GHOLD states.
SP	Each setpoint value in the current segment is shown under this heading.

Feature	Description
PV	Each PV value is shown under this heading.
LOAD	Accesses the Load Schedule display (Figure 87). Schedule must be in READY state.
CLEAR	Erases the schedule from the scheduler. Schedule must be in READY state. Do not clear a schedule if you need to save it first.
VIEW EVENTS	Displays the status of 16 events associated with this segment.
VIEW AUX	Displays the name and value of the 8 auxiliary setpoints and their PVs.
EDIT	Displays the Edit Segment menu (Figure 93). Schedule must be in READY, HOLD, or STOP state.
SAVE	Accesses the Save Schedule display (Figure 82). Schedule must be in READY, HOLD, or STOP state.
	Push F1 button to start a schedule that is in HOLD or READY state.
	Push F2 button to put schedule in HOLD.
	Push F3 button to reset a HOLD, GHOLD, or STOP schedule to the first segment. Any edits made to the schedule are lost unless they were SAVED. See SAVE on the display.
	Push F4 to cause the schedule to jump to the next segment. Schedules in the last segment will jump to the end of the schedule. Schedules cannot be advanced to the first segment.

Bold items are read-only.

Load schedule

This menu lets you load a schedule from memory into a setpoint scheduler where it can be run or edited.

LOAD SCHEDULE	
CURRENT SCHED NUMBER	3
	LABEL678
LOAD FROM SCHED NUM	10
LOAD FROM SCHED LIST	
SEGMENT NUMBER	5

Figure 87 Load schedule

Table 69 Schedule load details

Feature	Description
CURRENT SCHEDULE NUMBER	Number of schedule being run by the scheduler (1-10).
LOAD FROM SCHEDULE NUMBER	Number of schedule to be loaded from memory (1-10). Load schedule number 0 (zero) will clear the working schedule.
LOAD FROM SCHEDULE LIST	Schedule number selected from a list of schedules that appears will be loaded from memory.
SEGMENT NUMBER	After loading, the schedule will start at this segment. Subsequent runs will start at Segment #1. If the segment number is within a recycle loop, the schedule cycles through the recycled segments according to the number of recycles.

Bold items are read-only.

Load schedule from schedule number

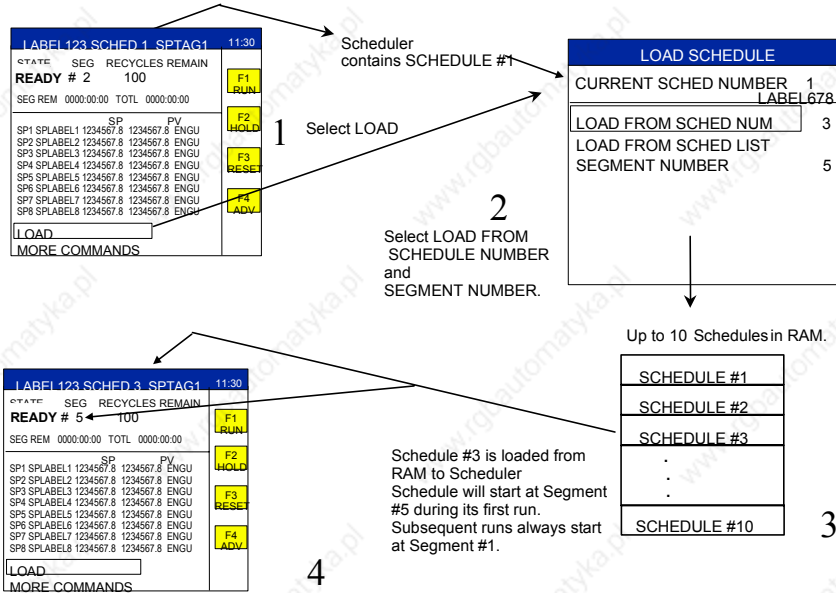

Figure 88 Example of loading a schedule from schedule number

Load schedule from schedule list

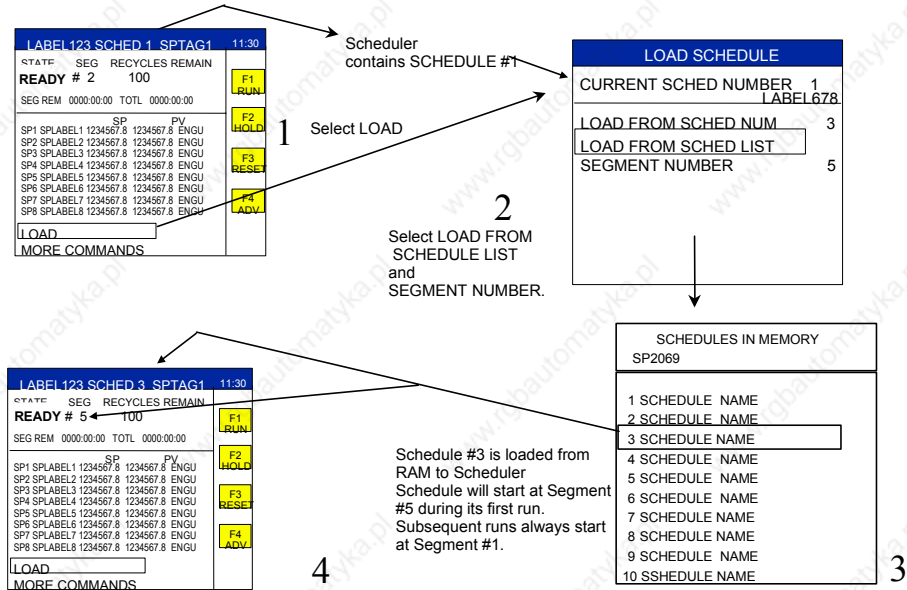

Figure 89 Example of loading a schedule from schedule list

Scheduler popup menu - Model 551/552

By choosing MORE COMMANDS, this menu lets you adjust and view parameters of the schedule. Some actions require the schedule to be in certain states (RUN, READY, etc.). See Table 70.

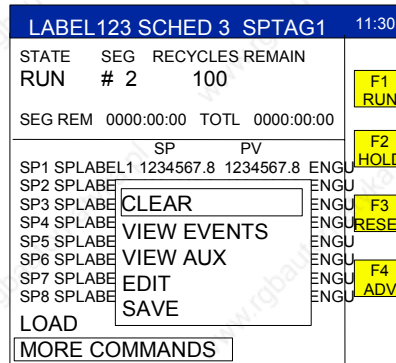

Figure 90 Scheduler operate popup menu

Table 70 Scheduler operate popup details

Feature	Description
CLEAR	Erases the schedule from the scheduler. Schedule must be in READY state. Do not clear a schedule if you need to save it first.
VIEW EVENTS	Displays the status of 16 events associated with this segment.
VIEW AUX	Displays the name and value of the 8 auxiliary setpoints and their PVs.
EDIT	Displays the Edit Segment menu (Figure 93). Schedule must be in READY, HOLD, or STOP state.
SAVE	Accesses the Save Schedule display (Figure 82). Schedule must be in READY, HOLD, or STOP state.
F1 RUN	Push F1 button to start a schedule that is in HOLD or READY state.
F2 HOLD	Push F2 button to put schedule in HOLD.
F3 RESET	Push F3 button to reset a HOLD, GHOLD, or STOP schedule to the first segment. Any edits made to the schedule are lost unless they were SAVED. See SAVE on the display.
F4 ADV	Push F4 to cause the schedule to jump to the next segment. Schedules in the last segment will jump to the end of the schedule. Schedules cannot be advanced to the first segment.

In the following table, X indicates the action can be performed when the schedule is in that state. NA means the action is not available in that state.

Table 71 SPS popup menu actions according to state

Action	Schedule state				
	READY	RUN	HOLD	GHOLD	STOP
CLEAR	X	NA	NA	NA	NA
EDIT	X	NA	X	NA	X
SAVE	X	NA	X	NA	X

View schedule events

This display lets you see the status of up to 16 events associated with each segment.

SPTAG1 SCHED10 LABEL123 11:30					
STATE	SEG	RECYCLES	REMAIN		
RUN	# 2	100			
SEG REM 0000:00:00 TOTL 0000:00:00					
EV1	EVENT111	OFF	EV9	EVENT999	OFF
EV2	EVENT222	OFF	EV10	EVENT123	OFF
EV3	EVENT333	OFF	EV11	EVENT456	OFF
EV4	EVENT444	OFF	EV12	EVENT789	OFF
EV5	EVENT555	OFF	EV13	EVENT234	OFF
EV6	EVENT666	OFF	EV14	EVENT567	OFF
EV7	EVENT777	OFF	EV15	EVENT890	OFF
EV8	EVENT888	OFF	EV16	EVENT345	OFF

Figure 91 View schedule events

Table 72 View schedule events details

Feature	Description
SPTAG1	Tag
SCHED #	Schedule # is the memory location, 1 to 10, of this schedule.
LABEL123	Name of the selected schedule.
STATE	Current state of program.
SEG #	Current segment (1-50).
RECYCLES REMAIN	Number of recycles remaining, according to the highest numbered segment so far encountered in the schedule. <i>Example</i> Segment #30 has recycle count = 10 and recycle segment #5. Therefore, the first time the schedule reaches Segment #30, the schedule will recycle (repeat) Segments #5 through #30 ten times. During the first recycling, RECYCLES REMAIN will display "10", during the second recycling it will display "9", etc.
SEG REM	Time remaining in the current segment.
TOTL	Total schedule time elapsed in RUN, HOLD, and GHOLD states.
EV# EVENTxxx	State of 16 events associated with this segment. ON or OFF.

Bold items are read-only.

View auxiliary data

This display lets you see details on the schedule auxiliary setpoints and PVs.

SPTAG1 SCHED10 LABEL123 11:30			
STATE	SEG	RECYCLES	REMAIN
RUN	# 2	100	
SEG REM 0000:00:00			TOTL 0000:00:00
SP		PV	
AX1 AXLABEL1	1234567.8	1234567.8	ENGU
AX2 AXLABEL2	1234567.8	1234567.8	ENGU
AX3 AXLABEL3	1234567.8	1234567.8	ENGU
AX4 AXLABEL4	1234567.8	1234567.8	ENGU
AX5 AXLABEL5	1234567.8	1234567.8	ENGU
AX6 AXLABEL6	1234567.8	1234567.8	ENGU
AX7 AXLABEL7	1234567.8	1234567.8	ENGU
AX8 AXLABEL8	1234567.8	1234567.8	ENGU

Figure 92 View auxiliary data

Table 73 View auxiliary data details

Feature	Description
SPTAG1	Tag
SCHED #	Schedule # is the memory location, 1 to 10, of this schedule.
LABEL123	Name of the selected schedule.
STATE	Current state of program.
SEG #	Current segment (1-50).
RECYCLES REMAIN	<p>Number of recycles remaining, according to the highest numbered segment so far encountered in the schedule.</p> <p><i>Example</i></p> <p>Segment #30 has recycle count = 10 and recycle segment #5. Therefore, the first time the schedule reaches Segment #30, the schedule will recycle (repeat) Segments #5 through #30 ten times. During the first recycling, RECYCLES REMAIN will display "10", during the second recycling it will display "9", etc.</p>
SEG REM	Time remaining in the current segment.
TOTL	Total schedule time elapsed in RUN, HOLD, and GHOLD states.
AX# AXLABEL	Labels of the 8 auxiliary setpoints
SP	Under the SP heading are listed the values of the 8 auxiliary setpoints.
PV	Under the PV heading are listed the values of the 8 auxiliary PVs.

Bold items are read-only.

Edit segments

This menu lets you edit the schedule segments of the working schedule. Edits do not affect schedules in memory unless you save them.



ATTENTION

Schedule must be in READY, HOLD, or STOP state before segments can be edited.

SPS SCHEDULE EDIT SEGMENT	
F1 - NEXT SEG	F2 - PREV SEG
EDITING SCHEDULE #	3LABEL
SEGMENT #	10
TIME UNIT	HOURS
TIME	<input type="text" value="0.000"/>
EDIT SETPOINTS	

Figure 93 Edit segments

Table 74 Edit segments details

Feature	Description
F1 - NEXT SEG	Select this to edit next segment.
F2 - PREV SEG	Select this to edit previous segment.
EDITING SCHEDULE # LABEL	Number and label of schedule being edited (1-10).
SEGMENT #	Segment being edited (1-50).
TIME UNITS	Time units of the schedule. Minutes or Hours.
TIME	Range = 0.00 hr. to 9999.999 hr. or 0.00 min. to 9999.999 min.
EDIT SETPOINTS	Lets you edit the segment setpoints (Figure 79).

Bold items are read-only.

Alarms

Overview

Alarms defined

An alarm is an indication of a discrete status which warrants operator attention. For example, suppose a relay switches on to close a valve if a thermocouple detects a high temperature. An alarm can be configured to be triggered by the relay switching on.

Any discrete status may be configured as an alarm by simply assigning it to one of the Alarm Group displays using the LeaderLine Control Builder. By doing so, the Controller will automatically monitor the discrete status as an alarm, and the Operator Interface will present the discrete status as an alarm. Discretes that are not assigned to an Alarm Group are not alarmed.

Note that the control function blocks in the LeaderLine Control Builder (PID, CARBON, ON/OFF, 3 POS, A/M BIAS) contain 2 discrete points, AL1 and AL2. These “alarms” switch on when, for example, the loop’s PV exceeds a specified value. These discrete points AL1 and AL2 must be assigned to an Alarm Group to be indicated as alarms.

The main idea to remember is that a discrete point is considered an alarmed point only if it has been assigned to an Alarm Group display.

There are three classes of alarm types.

- Discrete alarm
- Analog alarm (latched and unlatched)
- Loop alarm

These alarm types are explained next.

Discrete alarm types

A discrete alarm is any discrete point that has been assigned to an Alarm Group. It can be a tagged discrete signal from any function block. These are unlatched alarms.

Analog alarm types

The Analog Alarm function block will output a discrete signal that is triggered by the following conditions within the Analog Alarm function block. For this discrete signal to be visible as an alarm, it must be assigned to an Alarm Group display.

- $PV > CV$: Process variable > compare value
- $PV < SP$: Process variable < alarm setpoint
- $PV < CV$: Process variable < compare point
- $PV > SP$: Process variable > alarm setpoint
- $(PV - CV) > SP$: Deviation > alarm setpoint (high deviation)
- $(PV - CV) < SP$: Deviation < alarm setpoint (low deviation)
- $|PV - CV| > SP$: Absolute value of deviation > alarm setpoint (band deviation)

Analog alarm latching

In LeaderLine Control Builder, analog alarms can be configured as latched or unlatched. An unlatched alarm returns to normal (not in alarm) as soon as the alarm conditions clear. A latched alarm “freezes” in the on state, even after the alarm conditions no longer exist. A latched alarm returns to normal (not in alarm) only if:

1. The alarm conditions clear, AND
2. The operator acknowledges the alarm’s occurrence.

Latched alarms notify you that an alarm occurred and they force the operator to acknowledge them before a return to normal condition may be indicated.

Loop alarm types

Control loop function blocks—PID, ON-OFF, 3POS, A/M BIAS, and CARBON—contain output pins (AL1 and AL2) that are each triggered by the following conditions within the loop. For either of these output pins to be visible as an alarm, it must be assigned to an Alarm Group display. These are unlatched alarms.

- PV High – Alarm when PV is greater than the alarm setpoint
- PV Low – Alarm when PV is less than the alarm setpoint
- SP High – Alarm when SP is greater than the alarm setpoint
- SP Low – Alarm when SP is less than the alarm setpoint
- Out High – Alarm when output is greater than the alarm setpoint
- Out Low – Alarm when output is less than the alarm setpoint
- Dev High – Alarm when deviation (PV – SP) is greater than the alarm setpoint.
- Dev Low – Alarm when deviation (SP – PV) is greater than the alarm setpoint.

Alarm indication

Alarms are indicated using a 4-level hierarchy.

- Red alarm indicator at the bottom of the display. This indicator appears on all displays and alerts the operator to the presence of an alarm in the system. The red indicator flashes when any alarm exists that has not been acknowledged; the indicator is solid (not flashing) when all alarms have been acknowledged but their conditions still exist.
- Alarm Summary display. Provides a quick overview as to the location of alarms in the system.
- Alarm Group display. This display indicates the specific alarm(s) in an alarm group.
- Alarm Detail display. This display provides specific information on a single alarm.

Investigating alarms

Three methods are available to access the Alarm displays. The first two methods are standard. The third method is configurable.

1. Press Alarm from any display (except alarm group) to see the Alarm Summary. Select the desired group and press Enter to see the Alarm Group.

2. Press Menu to access the Main Menu, then select Alarms/Events/Diagnostics. Select Alarm Summary. Select the desired group and press Enter to see the Alarm Group.
3. Configure the Display keys to contain Alarm Group displays as appropriate for your application. Press the Display key and use Page Up and Page Down to see the Alarm Groups.

Alarm Summary

The Alarm Summary gives you the composite status of each alarm group.

Access

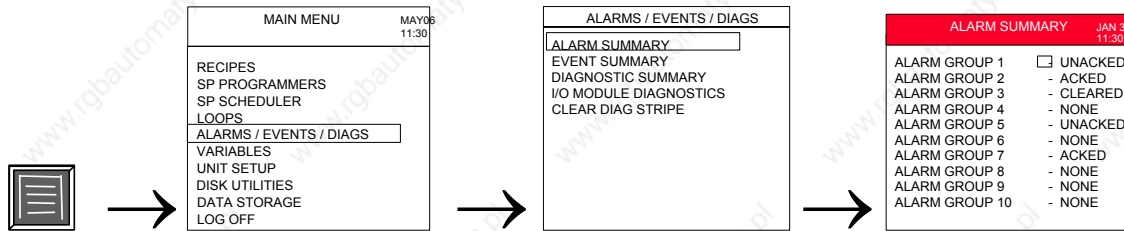

OR

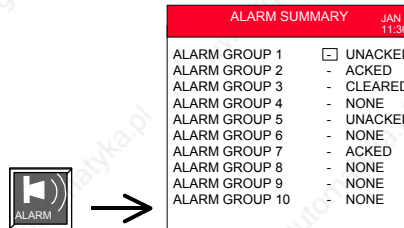

Description

ALARM SUMMARY		JAN 31 11:30
ALARM GROUP 1	<input type="checkbox"/> UNACKED	
ALARM GROUP 2	- ACKED	
ALARM GROUP 3	- CLEARED	
ALARM GROUP 4	- NONE	
ALARM GROUP 5	- UNACKED	
ALARM GROUP 6	- NONE	
ALARM GROUP 7	- ACKED	
ALARM GROUP 8	- NONE	
ALARM GROUP 9	- NONE	
ALARM GROUP 10	- NONE	

Figure 94 Alarm summary

Table 75 Details of alarm summary

Feature	Description
Number of alarm groups	Up to 10 alarm groups. Each group has up to 12 alarms.
Attributes shown	Ten alarm groups and their statuses.
Alarm Group Status	<p>UNACKED: At least one point in the alarm group is in alarm and has not been acknowledged by the operator. Press Enter to see all points in the group.</p> <p>ACKED: No points in the alarm group are unacknowledged. At least one point in the alarm group is in alarm and has been acknowledged by the operator. Press Enter to see all points in the group.</p> <p>CLEARED: At least one point in the alarm group was in alarm then out of alarm and was not acknowledged.</p> <p>NONE: No points in the alarm group are in alarm.</p>

Alarm Group

This display shows the status of each discrete point in the selected alarm group.

Access

ALARM SUMMARY		JAN 3 11:30
ALARM GROUP 1	<input type="checkbox"/> UNACKED	
ALARM GROUP 2	- ACKED	
ALARM GROUP 3	- CLEARED	
ALARM GROUP 4	- NONE	
ALARM GROUP 5	- UNACKED	
ALARM GROUP 6	- NONE	
ALARM GROUP 7	- ACKED	
ALARM GROUP 8	- NONE	
ALARM GROUP 9	- NONE	
ALARM GROUP 10	- NONE	

→

ALARM GROUP 1			11:30
TAG5678 STATE1	TAG5678 STATE2	TAG5678 STATE1	C
TAG5678 STATE2	TAG5678 STATE1	TAG5678 STATE1	
TAG5678 STATE1	TAG5678 STATE1	TAG5678 STATE1	
TAG5678 STATE1	TAG5678 STATE1	TAG5678 STATE1	

OR

Press the Display key (1-5[D8 for 1041]) under which the Alarm Group is assigned.

Description

ALARM GROUP 1			11:30
TAG5678 STATE1	TAG5678 STATE2	TAG5678 STATE1	C
TAG5678 STATE2	TAG5678 STATE1	TAG5678 STATE1	
TAG5678 STATE1	TAG5678 STATE1	TAG5678 STATE1	
TAG5678 STATE1	TAG5678 STATE1	TAG5678 STATE1	

Figure 95 Alarm group display

For each alarm point the following is displayed.

- Tag name
- Current state of the point (ON/OFF, OPEN/CLOSED, etc.)
- Alarm state. Possible states are
 - Flashing LED – in alarm and unacknowledged
 - Solid LED – in alarm and acknowledged.
 - C – The point went in alarm then out of alarm and was not acknowledged.
 - Blank – Not in alarm

Acknowledging alarms

To acknowledge all alarms in the group, press Alarm. If an alarmed point appears in multiple alarm groups, you must acknowledge each group containing that point.

Alarm Detail

This display shows the following details about the selected alarm point in a group:

- Tag name and description
- Last time the selected point was in alarm (off-to-on)
- Last time the selected point went out of alarm (on-to-off)
- Two lines of help text
- If the selected point has not been in alarm since the Controller was reset, the following message is displayed: NO ALARM SINCE LAST RESET.

Access

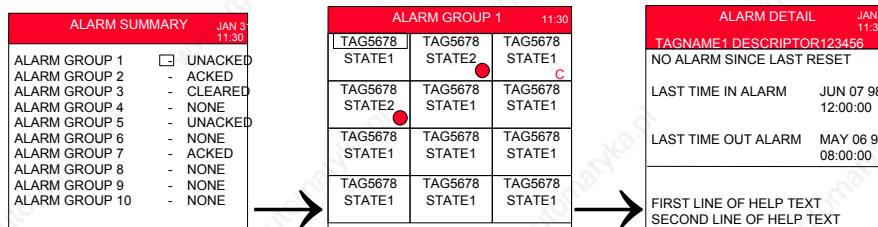

Description

With Alarm Group displayed, press Tab and Detail keys to move the cursor to the desired alarm tag. Press Enter to show that alarm's details. Press Escape to return to the Alarm Group display.



TIP



This display does not update periodically, that is, changes to the alarm status while you are looking at this display are not shown.

Other Operating Displays

Overview

The following operating displays are also configured using the Control Builder.

- Pushbutton Displays
- 4-Selector Switch Display
- Recipe Load Display
- Device Control Display
- Hand/Off/Auto Switch Display

They are accessed by pressing  through  (through 8 for Model 1041) below the display. Use **Page Up** and **Page Down** to scroll through up to ten displays assigned to each Display Group key. **Your Operator Interface may not necessarily have all these displays configured.**

Pushbuttons

Up to four pushbutton displays are available, with four functions on each display. To perform the function description, press the corresponding F1-F4 key located immediately to the right of the display. For example, press F1 to perform the topmost function.

Description

- Accessed through any Display key (as configured).
- Use F1 – F4 keys to issue discrete control.
- Shows feedback of an associated discrete state or an analog value.
- Shows text description of the action performed.





PUSHBUTTON GROUP		
TAG45678 STATE1	FUNCTION DESCRIP	
TAG45678 STATE1	FUNCTION DESCRIP	
TAG45678 STATE1	FUNCTION DESCRIP	
TAG45678 STATE1	FUNCTION DESCRIP	

Figure 96 Pushbutton menu with function keys

Table 76 Pushbutton details

Feature	Description
Tag	Name of the discrete or analog signal.
State/Value	State of the signal (ON/OFF, OPEN/CLOSED, etc.) or current value.
Function	Description of the function. To perform the function, press the corresponding F1-F4 key located immediately to the right of the display.

4-Selector Switch

This display has four functions accessible by the four function keys to the right of the display. Once a function is selected, you can select one of four possible states for that function. That is, the function acts as a 4-position rotary switch, with one and only one state in effect at any time.

DIGITAL GROUP TITLE	
FUNCTION DESCRP1	STATE1 F1
FUNCTION DESCRP2	STATE2 F2
FUNCTION DESCRP3	STATE3 F3
FUNCTION DESCRP4	STATE4 F4

Figure 97 Four selector switch display

Table 77 Four selector switch details

Feature	Description
FUNCTION DESCRP1	Name of the function accessed by F1 key.
STATE1	Current state of F1 function.
FUNCTION DESCRP2	Name of the function accessed by F2 key.
STATE2	Current state of F2 function.
FUNCTION DESCRP3	Name of the function accessed by F3 key.
STATE3	Current state of F3 function.
FUNCTION DESCRP4	Name of the function accessed by F4 key.
STATE4	Current state of F4 function.

To select a function, press the key corresponding to that function. A popup menu appears. See Figure 98. This popup menu shows the four selectable states for the function you chose. Only one state at a time is allowed.

DIGITAL GROUP TITLE	
FUNCTION DESCRIP	STATE3 F1
FUNCTION DESCR	STATE1 F2
FUNCTION	STATE2 F3
FUNCTION	STATE4 F4

USE ARROW KEYS TO SELECT
PRESS ENTER TO INITIATE
PRESS ESC TO ABORT

Figure 98 Four selector switch popup menu

Device Control

This display has four device controls accessible by the four function keys to the right of the display. There are four device controls per display, for a total of four displays. The order of the device controls can be changed by way of the “Control Builder”.

This display can be assigned to one of the D1-D5[D8 for 1041] keys during configuration.

When you select one of the F# keys on the display, the EDIT DEVICE display is opened.

DEVICE CONTROL			
DEVTAG1	READY	99999 SECS	F1
DEVTAG2	DISABLED	99999 SECS	F2
DEVTAG3	RUNNING	99999 SECS	F3
DEVTAG4	READY	99999 SECS	F4

Figure 99 Device control display

Table 78 Device control display details

Feature	Description
DEVTAG#	Block tag name defined during block configuration.
STATE	READY, PRESTART, STARTING, RUNNING, STOPPING, DISABLED, or FAIL.
99999 SECS	<p>Current Timer value. READ ONLY – Counts down to zero.</p> <ul style="list-style-type: none"> The Start Delay Timer is active in the Prestart state The Stop Delay Timer is active in the stopping state The Feedback timer is active in the Starting state while the Feedback input pin is OFF. The Feedback timer is active in the Running state (if the Feedback input turned on in the starting state.)

Press F# key on the display to edit DEVICE CONTROL display.

Change the current delay times

When you press the F# key on the display, the EDIT DEVICE display is opened. You can change the current delay times for START, STOP, and FEEDBACK FAIL Timers.

EDIT DEVICE	
DEVTAG1	FAILURE
START DELAY TIME (SEC)	99999
STOP DELAY TIME (SEC)	99999
FEEDBACK FAIL TIME (SEC)	99999
RESET FAILURE	

Figure 100 Edit device display

Table 79 Edit device display details

Feature	Description
DEVTAG1	Tag name defined during block configuration – READ ONLY.
FAILURE	Current state of device – Located in the lower right corner of the title area of the display.
START DELAY TIME	0-99999 seconds – Current start delay time
STOP DELAY TIME	0-99999 seconds – Current stop delay time
FEEDBACK FAIL TIME	0-99999 seconds – Current feedback fail delay time
RESET FAILURE	The device may only be reset if it is currently in the failure state, the ERR (failure) input pin on the function block is OFF, and the Automatic Reset parameter (configured on the control builder) is OFF. Otherwise a warning dialog is displayed explaining the reason why the Device Reset Request failed. Reasons for ignoring reset request: <ul style="list-style-type: none"> a. Failure Input pin is ON. b. Automatic Reset is enabled. c. Device is not in Failure state.



TIP

If you select the ESC key, the Operator Interface will return to the Device Control Operator display.

Hand/Off/Auto Switch

This display has four HOA switches accessible by the four function keys to the right of the display. The order of the HOA switches can be changed using the Control Builder.

This display can be assigned to one of the D1-D5 [D8 for 1041] keys during configuration.

When you select one of the F# keys on the display, the SET HAND/OFF/AUTO SWITCH display is opened.

HAND/OFF/AUTO SWITCH		
SIGTAG_A STATE1	HOATAG1 AUTO	F1
SIGTAG_B STATE8	HOATAG2 AUTO	F2
SIGTAG_C STATE2	HOATAG3 HAND	F3
SIGTAG_D STATE7	HOATAG4 OFF	F4

Figure 101 Hand/Off/Auto switch display

Table 80 Hand/Off/Auto switch display details

Feature	Description
SIGTAG_A, B, C, or D	Eight-character tag name of the feedback signal providing the analog value for the State enumeration.
STATE# [8]	Eight-character State enumeration – defined during block configuration.
HOATAG#	Block tag name defined during block configuration – READ ONLY.
STATE OF SWITCH	HAND, OFF, AUTO, or BYPASS

Press F# key on the display to set the State for each HOA switch.

Set the HOA switch state

When you press an F# key on the display, the SET HAND/OFF/AUTO SWITCH display is opened.

SET HAND/OFF/AUTO SWITCH	
HOATAG1	
CURRENT STATE	HAND
CHANGE SOURCE	LOCAL
SET STATE:	OFF AUTO HAND

Figure 102 Set HOA switch state display

Table 81 Set HOA switch state display details

Feature	Description
HOATAG#	Block tag name defined during block configuration.
CURRENT STATE	HAND, OFF, AUTO, or BYPASS (note 1)
CHANGE SOURCE	LOCAL, REMOTE, LOCAL/REMOTE
SET STATE	Select OFF, AUTO, or HAND (note 1)

Note 1: If the current state is BYPASS, any requests to change the state are ignored.



TIP

- If you select the ESC key, the Operator Interface will return to the HOA Switch Operator display.
 - The CHANGE SOURCE setting shall supply support for secure entry.
-

Recipe Load

This display lets you load a recipe into the controller configuration. A recipe is a collection of up to 50 variables.

Scroll down to the desired recipe and press Enter. A popup menu appears. Select Load to initiate the load, or select Cancel to return to the previous display. A message confirms that the load is completed.

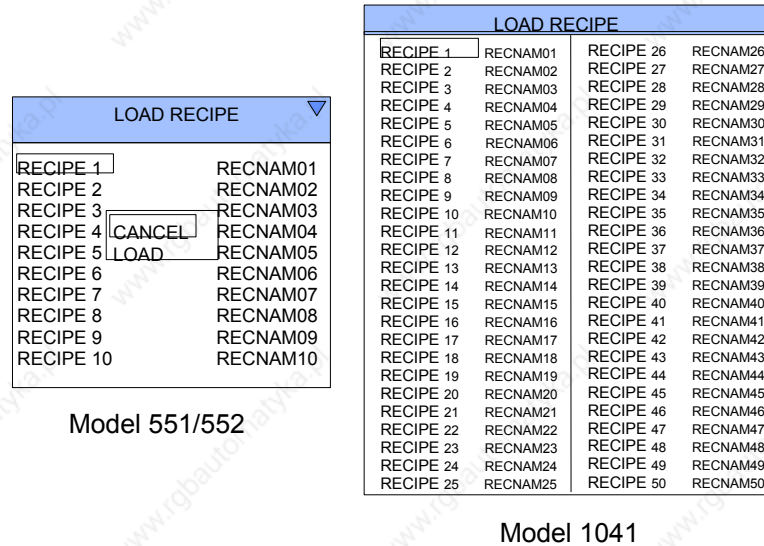

Figure 103 Recipe load



TIP

When you load a recipe, you are in effect writing new values to those variables in the configuration. Be aware that the controller configuration may contain a Recipe Load function block that, without your knowledge, can load a second recipe after you loaded one here. If this second recipe is loaded, the values you just loaded may be overwritten by different values. That means that some or all of the recipe values or states you intended to load are not in effect.

To check that your recipe load took effect, after loading a recipe you can view the variables to see they are set to the desired recipe values or states. See *Variables* (page 51).

If a recipe's variables do not seem to be loading properly, consider reconfiguring the controller to eliminate the Recipe Load function block that is causing the conflict.

Monitoring Displays

Overview

Monitoring displays are configured using the Control Builder. They are accessed by pressing **1** through **5** (through 8 for Model 1041) below the display. Use **Page Up** and **Page Down** to scroll through up to ten displays assigned to each Display Group key. **Your Operator Interface may not necessarily have all these displays configured.**

You can monitor but not change any data on these displays except for overview variables.

See also

While viewing these displays, messages may be displayed. See Table 119 for message descriptions.

What's in this section

Topic	Page
Trend Displays: Horizontal Trend Vertical Trend Vertical Trend w/ Horizontal Bars Horizontal Trend w/ Digital Horizontal Trend w/ Bar Graphs	150
Bar Graph Displays: 6 Point Horizontal 6 Point Vertical 3 Point Horizontal 3 Point Vertical	154
Panel Displays: Single Point Panel 4-Point Panel Multi Point Panel Overview	155
Other Displays: Help	159

Trend Displays

Each of the five types of trend displays shows up to 6 points as trends. The text changes at regular intervals to describe the name, current value, limits, and engineering units of the corresponding trend. The color of the text matches the color of the trend: red text describes the red trend, green text describes the green trend, and so on for each of the six trends.

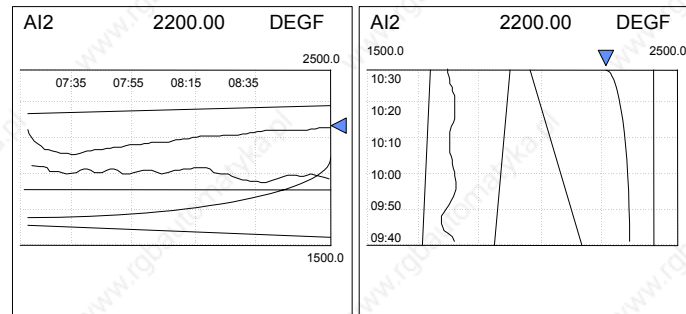

Horizontal Trend

Vertical Trend

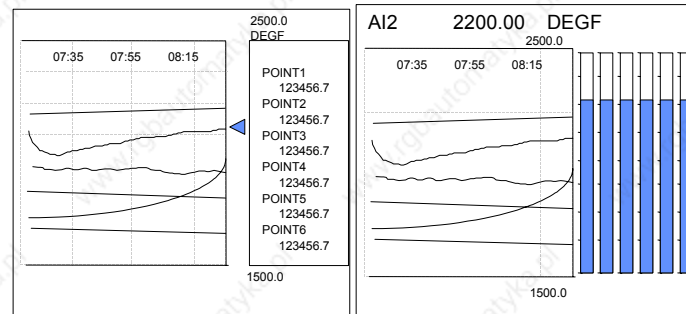

Horizontal Trend with Digital

Horizontal Trend with Bar Graph

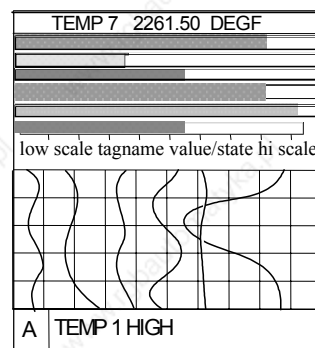

Vertical Trend with Horizontal bars

Figure 104 Trend displays

Log Scale Trending

The Control Builder lets you select 127 as a decimal place for a signal tag with E-notation. When you select a signal tag with E-notation as the first signal tag when configuring a Trend group, the Operator Interface will display the Trend in Log Scaling.

Table 82 Example of trend details

Feature	Description
AI2	Name of one of 6 points displayed.
2200.00	The current value of the point.
DEGF	Engineering units of the point.
1500.0	Lower display limit of the point.
2500.0	Upper display limit of the point.
09:40, 09:50, etc.	Time stamps.
Colored Arrow	Positioned at the current value of the point.
Vertical and Horizontal Bar Graphs*	Since the number of bars on the display varies for both type of O/I (551/552 vs. 1041) and the Trend display format, note that for any given format, the bars represent the first "n" point of the Trend. "n" may be 3, 4, or 6. Also note that the color of the bar will match the color of the trend line, pointer, and live value.
POINT1...POINT6**	Shows the value of each trend in matching color.

* Horizontal or Vertical Trend with Bar Graph only

** Horizontal Trend with Digital only



TIP

Press Detail to display a menu with advanced features. See *Trend menu*.

Trend menu

From any trend display, press Detail to display the following menu.

Table 83 Trend menu

Prompt	Description
SCROLL	<p>Press Increment or Decrement to scroll the trend forward or backward in time. Press Detail to change to the next point on a multi-point trend. Amount of scrollable data is inversely proportional to the number of trend groups and points; that is, the more trend points that are configured, the less data that can be scrolled to.</p> <p>Press Escape to restore the Trend menu. The trend display will remain at the time determined by the SCROLL.</p> <p>Press Escape to restore the original trend display and cancel the SCROLL.</p>
SET HOLD, REL HOLD	<p>Causes one point to remain displayed in the scoreboard. Available for live trend only.</p> <p>Before selecting SET HOLD, press Detail to change the scoreboard to the desired point. Select SET HOLD and press Enter. An "H" appears in the lower right display. The HOLD will remain in effect until deliberately removed with REL HOLD.</p> <p>To HOLD a different point, press Detail until the desired point is shown, then press Escape.</p> <p>To release the HOLD, select REL HOLD.</p>
DETAIL	<p>Use the Increment and Decrement keys to move the line cursor forward or backward in time. The value of the displayed point will change to its value at the new time.</p> <p>If desired, press Detail to change to the next point on a multi-point trend.</p> <p>Press Escape to restore the menu. The trend display will remain at the chosen point.</p> <p>Press Escape to restore the trend display and to cancel DETAIL.</p>
ZOOM	<p>Lets you magnify (zoom) the displayed scale.</p> <p>Press Increment and Decrement to select the amount of magnification, shown in the lower right corner of the display. Note that the size of the Zoom cursor changes accordingly. See Figure 105.</p> <p>OFF – uses point's programmed limits (turns Zoom off)</p> <p>2X – uses half of point's programmed limits</p> <p>4X – uses one fourth of point's programmed limits.</p> <p>For example, assume the currently selected point has limits of 0 and 1000 degrees F and its current value is 500. If you select a zoom of 2X, the point will be displayed with limits of 250 and 750 degrees F.</p> <p>Note that zooming in on a screen with a wide time span may cause the trend to appear jagged due to the slow sampling rate for wide screens. See Table 84</p> <p>Press Detail to select the point/trace to be zoomed (magnified).</p> <p>Press Enter to display the magnified trend. The popup menu is displayed to allow further analysis.</p> <p>Press Escape to restore the trend display with the ZOOM limits. A "Z" appears in the lower right of the display.</p>

Alternate method of scrolling

A trend can be also be scrolled by pressing Increment and Decrement without pressing Detail. While in scroll mode, press Escape once to see the trend menu, or press Escape twice to return the live screen.

Sampling rates of trends

The longer the time span of a trend display, the less often the points are sampled.

Table 84 Sampling rates of trends

Time span of screen	Rate at which points are sampled
30 minutes	6 seconds
1 hour	12 seconds
2 hours	24 seconds
4 hours	48 seconds
8 hours	96 seconds
24 hours	288 seconds

Example of trend zoom

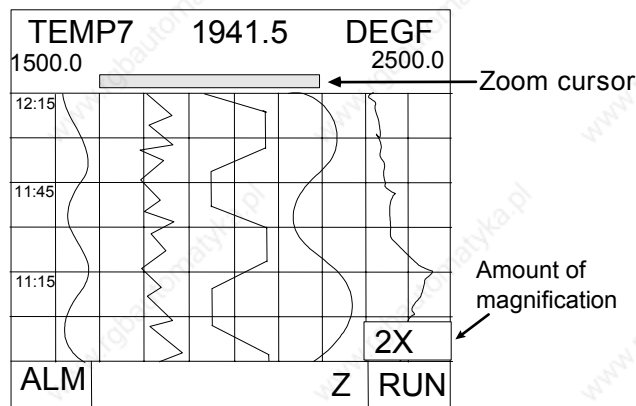
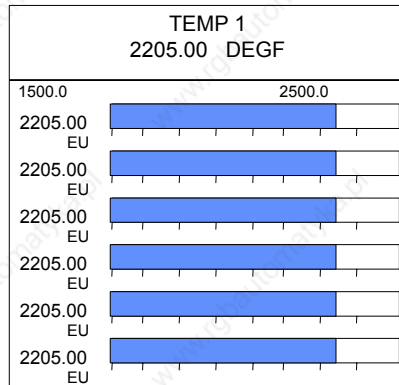

Figure 105 Vertical trend at 2X zoom

Bar Graph Displays

These displays show 3 or 6 points in a vertical or horizontal bar graph format. The 6 bar displays periodically rotate through the name and value of each point.



6 Point Horizontal Bar

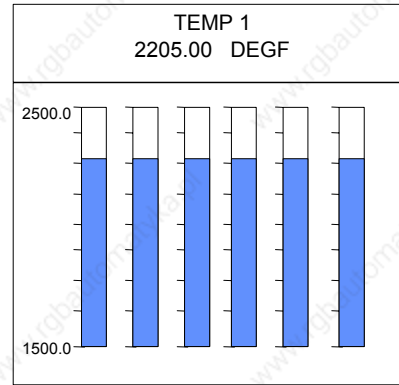

6 Point Vertical Bar

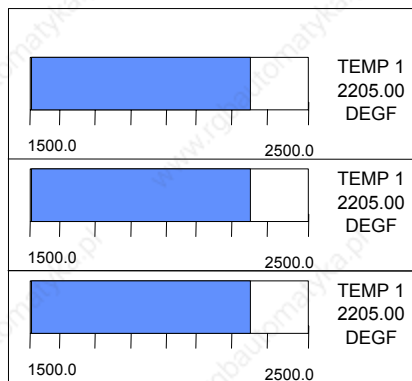

3 Point Horizontal Bar

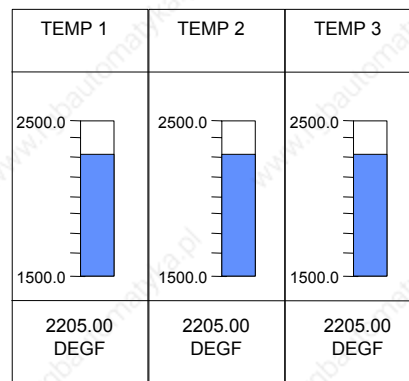

3 Point Vertical Bar

Figure 106 Bar graph displays

Table 85 Bar graph display details

Feature	Description
TEMP n	Name of the displayed point.
2205.00	The current value of the point.
DEGF	Engineering units of the point.
1500.0	Lower display limit of the point.
2500.0	Upper display limit of the point.

Panel Displays

Single point panel

This display is readable from a distance of approximately 15' (4 meters). It periodically rotates through up to 12 points, one at a time.



Figure 107 Panel display

Interacting with panel display

Stopping panel display rotation on a single point

Step	Action	Result
1	Press Detail	Displays menu item SET HOLD at the lower right hand corner of the display.
2	Press Detail	Displays the desired point.
3	Press Enter	Holds display on desired point. An "H" appears in the lower right of the display.

Resuming panel display rotation through all points

Step	Action	Result
1	Press Detail	Displays menu item REL HOLD at the lower right hand corner of the display.
2	Press Enter	The "H" disappears and rotation resumes.

4-point panel

This display show the status and values for four analog and digital points in a panel format. The display is view only. A digital point's ON state is indicated On by a yellow dot. No dot indicates OFF state.

4-POINT PANEL TITLE	
INTRUSN ON 	ZONE 1 205.00 DEGF
TEMP 2 134.4 DEGC	ZONE 2 456.2 DEGF

Figure 108 4-point panel display

Table 86 4-point panel details

Feature	Description
TAGNAME _n	Name of the displayed point.
Value or State	The current value or state of the point.
EU	Engineering units of the point.

Mutli-point panel

This display contains 3 large points for easier reading at a distance, and 4 normal sized points for close-up viewing. The display is VIEW only.

PANEL GROUP 1		
TAGNAME1	2205.0	DEGF
TAGNAME2	2000.0	DEGF
TAGNAME3	ON	
TAGNAME4	205.0	DEGF
TAGNAME5	OFF	
TAGNAME6	83.5	DEGF
TAGNAME7	ON	

Figure 109 Multi-point panel display

Table 87 Multi-point panel details

Feature	Description
TAGNAME _n	Name of the displayed point.
Value or State	The current value or state of the point.
EU	Engineering units of the point.

Panel meter

Displays status and value of twelve analog and digital points in a panel format. This display is view-only.

A digital point's ON state is indicated ON by a yellow dot; no dot indicates OFF state.

PANEL METER TITLE		
TAG45678 STATE1	TAG45678 1234.56	TAG45678 STATE2 ●
TAG45678 1234.56	TAG45678 STATE2 ●	TAG45678 1234.56
TAG45678 STATE2 ●	TAG45678 STATE1	TAG45678 STATE1
TAG45678 1234.56	TAG45678 1234.56	TAG45678 1234.56

Figure 110 Panel meter

Overview

Displays value and status of up to twelve analog and digital signals and variables in a list format. The variables in an overview group can be edited.

OVERVIEW GROUP 1		11:30
TAGNAME1	0.00	DEGF
TAGNAME2	1000.00	DEGF
TAGNAME3	0.00	DEGF
TAGNAME4	ON	
TAGNAME5	OFF	
TAGNAME6	0.00	DEGF
TAGNAME7	0.00	DEGF
TAGNAME8	0.00	DEGF
TAGNAME9	0.00	DEGF
TAGNAME10	0.00	DEGF
TAGNAME11	0.00	DEGF
TAGNAME12	0.00	DEGF

Figure 111 Overview

Description

A signal is an identifier of a configuration element and can not be edited on this display.

A variable is a digital or analog tagged element of a control configuration which allows operator input to connected function blocks. The Overview display lets you edit values or discrete statuses of variables that affect your process.

Table 88 Overview details

Feature	Description
TAG NAME n	Name of variable or signal.
Value or state	Current value or state of the variable or signal. Press Enter to edit a variable. A popup window shows the tag name and value or state. You can change an analog variable to any value within its configured limits, and a digital variable to its ON or OFF state. Press Enter to keep the changes or press Escape to cancel the changes.



TIP

If you enter a new value or state for a variable that is not accepted, the variable might be getting its value or state from another source, namely, a Recipe Load function block within the controller's configuration. Consider reconfiguring the controller.

Other Displays

Help

Up to 10 pages of custom help messages may be accessed under the Help keys. These displays may also be configured to appear under the Display Groups keys under the display.

MESSAGES
PAGE 1
START-UP NOTES: USE RECIPE #1 AFTER SHUTDOWN. CHANGE SETPT TO 450. SHUT OFF PUMP#1. TURN ON WATER VALVE. RESET LIMIT CONTROL. VERIFY WATER LEVEL ON TANK#1.

Figure 112 Help (messages) display

Data Storage

Overview

Data Storage lets you store data from the controller on a floppy disk or ZIP disk. Trends, a point log, alarms, and events are collected in separate files on a diskette for later analysis and review on a PC with SDA data analysis software.

Data storage overall process

PC with:

1. LeaderLine Control Builder or User Utility
2. SDA for analyzing stored data

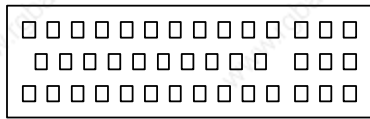
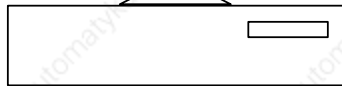
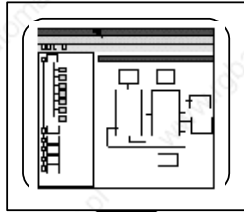

Controller



Step 1: Configure data storage
Configure Data Storage Sets (.DSS) using Control Builder or User Utility.

Step 2: Transfer configuration from PC to Controller
Transfer Data Storage Sets to Controller by one of three methods:

1. Download configuration (which includes .DSS) from Control Builder to Controller.
2. Download .DSS file from User Utility to Controller.
3. a) Save .DSS file to diskette
b) Insert .DSS disk in Operator Interface
c) Load Data Storage Settings from .DSS disk to the Controller.

Step 3: Initialize and begin storage

- 1a. Pre-initialize optional ZIP diskette on a PC using Data Storage Utility (Model1041)
- 1b. Initialize a blank floppy disk in Operator Interface (OI).(Model 551/552/1041)
2. Process data (trends, point log, alarms, events) is stored to Diskette according to Storage Control settings.

Step 4: Analyze stored data

1. Remove diskette with stored process data.
2. View stored data on PC with Software Data Analysis (SDA) software.

Step 5 (optional): Transfer configuration to another Controller
To transfer Data Storage Settings from one Controller to another:

1. Store .DSS settings to OI diskette.
2. Insert this diskette into second Controller's OI.
3. Load Data Storage Settings to the second Controller.

Operator Interface example
Model 551



Figure 113 Data storage process

Note that configuration and analysis are done on a PC and operation is done through the Operator Interface.

What can be stored

You can store the following data types:

- 2 trend groups of up to 12 points each.
- 150 alarm state changes (on-to-off or off-to-on). State changes of all points in all alarm groups are stored.

- 150 event state changes (on-to-off or off-to-on). State changes of all points designated as events are stored. An event is any digital signal added to the event group. These can include setpoint profile events and setpoint schedule events as well as any other digital signals added to the event group.
- A Point Log of 2000 records where each record contains sampled values or states of up to 12 points.

What can not be stored

Setpoint Programs, instrument configurations, recipes, variables, diagnostics, and calibrations are not part of the Data Storage feature.

Storage capacity (floppy disk)

Floppy disk storage capacities for all data types except trends are shown above. Capacity for trends is inversely proportional to the number of trend points and the storage time interval (that is, the time between trend samples). That is, the shorter the storage interval and the more points being stored, the sooner the disk will reach capacity. For example, when storing 2 trend groups of 12 points each at a storage interval of 2 seconds, the floppy disk will be filled in a few hours. Conversely, when storing 1 trend group of 3 points at a storage interval of 30 minutes, the floppy disk could take several months to be filled.

Calculating storage capacity (floppy disk)

Use the following formula to calculate the disk capacity in hours.

$$\text{Disk Capacity (hours)} = \frac{\text{Disk Factor} * R1}{F1 + (F2 * (R1 / R2))}$$

where

Disk Factor is based on which data types are stored:

398: Trend storage only

394: Trends, Alarms & Events

347: Trends, Alarms & Events, Point Log

R1 = storage rate (in seconds) for Trend 1

R2 = storage rate (in seconds) for Trend 2

F1 = point factor for Trend 1. See Table 89.

F2 = point factor for Trend 2. See Table 89.

Table 89 Data storage point factors

For this number of points in a trend:												
0	1	2	3	4	5	6	7	8	9	10	11	12
Use this Point Factor:												
0	14.00	20.16	26.53	33.60	38.77	45.82	50.40	56.00	63.00	72.00	84.00	84.00

Example storage capacity calculation (floppy disk)

Trend 1 = 6 points, rate 30 seconds

Trend 2 = none

Point Log = OFF

Alarms and Events = ON

Calculation:

Disk factor = 394

Point Factor (Trend 1) = 45.82

Point Factor (Trend 2) = 33.60

$$\text{Disk capacity (hours)} = \frac{394 * 30}{45.82 + (0 * (30/0))} = 258 \text{ hours}$$

Zip drives

Preinitialize Zip disks on a PC using DSU

If the Operator Interface has the optional Zip drive installed, we strongly recommend that you pre-initialize the Zip disks on a PC using the Data Storage Utility (DSU) - See Table 90. This program is part of the User Utility package. If you do not pre-initialize your data storage Zip disks using DSU, the initialization process on the Operator Interface may take several hours.

Note that DSU cannot be used for floppy disks.

Capacity of a Zip disk

The following formula can be used to compute the capacity of any trend file on a Zip disk:

$$\text{Capacity (in hours)} = \frac{6560 * R}{F}$$

where:

R is the storage rate of the trend, in seconds.

F is the point factor for the trend. See Table 88.

Note that each trend file on a Zip disk is 24MB, so the capacity of each trend file is independent of any other data storage files on the disk.

Estimated Zip drive capacity	Sample Rates		Estimated Zip Drive Capacity Per Trend File				
	Number of Trends	Total Number of Points	2 Sec.	10 Sec.	30 Sec.	2 Min.	5 Min.
	1 or 2	6	11.9 days	59.5 days	178 days	714 days	1785 days
		12	6.5 days	32.5 days	97 days	388 days	970 days
Note: On a Zip drive each trend is allocated 24 megabytes							

Table 90 Preinitializing ZIP Diskette

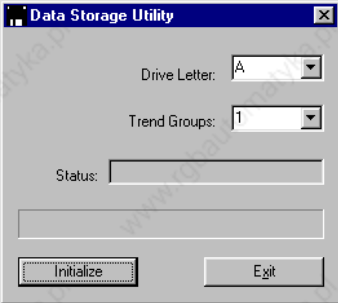
Step	Action
1	Insert the 100MB/Zip disk into your PC drive.
2	Start the User Utility Program under Windows
3	<p>From the menu, select Maintenance, then data Storage Utility. The dialog box appears.</p> 
4	Click on Drive Letter to specify the drive on your PC (A, B, etc.).
5	Click on Trend Groups to specify the number of Trend Groups that the Operator Interface will need (1 or 2)
6	Click on Initialize to prepare the disk for storage. Each trend group takes about four minutes.
7	Exit DSU.
8	Remove disk, insert it into the operator Interface, and initialize it. See Initializing Disk under this section entitled "Data Storage Operation".

Rollover

If a data type is configured for rollover storage, the space allocated for it will fill up then the oldest data will be replaced with new incoming data (as a circular buffer). For example, if alarm storage is set to rollover, 150 alarms will be stored. The 151st alarm will replace the oldest alarm, the 152nd alarm will replace the next oldest alarm, and so on.

Storage modes

Trends, Point Log, and Alarms/Events can be stored in Continuous or Batch modes. In addition, Point Log can be stored in On Command mode. See Table 91.

Table 91 Storage modes

Mode	Description
Continuous	Data is sampled at the storage interval.
Batch	Data is sampled at the storage interval, but also a Batch Enable Signal separates the sampled data into numbered batches. Batch #1 begins when the Batch Enable Signal turns on, and ends when the signal turns off. Batch #2 begins when the Batch Enable Signal turns on, and ends when the signal turns off, etc. No batch mode data is collected while the Batch Enable Signal is off. The Batch Enable Signal does not affect data being stored as Continuous or On Command.
On Command	Point Log mode only. Point Log data is sampled once when the Point Log storage is enabled, but not after each storage interval. That is, a "snapshot" of Point Log data is stored once. This snapshot is triggered by the off-to-on transition of the Enable Signal for Point Log.
Off	No data is being stored.

Storage intervals

When data storage is enabled, samples are taken at regular intervals known as the storage intervals. These intervals can be from a few seconds to 30 minutes, or more for Point Log. Each data type has its own storage interval.

In Continuous and Batch modes, the storage interval determines how often data is sampled and stored. In these modes for trends and alarms/events, data is first sampled when storage is enabled and again at equally spaced intervals thereafter. For example, if trend storage is enabled at 2:03 p.m. and the interval is 10 minutes, trend storage occurs at 2:03, 2:13, 2:23, etc. until storage is disabled.

In Continuous and Batch modes for Point Log, data is first sampled after storage is enabled but not until the programmed Start Time. Data is sampled at equally spaced intervals after the Start Time. For example, suppose the Start Time is 3:00 p.m. and the storage interval is 10 minutes. If storage is enabled at 2:03 p.m., the first sample will occur at 3:00 and every 10 minutes thereafter. If storage is disabled at 3:35 and enabled at 3:42, storage will resume at 3:50. Notice that the interval is synchronized to the Start Time.

The storage interval for Point Log can also be once a day or once a month, synchronized to the Start Time.

In On Command mode for Point Log, there is no storage interval or Start Time. A single sample of Point Log data is taken when the Point Log Enable changes from off (disable) to on (enable).

How storage is controlled

Depending on the data type being stored, there are two or three levels of control for data storage. For storage of a data type to occur, all levels of control must be enabled. If any level is disabled, that data type will not be stored. Figure 114 shows the controls that must be enabled for each storage mode and data type. The left side shows the three data types and their possible storage modes (only one storage mode is in effect for any data type). For example, trend storage is either batch or continuous, not both. The arrows show the conditions required for that storage to take place. For example, trend batch storage requires three controls to be enabled: 1) the Trend Storage Control, 2) the Batch Command Control, and 3) the Data Storage Control. Notice that the Batch Command Control applies only to those data types in batch storage mode. Also notice Data Storage Control enables all storage; if it is disabled no storage will occur.

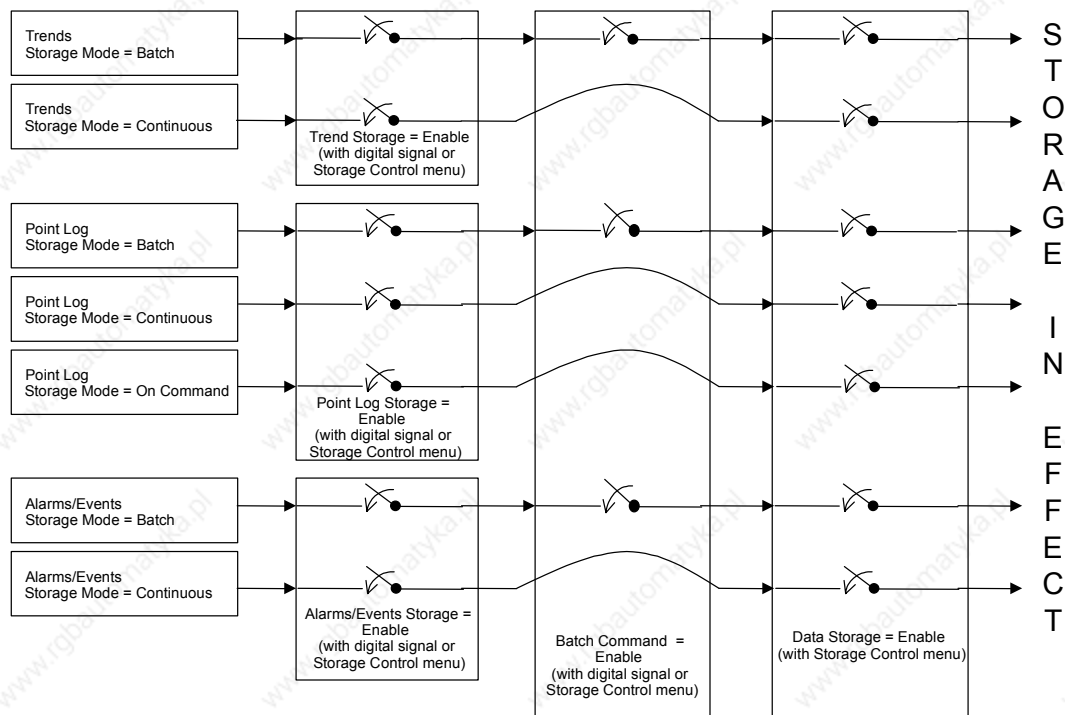

Figure 114 Required enabled controls for storage

Three levels of control

Data storage enabler

The highest level of control is the Data Storage control item found on the Storage Control menu under Data Storage (first line in Figure 115). It disables data storage for all trends, alarms, events, and point log. It must be enabled for any storage to occur.

STORAGE CONTROLS	
DATA STORAGE	ENABLE
BATCH COMMAND	START
TRENDS	ENABLE
POINT LOG	ENABLE
ALARMS/EVENTS	ENABLE

Figure 115 Storage control menu with all enablers shown

Data type enabler

The second level of control is the Data Type Enabler. Each data type (trends, point log, and alarms/events) has its own Enabler that turns storage on and off for that data type. Each of these Enablers can either appear on the Storage Control menu (third, fourth, and fifth lines in Figure 115) or can be programmed as a digital signal. For example, if the Trend Enabler is programmed as a digital signal, it will not appear on the Storage Control menu. In this case, trend storage is enabled when the digital signal turns on and is disabled when the signal turns off.

The Point Log Enabler functions differently depending on the storage mode. In Continuous and Batch modes, it enables Point Log storage to begin at the Start Time and at every storage interval thereafter. In On Command mode, when it changes from off (disable) to on (enable), it causes a single sample of Point Log data to be stored at that moment (Figure 118).

Batch enabler

The third level of control is the Batch Enabler. It starts and stops storage for all data types configured for Batch storage; it does not affect Continuous or On Command storage. It appears either on the Data Storage Control menu—as Batch Command (second line of Figure 115)—or it is programmed as a digital signal.

Example of trend enabling

In Figure 116, notice that no continuous trend storage occurs unless Trend Enable and Data Storage Enable are both on (enabled). For batch trend storage, notice that all three enables must be on.

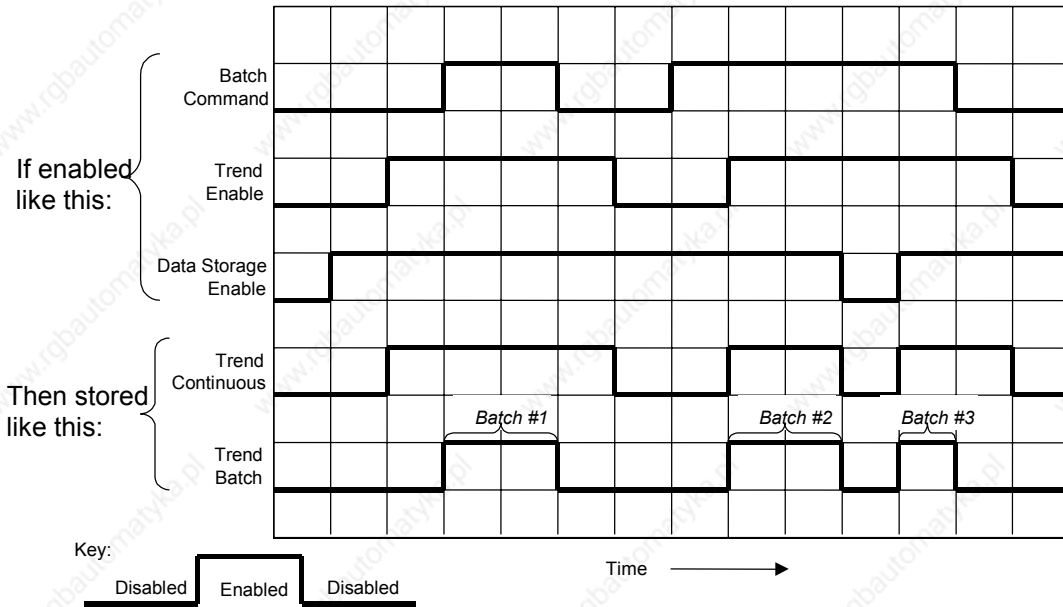

Figure 116 Trend storage: enable conditions

Example of alarm/event enabling

As with Trends, no continuous alarm/event storage occurs unless Alarm/Event Enable and Data Storage Enable are both on (enabled). For batch alarm/event storage, all three enables must be on.

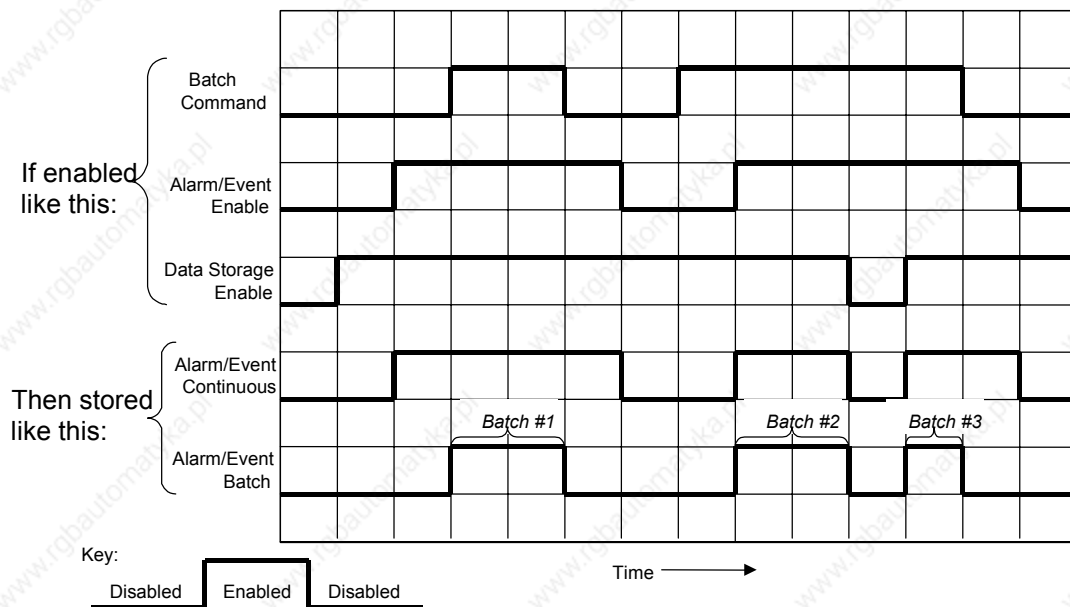

Figure 117 Alarm/event storage: enable conditions

Example of point log enabling

In Figure 118, notice that no continuous Point Log storage occurs unless Point Log Enable and Data Storage Enable are both on (enabled). For batch Point Log storage, notice that all three enables must be on. Notice that storage does not actually occur until the Start Time occurs, and then at every Storage Interval thereafter.

For On Command storage, notice the samples are taken the instant Point Log Enable is enabled but not at intervals.

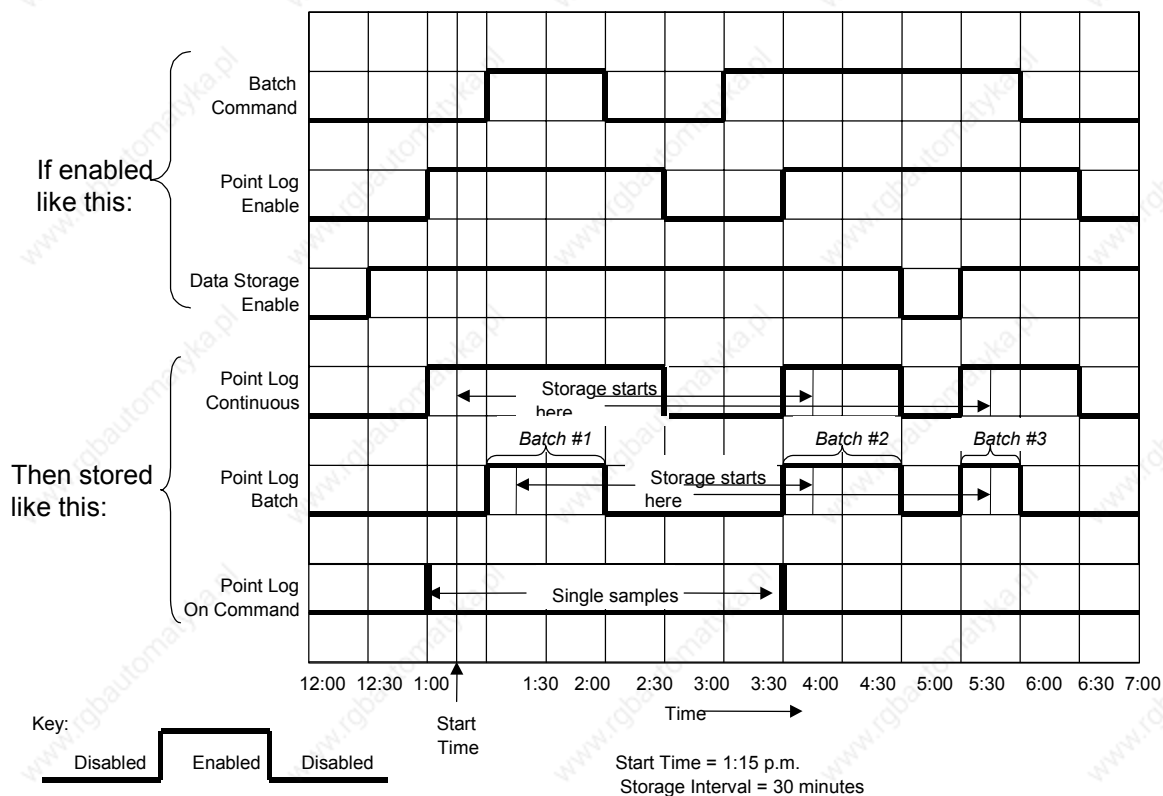

Figure 118 Point log storage: enable conditions

How to analyze stored data

With the stored data on a floppy disk, use SDA on a PC to review the data graphically or in tabular form. Refer to SDA documentation for details.

Data Storage Operation

Access

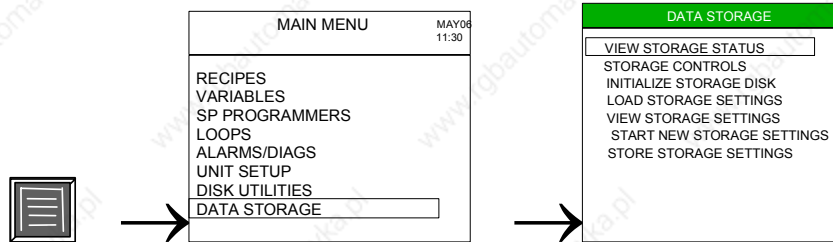

Typical data storage tasks

Task	Page
Viewing storage status.	171
Controlling storage (3 methods): <ul style="list-style-type: none"> Start/stop all storage with DATA STORAGE item on Storage Control menu. Start/stop a particular storage file's storage (2 ways): <ul style="list-style-type: none"> with its external enable discrete, or with its enabler on the Storage Control menu. Start/stop all storage batches with Batch menu item or with BATCH CONTROL discrete. 	173
Initializing a new diskette.	174
Loading storage settings from diskette to controller.	175
Viewing current storage settings.	176
Starting new storage settings.	177
Storing storage settings from controller to disk.	178
Viewing Status Line storage indicator.	178
Analyzing data stored on disk.	See SDA manual (Part #51-52-25-51).

View storage status

This function shows the remaining diskette capacities for each data type along with other storage statuses.



TIP

This display can be configured for access under any Display key 1-5 [8].

DATA STORAGE STATUS		JAN31 11:30
	REMAINING	
TREND 1	02 10 15	Y
TREND 2	01 05 20	Y
POINT LOG	ROLL	N
ALARM SAMPLES	100	Y
EVENT SAMPLES	95	Y
WARNING LEVEL %	90	
BATCH NUMBER	0 OFF	
SYSTEM: NORMAL		
DISK: NORMAL		
ENABLE STORAGE ENABLED		

Figure 119 View storage status

Table 92 View storage status details

Feature	Description
Y	Indicates that storage is enabled for this data type. See <i>Storage controls (page 173)</i> . See External Enable (Table 94).
N	Indicates that storage is disabled for this data type. See <i>Storage controls (page 173)</i> . See External Enable (Table 94).
TREND 1 XX XX XX Or TREND 1 ROLL	Days, Hours, Minutes remaining on diskette for Trend 1 data Or Trend 1 is in Rollover, which means when the trend space is full on the disk, storage will roll over (continue) and will replace the existing data. No Disk Warning will be given. See WARNING LEVEL %.
TREND 2 XX XX XX Or TREND 2 ROLL	Days, Hours, Minutes remaining on diskette for Trend 2 data Or Trend 2 is in Rollover, which means when the trend space is full on the disk, storage will roll over (continue) and will replace the existing data. No Disk Warning will be given. See WARNING LEVEL %.
POINT LOG XXX Or POINT LOG ROLL	Number of point log samples remaining on diskette Or Point Log is in Rollover, which means when the point log space is full on the disk, storage will roll over (continue) and will replace the existing data. No Disk Warning will be given. See WARNING LEVEL %.

Feature	Description
ALARM SAMPLES XXX Or ALARM SAMPLES ROLL	Number of alarms remaining on diskette Or Alarm storage is in Rollover, which means when the alarm space is full on the disk, storage will roll over (continue) and will replace the existing data. No Disk Warning will be given. See WARNING LEVEL %.
EVENT SAMPLES XXX Or EVENT SAMPLES ROLL	Number of events remaining on diskette Or Event storage is in Rollover, which means when the event space is full on the disk, storage will roll over (continue) and will replace the existing data. No Disk Warning will be given. See WARNING LEVEL %.
WARNING LEVEL %	When any data type (trend, point log, or alarms/events) reaches this % of its disk capacity, a disk warning message is displayed.
BATCH NUMBER	Current batch number of all data batches. Zero (0) indicates batch storage has not started. Current batch status (ON/OFF) indicates whether batch storage is active.
SYSTEM:	Indicates status of data storage system
DISK:	Indicates status of diskette
ENABLE STORAGE	Indicates whether all data storage is enabled or disabled. DISABLED means no storage is occurring, regardless of Y/N status above. See <i>Storage controls (page 173)</i> .

Storage controls

This screen lets you enable and disable part or all of data storage.

STORAGE CONTROLS	
DATA STORAGE	ENABLE
BATCH COMMAND	START
TRENDS	ENABLE
POINT LOG	ENABLE
ALARMS/EVENTS	ENABLE

Figure 120 Storage controls

Table 93 Storage controls details

Feature	Description
DATA STORAGE	<p>ENABLE: Select this to enable all of data storage. Must be selected for <i>any</i> storage to occur.</p> <p>DISABLE: Select this to disable all of data storage. If disabled, no storage will occur.</p>
BATCH COMMAND*	<p>START: Select this to start batch storage.</p> <p>STOP: Select this to stop batch storage.</p> <p>This affects only batch data; it does not affect continuous or on-command data. Batch data collected between a start and the following stop is assigned a batch number. With each selection of START, the batch number increments by 1.</p>
TRENDS*	<p>ENABLE: Select this to enable trend storage.</p> <p>DISABLE: Select this to disable trend storage. If disabled, no trend storage will occur.</p>
POINT LOG*	<p>ENABLE: Select this to enable Point Log storage.</p> <p>DISABLE: Select this to disable Point Log storage. If disabled, no Point Log storage will occur.</p>
ALARMS/EVENTS*	<p>ENABLE: Select this to enable Alarm/Event storage.</p> <p>DISABLE: Select this to disable Alarm/Event storage. If disabled, no Alarm/Event storage will occur.</p>

* Does not appear if programmed as an external enable.

Initialize storage disk

Formats the diskette for data storage. Use this to continue the current storage settings onto a new diskette.

After initializing, a separate file is allocated for each data storage type, using the following filename extensions.

(Do Not use backslashes \ or decimal points in file name – Use DOS compatible file names)

- .LNT = Trend
- .LNP = Point Log
- .LNA = Alarms
- .LNE = Events

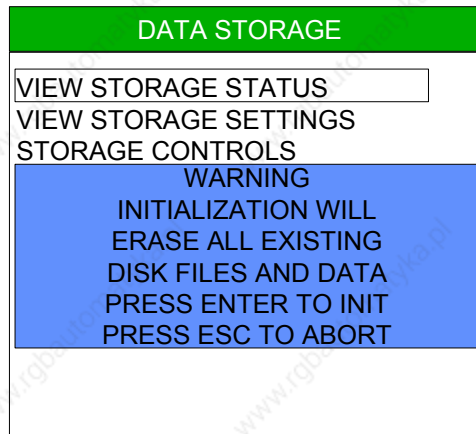

Figure 121 Initialize storage disk

Press Enter to initialize the disk or press Escape to cancel and return to the Data Storage menu.

Load storage settings

Select this to load data storage settings from the diskette to the controller. Data Storage Setting files have extension .DSS. Use this function to:

- load data storage settings that were created on a PC with Control Builder, or
- load data storage settings that were stored to disk from another controller.

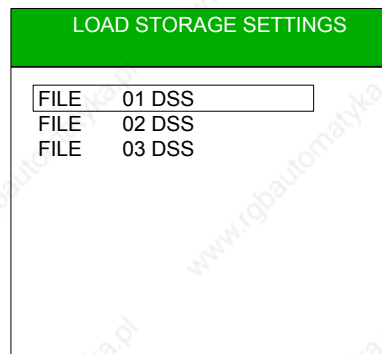

Figure 122 Load storage settings

Move cursor to desired file and press Enter. A message then warns you that the load will overwrite the existing storage settings. To complete the load, press Enter, or to abort it press Escape.



TIP

To begin storage using the loaded settings, select Start New Storage Settings. See *Start new storage settings (page 177)*.

View storage settings

This lets you view (not change) the settings—as configured in the Control Builder—of trends, point log, and alarms/events. All these settings comprise the .DSS file, which can be loaded from the diskette to the controller, or stored from the controller to the diskette.

Select a data type and press Enter to see the settings for that data type.

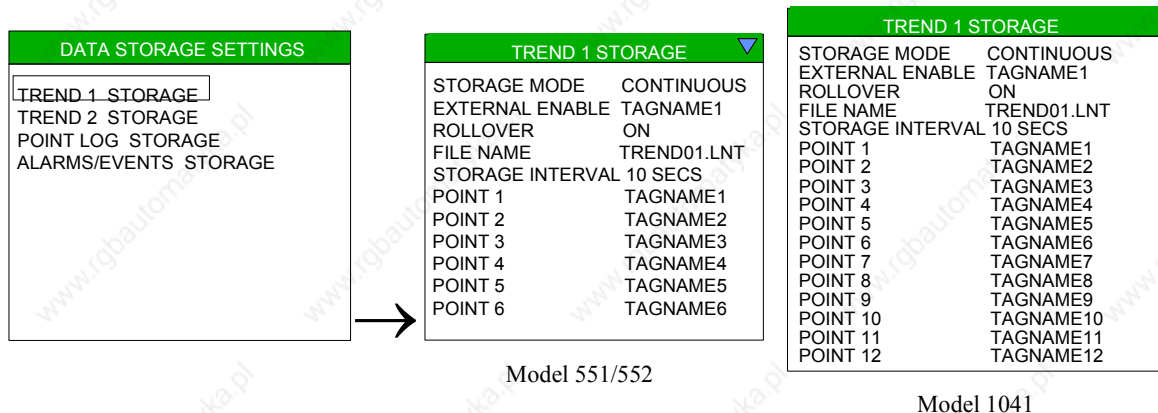

Figure 123 View storage settings

Table 94 View storage setting details

Feature	Description
STORAGE MODE	<p>CONTINUOUS: data is sampled periodically at the storage interval.</p> <p>BATCH: data is sampled periodically at the storage interval and is separated into numbered batches.</p> <p>ON COMMAND: Point Log data is sampled once only, when the External Enable switches from off to on or when you change Point Log from Disable to Enable on the Storage Control menu.</p>
EXTERNAL ENABLE	<p>Name of digital signal that is controlling the storage for the selected data type. When this digital signal is on, the data type's storage is enabled; when off, disabled.</p> <p>If NONE, then storage for this data type is controlled through that data type's enabler on the Storage Control menu (Figure 120).</p>
ROLLOVER	<p>When rollover is ON, the data type's storage will never fill up the disk but will continually replace existing disk data with new incoming data. When rollover is OFF, the disk will eventually fill up with data and will not accept more incoming data unless a new disk is inserted.</p>
FILE NAME	<p>8 character file name of data being stored to disk. This name is used to identify the file you want to replace on a PC. The filename extension indicates the type of data in the file: (Do not use backslashes \ or decimal points in file name)</p> <p>.LNT = Trend .LNP = Point Log .LNA = Alarms .LNE = Events</p>

Feature	Description
STORAGE INTERVAL	How often data is sampled in continuous or batch modes. Point Log On Command does not use a storage interval.
START TIME / INTERVAL	For Point Log, select this to view the Start Time and Storage Interval.
POINT 1 ... POINT 12	For all storage except Alarms/Events, up to 12 Points being stored.

Start new storage settings

Formats the diskette for data storage using the new storage settings. Use this after loading storage settings.

After initializing, a separate file is allocated for each data storage type, using the following filename extensions.

- .LNT = Trend
- .LNP = Point Log
- .LNA = Alarms
- .LNE = Events

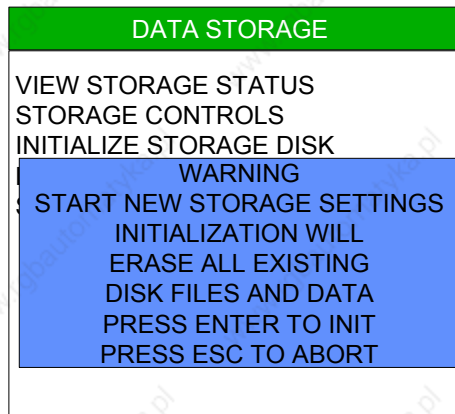

Figure 124 Start new storage settings

Press Enter to initialize the disk or press Escape to cancel and return to the Data Storage menu.

Store storage settings

This lets you store the controller's storage settings to disk. You can view the current settings under *View storage settings* (Figure 123).

You can store different settings to disk, then load them when needed.

STORE STORAGE SETTINGS	
FILE	FILE 01 DSS
FILES ON DISK:	
	FILE01 DSS
	FILE02 DSS
	FILE03 DSS
	RECORD01 DSS
	RECORD02 DSS

Figure 125 Store storage settings

Use the Increment and Decrement keys to select a filename and number for the settings. A .DSS extension will automatically be added to the filename. Press Enter to proceed with the load.

Status line storage indicator

A storage indicator (“S”) appears on the status line at the bottom of the display when data storage is active. When the indicator is not visible, the user can determine why storage is inactive by accessing the Storage Status display (Figure 119) or the Storage Controls display (Figure 120).

Maintenance

Overview

Several maintenance functions are performed from the Unit Setup selection under the Main menu. Others are hardware replacement procedures.

Unit Setup

Access

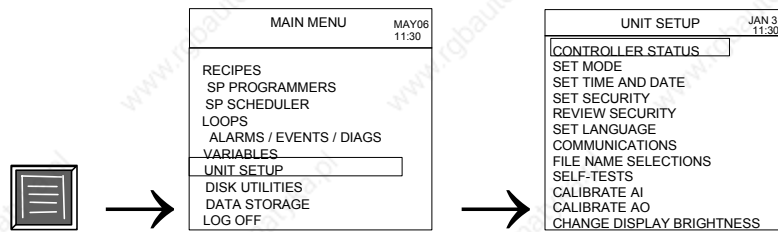

Description

Unit Setup gives you access to maintenance functions of the unit, such as calibration, setting the clock, setting security access, and self-tests.

Controller Status

This is a read-only display giving the status of various controller parameters.

CONTROLLER STATUS	
MODE	RUN
REV LEVEL	2.00
FREQUENCY	60 HZ
LOOP CAPACITY	16
PRODUCT TYPE	UMC800
CYCLE TIME (S)	0.50

Figure 126 Controller status

Table 95 Controller status details

Feature	Description																
MODE	FAULT, PROGRAM, OFFLINE, RUN																
REV LEVEL	Revision level of the Controller software.																
FREQUENCY	Line frequency. Used for configuring the conversion time of the A/D converter.																
LOOP CAPACITY	Maximum number of loops allowed by the controller. Loading more than this number into the controller will result in a diagnostic message and will erase the entire configuration from controller memory.																
PRODUCT TYPE	UMC800 (Read Only)																
CYCLE TIME	<p>The analog control cycle time in seconds. This value is determined from the required number of analog inputs and the execution time estimated from the configured control scheme.</p> <p>The Controller first determines the amount of time required based on the number of AI cards installed in the system. These times are in milliseconds and are given below.</p> <table border="1"> <thead> <tr> <th>Cycle time is this</th> <th>For this many AI cards</th> </tr> </thead> <tbody> <tr> <td>333</td> <td>None</td> </tr> <tr> <td>333</td> <td>1</td> </tr> <tr> <td>333</td> <td>2</td> </tr> <tr> <td>450</td> <td>3</td> </tr> <tr> <td>600</td> <td>4</td> </tr> <tr> <td>750</td> <td>5</td> </tr> <tr> <td>900</td> <td>6</td> </tr> </tbody> </table> <p>Next, the execution time of the blocks in the control scheme is estimated. Cycle time is made equal to the greater of the two values. The value displayed will not exactly equal the numbers shown because it is converted to an even multiple of the realtime operating system tick rate.</p>	Cycle time is this	For this many AI cards	333	None	333	1	333	2	450	3	600	4	750	5	900	6
Cycle time is this	For this many AI cards																
333	None																
333	1																
333	2																
450	3																
600	4																
750	5																
900	6																

Set Mode

This lets you change the Controller's operating mode. It has the same effect as if you changed the mode switch on the controller.

The current mode is indicated on the bottom right of the display.

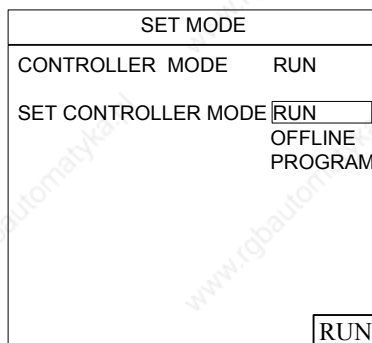

Figure 127 Set mode

Table 96 Set mode details

Feature	Description
CONTROLLER MODE	Current mode of the controller. See Table 97.
SET CONTROLLER MODE	<p>RUN: Select this to resume running the process.</p> <p>OFFLINE: Select this before performing these tasks:</p> <ul style="list-style-type: none"> • Calibration (A/I only) • Downloading a .DSS (data storage) file. <p>PROGRAM: Select this before performing these tasks:</p> <ul style="list-style-type: none"> • Calibration • Downloading a .FBD (configuration) file.

Table 97 Controller modes defined

Mode	Function Blocks Executed?	Outputs Updated?	Effect upon return to RUN mode?
RUN	Yes	Yes	None
OFFLINE	No	No	Resumes running
PROGRAM	No	No	Cold start



TIP

- If the controller switch is set to RUN but the mode was set to PROGRAM or OFFLINE here, following a power cycle the mode will return to RUN.
- Changing from Program to Run causes data in RAM (setpoint profiles, recipes) to be copied to non-volatile (FLASH) memory.
- In a cold start, all data storage and display buffers are cleared and accumulated values of some function blocks (such as totalizers) are reset.
- In a warm start, all buffered data and values are retained and the process resumes where it left off.

Set Time and Date

Allows you to set the time and date displayed on screens.

SET TIME AND DATE	
HOURS	11
MINUTES	50
MONTH	MAR
DAY	1
YEAR	2001
DATE FORMAT	US

Figure 128 Set time and date

Table 98 Set time and date details

Feature	Description
HOURS	Enter the hours for the current time.
MINUTES	Enter the minutes for the current time. Clock is set when you press Enter.
MONTH	Enter the current month.
DAY	Enter the current day of the month.
YEAR	Enter the current year.
DATE FORMAT	US: MMDDYY INT: DDMMYY

Press Escape to get a popup menu where you can save or ignore the changes made.

Set Security/Review Security

This feature lets you secure various displays or features with a security code. If security is enabled for a display or function, access is not possible without first entering the code.

The controller must be in Program mode to set security. In other modes, Review Security allows read-only access to the security parameters.

SET SECURITY		REVIEW SECURITY	
ENABLE SECURITY	NO	ENABLE SECURITY	NO
ENGINEER SECURITY CODE	0	SET UNIT	NO
SET UNIT	NO	FUNCTION BLOCK EDIT	NO
FUNCTION BLOCK EDIT	NO	EDIT MENUS	NO
EDIT MENUS	NO	AUTO/MANUAL	NO
OPERATOR SEC CODE	0	LSP/RSP	NO
AUTO/MANUAL	NO	SPP/SPS OPERATION	NO
LSP/RSP	NO	SETUP	NO
SPP/SPS OPERATION	NO	RECIPE/VAR. EDIT	NO
SETUP	NO	DISK UTIL / DATA STORAGE	NO
RECIPE/VAR. EDIT	NO	LOG ON/OFF	NO
DISK UTIL / DATA STORAGE	NO		
LOG ON/OFF	NO		

Figure 129 Set security/review security

Table 99 Set security details

Feature	Description
ENABLE SECURITY	This is a master enabling switch. Set this to YES to enable security on any of the engineer or operator secured items that are also set to YES. <i>If this is set to NO, no engineer or operator secured items will be secured, even if they are set to YES.</i>
ENGINEER SECURITY CODE	This is a higher level of security than the operator security code because it secures access to “off-line” functions such as calibration. Choose a 3-digit code which will be used to secure the item below.
SET UNIT	Set this to YES to secure the displays and menu items in Table 100 under SET UNIT. Set to NO to allow unrestricted access.
FUNCTION BLOCK EDIT	Set this to YES to secure Edit Device Control and HOA EDIT displays. Set to NO to allow unrestricted access. See Table 100 for affected items
EDIT MENUS	Set this to YES to secure Edit Device Control and HOA operate display Edit menus. Set to NO to allow unrestricted access. See Table 100 for affected items.
OPERATOR SECURITY CODE	Enter a 3-digit code which will be used to secure the items below.
AUTO/MANUAL	Set this to YES to secure loop mode AUTO/MANUAL operation. Set to NO to allow unrestricted access. See Table 100 for affected items.
LSP/RSP	Set this to YES to secure changing between Local and Remote Setpoints. Set to NO to allow unrestricted access. See Table 100 for affected items.
SPP/SPS OPERATION	Set this to YES to secure setpoint program and schedule operation. Set to NO to allow unrestricted access. See Table 100 for affected items.
SETUP	Set this to YES to secure access to setup items. Set to NO to allow unrestricted access. See Table 100 for affected items.
RECIPE/ VAR. EDIT	Set this to YES to secure recipe and variable operation. Set to NO to allow unrestricted access. See Table 100 for affected items.

Feature	Description
DISK UTIL / DATA STORAGE	Set this to YES to secure access to disk utilities, data storage controls, and load data storage settings). Set to NO to allow unrestricted access. See Table 100 for affected items.
LOG ON/OFF	Set this to YES to secure access to the Log On/Off display. See Table 100 for affected items.

Accessing a secured area

1. The security access display is shown when you are about to enter a secured area (Figure 130).
2. Use Increment/Decrement and Left Arrow to select the code. Press Enter to gain access.

SECURITY ACTIVE
ENTER CODE
000
FOR ACCESS

Figure 130 Security access



TIP

1. If you forget your security code, see Security Bypass Procedure.
2. An item is secured only if all the following conditions are met.
 - ENABLE SECURITY is set to YES.
 - Non-zero security code.
 - Security category (for example, SETUP) is set to YES.
3. If a display or function is secured, then all displays and functions subordinate to it are also indirectly secured. Once you enter the security code for a display or menu, you do not have to enter a security code for each subordinate display and function. For example, Loops is under the SETUP security category. If SETUP security is enabled with YES, the operator must enter the operator security code after selecting Loops from the Main Menu. Once this code is entered, all menus and displays under Loops are accessible.

Table 100 summarizes the displays and menu items which can be secured.

Table 100 Displays and functions that can be secured

	ENG SEC CODE			OPERATOR SECURITY CODE						
	SET UNIT	FB EDIT	EDIT MENUS	AUTO / MAN	LSP / RSP	SET-UP	SPP OPERATION	RECIPE / VAR EDIT	DISK UTIL/ DATA STORAGE	LOG ON/OFF
UNIT SETUP*										
SET MODE	X									
SET TIME & DATE	X									
SET SECURITY	X									
SET COMM A PORT	X									
SET COMM B PORT	X									
FILE NAME SELECTION						X				
SELF-TESTS	X									
CALIBRATE AI	X									
CALIBRATE AO	X									
SINGLE LOOP TREND DISPLAY				X						
LOOP TUNING DISPLAY				X						
LOOP TUNE CONSTANTS DISPLAY				X						
LOOP CONTROL SETUP DISPLAY				X						
SWITCH SP					X					
CARBON LOOP SETUP DISPLAY				X						
LOOP ALARM SETPTS DISPLAY				X						
LOOP LIMITS DISPLAY				X						
8-LOOP SUMMARY DISPLAY				X						
4-LOOP FACEPLATE DISPLAY				X						
3-LOOP FACEPLATE DISPLAY				X						
2-LOOP FACEPLATE DISPLAY				X						
SINGLE LOOP NUMERIC DISPLAY				X						
A/M BIAS DISPLAY				X						
LOOP CONTROL DISPLAY				X						
SWITCH SP					X					

Maintenance
Set Security/Review Security

	ENG SEC CODE			OPERATOR SECURITY CODE						
	SET UNIT	FB EDIT	EDIT MENUS	AUTO / MAN	LSP / RSP	SET-UP	SPP OPERATION	RECIPE / VAR EDIT	DISK UTIL/ DATA STORAGE	LOG ON/OFF
RECIPES*										
EDIT						X				
LOAD								X		
MAIN MENU										
LOOPS						X				
SP PROGRAMMERS						X				
SP SCHEDULER						X				
DISK UTILITIES									X	
DATA STORAGE*										
STORAGE CONTROLS									X	
LOAD STORAGE SETTINGS									X	
SINGLE SPP OPERATE DISPLAY										
OPERATE							X			
SETPOINT SCHEDULER OPERATE							X			
RECIPE LOAD DISPLAY								X		
DEVICE CONTROL OPERATE DISPLAY			X							
DEVICE CONTROL EDIT DISPLAY										
EDIT TIMERS		X								
RESET FAILURE				X						
HOA OPERATE DISPLAY			X							
HOA EDIT DISPLAY										
HOA SOURCE		X								
SET STATE				X						
OVERVIEW DISPLAY								X		
LOG ON/OFF										

*Accessed through Main Menu.

X = this item and items subordinate to it can be secured

Set Language

Sets the language of all displays.

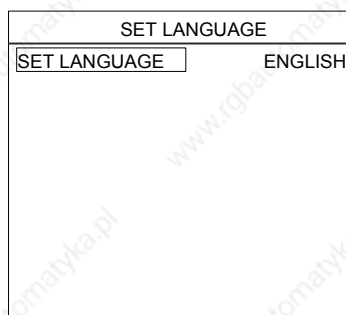

Figure 131 Set language

Table 101 Set language details

Feature	Description
SET LANGUAGE	Choose between English, French, Italian, Spanish, German.

Communications Menu - Model 551/552

For Model 1041 - See page 196

This function lets you:

- view and adjust communication ports COMM A and COMM B,
- view each slave device scan status and details.

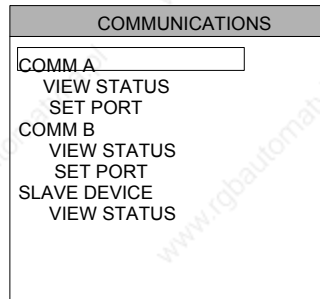

Model 551/552

Figure 132 Communications

COMM A status - Model 551/552

COMM A STATUS	
STATUS	ONLINE
MESSAGES RECEIVED	50
DATA LINK ERRORS	0
APPLICATION ERRORS	0
COMM BOARD REV	3.1

Figure 133 COMM A status - Model 551/552

Table 102 COMM A status details - Model 551/552

Feature	Description
STATUS	<p>NO BOARD: No comm board is present and the address is default 255.</p> <p>REQUIRES SETUP: Comm board and the main CPU both have default addresses. Initialize the Modbus address.</p> <p>OFFLINE: Messages on the comm link are being ignored. Check Modbus settings and enable COMM A port.</p> <p>ONLINE: Messages on the comm link are being processed.</p> <p>BOARD FAILURE: The comm board hardware has a serious failure. For example, the EEPROM failed when being written. In this condition, all communications on the Modbus link are ignored. Replace comm board.</p> <p>BOARD NOT FOUND: No comm board is installed and the address is non-default (1-254). Install comm board or set address to 255.</p>
MESSAGES RECEIVED	Number of messages that were received and processed correctly.
DATA LINK ERRORS	Number of errors reported by the comm board.
APPLICATION ERRORS	Number of messages that were responded to with an exception error.
COMM BOARD REV	Firmware revision level on the controller comm board.

Bold items are read-only.

Set COMM A port - Model 551/552

SET COMM A PORT	
STATION ADDRESS	31
BAUD RATE (BPS)	38400
PORT	ENABLE
DOUBLE REGISTER FORMAT	FPB

Figure 134 Set COMM A port

Table 103 Set COMM A port details

Feature	Description												
STATION ADDRESS	The address of the controller on the Modbus link. All devices on the link must have a unique address. The value is configurable from 1 to 247 and 255. 255 is the default address. If no communication board is installed, the default address should equal 255 to inhibit comm board diagnostics. If no communication board is installed and the default address is not 255, a diagnostic occurs.												
BAUD RATE	9600, 19200, 38400												
PORT	ENABLE: Enables the COMM A port. DISABLE: Disables COMM A port.												
DOUBLE REGISTER FORMAT (MODBUS)	Each IEEE 32-bit floating point number requires two consecutive registers (four bytes, MSB=4, LSB=1 in byte order below) starting with the register defined as the starting register for the information. The stuffing order of the bytes into the two registers differs among Modbus hosts. To provide compatibility, the Double register format is configurable. Selections are: <table border="0"> <tr> <td>FPB</td> <td>Floating Point Big Endian Format</td> <td>Byte order – 4, 3, 2, 1(DEFAULT)</td> </tr> <tr> <td>FP BB</td> <td>Floating Point Big Endian with byte-swapped</td> <td>Byte order – 3, 4, 1, 2</td> </tr> <tr> <td>FP L</td> <td>Floating Point Little Endian Format</td> <td>Byte order – 1, 2, 3, 4</td> </tr> <tr> <td>FP LB</td> <td>Floating Point Little Endian with byte-swapped</td> <td>Byte order – 2, 1, 4, 3</td> </tr> </table>	FPB	Floating Point Big Endian Format	Byte order – 4, 3, 2, 1(DEFAULT)	FP BB	Floating Point Big Endian with byte-swapped	Byte order – 3, 4, 1, 2	FP L	Floating Point Little Endian Format	Byte order – 1, 2, 3, 4	FP LB	Floating Point Little Endian with byte-swapped	Byte order – 2, 1, 4, 3
FPB	Floating Point Big Endian Format	Byte order – 4, 3, 2, 1(DEFAULT)											
FP BB	Floating Point Big Endian with byte-swapped	Byte order – 3, 4, 1, 2											
FP L	Floating Point Little Endian Format	Byte order – 1, 2, 3, 4											
FP LB	Floating Point Little Endian with byte-swapped	Byte order – 2, 1, 4, 3											



TIP

Operation is only half duplex (full duplex is not an option).

COMM B status - Model 551/552

COMM B STATUS	
STATUS	ONLINE
MESSAGES RECEIVED	50
DATA LINK ERRORS	0
APPLICATION ERRORS	0
COMM BOARD REV	3.10

Figure 135 COMM B status

Table 104 COMM B status details

Feature	Description
STATUS	<p>ON LINE: Comm is on line</p> <p>NO BOARD: No comm board is present and the address is default 255.</p> <p>BOARD FAILURE: The comm board hardware has a serious failure. For example, the EEPROM failed when being written. In this condition, all communications on the Modbus link are ignored. Replace comm board.</p> <p>BOARD NOT FOUND: No comm board is installed and the address is non-default (1-254). Install comm board or set address to 255.</p>
MESSAGES RECEIVED	Number of messages that were received from all the slave devices.
DATA LINK ERRORS	Number of errors reported by the comm board.
APPLICATION ERRORS	Number of messages that were responded to with an exception error.
COMM BOARD REV	Firmware revision level on the controller comm board.

Bold items are read-only.

Set COMM B port - Model 551/552

SET COMM B PORT	
BAUD RATE (BPS)	38400

Figure 136 Set COMM B port

Table 105 Set COMM B port details

Feature	Description
BAUD RATE	9600, 19200, 38400



TIP

Operation is only half duplex (full duplex is not an option).

View slave devices

VIEW SLAVE DEVICES		VIEW SLAVE DEVICES		VIEW SLAVE DEVICES	
PAGE 1 OF 2		PAGE 2 OF 2		SLAVE DEVICE	IN SCAN
SLAVE DEVICE	IN SCAN	SLAVE DEVICE	IN SCAN		
1	NO	9	NO	1	NO
2	YES	10	YES	2	YES
3	YES	11	YES	3	YES
4	NO	12	NO	4	NO
5	YES	13	YES	5	NO
6	NO	14	NO	6	NO
7	NO	15	NO	7	NO
8	NO	16	NO	8	NO
				9	NO
				10	YES
				11	YES
				12	NO
				13	YES
				14	NO
				15	NO
				16	NO

Model 551/552

Model 1041

Figure 137 View slave devices

Table 106 View slave devices details

Feature	Description
1 through 16	Shows scan status of up to 16 slave devices. Select a device to see more details. YES: Slave device is in scan. NO: Slave device is not in scan.

View slave details

VIEW SLAVE DETAILS	
IN SCAN	NO
PORT B STATUS	NO BOARD
SCAN ENABLED	NO
COMM STATUS	NONE
MESSAGES RECEIVED	0
DATA LINK ERRORS	0
APPLICATION ERRORS	0
ENABLE SCAN	<input type="checkbox"/>

Figure 138 View slave device details

Table 107 View slave devices details

Feature	Description
IN SCAN	<p>YES: scan is functioning for that device.</p> <p>NO: scan is not functioning for that device. Caused by one of the following:</p> <ul style="list-style-type: none"> PORT B STATUS is not GOOD. SCAN ENABLED is NO. COMM STATUS is NONE or BAD.
PORT B STATUS	<p>GOOD: Comm board is installed and functioning normally.</p> <p>NO BOARD: No comm board is present and the address is default 255. Download a configuration that uses the slave device.</p> <p>BOARD FAILURE: The comm board hardware has a serious failure. For example, the EEPROM failed when being written. In this condition, all communications on the Modbus link are ignored. Replace comm board.</p> <p>BOARD NOT FOUND: No comm board is installed and the address is non-default (1-254). Install comm board or set address to 255.</p>
SCAN ENABLED	<p>YES: Scan is enabled from ENABLE SCAN below.</p> <p>NO: Scan is disabled.</p>

Feature	Description
COMM STATUS	<p>GOOD: The slave is being scanned at the normal scan rate because its operation on the communication link is acceptable.</p> <p>NONE: Slave device is not defined in the control database. Download a configuration that includes the device.</p> <p>BAD: The slave device is being scanned at a slower rate because the slave device has experienced an abnormal number of failed responses. Perform these checks:</p> <ul style="list-style-type: none"> • If all slaves report BAD comm status, check the communication link connection to the master port. Ensure that the correct polarity is observed. If this is OK, check the connection to the first slave in the daisy-chain. • Check the communication link connection to the slave. Ensure that the correct polarity is observed. • Check that the slave is powered-up. • Check that the slave has the correct address. • Check that the slave has the correct baud rate.
MESSAGES RECEIVED	Number of messages received from this slave since the last cold start.
DATA LINK ERRORS	Number of data link errors for this slave since the last cold start. Data link error may be caused by line noise.
APPLICATION ERRORS	Number of application errors for this slave since the last cold start. Application error may be caused by trying to write to a read-only address.
ENABLE SCAN	Select this to enable scan for this slave. SCAN ENABLED should change to YES.

Bold items are read-only.

Communications Menu - Model 1041

For Model 551/552 - See Page 188

This menu lets you:

- view Comm A and B Status
- adjust communication ports COMM A and COMM B,
- view each slave device scan status and details.

COMMUNICATIONS		
	COMM A	COMM B
STATUS	REQUIRES SETUP	REQUIRES SETUP
MESSAGES RECEIVED	0	0
DATA LINK ERRORS	0	0
APPLICATION ERRORS	0	
COMM BOARD REV	3.10	
SET COMM A PORT		
STATION ADDRESS		255
BAUD RATE (BPS)		19200
PORT		DISABLE
DOUBLE REGISTER FORMAT		FPB
SET COMM B PORT		
BAUD RATE (BPS)		19200
SLAVE DEVICE		
VIEW STATUS		

Model 1041

Figure 139 Communications menu - Model 1041

Table 108 Communications menu details - Model 1041

Feature	Description
Comm A and Comm B STATUS	<p>ON LINE: Comm is on-line</p> <p>NO BOARD: No comm board is present and the address is default 255.</p> <p>REQUIRES SETUP: Comm board and the main CPU both have default addresses. Initialize the Modbus address.</p> <p>OFFLINE: Messages on the comm link are being ignored. Check Modbus settings and enable COMM A port.</p> <p>ONLINE: Messages on the comm link are being processed.</p> <p>BOARD FAILURE: The comm board hardware has a serious failure. For example, the EEPROM failed when being written. In this condition, all communications on the Modbus link are ignored. Replace comm board.</p> <p>BOARD NOT FOUND: No comm board is installed and the address is non-default (1-254). Install comm board or set address to 255.</p>
MESSAGES RECEIVED	Number of messages that were received and processed correctly.
DATA LINK ERRORS	Number of errors reported by the comm board.
APPLICATION ERRORS	Number of messages that were responded to with an exception error.
COMM BOARD REV	Firmware revision level on the controller comm board.

Feature	Description												
Set Comm Port A STATION ADDRESS	The address of the controller on the Modbus link. All devices on the link must have a unique address. The value is configurable from 1 to 247 and 255. 255 is the default address. If no communication board is installed, the default address should equal 255 to inhibit comm board diagnostics. If no communication board is installed and the default address is not 255, a diagnostic occurs.												
BAUD RATE	9600, 19200, 38400												
PORT	ENABLE: Enables the COMM A port. DISABLE: Disables COMM A port.												
DOUBLE REGISTER FORMAT (MODBUS)	Each IEEE 32-bit floating point number requires two consecutive registers (four bytes, MSB=4, LSB= 1 in byte order below) starting with the register defined as the starting register for the information. The stuffing order of the bytes into the two registers differs among Modbus hosts. To provide compatibility, the Double register format is configurable. Selections are: <table border="0" data-bbox="511 814 1356 1018"> <tr> <td>FPB</td> <td>Floating Point Big Endian Format</td> <td>Byte order – 4, 3, 2, 1 (DEFAULT)</td> </tr> <tr> <td>FP BB</td> <td>Floating Point Big Endian with byte-swapped</td> <td>Byte order – 3, 4, 1, 2</td> </tr> <tr> <td>FP L</td> <td>Floating Point Little Endian Format</td> <td>Byte order – 1, 2, 3, 4</td> </tr> <tr> <td>FP LB</td> <td>Floating Point Little Endian with byte-swapped</td> <td>Byte order – 2, 1, 4, 3</td> </tr> </table>	FPB	Floating Point Big Endian Format	Byte order – 4, 3, 2, 1 (DEFAULT)	FP BB	Floating Point Big Endian with byte-swapped	Byte order – 3, 4, 1, 2	FP L	Floating Point Little Endian Format	Byte order – 1, 2, 3, 4	FP LB	Floating Point Little Endian with byte-swapped	Byte order – 2, 1, 4, 3
FPB	Floating Point Big Endian Format	Byte order – 4, 3, 2, 1 (DEFAULT)											
FP BB	Floating Point Big Endian with byte-swapped	Byte order – 3, 4, 1, 2											
FP L	Floating Point Little Endian Format	Byte order – 1, 2, 3, 4											
FP LB	Floating Point Little Endian with byte-swapped	Byte order – 2, 1, 4, 3											
Set Comm Port B BAUD RATE	9600, 19200, 38400												
SLAVE DEVICE - VIEW STATUS	See Figure 137.												

Bold items are read-only.

File Name Selection

To expedite disk storage using DOS files, a list of file names may be created in advance. The operator selects from this list when naming profiles, recipes, and configurations about to be stored on the optional floppy disk.

This display lets you create and modify the list of 25 6-character file names.

FILE NAME SELECTIONS	
FILENAME1	CONFIG
FILENAME2	PROFIL
FILENAME3	RECIPE
FILENAME4	STORAG
FILENAME5	NAME5
FILENAME6	NAME6
FILENAME7	NAME7
FILENAME8	NAME8
FILENAME9	NAME9
FILENAME10	NAME10
FILENAME11	NAME11

Figure 140 File name selection

Table 109 File name selection details

Feature	Description
FILENAME _n	To modify a name, move the cursor to the name and press Enter. Next, use the Increment and Decrement keys to change each character in the six character name. Press Enter to keep the new name. Do not use backslashes\ or decimal places in file names. Use DOS compatible file names.

Self Tests

This function lets you perform tests to verify proper functioning of the Operator Interface.

Press Escape to end any test.

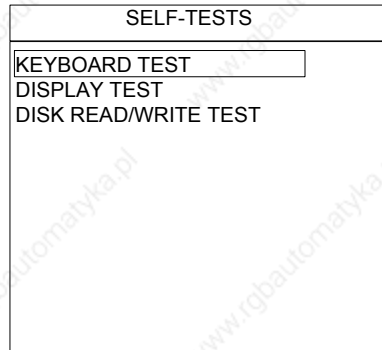

Figure 141 Self tests

Table 110 Self tests details

Feature	Description
KEYBOARD TEST	After selecting this, the display goes blank. Press any key to test that key—the key's name will appear if it is functioning properly. If the key's name does not appear, the key is faulty. The test can be run using the AT keyboard as well as the local keypad, but only the keys that are mapped to the keypad are exercised. See Table 3.
DISPLAY TEST	After selecting this, the display shows a spectrum of all possible 16 colors. If these colors are not shown, the display is faulty. Press Enter to cycle through the test displays.
DISK READ/WRITE TEST	<p>This tests the operation of the optional floppy disk drive then automatically formats the disk. NOTE: test is not performed on Zip drives.</p> <p>After selecting this, a prompt appears:</p> <p style="padding-left: 40px;">WARNING</p> <p style="padding-left: 40px;">THIS TEST WILL ERASE ALL EXISTING DISK FILES AND DATA.</p> <p style="padding-left: 40px;">PRESS ENTER TO BEGIN.</p> <p style="padding-left: 40px;">PRESS ESC TO ABORT.</p> <p>Make sure the disk in the drive does not contain valuable data. Press Enter to begin the test. After a few seconds, the display will indicate whether the test passed or failed. A failed test means the floppy drive is faulty, otherwise it is normal.</p> <p>Following the test a prompt allows the operator to re-format another disk.</p>

Calibrate AI

Analog Inputs are factory calibrated to 0.1% accuracy. For increased accuracy, Calibrate AI lets you

- change the controller mode from the menu to program or off-line,
- calibrate any analog input channel,
- calibrate cold junction temperature,
- copy calibration from one analog input channel to another or all channels,
- restore a channel's original factory calibration,
- restore a cold junction's factory calibration.

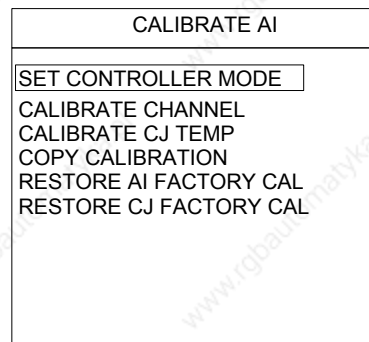

Figure 142 Calibrate AI



TIP

1. During calibration, the Controller must be in Offline or Program mode. Select "Set Controller Mode" from the menu and see Figure 143 for instructions.
 2. User calibration data (not factory calibration) is saved in Controller volatile memory.
 3. There is a cold junction compensation (CJC) calibration. Each Analog Input (AI) board has its CJC calibration performed at the factory, and this value is stored local to the AI board.
 4. The Controller (i.e., backplane, CPU board, AI & AO boards) is calibrated at the factory, and these values are stored local to the backplane.
 5. Each input can be calibrated individually (most accurate) or the calibration from an input can be copied to another (less accurate). This copy function will copy the calibration values to all inputs of the same type (e.g., across modules).
 6. The Field calibration values for each of the AI's are stored local to the CPU board.
 7. There is not a separate A/D calibration or module calibration. Consequently, if a module is changed then each of its inputs should be re-calibrated.
-

Set Controller Mode

When you select “Set Controller Mode” from the menu you can change the Controller’s operating mode. It has the same effect as if you changed the mode switch on the controller.

The current mode is indicated on the bottom right of the display.

Select OFF-LINE or PROGRAM in order to calibrate the AI.

If you press “ENTER ↵” while Set Mode is RUN the following warning appears:

THE CONTROLLER OUTPUTS ARE ACTIVE IN
THE RUN MODE, HELD IN OFF-LINE MODE,
AND DE-ENERGIZED IN PROGRAM MODE.

PRESS ENTER TO CHANGE
PRESS ESC TO ABORT.

Press ESC to return to “Calibrate AI” menu.

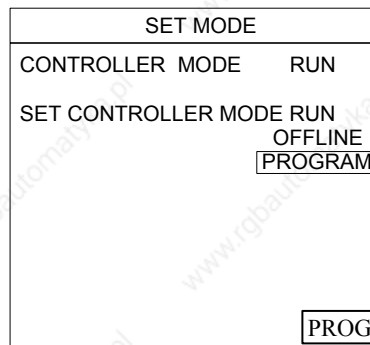

Figure 143 Set mode

Calibrate AI channel

This selection guides you through a procedure for calibrating an analog input channel. Perform the steps in the order of the menu. Refer to the example AI calibration procedure.



ATTENTION

If you are going to calibrate the cold junction temperature, do so before calibrating the AI. Cold junction calibration done after the AI calibration will cancel the AI calibration.

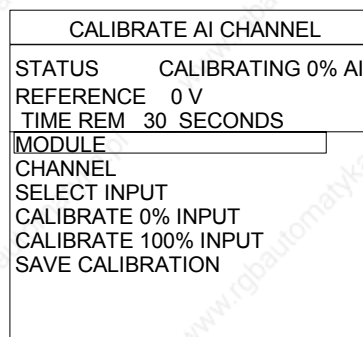

Figure 144 Calibrate AI channel

Table 111 Calibrate AI channel details

Feature	Description
STATUS	This displays the status at each step of calibration. In order of appearance: READY CONNECT 0% AI CALIBRATING 0% AI CONNECT 100% AI CALIBRATING 100% AI SAVE AI CALIBRATION AI CAL FAILED or DONE
REFERENCE	Indicates numeric input reference value and engineering units. Also indicates an invalid module or channel.
TIME REM	Time remaining until calibration is complete.
MODULE	Enter a Controller Module containing the AIs to be calibrated.
CHANNEL	Enter an AI channel to calibrate.
SELECT INPUT	Select this to verify that the displayed module and channel are correct.
CALIBRATE 0% INPUT	Connect 0% input to the AI terminals, then select this to calibrate. Calibration takes 30 seconds. Status will indicate when calibration is complete.
CALIBRATE 100% INPUT	Connect 100% input to the AI terminals, then select this to calibrate. Calibration takes 30 seconds. Status will indicate when calibration is complete.
SAVE CALIBRATION	Select this to save the channel calibration.

Bold items are read-only.



TIP

AI calibration fails when the difference of the 0 % entered value and the 100% entered value is less than 20 % of the input range.

Example of AI calibration

- AI channel to be calibrated must already be configured for the specific type input thermocouple.
- Procedure can be done via the Operator Interface or Utility software on a PC.
- This example assumes: Type T thermocouple, Range –328 to 752 Degrees F (as configured by the Control Builder software).
- This example assumes the calibration device is a direct temperature reading / compensated type. Therefore the specific type *TC extension wire* must be used between the calibrator and AI input.

Step	Action
1	Connect the calibrator via TC Extension Wire to the channel to be calibrated.
2	Put the controller into Program or Off-line mode.
3	Access CALIBRATE AI display.
4	Enter module (slot) & channel numbers. Go to CALIBRATE 100% INPUT then dial in 752 DegF on calibrator and follow prompts.
5	When the following is displayed: STATUS CONNECT 0% AI dial into calibrator : -328 DegF The REFERENCE value of –5.603 is mv's from IPTS tables (uncompensated). Ignore this reference value because calibrator in this example is compensated.
6	Save Calibration.
7	Place controller back into RUN mode.

Calibrate CJ temperature

This calibrates the cold junction temperature for any channel. Perform the steps in the order of the menu. Refer to the example CJ calibration procedure.

CALIBRATE CJ TEMP	
STATUS	CALIBRATING CJ
REFERENCE	22.510 DEGC
TIME REM	30 SECONDS
MODULE	1
CHANNEL	1
SELECT CJ INPUT	
CJ VALUE	25.100
CALIBRATE CJ INPUT	
SAVE CALIBRATION	

Figure 145 Calibrate CJ temp

Table 112 Calibrate CJ temp details

Feature	Description
STATUS	This displays the status at each step of calibration. In order of appearance: READY CONNECT CJ INPUT CALIBRATING CJ CJ CAL FAILED SAVE CJ CALIBRATION
REFERENCE	Indicates CJ temperature reading and engineering units. Also indicates an invalid module or channel.
TIME REM	Time remaining until calibration is complete.
MODULE	Enter a Controller Module containing the AIs to be calibrated.
CHANNEL	Enter an AI channel to calibrate.
SELECT CJ INPUT	Select this to verify that the displayed module and channel are correct.
CJ VALUE	Measure the temperature at the terminal block of the selected module and enter it here.
CALIBRATE CJ INPUT	Select this to start calibration. Calibration takes 30 seconds. Status will indicate when calibration is complete.
SAVE CALIBRATION	Select this to save the calibration.

Bold items are read-only.

Example of CJ Calibration

- CJ calibration is only for channels configured for TC inputs (not RTDs or voltage type inputs).
- A calibration source device is not required as is for AI calibrations.
- A device is needed to measure temperature at the screw terminals of channel being calibrated.

Step	Action
1	Put the controller into Program or Standby mode
2	Access CALIBRATE CJ display.
3	Enter Module (slot) and Channel numbers. Verify with SELECT CJ INPUT.
4	CJ VALUE requires an input number. This is the temperature as read with thermometer or other device at the screw terminals of CJ channel being calibrated. Enter in Degrees F or Degrees C matching the channel configuration.
5	Select CALIBRATE CJ INPUT and wait for the time out.
6	Select SAVE CALIBRATION.
7	Place controller in RUN mode.

Copy calibration

This copies calibration data from one channel to one or several channels. Perform the steps in the order of the menu.

COPY CALIBRATION	
STATUS	READY
REFERENCE	MA
FROM MODULE	1
FROM CHANNEL	1
TO MODULE	2
TO CHANNEL	3
COPY	

Figure 146 Copy calibration

Table 113 Copy calibration details

Feature	Description
STATUS	This displays the status of the copy. Possible statuses are: READY COPYING CALIBRATION COPY FAILED
REFERENCE	Indicates numeric input reference value and engineering units. Also indicates an invalid module or channel.
FROM MODULE	Enter Module number containing desired calibration.
FROM CHANNEL	Enter Channel number containing desired calibration.
TO MODULE	Enter Module number to be copied to.
TO CHANNEL	Enter Channel number to be copied to.
COPY	Select this to perform the copy.

Bold items are read-only.



TIP

1. To copy to a single channel: Enter "Module" number and "Channel" number.
2. To copy to all channels: Enter zero (0) for Module and zero (0) for Channel.
3. To copy to module: Enter "Module" number and zero (0) for "Channel".

Restore AI factory calibration

This restores the selected channel(s) to their factory calibration of 0.1% accuracy. Perform the steps in the order of the menu.

RESTORE AI FACTORY CAL	
STATUS	RESTORING AI CAL
REFERENCE	MA
MODULE	1
CHANNEL	1
RESTORE	<input type="text"/>

Figure 147 Restore AI factory calibration

Table 114 Restore AI factory calibration details

Feature	Description
STATUS	Displays the status of the restore. Possible statuses are: READY RESTORING AI CAL RESTORE AI FAILED
REFERENCE	Indicates numeric input reference value and engineering units. Also indicates an invalid module or channel.
MODULE	Enter the module to be restored.
CHANNEL	Enter the channel to be restored.
RESTORE	Select this to restore the channel.

Bold items are read-only.



TIP

1. To restore to a single channel: Enter "To Module" number and "To Channel" number.
2. To restore to all channels: Enter zero (0) for To Module and zero (0) for To Channel.
3. To restore to module: Enter "To Module" number and zero (0) for "To Channel".

Restore CJ factory calibration

This restores the cold junction to its factory calibration of 0.1 % accuracy. Perform the steps in the order of the menu.

RESTORE CJ FACTORY CAL	
STATUS	RESTORE I/P
REFERENCE	
MODULE	1
CHANNEL	1
RESTORE	<input type="text"/>

Figure 148 Restore CJ factory calibration

Table 115 Restore CJ factory calibration details

Feature	Description
STATUS	This shows the status of the restore. Possible statuses are: READY RESTORING CJ CAL RESTORE CJ FAILED
REFERENCE	Indicates numeric input reference value and engineering units. Also indicates an invalid module or channel.
MODULE	Enter the module containing the channel to be restored.
CHANNEL	Enter the channel to be restored.
RESTORE	Select this to restore calibration.

Bold items are read-only.

Calibrate AO

Analog Outputs are factory calibrated to 0.1 % accuracy. For increased accuracy, Calibrate AO lets you

- change the controller mode from this menu to Off-line or Program mode.
- calibrate any analog output channel
- restore an analog output channel's original factory calibration

Before calibrating an analog output, you must put the Controller in Program mode. Select “Set Controller Mode” from the menu and see Figure 143 for instructions.



Figure 149 Calibrate AO



TIP

Analog Output calibration data is saved on the AO board in the Controller; it is not saved in RAM as is Analog Input calibration. Therefore, AO calibration is not affected by a loss of power to the Controller.

Set Controller Mode

When you select “Set Controller Mode” from the menu you can change the Controller’s operating mode. It has the same effect as if you changed the mode switch on the controller.

The current mode is indicated on the bottom right of the display.

Select OFF-LINE or PROGRAM in order to calibrate the AO.

If you press “ENTER ↵” while Set Mode is RUN the following warning appears:

THE CONTROLLER OUTPUTS ARE ACTIVE IN
THE RUN MODE, HELD IN OFF-LINE MODE,
AND DE-ENERGIZED IN PROGRAM MODE.

PRESS ENTER TO CHANGE
PRESS ESC TO ABORT.

Press ESC to return to “Calibrate AO” menu.

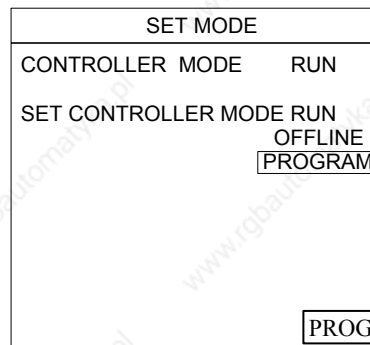

Figure 150 Set mode

Calibrate AO channel

This lets you calibrate any analog output channel. Perform the steps in the order of the menu.

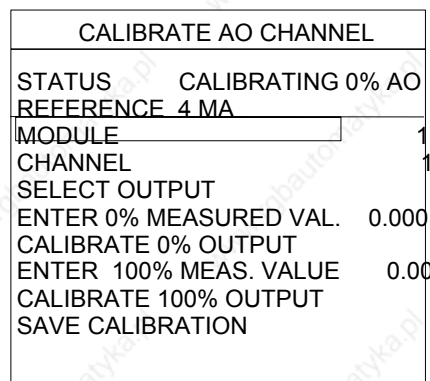

Figure 151 Calibrate AO channel

Table 116 Calibrate AO channel details

Feature	Description
STATUS	This shows the status of the calibration. In order of appearance statuses are: READY CONNECT 0% AO CALIBRATING 0% AO CONNECT 100% AO CALIBRATING 100% AO AO CAL FAILED SAVE AO CALIBRATION
REFERENCE	Indicates output reference value and engineering units. Also indicates an invalid module or channel.
MODULE	Enter a Controller Module containing the AOs to be calibrated.
CHANNEL	Enter an AO channel to calibrate.
SELECT OUTPUT	Select this to verify that the displayed module and channel are correct.
ENTER 0% MEASURED VAL.	Measure the actual output (as mA, mV or Volt) and then enter the measured value in mA here.
CALIBRATE 0% OUT	Select this to calibrate. Status will indicate when calibration is complete.
ENTER 100% MEAS. VALUE	Measure the actual output (as mA, mV or Volt) and then enter the measured value in mA here.
CALIBRATE 100% OUT	Select this to calibrate. Status will indicate when calibration is complete.
SAVE CALIBRATION	Select this to save the channel calibration.

Bold items are read-only.

**TIP**

1. The range of all Outputs is either 0-20 mA or 4-20 mA with an additional resistor for voltage outputs. However, the Controller software is not aware of the actual output; that is, volt, millivolt or milliamp. Consequently, it is your responsibility to know the resistor value if there is one.
2. AO calibration fails when the value entered by the user deviates from the forced output value by 1 % of the DAC range. For 4 mA dc, the value entered must be between 3.76 and 4.24 mA dc. For 20 mA dc, the value entered must be between 19.76 and 20.24 mA dc.

Restore AO factory calibration

This restores AOs to their factory calibration. Perform the steps in the order of the menu.

RESTORE AO FACTORY CAL	
STATUS	READY
REFERENCE	MA
MODULE	1
CHANNEL	1
RESTORE	

Figure 152 Restore AO factory calibration

Table 117 Restore AO factory calibration details

Feature	Description
STATUS	This shows the status of the calibration. In order of appearance statuses are: READY RESTORING AO CAL RESTORE AO FAILED
REFERENCE	Indicates output reference value and engineering units. Also indicates an invalid module or channel.
MODULE	Enter a Controller Module containing the AOs to be restored.
CHANNEL	Enter an AO channel to calibrate.
SELECT OUTPUT	Select this to verify that the displayed module and channel are correct.



TIP

1. To restore to a single channel: Enter "Module" number and "Channel" number.
2. To restore to all channels: Enter zero (0) for "Module" and zero (0) for "Channel".
3. To restore to module: Enter "Module" number and zero (0) for "Channel".

The Factory Calibration Gain values are one (1) and Offset values are zero (0) for all modules and channels.

Change display brightness - Model 1041 only

This display allows you to change the brightness on the display.

Press \triangle on the operator interface to **increase** the brightness

Press ∇ on the operator interface to **decrease** the brightness.

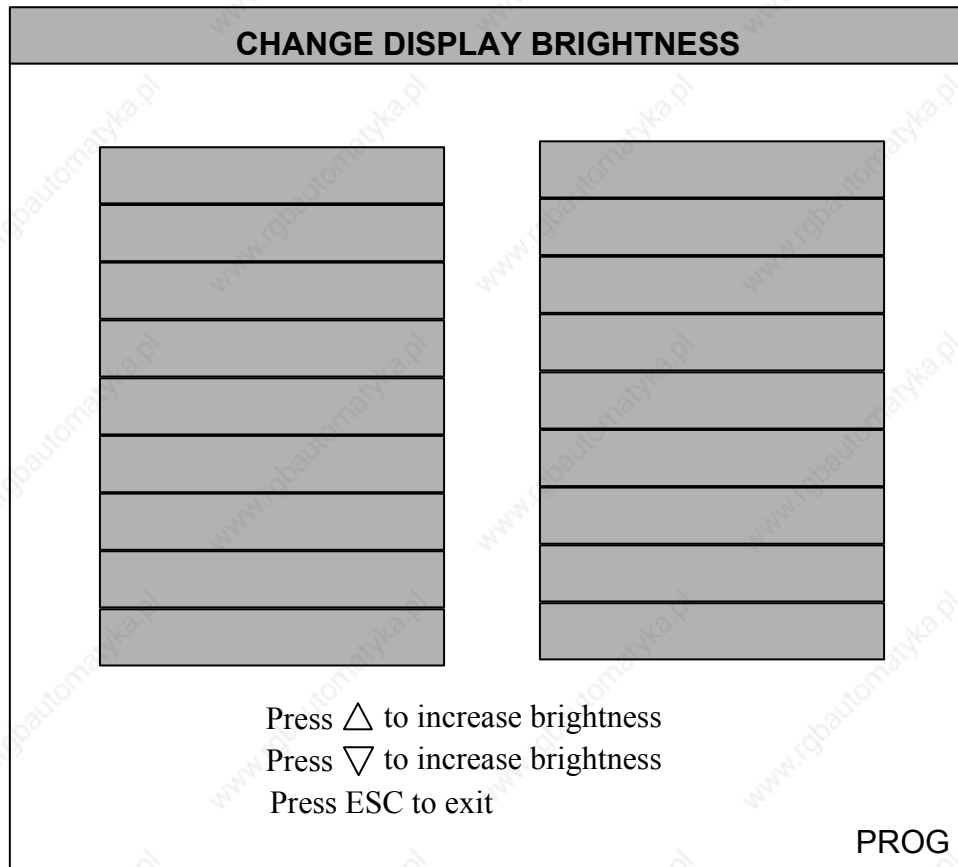

Figure 153 Brightness display

Parts

The following parts may be ordered. To order, see the contact information in the front of this manual.

Table 118 Parts

Part Number	Description
51404493-501	Membrane Keyboard
51309628-501	CPU Card
51404528-501	Display Assembly
51192597-501	Lamp Inverter
51404797-501	Cable Kit (contains the following): Disk Door Switch Keyboard Cable Display Cable Floppy Drive Cable Floppy Ribbon Cable Lamp Inverter Cable (2)
51404523-501	10' Cable (for 551, 552, and 1041)
51404523-502	50' Cable (for 551, 552, and 1041)
31404524-501	Mounting Kit
51404610-501	Replacement Display Lamp
51404557-501	Disk Drive Kit
51404600-501	RS485 Terminal board
51404551-501	Bezel and Case Assembly
51404951-501	Data Storage option firmware Requires Revision Level 2. To learn your instrument's revision level, see <i>Controller Status (page 180)</i> .
51404951-502	Data Storage option firmware Requires Revision Level 3. To learn your instrument's revision level, see <i>Controller Status (page 180)</i> .
047260	Noise filtering for CE compliance [see <i>Installing Ferrite Clamp for CE Compliance (page 16)</i>]: Ferrite cable clamp
089037	Cable ties
For Model 1041 only	
51500678-501	Membrane Switch Assembly
51500616-501	CPU Assembly
51451629-001	Upgrade Floppy Disk

Part Number	Description
51451630-001	Upgrade ZIP Disk
51404524-501	Hardware Mounting Kit
51451582-001	Gasket Kit
51451583-001	Floppy Disk Kit
51500584-001	ZIP Drive Kit
51404525-502	Disk Switch Assembly
51451584-001	Replacement Display Lamp Assembly
51404764-501	Display Assembly

Messages

Overview

The Operator Interface displays messages that guide, advise, and warn the operator.

Table 119 shows all messages, the function in which the message appears, and a description along with any recommended action.

Table 119 Messages

Message	Function	Description/Action Recommended
...FORMATTING DISK...	Format Disk	Disk formatting is in progress.
...INITIALIZING DISK...	Data Storage disk initialization	The function is in progress.
...TEST IN PROGRSS...	Disk Read/Write Self-Test	The test is in progress.
AED REPORT FAIL	Status line	<ol style="list-style-type: none"> 1. Cycle Operator Interface power off and on. 2. Reload configuration. 3. If message recurs, replace CPU.
BEGINNING OF BUFFER	Scrolling Trends	The beginning of the trend data buffer was reached
BEZEL OPEN	Status line	The door on the OI that protects the disk drive is currently open. Data will not be read from or written to the diskette while this door is open.
CHECKING DISK	Status line	The OI is currently validating the diskette that was just inserted.
CONTROLLER DIAG	Status line	The controller file has posted a diagnostic.
DB ALLOC ERROR	Status line and Panel Diagnostic Log	<ol style="list-style-type: none"> 1. Do an Operator Cold Start as described on page 17 2. Call the O/I vendor for assistance.
DB RECORD ERROR	Status line and Panel Diagnostic Log	<ol style="list-style-type: none"> 1. Do an Operator Cold Start as described on page 17 2. Verify that the firmware versions of the operator interface and the controller are compatible 3. Call the O/I vendor for assistance

Message	Function	Description/Action Recommended
DB VERIFY ERROR	Status line and Panel Diagnostic Log	<ol style="list-style-type: none"> 1. Do an Operator Cold Start as described on page 17 2. Verify that the firmware versions of the operator interface and the controller are compatible 3. Verify that there are no loose wires in the cable that connects the operator interface and the controller 4. Call the O/I vendor for assistance <p>If the O/I reports this diagnostic, the following conditions may also be present:</p> <ol style="list-style-type: none"> 1. The alarm help message on the alarm detail display will show "?????" if help text was set for that alarm 2. The 16-character signal descriptor will default to the 8-character signal tag 3. Operator Interface security is turned off 4. The parameter "Frequency" will show a value of "Error" on the controller status display.
DISK ERROR	Status line	An error was encountered accessing the diskette. The diskette may be bad or the interface to the disk drive is not functional.
DISK FULL	Store configuration/ recipe/profile/ schedule to disk	No more space is available on one or more of the files on the floppy disk for storage of data as programmed. Each diskette has a maximum of 224 files per diskette, so a new diskette must be used. This message will appear only if at least one partition on the disk is programmed for non-rollover operation. The message will disappear when a new disk is initialized, or if data storage is disabled (turned off).
DISK MISSING	Status line	Data storage is enabled, but no disk is installed in the disk drive.
DISK WARNING	Status line	Floppy disk is not full but available space on one or more disk files has reached the programmed warning limit. The message will disappear when a new disk is initialized, or if data storage is disabled (turned off).
DS INIT FAILED	Status line	Initialization failed. Possible reasons: disk has not been formatted, is write-protected, or is defective.
DS STATUS LOST	Status line	<ol style="list-style-type: none"> 1. Check for bad floppy disk. 2. Run disk diagnostic on the disk drive. 3. Check seating of floppy cables. 4. Replace CPU.

Message	Function	Description/Action Recommended
DSK NOT CURRENT	Status line	When a disk is initialized the instrument marks it as the “current” disk. The instrument will only store data to the “current” disk. If any other disk is placed in the drive this message will appear. The message will disappear when the “current” disk is inserted or a new disk is initialized.
EDITS NOT ALLOWED IN THIS STATE	Edit Program Edit Segment Edit Segment Events	The controller will not accept edits to a program with the associated programmer in its current state.
END OF BUFFER	Scrolling Trends	The end of the trend data buffer was reached
ERROR – EDITS NOT SAVED	Edit Recipe Edit Program	A write transaction to the controller failed.
ERROR ENABLE SCAN FAILED. PRESS ESC TO EXIT	Communications: View Slave Details	Communications failure during scan enable. Escape and retry.
ERROR – READ FAILED	Edit Recipe Edit Program	A read transaction to the controller failed.
FORMAT COMPLETE	Format Disk	Disk formatting successfully completed.
GENERAL ERROR		This message will appear if the instrument encounters any error not listed above.
HANDSHAKE FAIL	Status line	<ol style="list-style-type: none"> 1. Cycle Operator Interface power off and on. 2. Reload configuration. 3. If message recurs, replace CPU.
INITIALIZATION COMPLETE	Data Storage disk initialization	The function successfully completed.
INITIALIZATION FAILED BEZEL OPEN	Data Storage disk initialization	The requested disk operation failed because the front bezel was opened.
INITIALIZATION FAILED DEVICE ERROR	Data Storage disk initialization	The requested disk operation failed because the disk, the drive, or the drive interface is faulty.
INITIALIZATION FAILED WRITE PROTECTED	Data Storage disk initialization	The requested disk operation failed because the disk was write protected..
INITIALIZING DSK	Status line	The OI is initializing the data storage disk for the current data storage set.
LOAD COMPLETE	Load file from disk	The function successfully completed.
LOAD/STORE LOCKED BY PC HOST	Load/store controller configuration from/to disk	User attempts to load or store configuration data while a configuration file is being downloaded via the PC over another comm. port. The message will continue to appear until the controller has been cold-started following the PC download. Wait until the PC download has completed, and then restart the load/store from the Operator Interface menu.

Message	Function	Description/Action Recommended
LOADING CONFIG... xx% ..WAIT..	Load controller configuration from disk	The function is in progress.
LOADING PROFILE...	Load Profile from disk	The function is in progress.
LOADING RECIPE...	Load Recipe from disk	The function is in progress.
LOADING SCHEDULE...	Load Schedule from disk	The function is in progress.
LOADING STORAGE SET...	Load data storage set from disk	The function is in progress.
MUST BE IN PROGRAM MODE	Load configuration	Must be in Program mode to load configuration.
MUST BE IN PROGRAM MODE OR OFFLINE MODE	Calibrate AI Calibrate AO	The controller will not perform the function in the current controller mode.
OI COMMUNICATION FAILURE THE OPERATOR STATION CANNOT COMMUNICATE WITH THE CONTROLLER FILE. PLEASE CHECK THE CABLE WHICH CONNECTS THE OPER. STATION AND THE CONTROLLER FILE.	Startup of OI	Check cable.
OP ENTRY FAILED	Status line	The request to write data from the OI to the controller failed.
OPERATION FAILED LOAD FAILED VERSION x TABLE y	Disk operation	Configuration load failed. Retry function. If message recurs, write down message along with version and table numbers and contact Honeywell technical support.
OPERATION FAILED STORE FAILED VERSION x TABLE y	Disk operation	Configuration store failed. Retry function. If message recurs, write down message along with version and table numbers and contact Honeywell technical support.
OPERATION FAILED NOT ALLOWED IN RUN MODE	Load .DSS or .FBD file from disk	The function requires the controller to be in PROGRAM mode.
OPERATION FAILED BEZEL OPEN	Disk operation	The requested disk operation failed because the front bezel was opened.
OPERATION FAILED COMMUNICATIONS ERROR VERSION x TABLE y	Load controller configuration from disk	Communications between the Operator Interface and the controller failed during the operation. Retry function. If message recurs, write down message along with version and table numbers and contact Honeywell technical support.
OPERATION FAILED DEVICE ERROR	Disk operation	The requested disk operation failed because the disk, the drive, or the drive interface is faulty.

Message	Function	Description/Action Recommended
OPERATION FAILED ERROR IN FILE RECORD DATA VERSION x TABLE y	Load controller configuration from disk	The file content check failed. Retry function. If message recurs, write down message along with version and table numbers and contact Honeywell technical support.
OPERATION FAILED FILE VERIFY FAILED VERSION x TABLE y	Load controller configuration from disk	The file failed the data integrity check. Retry function. If message recurs, write down message along with version and table numbers and contact Honeywell technical support.
OPERATION FAILED FILE VERSION IS INCORRECT VERSION x TABLE y	Load controller configuration from disk	The file version is incompatible with the controller. Retry function. If message recurs, write down message along with version and table numbers and contact Honeywell technical support.
OPERATION FAILED MUST BE IN PROGRAM MODE VERSION x TABLE y	Load controller configuration from disk	The function requires the controller to be in PROGRAM mode. Retry function. If message recurs, write down message along with version and table numbers and contact Honeywell technical support.
OPERATION FAILED UNEXPECTED END OF FILE VERSION x TABLE y	Load controller configuration from disk	The end of file mark was encountered before it was expected. Retry function. If message recurs, write down message along with version and table numbers and contact Honeywell technical support.
OPERATION FAILED WRITE PROTECTED	Disk operation	The requested disk operation failed because the disk was write protected.
PRESS ENTER TO SAVE CHANGES	Setting time and date	Pressing enter will write the data to the controller. Pressing escape will leave without writing the data to the controller.
PROCESSOR EXCEP	Status line	<ol style="list-style-type: none"> 1. Cycle Operator Interface power off and on. 2. Reload configuration. 3. If message recurs, replace CPU.
PROCESSOR RESET	Status line	<ol style="list-style-type: none"> 1. Cycle Operator Interface power off and on. 2. Reload configuration. 3. If message recurs, replace CPU.
QUEUE READ FAIL	Status line	<ol style="list-style-type: none"> 1. Cycle Operator Interface power off and on. 2. Reload configuration. 3. If message recurs, replace CPU.
REQUEST FAIL	Status line	<ol style="list-style-type: none"> 1. Cycle Operator Interface power off and on. 2. Reload configuration. 3. If message recurs, replace CPU.
RESPONSE FAIL	Status line	<ol style="list-style-type: none"> 1. Cycle Operator Interface power off and on. 2. Reload configuration. 3. If message recurs, replace CPU.

Message	Function	Description/Action Recommended
SET TIME AND DATE	Data Storage Disk Initialization	Go to the Unit Setup display and set the date to the present year. Data storage cannot be started if the date is less than Jan1, 1980.
STORAGE FAILURE	Status line	<ol style="list-style-type: none"> 1. Check for bad floppy disk. 2. Run disk diagnostic on the disk drive. 3. Check seating of floppy cables. 4. Replace CPU.
STORAGE FULL	Status line	<p>The data storage RAM buffer is full. Data is accumulating in the internal buffer (temporary storage) because it is unable to store the data on the floppy disk. Possible reasons include:</p> <ul style="list-style-type: none"> • Disk is full and storage is programmed as non-rollover. • There is no disk in the drive. • The disk is write-protected. • The operator is in the process of retrieving stored data from the disk. • The disk is “not current” (see DSK NOT CURRENT). • The front bezel is open. <p>The message will disappear when the condition is corrected, or if data storage is disabled (turned off).</p>
STORE COMPLETE	Store file to disk	The function successfully completed.
STORING CONFIG... xx% ...WAIT...	Store controller configuration to disk	The function is in progress.
STORING PROFILE...	Store Profile to disk	The function is in progress.
STORING RECIPE...	Store Recipe to disk	The function is in progress.
STORING SCHEDULE...	Store Schedule to disk	The function is in progress.
STORING STORAGE SET...	Store data storage set to disk	The function is in progress.
TASK ERROR	Status line	A software function (task) on the OI encountered a non-recoverable error.
TASK INIT FAIL	Status line	A software function (task) on the OI failed in its start-up initialization..
TEST COMPLETE	Disk Read/Write Self-Test	The test successfully completed.

Message	Function	Description/Action Recommended
TEST FAILED	Disk Read/Write Self-Test	The test failed.
UPDATING DISK	Status line	Storage data is being written from RAM to the storage diskette.
WAIT...	Edit Recipe Set Security	A write transaction with the controller is in progress.
WAIT... READING DATA	Select Recipe	A read transaction with the controller is in progress.
WARNING FILENAME ALREADY EXISTS PRESS ENTER TO OVERWRITE PRESS ESC TO ABORT	Store file to disk	The selected file name already exists on the disk. Continuing will overwrite the file found on the disk.
WARNING INITIALIZATION WILL ERASE ALL EXISTING DISK FILES AND DATA PRESS ENTER TO INIT PRESS ESC TO ABORT	Data Storage disk initialization	Continuing will erase all data from the disk and initialize the disk for the current storage set.
WARNING THE CONTROLLER OUTPUTS ARE ACTIVE IN RUN MODE, HELD IN OFFLINE MODE AND DE-ENERGIZED IN PROGRAM MODE.	Setting controller mode	Changing the controller mode can result in its physical outputs being activated (RUN) or disabled (OFFLINE or PROGRAM).
WARNING THIS TEST WILL ERASE ALL EXISTING DISK FILES AND DATA PRESS ENTER TO BEGIN PRESS ESC TO ABORT	Disk Read/Write Self-Test	Continuing will erase all data from the disk and result in an unformatted disk.
WARNING THIS TIME CHANGE WILL ERASE TREND DISPLAY DATA AND FLUSH STORAGE DATA TO DISK PRESS ENTER TO SAVE PRESS MENU TO ABORT	Setting time and date back	Proceeding to set the time/date backward will result in the trend data being overwritten with new data. It will also force storage buffers to be written to disk and the storage disk to be closed out (marked full).
WARNING THIS UTILITY WILL ERASE ALL EXISTING DISK FILES AND DATA PRESS ENTER TO BEGIN PRESS ESC TO ABORT	Format Disk	Continuing will erase the contents of the disk.
WARNING THIS UTILITY WILL OVERWRITE THE EXISTING CONTROLLER CONFIG. PRESS ENTER TO LOAD PRESS ESC TO ABORT	Load controller configuration from disk	Continuing will overwrite the configuration currently loaded in the controller.
WARNING THIS UTILITY WILL OVERWRITE THE EXISTING STORAGE SETTING. PRESS ENTER TO LOAD PRESS ESC TO ABORT	Load data storage set from disk	Continuing will overwrite the data storage set currently loaded in the controller.

Message	Function	Description/Action Recommended
WARNING THE CONTROLLER OUTPUTS ARE ACTIVE IN THE RUN MODE, HELD IN OFF-LINE MODE, AND DE-ENERGIZED IN PROGRAM MODE.	Calibrate AI and AO	Change program mode to Off-line or Program
WRITE-PROTECTED	Disk Operation	The disk in the drive has its write-protected tab set to the protect position.
WRITE-PROTECTED	Status line	The diskette is not enabled for write operations.

Appendix

Extending Distance from Operator Interface to Controller

The standard wiring options for the Operator Interface limit the distance between the controller and interface to no greater than 50 feet. This limitation results from the power supply leads included in the communication cable that provide power to the interface and the need to maintain ground potentials between the controller and interface to less than the maximums specified for RS 485 communications.

The use of an external communication link isolator and a separate 24 Vdc power supply for the OI will now allow distances between the controller and operator to extend to up to 2000 feet.

To implement this capability, the following items are recommended:

- RS422/485 Isolator
 - Purchase from:
 - B&B Electronics Manufacturing Co.
 - Model 485OP
 - List price: \$129
 - www.bb-elec.com
 - (815)-433-5100
- Resistors (4), 120 ohm
- Power Supply with the following attributes:
 - 24 Vdc Power, (1.3A) \pm 10 %
- Communication Cable:
 - 2 twisted pair with shield
 - Belden 8728 or equivalent
 - Honeywell PN 837052

Connect the above items according to Figure 154.

CONTROLLER CONNECTOR
 (all shields are connected to the shell)

- (+24V) {BLACK} 1
- (+24V) {BLUE} 2
- (Sig Gnd.) {BLACK} 3
- (Sig Gnd.) {GREEN} 4
- (TXb+) 5
- (RXa-) {BLACK} 6
- (RXa+) {RED} 7
- (TXa-) {BLACK} 8
- (+24V) 9
- (Sig Gnd.) 10
- (Sig Gnd.) 11
- (RXb-) 12
- (TXa+) {WHITE} 13
- (TXb-) 14
- (RXb+) 15

485 Isolator Long Side

- Data in -
- Data in +
- Data out +
- Data out-
- Sig. Gnd
- Prot.Gnd
- +12 Gnd
- +12 V

485 Isolator Short Side

- Data Out -
- Data Out +
- Data In -
- Data In +
- Sig. Gnd
- Prot.Gnd

OPERATOR INTERFACE TERMINALS

551/1041

- 1 (RX-) {BLACK}
- 2 (RX+) {WHITE}
- 3 (Com. Shields.) {Bare Drain}
- 4 (TX-) {BLACK}
- 5 (TX+) {RED}
- 6 (Sig Gnd.) {BLACK & GREEN}
- 7 (Chassis) {Bare Drain}
- 8 (Chassis)
- 9 (+24V) {BLACK}
- 10 (+24V) {BLUE}

552

- 10 (+24V) {BLUE}
- 9 (+24V) {BLACK}
- 8 (Chassis)
- 7 (Chassis) {Bare Drain}
- 6 (Sig Gnd.) {BLACK & GREEN}
- 5 (TX+) {RED}
- 4 (TX-) {BLACK}
- 3 (Com. Shields.) {Bare Drain}
- 2 (RX+) {WHITE}
- 1 (RX-) {BLACK}

485 to 485 Isolator (SHOWN)
 B&B Electronics
 Manuf. Co.
 Model 485OP
 www.bb-elec.com
 (815)-433-5100

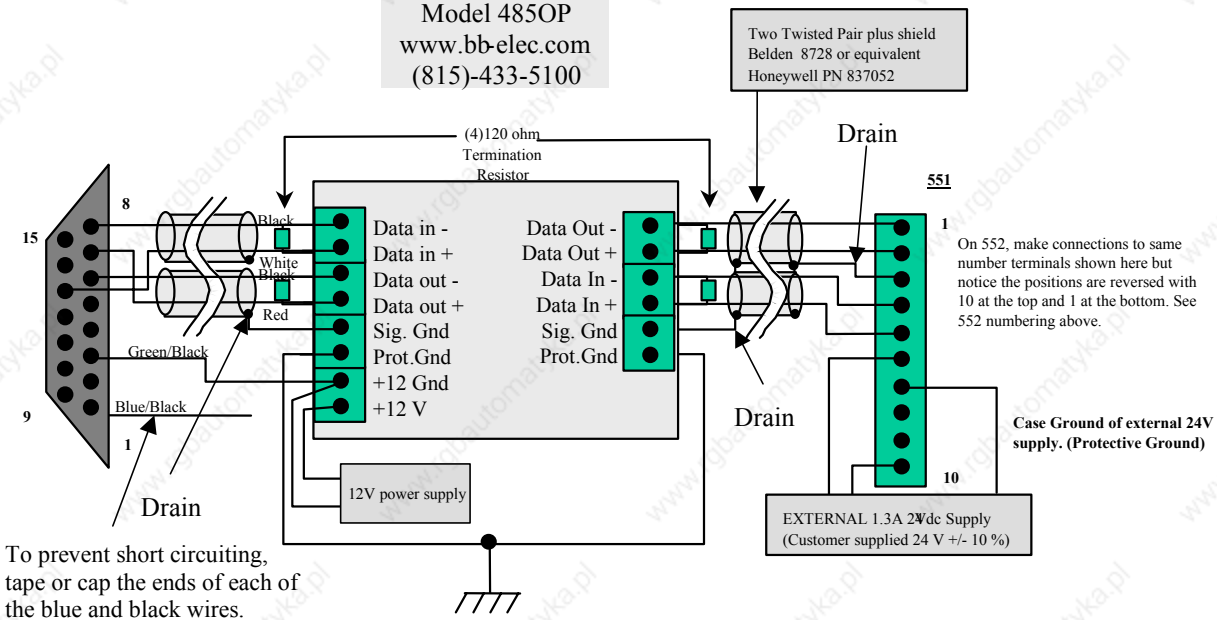

NOTE: Isolators timing jumpers (JP2 & JP4) must be set in position "E" (38.4kB)

Figure 154 Remote operator interface connection

Security Bypass Procedure

Overview

Your instrument has a security bypass code which allows you to enter secured areas of the product. Use this bypass code if you have forgotten or lost the Engineer and/or Operator security code.

Bypass procedure

Step	Action
1	When you are prompted for the engineer or operator security code, use Increment and Decrement keys to select the bypass code 783.
2	With 783 displayed, press the Display 5 key (under the display) to display the forgotten engineer or operator code.
3	To return to the previous menu without entering the secured area, press Escape. To enter the secured area, press Enter.



ATTENTION

Remove this page for security.

Index

—A—

- Alarm
 - acknowledge, 139
 - analog, 135
 - detail, 44, 140
 - discrete, 135
 - indication, 136
 - investigating, 136
 - latching, 136
 - loop, 136
 - types, 136
- Alarm Group, 43, 139
- Alarm Summary, 43, 137
- Alarms/Events/Diagnostics, 43
 - Alarm Detail, 44
 - Alarm Group, 43
 - Alarm Summary, 43
 - Clear Diag Stripe, 51
 - Controller Diagnostics, 45
 - Event Summary, 44
 - Panel Diagnostic Log, 50
- architecture
 - components, 3
- AT keyboard, 19, 20, 21
- Auto/Manual
 - switching loop mode, 23
- auto/manual bias, 91
- Autotuning Output Low Limit Value, 78

—B—

- Bar Graph, 154
- bias
 - auto/manual, 91
 - ratio, 73

—C—

- Cable connections, 14
- Calibration
 - analog input, 200
 - analog output, 209
 - cold junction, 204
 - copy, 206
 - restore to AI factory, 207
 - restore to AO initial, 212
 - restore to CJ factory, 208
- Carbon loop, 75
- Cold Start
 - defined, 64, 181
- Communications
 - COMM A port status, 189
 - COMM B port status, 191
 - Set COMM A port, 190
 - Set COMM B port, 192
 - View Slave Details, 194

- View Slave Devices, 193
- Configuration
 - load, 61
 - store, 62
- Controller Diagnostics, 45
- Controller status, 180
- Custom keys
 - relabeling, 29

—D—

- Data storage
 - calculate disk capacity, 162
 - controls, 173
 - enabling, 167
 - file name conventions, 174
 - initialize, 174
 - intervals, 165
 - load settings, 175
 - modes, 165
 - operation, 170
 - overview, 161
 - start new storage settings, 177
 - store settings, 178
 - view settings, 176
 - view status, 171
- Date
 - setting, 182
- Diagnostic
 - clear stripe, 51
 - controller, 45
 - I/O, 49
 - panel log, 50
- Diagnostic stripe
 - clear, 51
- Disk
 - format, 63
- Disk File
 - list, 54
- Disk Files
 - data storage naming convention, 174
 - naming conventions, 54
- Disk Utilities, 53

—E—

- Escape, 24
- Event
 - summary, 44
- Events
 - Setpoint program. *See* Setpoint program
 - Setpoint schedule. *See* Setpoint schedule

—F—

- F1-F4 buttons, 141, 142, 143
- File Name Selection, 198
- Files

customizing available filenames, 198
firmware
 revision number, 66
Floating Point Big Endian, 190, 197
Floating Point Little Endian, 190, 197
Format Disk, 63
Four Selector Switch, 142, 143

—H—

H indicator, 32
Help, 159

—I—

I/O Diagnostics, 49
Ignore changes to a number
 how to, 24

—K—

Keys
 Tasks using standard keys, 23

—L—

Language
 set displays, 187
log off/log on, 66
Loop
 1 loop numeric, 87
 2 loop faceplate, 86
 3 loop faceplate, 85
 4 loop faceplate, 83, 84
 alarm setpoints, 76
 auto/manual bias, 91
 autotune, 71
 carbon, 75
 control, 82
 control setup, 73
 limits, 78
 Menu, 69
 modes, 67, 79
 setup, 68
 trend, 70
 tune constants, 72
Loop capacity, 180
Loop output
 changing, 23
Loops, 42

—M—

Main menu, 39
Maintenance, 179
Messages from system, 217
Mode
 setting, 64, 181
Mounting, 7

—O—

Operator Interface
 extending distance from controller, 225
Overview display, 158

—P—

Panel display
 interacting with, 155

meter, 157
multi-point, 156, 157
single, 155
part number
 of operator interface, 66
parts
 replacement, 214
Profile
 load/store, 55
Pushbuttons, 141

—R—

Recipe
 load, 41, 147
 load/store, 59
Recipe, 40
Recipe load, 147
replacement parts, 214
revision number
 firmware, 66

—S—

S indicator, 32
Scheduler, 42
Securing access. *See* Security
Security, 183
 how to access secured area, 184
setpoint
 switch, 73
Setpoint
 switch, 82, 89
Setpoint program
 auxiliary start value, 111
 clear program, 105, 108
 edit, 95
 edit segment events, 99
 edit segments, 97, 105, 108, 111
 elapsed time, 108
 fast forward, 96
 load, 106
 operate menu, 108
 overview, 93
 popup menu, 108
 PV#2 through PV#4, 108
 save, 99, 105, 108
 setup, 94
 single SPP operation, 102
 states, 102, 104
 states vs. actions, 109
 time remaining, 108
 view details, 110
 view events, 108, 109
Setpoint schedule
 clear from scheduler, 130
 defined, 113
 edit, 115
 edit guarantee hold, 119
 edit guarantee hold limits, 121
 edit segment events, 118
 edit segments, 116, 130, 134
 edit setpoints, 117, 134

- load, 128
- load from disk, 57
- operate menu, 130
- operation, 124, 126
- overview, 113
- popup menu, 130
- save, 120, 130
- setup, 114
- states**, 124, 126
- states vs. actions, 131
- store to disk, 57
- view auxiliary setpoints, 130
- view details, 133
- view events, 130, 132
- Site preparation, 7
- SP Programmers, 41
- SP Scheduler, 42
- Specifications, 5
- Standard Keys
 - names and functions, 21
- status line, 31
- T—**
- Testing
 - display, 199
 - floppy disk, 199
- keypad, 199
- Time
 - setting, 182
- Trend, 150
 - detail, 152
 - hold, 152
 - Popup menu, 152
 - scroll, 152
 - scrolling, 26
 - zoom, 152
- U—**
- Unit Setup, 52, 179
- V—**
- Variables
 - view, 51
- View Variables, 51
- W—**
- Warm Start
 - defined, 64, 181
- Z—**
- Z indicator, 32



For at undgå elektrisk stød med mulighed for personskade, skal alle sikkerhedsbestemmelser i denne manual følges nøje.



Dette symbol advarer brugeren om en potentiel berøringsfare, såfremt der kan være adgang til den livsfarlige netspænding.



Beskyttende jordterminal. Terminalen er forberedt for og skal forbindes til beskyttelsesjordledning i henhold til stærkstrømsberkendtgørelsen (DK).

- Hvis udstyret ikke bruges som specificeret i manualen, kan den beskyttelse udstyret yder blive nedsat eller forsvinde.
- Erstat kun komponenter som udtrykkeligt er specificeret som udskiftelige i manualen.
- Alle ledningsforbindelser skal følge stærkstrømsberkendtgørelsen (DK) og udføres af autoriseret erfarent personel.
- Den beskyttende jordterminal skal forbindes først af alle forbindelser (og fjernes som den sidste).
- Det anbefales jvf. stærkstrømsberkendtgørelsen, at der installeres en afbryder til frosningsspændingen nær udstyret.

UDSTYRS SPECIFIKATIONER

Strømforsyning	100 til 240 V
Frekvens	50 – 60 Hz
Nominel effekt	100 VA

OMGIVELSE SPECIFIKATIONER

Placer ikke udstyret i nærheden af brandbare væsker eller dampe.

Temperatur	Rumtemperatur : 15 til 55°C
Fugtighed	10 til 90% RH - 40°C
Vibration	14 til 250 Hz acceleration 1 g

UDSTYRS INSTALLATION

Skrivervaren skal monteres i en tavle for at forhindre adgang til bagterminaler.



Ter vermindering van het gevaar van elektrische schokken die lichamelijk letsel kunnen veroorzaken, dient u alle veiligheidsaanwijzingen in dit document te volgen.



Dit symbool waarschuwt de gebruiker voor een potentieel schokgevaar wanneer toegang bestaat tot onderdelen die onder gevaarlijke spanning staan.



Beschermende aarde-aansluiting. Bestemd voor aansluiting van de aardingsdraad van de voeding.

- Indien de apparatuur wordt gebruikt anders dan door de fabrikant gespecificeerd, kan de bescherming, die de apparatuur biedt ongedaan worden gemaakt.
- Alleen die onderdelen mogen worden vervangen die door de fabrikant als uitwisselbaar zijn aangemerkt.
- Alle bedrading moet in overeenstemming zijn met de lokale elektriciteiseisen en moet aangelegd worden door geautoriseerd, ervaren personeel.
- De aardingsdraad moet worden aangesloten vóórdát alle andere bedrading wordt aangesloten (en als laatste worden verbroken).
- Het verdient aanbeveling een netschakelaar aan te brengen vlakbij het instrument.

APPARATUUR VOORWAARDEN

Voedingsspanning	100 tot 240 V
Frequentie	50 – 60 Hz
Vermogen of stroomvermogen	100 VA

OMGEVINGSCONDITIES

Gebruik het instrument niet in de aanwezigheid van ontvlambare vloeistoffen of dampen. Het gebruik van elk elektrisch instrument in een dergelijke omgeving vormt een gevaar voor uw veiligheid.

Temperatuur	In bedrijf : 15 tot 55°C
Vochtigheid	10 tot 90% RH - 40°C
Trilling	14 tot 250 Hz versnelling 1 g

MONTAGE VAN DE APPARATUUR

De recorder moet worden gemonteerd in een paneel om de toegankelijkheid tot de achterste aansluitpunten te beperken.

TURVALLISUUSMÄÄRÄYKSET

FI2I-6048



Noudata tämän ohjeen kaikkia turvaohjeita välttääksesi sähkötapaturman vaaraa.



Tämä merkki varoittaa käyttäjää sähköiskun vaarasta paikassa, missä voi koskettaa vaarallisia jännitteitä.



Suojamaaliitin. Kytke maadoitsjohdin tähän liittimeen.

- Jos laitetta käytetään olosuhteissa, joihin sitä ei ole suunniteltu, käyttöturvallisuus voi heikentyä.
- Älä vaihda mitään komponenttia tai osaa, jota valmistaja ei ole määritellyt käyttäjän vaihdettavaksi.
- Asennus ja johdotus on tehtävä paikallisten varmuusmääräysten mukaisesti valtuutetun sähköasentajan toimesta.
- Ensimmäiseksi on kytkettävä suojamaa-liitin (ja viimeiseksi irroitettava).
- Laitteen läheisyyteen suositellaan asennettavaksi verkkokytin.

LAITTEEN VAATIMUKSET

Syöttöjännite	100 - 240 V
Taajuus	50 – 60 Hz
Teho	100 VA

KÄYTTÖOLOSUHTEET

Älä käytä laitetta paikassa jossa on syttyviä nesteitä tai kaasuja, koska laitteen käyttö aiheuttaa räjähdysvaaran.

Lämpötila	ympäröivä : 15 ... 55°C
Kosteus	10 ... 90% RH - 40°C
Tärinä	14 ... 250 Hz
	Kiihtyvyys 1 g

LAITTEEN ASENNUS

Piirturi on asennettava paneeliin siten, että peräliitimille jää riittävästi tilaa.

CONSIGNES DE SECURITE

FR2I-6048



Pour réduire tout risque de décharge électrique qui pourrait provoquer une lésion corporelle, respectez toutes les consignes de sécurité de cette documentation.



Ce symbole avertit l'utilisateur d'un risque électrique potentiel lorsqu'il peut avoir accès à des éléments sous tension.



Borne de mise à la terre. Destinée au raccordement du conducteur de mise à la terre de l'alimentation.

- Si l'équipement est utilisé dans un but non spécifié par le constructeur, la protection fournie avec cet équipement peut être affectée.
- Aucun composant (ou pièce) ne doit être remplacé s'il n'est pas explicitement spécifié comme tel par le constructeur.
- Tous les câblages doivent être conformes aux normes locales et doivent être réalisés par un personnel autorisé et expérimenté.
- La borne de masse doit être raccordée avant tout autre câblage (et débranchée en dernier).
- Il est obligatoire de connecter cet appareil sur une ligne possédant un moyen de coupure près de l'appareil.

CARACTERISTIQUES DE L'EQUIPEMENT

Tension d'alimentation	100 à 240 V
Fréquence	50 – 60 Hz
Puissance ou courant	100 VA

CONDITIONS AMBIANTES

Ne jamais utiliser cet équipement en présence de liquides ou vapeurs inflammables.

L'utilisation de tout instrument électrique dans un tel environnement pourrait présenter un risque pour la sécurité.

Température	Ambiante : 15 à 55°C
Humidité	10 à 90 % HR à 40°C
Vibration	Fréquence : 14 à 250 Hz Accélération 1 g

INSTALLATION DE L'EQUIPEMENT

Cet appareil doit être monté dans un panneau pour limiter l'accès aux bornes arrières par l'opérateur.



Befolgen Sie alle Sicherheitshinweise in diesen Unterlagen, um das Risiko eines Stromschlags zu verringern, der zu Körperverletzung führen kann.



Dieses Symbol warnt den Benutzer vor eventueller Berührungsgefahr, wo lebensgefährliche Spannungen zugänglich sein können.



Schützende Erdung. Für den Anschluß der schützenden Erdung der Versorgungssystemleitung.

- Bei Benutzung der Ausrüstungen auf nicht vom Hersteller angegebene Art und Weise kann der von der Ausrüstung gewährleistete Schutz beeinträchtigt werden.
- Ersetzen Sie keine Komponente (oder Teil), die/das nicht ausdrücklich vom Lieferanten als ersetzbar angegeben ist.
- Die gesamte Verkabelung muß den örtlichen Normen entsprechen und von zugelassenem, erfahrenem Personal durchgeführt werden.
- Die Erde muß vor allen anderen Kabeln angeschlossen (und zuletzt abgeklemmt) werden.
- In der Nähe der Ausrüstung muß ein Schalter in der Hauptstromversorgung vorhanden sein.

AUSRÜSTUNGSDATEN

Netzspannung	100 bis 240 V
Frequenz	50 – 60 Hz
Nennleistung	100 VA

UMGEBUNGSBEDINGUNGEN

Betreiben Sie das Gerät nicht in Gegenwart entflammbarer Flüssigkeiten oder Dämpfe. Der Betrieb elektrischer Geräte in solchen Umgebungen stellt ein Sicherheitsrisiko dar.

Temperatur	Umgebung : 15 bis 55°C
Feuchtigkeit	10 bis 90% RH - 40°C
Vibration	14 bis 250 Hz Beschleunigung 1 g

ANBRINGUNG DER AUSRÜSTUNGEN

Der Regler muß in ein Pult eingebaut sein, damit der Bediener nicht zu oft auf die hinteren Anschlüsse zugreifen muß.



Για την αποφυγή του κινδύνου ηλεκτροπληξίας που θα μπορούσε να προκαλέσει προσωπικό τραυματισμό, ακολουθείστε όλες τις υποδείξεις ασφαλείας αυτών των οδηγιών.



Το σύμβολο αυτό προειδοποιεί το χρήστη για πιθανό ηλεκτρικό κίνδυνο σε περίπτωση επαφής με επικίνδυνα μέρη της συσκευής.



Προστατευτικό τερματικό γείωσης. Παρέχεται για σύνδεση με τον αγωγό προστατευτικής γείωσης του συστήματος τροφοδοσίας.

- Εάν ο εξοπλισμός χρησιμοποιηθεί κατά τρόπο που δεν προβλέπεται από τον κατασκευαστή, διακινδυνεύεται η παρεχόμενη από τον εξοπλισμό προστασία.
- Μην αντικαταστήσετε κανένα μέρος (ή εξάρτημα) του οποίου η αντικατάσταση δεν προβλέπεται από τον κατασκευαστή.
- Όλες οι ηλεκτρικές εγκαταστάσεις πρέπει να είναι σύμφωνες με τα τοπικά πρότυπα και να πραγματοποιούνται από έμπειρους τεχνικούς.
- Το τερματικό εδάφους πρέπει να συνδέεται πριν από κάθε άλλη σύνδεση (και να αποσυνδέεται τελευταίο).
- Απαιτείται ένας διακόπτης στην κύρια ηλεκτρική εγκατάσταση τροφοδοσίας ηλεκτρικού κοντά στη συσκευή.

ΧΑΡΑΚΤΗΡΙΣΤΙΚΑ ΕΞΟΠΛΙΣΜΟΥ

Τροφοδοσία ισχύος 100 ως 240 V

Συχνότητα 50 – 60 Hz

Ισχύς ρεύματος 100 VA

ΣΥΝΘΗΚΕΣ ΠΕΡΙΒΑΛΛΟΝΤΟΣ

Αποφεύγετε τη λειτουργία του κοντά σε εύφλεκτα υγρά ή αέρια. Η λειτουργία οποιασδήποτε ηλεκτρικής συσκευής σε τέτοιο περιβάλλον εκθέτει σε κίνδυνο για την ασφάλεια.

Θερμοκρασία Περιβάλλοντος : 15 ως 55°C

Υγρασία 10 ως 90 % RH μη συμπυκνώσιμη / 40°C

Δόνηση 14 – 250 Hz

Επιτάχυνση 1 γ

ΕΓΚΑΤΑΣΤΑΣΗ ΕΞΟΠΛΙΣΜΟΥ

Η μονάδα αυτή πρέπει να μπει μέσα σε πλαίσιο για να περιορίζεται η πρόσβαση του χρήστη στα πίσω τερματικά.



Per ridurre i rischi di scariche elettriche che potrebbero causare alle persone, seguire tutte le precauzioni circa la sicurezza indicate in questa documentazione.



Questo simbolo avverte del pericolo di scossa elettrica nelle aree in cui sono accessibili conduttori sotto tensione.



Terminale di protezione verso terra. Previsto per il collegamento del conduttore di protezione verso terra del sistema di alimentazione.

- Se lo strumento viene utilizzato in modo diverso dalla specifica del costruttore, la protezione fornita dallo strumento può essere diversa.
- Non sostituire alcun componente (o parte) non specificato esplicitamente come ricambio dal vostro fornitore.
- Tutti i cablaggi devono essere in accordo con i regolamenti locali e devono essere eseguiti da personale esperto ed autorizzato.
- Il terminale di massa deve essere collegato prima di ogni altro filo (e scollegato per ultimo).
- E necessario che sia presente un interruttore nell'alimentazione principale accanto all'apparecchio.

ALIMENTAZIONE APPARECCHIATURA

Tensione di alimentazione	Da 100 a 240 V
Frequenza	50 – 60 Hz
Potenza o corrente	100 VA

CONDIZIONI AMBIENTALI

Non far funzionare l'apparecchio in presenza di liquidi o gas infiammabili, in quanto questo potrebbe essere estremamente pericoloso.

Temperatura	Ambiente : da 15 a 55°C
Umidità relativa	Da 10 a 90% UR a 40°C
Vibrazioni	Da 14 a 250 Hz
	Accelerazione 1 g

INSTALLAZIONE DELL'APPARECCHIO

Il apparecchio deve essere montato su un pannello per limitare l'accesso ai terminali posteriori.



Følg alle retningslinjene i dette dokumentet, slik at du reduserer risikoen for elektrisk støt og mulige personskader.



Dette symbolet advarer brukeren om tilgjengelige terminaler med farlige spenninger og en potensiell fare for elektrisk støt.



Jordingsterminal. kablen for jording av systemet skal tilknyttes til denne terminalen.

- Dersom utstyret benyttes på en måte annerledes enn spesifisert av produsent, kan utstyrets beskyttelsesgrad forringes.
- Ingen komponenter eller deler skal skiftes ut dersom de ikke er uttrykkelig spesifisert som utskiftbare av din forhandler.
- Det er påkrevet med en hovedstrømsbryter i nærheten av utstyret.
- All kabling må utføres i henhold til gjeldende forskrifter og installeres av autoriser og erfaren installatør.
- Jord må tilknyttes før all annen kabling (og frakobles sist).

UTSTYRSPESIFIKASJONER

Strømtilførsel	100 til 240 V
Nettfrekvens	50 – 60 Hz
Kraftforbruk	100 VA

OMGIVELSER

Instrumentet må ikke opereres i nærheten av lettantennelige væsker eller gasser. Bruk av elektriske instrumenter i slike omgivelser utgjør en sikkerhetsrisiko.

Temperatur	omgivelse : 15 til 55°C
Fuktighet	10 til 90% HR - 40°C
Vibrasjon	14 til 250 Hz akselerasjon 1 g

UTSTYRSINSTALLASJON

Pass på å montere panelene på regulatoren, slik at berøring av terminalene på baksiden forhindres.

INSTRUÇÕES DE SEGURANÇA

PO2I-6048



Para reduzir o risco de choque eléctrico que pode causar danos corporais, seguir todas as normas de segurança contidas nesta documentação.



Este símbolo avisa o utilizador sobre um eventual perigo de choque quando são acessíveis voltagens sob tensão perigosas.



Terminal de protecção de terra. Fornecido para ligação do condutor do sistema da protecção de terra.

- Se este equipamento for usado de modo não especificado pelo fabricante, a protecção fornecida pelo equipamento pode não ser adequada.
- Não se deve substituir qualquer componente (ou peça) que não seja explicitamente especificado como substituível pelo nosso revendedor.
- Toda a cablagem deve estar de acordo com os códigos eléctricos locais e deve ser realizada por pessoal experiente devidamente autorizado.
- O terminal de terra deve ser ligado antes de ser feita qualquer outra cablagem (e desligado em último lugar).
- Recomenda-se um comutador na fonte de alimentação principal próximo do equipamento.

ESPECIFICAÇÕES DO EQUIPAMENTO

Voltagem	100 a 240 V
Frequência	50 – 60 Hz
Potência ou consumo de corrente	100 VA

CONDIÇÕES AMBIENTAIS

Não operar o instrumento na presença de líquidos ou vapores inflamáveis. A operação de qualquer instrumento eléctrico em tal ambiente constitui um perigo para a segurança.

Temperatura	Ambiente : 15 a 55°C
Humidade	10 a 90% RH a 40°C
Vibração	14 a 250 Hz aceleração 1 g

INSTALAÇÃO DO EQUIPAMENTO

O Registrador deve ser montado num painel para limitar o acesso do operador aos terminais traseiros.



Para reducir el riesgo de choque eléctrico el cual podría causar lesiones personales, seguir todas las indicaciones de este documento.



Este símbolo previene al usuario de un riesgo potencial de descarga cuando se puede acceder a corrientes de tensión peligrosas.



Terminal de tierra de protección. Proporcionado para la conexión de la tierra de protección del conductor del sistema de alimentación.

- Si el equipo es utilizado de forma no especificada por el fabricante, la protección suministrada con el mismo podría resultar dañada.
- No reemplazar ningún componente (o parte) no explícitamente especificado por el suministrador.
- Todo el cableado debe realizarse de acuerdo con las normas eléctricas locales y debe ser realizado por personal experimentado.
- El terminal de tierra debe ser conectado antes que cualquier otro cable y desconectado el último.
- Se recomienda la instalación de un interruptor de la alimentación principal, cerca del equipo.

DATOS ELECTRICOS DEL EQUIPO

Tensión de alimentación	100 a 240 V
Frecuencia	50 – 60 Hz
Potencia o corriente	100 VA

CONDICIONES AMBIENTALES

No operar con el instrumento en presencia de líquidos o gases inflamables. La operación de cualquier equipo eléctrico en tal ambiente constituye un riesgo contra la seguridad.

Temperatura	Ambiente : 15 a 55°C
Humedad	10 a 90% RH a 40°C
Vibración	14 a 250 Hz aceleración 1 g

INSTALACION DEL EQUIPO

Este equipo debe ser montado en un panel para limitar al operador el acceso a los terminales traseros.

SÄKERHETSFÖRESKRIFTER

SW2I-6048



För att reducera riskerna av elektriska chocker som kan orsaka personskador, följ alla säkerhetsföreskrifter i denna dokumentation.



Denna symbol varnar användaren för risk för elchock vid tillfällig åtkomst av spänningsförande del.



Anslutning av skyddsjord. Avsedd för anslutning av elsystemets skyddsjordsledare.

- Om utrustningen används på ett sådant sätt, att det inte innefattas av tillverkarens specifikation, kan de inbyggda säkerhetsfunktionerna äventyras.
- Ersätt aldrig någon komponent (eller del) som inte är specificerad som ersättningsbar av tillverkaren.
- All ledningsdragnings måste utföras i enlighet med lokala bestämmelser och skall utföras av behörig personal med erfarenhet av sådant arbete.
- Skyddsjordsanslutningen skall anslutas före alla andra anslutningar (och losskopplas sist).
- En strömbrytare för näströmmen rekommenderas.

STRÖMFÖRSÖRJNING

Spänning	100 a 240 V
Frekvens	50 – 60 Hz
Effekt eller märkström	100 VA

OMGIVNINGSVILLKOR

Använd ej instrumentet i närhet av brännbara vätskor eller gaser. Användandet av instrumentet i sådant miljö är en direkt säkerhetsrisk.

Temperatur	Omgivande : 15 till 55°C
Fuktighet	10 till 90% RH - 40°C
Vibration	14 till 250 Hz acceleration 1 g

INSTALLATION

Instrumentet skall monteras i en panel eller i en låda för att undvika att personalen kommer i beröring med bakre inkopplingsplintar.

Sales and Service

For application assistance, current specifications, pricing, or name of the nearest Authorized Distributor, contact one of the offices below.

ARGENTINA

Honeywell S.A.I.C.
Belgrano 1156
Buenos Aires
Argentina
Tel. : 54 1 383 9290

ASIA PACIFIC

Honeywell Asia
Pacific Inc.
Room 3213-3225
Sun Kung Kai Centre
N° 30 Harbour Road
Wanchai
Hong Kong
Tel. : 852 829 82 98

AUSTRALIA

Honeywell Limited
5 Thomas Holt Drive
North Ryde Sydney
Nsw Australia 2113
Tel. : 61 2 353 7000

AUSTRIA

Honeywell Austria
G.M.B.H.
Handelskai 388
A1020 Vienna
Austria
Tel. : 43 1 727 800

BELGIUM

Honeywell S.A.
3 Avenue De Bourget
B-1140 Brussels
Belgium
Tel. : 32 2 728 27 11

BRAZIL

HONEYWELL DO
Brazil
And Cia
Rua Jose Alves Da
Chunha
Lima 172
Butanta
05360.050 Sao Paulo
Sp
Brazil
Tel. : 55 11 819 3755

BULGARIA

HONEYWELL EOOD
14, Iskarsko Chausse
POB 79
BG- 1592 Sofia
BULGARIA
Tel. : 359-791512/
794027/ 792198

CANADA

Honeywell Limited
The Honeywell Centre
300 Yorkland Blvd.
Toronto, Ontario
M2j 1s1
Canada
Tel.: 800 461 0013
Fax:: 416 502 5001

CZECH REPUBLIC

HONEYWELL,
Spol.S.R.O.
Budejovicka 1
140 21 Prague 4
Czech Republic
Tel. : 42 2 6112 3434

DENMARK

HONEYWELL A/S
Automatikvej 1
DK 2860 Soeborg
DENMARK
Tel. : 45 39 55 56 58

FINLAND

HONEYWELL OY
Ruukintie 8
FIN-02320 ESPOO 32
FINLAND
Tel. : 358 0 3480101

FRANCE

HONEYWELL S.A.
Bâtiment « le Mercure »
Parc Technologique de St
Aubin
Route de l'Orme
(CD 128)
91190 SAINT-AUBIN
FRANCE
Tel. from France:
01 60 19 80 00
From other countries:
33 1 60 19 80 00

GERMANY

HONEYWELL AG
Kaiserleistrasse 39
D-63067 OFFENBACH
GERMANY
Tel. : 49 69 80 64444

HUNGARY

HONEYWELL Kft
Gogol u 13
H-1133 BUDAPEST
HUNGARY
Tel. : 36 1 451 43 00

ICELAND

HONEYWELL
Hataekni .hf
Armuli 26
PO Box 8336
128 reykvjavik
Iceland
Tel. : 354 588 5000

ITALY

HONEYWELL S.p.A.
Via P. Gobetti, 2/b
20063 Cernusco Sul
Naviglio
ITALY
Tel. : 39 02 92146 1

MEXICO

HONEYWELL S.A. DE
CV
AV. CONSTITUYENTES
900
COL. LOMAS ALTAS
11950 MEXICO CITY
MEXICO
Tel. : 52 5 259 1966

THE NETHERLANDS

HONEYWELL BV
Laaderhoogtweg 18
1101 EA AMSTERDAM
ZO
THE NETHERLANDS
Tel. : 31 20 56 56 911

NORWAY

HONEYWELL A/S
Askerveien 61
PO Box 263
N-1371 ASKER
NORWAY
Tel. : 47 66 76 20 00

POLAND

HONEYWELL Sp.z.o.o
Ul Domaniewksa 41
02-672 WARSAW
POLAND
Tel. : 48 22 606 09 00

PORTUGAL

HONEYWELL
PORTUGAL LDA
Edificio Suecia II
Av. do Forte nr 3 - Piso 3
2795 CARNAXIDE
PORTUGAL
Tel. : 351 1 424 50 00

REPUBLIC OF IRELAND

HONEYWELL
Unit 1
Robinhood Business
Park
Robinhood Road
DUBLIN 22
Republic of Ireland
Tel. : 353 1 4565944

REPUBLIC OF SINGAPORE

HONEYWELL PTE LTD
BLOCK 750E CHAI
CHEE ROAD
06-01 CHAI CHEE
IND.PARK
1646 SINGAPORE
REP. OF SINGAPORE
Tel. : 65 2490 100

REPUBLIC OF SOUTH AFRICA

HONEYWELL
Southern Africa
PO BOX 138
Milneron 7435
REPUBLIC OF SOUTH
AFRICA
Tel. : 27 11 805 12 01

ROMANIA

HONEYWELL Office
Bucharest
147 Aurel Vlaicu Str.,
Sc.Z.,
Apt 61/62
R-72921 Bucharest
ROMANIA
Tel. : 40-1 211 00 76/
211 79

RUSSIA

HONEYWELL INC
4 th Floor Administrative
Building of AO "Luzhniki"
Management
24 Luzhniki
119048 Moscow
RUSSIA
Tel. : 7 095 796 98 00/01

SLOVAKIA

HONEYWELL Ltd
Mlynske nivy 73
PO Box 75
820 07 BRATISLAVA 27
SLOVAKIA
Tel. : 421 7 52 47
400/425

SPAIN

HONEYWELL S.A
Factory
Josefa Valcarcel, 24
28027 MADRID
SPAIN
Tel. : 34 91 31 3 61 00

SWEDEN

HONEYWELL A.B.
S-127 86 Skarholmen
STOCKHOLM
SWEDEN
Tel. : 46 8 775 55 00

SWITZERLAND

HONEYWELL A.G.
Hertistrasse 2
8304 WALLISELLEN
SWITZERLAND
Tel. : 41 1 831 02 71

TURKEY

HONEYWELL A.S.
Caryiryolu Sok No. 7
Ucgen Plaza, Kat 5-6-7
Icerenkoy 81120
Instanbul
Turkey
Tel (90-216) 575 66 00

UNITED KINGDOM

HONEYWELL
Honeywell House
Arlington Business Park
Bracknell,
Berkshire
RG12 1EB
Tel: +44 (0) 1344 656000

U.S.A.

HONEYWELL INC.
INDUSTRIAL PROCESS
CONTROLS
1100 VIRGINIA DRIVE
PA 19034-3260
FT. WASHINGTON
U.S.A.
Tel. : 1-800-343-0228

VENEZUELA

HONEYWELL CA
APARTADO 61314
1060 CARACAS
VENEZUELA
Tel. : 58 2 239 0211

Honeywell

Industrial Measurement and Control

Honeywell
1100 Virginia Drive
Fort Washington, PA 19034

51-52-25-62 Rev. H 1203 Printed in USA

www.honeywell.com/imc