

Integrated IR Butane Datasheet

DS-0313 INIR-BU1.8%, ISSUE 1
Copyright © SGX Sensortech 2012-2020



Integrated IR FEATURES

- Gas Sensor with **Automatic Switchover** between ranges,
- **High Resolution** up to 20ppm,
- **Detectivity Level** at 100ppm,
- **Multi-sensor mode**,
- Analog Output of gas concentration,
- Serial port communication,
- **Internal Temperature** sensor
- Active & Reference **Signals Monitored**
- Full **Faults Diagnostics & Error Generation**
- Cyclic Redundancy Check (**CRC**)
- **Typical Low power** consumption < 100mW (Average)
- **Factory calibrated** for Butane
- **Evaluation Kit** available including **PC software** for easy testing and production calibration functions
- Easy implementation into **Sensors Network**
- Design for use in Hazardous Areas
- **Certified Sensor** for use in Explosive Atmospheres (EX)

GENERAL DESCRIPTION

The Integrated IR (INIR) sensor has been designed with the latest technology, using a microcontroller with an ARM7 core and via software design the necessary techniques have been implemented to increase the reliability of the device therefore minimize the probability of faults.

The INIR is a user friendly digital Gas Sensor, which is designed to use the latest SGX Sensortech's Infrared technology.

The sensor is designed to decrease the implementation time therefore increase productivity. The Integrated IR sensor incorporates the necessary electronics and embedded software to operate from a low voltage DC power supply. The sensor will process the raw signals to output a linear, temperature compensated signal proportional to the gas concentration applied. The output signal is available in digital and analogue forms.

The SGX Sensortech Integrated IR Gas Sensor provides users with a simple method of incorporating an Infrared Sensor into their gas detection instrument which will significantly reduce the development time and expertise required during the design and implementation phase. The Integrated IR can also be factory calibrated to allow installation without the need for recalibration.

RECOMMENDED APPLICATIONS

- **Automation & Control**
- **Indoor Air Quality**
- **Industrial Health & Safety**

TECHNICAL SPECS

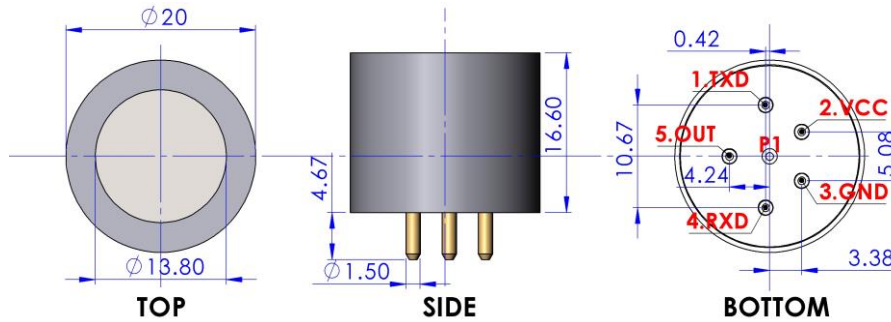

ABSOLUTE MAXIMUM RATINGS

Power Supply	Min	Typical	Max
Supply Voltage	3.2 VDC	3.3 VDC	5.25 VDC
Average Current Consumption	30mA	32mA	35 mA*
*Inrush Current can be up to 65mA			
Logic Outputs Level	LOW Voltage Level(VOL) : 0.6V Maximum HIGH Voltage Level(VOH): 2.0V Minimum 1.6mA source current maximum		
Logic Inputs Level	LOW Voltage Level(VINL): 0.4V Maximum HIGH Voltage Level(VINH): 2.0V Minimum		
Humidity			
Operating Humidity	0%	50%	99%
Storage Humidity	0%	50%	90%
Condensation (>100% Humidity)	Sensor's Detection Limit, Stability & Linearity would be affected, algorithms are implemented to minimize as the effect.		
Temperature			
Operating Temp.	-40 °C	+20 °C	+75 °C
Storage Temp.	-20 °C	+20 °C	+55 °C
Temp. Cycle Limits		0.8°C/min	1.3°C/min
Pressure (Compensation will be required)			
Operating Pressure	80kPa	-	120kPa
Storage Pressure	80kPa	-	120kPa
Performance			
DAC Resolution	12-Bit at 0.0-2.5 Volts DC Max Scalable according to Gas Conc. Operating Range		
Digital signal format	8 data bits, 1 stop bit, no parity		
Standard baud rate	38400 as default, 115200, 19200, 9600		
Dimensions			
Diameter (D)	19.9mm	20mm	20.1mm
Height (H)	16.50mm	16.60mm	16.70mm
Pins Height (pH)	4.0mm	4.8mm	5.6mm
Body Material	Stainless Steel		
Weight	25 g	29 g	33 g
Gas Sensor Sockets			
S1	5-Pin , Polygon Topology		

PIN CONFIGURATION

Pin	Name	Description
1	TXD	Data transmitted from the Integrated IR.
2	+VCC	3.2 Volts – 5.25 Volts DC input to Integrated IR
3	GND	GND Plane, 0 Volts reference for Integrated IR
4	RXD	Data received by the Integrated IR.
5	OUT	Analog Output. Scalable range, see Application Note 1 Integrated IR Protocol & Calibration for details.
Pad	Pad	Bootloader Pad. Not used by the customer.

NOTE1: All Dimensions in mm. All tolerances Linear +/- 0.1mm and Angular 0.5° unless otherwise stated.

NOTE2: Do not solder pins. INIR Series sensors are designed to press-fit into PCB sockets. The end-user should choose a socket to accommodate the full sensor pin length. This will ensure a stable mechanical location as well as good electrical contact. SGX Sensortech recommend the Wearn's Cambion type 450-1813-01-03-00 single-pole solder mount socket with through hole, or a suitable equivalent.