

TVD 1.3

Power Supply Module for Direct Connection to 3 x AC 380...480V Mains Supply

Applications Manual

DOK-POWER*-TVD*1.3****-ANW1-EN-P



Title TVD 1.3
Supply Module for Direct Connetion to 3 x AC 380...480V Mains Supply

Type of documentation Applicationsbeschreibung

Document code DOK-POWER*-TVD*1.3****-ANW1-EN-E1,44

Internal file reference

- Mappe 6
- TVD13-AN.pdf
- 209-0049-4309-01

Reference This electronic document is based on the hardcopy document with document desig.: DOK-POWER*-TVD*1.3****-ANW1-EN-P • 11.96

The purpose of the documentation This document serves to:

- define the applications range
- support the electrical construction of the machine
- support the mechanical construction of the cabinet
- mounting and installation
- selecting the additional components
- help with the clearing of faults

Editing sequence

Doc. designations of previous editions	Status	Comments
209-0049-4309-00 DE/07.96	JUL./96	Preliminary without print
DOK-POWER*-TVD*1.3****-ANW1-EN-P	JUL./96	1st edition
DOK-POWER*-TVD*1.3****-ANW1-EN-P	NOV./96	2nd edition
DOK-POWER*-TVD*1.3****-ANW1-EN-E1,44	Feb./97	1st edition E-Dok

Copyright © INDRAMAT GmbH, 1996
Copying this document, and giving it to others and the use or communication of the contents thereof without express authority are forbidden. Offenders are liable for the payment of damages. All rights are reserved in the event of the grant of a patent or the registration of a utility model or design (DIN 34-1).
The electronic documentation (E-doc) may be copied as often as needed if such are to be used by the consumer for the purpose intended.

Validity All rights are reserved with respect to the content of this documentation and the availability of the product.

Published by INDRAMAT GmbH • Bgm.-Dr.-Nebel-Straße 2 • D-97816 Lohr
Telefon 0 93 52 / 40-0 • Tx 689421 • Fax 0 93 52 / 40-48 85

Dept. ENA (DE, FS)

Table of Contents

1.	Construction of INDRAMAT Modular A.C. Drive System	7
1.1.	Main functions of the TVD 1.3	8
2.	Range of Applications	9
2.1	Functional power features of the TVD 1.3	10
2.2.	Power ratings of the TVD 1.3	11
2.3.	Overload Capabilities of the TVD 1.3	11
2.4.	Technical Data - TVD 1.3	12
2.5.	Ambient Conditions	13
3.	Electrical Connections – Installation Guidelines	14
3.1.	Interconnect diagram TVD 1.3 with NAM 1.3	15
3.2.	TVD 1.3 interconnect diagram with individual, additional components	16
3.3	Mains connection devices	17
3.4.	Mains connection to power circuits	19
3.5.	Fuse protection for direct mains connection	21
3.6.	Mains supply earthing requirements	21
3.7.	Commutation choke	23
3.8.	DC bus circuit	23
3.9.	DC bus smoothing choke	24
3.10.	Additional DC bus capacitance	24
3.11.	Bridge circuit capacitance	24
3.12.	Additional bleeder module TBM	25
3.13.	External bleeder resistor	26
3.14.	Supply to electronics and blower	27
3.15.	Electronics supply buffer capacitance	28
3.16.	Electronics supply and signal exchange connections	29
3.17.	Residual current operated devices	30
3.18.	Control cabinet testing	31
3.19.	Mounting the TVD 1.3 into the control cabinet	31

3.20. Heat loss inside the control cabinet	33
3.21. Safety clearance inside the control cabinet	33
3.22. Front view of the TVD 1.3	34
4. TVD 1.3 Interconnections	35
4.1. Optional Control Possibilities	35
4.2. TVD interconnect with DC bus dynamic braking	36
4.3. TVD interconnect with E-stop relay with DC bus dynamic braking	38
4.4. TVD interconnect without DC bus dynamic braking	40
4.5. TVD interconnect for a position-controlled braking of the drives ...	42
5. Terminal Descriptions	44
5.1. DC bus short-circuiting	44
5.2. Power off	44
5.3. Power on	44
5.4. Stopping the drives in an E-stop or a power failure	45
5.5. Signal Voltages	46
5.6. "Ready" status	46
5.7. Power OK	48
5.8. Regenerated power too high	48
5.9. Temperature Pre-Warning	49
5.10. Mains contactor de-energized	49
5.11. Mains contactor energized	49
6. Troubleshooting	50
6.1. Localizing the fault	50
6.2. Diagnostic display	53
6.3. Definition of the displays	54
6.4. Rating plate data	57
7. Dimensional data	58
7.1. Dimension sheet TDV 1.3 power supply module	58

7.2.	Dimension sheet NAM 1.3 power adapting module	59
7.3.	Dimension sheet CZ 1.2-01-7 bus voltage capacitor	60
7.4.	Dimension sheet KD 23/26 commutating chokes	61
7.5.	Dimension sheet DC bus smoothing choke GLD 16/17	61
7.6.	Dimension sheet CZ 1.02 auxiliary capacitance	62
7.7.	Dimension sheet TCM 1.1 aux. capacitance mod.	62
7.8.	Dimension sheet TBM aux. bleeder module	63
7.9.	DST Autotransformers with a secundar or output voltage of 380...460 V	64
8.	Order information	65
8.1.	Type codes TVD	65
8.2.	Available supply module types of the TVD 1.3 and accessories ...	65
8.3.	Overview of electrical connecting accessories	66
8.4.	Overview of 16-pin bus cable for NAM 1.3	66
8.5.	Item list of mains supply with TVD 1.3	67
9.	Index	68

Empty
page

1. Construction of INDRAMAT Modular A.C. Drive System

The modular AC drive system from INDRAMAT is made up of

- auxiliary units
- supply modules and
- drive modules.

These can be combined depending upon the power and functionalities required.

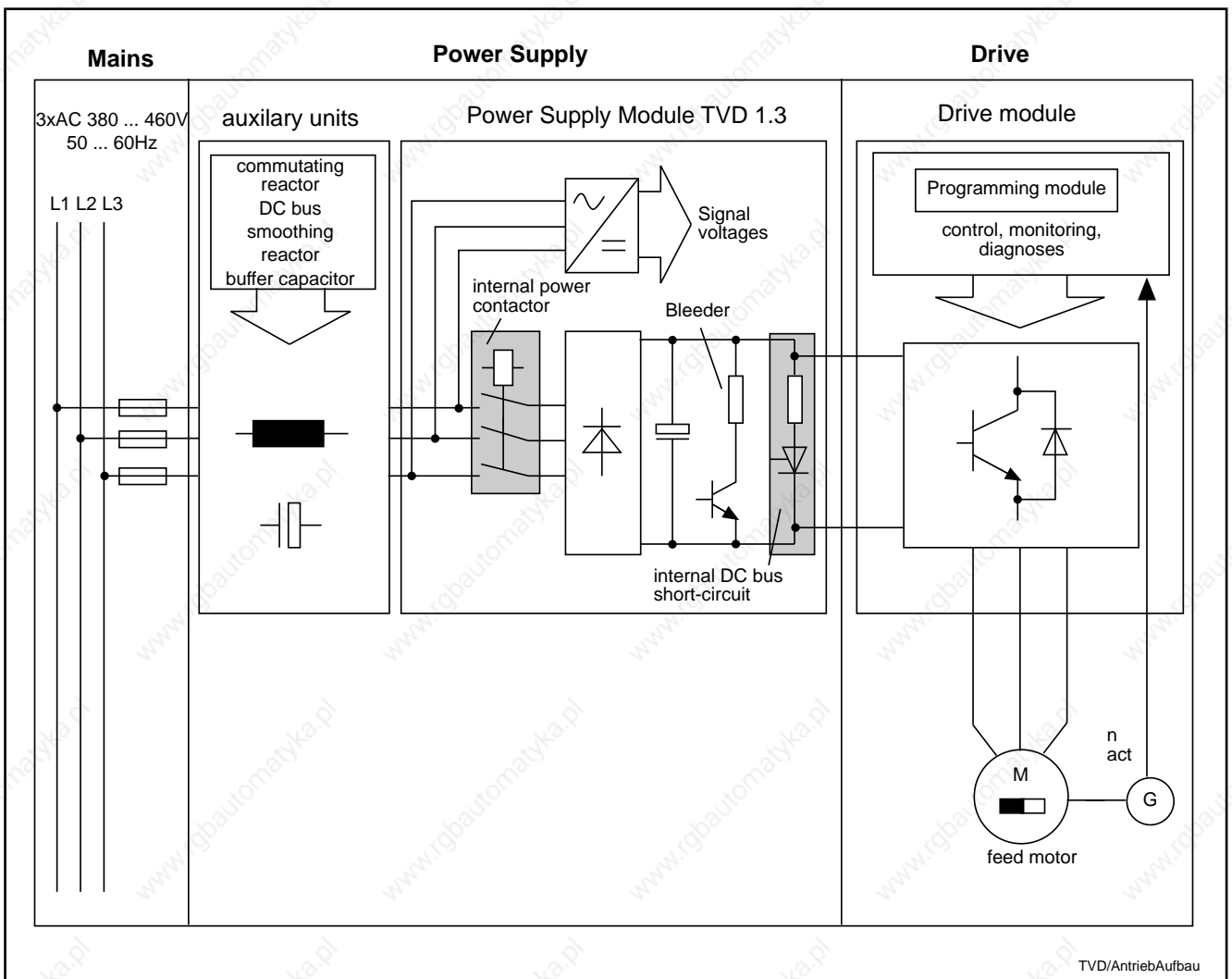

Fig. 1.1: The TVD 1.3 supply module as part of the INDRAMAT AC drive system

1.1. Main functions of the TVD 1.3

Power supply to the drives

The high-voltage link rectifies the three-phase mains AC and provides a regulated DC bus circuit voltage for the power feed to the drives. A buffer capacitor takes care of any necessary smoothing. When the drives are in generator mode, the regenerated power is absorbed by the bleeder resistor and transformed into heat. The drives can be disconnected from the mains by the TVD's internal power contactor.

Supply to the electronics

The TVD 1.3 provides the +24VL and +/-15VM for all connected drive modules. In the event of a power failure, the signal voltages are supplied from the DC bus circuit. Therefore, as the drives operate as a generator, the electronics of the drives remain functional.

Drive system monitoring

The TVD 1.3 is equipped with extensive monitoring functions. These communicate with the drive modules via the wire ribbon cable.

The Bb1 contact is critical to the ready state of the drive system. The power contactor cannot be energized until the Bb1 contact is closed.

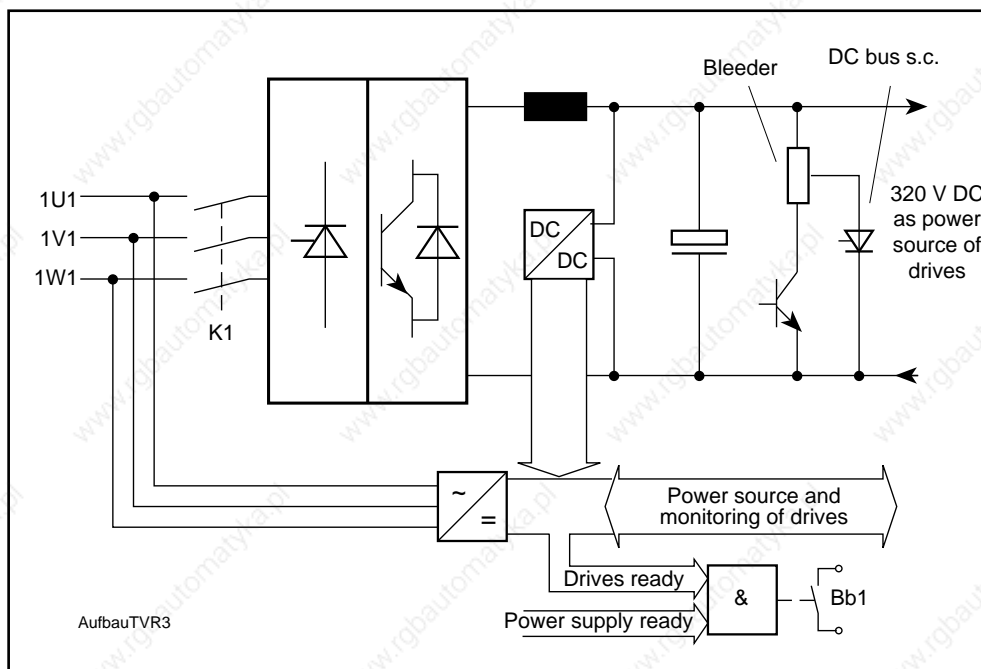

Fig. 1.2: The basic construction of the TVD 1.3

2. Range of Applications

INDRAMAT drives up to a continuous mechanical output of 12kW can be run from the TVD line of supply modules.

The TVD 1.3 operates without mains regeneration.

Drives with mains regeneration for regenerated power exceeding 2 kW are, however, available.

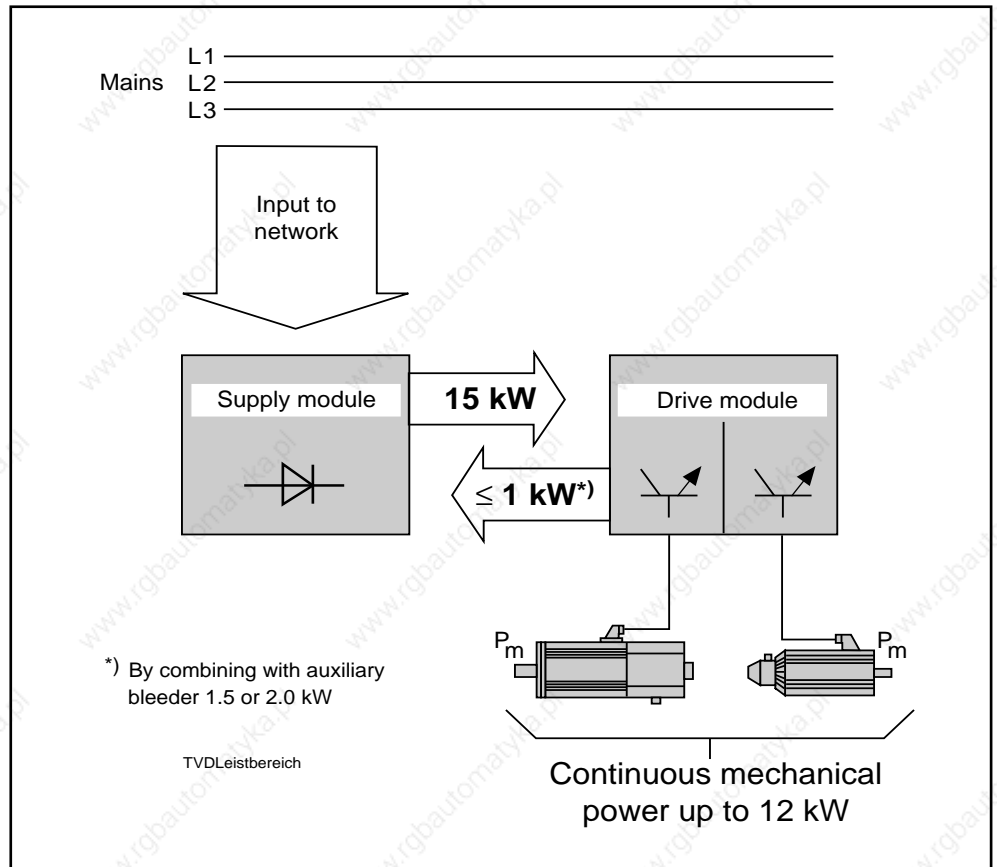

Fig. 2.1: Power range of the applications of the TVD 1.3

2.1 Functional power features of the TVD 1.3

- **Connected load**

The TVD 1.3 can be operated with power systems of 3 x AC 380..480V, 50...60Hz without a transformer. Additional auxiliary units are offered (NAM 1.3..) which suppress reactions on the power system.

- **Power shutdowns** by internal contactors

The contactor to shut down power to the power system of the drives is an integrated component of the TVD 1.3.

- **Internal DC bus dynamic braking**

Motors with permanent magnetic fields can be braked to a standstill by the DC bus dynamic brake in the event of fault conditions in the drive electronics.

- **How the drive system responds to a power failure**

can be programmed by inserting an external jumper:

- without a jumper, the drives brake at maximum torque
- with a jumper, a signal via a potential-free contact is transmitted to the NC control unit which can then brake the drives controlled to a standstill.

Costly tools and workpieces are thus protected against damage.

- **Regulated DC bus voltage**

Drive dynamics maintained with mains undervoltage.

- **Charging current limit of the DC bus capacitors**

The inrush current does not have to be taken into consideration when selecting the switching devices of the power system. This extends the service life of these devices.

- **Extreme load capabilities of the control voltage**

Up to ten drive modules can generally mounted to one supply module.

- **Easy to service**

The signal leads are connected via plug-in screw clamps.

- **Two different power stages available**

The supply module TVD 1.3 is available with a continuous DC bus power of 7.5 kW or 15 kW. This means that the power supply can be optimally matched to the requirements of the respective application.

- **Overload capabilities of the TVD 1.3**

The TVD 1.3 can overloaded for a short duration for the purpose of accelerating feed and main drives.

The maximum possible acceleration power, as relates to the duration of acceleration, is outlined in the section "Overload Capabilities of the TVD 1.3". The values found there must be taken into account during project planning and **may not** be exceeded.

- **UL Registered**

The device is made according the UL-Standard.

2.2. Power ratings of the TVD 1.3

The TVD 1.3 is available with a DC bus continuous power of 7.5 kW and 15 kW. It can be combined with an auxiliary bleeder module. This means that the power supply can be optimally matched to the requirements of the respective application.

(1)	(2)	(3)	(4)	(5)	(6)	(7)	(8)	(9)	Power supply components		
$\frac{P_{DC}}{kW}$	$\frac{P_{KB-3}}{kW}$	$\frac{P_{KB-0.3}}{kW}$	$\frac{P_{BD}}{kW}$	$\frac{P_{BM}}{kW}$	$\frac{W_{max}}{kWs}$	$\frac{P_m}{kW}$	$\frac{P_{mKB-3}}{kW}$	$\frac{P_{mKB-0.3}}{kW}$	TVD 1.3	Power conn. module	Auxiliary bleeder module
7,5	15	22,5	0.5	20	30	6	12	18	-08-03	NAM 1.3-08	-----
7,5	15	22,5	1.5	60	130	6	12	18	-08-03	NAM 1.3-08	TBM 1.2-40-W1
15	30	45	1.0	40	60	12	24	36	-15-03	NAM 1.3-15	-----
15	30	45	2.0	80	160	12	24	36	-15-03	NAM 1.3-15	TBM 1.2-40-W1

(1) P_{DC} = continuous DC bus power	(6) W_{max} = maximum regenerated energy
(2) P_{KB-3} = DC bus short-term power for 3s (accel. of spindle drive)	(7) P_m = mechanical output for ON time of > 10s
(3) $P_{KB-0.3}$ = DC bus peak power for 0.3s (accel. feed drives)	(8) P_{mKB-3} = mechanical short-term output for 3s (accel. of spindle drive)
(4) P_{BD} = Bleeder continuous power	(9) $P_{mKB-0.3}$ = mechanical peak output for 0.3s (accel. feed drives)
(5) P_{BM} = Bleeder peak power	

Fig. 2.2: Power ratings in the TVD 1.3

2.3. Overload Capabilities of the TVD 1.3

The TVD 1.3 can be overloaded for a short duration for the purpose of accelerating feed and spindle drives.



The maximum acceleration ratings must be taken into account during project planning and may not be exceeded!

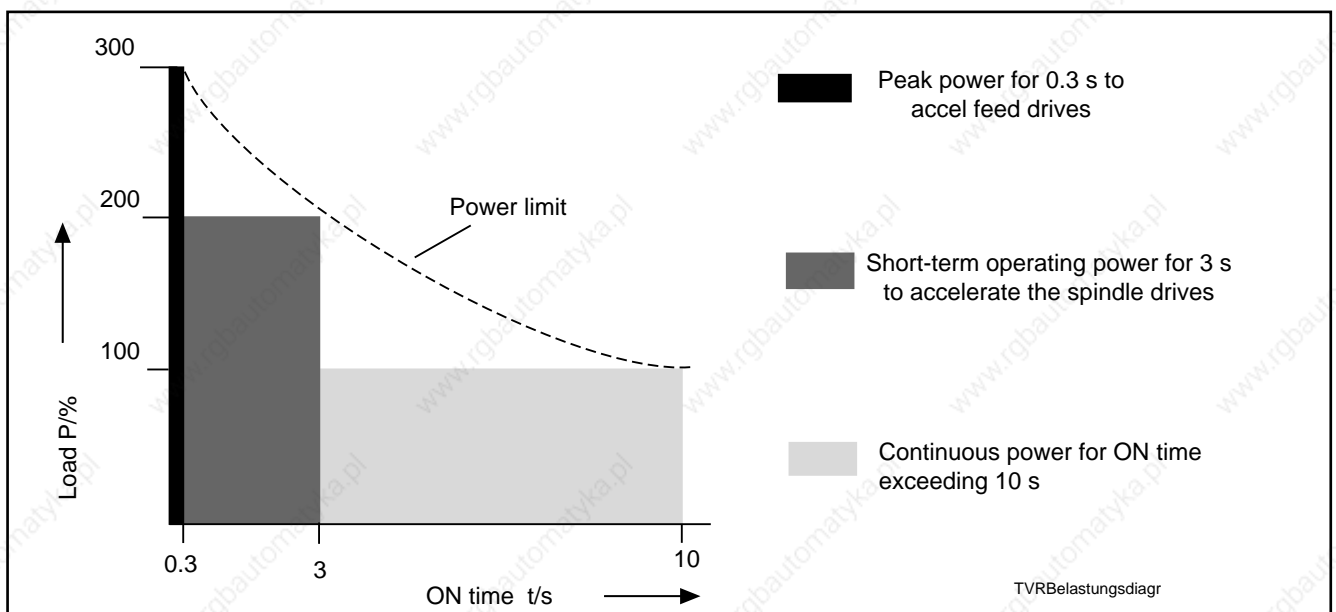

Fig. 2.3: Load diagram - TVD 1.3

2.4. Technical Data - TVD 1.3

Designation	Symbol	Unit	TVD 1.3-15-3	TVD 1.3-08-3
Power section				
Input voltage	U(ACN)	(V)	3 x 380 ... 480 ($\pm 10\%$)	
Frequency	f(N)	(Hz)	50 ... 60	
DC bus voltage	U(DC)	(V)	320 ($\pm 5\%$)	
Continuous DC bus power	P(DC)	(kW)	15	7.5
Peak DC bus power (for 0.3 s)	P(KB-03)	(kW)	45	22.5
Bleeder continuous power	P(BD)	(kW)	1	0.5
Bleeder peak power	P(BM)	(kW)	40	20
Maximum regenerated energy	W(max)	(kWs)	60	30
Power dissipation with maximum power (without bleeder loss)	P(v)	(W)	330	180
Basic loss		(W)		75
Power loss per kW continuous DC bus power			17	14
Weight	m	(kg)	11,2	10.5
Electronics supply				
Input voltage	U(AC)	(V)	3 x 380 ... 480 ($\pm 10\%$)	
Frequency	f(N)	(Hz)	50 ... 60	
Incomming power	S(el)	(VA)	300	
Control voltage output				
+ 24V load voltage	U(L)	(V)	22 ... 26	
+ 24VL continuous current	I(UL)	(A)	7.5	
+ 24VL ripple		(%)	2	
$\pm 15V$ measuring voltage	U(M)	(V)	14.9 ... 15.1	
+ 15VM continuous current	I(+UM)	(A)	2.5	
- 15VM continuous current	I(-UM)	(A)	1.5 (2.0) ¹⁾	
$\pm 15VM$ ripple		(%)	0.1	
Ambient conditions				
Permissible ambient temperature with rated data	T(um)	(°C)	+5 ... +45	
Maximum permissible ambient temperature with derated data	T(umr)	(°C)	55	
Storage and transport temperatures	T(L)	(°C)	-30 ... +85	
Installation elevation with derating			max. 1000 meters above sea level	
Permissible relative humidity			max. 95%	
Permissible absolute humidity			25g water / m ³ Luft	
Protection category			IP 10 per DIN 40 050	
Contamination level			non-conductive dirt, no condensate	
Suitable auxiliary units			NAM 1.3-15	NAM 1.3-08
¹⁾ The -15VM can be loaded with a maximum of 2 A. The load of + 15VM and - 15VM combined may not exceed 4 A.				

Fig. 2.4: Technical data of supply module TVD 1.3

2.5. Ambient Conditions

Increased ambient temperatures

The DC bus power and control voltage loads listed in the data sheets apply to an ambient temperature of +5 to +45°C. The maximum permissible ambient temperature may equal +55 °C. The power data, in this case, derate as per the diagram below.

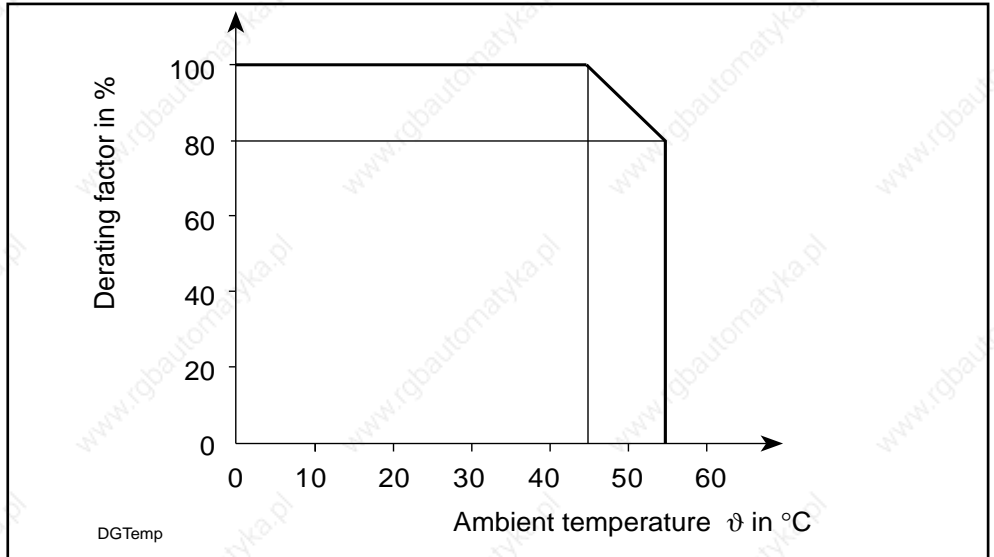

Fig. 2.5: The derated power data with increased ambient temperatures

Installation elevations exceeding 1000 m

The power data is derated as per the following diagrams in the case of installation of 1000 meters above sea level.

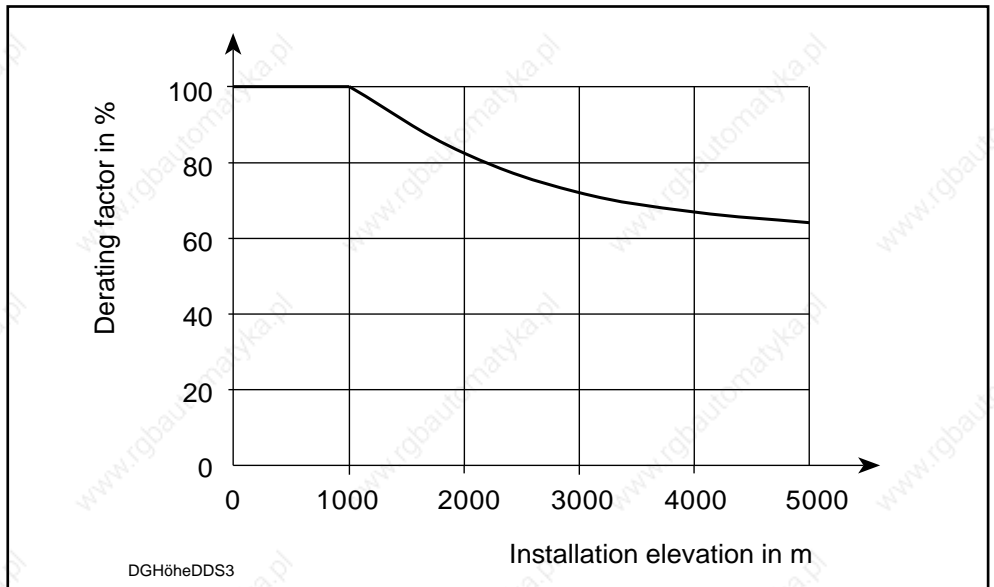

Fig. 2.6: Power data derated for installation elevations exceeding 1000 meters

3. Electrical Connections – Installation Guidelines



The interconnection diagram found in this documentation is a recommendation of the equipment manufacturer.

The wiring diagram of the machine builder should be used for installation.

3.1. Interconnect diagram TVD 1.3 with NAM 1.3

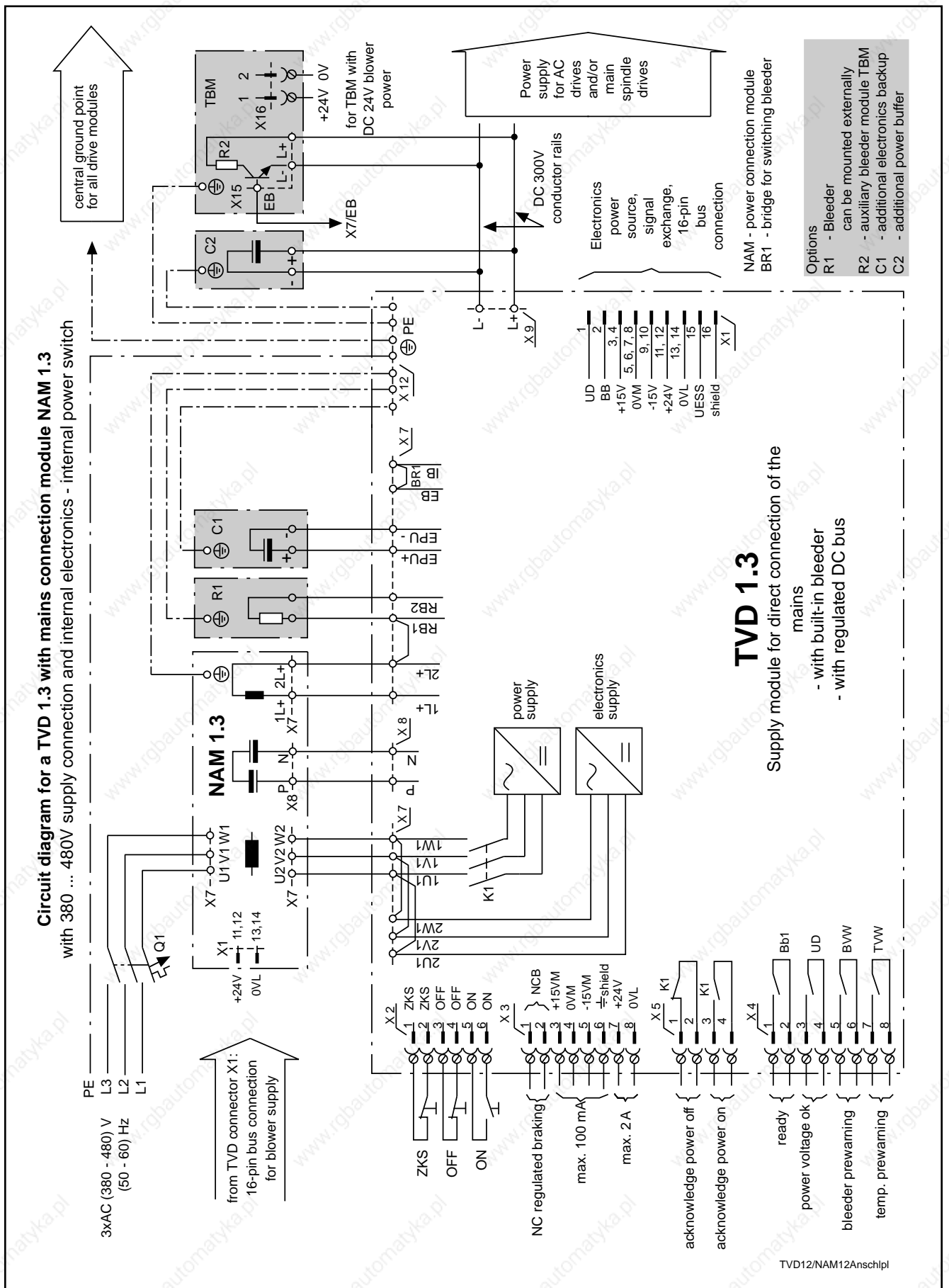

Fig. 3.1: Interconnect diagram -TVD 1.3 supply module with NAM 1.3

3.2. TVD 1.3 interconnect diagram with individual, additional components

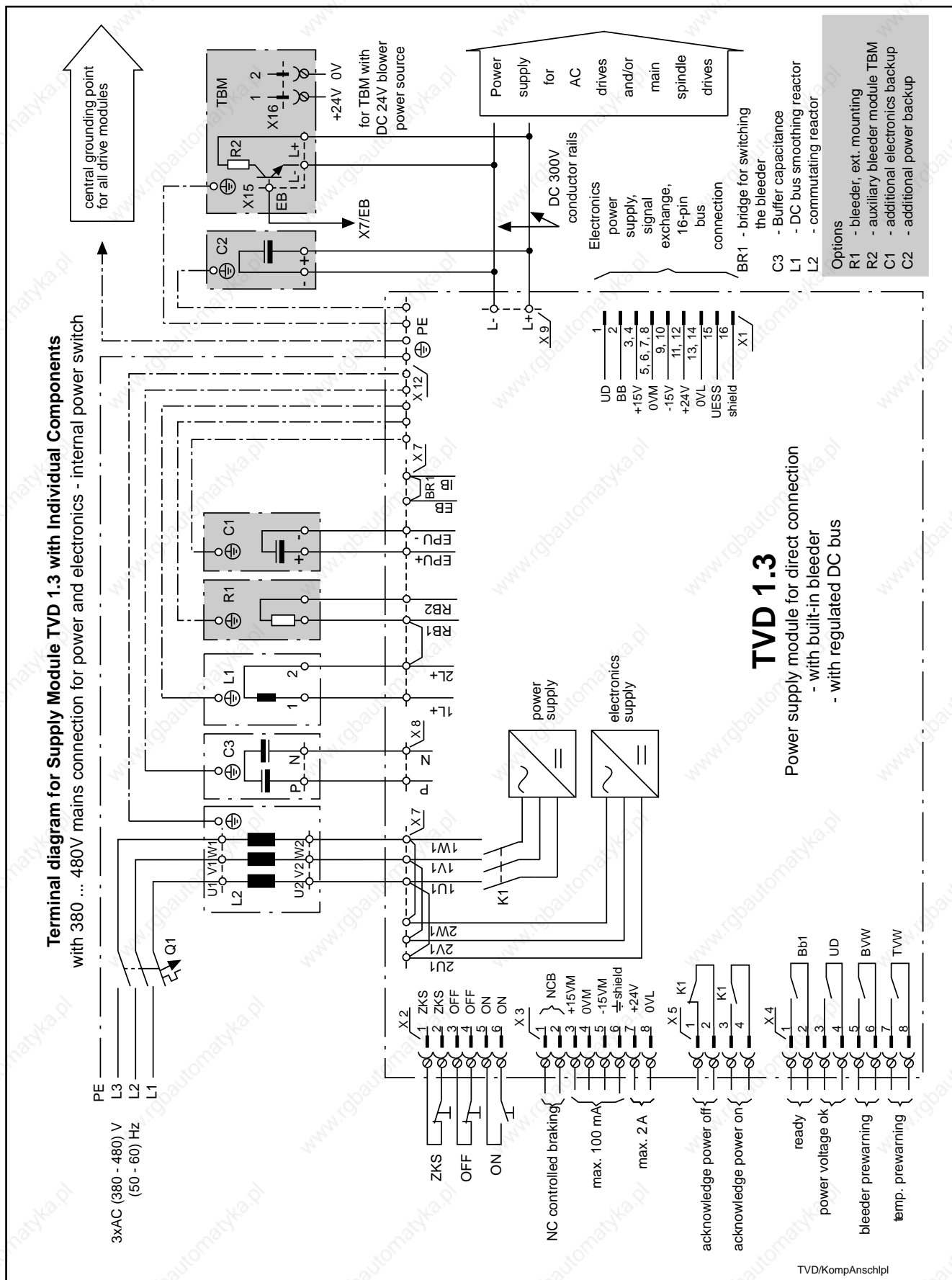

Fig. 3.2: Interconnect diagram of TVD 1.3 supply module with individual additional components

3.3 Mains connection devices

Due to regulated current consumption, the TVD 1.3 supply module offers the lowest possible mains loading without reactive current.

Current regulators in switched-mode power supply system cause mains system perturbations, the level of which depend on existing system conditions, i.e., short-circuit power or mains inductance, at the installation site.

To eliminate mains perturbation, the TVD 1.3 supply module is operated from the mains supply via auxiliary devices.

The auxiliary devices are available as either compact mains connection module NAM 1.3 or in the form of individual components.

TVD 1.3 with adapter module NAM 1.3

All the necessary components like the commutation choke, storage capacitor and DC bus smoothing choke, are in the mains connection module. This keeps installation work to a minimum.

Available device combinations:

Supply module	Mains connection module
TVD 1.3-08-3	NAM 1.3-08
TVD 1.3-15-3	NAM 1.3-15

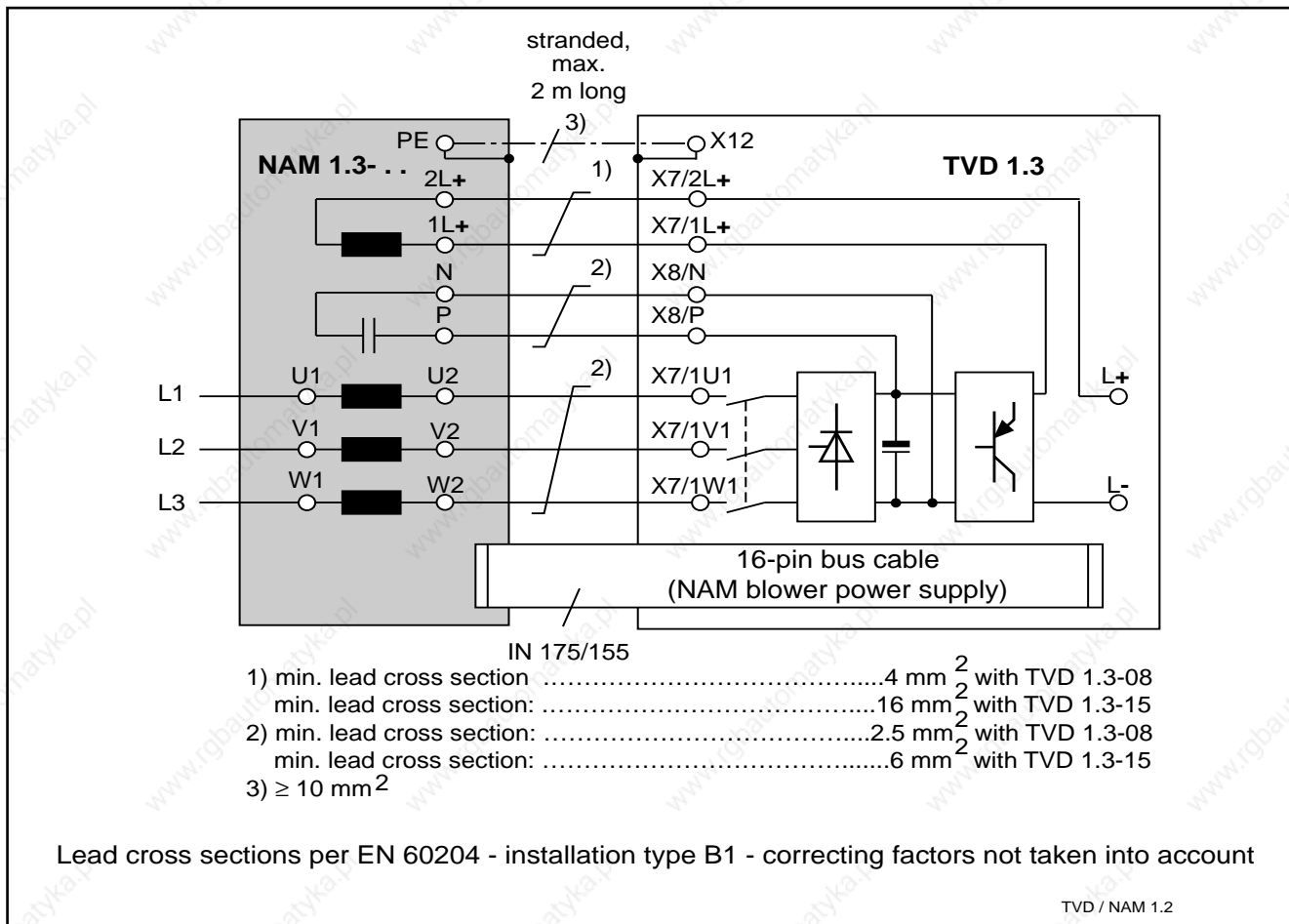

Fig. 3.3: Connecting a TVD 1.3 supply module to the mains via adapter module NAM 1.3

TVD 1.3 with separate components

If modular installation is not possible due to space restrictions, then the supply module can also be connected to the mains via separate components.

Required components:

Supply module	Commutation choke	Buffer capacitor	DC bus smoothing choke
TVD 1.3-08-3	KD 26	CZ 1.2-01-7	GLD 16
TVD 1.3-15-3	KD 23	CZ 1.2-01-7	GLD 17

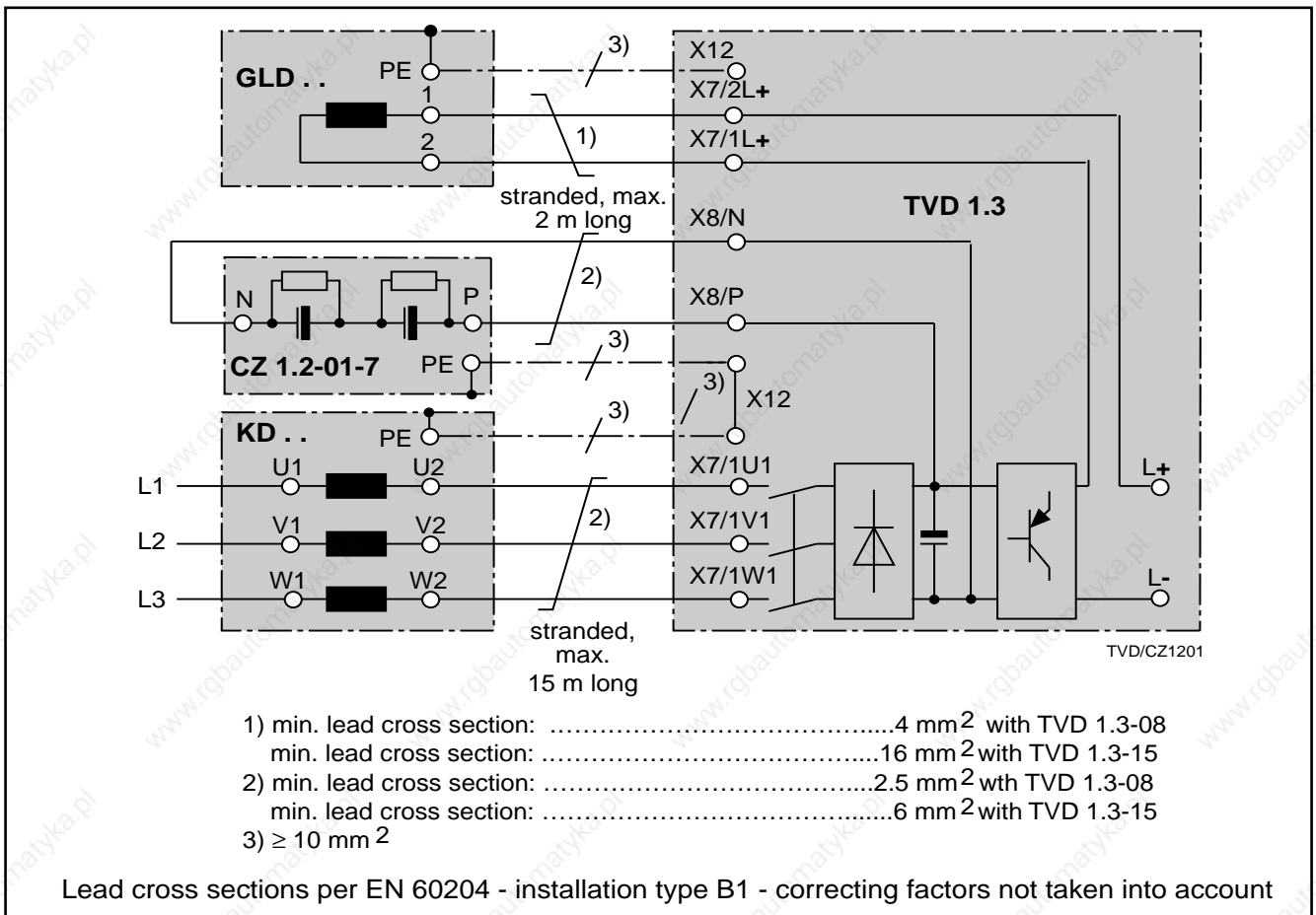

Fig. 3.4: Connecting a TVD 1.3 to the mains with individual components

3.4. Mains connection to power circuits

Direct mains connection The TVD 1.3 can be connected to 3 x AC 380...480V, 50...60Hz three-phase AC mains supplies without the need for a transformer. See section 3.5 for fuse protection information.

The power and electronic supply connections are strapped at the time of delivery. Generally, a separate connection for the power source of the electronics is not required.

Supply system requirements	Mains voltage:	3x AC 380 ... 480 V; $\pm 10\%$
	Mains frequency:	50 ... 60 Hz; ± 2 Hz
	Voltage interrupt:	Maximum 8 ms at base load and 380 V mains voltage without additional capacitance. There must be a timespan of > 1s between sequential interrupts.
	Voltage dips:	20 % of the peak voltage for a maximum of one period, with 3 x 380V; a corresponding percentage with higher voltages. There must be a timespan of > 1s between sequential interrupts.

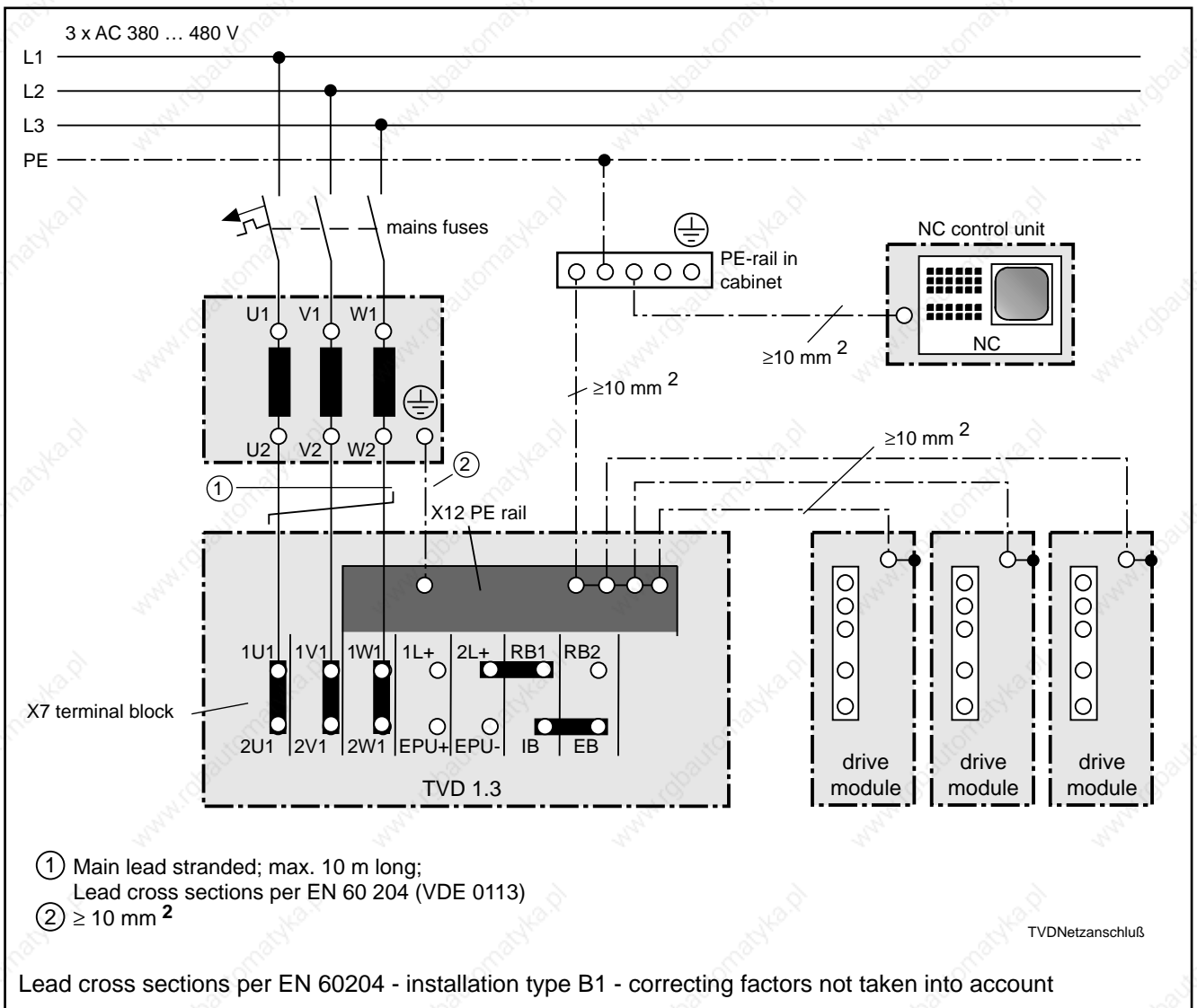

Fig. 3.5: Connecting block X7 with mutual power and electronics supply



If the modular drives are to be operated in residential or light industrial areas, then it may be necessary to mount an rf interference filter to maintain the limit values for the emission of interference (rf interference suppression).

Each drive module must be connected to the PE-rail of the TVD with a separate ground lead.



The leakage current via the protective conductor is greater than 3.5 mA AC. A permanent connection is thus required for the TVD.

Mains connection via a transformer

A transformer is needed if the mains voltage is less than 3 x 380V or greater than 3 x 480V.

The mains inductance (leakage inductance) from transformers can vary significantly depending on power and type of construction. Mains connection components are therefore still needed even if transformers are used (see section 3.3.).

Required transformer power:

$$S_{TR} = \frac{P_{DC} \times \sqrt{3 \times U_N}}{25,5}$$

S_{TR} = transformer power in VA
 P_{DC} = DC bus continuous power in W
 U_N = transformer output voltage in V

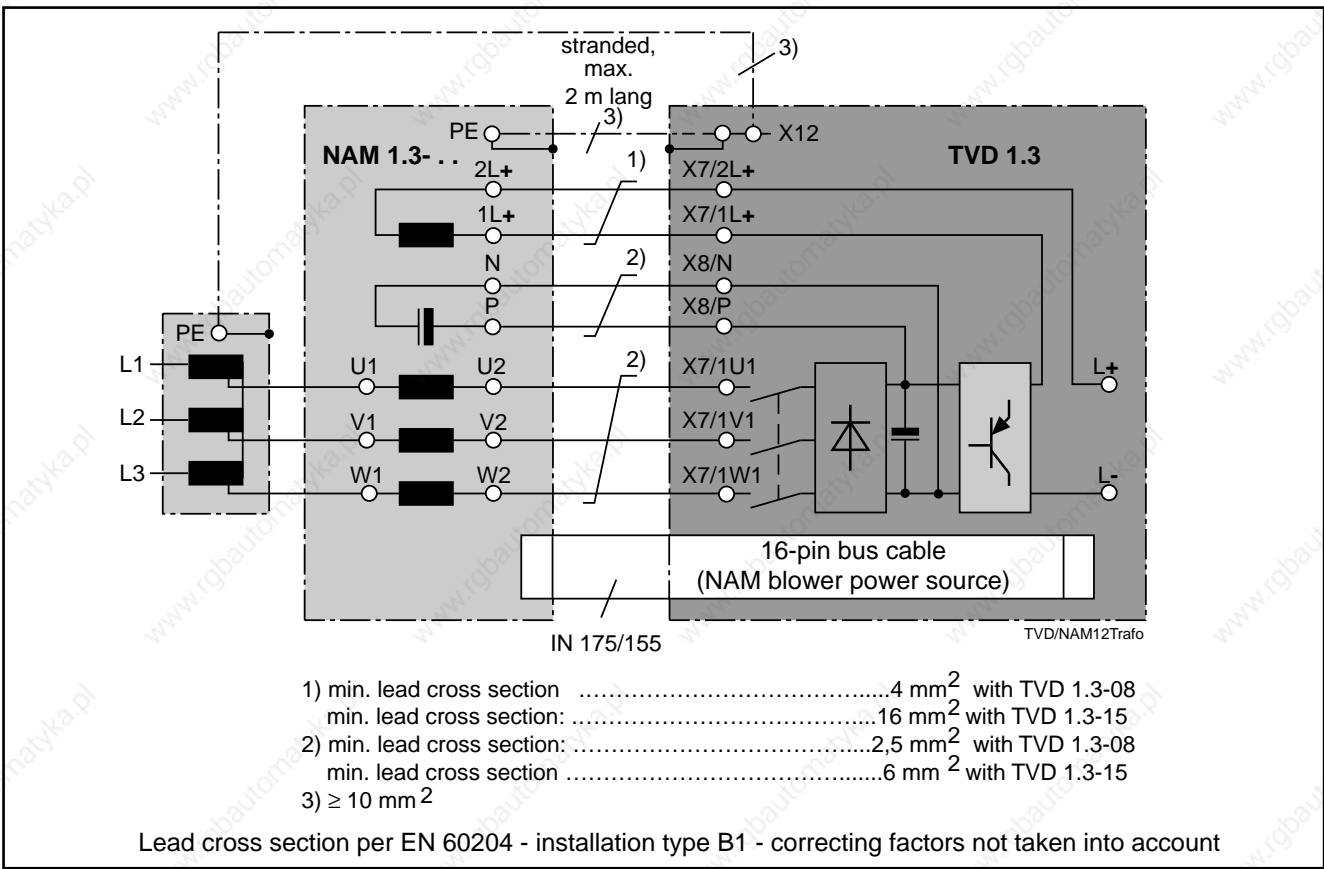

Fig. 3.6: Mains connection TVD 1.3 via a transformer

3.5. Fuse protection for direct mains connection

Protection for the mains input to the power section of the TVD 1.3 for direct connection to the mains can be effected by power circuit-breaker or with fusible links, utilization category gL.

Maximum fusing The fuse rating may not exceed 35 A.

The following recommendations are valid when circuit breakers are used for direct connection to mains.

If fuses are used, then fuses with utilization category gL can be used. Semiconductor fuses are not required. Select the fuses in terms of the mains current.

$$I_N = \frac{P_{DC}}{\sqrt{U_N} \cdot 25,5}$$

I_N = mains current in A
 P_{DC} = DC bus continuous power in W
 U_N = mains voltage in V

DC bus contin. power	Connected load at 380V	Mains current at		Power circuit breaker Siemens type	Adjust. current	Cross sect. of connected load lead ³⁾
		380V	480V			
7,5 kW	10 kVA	15 A	13.4 A	3VU1300-.MN00 ¹⁾	15 A	2.5 mm ²
15 kW	20 kVA	30 A	26.8 A	3VU1600-.MP00 ²⁾	30 A	6 mm ²

¹⁾ Max. back-up fuse as per manufacturer: 80 A (gL) for supply voltages up to 500 V
²⁾ Max. back-up fuse as per manufacturer: 200 A (gL) for supply voltages up to 500 V
³⁾ Lead cross section per EN60204 - installation type B1 - without taking correction factor into account

Fig. 3.7: Recommended fusing for the mains supply conductors

3.6. Mains supply earthing requirements

Earthed three-phase mains

The TVD 1.3 can be connected to a grounded wye or delta system without potential isolation.

Unearthed three-phase mains

For ungrounded three-phase mains supplies (IT mains) there exists the increased danger that overvoltages that are not permissible can occur between the phases and the housing. The TVD 1.3 can be protected against overvoltages

- if it is connected via an isolation transformer (connect the neutral point of the transformer to the TVD with a PE rail) or
- if the machine is protected by overvoltage detector.

Connecting the TVD 1.3 via an isolation transformer offers the best protection against overvoltage and the greatest possible operating safety.

- Overvoltages**
- The periodic overvoltage on the TVD 1.3 between a phase (1U1, 1V1, 1W1, 2U1, 2V1, 2W1) and the housing may not exceed 1000 V (peak value).
 - Non-periodic overvoltages, as per VDE 0160, between the phases and the phases and the housing are permissible for the TVD 1.3 as depicted in the diagram below.

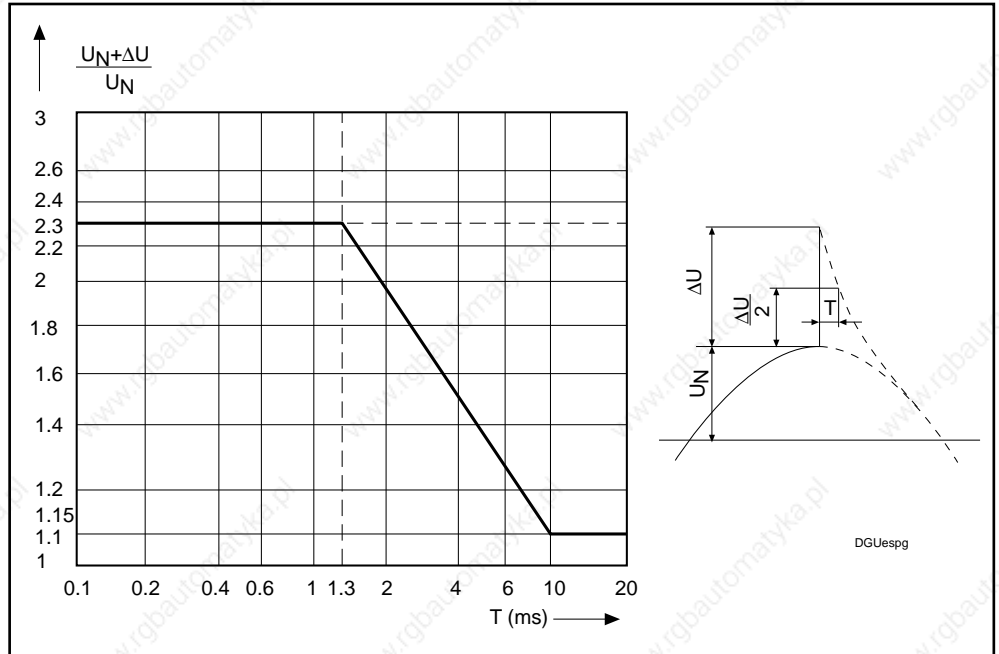

Fig. 3.8: Permissible non-periodic overvoltages as per VDE 0160

The TVD 1.3 can be connected to 3 x 480 V.

This means that the maximum permissible overvoltage equals:

$$480 \text{ V} \times \sqrt{2} \cdot 2.3 = 1560 \text{ V}$$

3.7. Commutation choke

In an effort to keep system perturbations as low as possible, the TVD should always be operated with a commutation choke. See sections 3.3 and 3.4; for power loss see dimension sheet in section 7.

3.8. DC bus circuit

Use the busbars contained in the connection accessories kit to connect the drive modules to the TVD's DC bus circuit.

Use twisted single conductors for longer connections (maximum length equals 1 meter).

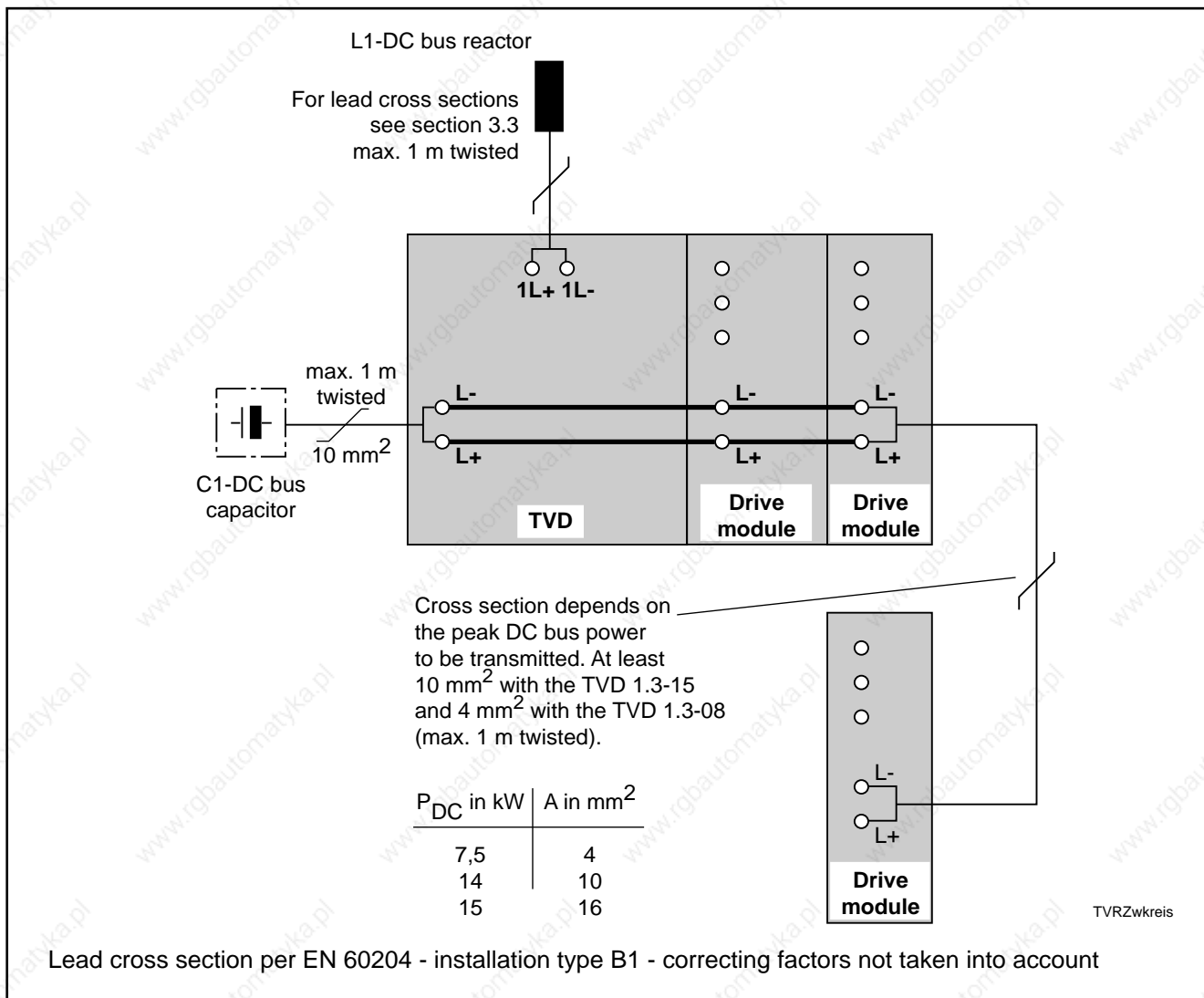

Fig. 3.9: Wiring the DC bus circuit

3.9. DC bus smoothing choke

The TVD 1.3 must **always** be operated with a DC bus smoothing choke in the "L+ line".

Supply Module	DC bus smoothing choke
TVD 1.3-08-3 TVD 1.3-15-3	GLD 16 (or NAM 1.3-08) GLD 17 (or NAM 1.3-15)

(See Section 3.3, for power loss see dimension sheet in section 7).

3.10. Additional DC bus capacitance

In plants where feed axes have to be accelerated and braked in rapid succession, e.g., nipple machines, surface grinders, roll feeds, and so on, the bleeder power and thus the power dissipation can be reduced by fitting additional capacitors to the link circuit.

In a few applications, it is necessary to initiate a return of the drives with a mains failure or an E-stop. The energy stored in the DC bus circuit can be used for the return. The energy stored in the DC bus circuit can be increased by additional capacitance.

Module	Maximum additional capacitance
TVD 1.3-08 TVD 1.3-15	$C_{max} = 70 \text{ mF}$ $C_{max} = 120 \text{ mF}$

3.11. Bridge circuit capacitance

In an effort to keep system perturbations as low as possible, the TVD must always be operated with the NAM mains connection module or the bridge capacitance CZ 1.2-01-7. See section 3.3. for details.

3.12. Additional bleeder module TBM

The TVD 1.3 can be operated with an additional bleeder module of the TBM 1.2 type. The TVD and TBM combination gives the following power data:

Supply module	Additional bleeder module	(1) P_{BD} kW	(2) P_{BM} KW	(3) W_{max} kWs
TVD 1.3-08	TBM 1.2-040-W1	1.5	60	130
TVD 1.3-15	TBM 1.2-040-W1	2.0	80	160

(1) P_{BD} = Continuous bleeder power
 (2) P_{BM} = Peak bleeder power
 (3) W_{max} = Maximum regenerated energy



Caution !

In a worst case scenario, the sum of the peak regenerated power of all simultaneously braking servo drives may not exceed the peak bleeder power of the supply module. If such is not taken into account during system design, then it is possible that the DC bus voltage during an E-stop could climb to high to the point where the drive equipment could be damaged.

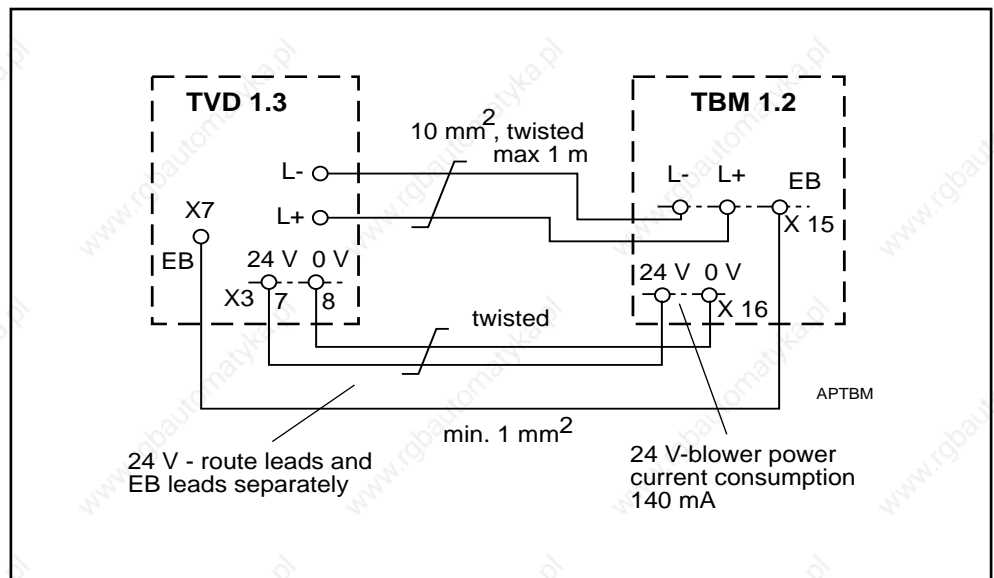

Fig. 3.10: Connecting the additional bleeder module TBM 1.2

3.13. External bleeder resistor

Terminal block: X7/RB1/RB2

To reduce the amount of heat dissipated in the control cabinet, an external bleeder resistor can be connected. This is installed outside the cabinet, e.g., on the rear panel of the cabinet. The bleeder resistor inside the TVD 1.3 is then inoperative.



Caution !

The voltage across the resistor can reach 450V DC.

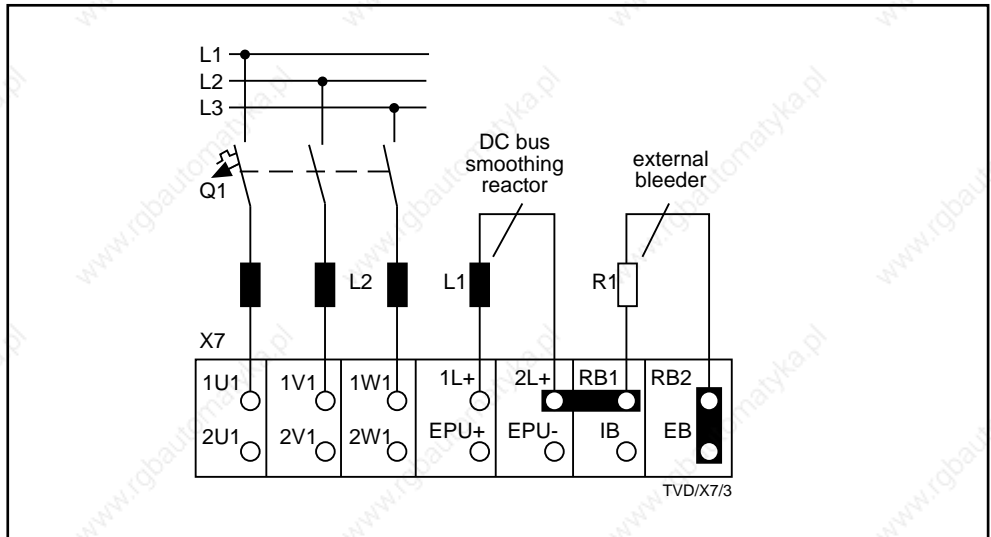

Fig. 3.11: Terminal block X7 when operating the TVD 1.3 with an external bleeder

Resistors can be used as indicated in the specification below:

Supply module:	TVD 1.3-08	TVD 1.3-15
Resistance +/- 5%	R = 10 ohms	R = 5 ohms
Continuous power (at 45°C ambient temperature)	P = 1 kW	P = 2 kW
Peak power (for 1.5 s)	P _{peak} = 20 kW	P _{peak} = 40 kW
Maximum input power	U _{max} = 450V	
Protection category	Depends on installation site!	

3.14. Supply to electronics and blower

Electronics Supply voltage: 3 x AC 380...480V, 50...60 Hz
 Connected load: 300 VA (for maximum utilization of supply to electronics)

The mains connections for the supply to power and electronics sections are strapped when the unit is delivered. No additional mains connection is thus required for the electronics section.

If a separate supply for the electronics is needed, e.g., to store the TVD's diagnostic signals with mains disconnection, then the links between power and electronics section can be removed. Short-circuit protection need only be provided in the control cabinet for the connecting cable, e.g., miniature circuit-breaker 3 VU 1300 -.MF00, 0,6 ... 1A, Siemens. Tap off electronics power source between commutation choke and TVD.

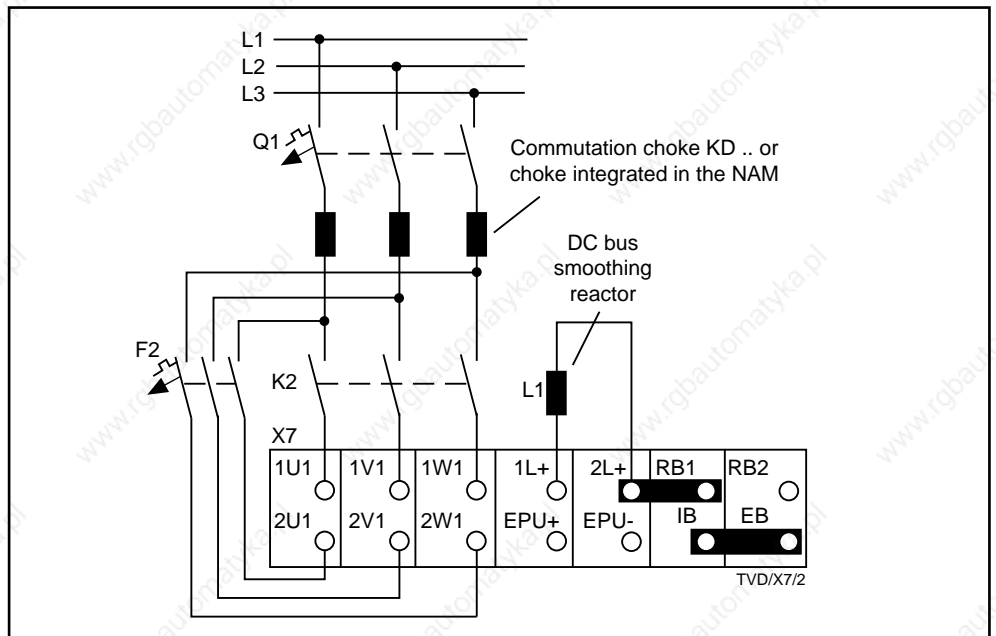

Fig. 3.12: Terminal block X7 for separate supplies to power and electronics sections

Blower The TVD 1.3 needs no additional mains connection for the blower. If drive modules are used that need a mains connection for cooling, this is done on the drive module next to the TVD 1.3. The mains connector for the blower supply must be ordered separately. The order number for the socket is 219 118.

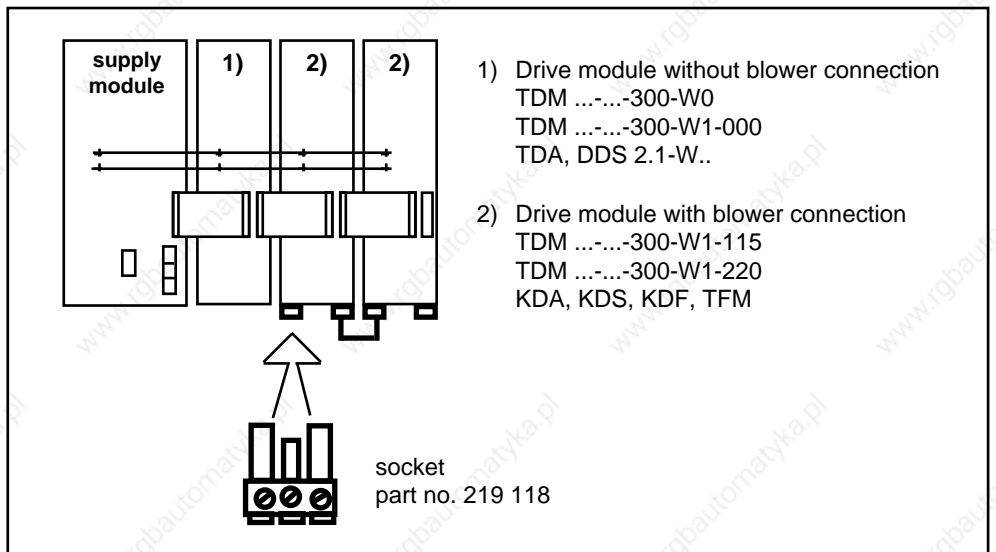

Fig. 3.13: Blower connections of the drive module

3.15. Electronics supply buffer capacitance

Terminal block: X7/EPU+/EPU-
Conductor cross section: 1 mm²

Additional electronic storage capacitance may be necessary if the drives have to be stopped under position control in the event of a mains failure.

A mains failure is signalled by the UD output. Following this, the NC controller must initiate controlled stopping of the drives within 10 ms, so that the drive electronics remain operational. If the elapsed time before the drives feed back power into the DC bus circuit exceeds 10 ms, then the user can boost the supply to the electronics by means of additional capacitors.

An aluminium electrolytic capacitor is recommended due to the limited space.



Caution !

**The voltage between EPU+ and EPU- can reach 450V DC. The capacitor must therefore be rated for this voltage.
A maximum of 680 µF may be connected otherwise the TVD 1.3 could be damaged.**

Back-up time	Storage capacitance (for maximum utilization of supply to electronics)
20 ms	150 µF
50 ms	270 µF
100 ms	680 µF

3.16. Electronics supply and signal exchange connections

Terminal connection X1 has two functions:

- voltage source to the drive electronics and
- signal exchange between supply and drive module(s)

The wire ribbon cable on the TVD 1.3 side has 16 pins. It is included in the electrical connecting accessories of the drive module.

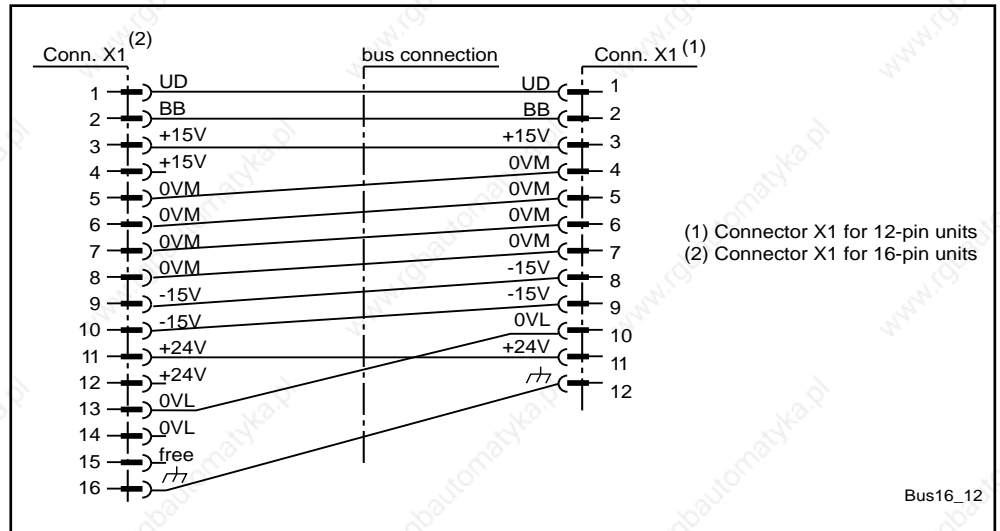

Fig. 3.14: Transition from 16-pin bus connector to 12-pin bus connector

The wire ribbon connection is completed with a terminating plug for verifying the wiring. Without it, the high voltage section cannot be powered up. The TVD 1.3 can also be installed in the middle of the drive package. In this case, it suffices if one end of the wire ribbon is terminated.

The terminating plug is part of the connecting accessories of the supply module.

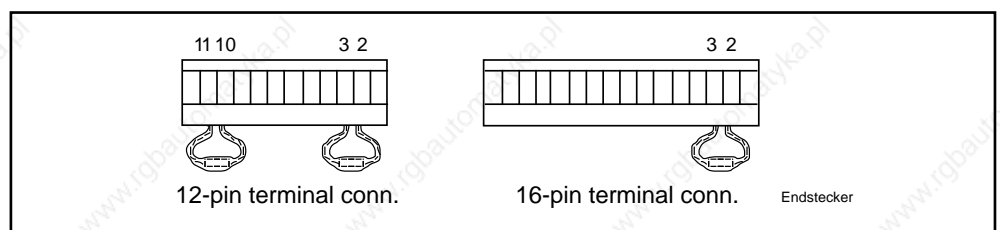

Fig. 3.15: End plug for terminating the bus connection

3.17. Residual current operated devices

A current circuit breaker (fuse or power circuit breaker) should preferably be used to switch power off in the event of a short-circuit to the housing (ground). If **TT systems** absolutely necessitate a residual current operated device because of the size of the grounding resistance, then the following must be taken into account.

In the case of switched-mode drive controllers, capacitive leakage currents always flow to ground.

The degree of the leakage current depends on

- the number of drive controllers used,
- the length of the motor power cable and
- the grounding conditions on site.

The leakage current inevitably rises if steps are taken to improve the electromagnetic compatibility of the machine (mains filter or shielded conductors). **Do not** use residual current operated devices with leakage currents of less than 0.3A!



False tripping can occur when switching inductances and capacitances on (rf interference suppression filters, transformers, contactors and magnetic valves).



Warning!

Commercial pulse-sensitive residual current operated devices (unit designation ) do not guarantee that electronic equipment with a three-phase bridge circuit (B6 circuit) is sufficiently protected. The protection of the electrical equipment connected to such devices together with equipment with B6 circuits can be impaired.

Either residual current operated devices which switch off also with DC-leakage current should be used, or an isolation transformer should be placed in the mains supply line.

If isolation transformers are used, then the overcurrent protective devices must be tuned to the impedance of the ground fault loop so that there is an immediate tripping in the event of a fault. Connect the star point of the secondary windings to the protective conductor of the machine.

3.18. Control cabinet testing



No voltages other than those specified in the data sheet or in the interface notes should be connected.

Prior to a high voltage test of the control cabinet, disconnect all connections from the TVR.

3.19. Mounting the TVD 1.3 into the control cabinet

Installation requirements

The power supply module and its associated drive modules are designed to be installed in a control cabinet or a closed housing. They correspond to protection classification IP 10, as per DIN 40 050.

The unit is protected from penetration of solid, foreign matter with a diameter greater than 50 mm.

The unit is not protected against

- the admission of water or
- intentional access, for example, a touch of the hand. However, it does keep flat surfaces away.

Arranging the drives

Arrange the drives so that the one requiring the greatest power and current is as near as possible to the power supply.

Maximum number of drives

With 12 pin bus connections there can be no more than a total of 16, viz., eight to the left and eight to the right.

With 16 pin bus connections there can be no more than a total of 20, viz., ten to the left and ten to the right.

The maximum load of the +24 V and ± 15 V may not be exceeded.

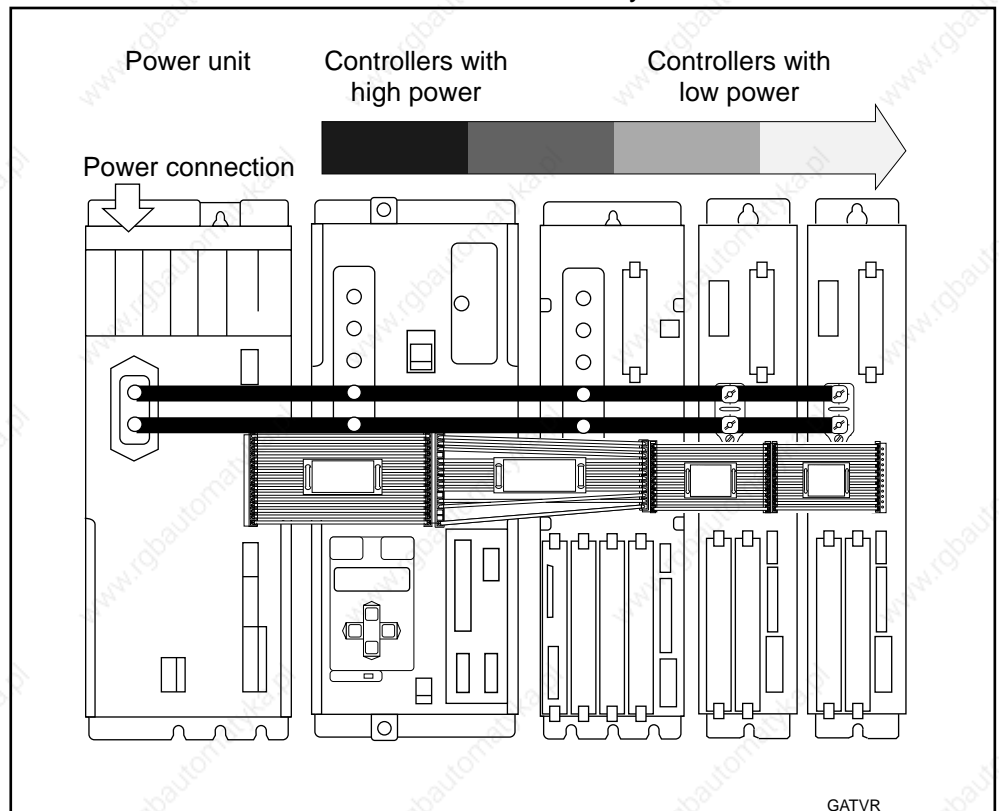

Fig. 3.16: Preferred arrangement of the units inside the control cabinet

Spacing dimensions in the control cabinet

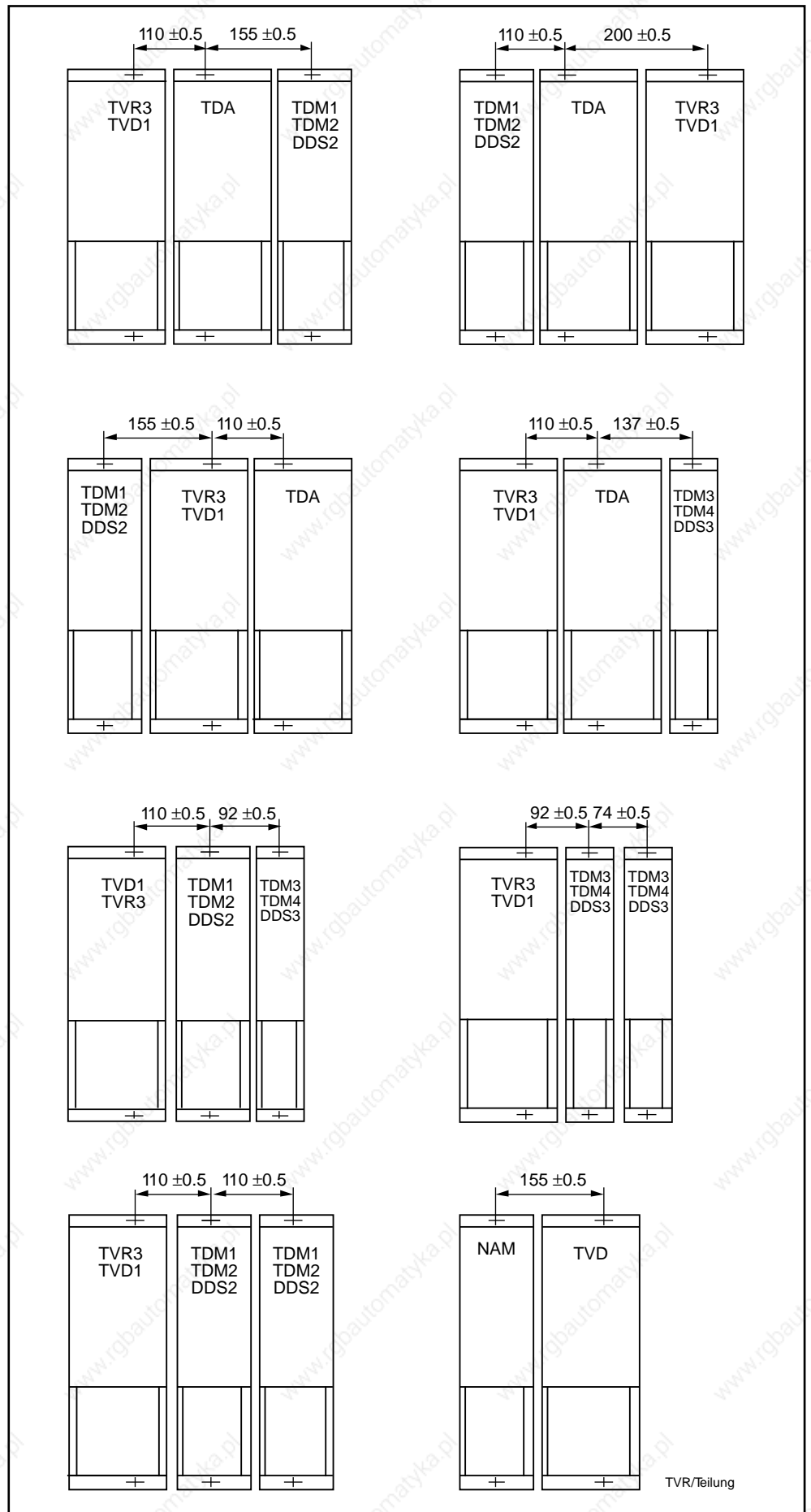

Fig. 3.17: Spacing dimensions in the control cabinet

3.20. Heat loss inside the control cabinet

Basic losses in the TVD 1. 3 occur as a result of the generation of signal voltages and high voltage power.

- Basic losses** Basic losses equal 75 W.
- Power losses** 14 W per kW of DC bus continuous power in the TVD 1.3-08
17 W per kW of DC bus continuous power in the TVD 1.3-15
- Bleeder losses** Bleeder losses are dependent upon the rotary drive energy, the potential energy of imbalanced masses and the machine cycle in progress.

$$P_{RD} = \frac{W_{rotg} + W_{potg}}{t_z}$$

- P_{RD} = regenerated continuous power or bleeder continuous power in kW
 t_z = cycle time in s
 W_{potg} = sum of the potential energies in kW
 W_{rotg} = sum of the rotary energies in kW



Especially when running main drives (2AD; 1MB) check to make sure that the continuous bleeder power and the maximum regenerated energy do not exceed the values as listed in the data sheets.

3.21. Safety clearance inside the control cabinet

The bleeder resistor in the TVD 1.3 is hot after power is shut down. Flammable materials such as cables and cable channels must be kept at a distance of at least 300 mm above and 40 mm to the side and to the front of the bleeder resistor.

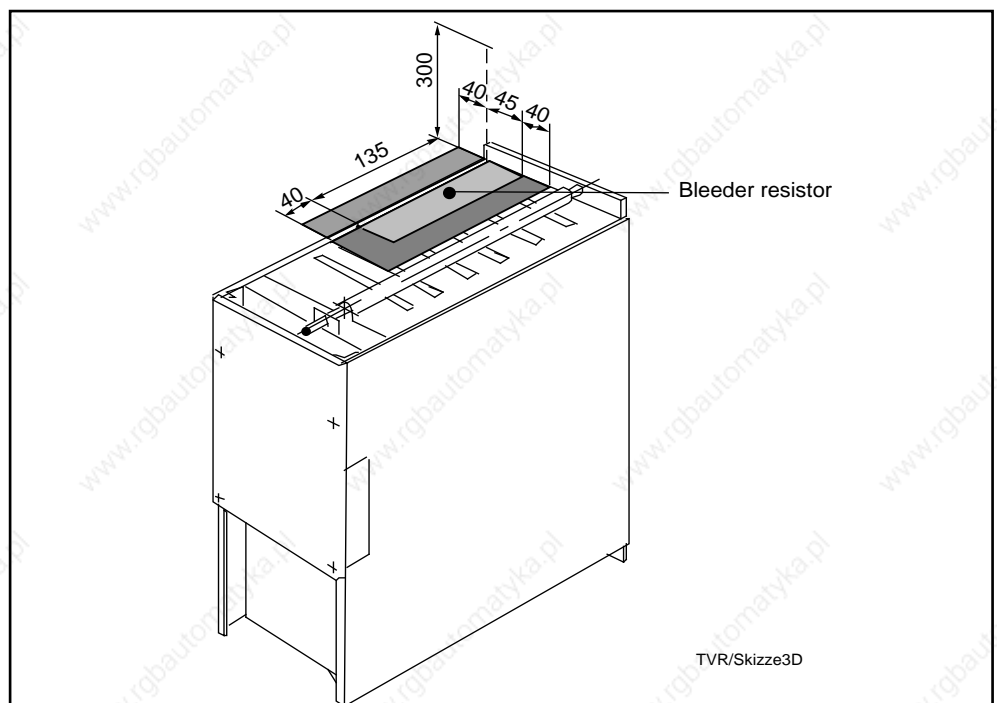

Fig. 3.18: Safety clearances inside the control cabinet

3.22. Front view of the TVD 1.3

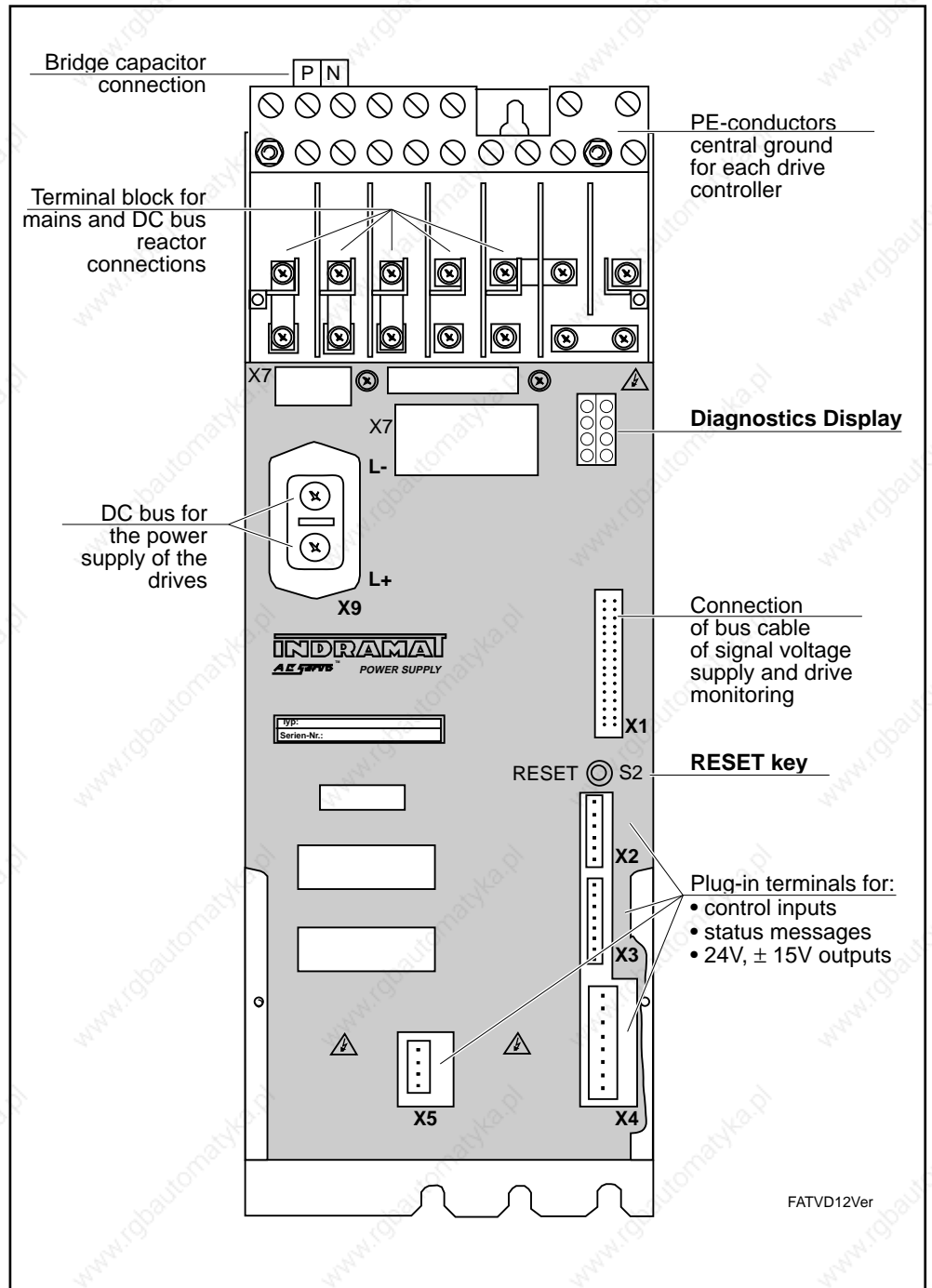

Fig. 3.19: Front view of supply module TVD 1.3

4. TVD 1.3 Interconnections

The interconnections for mains and the DC bus of the TVD recommended by INDRAMAT illustrate the operating principles of the unit. This section outlines several interconnect configurations. Just which configuration is selected depends on the functions and the sequence of actions required for the entire machine and is the responsibility of the machine builder.

4.1. Optional Control Possibilities

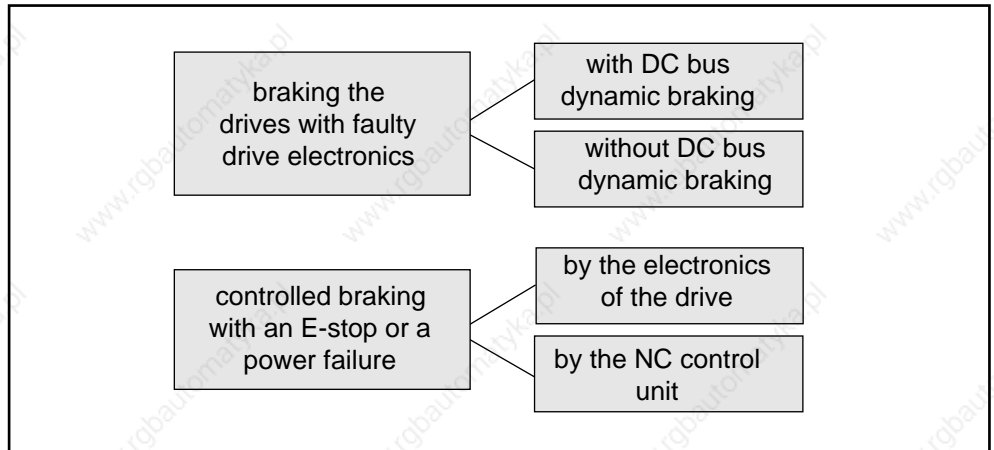

Fig. 4.1: Optional control possibilities

Stopping the drives with faulty drive electronics with or without DC dynamic braking

The DC bus is short-circuited for braking the drives to a standstill as an additional safety precaution if there is ever a fault in the drive electronics.

With DC bus dynamic braking, synchronous motors are always braked to a standstill regardless of whether the drive electronics are functional or not.

Without DC bus dynamic braking, synchronous motors can not be braked with faulty drive electronics.

Asynchronous motors cannot be braked if the DC bus is short-circuited!

Braking with an E-stop or mains failure at maximum torque by the drive electronics or in a position loop by the NC control unit

Drives are generally brought to a standstill by the drive control with an E-stop or mains failure.

In the event of an E-stop or if the drive-internal monitors are tripped, then drive control switches to zero command value and there is a regulated braking of the drives at maximum torque.

In some cases (e.g., electronically coupled tooth gear machines), it may be necessary for the CNC to bring the drives to a standstill in an E-stop situation or a mains failure.

There is then a regulated braking of the drives by the NC control unit with an E-stop or if the drive-internal monitors are tripped.

4.2. TVD interconnect with DC bus dynamic braking

With this variant, a high level of safety with a **low level of expenditure** is achieved. The monitoring devices built into the drive system are used most effectively, in this case:

- Application**
- if the TVD 1.3 is supplying feed drives only
 - and if asynchronous spindle drives and synchronous feed drives are operated from the same TVD.

Features **The NCB link on the TVD (X3/1 - X3/2) must not be jumpered.**

It is possible to brake synchronous motors (permanently excited) with the DC bus dynamic brakes whether the drive electronics are operational or not. DC bus dynamic braking occurs **only if there is a fault** in the drive. Therefore, if the E-stop button is pressed, asynchronous drives are also braked.

If there is an E-stop or one of the monitor circuits of the TVD is tripped, for example, by a power failure, then the drives are braked at maximum torque under **drive electronic regulation**.



Source of danger:

The DC bus dynamic brake protects machines in the event of drive failure. It alone does not function to protect personnel. In the event of faults in the drive and the supply module, uncontrolled drive movements are still possible even if the DC bus dynamic brake (X2/2 = 0) is activated.

Possible cauess:

Injury to personnel is possible depending upon the type of machine.

How to avoid:

Additional monitoring and safety devices can be installed on the machine side.

Mode of operation When the E-stop button is pressed, the main contactor in the TVD 1.3 drops out immediately. The drive enable signal of the drives is dropped by means of an auxiliary contact of the main contactor. This leads to a drive-internal switching of the velocity command to zero in all drives in the drive packet. All drives are braked under control.

A drive fault signal to the supply module (Bb1 contact), a fault signal from the NC (servo fault), or an overtravelling of the limit switch cause the main contactor to be switched off and the DC bus dynamic brake to be applied.

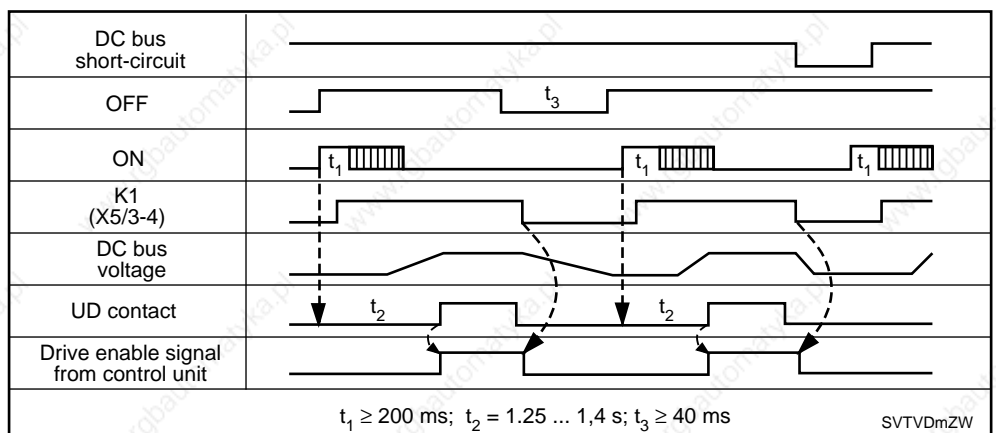

Fig. 4.2: Path of the signal when powering up the TVD

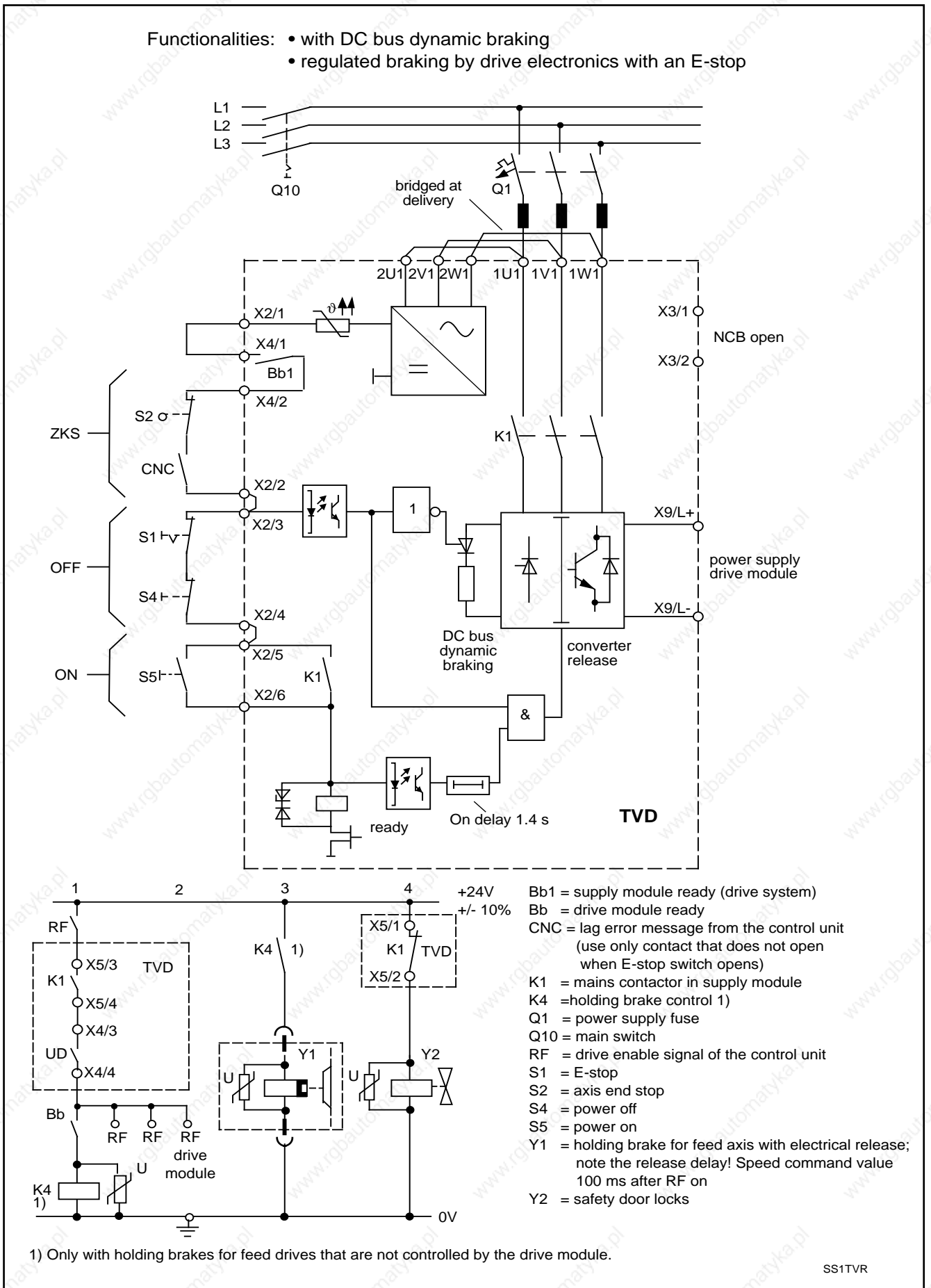

Fig. 4.3: Controlling the TVD 1.3 with DC bus dynamic brake

4.3. TVD interconnect with E-stop relay with DC bus dynamic braking

Excellent safety at **low cost** is achieved with this variant. The monitoring devices built into the drive system are used most effectively.

- Application**
- in larger plants where monitoring or numerous E-stop switches are required,
 - if the TVD is supplying feed drives only and
 - if synchronous and inductance drives are operated from the same TVD.

Features **The NCB link on the TVD (X3/1 - X3/2) may not be jumpered.**
 DC bus dynamic braking always brakes synchronous motors to a controlled standstill regardless of whether the drive electronics are still functioning or not. DC bus is short-circuited only if there is a **fault in the drives**. If the E-stop relay is switched off, then inductance main drives can be braked as well.

If there is an E-stop or one of the monitor circuits of the TVD is tripped, for example, with a power failure, the drives are braked at maximum torque under **drive regulation**.



Warning!

Source of danger:
The DC bus dynamic brake protects machines in the event of drive failure. It alone does not function to protect personnel. In the event of faults in the drive and the supply module, uncontrolled drive movements are still possible even if the DC bus dynamic brake (X2/2 = 0) is activated.

Possible cauess:
Injury to personnel is possible depending upon the type of machine.

How to avoid:
Additional monitoring and safety devices can be installed on the machine side.

Mode of operation When the E-stop button is pressed, the main contactor in the TVD drops out immediately. The enable signal of the drives is dropped by means of an auxiliary contact of the main contactor. This leads to a drive-internal switching of the velocity command to zero in all drives in the drive packet. All drives are braked under control.

A drive fault signal to the TVD 1.3 (Bb1 contact), a fault signal from the NC (servo fault), or an overtravel signal from the overtravel limit switch cause the main contactor to be switched off and the DC bus dynamic brake to be applied.

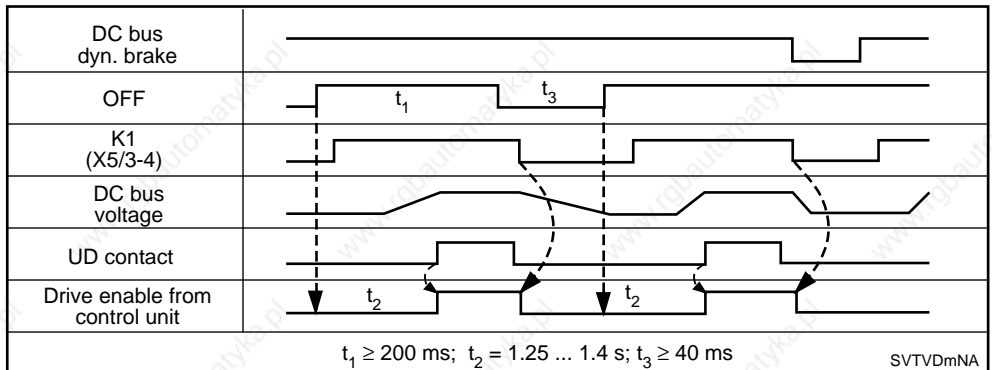

Fig. 4.4: Signal path when powering up a TVD

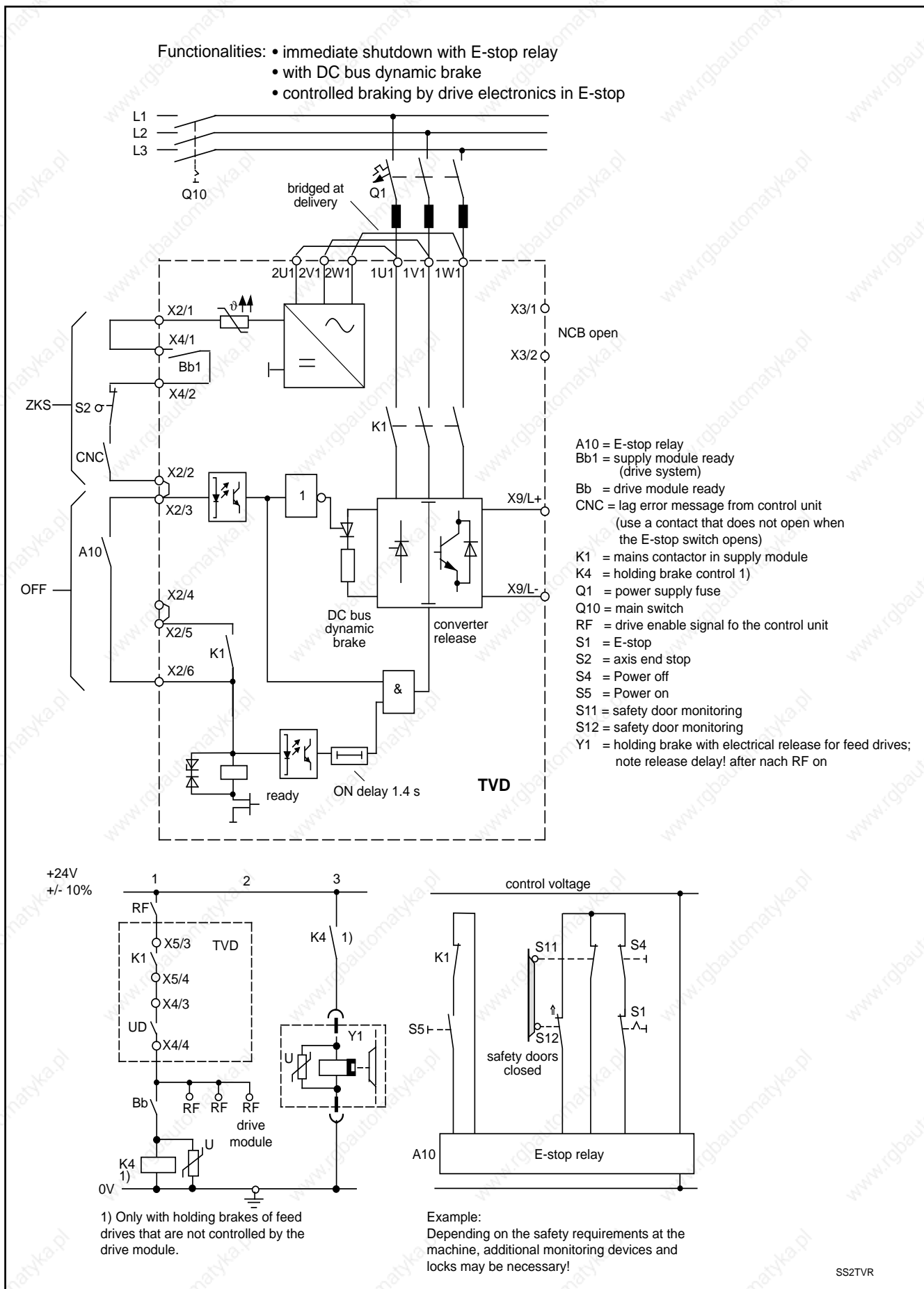

Fig. 4.5: TVD 1.3 interconnect with DC bus dynamic braking

4.4. TVD interconnect without DC bus dynamic braking

Application If the uncontrolled coasting of the drives cannot damage the plant.

Typical applications

- if the TVD supplies inductance drives only and
- if the end-stops of the feed axes are sufficiently damped.

Features **The NCB link on the TVD (X3/1 - X3/2) may not be jumpered.** The DC bus voltage is **not short-circuited**. In the case of inductance drives, the DC bus dynamic brake has no additional braking effect when there is a fault in the drive electronics. If the DC bus is short-circuited, inductance drives can no longer be braked under drive control.

With an E-stop or if one of the monitoring circuits of the TVD is tripped, e.g., as a result of a power failure, then the drives are braked at maximum torque under **drive regulation**.

Mode of operation When the E-stop key is pressed, the main contactor in the TVD drops out immediately. The drive enable signal of the drives is dropped by means of an auxiliary contact of the main contactor. This leads to a drive-internal switching of the velocity command to zero in all drives in th drive packet. All drives are braked under control.



Source of danger:
Coasting of the drives with faulty drive electronics.

Possible consequences:
Machine damage.

How to avoid:

- **End stops of feed axes must be sufficiently damped.**
- **Use motors with mechanical brakes.**

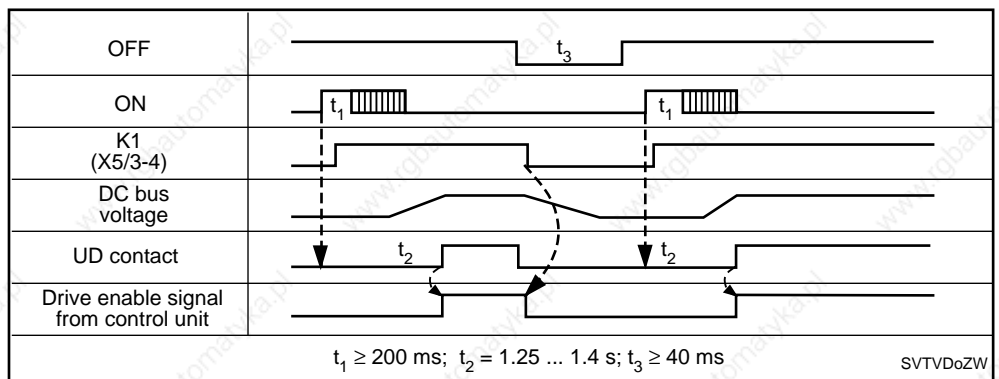
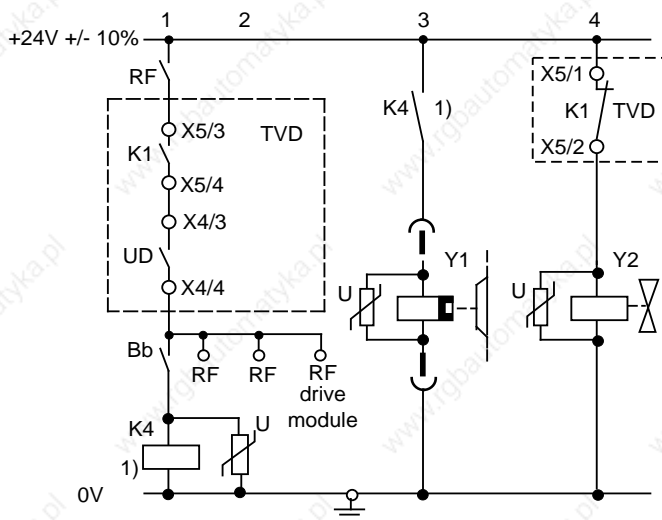
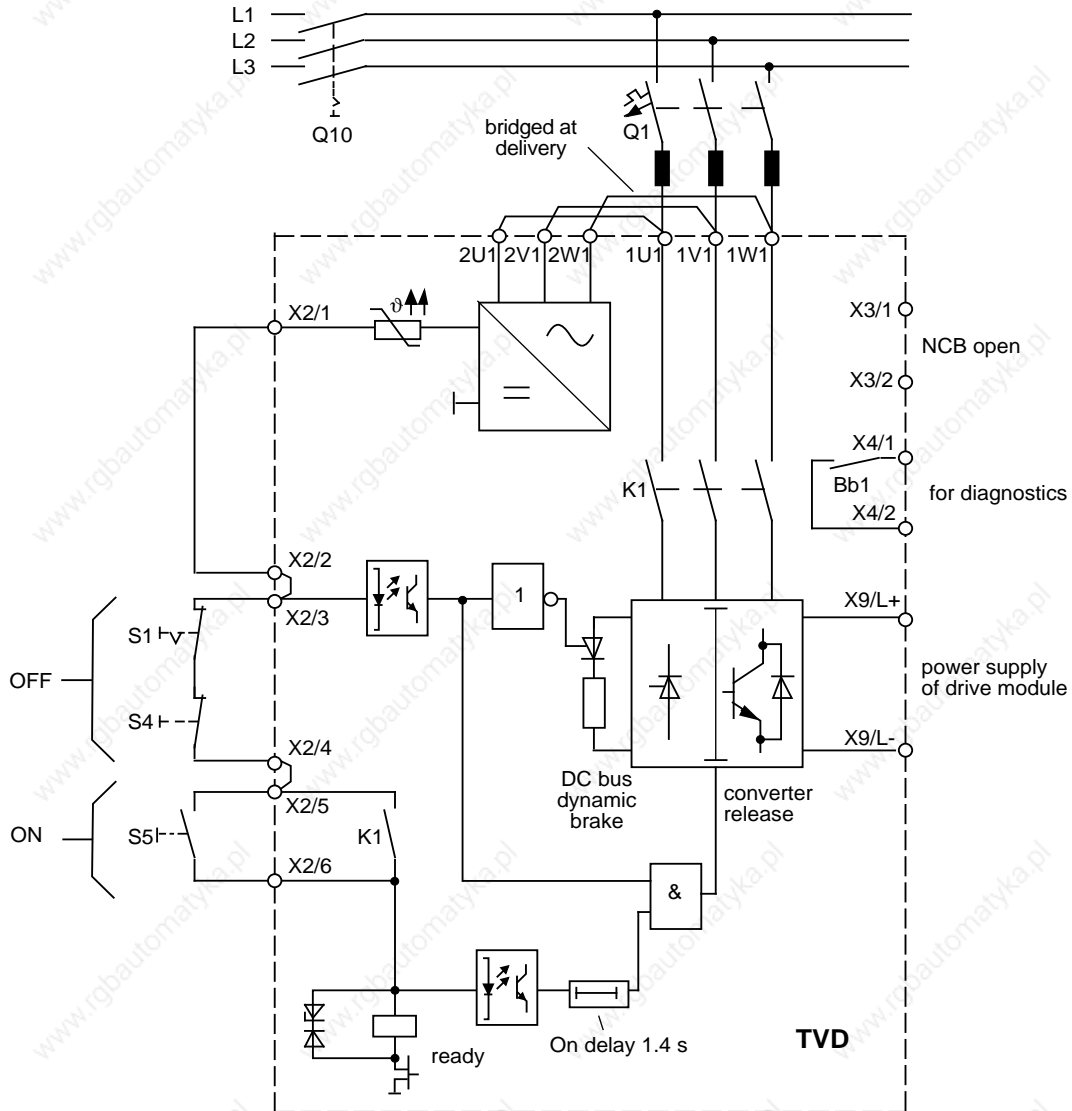

Fig.4.6: Signal path when powering up the TVD

- Functionalities:
- without DC bus dynamic brake
 - controlled braking by the drive electronics in E-stop



- Bb1 = supply module ready (drive system)
- Bb = drive module ready
- K1 = mains contactor in supply module
- K4 = holding brake control 1)
- Q1 = power supply fuse
- Q10 = main switch
- RF = drive enable signal of the control unit
- S1 = E-stop
- S4 = power off
- S5 = power on
- Y1 = holding brake for feed axis with electrical release; note the release delay! Speed command value 100 ms after RF on
- Y2 = safety door locks

1) Only with holding brakes for feed drives that are not controlled by the drive module.

SSTVR/3

Fig. 4.7: TVD interconnect without DC bus dynamic braking

4.5. TVD interconnect for a position-controlled braking of the drives

Application Drives which are coupled electronically as if by gearboxes under the control of an NC cannot normally accept an angular positioning error in the event of a power failure.

Features **The NCB link on the TVD (X3/1 - X3/2) must be jumpered. The mains contactor may not switch the drive enable signal off.**
 The DC bus voltage is **not short-circuited** so that energy is available for a position-controlled stopping of the drives.

During E-stop or if one of the monitor circuits of the TVD, e.g., during a power failure, is tripped, then the drives will be brought to a standstill under **position-control** through the NC.

The energy stored in or regenerated to the DC bus circuit must be greater than the energy required to excite the inductance machines or for return movements.

Mode of operation When the E-stop chain opens, the main contactor in the TVD drops out immediately. The NC must bring the drives to a stop under position control.



Source of danger:
A faulty power supply is not signalled to the drives when the NCB link is installed.

Possible consequences:
There is an uncontrolled braking of the drives with a power failure. The degree of damage depends upon the type of machine.

How to avoid:
If the UD contact opens, then the NC must bring the drives to a position-controlled standstill.

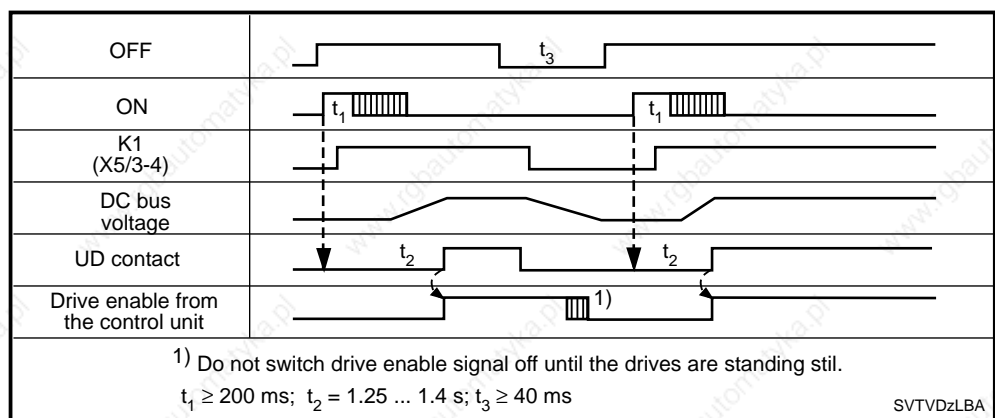
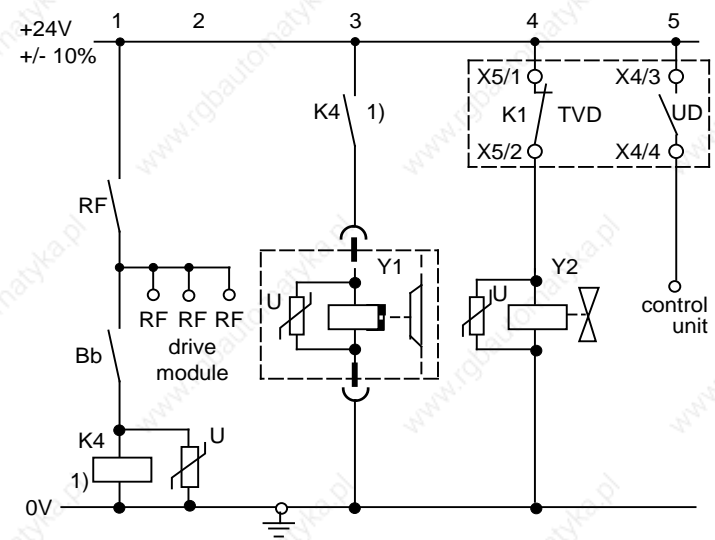
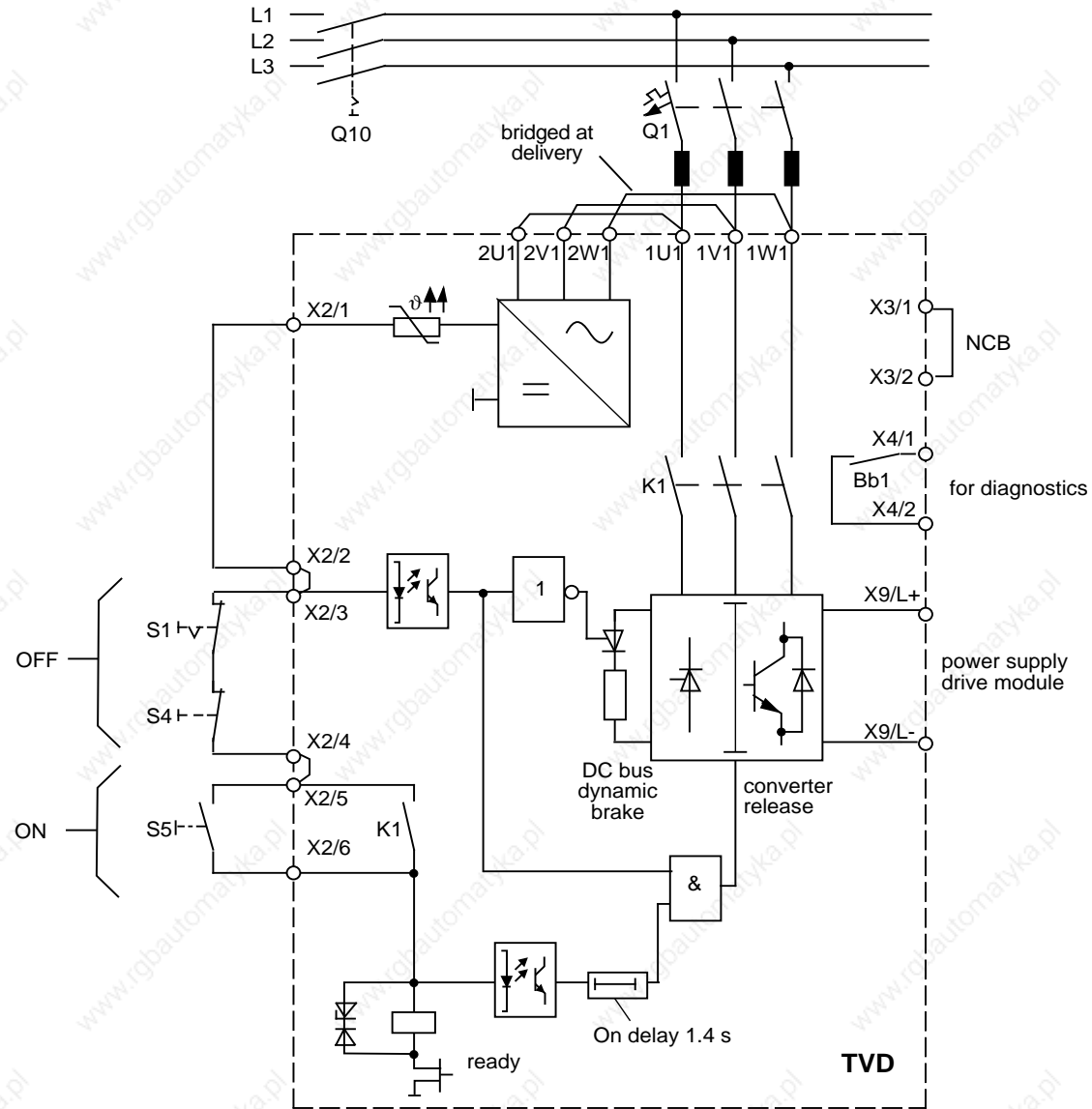

Fig. 4.8: Signal path when switching on a TVD

- Functionalities:
- without DC bus dynamic brake
 - controlled braking by the NC control unit in E-stop



- Bb1 = supply module ready (drive system)
- Bb = drive module ready
- K1 = mains contactor in supply module
- K4 = holding brake control 1)
- Q1 = power supply fuse
- Q10 = main switch
- RF = drive enable signal of the control unit
- S1 = E-stop
- S2 = axis end stop
- S4 = power off
- S5 = power on
- UD = signal from KVR; power feed working
- Y1 = holding brake for feed axis with electrical release; note the release delay! Speed command value 100 ms after RF on
- Y2 = safety door locks

1) Only with holding brakes for feed drives that are not controlled by the drive module.

SS4TVR

Fig. 4.9: Control of the TVD for a position-controlled braking of the drives

5. Terminal Descriptions

5.1. DC bus short-circuiting

Terminal X2/1 - X2/2

Input ZKS Voltage: 24 V DC Current consumption: 270 mA

Input	open	closed
Operating status	Power off, DC bus short-circuit closed	Power on, DC bus short-circuit open

The TVD main power contactor can be pulled in only if the ZKS input is closed. The DC bus is short-circuited if the ZKS input is open. This is an additional safety feature for the machine for braking drives to a standstill with a fault in drive electronics.

Switching rate Maximum of 25 operating cycles per minute (w/o additional capacitance with drive standing)

$$Z = \frac{2 \cdot P_{ZK}}{C_{zu} \cdot 425^2 + J_g \cdot \omega^2} \cdot 60$$

C_{zu} = DC bus capacitance in F
 J_g = Total moment of inertia of mass in kgm²
 P_{ZK} = Power of the ZK resistor in W
 220W with TVD 1.3-08
 440W with TVD 1.3-15
 ω = Angular speed in rad / s
 Z = Switching rate per minute but max. 25 / min.

Fig. 5.1: Switching rate with additional capacitance and rotating motor

5.2. Power off

Terminal X2/3 - X2/4

Input OFF Voltage: 24 V DC Current consumption: 270 mA

Input	open	closed
Operating status	Power off	Power on

The main power contactor in the TVD can be pulled in only if the OFF input is closed. If the OFF input is open, for example during an E-stop, then the main power contactor in the TVD opens immediately.

5.3. Power on

Terminal X2/5 - X2/6

Input ON Voltage: 24 V DC Current consumption: 270 mA

Input	open	closed or open and closed when latched
Operating status	Power off	Power on

If ZKS and OFF inputs are closed and the internal drive-ready signal is present, closing the ON input will cause the TVD main contactor to pull in. Next, the main contactor is latched on. The ON signal is a pulse and must hold high for at least 200 ms.

Switching rate: max. 25 operating cycles per minute
 Service life: 2.5 million operating cycles

5.4. Stopping the drives in an E-stop or a power failure

NCB Link Input – Terminal X3/1 - X3/2

jumper	open	closed
controlled braking with an E-stop or a power failure	by the drive electronics	by the NC control

If the NCB link is open or not jumpered, a power failure or a drive fault in the drive system is signalled to all the drives. The drives are braked at maximum torque. In addition, if there is a drive fault, the internal ready signal of the TVD is dropped which leads to shutdown of the power supply.

In some applications, for example, electronically coupled gear cutting machines, the drives have to be braked position-controlled through the CNC if there is an E-stop or a power failure.



Do not use the NCB link for digital drives with SERCOS interface. Position-controlled braking is done without the NCB link by programming the fault reaction directly into the drive. The NCB link prevents the signalling of a faulty power supply to the drive.

With the NCB jumpered, the following faults are not signalled to the drives:

- Faulty power supply
 - mains power failure / missing phase
 - DC bus voltage less than 270 V
- Drive faults
 - open wire-ribbon connection or missing terminating connector
 - low-voltage faults +24 VL/±15 VM
 - overcurrent in the TVD high-voltage section
 - bleeder overload
 - overtemperature in the TVD heatsink

Because these monitor circuits are not tripped, the drives can be braked to a standstill under position control if there is a power failure. The power regenerated during braking must be greater than the power consumption of the TVD.

The power supply of the TVD is always switched off by the internal "ready" signal in the presence of a drive fault.



Caution !

Source of danger:

With the NCB link closed or jumpered, the command to zero of the drives is suppressed.

Possible consequences:

The drives can coast uncontrolled. Damage to the machine depends upon the type of machine.

How to avoid:

The CNC control must evaluate the UD contact and bring the drives to a standstill when this contact is open.

5.5. Signal Voltages

Signal voltages can be accessed on terminal strip X3. These terminals are designed for test and measurement purposes. If these voltages are used exterior to the TVD, ensure that no noise or interference is coupled in (short-connections, shielded leads, etc.).

The signal voltage outputs are short-circuit protected. To prevent damage to the drives, the maximum permissible loading must not be exceeded.

X3/3	+15VM	measuring voltage max.100 mA
X3/4	0VM	reference potential of measuring voltage
X3/5	-15VM	measuring voltage max.100 mA
X3/6	ground	shielding
X3/7	+24VL	load voltage max. 2 A
X3/8	0VL	reference potential load voltage

Output Bb1 5.6. "Ready" status

Potential free contact – terminal X4/1 - X4/2

Maximum load: DC 24 V/1 A; AC 250 V/1A

Operating status	Relay de-energized	Fault	ready
Output	open	open	closed

The Bb1 contact of the TVD is very important and has special significance. The Bb1 contact signals whether the drive packet is ready for switch on power. The TVD's internal interlocks will not permit the main contactor to pull in until Bb1 is closed.

If there is a fault, the main contactor drops out and the Bb1 contact opens. If Bb1 opens, controlled braking of the drives is no longer assured. Therefore it is used to trigger DC bus short-circuit.

Bb1 closes when power for electronics is applied to terminal block X7/2U1/2V1/2W1 and there is no fault.

Bb1 opens for the following faults:

- tachometer fault
- overtemperature in the drive
- overcurrent in the drive module
- signal voltage fault ± 15 VM / +24 VL
- an open in the wire-ribbon connection or missing wire-ribbon termination
- TVD heatsink temperature too high
- overcurrent in the TVD high-voltage section
- overvoltage
- bleeder overload

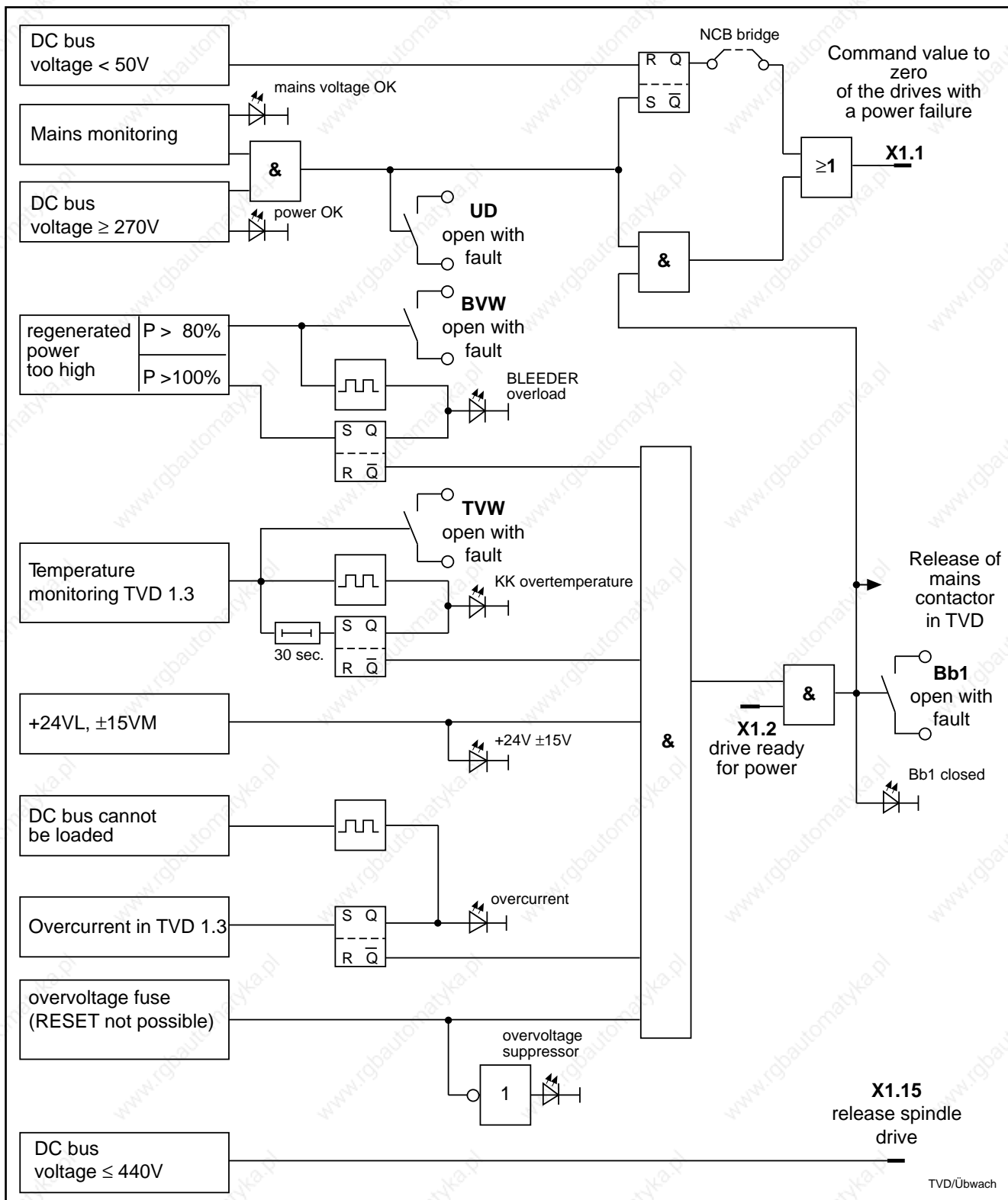

Fig. 5.2: Monitoring and diagnostics systems of the TVD 1.3

5.7. Power OK

Output UD Potential free contact – terminal X4/3 – X4/4

Maximum load: DC 24 V/1 A; AC 250 V/1A

Operating status	Relay de-energized	Fault	Power OK
Output	open	open	closed

The UD contact acknowledges proper operation of the power system.

UD opens for the following faults:

- mains power failure / missing phase
- DC bus voltage lower than 270 V

The reaction of the drive system to these faults depends on the NCB link. See section 5.4 for details.

If CNC-controlled braking is required, the drives must be stopped by the master controller when the UD contact opens.

5.8. Regenerated power too high

Output BVW Potential free contact – terminal X4/5 – X4/6

Maximum load: DC 24 V/1 A; AC 250 V/1A

Operating status	Relay de-energized	Regenerated power too high	Regenerated power within permissible limits
Output	open	open	closed

The bleeder prewarning contact opens if the regenerated continuous power is greater than the continuous bleeder power. If the bleeder load continues to climb and reach thermal overload, then the main contactor in the TVD interrupts the power supply and Bb1 opens.

The reaction of the drive system to this fault depends on the NCB link. See section 5.4 for details.

5.9. Temperature Pre-Warning

Output TVW Potential free contact – terminal X4/7 – X4/8
Maximum load: DC 24 V/1 A; AC 250 V/1A

Operating status	Relay de-energized	Temperature too high	Temperature within permissible limits
Output	open	open	closed

The temperature prewarn contact opens if the heatsink temperature is too high. After 30 seconds, the mains contactor in the TVD interrupts the power supply and the Bb1 contact opens.

The reaction of the drive system to this fault depends on the NCB link. See section 5.4 for details.

If CNC-controlled braking is required, the drives must be stopped within 30 seconds if a temperature pre-warning contact in the TVD or one of the drive modules opens.

5.10. Mains contactor de-energized

Output K1NC Potential free contact – terminal X5/1 – X5/2
Maximum load: DC 24 V/1 A / AC 250 V/1 A

Operating status	contactor de-energized	contactor energized
Output	closed	open

The K1NC output can be interrogated to see if the mains contactor is de-energized. This status can be used as a condition for enabling door interlocks, for example.

There is positively-driven operations between the K1NC and the main poles in the TVD 1.3.

5.11. Mains contactor energized

Output K1NO Potential free contact – Terminal X5/3 – X5/4
Maximum load: DC 24 V/1 A / AC 250 V/1 A

Operating status	contactor de-energized	contactor energized
Output	open	closed

The K1NO output can be interrogated to see if the mains contactor is energized. The closed status of K1NO can be used as a condition for the application of the enable signal to the drives. (Exception: see section 4.5.)

6. Troubleshooting

Long hours spent troubleshooting and repairing drive components on the machine are unacceptable because of production downtime.

INDRAMAT AC drive components can easily be replaced as entire units with no adjustment required because of their construction. This means that whenever there is a fault, servicing is reduced to localizing the problem to the motor, the power supply, or the drive module and then simply replacing the faulty component.

6.1. Localizing the fault

Faulty drive motions can be caused by interactions of various components, namely, the CNC, power supply to drive modules, mechanics, position measurement devices and so on. A fault in one of the above or their improper combination or tuning may be the source of the fault. The TVD 1.3 provides extensive diagnostics for rapid localization of faults.

There is an increased chance of an accident when a fault occurs. Personnel, machines and equipment are at risk.

Danger from voltage carrying parts

Dangerous voltage can occur at the following connections:

- At all connections to the power supply and its associated chokes and capacitors, and especially at connections to mains 1U1, 1V1, 1W1 and 2U1, 2V1, 2W1, as well as X13 und X14 of the blower.
- At the drive modules, motor and connections to the motor.



Danger !

Source of danger:

Electrical voltages of up to 700 V!

Possible consequences:

Danger to life and limb and property damage! Working on the range of energized components can lead to fatal injuries. This particularly applies to the supply modules and its related chokes, capacitors and fuses as well as drive modules, motor and motor connections.

How to avoid:

Only trained and qualified electrical personnel may be permitted to work on the machine.

Turn off all power to the installation for all work in the hazardous area. Lockout the installation so that power cannot be turned on.

Prior to starting work, use measuring devices to check whether the components of the machine are still energized (e.g., capacitors and so on). Wait the discharge time of the DC bus which is approximately five minutes!

Use only that measuring and testing equipment that is suitable and appropriate to the application.

Do not run motors. Voltage is present at the motor connections if the motor is in motion. Vertical axes must be secured against movement if the machine is switched off.

Insert protective caps into cables or open cable ends of power plug-in connectors when replacing drive components.

Do not power up until the all safety shrouds and devices for supply and drive modules are mounted back into place.

Danger from moving parts



Source of danger:

Unexpected and unintentional axis movements!

Possible consequences:

Danger to life and limb and property damage! Problems with the machine and when locating the problem represent, in particular, situations with an increased risk.

How to avoid:

Personnel must not remain in the hazardous area of the installation.

Protective devices such as safety screens, covers and light barriers must not be disabled. There must be free, ready and easy access to the E-stop button.

Replacing units

Required for replacement are:

- a lifting device (dependent upon the weight of the device to be replaced)
- and a replacement unit of the same type.

Please comply with the procedures below:

1. Shut the power to the machine off and secure the device against being unintentionally or accidentally switched back on.
2. Using suitable equipment, check whether the machine is not conducting electricity. Wait the discharge time. Motors must be standing still. Vertical axes must be secured against movement.
3. Using the rating plate, make sure that both units are the same. The replacement unit must be of the same type as the unit being replaced.
4. Release all connections of the defective unit.
5. Release the fixing screws and remove the unit from the control cabinet. Use the lifting device, e.g., a crane, if necessary.



Caution !

Source of danger:

Electrostatic discharges are possible!

Possible consequences:

The discharge could damage electronic components and equipment.

How to avoid:



Before replacing plug-in modules, touch a grounded object such as the control cabinet door. This discharges the human body.

6. Hang the replacement unit onto the fixing screws by using the lifting device. Tighten the screws.
7. Reconnect the unit as per the **interconnection diagrams of the machine manufacturer**.
8. If vertical axes have been secured prior to the replacement procedure, then remove the device with which these were secured.

The replacement is completed. The machine can be restarted.

6.2. Diagnostic display

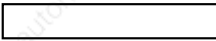
Note that the signals are only valid if the "+24V, +/-15V"-message is displaying a **stead green light!**

LEDs		OFF	Flashing	"Steady" light
				
H1B green	+24V / ±15V	Signal voltages faulty	_____	Signal voltages in order
H2B green	Bb1	Fault in supply module or in drive (1)	_____	Supply module and drives are fault-free
H3B green	MAINS	Connected load faulty, phase missing or mains voltage too low	_____	connected load in order
H4B green	POWER	mains contactor not on or faulty, power rectifier faulty	_____	DC bus voltage in order
H1A red	I-FAULT	current in power section within permissible limits	power on with short circuit in TVD, in the drive, in the cable or motor	shutdown due to overcurrent, short-circuit in TVD, in drive, in cable or in motor (1)
H2A red	P-FAULT	braking power of drive within permissible range	braking output of drive may not be permitted to rise further	shutdown due to excessive braking power (1)
H3A red	T-FAULT	unit temperature within permissible range	unit temperature too high, power shutdown in 30 seconds	power shutdown due to excessively high unit temperature (1)
H4A rot	U-FAULT	voltage in power section has not exceeded its maximum value	_____	overvoltage fuse has been tripped

TVD/Diagnoseanz

(1) Signal and unit locking is stored.
This can be cleared by pressing the reset key or by switching the electronics power source back on.

Fig. 6.1: Diagnostics displays of the TVD 1.3

6.3. Definition of the displays

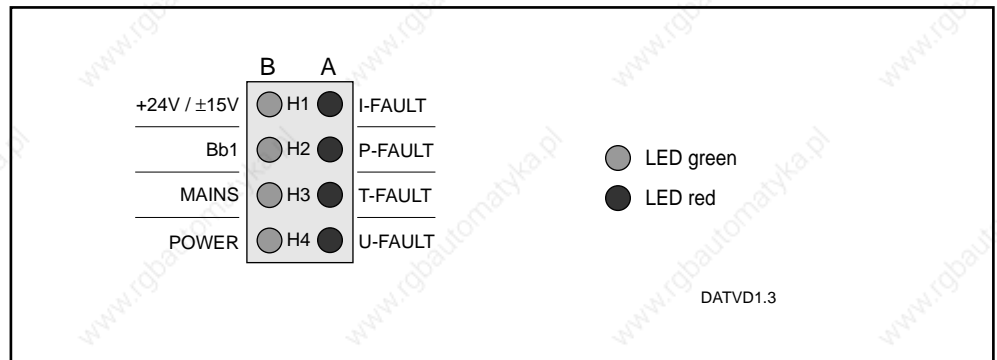
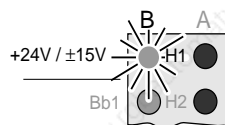

Fig. 6.2: Diagnostics displays on the TVD 1.3



+24 V/±15 V

Display green:

Signal voltages are OK.

(Operating status)

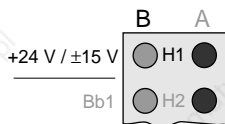

+24 V / ±15 V / +5 V

Display dark:

Signal voltage faulty.

(Fault - not stored)

Cause 1: Missing or faulty mains input voltage for electronic supply.

Remedy

Check mains fuse in the control panel.

Cause 2: Maximum load of the signal voltages exceeded.

Remedy

- 1. Disconnect wire-ribbon connection (X1) to the drive modules and check voltages at X3.**
- 2. Disconnect signal voltages and check for short-circuits (+ 24 V: max. 2 A; ± 15 V: respect. max. 100 mA).**

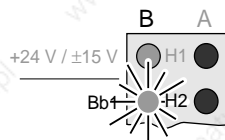

Bb1

Display green:

No faults in supply modules or drives.

(Operating status)

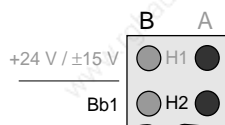

Bb1

Display dark:

Fault in supply module or drive.

(Fault - stored)

Cause 1: Fault in supply module

Remedy

Check the remaining diagnostics displays of the supply module.

Cause 2: Drive module fault

Remedy

Check diagnostics display of the drive module.

Cause 3: Fault in the signal voltage bus connection

Remedy

Check bus cable at X1 and end connector of the bus connection should be checked whether properly in place.

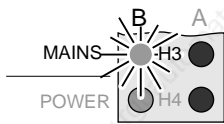
**MAINS**

Display green:
Power supply OK.

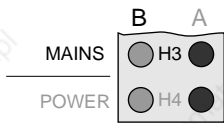
(Operating status)**MAINS**

Display dark:
Power supply faulty.

(Fault - not stored)

Cause : Main fuse acutated, mains phase at X7 missing or mains voltage too low.

Remedy

Check main connection (rated value: 3 x 380...480 V_{AC} ± 10 %)

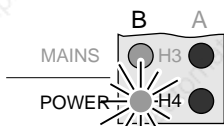
**POWER**

Display green:
Internal mains contctor ON; DC bus voltage OK.

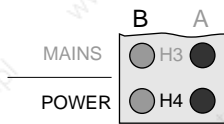
(Operating status)**POWER**

Display dark:
Mains contactor not on; fault in DC bus.

(Fault - not stored)

Cause 1: Mains contactor not on

Remedy

Check circuit at X2/6 (+ 24 V_L against 0 V_L).

Cause 2: DC bus smoothing choke missing or improperly connected

Remedy

Check connection of smoothing bus choke (between X7/1L+ and X7/2L+).

Cause 3: Faulty rectifier

Remedy

Replace unit.

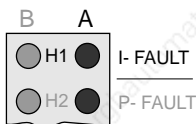
**I-FAULT****Display dark:****(Operating status)**

Current in power section within permissible range.

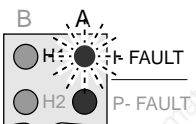
**I-FAULT****Display flashing:****(Fault - not stored)**

Power up OK even though there is a short circuit in the unit, drive module, cable or motor.

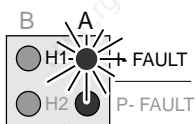
**I-FAULT****Display red:****(Fault - stored)**

Shutdown was triggered due to overcurrent in power section.

Cause 1: Defective drive module or damaged motor power cable. Short circuit in the motor. DC bus smoothing choke is disconnected.

Remedy

Remove conductor rails to the drive module; check drive module, motor power cable, motor and DC bus smoothing choke and replace, if necessary.

Remedy

Cause 2: Short-circuit in unit

Replace unit.

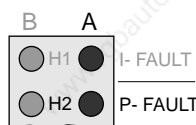
**P-FAULT****Display dark:****(Operating status)**

Braking power of drive within permissible range.

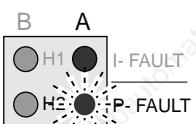
**P-FAULT****Display flashing:****(Warning)**

Bleeder is fully loaded. Braking power of drive may not continue to rise.

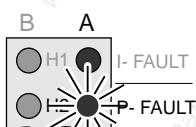
**P-FAULT****Display red:****(Fault - stored)**

Shutdown was triggered because bleeder is overloaded.

Cause 1: The braking power of the drive is too high

Remedy

1. Check energy content of the drives. Reduce drive speed or increase load cycle time.

2. Evaluate bleeder pre-warning contact (BVW contact).

Remedy

Cause 2: Bleeder defective or internal fault in unit

Replace unit.

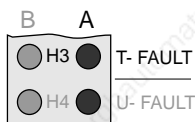

T-FAULT

Display dark:
Heatsink temperature within permissible range.

(Operating status)

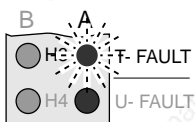

T-FAULT

Display flashing:
Heatsink temperature too high. Power will be switched off within the next 30 seconds.

(Warning)

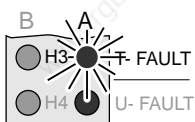

T-FAULT

Display red:
Shutdown was triggered as heatsink temperature too high.

(Fault - stored)

Cause: Unit overloaded or ambient temperature too high

Remedy

Check load or ambient temperature. Temperature pre-warning contact (TVW-Kontakt) of the unit must be evaluated.

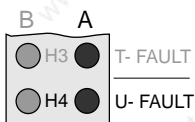

U-FAULT

Display dark:
DC bus voltage has exceeded permissible range.

(Operating status)

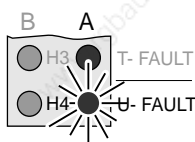

U-FAULT

Display red:
Shutdown was triggered because the DC bus voltage has exceeded maximum value.

(Fault - stored)

Cause 1: Mains voltage too high

Remedy

Check mains voltage (rated value: 3 x 380...480 V_{AC} ± 10 %); replace unit.

Cause 2: Fault in unit

Remedy

Replace unit.

6.4. Rating plate data

When contacting INDRAMAT Customer Service, please have all the information on this plate handy.

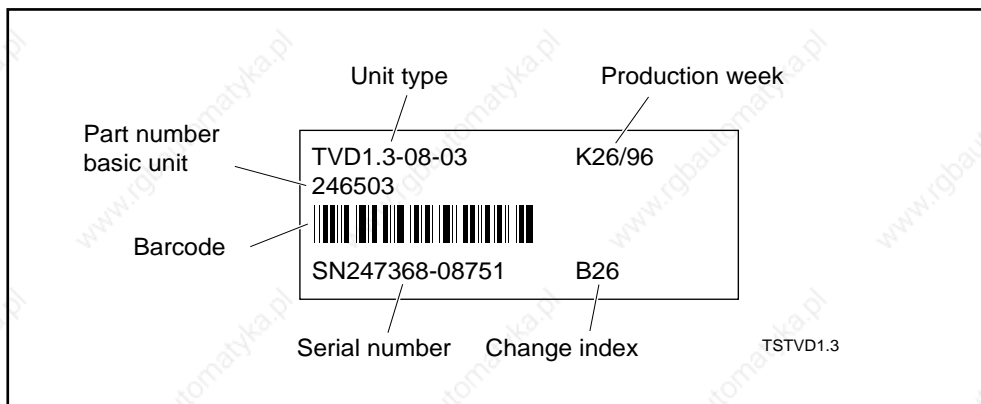

Fig. 6.3: Rating plate of the TVD 1.3

7. Dimensional data

7.1. Dimension sheet TDV 1.3 power supply module

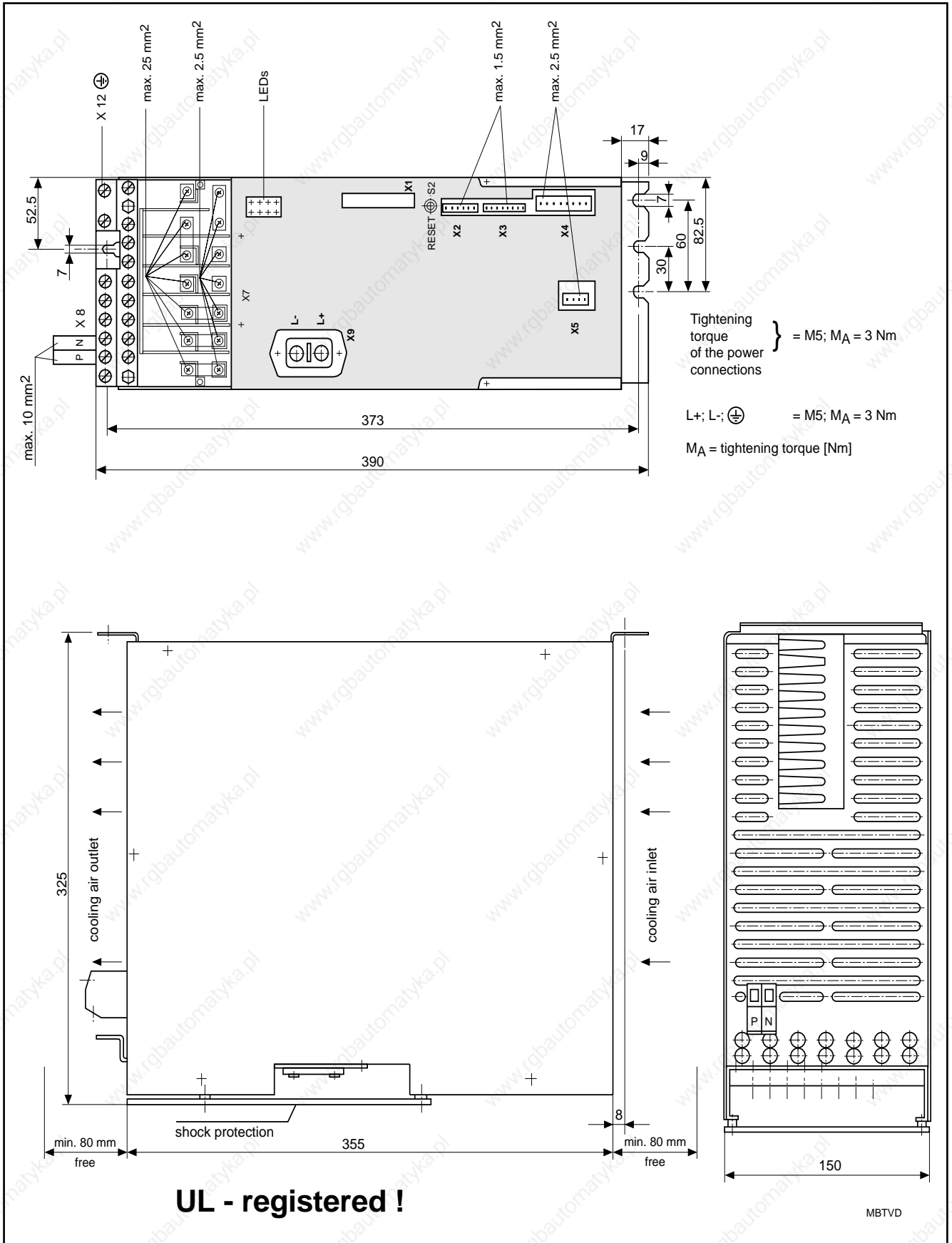

Fig. 7.1: Dimension sheet TVD 1.3 power supply module

7.2. Dimension sheet NAM 1.3 power adapting module

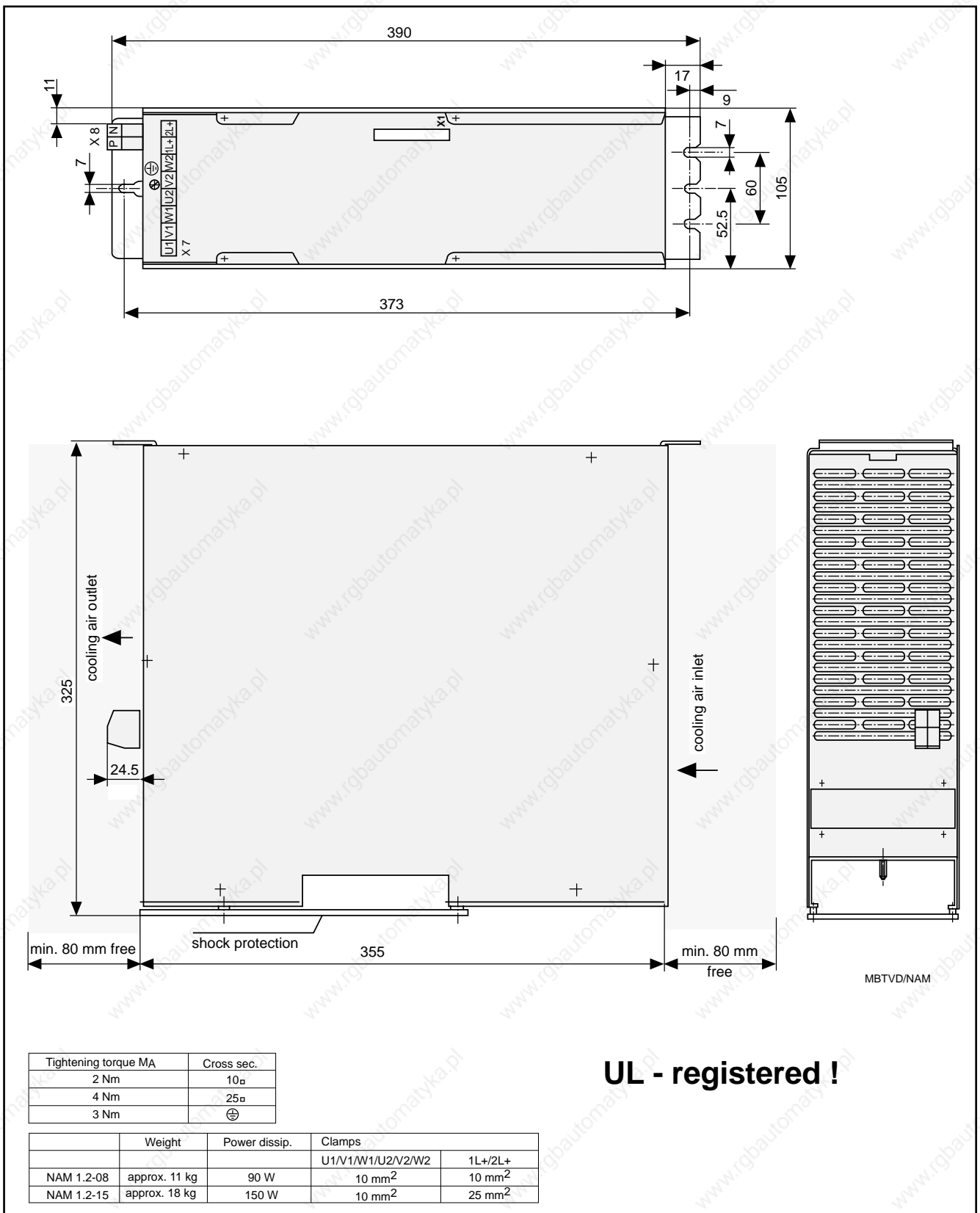

Fig. 7.2: Dimension sheet of NAM 1.3

7.3. Dimension sheet CZ 1.2-01-7 bus voltage capacitor

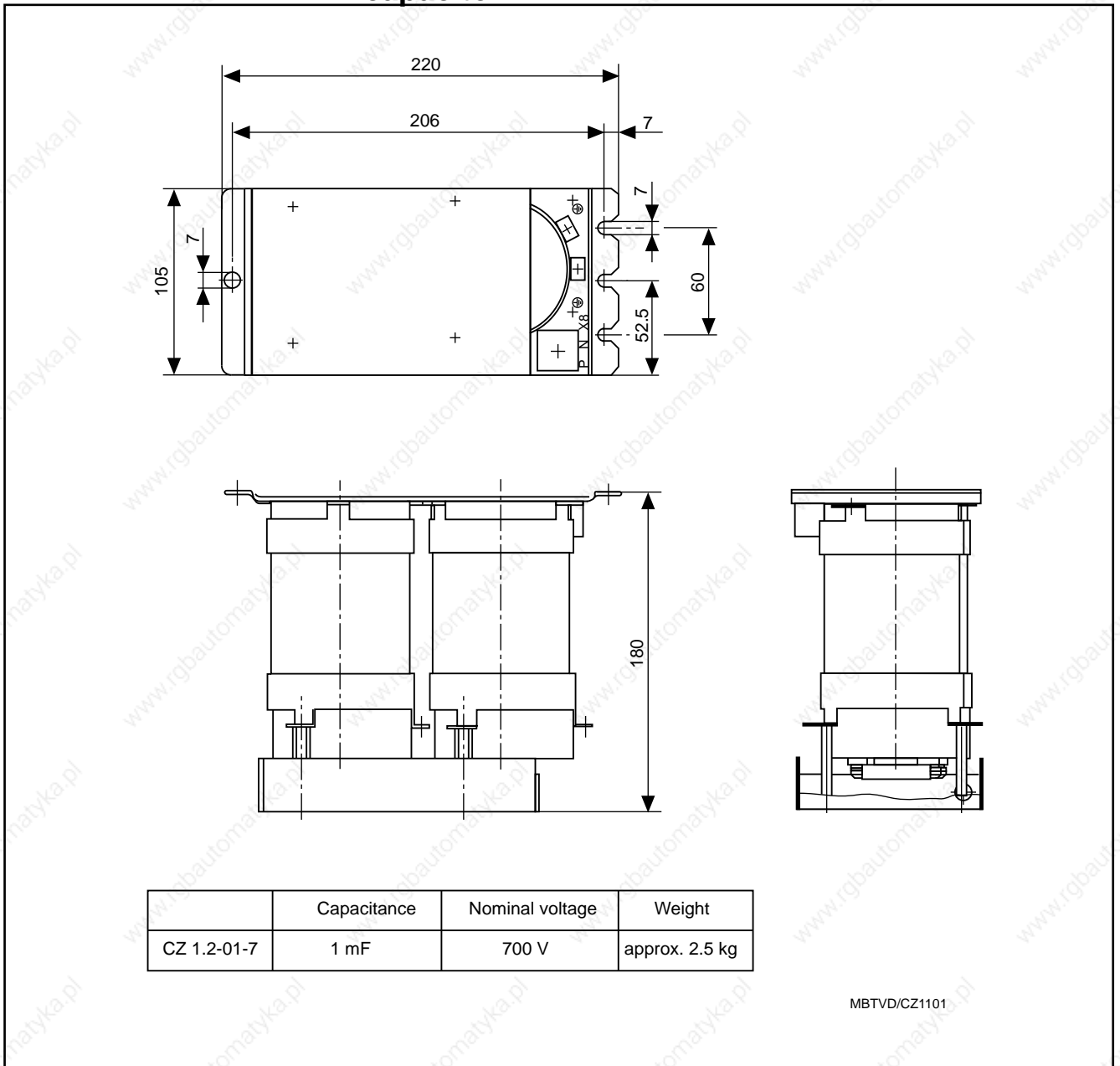

Fig. 7.3: Dimension sheet of the CZ 1.2-01-7

7.4. Dimension sheet KD 23/26 commutating chokes

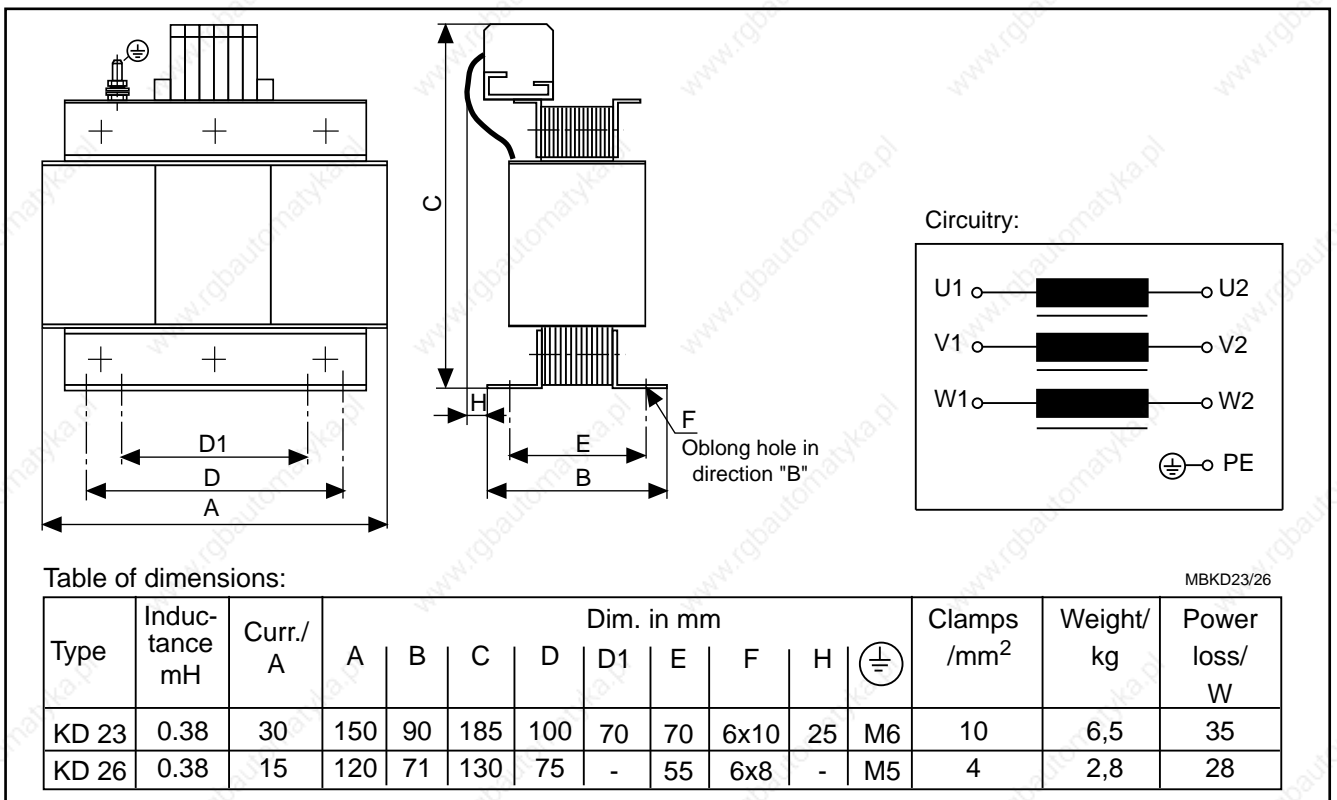

Fig. 7.4: Dimension sheet of the KD 23/26

7.5. Dimension sheet DC bus smoothing choke GLD 16/17

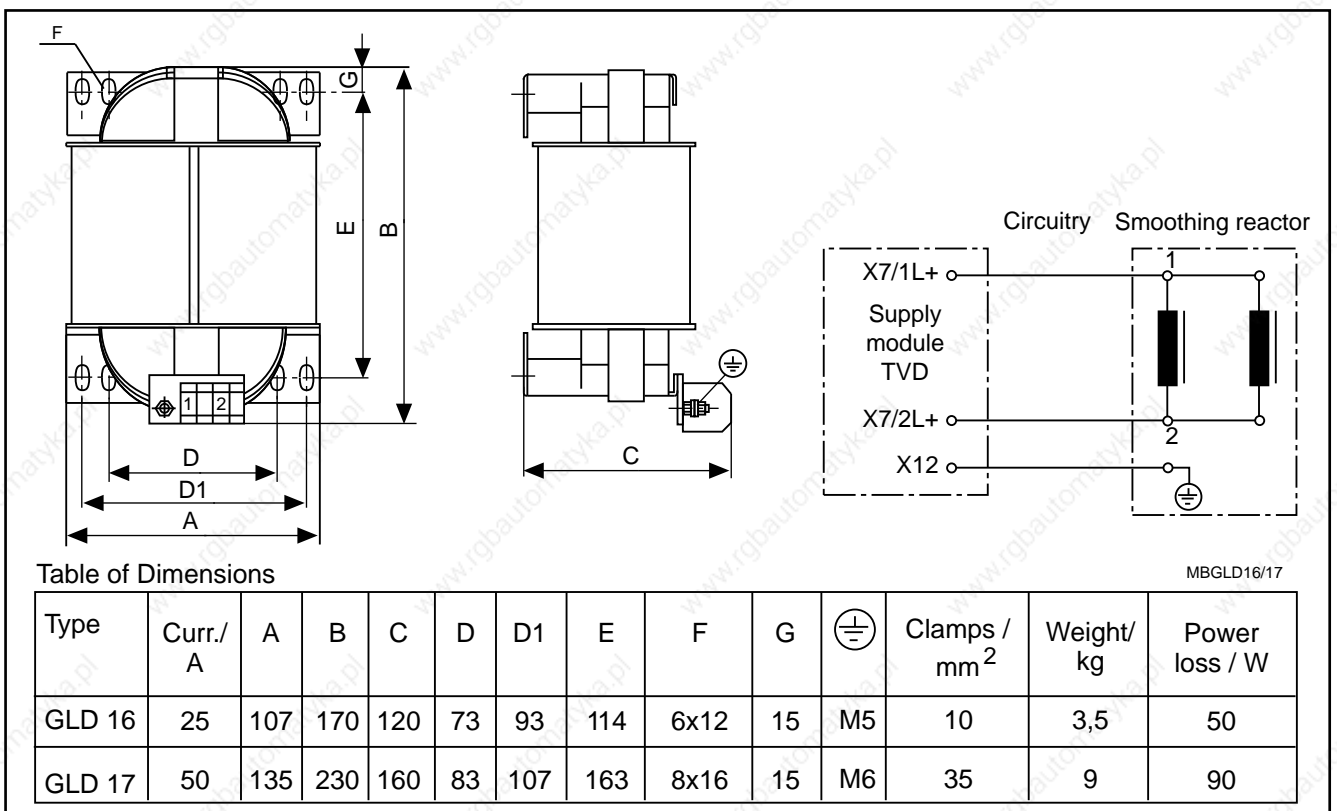

Fig. 7.5: Dimension sheet DC bus smoothing choke GLD 16/17

7.6. Dimension sheet CZ 1.02 auxiliary capacitance

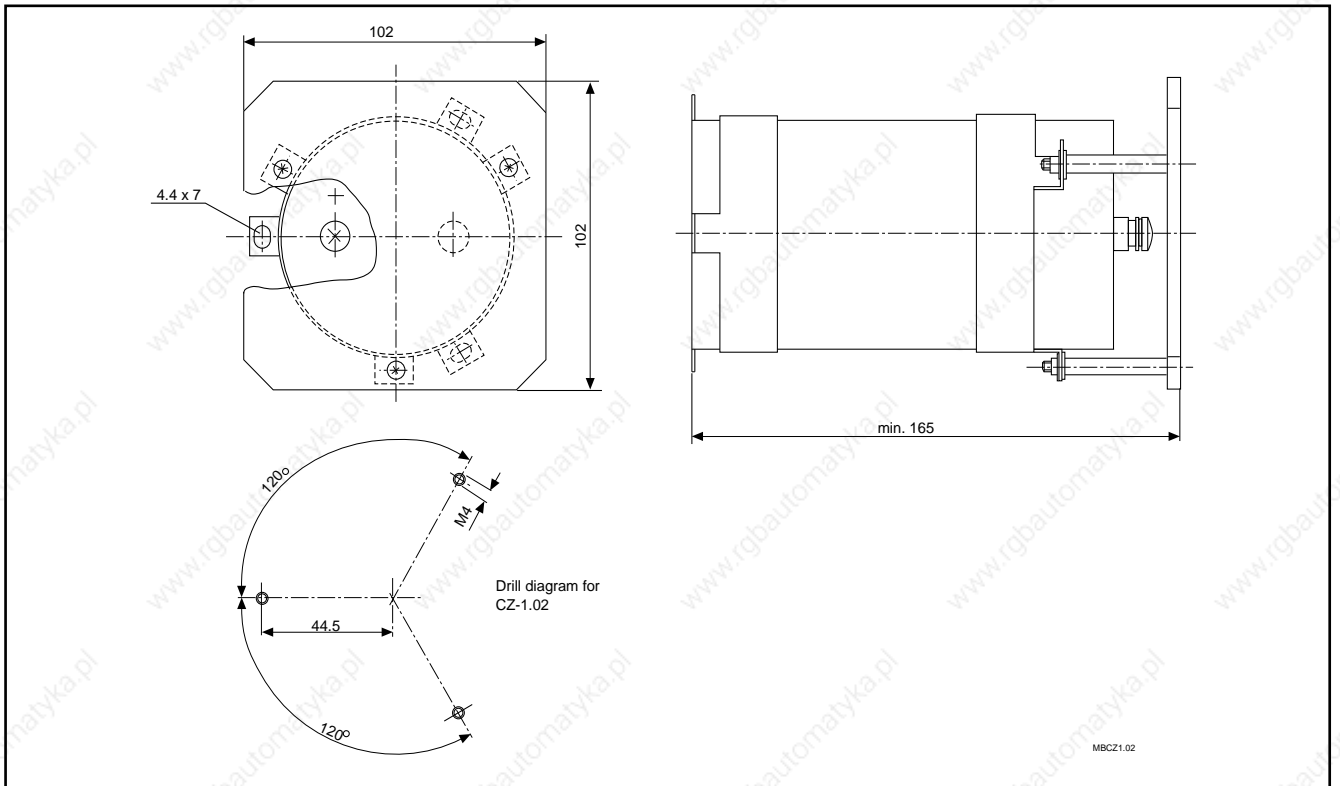

Fig. 7.6: Dimension sheet of the CZ 1.02

7.7. Dimension sheet TCM 1.1 aux. capacitance mod.

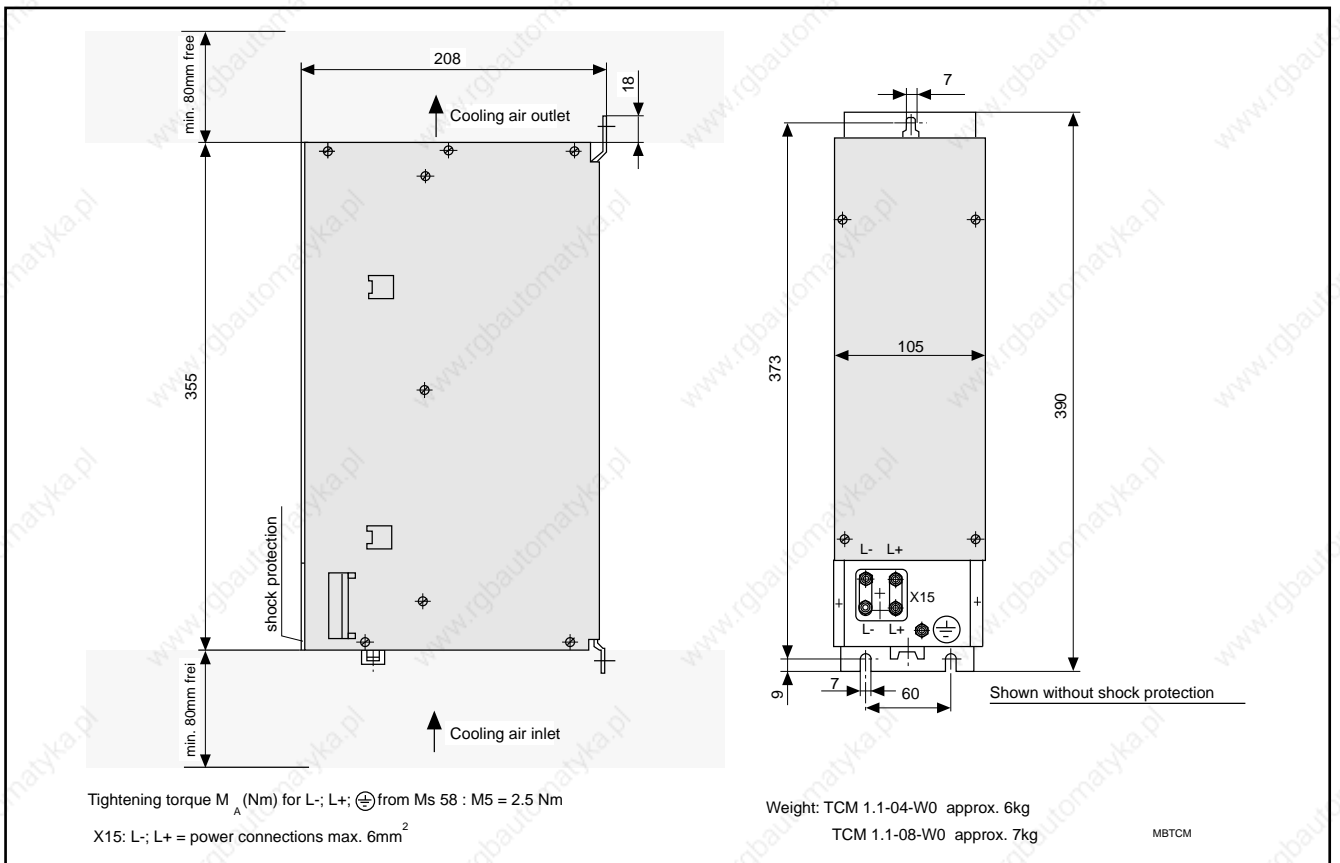

Fig. 7.7: Dimension sheet of the TCM 1.1

7.8. Dimension sheet TBM aux. bleeder module

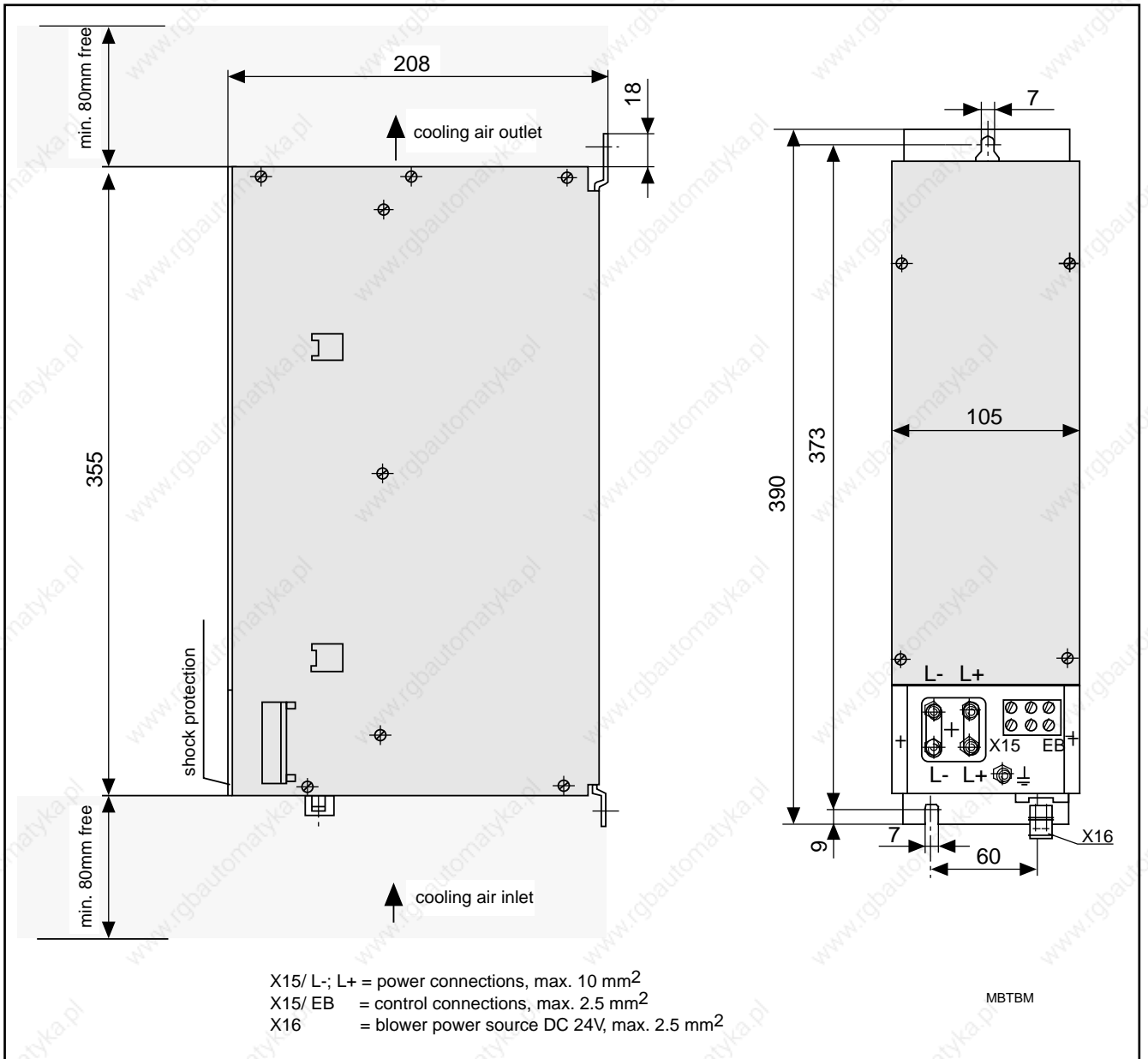

Fig. 7.8: Dimension sheet of the TBM

7.9. DST Autotransformers with a secondary or output voltage of 380...460 V

As a result of the broad input voltage range, the TVD 1.3 can be attached to most internationally used power systems without the use of a transformer. With mains rated voltages of < 380 V or > 480 V a transformer is required. The following transformers can be used in conjunction with the TVD 1.3 for rated mains voltage as listed in column 2 of the table. A special transformer type or transformer connection for each mains voltage is not required.

The connected load for the TVD 1.3 is dependent upon the voltage. When calculating the connected load take the output voltage of the mains transformer into account.

Example: mains voltage or transformer input voltage = $U_1 = 525 \text{ V}$, ratio = $\ddot{u} = 1.26$

$$U_2 = \frac{U_1}{\ddot{u}} = \frac{525 \text{ V}}{1.26} = 417 \text{ V}$$

$$S_{AN} = \frac{P_{DC} \cdot \sqrt{(3 \times 417 \text{ V})}}{25.5}$$

P_{DC} = DC bus cont. power in W S_{AN} = connected load in VA

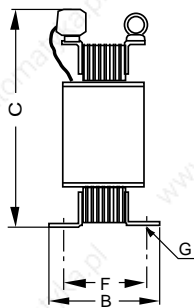
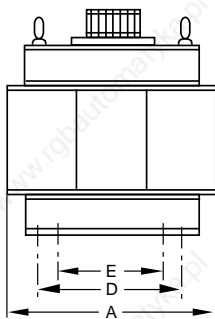

Type plate: example

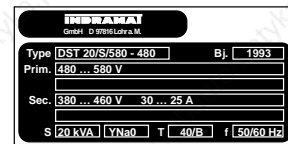

Circuits:

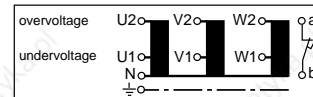

*) max. Belastung: DC 24V/1A; AC 230V/1A

Dimensional table:

Type DST	Primary or input voltage (±10%)	Dim. in mm							Weight kg	Clamps mm ²	Power dissip. W	Transmission ratio
		1) A	2) B	3) C	D	E	F	G Ø				
4/S/240-460	200...240V	240	150	260	170	110	120	11	24.5	10	120	$\ddot{u} = 0.52$
7.5/S/240-460		335	175	365	230	160	145	11	55	10	225	
12.5/S/240-460		360	190	395	250	170	160	11	70	10	310	
25/S/240-460		480	195	500	356	-----	158	13	135	35	500	
50/S/240-460		580	265	540	400	270	215	18	195	70	750	
4/S/580-460	480...580V	240	130	260	170	110	100	11	18	4	140	$\ddot{u} = 1.26$
7.5/S/580-460		240	140	260	170	110	110	11	22	4	260	
12.5/S/580-460		300	155	325	210	140	125	11	37	10	375	
25/S/580-460		360	190	395	250	170	160	11	72	10	625	
50/S/580-460		420	215	450	280	190	155	14	95	35	1000	
4/S/500-460	480...500V	180	105	190	125	80	75	7	8.5	4	160	$\ddot{u} = 1.09$
7.5/S/500-460		205	130	210	145	95	95	7	13	4	260	
12.5/S/500-460		240	140	260	170	110	110	11	22	10	440	
25/S/500-460		300	155	325	210	140	125	11	36	16	750	
50/S/500-460		335	175	365	230	160	145	11	53	35	1050	
4/S/690-460	570...690V	240	140	260	170	110	110	11	22	10	140	$\ddot{u} = 1.5$
7.5/S/690-460		300	155	325	210	140	125	11	37	10	225	
12.5/S/690-460		335	175	365	230	160	145	11	57	10	375	
25/S/690-460		420	205	450	280	190	145	14	88	16	500	
50/S/690-460		480	222	500	356	-----	185	13	178	35	750	

MBDStsteh

- 1) Nominal power n kVA 2) max. nominal input voltage in V 3) max. nominal output voltage in V

Fig. 7.9: DST autotransformers

8. Order information

8.1. Type codes TVD

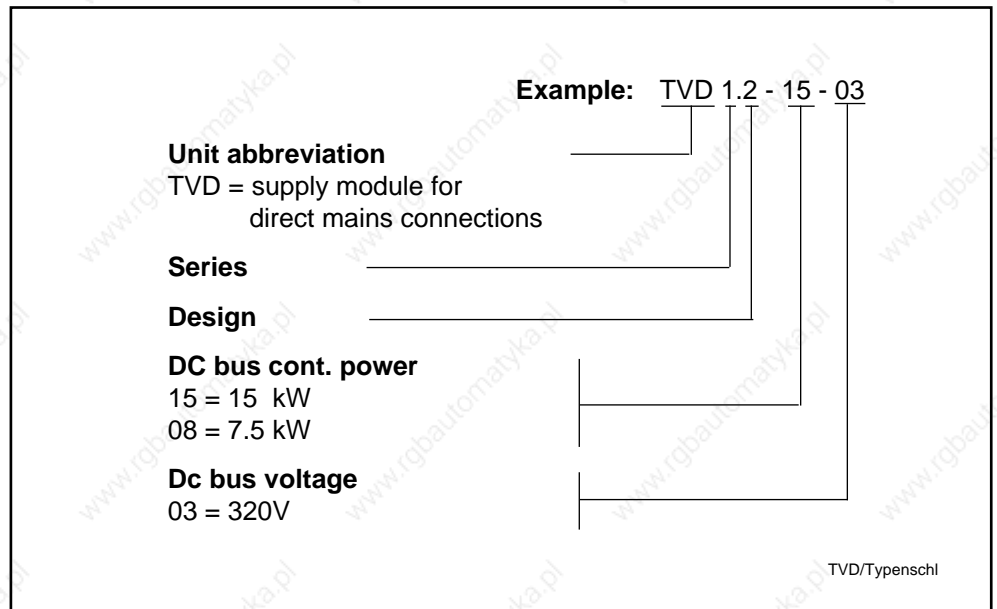

Fig. 8.1: Type codes TVD

8.2. Available supply module types of the TVD 1.3 and accessories

Designation	Available types
1. Supply module	TVD 1.3-08-3 TVD 1.3-15-3
1.1. electrical conn. accessories	E1-TVD E2-TVD E3-TVD
1.2. connector for blower supply of the drive modules	socket part no.: 219 118
2. Auxiliary devices	
2.1. Mains supply module	NAM 1.3-08 NAM 1.3-015 for bus conn. see section 8.4.
2.2. Capacitance	CZ 1.2-01-7
2.3. Commutating choke	KD 26 part no. 246 544 KD 23 part no. 246 429
2.4. DC bus smoothing choke	GLD 16 part no. 242 665 GLD 17 part no. 242 124
3. Aux. bleeder module	TBM 1.2-040-W1/024

8.3. Overview of electrical connecting accessories

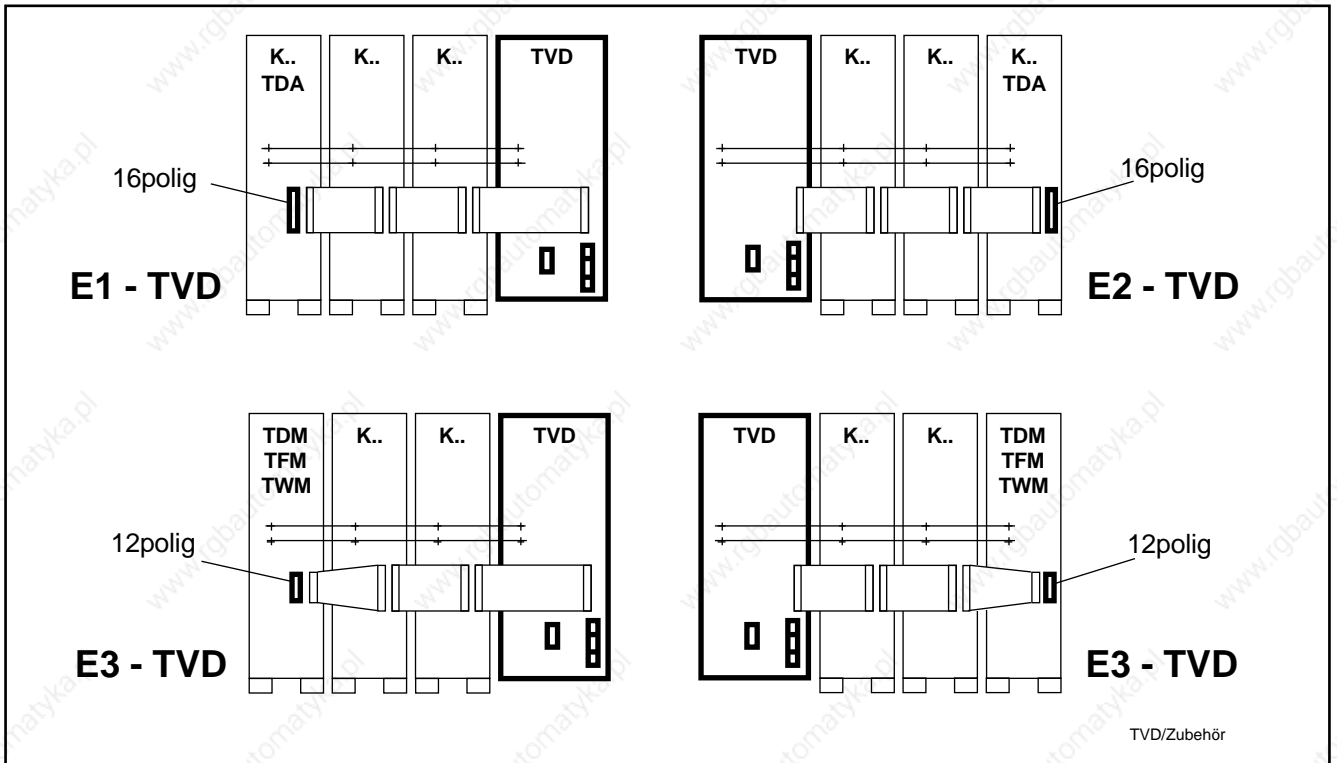

Fig. 8.2: Overview of electrical connecting accessories

8.4. Overview of 16-pin bus cable for NAM 1.3

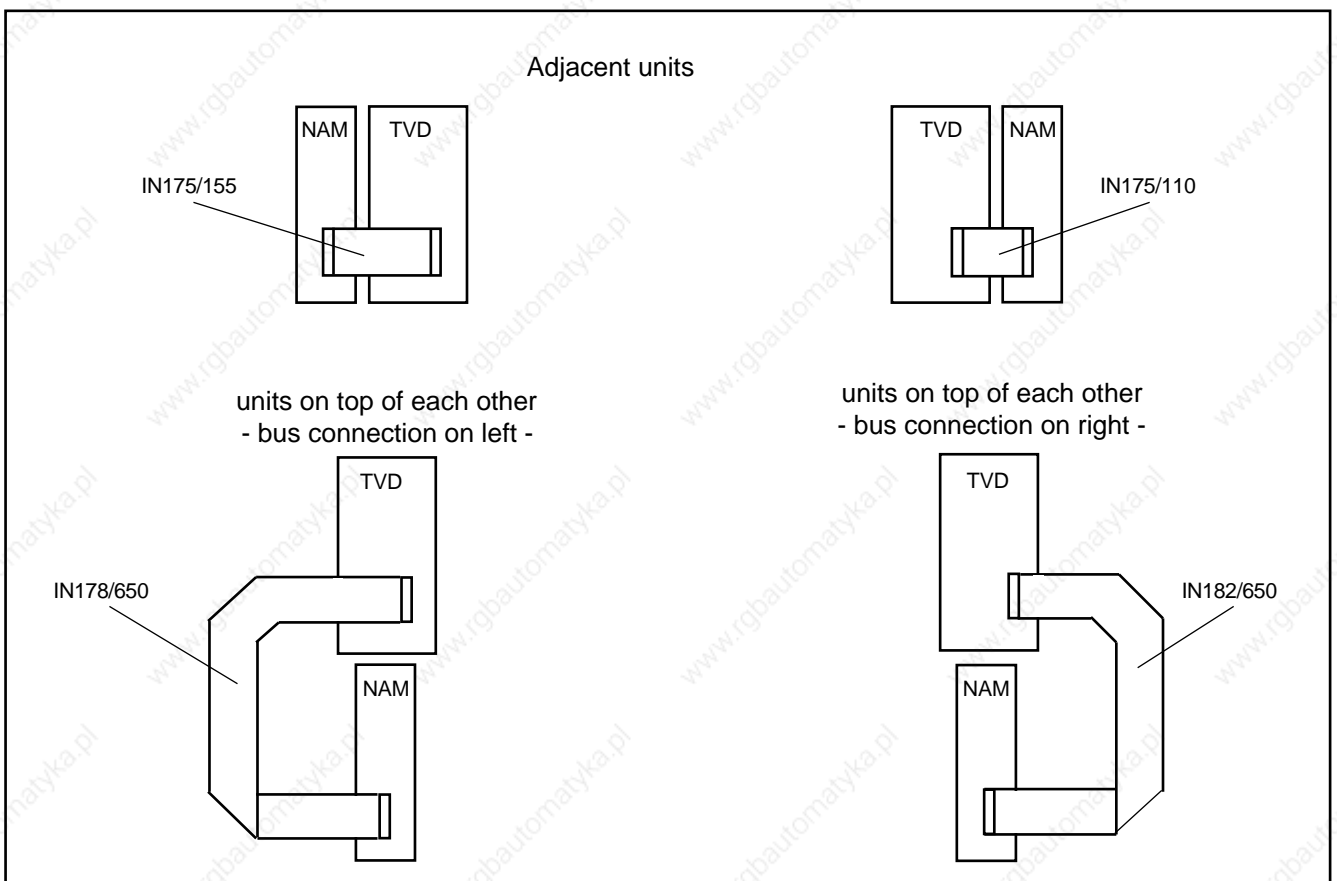

Fig. 8.3: Bus cable overview

8.5. Item list of mains supply with TVD 1.3

See section 8.2. for available types.

Item	Article
1.0	Supply module TVD 1.3-...-03
1.1	Electrical conn. accessories E.-TVD
2.0	Auxiliary devices optionally: mains adapter module NAM 1.3-.. bus conn. cable IN.../... or commutation choke KD.. and capacitance CZ 1.2-01-7 and DC bus smoothing choke GLD..
3.0	Aux. bleeder module TBM 1.2-040-W1/024

9. Index

A

Additional bleeder module TBM 25
Additional DC bus capacitanc 24
Ambient Conditions 13
Angular positioning error 42
Arranging the drives 31
Aux. bleeder module 67
Auxiliary contact 38

B

B6 circuit 30
Basic losses 33
Bb1 46
Bb1 contact 8, 38
Bleeder losses 33
Bleeder resistor 26
Blower 27
Bridge capacitance 24
Busbars 23

C

Capacitive leakage currents 30
Charging current limit 10
Choke 10
Commercial pulse-sensitive FI type current limitin 30
Commutation choke 17, 23
Compact mains adapter 17
Connected load 10
Connecting block X7 19
Control cabinet 31
Control voltage output 12
Current limiting protective devices 30
CZ 1.02 62

D

DC bus capacitors 10
DC bus circuit 8, 23, 42
DC bus dynamic braking 36
DC bus smoothing choke 17, 24
Diagnostic display 53
DIN 40 050 31
Direct mains connection 19
Drive system monitoring 8
DST Autotransformers 64

E

E-stop 40, 42
E-stop button 38
E-stop chain 42
Earthed three-phase mains 21
Electrical conn. accessories E.-TVD 67
Electrical connecting accessories 66

Electrical Connections 14
Electronics 27
Electronics Power 12
Electronics supply buffer capacitance 28
End plug 29
EPU+ 28
EPU+ and EPU- 28
EPU- 28
Extensive monitoring functions 8
External bleeder resistor 26
External jumper 10
Extreme load capabilities 10

F

False tripping 30
Fault signal 38
FI type current limiting circuit breakers 30
Front view 34
Functional power features 10
Fuse protection 21
Fuse rating 21

G

Gearboxes 42
Generator mode 8
Grounded wye or delta system 21

H

High-voltage link 8

I

Increased ambient temperatures 13
Individual components connected in series 16
Inductance machine 42
Input OFF 44
Input ON 44
Input ZKS 44
Installation elevations 13
Installation requirements 31
Interconnect diagram 15
Internal DC bus dynamic braking 10
IP 10, 31
Isolation transformer 21
Isolation transformers 30
IT mains 21
Item list 67

K

KD 23/26 61

L

"L+ line" 24
Leakage current 20, 30
Leakage inductance 20

M

- Main functions 8
- Mains connection to power circuits 19
- Mains connection via a transformer 20
- Mains failure 28
- Mains filter 30
- Mains frequency 19
- Mains inductance 20
- Mains perturbation 17
- Mains supply earthing requirements 21
- Mains voltage 19
- Maximum acceleration rating 11
- Maximum fusing 21
- Maximum length 23
- Maximum number of drives 31
- Miniature circuit-breaker 27
- Monitor circuits 42
- Monitoring functions 8

N

- NAM 1.3 17, 59, 66, 67
- NCB Link 45
- NCB link 36, 38, 40, 42
- Non-periodic overvoltages 22

O

- Order information 65
- Output Bb1 46
- Output BVW 48
- Output K1NC 49
- Output K1NO 49
- Output TVW 49
- Output UD 48
- Overload capabilities 10, 11
- Overtravel signal 38
- Overview of 16-pin 66
- Overvoltages 22

P

- Periodic overvoltage 22
- Permanent magnetic fields 10
- Position-control 42
- Potential-free contact 10
- Power losses 33
- Power OK 48
- Power range 9
- Power ratings 11
- Power section 12
- Power shutdowns 10
- Power stages 10
- Power supply to the drives 8

R

- "Ready" status 46
- Regulated current consumption 17
- Regulated DC bus voltage 10

Return movements 42
rf interference suppression filters 30

S

Safety clearance 33
Semi-conductor devices 21
Series connected units 17
Service life 10
Servo fault 38
Shielded conductors 30
Signal Voltages 46
Signal voltages 8
Spacing dimensions 32
Storage capacitance 28
Storage capacitor 17
Supply system requirements 19
Supply to electronics and fan 27
Supply to the electronics 8
Switched-mode drive controllers 30
Switching rate 44
System perturbations 24

T

TBM 63
TBM 1.2 25
TBM 1.2-040-W1/024 67
TCM 1.1 62
Terminating plug 29
TVD 1.3 Interconnections 35
TVD 1.3 supply module 7
TVD 1.3 with adapter module NAM 1.3 17
TVD 1.3 with separate series components 18
TVD's diagnostic signals 27
Type codes 65

U

UD contact 42
UD output 28
UL Registered 10
Unearthed three-phase mains 21
Utilization category gL 21

V

Voltage across the resistor 26
Voltage dips 19
Voltage interrupt 19

W

Wire ribbon cable 8
Wire ribbon connection 29
Wiring diagram 14
Wye point 30

X

X1 29

