

Danaher Motion Pacific Scientific

CE Marked Single Axis
Resolver- Based Brushless Servo Drives

**SCE900 Family Hardware
Reference Manual**

Document Number: MAE900
Rev 005
List Price: \$65 US

Record of Manual Revisions

ISSUE NO.	DATE	BRIEF DESCRIPTION OF REVISION
5	10/31/02	Updated contact information

Copyright Information

© Copyright 1997 - 2002 Danaher Motion Pacific Scientific - All rights reserved.
Printed in the United States of America.

NOTICE:

Not for use or disclosure outside of Danaher Motion Pacific Scientific Company except under written agreement. All rights are reserved. No part of this book shall be reproduced, stored in retrieval form, or transmitted by any means, electronic, mechanical, photocopying, recording, or otherwise without the written permission from the publisher. While every precaution has been taken in the preparation of the book, the publisher assumes no responsibility for errors or omissions. Neither is any liability assumed for damages resulting from the use of the information contained herein.

This document is proprietary information of Danaher Motion Pacific Scientific Company that is furnished for customer use ONLY. No other uses are authorized without written permission of Pacific Scientific Company. Information in this document is subject to change without notice and does not represent a commitment on the part the Pacific Scientific Company. Therefore, information contained in this manual may be updated from time-to-time due to product improvements, etc., and may not conform in every respect to former issues.

Limited Warranty

Includes software provided by Pacific Scientific

Seller warrants that the Goods sold hereunder are free from defects in material and workmanship for the product warranty period of each item of Goods (Product Warranty Periods are listed below). Seller warrants its Good(s) only to the original purchaser (the "Customer"), and in the case of original equipment manufacturers or distributors, only to their original consumer (the "Customer"). There are no warranties whatsoever on Goods built or acquired, wholly or partially, to a buyer's designs or specifications

This express warranty is in lieu of and exclude all other warranties, express or implied, by operation or law or otherwise including THE WARRANTY OF MERCHANTABILITY AND FITNESS FOR A PARTICULAR PURPOSE (WHETHER KNOWN TO SELLER OR NOT), all other such warranties being hereby expressly disclaimed by Seller and waived by Buyer.

Written notice of claimed defects shall have been given to Seller within the period set forth in the schedule below, and within thirty (30) days from the date any such defect is first discovered.

Product Warranty Schedules

<u>Brand</u>	<u>Products</u>	<u>Warranty Period</u>
Pacific Scientific	All Products	24 months from date of manufacture
Superior	All Products	12 months from date of manufacture
Kollmorgen	Standard Brush-type Motors, Electronics and Accessories	12 months from date of manufacture
Kollmorgen	Standard Brushless Motors, Electronics and Accessories	24 months from date of manufacture
Kollmorgen	Standard Step Motors, Stepper Controls and Accessories	12 months from date of manufacture
Kollmorgen	Custom Motion Systems or components of any type	To be negotiated on a case-by-case basis, and set forth in the order.

The Good or parts claimed to be defective must be returned to Seller, accompanied by a Return Material Authorization (RMA) issued by Seller's facility responsible for supplying Goods, with transportation prepaid by Customer, with written specifications of the claimed defect.

If a warranty claim is valid, Seller shall pay reasonable one-way costs of transportation of the defective Goods from either the original destination or the location where defect occurred, whichever is closest to Seller's facility. Under no circumstances shall Seller be liable for removal of Seller's Goods from Buyer's equipment or re-installation into Buyer's equipment.

NO PERSON, INCLUDING ANY AGENT, DISTRIBUTOR, OR REPRESENTATIVE OF SELLER, IS AUTHORIZED TO MAKE ANY REPRESENTATION OR WARRANTY ON BEHALF OF SELLER CONCERNING ANY GOODS MANUFACTURED BY SELLER, EXCEPT TO REFER PURCHASERS TO THIS WARRANTY.

SAFETY

The equipment described herein has been developed, produced, tested and documented in accordance with the corresponding standards. During use conforming with requirements, the equipment is not dangerous for people or equipment. Use conforming with requirements means that the safety recommendations and warnings detailed in this manual are complied with and applicable regulations for safety (machine directives, etc.) and noise suppression (EMC Directives) are observed while operating the drive. At the end of its lifetime, dispose of or recycle the drive according to the applicable regulations.

Installation and wiring of the drive must be completed only by qualified personnel having a basic knowledge of electronics, installation of electronic and mechanical components, and all applicable wiring regulations.

Commissioning of the machine utilizing the drives must be done only by qualified personnel having a broad knowledge of electronics and motion control technology.

As the user or person applying this unit, you are responsible for determining the suitability of this product for the application. In no event is Danaher Motion Pacific Scientific responsible or liable for indirect or consequential damage resulting from the misuse of this product.

Read this manual completely to effectively and safely operate the SCE900 family.

Comply with the applicable European standards and Directives.

Contents

1. INTRODUCTION	1-1
1.1. FEATURES.....	1-1
1.2. STANDARD FEATURES.....	1-2
1.3. OPTION CARDS.....	1-2
2. MODEL IDENTIFICATION	2-1
2.1. BASIC ORDER NUMBERING SYSTEM.....	2-1
2.1.1. <i>Part Number Designation</i>	2-1
2.1.2. <i>Example Order Numbers</i>	2-2
2.2. ACCESSORIES	2-3
2.2.1. <i>Plug-in Cards</i>	2-3
2.2.2. <i>Connector Mate Kits</i>	2-3
2.2.3. <i>Forced Air Cooling</i>	2-3
2.2.4. <i>Manual and Documentation Kits</i>	2-4
3. SPECIFICATIONS	3-1
3.1. OUTPUT POWER.....	3-1
3.2. INPUT POWER.....	3-2
3.2.1. <i>SCE900 Control Power Supply</i>	3-2
3.2.1.1. <i>Ride Through Time For AC Line Drop</i>	3-2
3.2.1.2. <i>SCE900 Motor AC Power Supply</i>	3-2
3.2.1.3. <i>Bus Voltage (nominal, standard drive)</i>	3-3
3.3. PERFORMANCE CHARACTERISTICS	3-3
3.3.1. <i>Motor Current Control</i>	3-3
3.3.2. <i>Analog Command</i>	3-3
3.3.3. <i>Digital Position Commands</i>	3-4
3.3.4. <i>Velocity Loop</i>	3-4
3.3.5. <i>Position Loop</i>	3-4
3.3.6. <i>General</i>	3-5
3.3.7. <i>Environmental</i>	3-5
3.3.8. <i>Mechanical</i>	3-5
3.3.9. <i>Size</i>	3-5
3.3.10. <i>Weight</i>	3-5
3.4. RESOLVER FEEDBACK.....	3-6
3.4.1. <i>Resolver Position Signal</i>	3-6
3.4.2. <i>Resolver Velocity Signal</i>	3-6
3.4.3. <i>Emulated Encoder Output Signals</i>	3-7
3.4.4. <i>General</i>	3-7
3.5. USE CONFORMING WITH REQUIREMENTS	3-7

3.6.	CE APPROVAL.....	3-7
3.6.1.	<i>Declaration of Conformity</i>	3-8
3.6.2.	<i>Declaration of Conformity Certificate</i>	3-8
4.	INSTALLATION	4-1
4.1.	INSTALLATION AND COMMISSIONING.....	4-1
4.2.	SAFETY REQUIREMENTS	4-1
4.2.1.	<i>Your Responsibility</i>	4-1
4.2.2.	<i>European Directives</i>	4-1
4.3.	INSTALLING THE SCE900 DRIVE	4-2
4.3.1.	<i>Mounting the Drive</i>	4-2
4.3.2.	<i>9x3 CE Block Diagram</i>	4-3
4.3.3.	<i>9x4 CE Block Diagram</i>	4-4
4.3.4.	<i>9x5 CE Block Diagram</i>	4-5
4.3.4.1.	Mounting Guidelines	4-6
4.3.4.1.1.	SCE9x3 Outline Dimensions	4-6
4.3.4.1.2.	SCE9x4 Outline Dimensions	4-7
4.3.4.1.3.	SCE9x5 Outline Dimensions	4-8
4.3.4.2.	Connecting AC Power	4-9
4.3.4.2.1.	AC Power	4-9
4.3.4.2.2.	Fusing	4-9
4.3.4.2.3.	J1	4-9
4.3.4.2.4.	J6	4-9
4.3.5.	<i>Connection to PE Ground</i>	4-10
4.3.6.	<i>Grounding Shields for Safety & Low Emissions/Susceptibility</i>	4-10
4.3.7.	<i>Grounding the Motor Case</i>	4-11
4.3.8.	<i>Long Motor Power Cables</i>	4-11
4.4.	REQUIREMENTS FOR SAFE OPERATION OF THE DRIVE	4-11
4.4.1.	<i>Emergency Stop</i>	4-11
4.4.2.	<i>Avoiding Unexpected Motion</i>	4-11
4.4.3.	<i>Avoiding Electrical Shock</i>	4-12
4.4.4.	<i>Avoiding Burns</i>	4-12
4.5.	PREVENTING DAMAGE TO THE DRIVE	4-12
5.	I/O TERMINATIONS	5-1
5.1.	SCE900 POWER BOARD CONNECTORS	5-1
5.1.1.	<i>J1 AC Power</i>	5-1
5.1.2.	<i>J6 Control Power</i>	5-1
5.1.3.	<i>J5 Regeneration Interface</i>	5-2
5.2.	SCE900 BASE SERVO DRIVE USER I/O CONNECTIONS.....	5-2
5.2.1.	<i>J3 Feedback</i>	5-2
5.2.2.	<i>J4 Command I/O</i>	5-3

5.3.	DRIVE WRING DIAGRAM	5-4
5.4.	I/O DEFINITIONS	5-5
5.4.1.	<i>Chassis Ground Stud</i>	5-5
5.4.2.	<i>J1 AC Power</i>	5-5
5.4.2.1.	L1, L2, L3	5-5
5.4.2.2.	Chassis Ground	5-5
5.4.3.	<i>J6 Control Power</i>	5-5
5.4.3.1.	N, L1	5-5
5.4.3.2.	Chassis Ground	5-5
5.4.4.	<i>J2 Motor Power</i>	5-5
5.4.4.1.	Motor Phase U, V, W	5-5
5.4.4.2.	Motor Case Ground.....	5-5
5.4.5.	<i>J5 Regeneration Interface</i>	5-6
5.4.5.1.	PE, Internal Regen Resistor, Regen Resistor, -Bus, + Bus	5-6
5.4.5.2.	External regen resistor	5-6
5.4.6.	<i>J3 Resolver</i>	5-6
5.4.6.1.	Resolver S1, S2, S3, S4 Inputs.....	5-6
5.4.6.2.	Resolver R1 Excitation, R2 Excitation RTN Outputs	5-6
5.4.6.3.	Motor PTC, PTC RTN Inputs	5-7
5.4.7.	<i>J4 Command I/O</i>	5-7
5.4.7.1.	Analog CMD (+), (-) Inputs J4-1, 2.....	5-7
5.4.7.2.	DAC Monitor 1, 2 Outputs J4-3, 4	5-7
5.4.7.2.1.	DAC Monitor List Table.....	5-8
5.4.7.3.	J4 Analog and Digital I/O Interface Schematics.....	5-9
5.4.7.4.	I/O RTN J4-5, 13, 18	5-10
5.4.7.5.	Enable Input J4-6	5-10
5.4.7.6.	J4 Encoder I/O Interface Schematics Diagram.....	5-14
5.4.7.6.1.	Encoder Inputs.....	5-14
5.4.7.6.2.	Emulated Encoder Outputs.....	5-14
6.	DIAGNOSTICS AND PROTECTION CIRCUITS.....	6-1
6.1.	FAULT SEQUENCE.....	6-1
6.2.	FAULT CODES.....	6-2
6.3.	CUSTOMER SUPPORT/CONTACT INFORMATION.....	6-6
7.	POWER UP/DOWN SEQUENCING	7-1
7.1.	MA930	7-1
7.2.	INSTALLING 930WIN.EXE.....	7-1
7.3.	STARTING 930WIN.....	7-1
7.4.	CONFIGURING A DRIVE.....	7-2

8.	SCE902	8-1
8.1.	FEATURES	8-1
8.2.	STANDARD FEATURES	8-2
8.3.	OPTION CARDS	8-2
8.4.	SCE902 ACCESSORIES	8-3
8.4.1.	<i>Plug-in Cards</i>	8-3
8.4.2.	<i>Connector Mate Kits</i>	8-3
8.4.3.	<i>Manual and Documentation Kits</i>	8-3
8.5.	ELECTRICAL SPECIFICATIONS	8-4
8.5.1.	<i>Output Power</i>	8-4
8.5.2.	<i>Input Power</i>	8-5
8.6.	PERFORMANCE CHARACTERISTICS	8-6
8.6.1.	<i>Motor Current Control</i>	8-6
8.6.2.	<i>Analog Command</i>	8-6
8.6.3.	<i>Digital Position Commands</i>	8-7
8.6.4.	<i>Velocity Loop</i>	8-7
8.6.5.	<i>Position Loop</i>	8-8
8.6.6.	<i>General</i>	8-8
8.6.7.	<i>Environmental</i>	8-8
8.6.8.	<i>Mechanical</i>	8-8
8.6.9.	<i>Size</i>	8-8
8.6.10.	<i>Weight</i>	8-9
8.7.	RESOLVER FEEDBACK SPECIFICATIONS	8-9
8.7.1.	<i>Resolver Position Signal</i>	8-9
8.7.2.	<i>Resolver Velocity Signal</i>	8-9
8.7.3.	<i>Emulated Encoder Output Signals</i>	8-10
8.7.4.	<i>General</i>	8-10
8.8.	USE CONFORMING WITH REQUIREMENTS	8-10
8.9.	CE-APPROVAL	8-10
8.9.1.	<i>Declaration of Conformity</i>	8-11
8.10.	INSTALLATION	8-13
8.10.1.	<i>Installation and Commissioning</i>	8-13
8.10.1.1.	<i>Installation</i>	8-13
8.10.1.2.	<i>Commissioning</i>	8-13
8.10.2.	<i>Safety Requirements</i>	8-13
8.10.3.	<i>European Directives</i>	8-13
8.10.3.1.	<i>Safety</i>	8-13
8.11.	INSTALLING THE SCE900 SERVO DRIVE	8-15
8.11.1.	<i>Mounting the Drive</i>	8-15
8.11.2.	<i>9x2 CE Block Diagram</i>	8-16
8.11.3.	<i>Mounting Guidelines</i>	8-17
8.11.4.	<i>Grounding</i>	8-18

8.11.4.1.	Connection to PE Ground.....	8-18
8.11.4.2.	Grounding Shields for Safety & Low Emissions/Susceptibility.....	8-18
8.11.4.3.	Grounding the Motor Case	8-19
8.11.5.	<i>Requirements for Safe Operation of the Drive</i>	8-19
8.11.5.1.	Emergency Stop	8-19
8.11.5.2.	Avoiding Unexpected Motion	8-19
8.11.5.3.	Avoiding Electrical Shock	8-20
8.11.5.4.	Avoiding Burns.....	8-20
8.12.	PREVENTING DAMAGE TO THE DRIVE	8-20
8.13.	EMC.....	8-21
8.13.1.	<i>Line filter</i>	8-21
8.13.2.	<i>MTE Corporation</i>	8-21
8.13.3.	<i>Shielding & Grounding</i>	8-21
8.14.	I/O TERMINATIONS.....	8-22
8.14.1.	<i>Earth Ground</i>	8-22
8.14.2.	<i>SCE902 Power Board Connectors</i>	8-22
8.14.2.1.	J1	8-22
8.14.2.2.	J2	8-22
8.14.2.3.	J5	8-22
8.14.3.	<i>SCE902 Base Servo Drive User I/O Connections</i>	8-23
8.14.3.1.	J3	8-23
8.14.3.2.	J4	8-23
8.15.	DRIVE WIRING DIAGRAM	8-24
8.16.	I/O DEFINITIONS	8-25
8.16.1.	<i>Earth Ground</i>	8-25
8.16.2.	<i>J1 AC Power</i>	8-25
8.16.2.1.	Fusing	8-25
8.16.3.	<i>J2 Motor Power</i>	8-25
8.16.4.	<i>J5 Regeneration Interface</i>	8-26
8.16.4.1.	Internal Resistors	8-26
8.16.5.	<i>J3 Resolver</i>	8-26
8.16.6.	<i>J4 Command I/O</i>	8-27
8.16.6.1.	DAC Monitor List Table.....	8-28
8.16.6.2.	J4 Analog and Digital I/O Interface Schematics	8-29
8.16.6.3.	J4 Encoder I/O Interface Schematics Diagram	8-33
8.16.6.3.1.	Encoder Inputs	8-33
8.16.6.3.2.	Emulated Encoder Outputs	8-33
8.17.	OPERATING WITHOUT AN OPTION CARD	8-34
8.18.	DIAGNOSTICS AND PROTECTION CIRCUITS	8-34
8.18.1.	<i>Fault Sequence</i>	8-35
8.18.2.	<i>Fault Codes</i>	8-35
8.18.3.	<i>Status LED Code List</i>	8-36

8.18.4.	<i>Status LED Troubleshooting</i>	8-38
8.19.	POWER UP/DOWN SEQUENCING.....	8-40
8.20.	PC USER INTERFACE.....	8-41
8.20.1.	<i>MA930</i>	8-41
8.20.1.1.	Installing 930WIN.EXE	8-41
8.20.1.2.	Starting 930WIN.....	8-42
8.20.1.3.	Configuring a Drive.....	8-42
8.21.	CUSTOMER SUPPORT/CONTACT INFORMATION.....	8-42

1. INTRODUCTION

The SCE900 is a family of economical, high performance medium power single axis servo drives meant to go with resolver equipped brushless 3-phase permanent magnet motors. The SCE900 family shares the exact same control interface as the SC900 family, but the power electronics have been changed to be compatible with U.S. 480 VAC lines and European 400 VAC 3-phase mains and to comply with CE norms.

1.1. Features

All digital DSP-based control including the current loops.

All system and application parameters set in software

Digital auto-tuning for easy and predictable set-up

Advanced patented Digital Resolver to Digital (DRDC) converter with standard 5.3 arc minute absolute accuracy and 24 bit position resolution. U.S. patent number 5,162,798.

Advanced Signature Series sinusoidal current control for low shaft torque ripple and uniform control dynamics at all shaft speeds.

Modular construction with a user removable option card allowing easy configuration.

- RS-232/485 serial interface
- SERCOS fiber optic multi-axis interface
- Single axis programmable positioning
- Removable Personality parameters
- Field upgrade of drive software

Analog, incremental digital, serial, or optionally SERCOS digital fiber optic or programmable command sources for shaft torque, velocity, or position control.

16 different emulated quadrature encoder output resolutions up to 16,384 PPR.

CE marked

1.2. Standard Features

In addition to the above distinctive features the SCE900 family's many industry standard features include:

Integral power supply with totally enclosed panel mount packaging.

Single resolver motor feedback survives hostile environments.

Extensive protection circuits and diagnostics to ease set-up.

IGBT power stage with inaudible high frequency PWM.

1.3. Option Cards

Option cards extend the base SCE900 functionality and allow the operating adjustments and parameters to be set. The drive is shipped from the factory unconfigured. The first step in using a drive is to set the parameters by configuring the drive. These "personality" adjustments or parameters can be stored in the base SCE900's non-volatile EEPROM memory or in the option card's non-volatile EEPROM memory. If the personality is stored in the base SCE900, the option card can be removed after setting the parameters and a blank panel substituted to lower the installed cost or to prevent un-authorized changing of drive personality in the field.

The EEPROM has a minimum life of 100,000 writes with 1,000,000 being typical. When a drive powers up, it always loads the parameters from the internal non-volatile memory. If there is an option card plugged in at power up and the internal non-volatile memory is unconfigured, the drive checks the parameter memory on the option card and, if configured, loads those parameters instead. This allows the drive's parameter personality to reside on the removable option card, allowing easy replacement of a broken base servo and keeping the custom parameters of that axis without downloading from a PC. If the internal non-volatile memory is not configured and there is no option card or the option card's non-volatile memory is unconfigured, the drive displays "U C" on the status LED and will not allow the power output to be enabled.

For additional information on configuring a base SCE900 to operate without an option card plugged in, see the *MA930 – OC930 Hardware and Software Reference Manual*.

Available option cards include:

OCE900-001	Blank panel to cover option slot
OCE930-001-00	Serial Communications Option Card RS-232 or RS-485 to set parameters
OCE940-001-01	SERCOS Option Card Industrystandard LAN fiber optic interface forcommand and to set parameters
OCE950-50x-01	Standard Single Axis ProgrammablePositioning Option Card
OCE950-60x-01	Enhanced Single Axis ProgrammablePositioning Option Card

2. MODEL IDENTIFICATION

2.1. Basic Order Numbering System

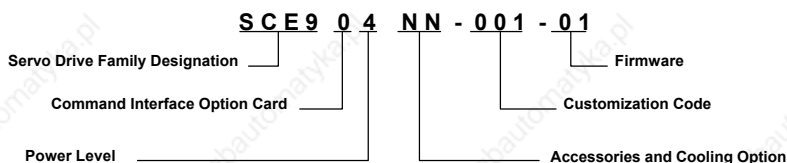

2.1.1. Part Number Designation

Servo Drive Family Designation	SCE9	
Command Interface Option Card	0	No option card installed, No communications/setup interface Analog or Incremental Digital Command
	3	ICE930-001-00 installed, RS-232/485 Serial Communications Analog, Incremental Digital, or Serial Command
	4	OCE940-001-01 installed, SERCOS interface Communications and Control
	5	OCE950-50x-01 installed, Single-Axis Programmable Positioning
Power Level	2	3.75 A continuous at 25°C, 7.5 A peak (see Section 8 for details)
	3	5.3 A continuous at 25°C, 10.6 A peak (convection cooling) 5.3 A continuous at 50°C, 10.6 A peak (forced air cooling)
	4	10.6 A continuous at 25°C, 21.2 A peak (convection cooling) 10.6 A continuous at 50°C, 21.2 A peak (forced air cooling)
	5	15.9 A continuous at 25°C, 31.8 A peak (convection cooling) 15.9 A continuous at 50°C, 31.8 A peak (forced air cooling)

Accessories and Cooling Option	<p>Nx Includes appropriate option card setup or development environment. No manuals or connectors.</p> <p>Tx All manuals for base unit and selected option card. All connectors for base unit and selected option card. All software for selected option card.</p> <p>xN No fan, convection cooled</p> <p>x1 120 VAC fan, forced air cooled</p> <p>x2 240 VAC fan, forced air cooled</p>
Customization Code	<p>001 Standard unit</p> <p>Note: The following customization codes are only valid when ordering an SCE950.</p> <p>501 OCE950 32Kx8 NV RAM, without PacLAN</p> <p>502 OCE950 128Kx8 NV RAM, without PacLAN</p> <p>503 OCE950 32Kx8 NV RAM, with PacLAN</p> <p>504 OCE950 128Kx8 NV RAM, with PacLAN</p> <p>601 OCE950 32Kx8 NV RAM, without PacLAN*</p> <p>602 OCE950 128Kx8 NV RAM, without PacLAN*</p> <p>603 OCE950 32Kx8 NV RAM, with PacLAN*</p> <p>604 OCE950 128Kx8 NV RAM, with PacLAN*</p> <p>* Enhanced firmware version</p>
Firmware	<p>01 Standard</p>

2.1.2. Example Order Numbers

Order #	Model #	Description
SCE934TN-001-01	SCE904-001-01	21.2 A peak standard servo drive
	OCE930-001-00	Serial port option card
	CAE904-TB	TB adapter SCE904 connector kit
	MAE900	<i>SCE900 Family Hardware ReferenceManual</i>
	MA930	<i>OC930 Hardware and Software ReferenceManual, 930 Dialogue 3.5"</i> floppy for PC
SCE904AN-001-01	SCE904-001-01	21.2 Amp peak standard servo drive
	CAE904	Basic SCE904 connector kit
	MAE900	<i>SCE900 Family Hardware ReferenceManual</i>
SCE934NN-001-01	SCE904-001-01	21.2 A peak standard servo drive
	OCE930-001-00	Serial port option card
SCE954NN-503-01	SCE904-001-01	21.2 A peak standard servo drive
	OCE950-503-01	OCE950 programmable option card with 32Kx8 NVRAM and PacLAN™

2.2. Accessories

2.2.1. Plug-in Cards

- | | |
|---------------|--|
| OCE900-001 | Blank option panel to cover an unused option card slot. |
| OCE930-001-0x | Serial communication option card to provide RS-232/485 communications for setup or for command. Suffix -00 is standard, -01 includes base servo drive software upgrade. This option card also allows removable personality functionality. Includes 3 1/2 floppy disc for 930 dialogue, the PC communications software. |
| OCE940-001-01 | SERCOS interface™ option card to provide command and setup over the industry standard SERCOS fiber optic ring. |
| OCE950-50x-01 | Standard Programmable Positioning option card to provide programmable single axis motion control. |
| OCE950-60x-01 | Enhanced Programmable Positioning option card to provide programmable single axis motion control. The Enhanced version of the OC950 supports additional features, including MODBus, Allen-Bradley DF-1 communications, and camming functionality. |

2.2.2. Connector Mate Kits

- | | |
|-----------|--|
| CAE90x | Screw terminal and d-subminiature mates for the SCE90x servo drive. x = 2, 3, 4, or 5 to indicate base drive power level. |
| CAE90x-TB | Screw terminal and d-subminiature terminal block adapter mates for the SCE90x servo drive. x = 2, 3, 4, or 5 to indicate base drive power level. |

2.2.3. Forced Air Cooling

- | | |
|------------|---|
| OFE90x-00x | Bottom mounting force air cooling fan and bracket accessory kit for the SCE9x4/9x5. Option suffix -002 is the standard 240 VAC 50/60 Hz model and suffix -001 is a 120 VAC 60 Hz model. |
|------------|---|



A fan is not necessary for the SCE9x3.

2.2.4. *Manual and Documentation Kits*

MAE900	<i>SCE900 Family Hardware Reference Manual</i> for the SCE900 series base servo drives.
MA930	<i>OC930 Hardware and Software Reference Manual</i> for the OC930 serial communications/setup option card.
MA940	<i>OC940 Hardware and Software Reference Manual</i> for the OC940 SERCOS interface option card.
MA950-IDE	<i>OC950 Installation and Hardware Reference Manual</i> and <i>950 BASIC Reference Manual</i> for the OC950 single-axis programmable positioning option card. Includes 3 ½ PC floppy for 950IDE Integrated Development Environment.

3. SPECIFICATIONS

3.1. Output Power

	SCE9x3	SCE9x4	SCE9x5
Peak Output Current (O-p)			
5 seconds, up to full 50 °C (A)	10.6	21.2	31.8
Continuous Output Current (O-p)			
25 °C convection cooling (A)	5.3	10.6	15.9
50 °C forced air cooling (A)	N/A	10.6	15.9
50 °C convection cooling (A)	3.5	7.1	10.6
Peak Output Power			
At 400 VAC			
1 second, up to full 50 °C (kW)	5	10	15
At 480 VAC	10.6	21.2	31.8
1 second, up to full 50 °C (kW)	5	12	18
Continuous Output Power			
At 400 VAC, three phase			
25 °C convection cooling (kW)	2.5	5.0	7.5
50 °C forced air cooling (kW)	N/A	5.0	7.5
50 °C convection cooling (kW)	2.1	3.3	5.0
At 480 VAC, three phase			
25 °C convection cooling (kW)	3.0	6.0	9.0
50 °C forced air cooling (kW)	N/A	6.0	9.0
50 °C convection cooling (kW)	2.5	3.9	6.0
Power Stage Efficiency			
At P_{continue} (%)	996	97	97
Shunt Regulator Power			
Peak Power (350 ms) (kW)	8	16	16
Continuous Power			
25 °C convection cooling (W)	25	100	200
50 °C forced air cooling (W)	N/A	125	250
50 °C convection cooling (W)	20	100	200
Maximum external regen duty cycle (%)	10	10	10
Bus Capacitance Energy Absorption			
From 650 V nominal bus (480 VAC) (joules)	27	50	80
Output Current Ripple Frequency f_r (kHz)	20	20	20
Minimum Motor Inductance I-I (mH)	4.0	2.0	1.3
Maximum Motor Inductance I-I (H)	4	2	1
Maximum Motor Power Cable Length	50 m/164 ft		
Conformance	EMC Directives 89/336 EEC		

3.2. Input Power

The SCE9x3/4/5 are capable of direct line operation. All units are fully isolated and do not require external isolation transformers. Also, the inrush current on connection to the line is internally limited to a safe level for the drive. There are no voltage selection or ranging switches required to operate within the specified voltage input ranges. It is the responsibility of the user to supply appropriate fuses or circuit breakers in the J1 AC Power motor power lines to comply with local electrical codes.

The control input power required depends on the option card plugged in and the load on user +5 VDC. It should be between 15 and 30 watts. The AC input motor power depends on output power and the losses in the power stage. The control power input has a single fuse in line with one of the AC line inputs.

3.2.1. SCE900 Control Power Supply

Model	Input Voltage Range
SCE9x3	90-264 VAC, 47-63 Hz single-phase
SCE9x4	
SCE9x5	

3.2.1.1. RIDE THROUGH TIME FOR AC LINE DROP

90 VAC 50 Hz	1 50 Hz cycle
120 VAC 60 Hz	2.5 60 Hz cycles
240 VAC 60 Hz	10 60 Hz cycles

3.2.1.2. SCE900 MOTOR AC POWER SUPPLY

Model Number	Voltage Range (VAC)	Phases	Transformer Suggested (kVA)	Maximum AC Line* (kVA)
SCE9x3	180-528	3	5	100
SCE9x4	180-528	3	8	250
SCE9x5	180-528	3	12	250

*Maximum AC Line is specified to limit the line surges coupled to the drive.

3.2.1.3. BUS VOLTAGE (NOMINAL, STANDARD DRIVE)

480 VAC Three Phase Input	650 VDC
400 VAC Three Phase Input	540 VDC
240 VAC Three Phase Input	320 VDC

3.3. Performance Characteristics



Unless otherwise specified, the below specifications are worst case limits and apply over the specified operating ambient temperature and over the specified operating line voltage.

3.3.1. Motor Current Control

Motor Phase Current Waveform	Back EMF Matched Pseudo Sine
Motor Shaft Torque (ignoring motor magnetic saturation)	
Peak	$(K_t O-p) * 0.866$ (Drive I _{Peak} O-p)
Instantaneous	$(K_t O-p) * 0.866 * IFB$
Bandwidth	
Maximum Bandwidth (kHz)	1.5
Recommended Bandwidth (kHz)	1.0
Bandwidth Variation for Fixed Motor L (%)	±10
Bandwidth Variation for ±25%	
AC Line Variation (%)	±2
Update Period (μs)	62.5
Recommended Motor Electrical Frequency (Hz)	400

3.3.2. Analog Command

Maximum Differential Range (volts)	±13.5
Maximum Single-Ended Range (volts)	±21
Full Scale Tolerance (%)	±5 (worse-case)
Linearity	±1 (typical)
Monotonic to	0.1% Full Scale
S/N Ratio Referred to Full Scale	< 2 ⁻¹⁶ Full Scale
Full A/D Bandwidth (bits)	14
150 Hz A/D Bandwidth (bits)	16
10 Hz A/D Bandwidth (bits)	18
Offset	Adjustable to 0
Maximum Unadjusted Offset (mV)	50
Offset Drift	250 μV/°C (typical)
CMRR	> 30 dB at 60 Hz

3.3.3. Digital Position Commands

Modes	Quadrature Encoder, Step And Direction, Or Up And Down Count
Maximum Input Rate For Fast Decode	
Quadrature Decode Max Line Frequency (kHz)	800
Step/Dir Decode Max Step Frequency (kHz)	800
Up/Dn Count Max Frequency (kHz)	800
Minimum Fast Decode Pulse Width (μ s)	0.6
Fast Decode Direction Setup Time (μ s)	0.6
Fast Decode Direction Hold Time (μ s)	0.6
Relative Timing for Filtered Decode	4, 8, or 16 to 1 (e.g., Max Step Freq. 800, 200, 100, or 50 kHz)

3.3.4. Velocity Loop

Maximum Stable Bandwidth	> 400 Hz
Update Period (μ s)	250
Range (rpm)	0 to 21,000
Command Resolution (rpm)	< 0.001
Velocity Loop Compensation Parameters	
KVP Range (Depends on I_{peak})	0 to 12.6 * (I_{peak}) amps/(rad/sec)
KVP Resolution (bit)	16
KVI Range (Hz)	0 to >200
KVI* Resolution (bit)	16
ARF0* Range (Hz)	0.01 to >1e5
ARF1* Range (Hz)	0.01 to >1e5
ARZ0* Range (Hz)	20 to >1e5 or off
ARZ1* Range (Hz)	20 to >1e5 or off
CMDGAIN Range (rpm/V)	0 to \pm 15,000
CMDGAIN Resolution (bit mantissa)	\geq 16

* ARx0 set to a negative number allow complex poles/zeros. In this case, ARx1 becomes the Q and the corresponding ARx0 is the frequency in Hz.

3.3.5. Position Loop

Maximum Bandwidth (Hz)	> 100 Hz
Update Period (ms)	1
Position Range (rev)	1 to \pm 32768
Position Error Range (rev)	0 to \pm 4500
Command Resolution	2^{-16} rev – 0.3 arc min
Position Loop Compensation Parameters	
KPP Range (Hz)	0 to 200
KPP Resolution (bit)	16
KVFF Range (%)	0 to 199.9
KVFF Resolution (bit)	16

3.3.6. General

Max Delay AC Line to Control Supply On (sec)	0.75
Max Delay AC Line to Fully Operational (sec)	2.0

(Fully operational by "A" of "PACSCI" LED status message)

3.3.7. Environmental

Operating Ambient Temperature Convection Cooling	
Full Ipeak/2 continuous rating (°C)	0 to 25
Linearly derate Ipeak/2 continuous rating per $(1 - (T - 25\text{°C})/75\text{°C})$ (°C)	25 to 60
Operating Ambient Temperature Forced Air Cooling	
Full Ipeak/2 continuous rating (°C)	0 to 50
Linearly derate Ipeak/2 continuous rating per $(1 - (T - 50\text{°C})/30\text{°C})$ (°C)	50 to 60
Storage Temperature (°C)	-40 to 70
Humidity, non-condensing (%)	10 to 90
Altitude	1500 m (5000 ft)

3.3.8. Mechanical

The SCE900 packaging is totally enclosed single axis panel mount.

3.3.9. Size

Model	Height	Width	Depth
SCE9x3	370 mm/14.5"	85 mm/3.3"	229 mm/9.0"
SCE9x4	370 mm/14.5"	114 mm/4.5"	229 mm/9.0"
SCE9x5	370 mm/14.5"	160 mm/6.3"	229 mm/9.0"

The OF90x optional fans mount below the units and are slightly larger than the 93 mm (3.65") width and 25 mm (1.0") thickness of the fan itself.

3.3.10. Weight

Model	Weight
SCE9x3	5.0 kg/11 lb.
SCE9x4	6.6 kg/14 lb.
SCE9x5	9.5 kg/20 lb.

3.4. Resolver Feedback



Unless otherwise specified, these specifications are worst-case limits and apply over the specified operating ambient temperature and operating line voltage.

3.4.1. Resolver Position Signal

Resolution/Rev	24 Bits -> 0.0013 arc min
Repeatability	$< \pm 2^{-18}$ Rev = ± 0.08 arc min rms
Noise	
No Filtering	$< 2^{-16}$ rev rms = 0.3 arc min rms
150 Hz Single Pole Filtered	$< 2^{-17}$ rev rms = 0.16 arc min rms
10 Hz Single Pole Filtered	$< 2^{-19}$ rev rms = 0.04 arc min rms
DC Offset Temperature Drift	2^{-18} rev/ $^{\circ}$ C = 0.08 arc min/ $^{\circ}$ C
Absolute Accuracy	
Drive Only	$\pm 2^{-12}$ rev = ± 5.3 arc min
Drive with 20 arc min resolver	$\pm 2^{-9.75}$ rev = ± 25 arc min
Software Update Time (RMS)	1

3.4.2. Resolver Velocity Signal

Resolution (rpm)	< 0.001
Quanta (rpm)	< 0.0142
Noise	
No Filtering (rpm RMS)	< 3
150 Hz Single Pole Filtered (rpm RMS)	< 0.6
10 Hz Single Pole Filtered (rpm RMS)	< 0.06
DC Accuracy	
Typical at 25 $^{\circ}$ C (%)	± 0.01
Worse case (%)	± 0.05
Ripple	
Drive Only (% p-p at 1000 rpm)	0.75
Drive with 20 arc min resolver (% p-p at 1000 rpm)	3
Offset (rpm)	0.0001
Software Update Time (μ s)	250

3.4.3. Emulated Encoder Output Signals

Available Resolution (PPR)	
Binary	128, 256, 512, 1024, 2048, 4096, 8192, 16384
Decimal	125, 250, 500, 1000, 2000, 4000, 8000, 16000
Maximum Output Line Frequency (Hz)	833
Max Recommended Speed at 16384 PPR (rpm)	2900
Max Recommended Speed at 4096 PPR (rpm)	11600
Marker Plus Width	~1 Quadrature Pulse

3.4.4. General

-3 dB Bandwidth (Hz)	> 2000
-45° Phase Lag (Hz)	> 500
Resolver Excitation Frequency (Hz)	6510.42
Max Tracking Rate (rpm)	> 48600
Max Recommended Rate (krpm)	25
Max Tracking Acceleration (rpm/sec)	< 16×10^6
Max Feedback Cable Length (m/ft)	50/164

3.5. Use Conforming with Requirements

The equipment described herein has been developed, produced, tested and documented in accordance with the corresponding standards. During use conforming with requirements, the equipment is not dangerous for people or equipment. Use conforming with requirements means that the safety recommendations and warnings detailed in this manual are complied with and that the applicable regulations for safety (machine directives, etc.) and noise suppression (EMC Directives) are observed while operating the drive.

At the end of its lifetime, dispose of or recycle the drive according to the regulations applicable at that time.

3.6. CE Approval

The CE initials confirm that the SCE903, SCE933, SCE904, SCE934, SCE905 and SCE935 drives satisfy all requirements of CE Directives.

The equipment is not ready to operate without additional installations (cable, motor, etc.). Thus, all necessary tests and measurements had to be made on a typical installation. The test installation with all peripheral devices, as well as the test results and measurements are recorded in detail in documentation that is available from the manufacturer on request. The test installation, to which the Declaration of Conformity refers to, is noted in European Directives.



If the connection method on your machine is different from the one described in European Directives, or in the event of use of components other than those that we have specified, adherence to interference limit values cannot be guaranteed.

3.6.1. Declaration of Conformity

In our Declaration of Conformity, we affirm our compliance with Directive 73/23/EEC (Low voltage Directive) and with Directive 89/336/EEG (EMC Directive). During assembly of our product in a machine, startup (that is, normal operation) is prohibited until the end-product complies with Directive 89/392/EEC (Machine Directive) and directive 89/336/EEC (EMC Directive).

The machine manufacturer must prove that the complete system conforms with all relevant European Directives. Drive conformance to specified standards is certified by the Declaration of Conformity.

3.6.2. Declaration of Conformity Certificate

CE Declaration of Conformity

This is to certify that:

EDUARD BAUTZ Antriebstechnik GmbH
Subsidiary Pacific Scientific Corporation
Robert Bosch Straße 10
64331 Weiterstadt
Germany

Declares that the product(s):

Designation *SERVO DRIVES*

Type *SCE903, SCE933, SCE904, SCE934, SCE905, SCE935*

are in conformity with requirements of:

EC- Directive *89/336/EEC* *Electromagnetic Compatibility*

Applied harmonised standards: *EN 50081.2 Parts 1.1, and 1.2,
EN 50082.2 Parts 1.1, 1.4., 2.1., 2.2., 3.1, 3.2., 5.1.5.2., 6.1.*

EC- Directive *72/23/EEC* *Low Voltage Directive*

Applied harmonised standards: *EN 60204.1, prEN 50178*

Applied national standards: *VDE 0160*

First marking with CE- Sign: '96

Issued By: BAUTZ Antriebstechnik GmbH
Dipl.-Ing. Norbert Witsch

Place, Date: Weiterstadt, 04.04.1997

Legally binding
Signature



Geschäftsführer:
Dipl.-Ing. Norbert Witsch

Handelsregister Darmstadt Nr.: 8 HRB 1045
Sitz: 64331 Weiterstadt

4. INSTALLATION

4.1. Installation and Commissioning

Installation and wiring of the drive must be completed only by qualified personnel having a basic knowledge of electronics, installation of electronic and mechanical components, and all applicable wiring regulations.

Commissioning of the machine utilizing the drives must be done only by qualified personnel having broad knowledge of electronics and motion control technology.

4.2. Safety Requirements

4.2.1. *Your Responsibility*

As the user or person applying this unit, you are responsible for determining the suitability of this product for the application. In no event will Danaher Motion Pacific Scientific be responsible or liable for indirect or consequential damage resulting from the misuse of this product.

Read this manual completely to effectively and safely operate the SCE900 series unit.

4.2.2. *European Directives*

Comply with the applicable European standards and Directives. In Germany these include:

DIN VDE 0100 (instructions for setting up power installations with rated voltages below 1000 V).

DIN - EN 60 204 - Part 1, (VDE 0113, part 1) instructions relative to electric equipment in machines for industrial use.

prDIN EN 50178, (VDE 0160) equipping high-voltage current installations with electronic operating means.

4.3. Installing the SCE900 Drive

Much of the connection information presented in this section is summarized in the figures on the following page.

4.3.1. Mounting the Drive

The SCE900 drives are designed for operation in a cabinet. Follow these installation instructions:

1. Mount the drives vertically inside a cabinet on a flat, solid, electrically conductive, mounting surface which is connected to PE (protective earth ground) and is capable of supporting the weight of the unit.
2. Remove the paint on the back of the drive as well as on the mounting surface over an area extending at least 12 mm (0.5") from the mounting bolts to achieve good electrical connection over a large area between the drive and grounded mounting surface.
3. Install conductive clamps near the drive on the mounting panel (ground plane) for electrically connecting the outer shield of certain cables (defined below) to the panel. Remove about 10mm (0.5") of the outer jacket of these cables where the clamp will be to expose the braided shield before inserting under the clamp and tightening. The length of the cable between the drive connection and the clamp should be as short as possible not exceeding 0.6 meters (two feet). If a ground plane is available at the other end of these cables, use a conductive clamp at that end to connect the shield to that ground plane as well.
4. Provide a minimum unobstructed space of 100 mm (4") above and below the drive. With convection cooling, provide 40mm (1.6") free space on either side of each unit. With forced air cooling, no free space is required on either side of each unit.
5. Insure the environment within the cabinet meets the requirements defined on page 3-5.

4.3.2. 9x3 CE Block Diagram

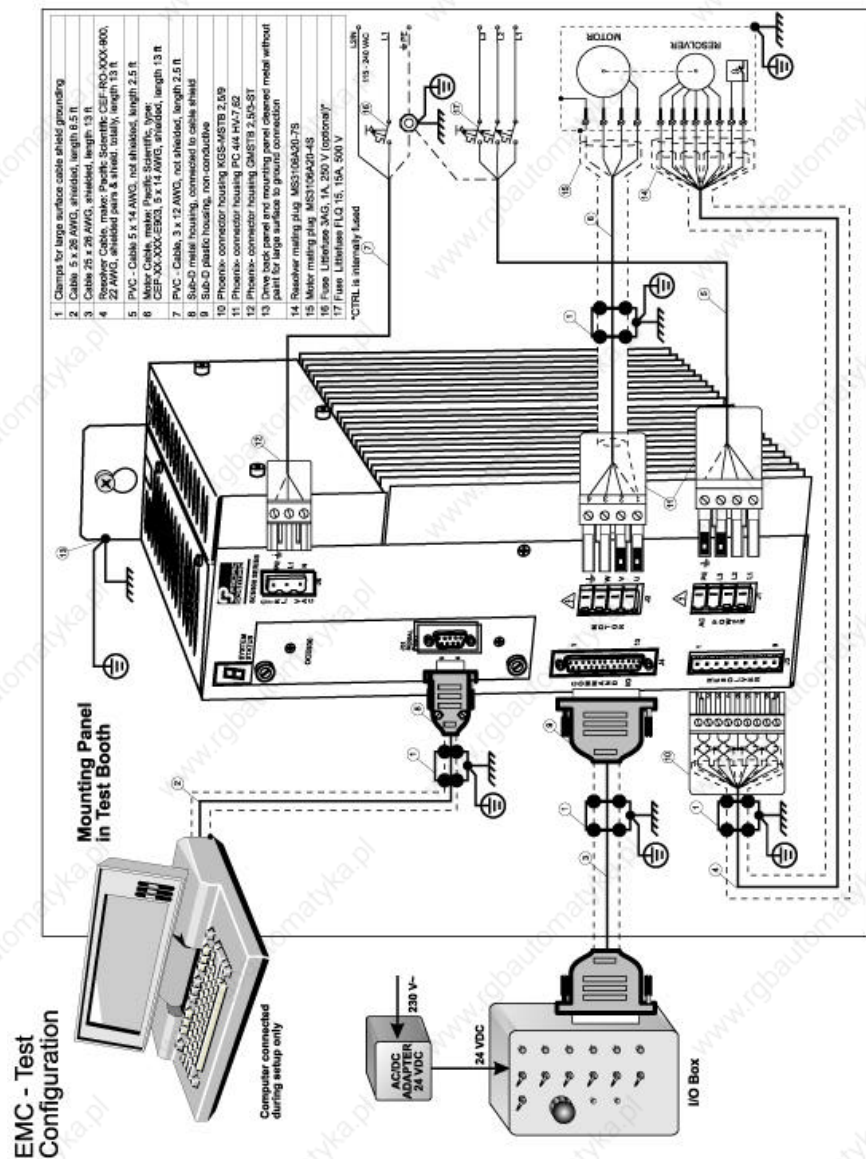

4.3.3. 9x4 CE Block Diagram

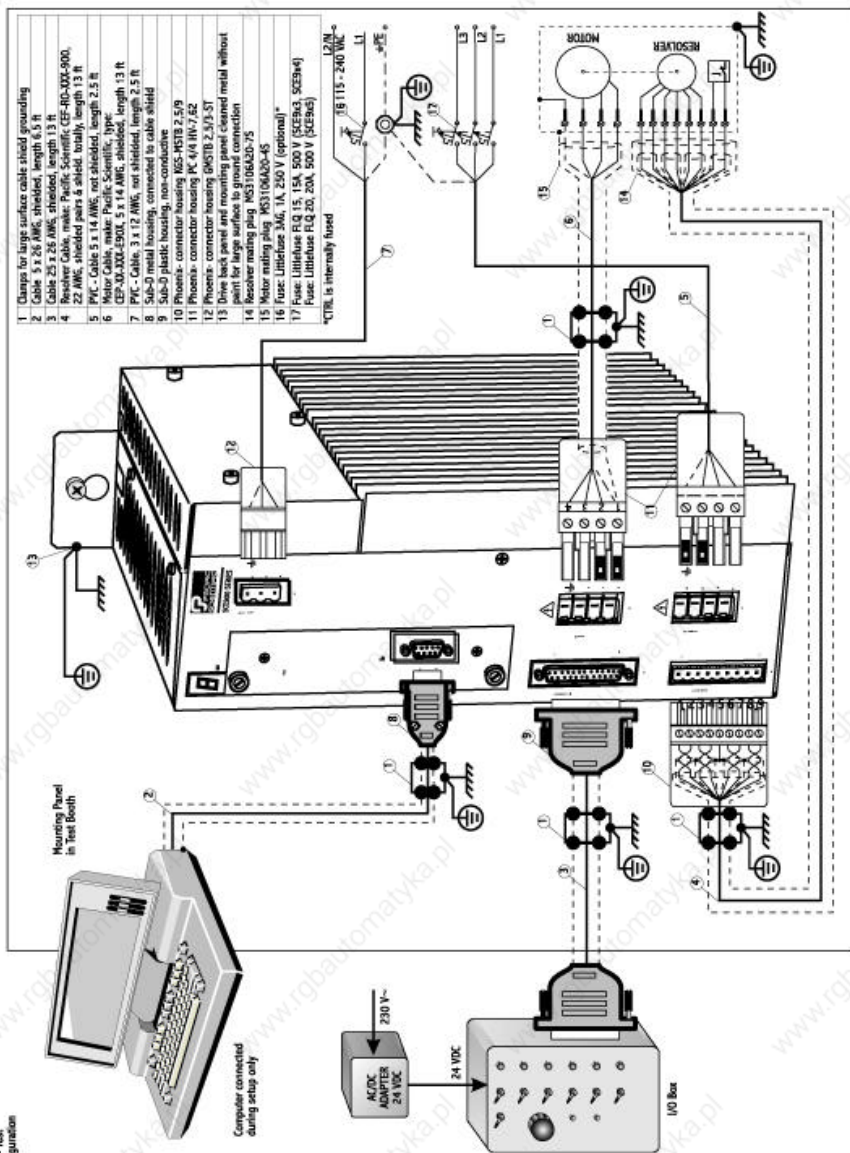

4.3.4.1. MOUNTING GUIDELINES

The next figures give the key dimensions for use in physically mounting the product. When mounting multiple drives in a row some customers have found the stiffness of the drive and their mounting panel to be too low. To increase the mounted mechanical integrity, connect to the threaded insert on the top front edge.

The overall drive panel dimensions and the mounted depth not including mating connectors is listed in the below chart. The extra depth for mating connectors is 1.0" or less.

4.3.4.1.1. SCE9x3 Outline Dimensions

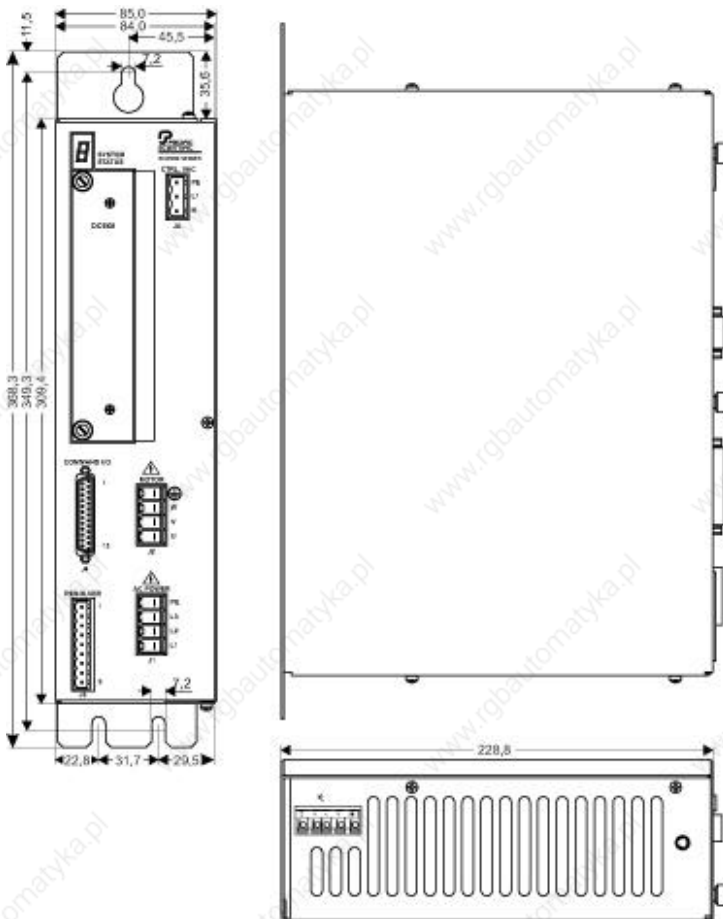

4.3.4.1.2. SCE9x4 Outline Dimensions

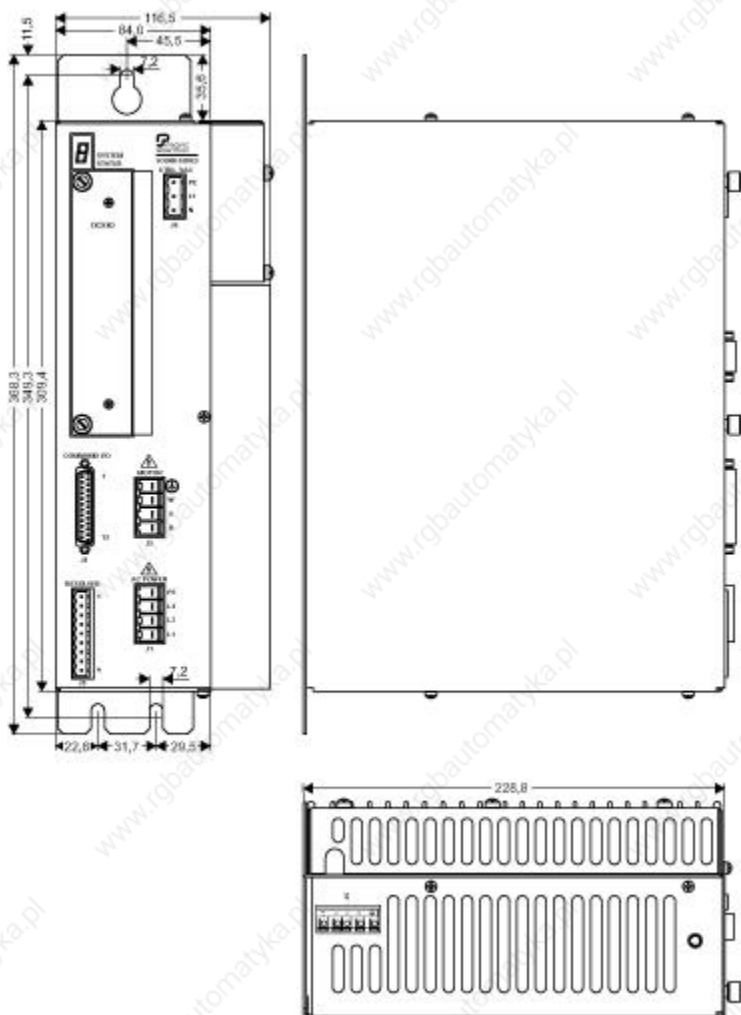

4.3.4.1.3. SCE9x5 Outline Dimensions

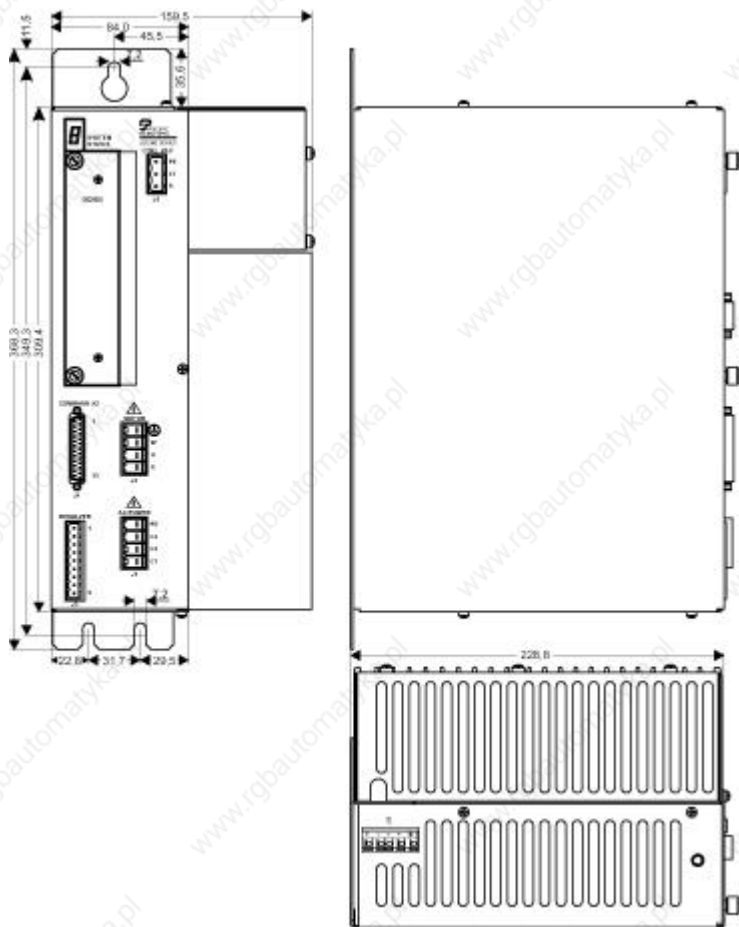

4.3.4.2. CONNECTING AC POWER

The SCE900 series drives, with the exception of the SCE902, are functionally compatible with all standard forms of three-phase AC lines:

- Grounded neutral WYE
- Open-Delta Grounded Leg
- TEE

However, the internal CE EMI filter is optimized for the grounded neutral WYE AC lines that are standard in Europe. Connection to other AC line types can exceed the conducted EMI limits set by CE. Danaher Motion Pacific Scientific recommends that all machine CE compliance testing be done with a grounded neutral WYE AC line.

4.3.4.2.1. AC Power

The AC power source for connector J6 (control power supply) can be either single phase 115-240 VAC referenced to neutral (PE) or a symmetrical 115-240 VAC to neutral.

4.3.4.2.2. Fusing

Use slow blow fuses in series with J1 pins 1, 2, and 3 as shown in the CE Block Diagrams.

4.3.4.2.3. J1

Model	Fuse
SCE9x3	10 A, 500 V, midget, Slo-Blo [®] , 1½ x 13/32", FLQ 10
SCE9x4	15 A, 500 V, midget, Slo-Blo [®] , 1½ x 13/32", FLQ 15
SCE9x5	20 A, 500 V, midget, Slo-Blo [®] , 1½ x 13/32", FLQ 20

4.3.4.2.4. J6

Use slow blow fuse in series with J6 pin 2 as shown in the CE Block Diagrams.

Fuse
1 A, 250 V, Slo-Blo [®] , 1 x ¼ 3AG
1 A, 250 V, Slo-Blo [®] , 1½ x 13/22, FLM 1

4.3.5. Connection to PE Ground

Because the leakage current to protective ground through the drive's internal line filter is approximately 15mA the following measures must be taken to comply with the European Low Voltage Directive EN50178:

J1 pin 4 and J6 pin 1 must both be connected to Protective Earth ground (these pins are each marked with the PE symbol) utilizing separate leads for redundancy. The connection at the Protective Earth ground end must be hard wired (not utilize pluggable connections)

A ground fault detector (RCD) can **not** be depended upon for safety.

4.3.6. Grounding Shields for Safety & Low Emissions/Susceptibility

Dangerous voltages, resulting from cable capacitance, exists on some cable shields if the shields are not connected to PE ground. Proper grounding of shields is also required to reduce radiated and conducted emissions as well as to protect against susceptibility to external and self generated noise. Follow these shielding requirements carefully:

The drive end of the motor cable shield must be connected to the PE pin on the J2 connector. The shield must also be clamped to the ground plane as described above. If cable with a separate inner foil shield and outer braided shield is used (Danaher Motion Pacific Scientific CE cables for example), connect the foil shield to the PE pin on the J2 connector and clamp the outer braided shield to the ground plane. If the leads for a motor holding brake are run with the motor leads, the holding brake leads must be separately shielded and the shield connected to the PE pin on the J2 connector.

The resolver cable should have inner shields around each twisted pair as well as an overall outer braided shield. The inner shields should be connected to J3 pin 5 while the outer shield should be clamped to the ground plane.

The control leads to the J4 connector should have an outer braided shield with the shield clamped to the ground plane.

If an external regen resistor is used, the leads between the drive and resistor must be shielded with the shield clamped to the ground plane.

4.3.7. *Grounding the Motor Case*

Insure that the motor's case is connected to PE ground. This is accomplished by the fourth wire in the motor cable connecting J2 pin 1 to the motor case.

If the motor is not properly grounded, dangerous voltages can be present on the motor case due to capacitive coupling between the motor windings and case.

4.3.8. *Long Motor Power Cables*

The SCE900 drives do not require additional filtering in the motor leads as long as the motor power cable (between drive connector J2 and the motor) is less than 10 meters (32 feet) long. For longer motor power cables, an external filter must be added in series with the cable. Additional information can be found in Application Notes 106 ("Reducing Motor Drive Line Noise") and 107 ("Reducing Motor Drive Radiated Emissions").

4.4. Requirements for Safe Operation of the Drive

It is the machine builder's responsibility to insure that the complete machine complies with the Machine Directive (EN60204). The following requirements relate directly to the servo controller:

4.4.1. *Emergency Stop*

If personal injury can result from motor motion, the user must provide an external hardwired emergency stop circuit outside the drive. This circuit must simultaneously remove power from the drive's motor power connector J1 and disable the drive (by disconnecting J4 pin 6 from I/O RTN).



The motor coasts under this condition with no braking torque.

If braking torque is required to quickly stop the motor, a dynamic brake can be added that loads the motor's windings resistively. The motor should not be loaded until the servo drive is disabled. Note that the holding brake which is optional on Pacific Scientific motors is not intended to stop a spinning motor. It is designed to prevent a stopped motor from rotating due to an applied torque.

4.4.2. *Avoiding Unexpected Motion*

Always remove power from J1 before working on the machine or working anywhere where injury can occur due to machine motion.

4.4.3. *Avoiding Electrical Shock*

Never power the servo drive with the cover removed or with anything attached to circuitry inside the cover.

If the drive must be removed from the cabinet, wait at least five minutes after turning off power before removing any cables from the drive or removing the drive from the mounting panel.

Never plug or unplug any connectors to the drive while power is applied. Always power down and wait five minutes before connecting or disconnecting any wires to the terminals.

4.4.4. *Avoiding Burns*

The temperature of the drive's heat sink and housing as well as an external regen resistor can exceed 70°C. Therefore, there is a danger of severe burns if these regions are touched.

4.5. **Preventing Damage to the Drive**

Follow these guidelines to prevent damage to the servo drive during operation:

Never plug or unplug connectors with power applied.

Never connect or disconnect any wires to terminals with power applied

Never plug or unplug an option card with control power applied

If the drive is powered up and then powered down, wait at least three minutes from the previous power-up before re-applying power. This allows time for the surge limiting circuitry to recover which avoids high inrush currents.

If the drive indicates a fault condition, find the cause of the fault and fix it prior to resetting the fault or power-cycling the drive.

5. I/O TERMINATIONS

All terminations on the SCE903, SCE904 and SCE905 drives are two piece pluggable connections. Also, all connectors are unique or keyed such that a cable can not be plugged into the wrong location or plugged in backwards.

In the list below an overbar on a signal name means that the signal is active low logic. For example, “Enable” enables the drive when this input is pulled low and disables the drive when it is high.

Chassis Grounding Stud, M5-12 with nut and lock washer.

5.1. SCE900 Power Board Connectors

5.1.1. J1 AC Power

7.62 mm Pluggable TB	
Pin	Description
L1	480 VAC (Input)
L2	480 VAC (Input)
L3	480 VAC (Input)
PE	CHASSIS GROUND

5.1.2. J6 Control Power

5.08 mm Pluggable TB	
Pin	Description
N	240 VAC / 120 VAC CONTROL POWER (Input)
L1	240 VAC / 120 VAC CONTROL POWER (Input)
PE	CHASSIS GROUND

7.62 mm Fixed TB	
Pin	Description
U	MOTOR PHASE U (Output)
V	MOTOR PHASE V (Output)
W	MOTOR PHASE W (Output)
PE	MOTOR CASE GROUND

5.1.3. J5 Regeneration Interface

5 mm Spring Clip TB	
Pin	Description
PE	CHASSIS GROUND
2	- BUS (Output)
3	INTERNAL REGEN RESISTOR (Input)
4	REGEN RESISTOR (Output)
5	+ BUS (Output)

5.2. SCE900 Base Servo Drive User I/O Connections

5.2.1. J3 Feedback

5.0 mm Pluggable TB	
Pin	Description
1	RESOLVER S1 SIN + (Input)
2	RESOLVER S3 SIN - (Input)
3	RESOLVER S2 COS + (Input)
4	RESOLVER S4 COS - (Input)
5	SHIELD (I/O RTN)
6	RESOLVER R1 EXCITATION (Output)
7	RESOLVER R2 EXCITATION RTN (Output)
8	MOTOR PTC (Input)
9	MOTOR PTC RTN (Input)

5.2.2. J4 Command I/O

25 Position D subminiature male			
Default functions for BDIOs listed in ()			
Pin	Description	Pin	Description
1	ANALOG CMD + (Input)	14	CH A OUT
2	ANALOG CMD - (Input)	15	$\overline{\text{CH A OUT}}$
3	DAC MONITOR 1 (Output)	16	CH B OUT
4	DAC MONITOR 2 (Output)	17	$\overline{\text{CH B OUT}}$
5	I/O RTN	18	I/O RTN/+5 VDC RTN
6	$\overline{\text{ENABLE}}$ (Input)	19	CH Z OUT (Output)
7	BDIO 1 ($\overline{\text{Fault Reset}}$)(Bi-directional)	20	$\overline{\text{CH Z OUT}}$ (Output)
8	BDIO 2 ($\overline{\text{CwInh}}$)(Bi-directional)	21	CH A IN (STEP +) (STEP UP +) (Input)
9	BDIO 3 ($\overline{\text{CcwInh}}$)(Bi-directional)	22	$\overline{\text{CH A IN}}$ (STEP -) (STEP UP -) (Input)
10	BDIO 4 (Mapped Off)(Bi-directional)	23	CH B IN (DIR +) (STEP DOWN +) (Input)
11	BDIO 5 (Brake)(Bi-directional)	24	$\overline{\text{CH B IN}}$ (DIR -) (STEP DOWN -) (Input)
12	BDIO 6 (Fault)(Bi-directional)	25	+5 VDC (200 mA max) (Output)
13	I/O RTN	(26)	I/O RTN on optional TB adapter mate

5.3. Drive Wiring Diagram

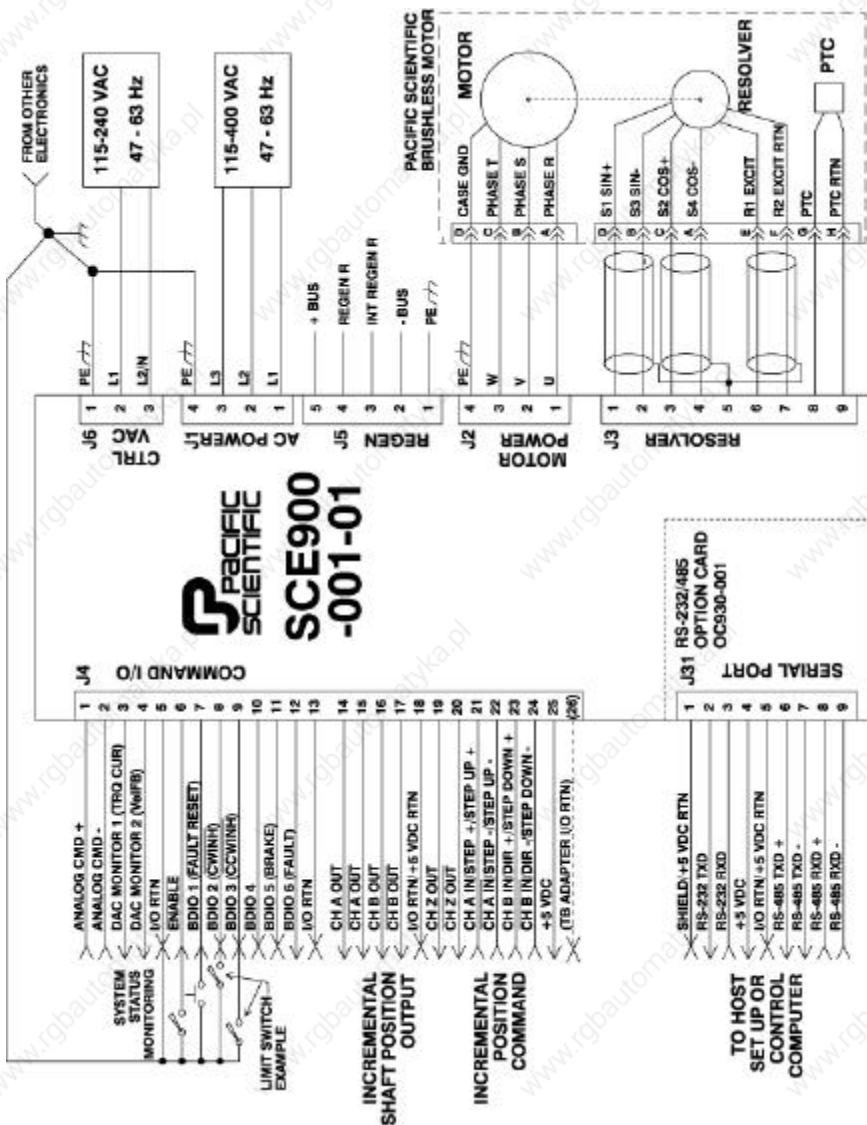

5.4. I/O Definitions

5.4.1. Chassis Ground Stud

This input provides a point for the user to connect the drive to earth ground for safety.

5.4.2. J1 AC Power

5.4.2.1. L1, L2, L3

These terminals connect the 480 VAC power provided by the user to the drive's power output stage bus to drive the motor.

5.4.2.2. CHASSIS GROUND

Convenience connector point for the user to connect the drive to earth ground. Directly connected to the chassis and thus to the Chassis Ground Stud.



Local electrical code may require using the Earth Ground Chassis stud for this function

5.4.3. J6 Control Power

5.4.3.1. N, L1

These terminals connect the 240/120 VAC power provided by the user to the drive's control voltage power supply.

5.4.3.2. CHASSIS GROUND

Convenience connector point for the user to connect the drive to earth ground. Directly connected to the chassis and thus to the Chassis Ground Stud.



Local electrical code may require using the Earth Ground Chassis stud for this function

5.4.4. J2 Motor Power

5.4.4.1. MOTOR PHASE U, V, W

These three terminations provide the 3-phase power output to the brushless motor.

5.4.4.2. MOTOR CASE GROUND

This termination provides a convenient point for the motor ground connection and motor power wire shield. Local electrical code may require using the Earth Ground Chassis stud for this function.

5.4.5. J5 Regeneration Interface

5.4.5.1. PE, INTERNAL REGEN RESISTOR, REGEN RESISTOR, - BUS, + BUS

These terminals connect the internal shunt regulator resistor or provide the connection points for an external resistor or external capacitor bank to absorb regenerated energy from the motor. An isolated wire line is fitted by the factory between terminals R and Ri, thus connecting the drive's internal regeneration resistor to the regeneration circuit output. The other end of the internal regeneration resistor is hard wired to +DC bus internally.

5.4.5.2. EXTERNAL REGEN RESISTOR

If necessary, an external regeneration resistor can be connected between terminals +DC and R. In this case, the link between Ri and R must be removed. When using an external regeneration resistor make sure that the external resistance follows the chart below within $\pm 10\%$.

Model #	Resistance
SCE9x3	80 Ω
SCE9x4	36 Ω
SCE9x5	36 Ω

The required rating of the external regen resistor is dependent upon the load and motion characteristics. These must be determined during the machine sizing analysis. High power ratings are often most easily achieved by using series or parallel connection of resistors.

5.4.6. J3 Resolver

5.4.6.1. RESOLVER S1, S2, S3, S4 INPUTS

These connections provide the inputs for the resolver's sine/cosine outputs. Differential inputs with > 75 Vms common mode impulse range and > 25 k Ω input impedance.

5.4.6.2. RESOLVER R1 EXCITATION, R2 EXCITATION RTN OUTPUTS

These connections provide the resolver excitation output. 9.2 V RMS at 6510.42 Hz 75 mA rms maximum load. These outputs are fully short circuit protected to I/O Common or to each other at room temperature (25°C), but at ambient temperatures $> 50^\circ\text{C}$ shorts longer than 5 minutes may cause damage.

5.4.6.3. MOTOR PTC, PTC RTN INPUTS

These two inputs are intended to connect to a positive temperature coefficient thermistor or normally closed thermostatic switch imbedded in the motor windings. When the resistance between these terminals becomes $> 6.2 \text{ k}\Omega$ the drive will fault and indicate a motor over-temperature fault. This circuit directly interfaces with Danaher Motion Pacific Scientific's standard motor PTC.



PTC RTN is connected to I/O RTN

5.4.7. J4 Command I/O

5.4.7.1. ANALOG CMD (+), (-) INPUTS J4-1, 2

These inputs accept the analog command from the user. This is a differential input to an A/D. It has a maximum single ended input range with respect to I/O RTN on either input of $\pm 21 \text{ V}$ and an input impedance of $> 50 \text{ k}\Omega$. The full scale differential command input range is $\pm 13.5 \text{ V}$. The offset and single pole low pass bandwidth of this signal is adjustable via a software setup parameter. When used as a motion command, the gain from this input is also adjustable via a software setup parameter.

5.4.7.2. DAC MONITOR 1, 2 OUTPUTS J4-3, 4

These analog outputs are general purpose monitor points. The output range is $\pm 5 \text{ V}$ with a resolution of $10 \text{ V}/256 = 0.039 \text{ V}$. The source impedance is $1 \text{ k}\Omega$, which yields a maximum short circuit to I/O RTN current of $\pm 5 \text{ mA}$. These outputs are updated at the Velocity Loop update rate (4 kHz). There is a 10 kHz analog LPF on these outputs.

Each DAC Monitor can be mapped by software to be one of a number of internal variables. The scale factor and the frequency of a single low pass filter pole are software adjustable on each output by the DM1Gain, DM1F0 and DM2Gain, DM2F0 software parameters for DAC Monitor 1 and 2 respectively. Variables marked with a "*" are not range clamped and are allowed to wrap around when the signal exceeds the output DAC's voltage range. The other variables will clamp at maximum when they exceed the analog voltage range. The following table lists the defined signal mappings.

5.4.7.2.1. DAC Monitor List Table

DMxMap	Variable	Description	DAC Out Units
0	AnalogOutx	Actual Analog Output Command	V/V
1	VelFB	Measured Velocity (DM2 Default)	1 V/krpm
2	VelCmdA	Actual Velocity Command (VelCmdA)	1 V/krpm
3	VelErr	Velocity Error	1 V/krpm
4	FVelErr	Compensated Velocity Error	1 V/krpm
5	Position	Measured Position*	1 V/Rev
6	PosError	Position Error*	1 V/Rev
7	PosCommand	Commanded Position*	1 V/Rev
8	Icmd	Commanded Torque Current	1 V/A
9	IFB	Measured Torque Current(DM1 Default)	1 V/A
10	AnalogIn	Filtered A/D Input	1 V/V
11	EncFreq	Encoder Frequency	1 V/Hz
12	EncPos	Encoder Position*	10 V/4096 counts
13	ItFilt	Filtered Output Current Amplitude	1 V/100%
14	HSTemp	Measured Heat Sink Temperature	1 V/°C
15		Commutation Electrical Angle*	1 V/cycle
16	IR	Motor Phase R Output Current	1 V/A
17	IS	Motor Phase S Output Current	1 V/A
18	IT	Motor Phase T Output Current	1 V/A
19		Motor Phase R Voltage Duty Cycle	1 V/100%
20		Motor Phase S Voltage Duty Cycle	1 V/100%
21		Motor Phase T Voltage Duty Cycle	1 V/100%
22	VBus	Drive Bus Voltage	1 V/V
23	ResPos	Resolver Absolute Position*	1 V/Rev
24		Commanded non-torque current	1 V/A
25		Measured non-torque current	1 V/A
26		Torque Voltage Duty Cycle	1 V/100%
27		Non-torque Voltage Duty Cycle	1 V/100%
28	VelCmd	Velocity Command (VelCmd)	1 V/krpm
65536	No change to variable selection, turn range clamp off		
65537	No change to variable selection, turn range clamp on		

*These variables are allowed to wrap around when the signal exceeds the output voltage range.

5.4.7.4. I/O RTN J4-5, 13, 18

This terminal is signal common for the analog and digital inputs and outputs.

5.4.7.5. ENABLE INPUT J4-6

This input is used to enable the drive and is active low. The output stage is disabled when this input is inactive. There is a 3.3 k Ω resistor and diode in series to the internal pull up voltage. A minimum drive sink capability of 5 mA is recommended and the maximum external pull up voltage is 30 VDC with respect to I/O RTN. This signal is detected with 1 V p-p hysteresis and a selectable center point for the logic trip thresholds which also selects the pull up voltage. With the BDLgcThr parameter set to 0 the trip voltages are 2.1 and 3.1 volts with 5 volt nominal pull-up while with BDLgcThr set to 1 the trip voltages are 4.0 and 5.0 with a 12 volt nominal pull-up. This input is filtered with a 2 ms time constant low pass filter to prevent false triggering from noise.

BDIO 1, 2, 3, 4, 5, 6
Bi-directional
J4-7, 8, 9, 10, 11, 12

These six I/O connections are user programmable discrete inputs or outputs. As outputs they are open collector with 30 volt with respect to I/O RTN and 100 mA current sinking maximum ratings. These outputs are not short circuit proof. BDIO 6 has a higher maximum current sinking rating of 200 mA. As inputs these signals are detected with 1 V p-p hysteresis and a selectable center point for the logic trip thresholds. With the BDLgcThr parameter set to 0 the trip voltages are 2.1 and 3.1 volts with 5 volt nominal pull up while with BDLgcThr set to 1 the trip voltages are 4.0 and 5.0 with a 12 volt nominal pull up. These inputs are filtered in hardware with a 20 μ s time constant low pass filter for noise suppression. On each line there is a 3.3 k Ω resistor and a diode in series to the internal pull up voltage. A minimum drive sink capability of 5 mA is recommended to fully pull these inputs to a logic low. During AC power down or during the power up reset period these lines are held in the open collector state.

Each of the BDIOs is set and read by software every 2 ms. Each one can be configured to be any of the available functions and the configuration can be changed on the fly via digital communications to an option card. The user's default configuration is stored in the non-volatile memory. The present state of each of these lines as well as the state of commanded outputs can be read via digital communications on an option card. The logic polarity of these signals is also software programmable. That is, an input or an output can be defined to be active low or active high. For edge triggered functions the active edge is programmable.

The available functions and the mapping used as the factory defaults for each BDIO are described in the following paragraphs.

$\overline{\text{Fault Reset}}$
Input

BDIO 1 This input is used to reset the amplifier following a fault. This input is programmed active low so that an open circuited input does not activate the function. During Fault Reset active, the output stage is disabled and the reset condition will be held in hardware for approximately 0.1 sec after Fault Reset is returned inactive.

$\overline{\text{CwInh}}$
Input

BDIO 2 This input prevents further motion in the clockwise shaft motion direction. If the shaft is already moving in the clockwise direction, then the motor will decelerate to zero velocity with the maximum torque allowed by the user set output current limits. This input will have no effect on motion in the counterclockwise direction. This input is programmed active low so that an open circuited input does not activate the function. This input is useful for a clockwise over travel limit switch.

Status display will alternate between 8 and $\overline{1}$ when the limit input is affecting motion.

$\overline{\text{CcwInh}}$
Input

BDIO 3 Analogous to the $\overline{\text{CwInh}}$ input, except that this input prevents counter-clockwise motion.

Status display alternates between “8” and $\overline{1}$.

Input
Mapped
Off

BDIO 4 Input Mapped Off

Brake
Output

BDIO 5 This output is high (i.e. open collector) when the control power is off, or when control voltage is on and the drive is disabled (ENABLED = 0). Otherwise, this output is pulled low. This output is intended to drive a normally open relay that in turn powers a mechanical brake on the motor shaft for applications that require a positive shaft lock when the servo drive is off.

Fault
Output

BDIO 6 This output is high (i.e., open collector) when the drive is faulted or has no control power. This line can be used to indicate a problem with the drive.

The table below lists the possible additional BDIO functions:

Function	Description
Enable2 Input	Second enable input
Run/Stop Input	Enable/bring speed to zero then disable
VelCmdSrc Input	Select one of two speeds, useful to emulate clutch/brakes
AInNull Input	Null the present Analog Cmd voltage to zero AnalogIn
Enabled Output	Indicates when the drive is enabled

CH A OUT,
CH A OUT,
CH B Out,
CH B OUT
Outputs J4-14,
15, 16, 17

These two output pairs are differential TTL incremental position signals generated by the Resolver feedback electronics. These outputs are quadrature encoder to emulate an optical encoder. The resolution of these signals, i.e. the emulated line count, is set by the EncOut parameter. These outputs are buffered by 26LS31 type RS-422 compatible line drivers. Maximum recommended load current is ± 20 mA, which corresponds to a minimum line-to-line load resistance of 100Ω . This drive capacity corresponds to 10 RS-422 compatible inputs such as the SCE900 encoder inputs. These outputs are indefinitely short circuit (to I/O RTN) proof.

CH Z OUT,
CH Z OUT
Outputs J4-19, 20

These two terminals function as a differential, TTL marker pulse. The output pulse occurs once per motor shaft revolution starting at resolver position = 0 and its width is approximately one quadrature encoder width. This output comes from an 26LS31 type RS-422 compatible line driver. Maximum recommended load current is ± 20 mA, which corresponds to a minimum line-to-line load resistance of 100Ω . This drive capacity corresponds to 10 RS-422 compatible inputs such as the SCE900 encoder inputs. This output is indefinitely short circuit (to I/O RTN) proof.

Encoder Inputs
 CH A IN,
 $\overline{\text{CH A IN}}$,
 CH B IN,
 $\overline{\text{CH B IN}}$, Step +,
 Step -, Dir +,
 Dir -, Step Up +,
 Step Up -, Step
 Dn +, Step Dn -
 J4-21, 22, 23, 24

These inputs are used as a quadrature encoder, step and direction, or up and down count format incremental signal source. The decoding mode is set by the EncMode parameter. The scale factor of this incremental position command input is fully adjustable with software parameters. Full decoding speed or more noise immune slow speed decoding is software selectable.

These two input pairs are differential and are detected by 26LS32 type RS-422 compatible line receivers. As differential inputs, the recommended common mode range is $< \pm 7 \text{ V}$ with respect to I/O RTN and the guaranteed differential voltage logic thresholds are $> \pm 0.2 \text{ V}$. Recommended drivers should be able to source and sink $> 3 \text{ mA}$ to and from these inputs. Each of these inputs have internal bias networks to allow easy connection to single ended sources. When an input is open circuited it biases itself to between 2.2 and 2.5 V. The remaining input pair terminal have a single ended guaranteed logic low for inputs $< 2.0 \text{ V}$ and a guaranteed logic high for inputs $> 2.7 \text{ V}$. These levels are compatible with a TTL driver combined with a pull up resistor. Pull up resistor should be $< 470 \Omega$.

+5 VDC, +5 VDC
 RTN Output
 J4-25, 18

These two connections provide an auxiliary power supply for the user. This output is 5 VDC $\pm 5\%$ and is I/O RTN short circuit protected. This supply goes to the option card and may also appear on an option card I/O connection point. For example, the +5 VDC on the OCE930 J31 connector. The maximum load limit for all connections to this supply is 200 mA.

5.4.7.6. J4 ENCODER I/O INTERFACE SCHEMATICS DIAGRAM

5.4.7.6.1. Encoder Inputs

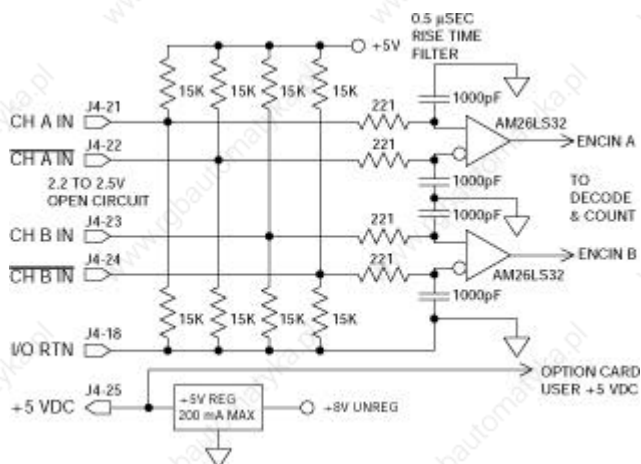

5.4.7.6.2. Emulated Encoder Outputs

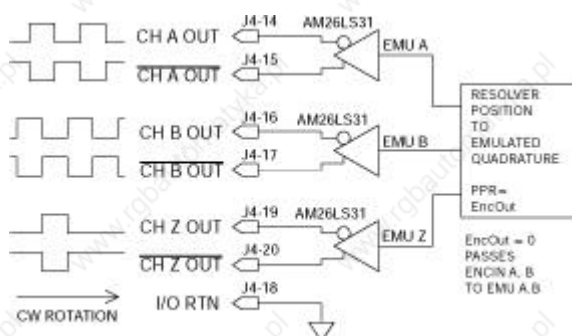

6. DIAGNOSTICS AND PROTECTION CIRCUITS

The drive is fully protected against “normal” abuse and has a 7 segment LED visible on the front panel to indicate drive status. The base servo drive has the following specific protections:

Output motor short circuit protection line-to-line and line-to-neutral.

Interface to Pacific Scientific’s standard motor PTC or a normally closed thermostat to sense motor over temperature.

Internal monitoring of the power stage heat sink temperature for drive over temperature.

Bus over voltage detection.

Bus under voltage fault with adjustable threshold.

Incorporating the measured heat sink temperature there is an excessive current I²t fault. This fault limits the peak current time and intelligently changes the continuous current fault trip dependent on the measured heat sink temperature to limit the continuous output current.

Control voltage under voltage detection.

The auxiliary +5V output is short circuit to I/O RTN protected.

All control outputs are short circuit to I/O RTN protected.

When a drive is powered up without valid Personality parameters the power stage cannot be enabled and no damage occurs to the drive.

If there is an Option Card plugged in at power up, then the drive will fault if the Option Card is unplugged while the power is still on.

The digital signal processor has a watchdog/throughput fault to help detect drive software errors.

6.1. Fault Sequence

The following sequence occurs when a fault is generated by the protection circuits. The fault source is latched, the output stage is disabled, the Fault mappable output function is activated, and the status display indicates the appropriate blinking fault code. Faults are cleared by activating the Fault Reset input or by cycling the 120/240 VAC Control Power.



6.2. Fault Codes

The following table lists the status display codes shown on the system status LED. In the basic product, the LED decimal point is not used. It is reserved for use with option card accessories. A quick blinking display implies a hard fault. If an entry is not specifically listed as blinking, the display is steady. If listed as just blinking, the display blinks quickly. If an entry shows multiple characters, the characters alternately flash between the two values with unequal blank display pauses between to help indicate the intended character order.

Status Code	Description
0	No faults, power stage disabled, control voltage OK.
8	No faults, power stage enabled, control voltage OK.
8r Alternating	No faults, power stage enabled, CcwInh active preventing CCW motion.
8r Alternating	No faults, power stage enabled, CwInh active preventing CW motion.
8r Alternating	No faults, power stage enabled, CwInh and CcwInh both active preventing motion.
7 Blinking	Velocity feedback (VelFB) over speed To further identify this fault see software variable ExtFault: ExtFault = 1 VelFB > 21038 RPM ExtFault = 2 VelFB > max(VelLmtxx)*1.5
2 Blinking	Motor over temperature
3 Blinking	Drive over temperature
4 Blinking	Drive I*t
5 Blinking	SC9x3: Line-neutral over current
6 Blinking	Control ±12 V under voltage
7 Blinking	Output over current or Bus over voltage
8 Blinking	Shunt regulator overload
8 Blinking	Bus over voltage detected by DSP
b Blinking	Auxiliary +5V low
c Blinking	Not assigned
d Blinking	Not assigned
*E	Processor throughput fault

Status Code	Description
*E Blinking	Control power AC line dip or power up self test failure
	To further identify this fault see software variable ExtFault:
	ExtFault = 1 Calibration data corrupted
	ExtFault = 2 Excessive DC offset in current feedback sensor
	ExtFault = 3 DSP incompletely reset by line power dip
	ExtFault = 6 Excessive DC offset in Analog Command A/D
	ExtFault = 7 Unable to determine option card type
	ExtFault = 8 DSP stack overflow
	ExtFault = 10 Software and control card ASIC incompatible
	ExtFault = 11 Actual Model not same as stored in NV memory
	ExtFault = 12 Unable to determine power stage
ExtFault = 15 RAM failure	
ExtFault = 16 Calibration RAM failure	
E1 Alternating	Bus under voltage, bus voltage VBusThresh*
E2 Alternating	Ambient temperature too low
E3 Alternating	Encoder commutation alignment failed (Only for CommSrc = 1)
E4 Alternating	Software and non-volatile memory versions not compatible
*E5 Alternating	Control card hardware not compatible with software version
E6 Alternating	Drive transitioned from unconfigured to configured while enabled
E7 Alternating	Two AInNull events too close together
F1 Alternating	Position following error fault
F3 Alternating	Parameter memory error
	To further identify this fault see software variable ExtFault:
	ExtFault = 13 Control card non-volatile parameters corrupt
	ExtFault = 14 Option card non-volatile parameters corrupt
UC Alternating	Unconfigured drive

*These fault states can not be reset with the Fault Reset function and require the line control power to be cycled.

Status Code	Possible Cause
1 Blinking	Loose or open circuit wiring to the resolver feedback connector J3. Actual motor speed exceeded $1.5 * (\text{Max Of } \text{VelLmtLo} \text{ or } \text{VelLmtHi}) \text{ or } 21,038 \text{ rpm}$ which is the over speed trip level.
	For Encoder velocity feedback (RemoteFB = 2) check that EncIn is set properly to correctly scale the VelFB units.
2 Blinking	Loose or open circuit wiring to motor PTC thermal sensor (J3-8 & J3-9). High ambient temperature at motor.
	Insufficient motor heat sinking from motor mounting.
	Operating above the motor's continuous current rating.
	Inoperative cooling fan.
3 Blinking	High drive ambient temperature. Restriction of cooling air due to insufficient space around unit.
	Operating above the drive's continuous current rating.
	Inoperative cooling fan.
	 See HSTemp, ItFilt, and ItF0 for information on measuring thermal margin in an application.
4 Blinking	Mechanically jammed motor. Motion profile accelerations too high.
	Machine load on the motor increased perhaps by a friction increase.
	Problem with wiring between drive and motor yielding improper motion.
	Drive and/or motor under sized for application.
	 See HSTemp, ItFilt, and ItF0 for information on measuring thermal margin in an application.
5 Blinking	Motor power wiring (J2-2, 3, or 4) short circuit line-to-ground (neutral).
	Motor power cable length is enough longer than the data sheet specification to cause excessive motor line to earth ground (neutral) capacitance.
6 Blinking	Insufficient control AC voltage on J1-5 to J1-6. External short on signal connector.
	Internal drive failure.

Status Code	Possible Cause
7 Blinking	<p>Motor power wiring (J2-2, 3, or 4) short circuit line-to-line or line-to-ground (neutral). Internal motor winding short circuit.</p> <p>Insufficient motor inductance causing output over current faults.</p> <p>KIP or KII improperly set causing excessive output current overshoots.</p> <p>Motor AC power input voltage too high.</p> <p>Disconnected regeneration resistor on J5.</p> <p>External regeneration resistor ohmage too large yielding Bus OverVoltage fault.</p>
8 Blinking	<p>Excessive regen in application.</p> <p>Improper external regen wiring or components on J5.</p>
A Blinking	Actual bus over voltages are usually, but not always, detected and displayed as a blinking 7 fault. See that entry for more information.
b Blinking	Short circuited wiring on the output (J4-25).
	Load exceeds the current rating of this supply.
E Solid	Drive hardware failure or drive software bug.
E Blinking	See the status variable ExtFault for further information about the exact failure.
E7 Alternating	Check the measured bus voltage (VBus) and the fault threshold (VBusThresh) to make sure they are consistent.
E2 Alternating	Ambient temperature is below drive specification. Drive's internal temperature sensor has a wiring problem.
E3 Alternating	Problems with encoder feedback wiring to J4 when CommSrc = 1. Load inertia more than 100 times the motor inertia leading to settling times long compared to the 2-second encoder commutation alignment. Artificially extend the alignment time by pulsing the hardware enable (J4-6).
E4 Alternating	OC930-001-01 (drive software upgrade card) was used to set up an old drive. Then either no or a standard OC930-001-00 (no software upgrade option card) is installed, resulting in the old software being used in the drive.

Status Code	Possible Cause
E5 Alternating	Attempt to upgrade the drive's software will not work. Contact factory for upgrade details.
	Resolver wiring error. Remove J2 and J3 connectors. Cycle AC power. If fault is now a 2, correct resolver excitation wiring.
E8 Alternating	Unconfigured drive (Status LED alternates U, C after power up) was fully configured with the drive motor power enable active. This fault can be reset or the control AC power cycled to get the drive-motor operating.
E7 Alternating	The AInNull function was re-activated too soon after going inactive. This can be caused by switch bounce on the input pin mapped to activate AInNull.
F1 Alternating	The motor is either stalled or partially jammed or the value for PosErrorMax is set too sensitive for the loop tuning and commanded motion profiles.
F3 Alternating	Glitch while last saving the NV parameters. Swapped option card has corrupted NV memory contents. Hardware problem with the NV memory. See ExtFault status variable to determine whether NV memory corruption is inside the drive or on the option card. Re-download parameters to restore drive operation.

6.3. Customer Support/Contact Information

Danaher Motion Pacific Scientific technical documentation is updated periodically and may be changed without notice. The latest documentation can be found on our website.

For information on this product or where to purchase near you, contact: your local distributor.

Danaher Motion Customer Support

Phone: (815) 226-2222

Fax: (815) 226-3080

Email: customer.service@danahermotion.com

Website: www.danahermotion.com

7. POWER UP/DOWN SEQUENCING

The IBM PC and compatibles user interface utility for the SCE900 with OCE930 Option Card runs under Microsoft Windows 3.1 or Windows95 and is called 930WIN.EXE.

7.1. MA930

The following procedures illustrate how to install and launch the utility with brief instructions. For complete information on this utility please see the *MA930 – OC930 Hardware and Software Reference Manual*.

7.2. Installing 930WIN.EXE

To install 930 Dialogue for Windows:

- 1 Insert the 930 Dialogue for Windows diskette in your disk drive (A: or B:).
- 2 Start Windows
- 3 Choose **Run** from the **File** Menu of Program Manager.
- 4 At the Command Line, type **A:\setup930** (or **B:\setup930**)
- 5 Press **<Enter>** or click on **<OK>**.

7.3. Starting 930WIN

To begin using 930 Dialogue for Windows, open the 930WIN Group in Program Manager, if not already open. Double click on the 930WIN icon to launch the program.

Once in the utility, go to the **Options** Menu and select **Port Configuration** to specify a serial port for communication. At this point, the software is fully installed, configured, and ready for use.

SCE900 drives are shipped from the factory in the unconfigured state. When first powered up, the drive flashes **UC** and will not run a motor. Drives are easily configured with the 930WIN.EXE utility.

7.4. Configuring a Drive

Go to the **Options** menu and select **Drive Set Up**.

At the next screen select the default Auto mode by hitting the return key. At this point, answer the questions as they come up. When this short process is complete, the drive is set up for the motor you keyed in and will drive the specified unloaded motor quite well and should allow you to experiment with 930.EXE's many other features.

For further information on this utility use the on line help and experiment with it. In the **Drive** menu, select **Variables** to experiment with individual drive parameters.

8. SCE902

The information contained in this section applies to the SCE902 ONLY. The SCE902 is designed for use within machines that require compliance with European Safety and EMC Directives.

The SCE900 is a family of economical, high performance medium power single axis servo drives meant to go with resolver equipped brushless 3-phase permanent magnet motors. Unlike the rest of the SCE900 family, the power electronics of the SCE902 are compatible with 115 to 240 VAC single- or 3-phase mains. A properly mounted external line filter must also be wired in series with the supply mains for the SCE902 to maintain CE compliance.

8.1. Features

All digital DSP-based control including the current loops.

All system and application parameters set in software

Digital auto-tuning for easy and predictable set-up

Advanced patented Digital Resolver to Digital (DRDC) converter with standard 5.3 arc minute absolute accuracy and 24 bit position resolution. U.S. patent number 5,162,798.

Advanced Signature Series sinusoidal current control for low shaft torque ripple and uniform control dynamics at all shaft speeds.

Modular construction with a user removable option card allowing easy configuration.

- RS-232/485 serial interface
- SERCOS fiber optic multi-axis interface
- Single axis programmable positioning
- Removable Personality parameters
- Field upgrade of drive software

Analog, incremental digital, serial, or optionally SERCOS digital fiber optic or programmable command sources for shaft torque, velocity, or position control.

16 different emulated quadrature encoder output resolutions up to 16,384 PPR.

CE marked

8.2. Standard Features

In addition to the above distinctive features the SCE900 family's many industry standard features include:

Integral power supply with totally enclosed panel mount packaging.

Single resolver motor feedback survives hostile environments.

Extensive protection circuits and diagnostics to ease set-up.

IGBT power stage with inaudible high frequency PWM.

8.3. Option Cards

Option cards extend the base SCE900 functionality and allow the operating adjustments and parameters to be set. These "personality" adjustments or parameters can be stored in the base SCE900's non-volatile EEPROM memory or in the option card's non-volatile EEPROM memory. If the personality is stored in the base SCE900, the option card can be removed after setting the parameters and a blank panel substituted to lower the installed cost or to prevent un-authorized changing of drive personality in the field. Available option cards include:

OCE900-001	Blank panel to cover option slot
OCE930-001-00	Serial communications option card RS-232 or RS-485 to set parameters
OCE940-001-01	SERCOS interface option card industry standard LAN fiber optic interface for command and to set parameters
OCE950-50x-01	Standard single-axis programmable positioning option card
OCE950-60x-01	Enhanced single-axis programmable positioning option card

8.4. SCE902 Accessories

8.4.1. Plug-in Cards

OCE900-001	Blank option panel to cover an unused option card slot.
OCE930-001-0x	Serial communication option card to provide RS-232 or RS-485 communications for setup or for command. Suffix -00 is standard, -01 includes base servo drive software upgrade. This option card also allows removable personality functionality. Includes 3 ½" floppy disc for 930 Dialogue, the PC communications software.
OCE940-001-01	SERCOS interface option card to provide command and setup over the industry standard SERCOS fiber optic ring.
OCE950-50x-01	Standard Programmable Positioning option card to provide programmable single axis motion control.
OCE950-60x-01	Enhanced Programmable Positioning option card to provide programmable single axis motion control. The Enhanced version of the OC950 supports additional features, including MODBus, Allen-Bradley DF-1 communications, and camming functionality.

8.4.2. Connector Mate Kits

CAE902	Screw terminal and d-subminiature mates for the SCE90x servo drive.
CAE902-TB	Screw terminal and d-subminiature terminal block adapter mates for the SCE90x servo drive.

8.4.3. Manual and Documentation Kits

MAE900	<i>SCE900 Family Hardware Reference Manual</i> for the SCE900 series base servo drives.
MA930	<i>OC930 Hardware and Software Reference Manual</i> for the OC930 serial communications/setup option card.
MA940	<i>OC940 Hardware and Software Reference Manual</i> for the OC940 SERCOS interface option card.
MA950-IDE	<i>OC950 Installation and Hardware Reference Manual</i> and <i>950BASIC Reference Manual</i> for the OC950 single-axis programmable positioning option card. Includes 3 ½" PC floppy for 950IDE Integrated Development Environment.

8.5. Electrical Specifications

8.5.1. Output Power

	SCE9x2
Peak Output Current (0-p)	
5 seconds, up to full 50°C (A)	7.5
Continuous Output Current (0-p)	
25°C Convection Cooling (A)	3.75
50°C Forced Air Cooling (A)	3.75
50°C Convection Cooling (A)	2.5
Peak Output Power at 240 VAC*	
1 second, up to full 50°C (kW)	2.2
Continuous Output Power	
At 240 VAC three phase	
25°C Convection Cooling (kW)	1.1
50°C Forced Air Cooling (kW)	1.1
50°C Convection Cooling (kW)	0.75
At 240 VAC single phase*	
25°C Convection Cooling (kW)	0.80
50°C Forced Air Cooling (kW)	0.80
50°C Convection Cooling (kW)	0.55
Power Stage Efficiency at P_{cont} (%)	95
Shunt Regulator Power	
Peak Power (300 ms) (kW)	3.0
Continuous Power	
25°C Convection Cooling (W)	20
50°C Forced Air Cooling (W)	25
50°C Convection Cooling (W)	20
Maximum External Regen Duty Cycle (%)	16
Bus Capacitance Energy Absorption	
From 320 V Nominal Bus (joules)	15
Output Current Ripple Freq f_s (kHz)	20
Minimum Motor Inductance l-l (mH)	4.0
Maximum Motor Inductance l-l (H)	4
Maximum Motor Power Cable Length	50 m/164ft
Conformance	EMC Directive 89/336/EE

*For standard 120 VAC single-phase operation derate the Peak and Continuous Output Power ratings by 50%. Consult factory for 120 VAC bus voltage doubled customization specifications.

8.5.2. Input Power

The drive is capable of direct line operation. All units are fully isolated and do not require external isolation transformers. Also, the inrush current on the connection to the line is internally limited to a safe level for the drive. There are no voltage selection or ranging switches required to operate within the specified voltage input ranges. It is the responsibility of the user to supply appropriate fuses or circuit breakers in the J1 AC Power motor power lines to comply with local electrical codes.

The control input power required depends on the option card plugged in and the load on user +5 VDC. It should be between 15 and 30 watts. The AC input motor power depends on output power and the losses in the power stage. The control power input has a single UL/CSA rated fuse in line with one of the AC line inputs.

SCE900 Control Power Supply	
Input Voltage Range	90 to 264 VAC 47 - 440 Hz single-phase or 130 to 370 VDC
Ride Through Time For AC Line Drop	90 VAC 50 Hz >1 50 Hz cycle 120 VAC 60 Hz >2.5 60 Hz cycles 240 VAC 60 Hz >10 60 Hz cycles

SCE900 Motor AC Power Supply				
Model Number	Voltage Range (VAC)	Phases	Suggested Transformer (kVA)	Maximum AC Line* (kVA)
SCE9x2	90-264	1 or 3	2 to 3	100

*Maximum AC Line is specified to limit the line surges coupled to the drive.

Bus Voltage (nominal, standard drive)	
240 VAC Three-Phase Input	320 VDC
120 VAC Single-Phase Input	155 VDC

SCE900 Inrush Current & Fusing				
Model Number	Inrush Peak Current	Inrush Pulse Width	Fuse Type	Manufacturer Part Number
SCE9x2	140 A 0-p	3 ms	15 A 250 V TimeDelay	Bussmann MDA-15

8.6. Performance Characteristics



Unless otherwise specified, the below specifications are worse case limits and apply over the specified operating ambient temperature and over the specified operating line voltage.

8.6.1. Motor Current Control

Motor Phase Current Waveform	Back EMF Matched Pseudo Sine
Motor Shaft Torque (Ignoring motor magnetic saturation)	
Peak	$(Kt0-p)^* \frac{\sqrt{3}}{2} * (\text{Drive } I_{\text{Peak}} 0-p)$
Instantaneous	$(Kt0-p)^* \frac{\sqrt{3}}{2} * \text{IFB}$
Bandwidth	
Maximum Bandwidth (kHz)	1.5
Recommended Bandwidth (kHz)	1.0
Bandwidth Variation For Fixed Motor L (%)	± 10
Bandwidth Variation For $\pm 25\%$	
AC Line Variation (%)	± 2
Update Period (μs)	62.5
Recommended Motor Electrical Frequency (Hz)	< 400

8.6.2. Analog Command

Maximum Differential Range (volts)	± 13.5
Maximum Single Ended Range (volts)	± 21
Full Scale Tolerance (%)	± 5 (worse case) ± 1 (typical)
Linearity (% Full Scale)	0.1
Monotonic to	$< 2^{-16}$ Full Scale
S/N Ratio Referred to Full Scale	
Full A/D Bandwidth (bits)	14
150 Hz A/D Bandwidth (bits)	16
10 Hz A/D Bandwidth (bits)	18
Offset	Adjustable to 0
Maximum Unadjusted Offset (mV)	50
Offset Drift ($\mu\text{V}/^\circ\text{C}$)	250 (typical)
CMRR (dB at 60 Hz)	> 30

8.6.3. Digital Position Commands

Modes	Quadrature Encoder, Step & Direction, or Up & Dn Count
Maximum Input Rate For Fast Decode	
Quadrature Decode Max Line Frequency (kHz)	800
Step/Dir Decode Max Step Frequency (kHz)	800
Up/Dn Count Max Frequency (kHz)	800
Minimum Fast Decode Pulse Width (μ s)	0.6
Fast Decode Direction Setup Time (μ s)	0.6
Fast Decode Direction Hold Time (μ s)	0.6
Relative Timing For Filtered Decode	4, 8, or 16 to 1 e.g., Max Step Frequency 800, 200, 100, or 50 kHz

8.6.4. Velocity Loop

Maximum Stable Bandwidth (Hz)	> 400
Update Period (μ s)	250
Range (rpm)	0 to 21,000
Command Resolution (rpm)	< 0.001
Velocity Loop Compensation Parameters	
KVP Range (Depends on I_{peak})	0 to 12.6 (I_{peak})(1/rad/sec)
KVP Resolution (bit)	16
KVI Range (Hz)	0 to > 200
KVI Resolution (bit)	16
ARF0* Range (Hz)	0.01 to > 1e5
ARF1* Range (Hz)	0.01 to > 1e5
ARZ0* Range (Hz)	0 to > 1e5 or off
ARZ1* Range (Hz)	20 to > 1e5 or off
CMDGAIN Range (rpm/V)	0 to $\pm 15,000$
	0 to $\pm 10(I_{peak}) V^{-1}$
CMDGAIN Resolution (bit mantissa)	³ 16

*ARx0 set to a negative number allows complex poles/zeros. In this case, ARx1 becomes the Q and the corresponding $|ARx0|$ is the frequency in Hz.

8.6.5. Position Loop

Maximum Stable Bandwidth (Hz)	> 100
Update Period (ms)	1
Position Range (rev)	0 to ± 32768
Position Error Range (rev)	0 to ± 4500
Command Resolution	2-16 Rev = 0.33 arc min
Position Loop Compensation Parameters	
KPP Range (Hz)	0 to > 150
KPP Resolution (bit)	16
KVFF Range (%)	0 to 199.9
KVFF Resolution (bit)	16

8.6.6. General

Max Delay AC Line To Control Supply On (second)	0.75
Max Delay AC Line To Fully Operational (second)	2.0

Fully operational by "A" of
"PACSCI" LED status message

8.6.7. Environmental

Operating Ambient Temperature Convection Cooling:	
Full Ipeak /2 continuous rating (°C)	0 to 25
Linearly derate Ipeak /2 continuous rating per (1 - (T - 25°C)/75°C) (units are °C)	25 to 60
Operating Ambient Temperature Forced Air Cooling:	
Full Ipeak /2 continuous rating (units are °C)	0 to 50
Linearly derate Ipeak /2 continuous rating per (1 - (T - 50°C)/30°C) (units are °C)	50 to 60
Storage Temperature (units are °C)	-40 to 70
Humidity, non-condensing (%)	10 to 90
Altitude	1600 m (5280 feet)

8.6.8. Mechanical

The SCE900 packaging is totally enclosed single axis panel mount.

8.6.9. Size

Model	Height	Width	Depth
SCE9x2	370 mm/14.5"	60 mm/2.35"	218 mm/8.6"

8.6.10. Weight

Model	Weight
SCE9x2	3.2 kg/7 lb.

8.7. Resolver Feedback Specifications



Unless otherwise specified, the below specifications are worse case limits and apply over the specified operating ambient temperature and over the specified operating line voltage.

8.7.1. Resolver Position Signal

Resolution/Rev	24 bits = 0.0013 arc min
Repeatability	$< \pm 2^{-18}$ Rev = ± 0.08 arc min RMS
Noise	
No Filtering	$< 2^{-16}$ Rev RMS = 0.3 arc min RMS
150 Hz Single Pole Filtered	$< 2^{-17}$ Rev RMS = 0.16 arc min RMS
10 Hz Single Pole Filtered	$< 2^{-19}$ Rev RMS = 0.04 arc min RMS
DC Offset Temperature Drift	$< 2^{-18}$ Rev/ $^{\circ}$ C = 0.08 arc min/ $^{\circ}$ C
Absolute Accuracy	
Drive only	$\pm 2^{-12}$ Rev = ± 5.3 arc min
Drive with 20 arc min resolver	$\pm 2^{-9.75}$ Rev = ± 25 arc min
Software Update Time	1 ms

8.7.2. Resolver Velocity Signal

Resolution (rpm)	< 0.001
Quanta (rpm)	< 0.0143
Noise	
No Filtering (rpm RMS)	< 3
150 Hz Single-Pole Filtered (rpm RMS)	< 0.6
10 Hz Single-Pole Filtered (rpm RMS)	< 0.06
DC Accuracy	
Typical at 25 $^{\circ}$ C (%)	± 0.01
Worse case (%)	± 0.05
Ripple	
Drive only (% p-p at 1000 rpm)	0.75
Drive with 20 arc min resolver (% p-p at 1000 rpm)	3
Offset (rpm)	< 0.0001
Software Update Time (μ s)	250

8.7.3. Emulated Encoder Output Signals

Available Resolutions (PPR)	
Binary	128, 256, 512, 1024, 2048, 4096, 8192, 16384
Decimal	125, 250, 500, 1000, 2000, 4000, 8000, 16000
Maximum Output Line Frequency (kHz)	833
Max Recommended Speed at 16384 PPR (rpm)	2900
Max Recommended Speed at 4096 PPR (rpm)	11600
Marker Pulse Width	~ 1 Quadrature Pulse

8.7.4. General

-3 dB Bandwidth (Hz)	> 1500
-45° Phase Lag (Hz)	> 400
Resolver Excitation Frequency (Hz)	6510.42
Max Tracking Rate (rpm)	> 48600
Max Recommended Rate (krpm)	25
Max Tracking Acceleration (rpm/s)	> 16×10^6
Maximum Feedback Cable Length	50 m/164 ft

8.8. Use Conforming with Requirements

The equipment described herein has been developed, produced, tested and documented in accordance with the corresponding standards. During use conforming with requirements, the equipment is not dangerous for people or equipment. Use conforming with requirements means that the safety recommendations and warnings detailed in this manual are complied with and that the applicable regulations for safety (machine directives, etc.) and noise suppression (EMC Directives) are observed while operating the drive.

At the end of its lifetime, dispose of or recycle the drive according to the regulations applicable at that time.

8.9. CE-Approval

The CE initials confirm that the SCE902 drive satisfies all requirements of CE Directives.

The equipment is not ready to operate without additional installations (cable, motor, filter, etc.). Thus, all necessary tests and measurements had to be made on a typical installation. The test installation with all peripheral devices, as well as the test results and measurements are recorded in detail in documentation that is available from the manufacturer on request. The test installation, to which the Declaration of Conformity refers to, is noted on page 8-13.



If the connection method on your machine is different from the one described on page 8-16, or in the event of use of components other than those that we have specified, adherence to interference limit values cannot be guaranteed.

8.9.1. Declaration of Conformity

In our Declaration of Conformity, we affirm our compliance with Directive 73/23/EEC (Low voltage Directive) and with Directive 89/336/EEC (EMC Directive).

For the SCE9x2, EMC testing was done according to EN61800-3 (Emission limits according to chapter 6.3.1 of that regulation, First environment / restricted distribution).

During assembly of our product in a machine, startup (that is, normal operation) is prohibited until the end-product complies with Directive 89/392/EEC (Machine Directive) and directive 89/336/EEC (EMC Directive).

The machine manufacturer must prove that the complete system conforms with all relevant European Directives.

Drive conformance to specified standards is certified by the Declaration of Conformity on the following page.

CE Declaration of Conformity

This is to certify that:

Pacific Scientific
110 Fordham Road
Wilmington, MA 01887 USA

Declares that the product(s):

Designation *DIGITAL SERVO DRIVE*

Type *SCE902*

comply with the following relevant regulations:

CE Guideline *72/23/EEC* *Low Voltage Directive*

Applied harmonized standards: EN 50178: 1997

CE Guideline *89/336/EEC* *EMC Directive*

Applied harmonized standards: EN 61800-3: 1995

Manufacturer's Contact: Peter Deneault
Compliance Engineer

Issued By: Pacific Scientific
President, William T. Fejes

Place, Date: Wilmington, MA, USA, 08-11-98

Legally binding
Signature



8.10. Installation

8.10.1. Installation and Commissioning

8.10.1.1. INSTALLATION

Installation and wiring of the drive must be completed only by qualified personnel having a basic knowledge of electronics, installation of electronic and mechanical components, and all applicable wiring regulations.

8.10.1.2. COMMISSIONING

Commissioning of the machine utilizing the drives must be done only by qualified personnel having broad knowledge of electronics and motion control technology.

8.10.2. Safety Requirements

As the user or person applying this unit, you are responsible for determining the suitability of this product for the application. In no event will Pacific Scientific Company be responsible or liable for indirect or consequential damage resulting from the misuse of this product.

Read this manual completely to effectively and safely operate the SCE900 series unit.

8.10.3. European Directives

Comply with the applicable European standards and Directives. In Germany these include:

DIN VDE 0100 (instructions for setting up power installations with rated voltages below 1000 V).

DIN - EN 60 204 - Part 1, (VDE 0113, part 1) instructions relative to electric equipment in machines for industrial use.

prDIN EN 50178, (VDE 0160) equipping high-voltage current installations with electronic operating means.

8.10.3.1. SAFETY

The following requirements must be met to ensure compliance with the Low Voltage Directive:

Never connect or disconnect any drive connectors or terminals while the power is switched on.

The climatic conditions shall be in accordance with EN 50178 climatic class: Type B, temperature and relative humidity: Class 3K3.

This drive is to be installed inside a motor/control cabinet accessible by qualified personnel only.

Electronic drives contain electrostatic sensitive devices which can be damaged when handled improperly. Qualified personnel must follow ESD protection measures. For example: wear grounded heel and wrist straps when contacting drive.

The discharge time for the bus capacitors may be as long as 5 minutes. After disconnecting the drive from the ac mains be sure to wait 5 minutes before removing the drive's cover and exposing live parts.

Follow IEC 536-2 and IEC 1140 for installation protection against electric shock.

Installation shall be performed in accordance with local electric codes, local accident prevention rules, EN 50178 and EN 61800-3.

Due to high leakage current this drive is to be permanently installed, i.e. hard wired. The PE connection shall be made by two separate conductors between the earth ground and the two PE terminals on the device.

Consult the factory before using this product on a circuit protected by a residual-current-operated protective device (RCD).

External, supply line, fusing is required. Use 15 A 250 V Time Delay fuses such as Bussman MDA-15.

Motor cable shield must be connected to protective earth.

All covers shall be closed during operation.

During periods of extreme regeneration or excessively high input voltage the temperature of the housing may exceed 70 °C in the area of the regen resistor, upper rear of housing.

When using an external regen resistor, regen resistor cable should be rated at 450 VDC and shielded with shield connected to PE.

8.11. Installing the SCE900 Servo Drive

Much of the connection information presented in this section is summarized in the figure on the following page.

8.11.1. Mounting the Drive

The SCE900 drives are designed for operation in a cabinet. Follow these installation instructions:

Mount the drives vertically inside a cabinet on a flat, solid, electrically conductive, mounting surface which is connected to PE (protective earth ground) and is capable of supporting the weight of the unit.

Remove the paint on the back of the drive as well as on the mounting surface over an area extending at least 12 mm (0.5") from the mounting bolts to achieve good electrical connection over a large area between the drive and grounded mounting surface.

Install conductive clamps near the drive on the mounting panel (ground plane) for electrically connecting the outer shield of certain cables (defined below) to the panel. Remove about 10mm (0.5") of the outer jacket of these cables where the clamp will be to expose the braided shield before inserting under the clamp and tightening. The length of the cable between the drive connection and the clamp should be as short as possible not exceeding 0.6 meters (two feet). If a ground plane is available at the other end of these cables, use a conductive clamp at that end to connect the shield to that ground plane as well.

Provide a minimum unobstructed space of 100 mm (4") above and below the drive. With convection cooling, provide 40mm (1.6") free space on either side of each unit. With forced air cooling, no free space is required on either side of each unit.

Insure the environment within the cabinet meets the requirements defined on page 8-8.

8.11.2. 9x2 CE Block Diagram

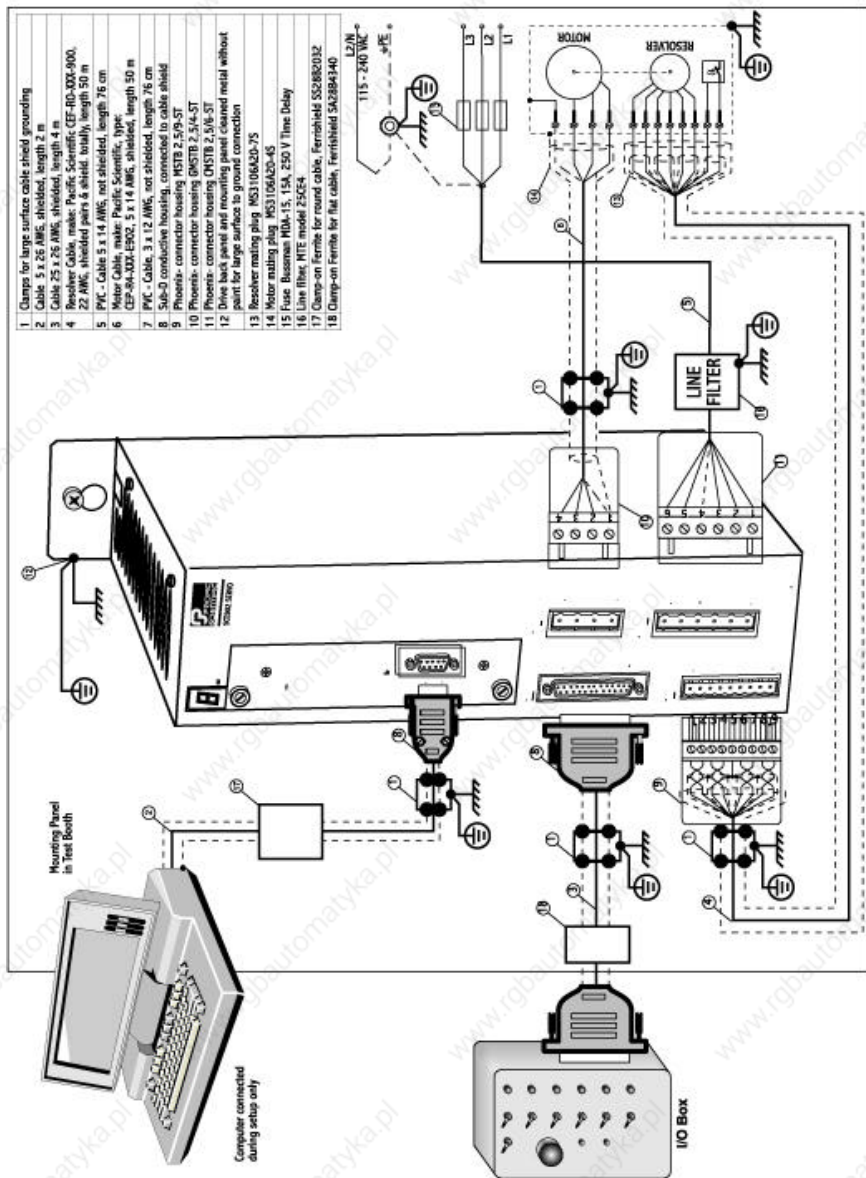

8.11.3. Mounting Guidelines

The figure below gives the key dimensions for use in physically mounting the product.

When mounting multiple drives in a row some customers have found the stiffness of the drive and their mounting panel to be too low. To increase the mounted mechanical integrity, connect to the threaded insert on the top front edge.

The overall drive panel dimensions and the mounted depth not including mating connectors is listed in the below chart. The extra depth for mating connectors is 1.0" or less.

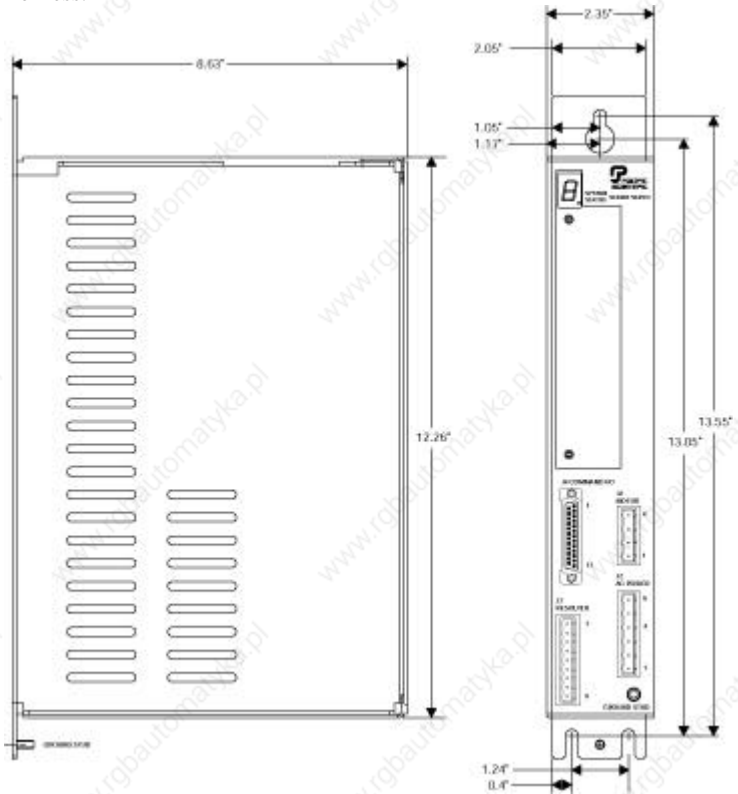

8.11.4. Grounding

8.11.4.1. CONNECTION TO PE GROUND

Because the leakage current to protective ground through the drive's internal line filter is approximately 15mA the following measures must be taken to comply with the European Low Voltage Directive EN50178:

J1 pin 4 must be connected to Protective Earth ground. The connection at the Protective Earth ground end must be hard wired (not utilize pluggable connections)

A ground fault detector (RCD) can NOT be depended upon for safety.

8.11.4.2. GROUNDING SHIELDS FOR SAFETY & LOW EMISSIONS/SUSCEPTIBILITY

Dangerous voltages, resulting from cable capacitance, exists on some cable shields if the shields are not connected to PE ground. Proper grounding of shields is also required to reduce radiated and conducted emissions as well as to protect against susceptibility to external and self generated noise. Follow these shielding requirements carefully:

The drive end of the motor cable shield must be connected to the PE pin on the J2 connector. The shield must also be clamped to the ground plane as described above. If cable with a separate inner foil shield and outer braided shield is used (Danaher Motion Pacific Scientific CE cables for example), connect the foil shield to the PE pin on the J2 connector and clamp the outer braided shield to the ground plane. If the leads for a motor holding brake are run with the motor leads, the holding brake leads must be separately shielded and the shield connected to the PE pin on the J2 connector.

The resolver cable should have inner shields around each twisted pair as well as an overall outer braided shield. The inner shields should be connected to J3 pin 5 while the outer shield should be clamped to the ground plane.

The control leads to the J4 connector should have an outer braided shield with the shield clamped to the ground plane.

If an external regen resistor is used, the leads between the drive and resistor must be shielded with the shield clamped to the ground plane.

8.11.4.3. GROUNDING THE MOTOR CASE

Insure that the motor's case is connected to PE ground. This is accomplished by the fourth wire in the motor cable connecting J2 pin 1 to the motor case.

If the motor is not properly grounded, dangerous voltages can be present on the motor case due to capacitive coupling between the motor windings and case.

8.11.5. Requirements for Safe Operation of the Drive

It is the machine builder's responsibility to insure that the complete machine complies with the Machine Directive (EN60204). The following requirements relate directly to the servo controller:

8.11.5.1. EMERGENCY STOP

If personal injury can result from motor motion, the user must provide an external hardwired emergency stop circuit outside the drive. This circuit must simultaneously remove power from the drive's motor power connector J1 and disable the drive (by disconnecting J4 pin 6 from I/O RTN).



The motor will coast under this condition with no braking torque.

If braking torque is required to quickly stop the motor, a dynamic brake can be added that loads the motor's windings resistively. The motor should not be loaded until the servo drive is disabled.



The holding brak, optional on Danaher Motion Pacific Scientific motors, is not intended to stop a spinning motor. It is designed to prevent a stopped motor from rotating due to an applied torque.

8.11.5.2. AVOIDING UNEXPECTED MOTION

Always remove power from J1 before working on the machine or working anywhere where injury can occur due to machine motion.

8.11.5.3. AVOIDING ELECTRICAL SHOCK

Never power the servo drive with the cover removed or with anything attached to circuitry inside the cover.

If the drive must be removed from the cabinet, wait at least five minutes after turning off power before removing any cables from the drive or removing the drive from the mounting panel.

Never plug or unplug any connectors to the drive while power is applied. Always power down and wait five minutes before connecting or disconnecting any wires to the terminals.

8.11.5.4. AVOIDING BURNS

The temperature of the drive's housing as well as an external regen resistor can exceed 70°C. There is a danger of severe burns if these regions are touched.

8.12. Preventing Damage to the Drive

Follow these guidelines to prevent damage to the servo drive during operation:

Never plug or unplug connectors with power applied.

Never connect or disconnect any wires to terminals with power applied.

Never plug or unplug an option card with control power applied.

If the drive is powered up and then powered down, wait at least five minutes from the previous power-up before re-applying power. This allows time for the surge limiting circuitry to recover which avoids high inrush currents.

If the drive indicates a fault condition, find the cause of the fault and fix it prior to resetting the fault or power-cycling the drive.

8.13. EMC

The following requirements must be met to ensure compliance with the EMC Directives:



Not intended to be used on a low-voltage public network which supplies domestic premises. May cause radio-frequency interference.

8.13.1. Line filter

To meet the conducted EMC requirements an external line filter is necessary. It is the responsibility of the customer to choose appropriate filtering for their application, Danaher Motion Customer Support is willing to assist in this choice. The CE test setup included a 25CE4 line filter manufactured by MTE. CE testing was performed using 50 m motor and resolver cables, the maximum lengths specified, to prove worst case conducted emissions compliance. The line filter should be mounted as close as possible to the drive. To provide maximum high frequency filtering remove any paint from between the filter, the drive and the conductive surface, ground plane they are bonded to.

8.13.2. MTE Corporation

1-800-455-4MTE or 414-253-8200

<http://www.mtecorp.com>

8.13.3. Shielding & Grounding

To meet radiated EMC requirements the serial, command I/O, motor and resolver cables should be shielded and grounded at the drive end. To guarantee maximum high frequency radiated noise reduction, the shields should have 360 degree termination to ground. Clamp the exposed portion of the shields to the front of the drive with the clamp supplied to terminate. The serial and command I/O cables can be terminated to ground through the D-sub connector if it provides 360 degree shield termination. It may also be necessary to add ferrites to the Command I/O and serial cables. Once again it is important to remove the paint from any grounding surfaces.

To avoid the risk of crosstalk, the motor and resolver cables should be kept away from sensitive signal cables such as telephone and intercommunication lines.

8.14. I/O Terminations

All terminations on the SCE902 drive are two piece pluggable connections. Also, all connectors are unique or keyed such that a cable can not be plugged into the wrong location or plugged in backwards.

In the list below an overbar on a signal name means that the signal is active low logic. For example, “Enable” enables the drive when this input is pulled low and disables the drive when it is high.

8.14.1. Earth Ground

Chassis Grounding Studs, M5-12 and M4-12, with nut and lock washer.

8.14.2. SCE902 Power Board Connectors

8.14.2.1. J1

AC POWER SCE9x2 7.5 mm Pluggable TB	
Pin	Description
1	240 VAC / 120 VAC (Input)
2	240 VAC / 120 VAC (Input)
3	240 VAC (Input)
4	CHASSIS GROUND
5	240 VAC / 120 VAC CONTROL POWER (Input)
6	240 VAC / 120 VAC CONTROL POWER (Input)

8.14.2.2. J2

MOTOR POWER SCE9x2 7.5 mm Pluggable TB	
Pin	Description
1	MOTOR CASE GROUND
2	MOTOR PHASE T (Output)
3	MOTOR PHASE S (Output)
4	MOTOR PHASE R (Output)

8.14.2.3. J5

REGENERATION INTERFACE SCE9x2 5 mm Fixed TB	
Pin	Description
1	REGEN RESISTOR (Output)
2	+ BUS (Output)
3	- BUS (Output)

8.14.3. SCE902 Base Servo Drive User I/O Connections

8.14.3.1. J3

FEEDBACK 5.0 mm Pluggable TB	
Pin	Description
1	RESOLVER S1 SIN + (Input)
2	RESOLVER S3 SIN - (Input)
3	RESOLVER S2 COS + (Input)
4	RESOLVER S4 COS - (Input)
5	SHIELD (I/O RTN)
6	RESOLVER R1 EXCITATION (Output)
7	RESOLVER R2 EXCITATION RTN (Output)
8	MOTOR PTC (Input)
9	MOTOR PTC RTN (Input)

8.14.3.2. J4

COMMAND I/O 25 Position D subminiature male Default functions for BDIOs are listed in ().			
Pin	Description	Pin	Description
1	ANALOG CMD + (Input)	14	CH A OUT
2	ANALOG CMD - (Input)	15	$\overline{\text{CH A OUT}}$
3	DAC MONITOR 1 (Output)	16	CH B OUT
4	DAC MONITOR 2 (Output)	17	$\overline{\text{CH B OUT}}$
5	I/O RTN	18	I/O RTN/+5 VDC RTN
6	ENABLE (Input)	19	CH Z OUT (Output)
7	BDIO 1($\overline{\text{Fault Reset}}$) (Bi-directional)	20	$\overline{\text{CH Z OUT}}$ (Output)
8	BDIO 2($\overline{\text{CwInh}}$) (Bi-directional)	21	CH A IN (STEP +) (STEP UP +) (Input)
9	BDIO 3($\overline{\text{CcwInh}}$) (Bi-directional)	22	$\overline{\text{CH A IN}}$ (STEP -) (STEP UP -) (Input)
10	BDIO 4(Mapped Off) (Bi-directional)	23	CH B IN(DIR +) (STEP DOWN +) (Input)
11	BDIO 5(Brake) (Bi-directional)	24	$\overline{\text{CH B IN}}$ (DIR -) (STEP DOWN -) (Input)
12	BDIO 6(Fault) (Bi-directional)	25	+5 VDC (200 mA max) (Output)
13	I/O RTN	(26)	I/O RTN on optional TB adapter mate

8.15. Drive Wiring Diagram

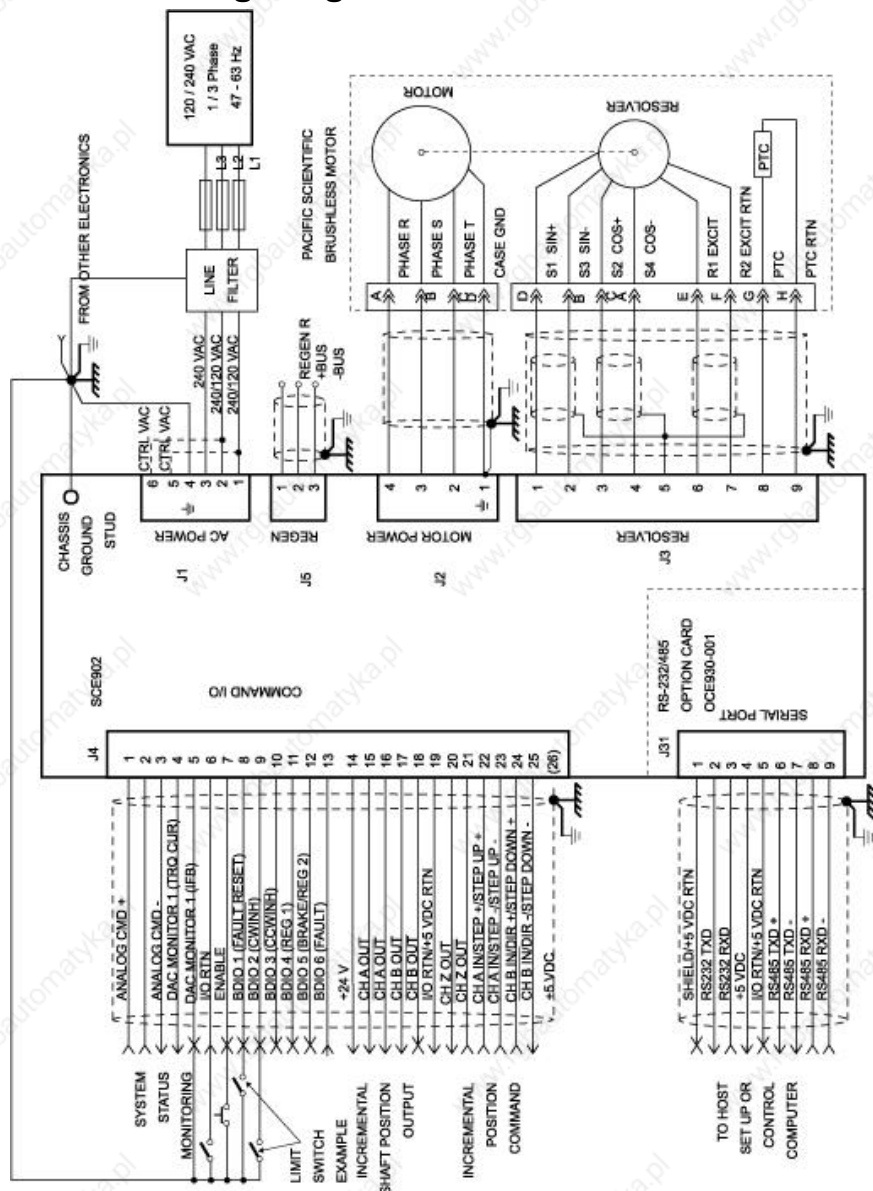

8.16. I/O Definitions

8.16.1. Earth Ground

Chassis Ground Stud This input provides a point for the user to connect the drive to earth ground for safety.

8.16.2. J1 AC Power

240/120 VAC These terminals connect the 240/120 VAC power provided by the user to the drive's power output stage bus to drive the motor.

240/120 VAC
Control Power These terminals connect the 240/120 VAC power provided by the user to the drive's control voltage power supply.

Chassis Ground Convenience connector point for the user to connect the drive to earth ground. Directly connected to the chassis and thus to the Chassis Ground Stud.



Local electrical code may require using the Earth Ground Chassis stud for this function.

8.16.2.1. FUSING

Use time-delay fuse in series with J1 pins 1, 2, and 3 as shown in the figure on page 8-16.

Model	Fuse
SCE9x2	15 A, 250 V, time-delay, Bussman, MDA-15

8.16.3. J2 Motor Power

Motor Phase R, S, T	These three terminations provide the 3-phase power output to the brushless motor.
Motor Case Ground	This termination provides a convenient point for the motor ground connection and motor power wire shield. Local electrical code may require using the Earth Ground Chassis stud for this function.

8.16.4. J5 Regeneration Interface

Regen These terminals connect the internal shunt regulator
 Resistor, - resistor or provide the connection points for an external
 Bus, + Bus resistor or external capacitor bank to absorb regenerated
 energy from the motor.

Model #	Resistance
SCE9x2	50 Ω

8.16.4.1. INTERNAL RESISTORS

The table below lists values for internal resistors.

Model	Resistance	Pacific Scientific #
SCE9x2	50 Ω , 55 W Ohmite F55J50R	350-150000-00

8.16.5. J3 Resolver

Resolver S1,
S2, S3, S4
Inputs These connections provide the inputs for the resolver's
 sine/cosine outputs. Differential inputs with > 75 V μ s
 common mode impulse range and > 25 k Ω input impedance.

Resolver R1
Excitation, R2 These connections provide the resolver excitation output. 9.2
Excitation RTN V RMS at 6510.42 Hz 75 mA RMS maximum load. These
Outputs outputs are fully short-circuit protected to I/O COMMON or
 to each other at room temperature (25°C), but at ambient
 temperatures above 50°C shorts longer than 5 minutes may
 cause damage.

Motor PTC,
PTC RTN These two inputs are intended to connect to a positive
Inputs temperature coefficient thermistor or normally closed
 thermostatic switch imbedded in the motor windings. When
 the resistance between these terminals becomes greater than
 6.2 k Ω the drive will fault and indicate a Motor Over
 Temperature fault. This circuit directly interfaces with
 Danaher Motion Pacific Scientific's standard motor PTC.



PTC RTN is connected to I/O RTN.

8.16.6. J4 Command I/O

Analog CMD
(+), (-) Inputs
J4-1, 2

These inputs accept the analog command from the user. This is a differential input to an A/D. It has a maximum single ended input range with respect to I/O RTN on either input of $\pm 21\text{V}$ and an input impedance of $> 50\text{k}\Omega$. The full scale differential command input range is $\pm 13.5\text{V}$. The offset and single pole low pass bandwidth of this signal is adjustable via a software setup parameter. When used as a motion command the gain from this input is also adjustable via a software setup parameter.

DAC Monitor 1, 2
Outputs J4-3, 4

These analog outputs are general purpose monitor points. The output range is $\pm 5\text{V}$ with a resolution of $10\text{V}/256 = 0.039\text{V}$. The source impedance is $1\text{k}\Omega$, which yields a maximum short circuit to I/O RTN current of $\pm 5\text{mA}$. These outputs are updated at the VELOCITY LOOP update rate. There is a 10kHz analog LPF on these outputs.

Each DAC MONITOR can be mapped by software to be one of a number of internal variables. The scale factor and the frequency of a single low pass filter pole are software adjustable on each output by the DM1Gain, DM1F0 and DM2Gain, DM2F0 software parameters for DAC Monitor 1 and 2 respectively. Variables marked with a "*" are not range clamped and are allowed to wrap around when the signal exceeds the output dac's voltage range. The other variables will clamp at maximum when they exceed the analog voltage range. The DAC Monitor List Table lists the defined signal mappings.

8.16.6.1. DAC MONITOR LIST TABLE

DMxMap	Variable	Description	DAC Out Units
0	AnalogOutx	Actual Analog Output Command	V/V
1	VelFB	Measured Velocity (DM2 Default)	1 V/krpm
2	VelCmdA	Actual Velocity Command (VelCmdA)	1 V/krpm
3	VelErr	Velocity Error	1 V/krpm
4	FVelErr	Compensated Velocity Error	1 V/krpm
5	Position	Measured Position*	1 V/Rev
6	PosError	Position Error*	1 V/Rev
7	PosCommand	Commanded Position*	1 V/Rev
8	Icmd	Commanded Torque Current	1 V/A
9	IFB	Measured Torque Current(DM1 Default)	1 V/A
10	AnalogIn	Filtered A/D Input	1 V/V
11	EncFreq	Encoder Frequency	1 V/Hz
12	EncPos	Encoder Position*	10 V/4096 Cnts
13	ItFilt	Filtered Output Current Amplitude	1 V/100%
14	HSTemp	Measured Heat Sink Temperature	1 V/°C
15		Commutation Electrical Angle*	1 V/Cycle
16	IR	Motor Phase R Output Current	1 V/A
17	IS	Motor Phase S Output Current	1 V/A
18	IT	Motor Phase T Output Current	1 V/A
19		Motor Phase R Voltage Duty Cycle	1 V/100%
20		Motor Phase S Voltage Duty Cycle	1 V/100%
21		Motor Phase T Voltage Duty Cycle	1 V/100%
22	VBus	Drive Bus Voltage	1 V/V
23	ResPos	Resolver Absolute Position*	1 V/Rev
24		Commanded non-torque current	1 V/A
25		Measured non-torque current	1 V/A
26		Torque Voltage Duty Cycle	1 V/100%
27		Non-torque Voltage Duty Cycle	1 V/100%
28	VelCmd	Velocity Command (VelCmd)	1 V/krpm
65536	No change to variable selection, turn range clamp off		
65537	No change to variable selection, turn range clamp on		

*These variables are allowed to wrap around when the signal exceeds the output voltage range.

8.16.6.2. J4 ANALOG AND DIGITAL I/O INTERFACE SCHEMATICS

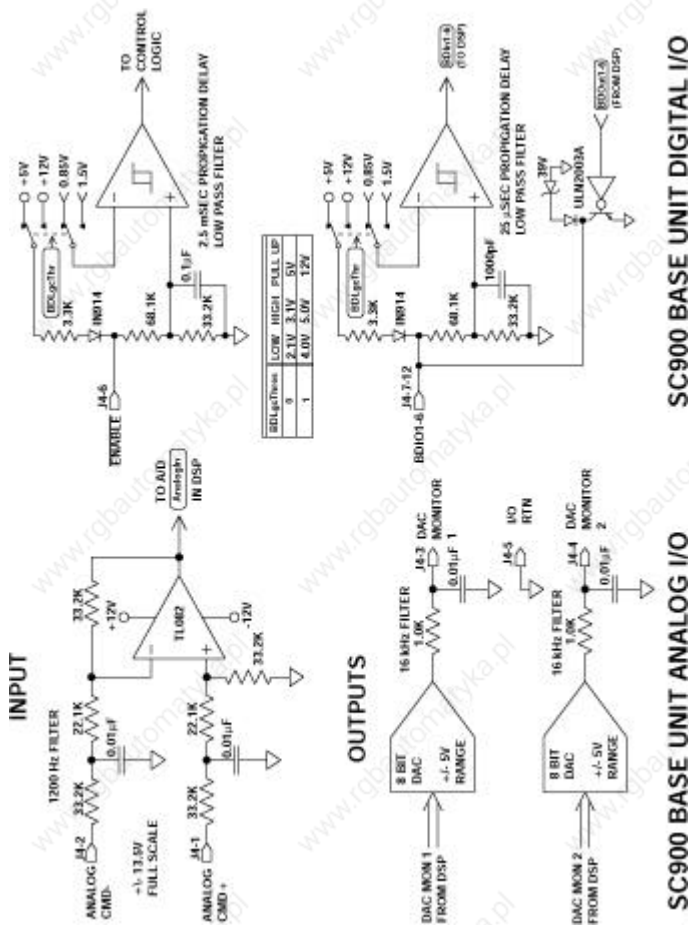

I/O RTN J4-5, 13, 18	This terminal is signal common for the analog and digital inputs and outputs.
Enable Input J4-6	This input is used to enable the drive and is active low. The output stage is disabled when this input is inactive. There is a 3.3 kΩ resistor and diode in series to the internal pull up voltage. A minimum drive sink capability of 5 mA is recommended and the maximum external pull up voltage is 30 VDC with respect to I/O RTN. This signal is detected with 1 V p-p hysteresis and a selectable center point for the logic trip thresholds which also selects the pull up voltage. With the BDLgcThr parameter set to 0 the trip voltages are 2.1 and 3.1 volts with 5 volt nominal pull-up while with BDLgcThr set to 1 the trip voltages are 4.0 and 5.0 with a 12 volt nominal pull-up. This input is filtered with a 2 ms time constant low pass filter to prevent false triggering from noise.
BDIO 1, 2, 3, 4, 5, 6 Bi- directional J4-7, 8, 9, 10, 11, 12	<p>These six I/O connections are user programmable discrete inputs or outputs. As outputs they are open collector with 30 volt with respect to I/O RTN and 100 mA current sinking maximum ratings. These outputs are not short circuit proof. BDIO 6 has a higher maximum current sinking rating of 200 mA. As inputs these signals are detected with 1 V p-p hysteresis and a selectable center point for the logic trip thresholds. With the BDLgcThr parameter set to 0 the trip voltages are 2.1 and 3.1 volts with 5 volt nominal pull up while with BDLgcThr set to 1 the trip voltages are 4.0 and 5.0 with a 12 volt nominal pull up. These inputs are filtered in hardware with a 20 μs time constant low pass filter for noise suppression. On each line there is a 3.3 kΩ resistor and a diode in series to the internal pull up voltage. A minimum drive sink capability of 5 mA is recommended to fully pull these inputs to a logic low. During AC power down or during the power up reset period these lines are held in the open collector state.</p> <p>Each of the BDIOs is set and read by software every 2 mSec. Each one can be configured to be any of the available functions and the configuration can be changed on the fly via digital communications to an Option Card. The user's default configuration is stored in the non-volatile memory. The present state of each of these lines as well as the state of commanded outputs can be read via digital communications on an Option Card. The logic polarity of these signals is also software programmable. That is, an input or an output can be defined to be active low or active high. For edge triggered functions the active edge is programmable.</p> <p>The list below describes the subset of the available functions and the mappings used as the factory defaults for each of the BDIOs.</p>

Fault Reset
Input

BDIO 1: This input is used to reset the amplifier following a fault. This input is programmed active low so that an open circuited input does not activate the function. During Fault Reset active the output stage is disabled and the reset condition will be held in hardware for approximately 0.1 sec after Fault Reset is returned inactive.

CwInh Input

BDIO 2: This input prevents further motion in the clockwise shaft motion direction. If the shaft is already moving in the clockwise direction, the motor decelerates to zero velocity with the maximum torque allowed by the user set output current limits. This input has no effect on motion in the counter-clockwise direction. This input is programmed active low so an open circuited input does not activate the function. This input is useful for a clockwise over travel limit switch.

Status display will alternate between “8 ” and an **8** when the limit input is affecting motion.

CcwInh Input

BDIO 3: Analogous to the CwInh input, except that this input prevents counter-clockwise motion. Status display alternates between “8 ” and **8**.

Input Mapped
Off

BDIO 4: Input Mapped Off

Brake Output

BDIO 5: This output is high (i.e. open collector) when the control power is off, or when control voltage is on and the drive is disabled (Enabled = 0). This output is pulled low otherwise. This output is intended to drive a normally open relay that in turn powers a mechanical brake on the motor shaft for applications that require a positive shaft lock when the servo drive is off.

Fault Output

BDIO 6: This output is high (i.e. open collector) when the drive is faulted or has no control power. This line can be used to indicate a problem with the drive.

CH A OUT
CH A OUT ,
CH B Out ,
CH B OUT
Outputs J4-14,
15, 16, 17

These two output pairs are differential TTL incremental position signals generated by the Resolver feedback electronics. These outputs are quadrature encoder to emulate an optical encoder. The resolution of these signals, i.e. the emulated line count, is set by the EncOut parameter. These outputs are buffered by 26LS31 type RS-422 compatible line drivers. Maximum recommended load current is ± 20 mA, which corresponds to a minimum line-to-line load resistance of 100 W. This drive capacity corresponds to 10 RS-422 compatible inputs such as the SC900 encoder inputs. These outputs are indefinitely short circuit (to I/O RTN) proof.

CH Z OUT**CH Z OUT**

Outputs J4-19, 20

These two terminals function as a differential, TTL marker pulse. The output pulse occurs once per motor shaft revolution starting at resolver position = 0 and its width is approximately one quadrature encoder width. This output comes from an 26LS31 type RS-422 compatible line driver. Maximum recommended load current is ± 20 mA, which corresponds to a minimum line-to-line load resistance of 100 Ω . This drive capacity corresponds to 10 RS-422 compatible inputs such as the SC900 encoder inputs. This output is indefinitely short circuit (to I/O RTN) proof.

Encoder Inputs**CH A IN, CH A IN,****CH B IN, CH B IN,**

Step +, Step -, Dir +,

Dir -, Step Up +,

Step Up -, Step Dn

+, Step Dn - J4-21,

22, 23, 24

These inputs are used as a quadrature encoder, step and direction, or up and down count format incremental signal source. The decoding mode is set by the EncMode parameter. The scale factor of this incremental position command input is fully adjustable with software parameters. Full decoding speed or more noise immune slow speed decoding is software selectable.

These two input pairs are differential and are detected by 26LS32 type RS-422 compatible line receivers. As differential inputs, the recommended common mode range is $< \pm 7$ V with respect to I/O RTN and the guaranteed differential voltage logic thresholds are $> \pm 0.2$ V. Recommended drivers should be able to source and sink 3 mA to/from these inputs. Each of these inputs have internal bias networks to allow easy connection to single ended sources. When an input is open circuited it will bias itself to between 2.2 and 2.5 V, thus the remaining input pair terminal will have a single ended guaranteed logic low for inputs < 2.0 V and a guaranteed logic high for inputs 2.7V. These levels are compatible with a TTL driver combined with a pull up resistor. Pull up resistor should be 470 Ω .

+5 VDC, +5 VDC

RTN Output J4-25,

18

These two connections provide an auxiliary power supply for the user. This output is 5 VDC $\pm 5\%$ and is I/O RTN short circuit protected. This supply goes to the option card and may also appear on an option card I/O connection point. For example, the +5 VDC on the OC930 J31 connector. The maximum load limit for all connections to this supply is 200 mA.

8.16.6.3. J4 ENCODER I/O INTERFACE SCHEMATICS DIAGRAM

8.16.6.3.1. Encoder Inputs

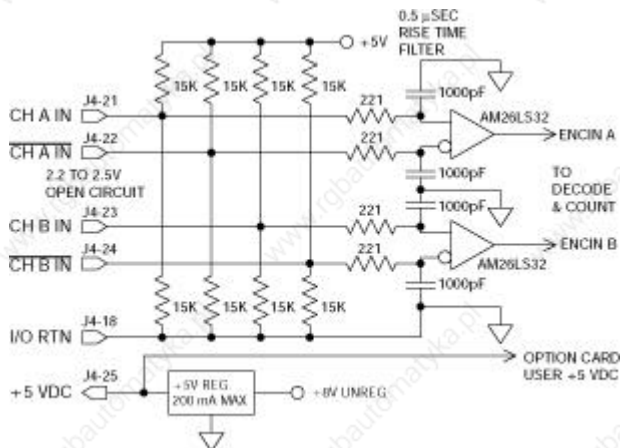

8.16.6.3.2. Emulated Encoder Outputs

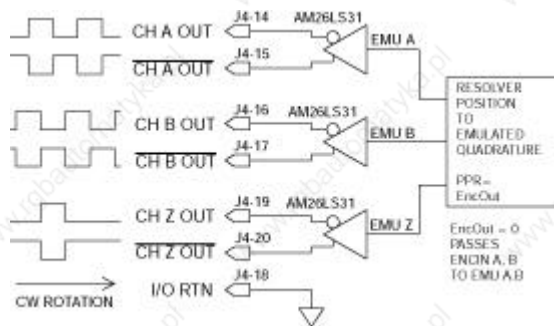

8.17. Operating Without an Option Card

The SCE900 base servo drive can operate with or without an option card. However, the drive is shipped from the factory unconfigured; with null parameters. Therefore, the first step in using a drive is to set the parameters by configuring the drive. All of the adjustments are saved in non-volatile Personality EEPROM. The EEPROM has a minimum life of 100,000 writes with 1,000,000 being typical. If cost economy or the security of preventing parameter changes in the field is desired, the base SCE900 can have parameters stored in its non-volatile memory via an option card and then the option card removed. When a drive powers up it will always load the parameters from the internal non-volatile memory. If there is an option card plugged in at power up and the internal non-volatile memory is unconfigured, then the drive will check the parameter memory on the option card and if it is configured will load it instead. This allows the drive's parameter personality to reside on the removable option card which allows easy replacement of a broken base servo and keeping the custom parameters of that axis without down loading from a PC again. If the internal non-volatile memory is not configured and there is no option card or the option card non-volatile memory is also unconfigured the drive will display **UC** on the status LED and will not allow the power output to be enabled.

For additional information on configuring a base SCE900 to operate without an option card plugged in, see the *MA930 – OC930 Hardware and Software Reference Manual*.

8.18. Diagnostics and Protection Circuits

The drive is fully protected against “normal” abuse and has a 7 segment LED visible on the front panel to indicate drive status. The base servo drive has the following specific protections:

Output motor short circuit protection line-to-line and line-to-neutral.

Interface to Danaher Motion Pacific Scientific's standard motor PTC or a normally closed thermostat to sense motor over temperature.

Internal monitoring of the power stage heat sink temperature for drive over temperature.

Bus over voltage detection.

Bus under voltage fault with adjustable threshold.

Incorporating the measured heat sink temperature there is an excessive current $I \cdot t$ fault. This fault limits the peak current time and intelligently changes the continuous current fault trip dependent on the measured heat sink temperature to limit the continuous output current.

Control voltage under voltage detection.

The auxiliary +5V output is short circuit to I/O RTN protected.

All control outputs are short circuit to I/O RTN protected.

When a drive is powered up without valid personality parameters the power stage cannot be enabled and no damage occurs to the drive.

If there is an option card plugged in at power up, then the drive will fault if the option card is unplugged while the power is still on.

The digital signal processor has a watchdog/throughput fault to help detect drive software errors.

8.18.1. Fault Sequence

The following sequence occurs when a fault is generated by the protection circuits. The fault source is latched, the output stage is disabled, the fault mappable output function is activated, and the status display indicates the appropriate blinking fault code. Faults are cleared by activating the Fault Reset input or by cycling the 120/240 VAC Control Power.

8.18.2. Fault Codes

The Status LED Code List table lists the status display codes shown on the system status LED. In the basic product, the LED decimal point is not used; it is reserved for use with option card accessories. A quick blinking display implies a hard fault. If an entry is not specifically listed as blinking then the display is steady and if listed as just blinking then the display blinks quickly. If an entry shows multiple characters then the characters alternately flash between the two values with unequal blank display pauses between to help indicate the intended character order.

See the following tables for a detailed list of system status LED codes and their possible causes.



8.18.3. Status LED Code List

Status Code	Description
0	No faults, power stage disabled, control voltage OK.
8	No faults, power stage enabled, control voltage OK.
8 ⁻ Alternating	No faults, power stage enabled, CcwInh active preventing CCW motion.
8 ⁻ Alternating	No faults, power stage enabled, CwInh active preventing CW motion.
8 ⁻ Alternating	No faults, power stage enabled, CwInh and CcwInh both active preventing motion.
7 ⁻ Blinking	Velocity feedback (VelFB) over speed To further identify this fault see software variable ExtFault: ExtFault = 1 VelFB > 21038 RPM ExtFault = 2 VelFB > max(VelLmtxx)*1.5
2 ⁻ Blinking	Motor over temperature
3 ⁻ Blinking	Drive over temperature
4 ⁻ Blinking	Drive I*t
5 ⁻ Blinking	SC9x3: Line-neutral over current
6 ⁻ Blinking	Control ±12 V under voltage
7 ⁻ Blinking	Output over current or Bus over voltage
8 ⁻ Blinking	Shunt regulator overload
8 ⁻ Blinking	Bus over voltage detected by DSP
b ⁻ Blinking	Auxiliary +5V low
c ⁻ Blinking	Not assigned
d ⁻ Blinking	Not assigned
*E	Processor throughput fault

Status Code	Description
*E Blinking	Control power AC line dip or power up self test failure
	To further identify this fault see software variable ExtFault:
	ExtFault = 1 Calibration data corrupted
	ExtFault = 2 Excessive DC offset in current feedback sensor
	ExtFault = 3 DSP incompletely reset by line power dip
	ExtFault = 6 Excessive DC offset in Analog Command A/D
	ExtFault = 7 Unable to determine option card type
	ExtFault = 8 DSP stack overflow
	ExtFault = 10 Software and control card ASIC incompatible
	ExtFault = 11 Actual Model not same as stored in NV memory
	ExtFault = 12 Unable to determine power stage
ExtFault = 15 RAM failure	
ExtFault = 16 Calibration RAM failure	
E1 Alternating	Bus under voltage, bus voltage VBusThresh*
E2 Alternating	Ambient temperature too low
E3 Alternating	Encoder commutation alignment failed (Only for CommSrc = 1)
E4 Alternating	Software and non-volatile memory versions not compatible
*E5 Alternating	Control card hardware not compatible with software version
E6 Alternating	Drive transitioned from unconfigured to configured while enabled
E7 Alternating	Two AInNull events too close together
F1 Alternating	Position following error fault
F3 Alternating	Parameter memory error
	To further identify this fault see software variable ExtFault:
	ExtFault = 13 Control card non-volatile parameters corrupt
	ExtFault = 14 Option card non-volatile parameters corrupt
UC Alternating	Unconfigured drive

*These fault states can not be reset with the Fault Reset function and require the line control power to be cycled.

8.18.4. Status LED Troubleshooting

Status Code	Possible Cause
1 Blinking	Loose or open circuit wiring to the resolver feedback connector J3. Actual motor speed exceeded $1.5 * (\text{Max Of } \text{VelLmtLo} \text{ or } \text{VelLmtHi})$ or 21,038 rpm which is the over speed trip level.
	For Encoder velocity feedback (RemoteFB = 2) check that EncIn is set properly to correctly scale the VelFB units.
2 Blinking	Loose or open circuit wiring to motor PTC thermal sensor (J3-8 & J3-9). High ambient temperature at motor.
	Insufficient motor heat sinking from motor mounting.
	Operating above the motor's continuous current rating.
	Inoperative cooling fan.
3 Blinking	High drive ambient temperature. Restriction of cooling air due to insufficient space around unit.
	Operating above the drive's continuous current rating.
	Inoperative cooling fan.
	 See HSTemp, ItFilt, and ItF0 for information on measuring thermal margin in an application.
4 Blinking	Mechanically jammed motor. Motion profile accelerations too high.
	Machine load on the motor increased perhaps by a friction increase.
	Problem with wiring between drive and motor yielding improper motion.
	Drive and/or motor under sized for application.
	 See HSTemp, ItFilt, and ItF0 for information on measuring thermal margin in an application.
5 Blinking	Motor power wiring (J2-2, 3, or 4) short circuit line-to-ground (neutral).
	Motor power cable length is enough longer than the data sheet specification to cause excessive motor line to earth ground (neutral) capacitance.
6 Blinking	Insufficient control AC voltage on J1-5 to J1-6. External short on signal connector.
	Internal drive failure.

Status Code	Possible Cause
7 Blinking	<p>Motor power wiring (J2-2, 3, or 4) short circuit line-to-line or line-to-ground (neutral). Internal motor winding short circuit.</p> <p>Insufficient motor inductance causing output over current faults.</p> <p>KIP or KII improperly set causing excessive output current overshoots.</p> <p>Motor AC power input voltage too high.</p> <p>Disconnected regeneration resistor on J5.</p> <p>External regeneration resistor ohmage too large yielding Bus OverVoltage fault.</p>
8 Blinking	<p>Excessive regen in application.</p> <p>Improper external regen wiring or components on J5.</p>
A Blinking	Actual bus over voltages are usually, but not always, detected and displayed as a blinking 7 fault. See that entry for more information.
b Blinking	Short circuited wiring on the output (J4-25).
	Load exceeds the current rating of this supply.
E Solid	Drive hardware failure or drive software bug.
E Blinking	See the status variable ExtFault for further information about the exact failure.
E7 Alternating	Check the measured bus voltage (VBus) and the fault threshold (VBusThresh) to make sure they are consistent.
E2 Alternating	Ambient temperature is below drive specification. Drive's internal temperature sensor has a wiring problem.
E3 Alternating	Problems with encoder feedback wiring to J4 when CommSrc = 1. Load inertia more than 100 times the motor inertia leading to settling times long compared to the 2-second encoder commutation alignment. Artificially extend the alignment time by pulsing the hardware enable (J4-6).
E4 Alternating	OC930-001-01 (drive software upgrade card) was used to set up an old drive. Then either no or a standard OC930-001-00 (no software upgrade option card) is installed, resulting in the old software being used in the drive.

Status Code	Possible Cause
E5 Alternating	Attempt to upgrade the drive's software will not work. Contact factory for upgrade details.
	Resolver wiring error. Remove J2 and J3 connectors. Cycle AC power. If fault is now a 2, correct resolver excitation wiring.
E8 Alternating	Unconfigured drive (Status LED alternates U, C after power up) was fully configured with the drive motor power enable active. This fault can be reset or the control AC power cycled to get the drive-motor operating.
E7 Alternating	The AInNull function was re-activated too soon after going inactive. This can be caused by switch bounce on the input pin mapped to activate AInNull.
F1 Alternating	The motor is either stalled or partially jammed or the value for PosErrorMax is set too sensitive for the loop tuning and commanded motion profiles.
F3 Alternating	Glitch while last saving the NV parameters. Swapped option card has corrupted NV memory contents. Hardware problem with the NV memory. See ExtFault status variable to determine whether NV memory corruption is inside the drive or on the option card. Re-download parameters to restore drive operation.

8.19. Power Up/Down Sequencing

Upon power up, the 7 segment Status LED displays "P A C S C I", pause, "-", pause, the digital communications address, if any, in HEX, any option card specific display, and then the Status LED displays the appropriate operational state. However, the drive is fully functional in less time than it takes for the power up message. Proper operation typically commences less than 2 seconds after the control power is up. This time roughly corresponds to the drive being fully operational by the time the "A" in "P A C S C I" is on the display. The power up booting of the drive software is somewhat analogous to that on a desk top PC with the drive like a hard disc and the option card like a floppy. If the drive has no option card or the option card itself has no drive software on it, the drive uses the software on the control card. If there is an option card plugged in that does not have drive software on it, the drive uses that software and the Status LED power up message includes "o P t" after the hex communications address. This capability allows an option card to fully re-program the base servo drive as needed or allows a standard option card to be bought with the latest base drive software to field upgrade an older option card. An example of a drive software upgrade option card is OCE930-001-01.

The drive and motor behave in a well defined manner without damage to the drive during intermittent or transient AC line conditions. The system also behaves well when only the bus or only the control AC input voltages are powered and/or intermittent. The drive can be safely powered up in any sequence with any of the control inputs in any state and when the power up reset time is over, the drive immediately begins the appropriate operation. For example, with the Enable input hard-wired to I/O RTN and the motor and control AC power applied simultaneously, the power stage enables and the drive controls the shaft immediately after the power up reset time of less than 2 seconds is over. If there is a fault upon power up, the drive goes from power up reset to the fault state immediately without enabling the drive.

Although safe, it is not recommended that the motor bus power be applied with the control power already statically on and the drive enabled when the motor inductance is near the drive's minimum inductance specification. If this sequence is applied with a motor having the drive's minimum inductance, the drive may fault on over current. Either apply both motor and control power simultaneously or, if control power is already on, apply motor bus power with the drive disabled.

The diagnostic information displayed by the 7-segment LED is available over the digital communications link if applicable.

When power is removed from the drive, the drive continues operating until a control supply voltage fault or a bus voltage fault is detected.

8.20. PC User Interface

The IBM PC and compatibles user interface utility for the SCE900 with OCE930 option card runs under Microsoft Windows 3.1 or Windows95 and is called 930WIN.EXE.

8.20.1. MA930

The following procedures illustrate how to install and launch the utility with brief instructions. For complete information on this utility please see the *MA930 – OC930 Hardware and Software Reference Manual*.

8.20.1.1. INSTALLING 930WIN.EXE

To install 930 Dialogue for Windows:

1. Insert the 930 Dialogue for Windows diskette in your disk drive (**A:** or **B:**).
2. Start Windows.
3. Choose **Run** from the **File** Menu of Program Manager.
4. At the command line, type **A:\setup930** (or **B:\setup930**).
5. Press **<Enter>** or click **<OK>**.

8.20.1.2. STARTING 930WIN

To begin using 930 Dialogue for Windows

1. Open the **930WIN Group** in Program Manager, if not already open.
2. Double click on the 930WIN icon to launch the program.
3. Once in the utility, go to the **Options** Menu.
4. Select **Port Configuration** to specify a serial port for communication. At this point the software is fully installed, configured, and ready for use.

SCE900 drives are shipped from the factory in the Unconfigured state.

When they are first powered up, they flash **UC** and will not run a motor.

Drives are easily configured with the 930WIN.EXE utility.

8.20.1.3. CONFIGURING A DRIVE

1. Go to the **Options** menu.
2. Select **Drive Set Up**.
3. At the next screen select the default Auto mode by clicking the return key.
4. At this point answer the questions as they come up. When this short process is done the drive is set up for the motor that the user keyed in and the drive will drive the specified unloaded motor quite well and should allow the user to experiment with 930.EXE's many other features.

For further information on this utility use the on line help and experiment with it. In the **Drive** menu select **Variables** to experiment with individual drive parameters.

8.21. Customer Support/Contact Information

Danaher Motion Pacific Scientific technical documentation is updated periodically and may be changed without notice. The latest documentation can be found on our website.

For information on this product or where to purchase near you, contact: your local distributor.

Danaher Motion Customer Support

Phone: (815) 226-2222

Fax: (815) 226-3080

Email: customer.service@danahermotion.com

Website: www.danahermotion.com