

Miniature Surface-Mount Ambient Light Photo Sensor

Data Sheet

Description

The APDS-9009 is a low cost analog-output ambient light photo sensor in an 8-pin ODFN lead-free surface mount package. It consists of a photo sensor, whose spectral response is close to the CIE standard photopic observer, as show in [Figure 2](#). The APDS-9009 is ideal for applications in which the measurement of ambient light is used to control display backlighting. Mobile appliances such as the mobile phones and PDAs that draw heavy current from display backlighting will benefit from incorporating these photo sensor products in their designs by reducing power consumption significantly.

Application Support Information

The Application Engineering Group is available to assist you with the application design associated with APDS-9009 ambient light photo sensor module. You can contact them through your local sales representatives for additional details.

Features

- Spectral responsivity close to that of human eye
- 8-pin ODFN lead-free surface-mount package
 - Height – 0.34 mm
 - Width – 2.00 mm
 - Depth – 2.00 mm
- Low sensitivity variation across various light sources
- Recommended operating temperature: –40 °C to 85 °C
- Vcc supply 1.8 to 5.5 V
- Lead-free package, RoHS compliance
- Output linearity across wide illumination range

Applications

- Detection of ambient light to control display backlighting
 - Mobile devices – Mobile phones, PDAs
 - Computing devices – Notebooks, Webpads
 - Consumer devices – TVs, Video Cameras, Digital Still Camera
- Automatic Residential and Commercial Lighting Management
- Electronic Signs and Signals

Ordering Information

Part Number	Packaging Type	Package	Quantity
APDS-9009	Tape and Reel	8-pin ODFN package	2500

Typical Application Circuit

Figure 1 Typical Application Circuit for APDS-9009

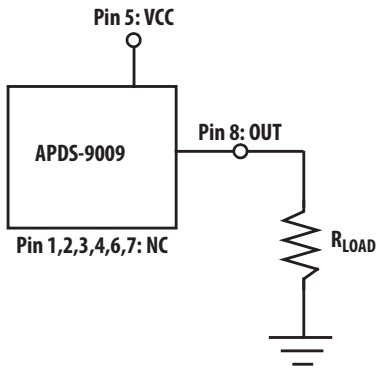

Component	Recommended Application Circuit Component
R _{LOAD}	1 k ohm

NOTE See Figure 11 for General Luminance Vs. Typical Output Voltage for different R_{LOAD} values.

Absolute Maximum Ratings

For implementations where case to ambient thermal resistance is 50 °C /W.

Parameter	Symbol	Min.	Max.	Units
Storage Temperature	T _S	-40	85	°C
Operating temperature	T _A	-40	85	°C
Supply Voltage	V _{CC}	0	6	V

Recommended Operating Conditions

Parameter	Symbol	Min.	Max.	Units	Conditions
Supply Voltage	V _{CC}	1.8	5.5	V	

CAUTION It is advised that normal static precautions be taken in handling and assembly of this component to prevent damage and/or degradation which may be induced by ESD

I/O Pins Configuration Table

Pin	Symbol	Description
1	NC	No Connect
2	NC	No Connect
3	NC	No Connect
4	NC	No Connect
5	VCC	VCC
6	NC	No Connect
7	NC	No Connect
8	I _{out}	Out

Figure 2 Relative Spectral Response Vs. Wavelength

