



Emergency-Stop Relay

Basic Unit
Cross Monitoring
According to EN 60204 - 1 and EN 954 - 1
Single or Dual E-Stop Control Circuit Possible
3 NO Safety Contacts, 1 NC Control Contact
Rated Voltage in the E-Stop Control Circuit: 24 V DC

SNO 2005	EN 60204-1	For Stop Category	0
	EN 954-1	Safety Category	4

1

SNO 2005-xx

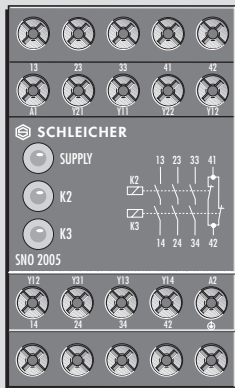

For Example

- ▶ Protection of persons and machines
- ▶ In combination with automation systems
- ▶ For immediate isolation of the power supply - Stop category 0
- ▶ Monitoring of sliding safety screens
- ▶ Protective measures in safety areas

Function

After the supply voltage is applied to terminals A1/A2, and if the E-STOP momentary contact switch is not activated the relay K1 is energized with the RESET switch. The control logic of relay K1 triggers the relays K2 and K3. The latter become self-locking through their own contacts. At the same time, the relay contacts of K2 and K3 de-energize relay K1 which goes over into its off-position. After this switch-on phase, the three enabling current paths, which are intended for the output, are closed (terminals connection for: 3 enabling current paths = 13/14, 23/24, 33/34) and 1 control contact is open (terminals connection 41/42). Three LEDs provide a display, and these LEDs are associated with the safety channels K2, K3 and the supply voltage.

If the E-STOP switch is activated, the current leads for the K2 and K3 relays are interrupted. The enabling current paths at the output are opened and the control contact is closed. With two-channel wiring of the E-STOP circuit, it is possible to monitor the presence of a short circuit in the cables connected to it (cross monitoring) and ground faults. An internal electronic circuit protects the emergency-stop relay from damages. After eliminating the fault the item will return into operation within 2 s ca.

The emergency stop safety relay can be operated with or without RESET monitoring. In case of connection with RESET monitoring (terminal Y13) the activation of the item occurs only with the falling edge of the RESET key. This means that only a static operation of the item is possible with this function. To start the item the RESET button has to be closed and then released. In this case an automatic start of the item by using a jumper for the RESET button cannot be performed (see Function Diagram FD 0221-14-1 W1).

Operation without monitoring of the RESET switch (device connection Y14) is suitable for dynamic operation (automatic start). The RESET switch can be shunted. This function finds application in the area of protective screens (see Function Diagram FD 0221-14-2 W1).

Function Diagram

FD 0221-14-1 W1

SNO 2005-xx Emergency Stop Application

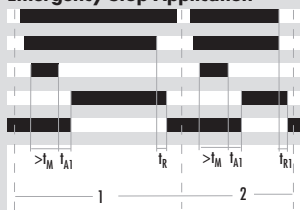

A1/A2 Power Supply, LED SUPPLY
 Y12, Y31 E-STOP
 Y13 RESET (with RESET switch monitoring)
 K2, K3, 13/14, 23/24, 33/34, LED K2, LED K3
 41/42

t_{A1} = Response time (with RESET switch monitoring)
 t_R = Release time for E-STOP
 t_{R1} = Release time when main supply (A1/A2) is interrupted

t_M = Minimum switch-on time
 1 = E-STOP via Y12, Y31
 2 = E-STOP via A1/A2

Emergency Stop Application

FD 0221-14-2 W1

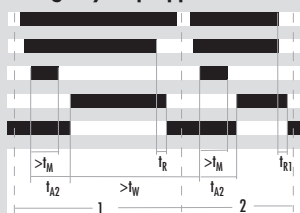

A1/A2 Power Supply, LED SUPPLY
 Y12, Y31 E-STOP
 Y14 Reset (without RESET switch monitoring)
 K2, K3, 13/14, 23/24, 33/34, LED K2, LED K3
 41/42

t_{A2} = Response time (without RESET switch monitoring)
 t_R = Release time for E-STOP
 t_{R1} = Release time when main supply (A1/A2) is interrupted

t_M = Minimum switch-on time
 t_W = Recovery time
 1 = E-STOP via Y12, Y31
 2 = E-STOP via A1/A2

Protective Gate Application

FD 0221-14-3 W1

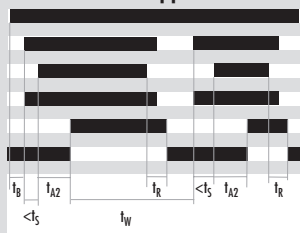

A1/A2 Power Supply, LED SUPPLY
 Y12 Channel 1
 Y22 Channel 2
 Y14 Reset
 K2, K3, 13/14, 23/24, 33/34, LED K2, LED K3
 41/42

t_{A2} = Response time
 t_B = Availability time, (only for AC devices must be ≥ 100 ms)
 t_R = Release time
 t_S = Synchronization time
 t_W = Recovery time

Notes

- ▶ To multiply the enable current paths, expansion units or external contactors with positively driven contacts can be used

Connection Diagram

KS 0221-14 W1

SNO 2005-230

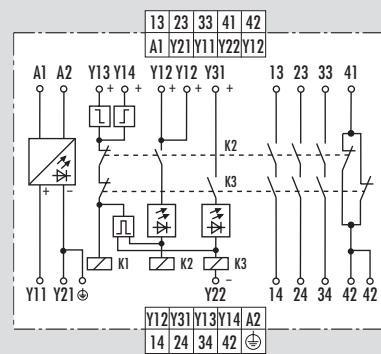



SNO 2005-xx

Application Example

A 1105

Single-Channel E-STOP Circuit without Monitoring of the RESET Switch

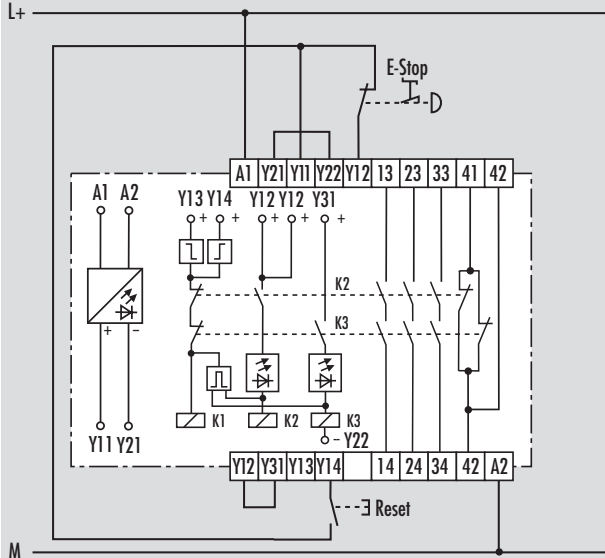

From the relay K3, both actuation connections (Y31, Y22) are conducted to terminals. In this way, the connection to be switched can be chosen at will. The opposite side must be set permanently on plus (Y11) or minus (Y21) by a wire shunt. If the terminal (Y22) is permanently connected to minus (Y21), an E-STOP momentary-contact switch with only one contact can be used.

Application Example

A 1106

Two-Channel E-STOP Circuit with Monitoring of the RESET Switch (to detect bridge faults)

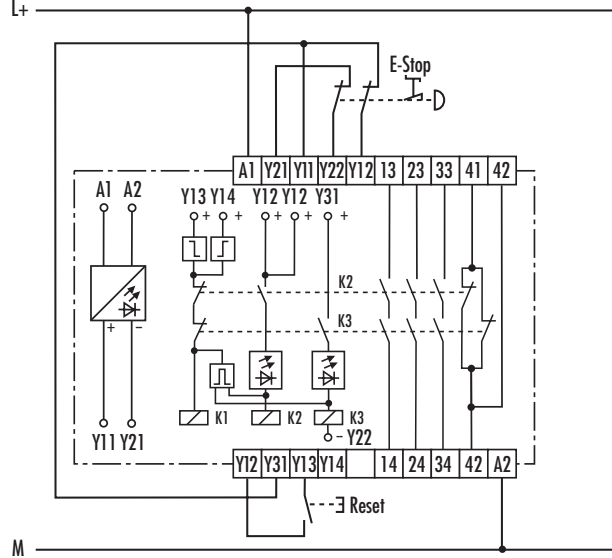

The two-channel E-STOP circuit will switch off even if one of the two contacts of the E-STOP momentary-contact switch does not open. If a fault occurs (for instance if the E-STOP contact connected to Y12 does not open), then the safety circuit is activated by the second (redundant) contact Y22. The enabling current paths 13/14, 23/24, and 33/34 open. If the lines leading to the E-STOP momentary contact switch are short circuited, the voltage at Y11, Y 21 is short circuited (cross-monitoring). The relays K2, K3 drop back into their initial position, and the electronic fuse responds. A line short through the RESET switch, which has occurred after the relay has been activated, is detected by means of the cyclic self-test with a new switching process, and the enabling current paths are prevented from switching through.

Application Example

A 1108

External Contact Expansion

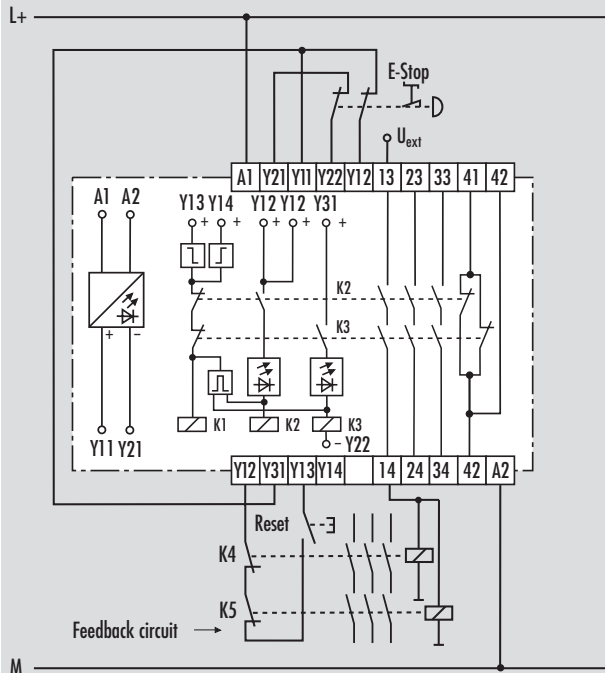

If the number of enabling current paths is not sufficient, two external contactors can be used for expansion. They are driven through one of the enabling current paths of the SNO 2005-xx. The function of the external contactors is monitored through their own normally-closed contacts. The normally-closed contacts are connected in series with the relay K1 (Y13). The contactors K4 and K5 must have positively driven contacts.

Application Example

A 1107

Two-Channel Sliding Protective Gate Monitoring (cross-monitoring)

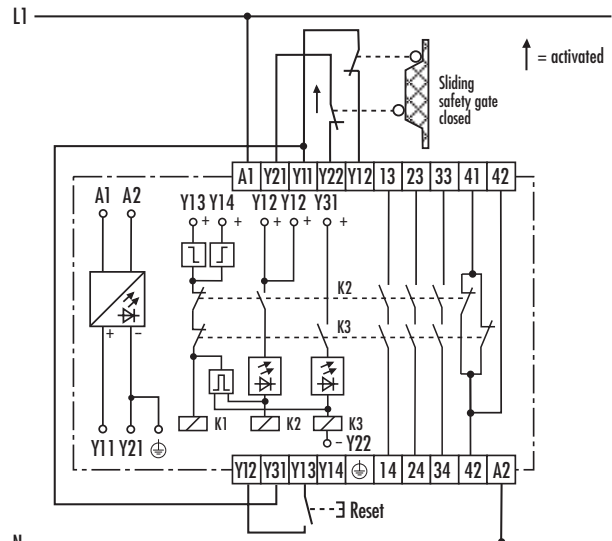

The position of the sliding protective gate is monitored via channel 1 (Y12) and channel 2 (Y22). The SNO 2005-xx is activated through the RESET switch. If the sliding protective gate opens, the E-STOP Relay again drops back into its de-energized state (enable current paths 13/14, 23/24, 33/34 open). If the protective gate is closed again, the E-STOP Relay can be activated again through the RESET switch.



Application Example

A 1125

Two-Channel Sliding Protective Gate Monitoring (Cross-Monitoring) with Automatic START

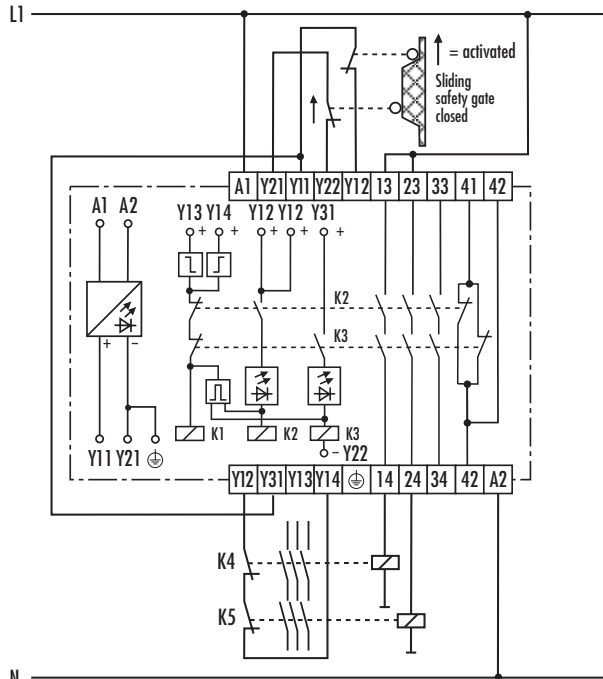

The position of the sliding protective gate is monitored via channel 1 (Y12) and channel 2 (Y22). The SNO 2005-xx can be activated only if the feedback circuit Y12/Y14 is closed (NC contacts of the contactors K4 und K5). A simultaneity check of 0,5 s approx. for the position switches is performed when closing channel 1 (Y12) before channel 2 (Y22). If channel 2 (Y22) is closed before channel 1 (Y12) there is no simultaneity check ($t = \infty$). If the sliding protective gate is opened the E-Stop relay goes back to its off-position (the enabling current paths 13/14, 23/24, 33/34 open). If the protective gate is closed again, the NC contacts of the contactors K4 and K5 allow the device to activate again (automatic START).

Application Example

A 1126

Two-Channel Sliding Protective Gate Monitoring with Automatic START (without Cross-Monitoring)

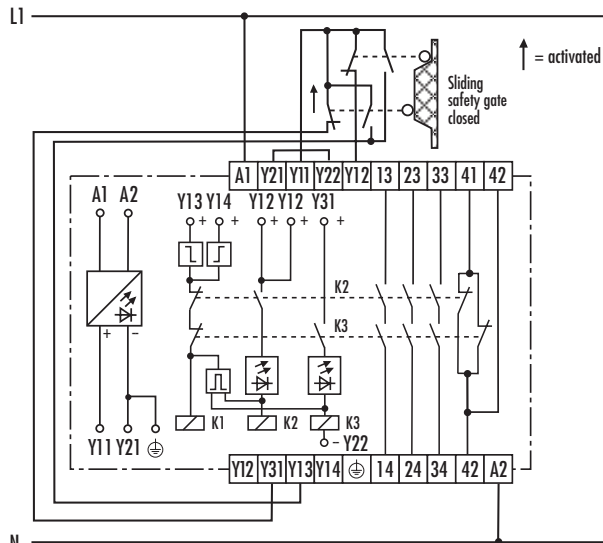

In this application example no simultaneity check ($t = \infty$) is performed.

Application Example

A 1127

Two-Channel Safety Mat Monitoring (Cross-Monitoring) with Manual START and RESET Key Monitoring

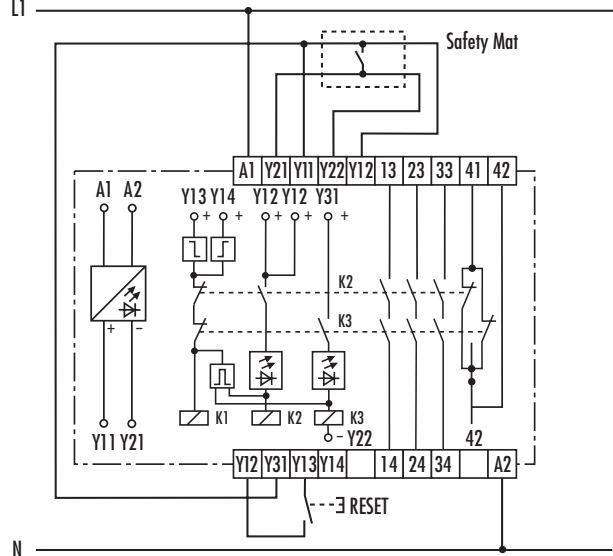

The function function corresponds to the one of the application example A 1106. As additional feature it is possible to connect all safety contact mats, safety contact strips or safety contact edges with forced guided contacts electrically isolated. The safety contact mats, strips and edges operate causing a short circuit between two wires. In case the value of the internal wire resistance in the safety mat, strip or bumper is $< 50 \Omega$ per channel and there is a presence of a short circuit between the channels (terminals Y11/Y12 and Y21/Y22) the item will be completely shut down. This is possible because the item is designed with the cross monitoring feature which requires a dual channel control circuit. Safety mats which operate causing a short circuit can only be connected to those items with AC external power supply.



Dimension Diagram

S7-4

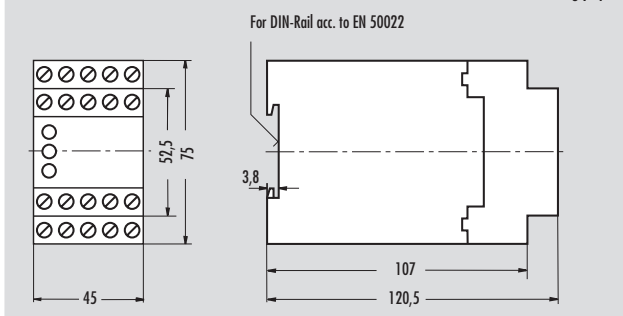

Approvals



Order Example

SNO 2005-24	24 V AC
SNO 2005-17	24 V DC

Type Rated Voltage



TECHNICAL DATA

FUNCTION According to EN 60204-1
Function Display
Function Diagram

POWER SUPPLY DATA

Rated Voltage U_N	V AC
Rated Voltage U_N	V DC
Rated Consumption at 50 Hz and U_N (AC)	VA
Rated Consumption at 50 Hz and U_N (AC)	W
Rated Consumption at U_N (DC)	W
Residual Ripple	V _{ss}
Rated Frequency	Hz
Operating Voltage Range	

CONTROL CIRCUIT

only for supplying the control inputs
Control Output Y11 with respect to Y21:

Line Resistance (Control Inputs)	Ω
Rated Output Voltage	V DC
No-Load Voltage (AC-Unit)	V DC
Rated Current	mA
Rated Short-Circuit Current I_K max.	mA
Fuse	
Response Time (PTC)	s
Recovery Time (PTC)	s

Control Inputs Y12, Y13, Y14, Y31:

Rated Current Input K1	mA
Rated Current Input K2, K3	mA
Response Time t_{A1} K2, K3 (with RESET monitoring)	ms
Response Time t_{A2} K2, K3 (without RESET monitoring)	ms
Release Time t_r for the E-Stop K2, K3	ms
Release Time t_R for Failure of the Network	ms
Minimum Swith-ON Time t_M for K1	ms
Recovery Time t_W (without RESET monitoring)	ms

OUTPUT CIRCUIT

Contact Equipment

Contact Type	
Contact Material	
Switching Voltage U_n	V AC/DC
Maximum Rated Current I_n per Contact	A
Maximum Total Current for all Contacts	A
Application Category According to EN 60947-5-1:1991	
Short-Circuit Protection, Max. Fuse Element Class gG	A
Permissible Switching Frequency	Switching Cycle/h
Mechanical Lifetime	Switching Cycle

GENERAL DATA

Creepage and Clearance Distances Between Circuits According to DIN VDE 0110-1:04.97: Rated Withstand Voltage	kV
Over-Voltage Category	
Contamination Level	
Design Voltage	V AC
Test Voltage U_{eff} 50 Hz acc. to DIN VDE 0110-1, Table A.1	kV
Protection Class Housing/Terminals acc. to DIN VDE 0470 Sec. 1:11.92	
Radiated Noise	
Noise Immunity	
Ambient Temperature, Working Range	°C
Dimension Diagram	
Connection Diagram	
Weight	kg
Accessories	
Approvals	

GENERAL TECHNICAL SPECIFICATIONS

SNO 2005-xx

Emergency - Stop Relay
3 LEDs, green
FD 0221-14-1 W1, FD 0221-14-2 W1

	24	115	120	230
24				
	3,2	3,2	3,2	3,2
	2,5	2,5	2,5	2,5
1,0				
2,4				
50 to 60				
0,85 to 1,1 x U_N				

≤ 70
24
≤ 40
40
800
AC: Short-Circuit Proof Transformer
DC: PTC-Resistance
3
2

40
15
80
500
50
100
50
500

3 N.O. Safety Contact
1 N.C. Control Contact
Forced Contact
Ag - Alloy; Gold-Plated
230/230
18
AC-15: U_e 230 V AC, I_e 6 A (3600 Sch/h)
DC-13: U_e 24 V DC, I_e 6 A (360 Sch/h)
DC-13: U_e 24 V DC, I_e 3 A (3600 Sch/h)
6
3600
10×10^6

4
III
3 Outside, 2 Inside
300
2,21
IP 40/IP 20
EN 50081-1:03.93, -2:03.94
EN 50082-2:1995

- 25 to + 55
S 7-4
KS 0221-14 W1
0,36 (AC-Unit), 0,3 (DC-Unit)
Holder Z 31
BG, CSA, SAG, UL

Page i.11