

MiCS-6814 with recommended supply circuit (top view)

R1 is 130 Ohms, R2 is 820 Ohms and R3 is 27 Ohms. These resistors are necessary to obtain the right temperatures on the three independent heaters while using a single 5 V power supply. The resulting voltages are typically $V_{hRED} = 2.4$ V, $V_{hOX} = 1.7$ V and $V_{hNH3} = 2.2$ V.

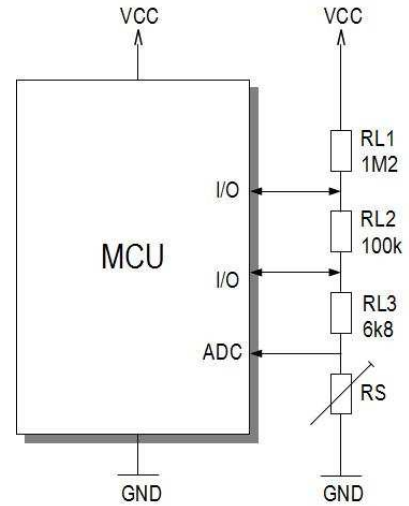

MiCS-6814 with measurement circuit (top view)

The example above shows the principle to read a resistance between 1 kOhms and 2MOhms with a 8bit A/D converter. Depending on the application and on the precision of the A/D converter, a single load resistor of 56 kOhms may be sufficient. Rload must be 820 Ohms at the lowest in order not to damage the sensitive layer.

Parameter RED sensor/OX sensor/NH3 sensor	Symbol	Typ	Min	Max	Unit
Heating power	P_H	76/43/66	71/30/60	81/50/73	mW
Heating voltage	V_H	2.4/1.7/2.2	-	-	V
Heating current	I_H	32/26/30	-	-	mA
Heating resistance at nominal power	R_H	74/66/72	66/59/64	82/73/80	Ω

Rating	Symbol	Value / Range	Unit
Maximum heater power dissipation	P_H	88	mW
Maximum sensitive layer power dissipation	P_s	8	mW
Voltage supply/Heating current	V_{supply}	4.9 – 5.1	V
Relative humidity range	RH	5 – 95	%RH
Ambient operating temperature	T_{amb}	-30 – 85	$^{\circ}C$
Storage temperature range	T_{sto}	-40 – 120	$^{\circ}C$
Storage humidity range	RH_{sto}	5 - 95	%RH

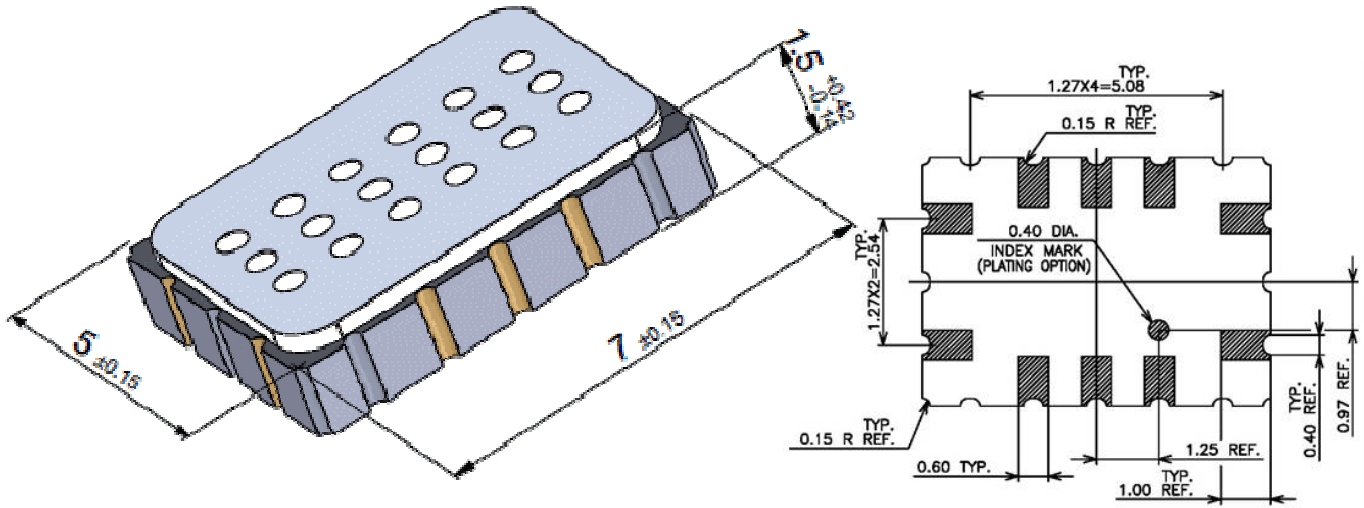

Package outline dimensions

The package is compatible with SMD assembly process.

Pin	Connection
A	Rs2
B	Rh1 RED, Rs1 RED
C	Rh1 NH ₃
D	Rs1 NH ₃
E	Rh2 NH ₃
F	Rs2 NH ₃
G	Rh2 RED
H	Rs2 RED
J	Rh1 OX, Rs1 OX
K	Rh2 OX

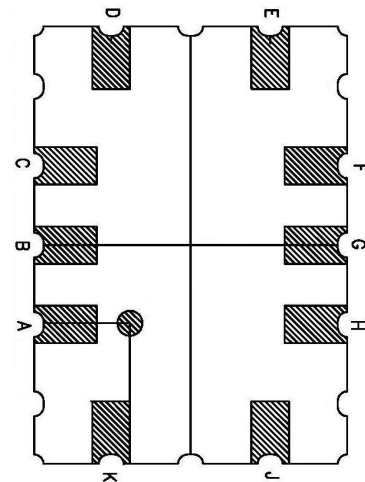

MiCS-6814 configuration (bottom view)

Sensor configuration

The silicon gas sensor structure consists of an accurately micro machined diaphragm with an embedded heating resistor and the sensing layer on top.

The MiCS-6814 includes three sensor chips with independent heaters and sensitive layers. One sensor chip detects oxidising gases (OX), the other sensor detects reducing gases (RED) and the other detects NH₃. The internal connections are shown above.