

FF-SRS5935

Dual Channel Emergency Stop Module Instructions for use



(pending)

⚠ WARNING

IMPROPER INSTALLATION

- Consult with US and/or European safety agencies and their requirements when designing a machine control, interface and all control elements that affect safety.
- Strictly adhere to all installation instructions.

Failure to comply with these instructions could result in death or serious injury.

PRODUCT DESCRIPTION

The FF-SRS5935 Emergency Stop modules are designed to be used in emergency stop circuits when danger to personnel or machinery is present. This device has two safety relays with positive-guided contacts to ensure redundancy.

This safety control module provides an emergency stop signal to the machine control circuitry. FF-SRS5935 helps to create a control reliable safety solution by providing redundancy and self-checking circuitry. Other features include higher current capability, a greater number of contacts (using an extension control module FF-SRE3081) and more capability than regular safety relays (an automatic restart and start/restart operation mode, cross fault monitoring, and external relays monitoring).



APPROVALS

CE	The product, packaging and documentation of FF-SR Series products carry the CE mark; the CE declaration of conformity is available upon request.
cULus (pending)	This product is pending approval by Underwriters Laboratories Inc. according to Canadian and U.S. safety requirements.
BG	German Berufsgenossenschaft E+MIII

DIRECTIVES COMPLIANCE

Machine Directive 89/392 EEC
Low Voltage Directive 73/23 EEC
Electromagnetic Compatibility Directive 89/336

REGULATIONS COMPLIANCE

Regulation	Title
OSHA 29 CFR 1910.212	General Requirements for (guarding of) All Machines
OSHA 29 CFR 1910.217	(Guarding of) Mechanical Power Presses

STANDARDS COMPLIANCE

Standard	Title
ANSI B11.1	Mechanical Power Presses
ANSI B11.2	Hydraulic Power Presses
ANSI B11.19	Safeguarding when Referenced by the Other B11 Machine Tool Safety Standards
ANSI/RIA R15.06	Safety Requirements for Industrial Robots and Robot Systems
UL508	Underwriters Laboratories
EN 292	Safety of Machinery - Basic Concepts, General Principles for Design
EN 60204	Safety of Machinery - Electrical Equipment of Machines
EN 954	Safety of Machinery - Safety related parts of control system

SPECIFICATIONS

Input	
Nominal voltage	120 VAC (-15%, +10%), 230 VAC (-15%, +10%), 24 VDC (-10%, +20%)
Nominal power consumption	24 VDC: 2 W; 230 VAC: 4 VA
Nominal frequency	50 to 60 Hz
Start time	Manual START function: 50 ms (-25%, +50%); Automatic START function: 1 s (-25%, +50%)
Nominal voltage at S11	24 VDC with 35 mA current $\pm 25\%$ (provided by control module)
Minimum voltage at S11	21 VDC when activated
Cable resistance between S11/S12 and S21/S22	68 \bullet (max.)
Output	
Contact complement	3 NO, 1 NC contacts
Response time	After opening of input (S11/12 or S21/22): 25 ms; Opening in supply circuit (L1(+)/A1): 50 ms
Contact type	Safety relay, positive-guided
Switching capability	Power factor = 1 with resistive load
Current range (min. to max.)	1 mA to 10 A (see caution)
Voltage range (min. to max.)	0.1 to 250 VAC/DC
Typical Electrical Life Expectancy	Power factor = 1 at 230 VAC/DC (note 1)
3A	1,000,000 operations
5A	500,000 operations
10A	220,000 operations
Typical Electrical Life Expectancy	Limitation factor (note 2)
0.3	0.45
0.5	0.70
0.7	0.85
1.0	1.00
Operating frequency	600 switching cycles/h
Fuse rating	6 A gL (max.)
Mechanical life	Ten million switching operations
General	
Temperature range	-15°C to +55°C (5°F to 131°F) at 90% humidity (max.)
Sealing	Housing IP 40; Terminals IP 20
Housing material	Thermoplastic
Vibration resistance	Amplitude 0.35 mm: Frequency 10 to 55 Hz
Conductor connection	1 x 4 mm ² solid (max.) [12 AWG] or 2 x 1.5 mm ² (max.) [16 AWG] stranded wire with sleeve
Conductor attachment	Removable block terminals with M3,5 screws; wire contacts are enclosed to prevent
Mounting	Quick install rail mounting EN 50022-35
Weight	450 g (0.99 lb.)

NOTE 1: Install arc suppression device across load to avoid module contact arcing and ensure specified relay life expectancy.

NOTE 2: Total operations = operations at power factor 1 multiplied by the limitation factor. if the power factor is 0.5 at 230 vac, 3A (1,000,000 operations), the limitation factor is 0.70. 1,000,000 x 0.70 = 700,000 total operations.

FIG 1. CONTACT LIFE FOR 100% RESISTIVE LOAD (typical) (note 1)

power factor = 1 (cos ϕ)

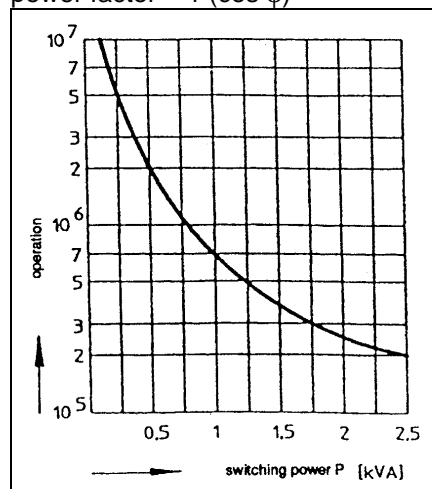
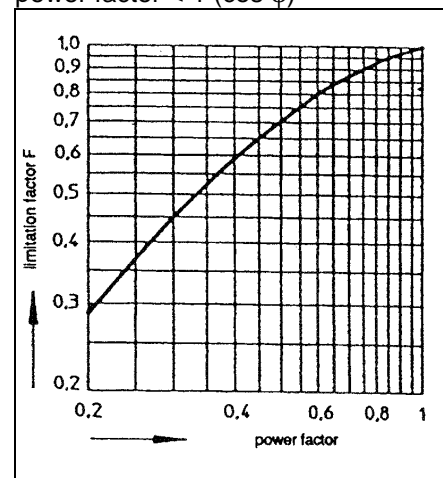

FIG 2. LIMITATION FACTOR FOR INDUCTIVE LOADS (note 2)

power factor < 1 (cos ϕ)



CAUTION

CONTACT DAMAGE

To ensure the 1 mA capability during the lifetime of the contact, NEVER exceed 300 mA and 60 V.

Failure to comply with these instructions will result in product damage.

FIG 3. QUADRATIC TOTAL CURRENT LIMIT

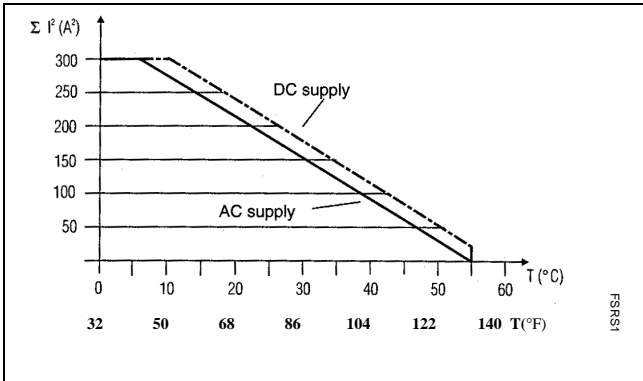

Figure 3. displays the maximal recommended external temperature versus the total load of all the safety module contacts. To use this curve, do the following:

- (1) Square the current in each contact branch, then sum all the results to obtain the vertical axis value.
- (2) Depending on what current is inside the safety module contacts (AC or DC), follow the horizontal line from the obtained value and note intersection of the appropriate curve.
- (3) Follow the intersection point down to determine the maximal recommended external temperature.

(Ex: $\Sigma I^2 = 200 \text{ A}^2$, AC current inside safety contacts, then $T = 22 \text{ °C}$ (72 °F).

If the module is located in a higher temperature environment, the lifetime of the electronic components may be reduced. Ventilation of the cabinet may be required.

MECHANICAL INSTALLATION

The FF-SRS5935 must be installed inside a NEMA 3 (IEC IP54) rating enclosure or better. The module can be clipped easily onto a 45mm width DIN rail (see figures 4 and 5 for installation and removal). Specific features of this product include removable block terminals. This feature provides easy access to wiring during installation and reduces machine downtime during maintenance.

FIG 4. MOUNTING DIMENSIONS (for reference only)

- a Width: 45 mm 1.77 in.
- b Height: 74 mm 2.91 in.
- c Depth: 121 mm 4.76 in.

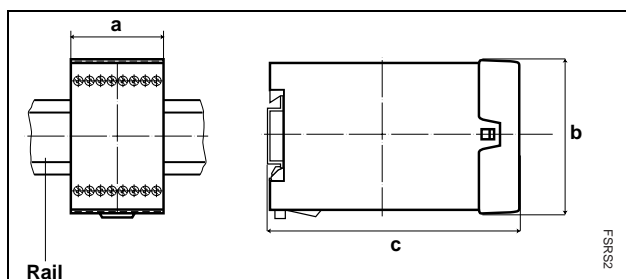

FIG 5. INSTALLATION DIAGRAM

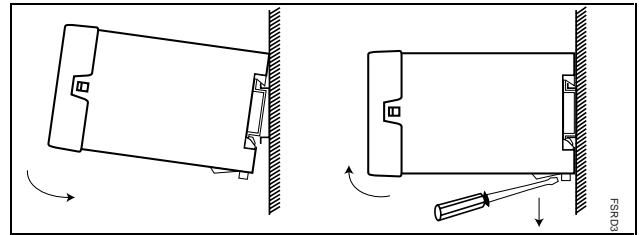
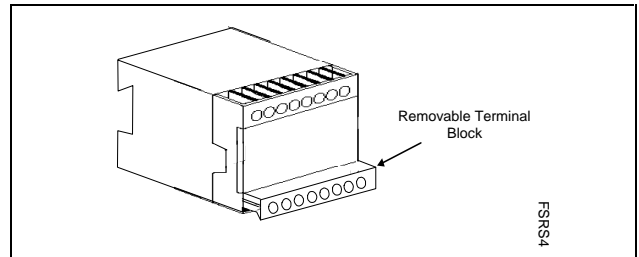

FIG 6. REMOVABLE TERMINAL BLOCKS



CONTROL RELIABILITY

“Control Reliability” means that “the device, system or interface shall be designed, constructed and installed such that a single component failure within the device, interface or system shall not prevent normal stopping action from taking place but shall prevent a successive machine cycle.” (ANSI B11.19-1990, 5.5)

OSHA 29 CFR 1910.217 states that “the control system shall be constructed so that a failure within the system does not prevent the normal stopping action from being applied to the press when required, but does prevent initiation of a successive stroke until the failure is corrected. The failure shall be detectable by a simple test, or indicated by the control system.”

Honeywell has developed new patented self-checking techniques which combine reliability with safety. The FF-SR Series safety control modules function with dual channel redundancy and positive self-checking monitoring. This means that a faulty component in our system will make the safety control modules fail in a safe mode.

This design meets the highest requirements (Category 4 as described in the EN 954 European norm). Category 4 safety control modules are designed and manufactured in such a way that a single breakdown or an accumulation of failures does not lead to the loss of the safety function when a dangerous situation arises. **The safety function is maintained on a permanent basis.**

MODE SETTING

⚠ WARNING

ELECTRICAL SHOCK

Remove power from FF-SR Series control modules and machine during installation and before setup.

Failure to comply with these instructions could result in death or serious injury.

To set the desired mode of operation, remove the front panel (see figure 7). Refer to the back of the front panel for switch setting options (see figure 8). Set switches as required, then replace front panel.

S1 AND S2 SWITCHES

Refer to the important warnings on page 6.

This module contains two internal switches (S1 and S2) that are used to set various modes of operation. This feature ensures application flexibility.

Switches S1 and S2 are used to select automatic start and manual start with or without cross fault detection.

Switch S1 is used to select an operating mode for **cross fault detection** between the two inputs. Cross fault monitoring must be used when two independent safety inputs are provided to this module to increase the overall safety level of the solution (see typical application examples).

Switch S2 is used to select **automatic start ("Autostart")** or **manual start ("Handstart")**. Terminals S33 and S34 must be connected for automatic start to function.

In either mode, if the safety device is actuated (emergency stop condition occurs), the normally open contact will open immediately and the normally closed contact will close. This emergency stop condition is relayed via the safety contacts of the module to the machine control circuitry to arrest dangerous motion and/or remove power.

FIG 7. FRONT PANEL REMOVAL

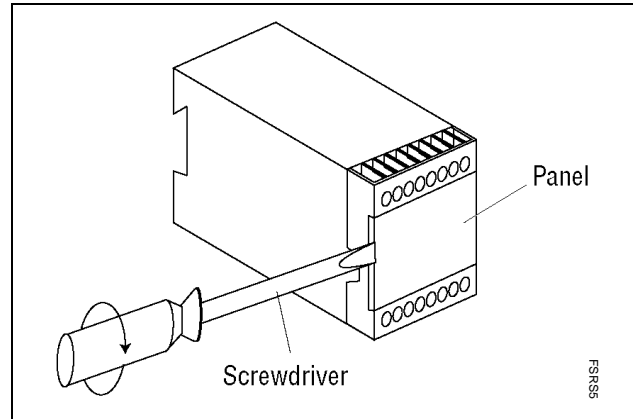

NOTICE

To gain access to the two internal switches, it is not necessary to remove the terminal blocks.

FIG 8. FRONT PANEL SWITCH SETTING DIAGRAM

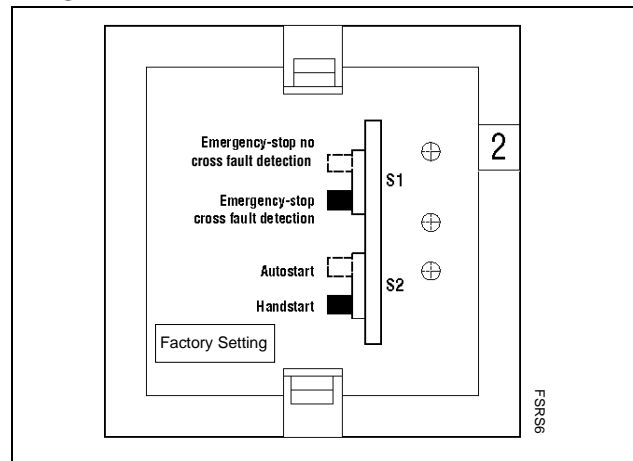

ELECTRICAL INSTALLATION

Multiple wiring configurations are possible for the FF-SRS5935 dual channel emergency stop module. General guidelines are provided because there are various ways to interface the module to machine control circuitry. **Refer to the important warnings (page 6)** and the application examples (pages 7 through 8).

CAUTION

SAFETY CONTROL MODULE DAMAGE

Do not supply any current/voltage to the FF-SRS5935 safety module control inputs. These inputs receive their voltage (24 vdc under a 35-50 mA current) from external power via pins A1 and A2. **Failure to comply with these instructions will result in product damage.**

FIG 9. BLOCK DIAGRAM

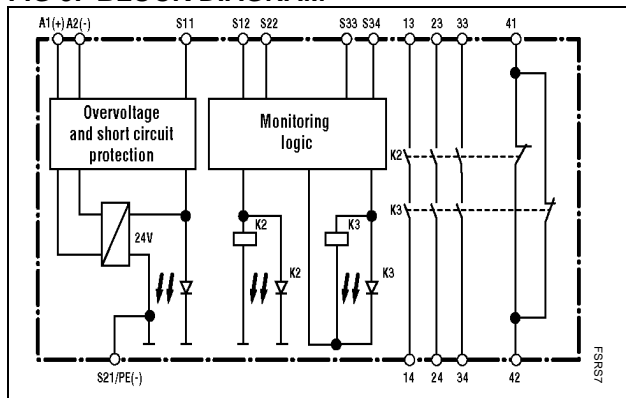

FUNCTIONAL DESCRIPTION

In the **manual start mode**, the module accepts input from the safety device (light curtain, safety mat, safety switches, etc.) between S11/S12 and S21/S22 after activation of the push button between S33 and S34; then, the normally open safety contacts (13/14, 23/24, 33/34) will close and the normally closed contact (41/42) will open.

In the **automatic start mode**, the module accepts immediate input from the safety device (light curtain, mat, safety switches, etc.) between S11/S12 and S21/S22 (S33 and S34 are jumpered if external relay monitoring is not needed); then, the normally open safety contacts (13/14, 23/24, 33/34) will close and the normally closed contact (41/42) will open.

In either mode, if the safety device is actuated (emergency stop condition occurs), the normally open contact will open immediately and the normally closed contact will close. This emergency stop condition is relayed via the safety contacts of the module to the machine control circuitry to arrest dangerous motion and/or remove power.

EXTENSION MODULES AND EXTERNAL CONTACTORS

One or more FF-SRE3081 Extension modules or external contactors with positively driven contacts can be used to multiply the number of contacts of the FF-SRS5935 Emergency Stop Module. If multiple safety contacts are used in parallel with one load, the maximum admissible current can be increased. For connection of the FF-SRE 3081 to the FF-SRS 5935 module, see the Installation Instructions for the FF-SRE 3081 Extension Module.

LED INDICATORS

The FF-SRS5935 module has three green LED status indicators (Power, K2 and K3) as illustrated below. The Power LED indicates power is applied to the safety control module. Illuminated K2 and/or K3 LED's indicate(s) that the corresponding internal safety relay is energized. Both K2 and K3 relays must be energized to have the normally open contacts 13/14, 23/24 and 33/34 in a closed condition. If one of the safety relays de-energizes, the normally closed contact will close (see Mode Setting, page 4, for additional information).

FIG 10. MODULE FRONT PANEL

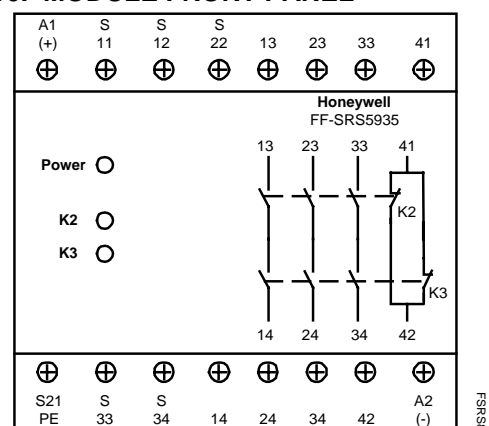
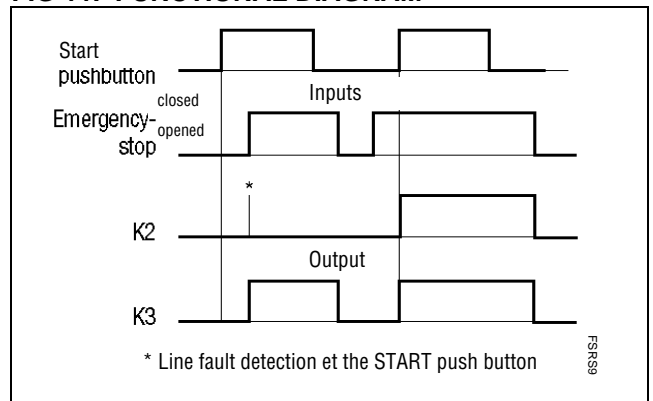

FIG 11. FUNCTIONAL DIAGRAM



If the start push button is closed before voltage is applied to S12 and S22 (also, if a line fault occurs via the start push button), the output contacts cannot be switched to START.

APPLICATION WARNINGS

WARNING

IMPROPER INPUT CONNECTIONS

- To ensure the highest level of safety, connect two safety device outputs into the input channel of the FF-SRS5935 safety module and always select the cross fault detection monitoring mode.
- If the safety device provides one safety output only (e.g., a switch driven by a direct acting mechanism like some GK, GSS, CLS or Emergency Stop push buttons), connect the FF-SRS5935 module as shown in the single input channel example. To avoid any short circuit possibilities on this single input channel, use conduit to protect the wiring and additional protection for the terminal strips inside the machine cabinets.

IMPROPER EMERGENCY STOP CONNECTION

- To ensure maximum safety, connect two normally closed contacts of the Emergency Stop into the input channel of the FF-SRS5935 module.

IMPROPER AUTOMATIC OPERATION MODE

- If the module is in the automatic operation mode, another part of the safety control circuitry must keep the latched function engaged.

IMPROPER PUSH BUTTON USE

- To ensure maximum safety when using an external start push button, always select manual start mode (handstart).
- Ensure the location of the manual restart function is outside of the danger zone and provides the operator with a clear view of the zone.
- For perimeter guarding solution, the operator should not be able to reach manual restart from the danger zone.
- A Programmable Logic Controller must NOT be able to override a manual restart function.

CONTACT WELDING

- Always protect all safety contacts with correctly rated fuses. These fuses must never exceed the rated FF-SRS5935 safety output capability to prevent contact welding.

IMPROPER EXTERNAL SAFETY RELAY MONITORING

- When using additional safety relays, always connect one normally closed contact of each relay in series inside the Final Switching Device (FSD) monitoring loop circuit (S33/S34). This connection will ensure correct operation of the external relays after each FF-SRS5935 activation.
- If the FF-SRS5935 is not activated often, the customer is responsible for accomplishing any additional test procedures of the external safety components. For instance, this testing can be done by removing the power from the FF-SRS5935 at machine power up every day.

IMPROPER ARC SUPPRESSOR INSTALLATION

- Never install an arc suppresser across the safety output contact of the safety control module.
- Always install arc suppressers across the coils of external safety relays.

IMPROPER SYSTEM SAFETY LEVEL

- Several safety components can be connected to a FF-SRS5935 control module. If more than one safety output is connected to one of the two input channels of the control module, always connect these safety outputs in series. Parallel wiring of multiple outputs into a single channel can defeat the channel and cause an unsafe condition.
- Individually activate and check all of the safety devices connected to a FF-SRS5935 control module to ensure proper operation.

IMPROPER EMERGENCY STOP PUSH BUTTON

- The Emergency Stop push button must be designed according to safety standards (US and European).
- Under any condition, the Emergency Stop switch must be able to open its contacts when activated.

IMPROPER SAFETY CONTROL MODULE OPERATION

- The cable resistance between S11/S12 and S21/S22 must be less than 68 Ω (ohms) for correct operation of the safety control module.
- A minimum of 21 Vdc must be present between each channel input (S11/S12 and S21/S22) to ensure the correct detection of sensor(s) output status.

LONGER RESPONSE TIME

- The FF-SRS5935 module will have a longer response time (when the emergency push button is activated) if the emergency stop push button is connected in series with the power supply of the module. However, connecting the emergency stop push button to the safety input channels will result in a shorter response time.

Failure to comply with these instructions could result in death or serious injury.

APPLICATION EXAMPLES

FIG 12. DUAL CHANNEL EMERGENCY STOP CIRCUITRY WITH MANUAL OR AUTOMATIC START, CROSS-FAULT MONITORING AND EXTERNAL CONTACTORS.

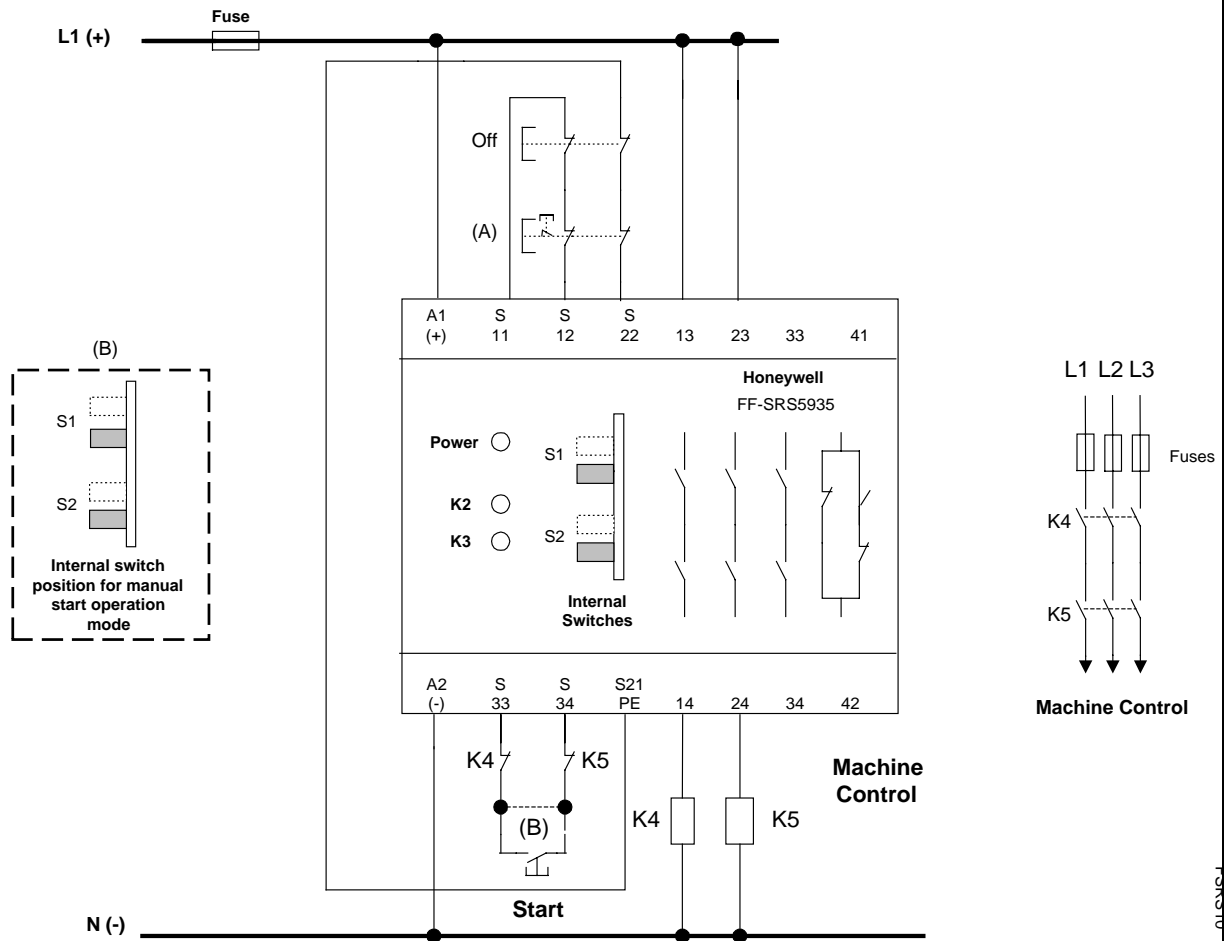

(A) This may be an emergency stop push button in series with dual output safety switching devices (OSSD) such as safety light curtains (FF-SB, FF-LS), safety mat (FF-SM), single beam (FF-SPS), modular safety light curtains (FF-SC), safety laser scanner (FF-SE), dual output safety limit or interlock switches (for example: CLS and GK).

(B) Manual start mode: Insert start push-button and select internal switch S2 as illustrated above

Automatic start mode: Insert shunt and select internal switch S2 to automatic start mode

This circuit has redundancy in the emergency-stop control circuit and therefore offers the highest possible safety level.

Manual start mode

1. After removing the stop condition, press and release the START push button to restart the safety control module.
2. The K2 and K3 LED's will turn ON indicating that the safety relays K2 and K3 are energized. The three normally open safety contacts will close and the normally closed safety contact will open allowing the machine to operate.

Automatic start mode

1. After removing the stop condition, the safety control module will immediately reset.
2. The K2 and K3 LED's will turn ON indicating that the safety relays K2 and K3 are energized. The three normally open safety contacts will close and the normally closed safety contact will open allowing the machine to operate.

External contactors:

With switching current >10 A, the output contacts should be reinforced by external contactors (K4 and K5) with positive-guided contacts. The proper operation of the external contactors is monitored by looping the NC contacts into the restart circuit (terminals S33-S34).

1. After activation of the E-stop push button, the two K2 and K3 LED's will turn OFF, indicating that the two internal safety relays K2 and K3 are de-energized. The normally open safety outputs 13/14, 23/24 and 33/34 will open and de-energize the external contactors K4 and K5. The normally closed safety output will also close.
2. After removing the stop condition, press and release the START push button to restart the safety control module. If the two contactors K4 and K5 are working properly, the K2 and K3 LED's will turn ON indicating that the safety relays K2 and K3 are energized. The three normally open safety contacts will close and the normally closed safety contacts will open allowing the machine to operate.

⚠ WARNING

IMPROPER EXTERNAL SAFETY RELAYS PERFORMANCE

- Use two independent stop circuit safety relays with mechanically linked contacts to reliably detect a welded contact.

APPLICATION EXAMPLES (continued)

FIG 13. SINGLE CHANNEL EMERGENCY STOP CIRCUITRY WITH MANUAL START.

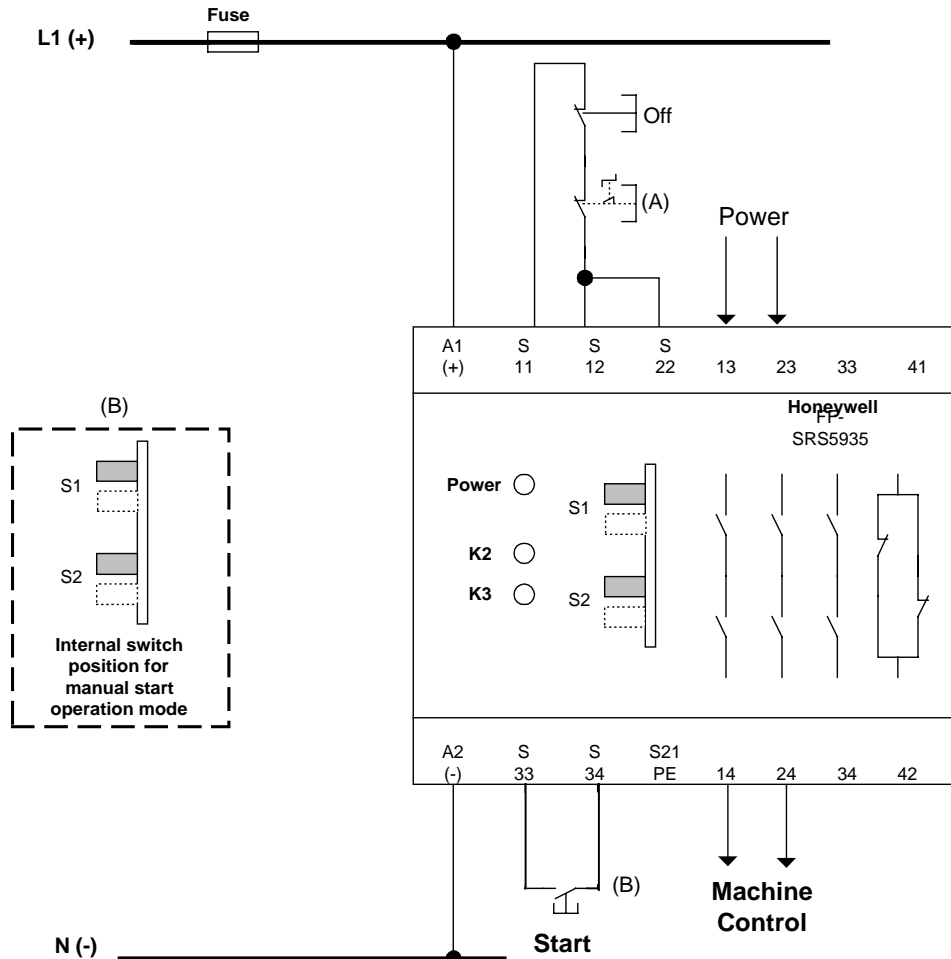

(A) This may be an emergency stop push button with a single output safety device in series such as - safety limit or interlock switches (for example: CLS, GK and GSS).

(B) Automatic start mode: Insert a shunt and select internal switch S2 to automatic start mode

This circuit has NO redundancy in the emergency-stop control circuit and therefore offers a minor safety level.

NOTICE

- If using a single safety input, position the S1 switch to the “no cross-fault monitoring” mode to remove the cross fault monitoring feature.
- If a safety control module is used in an automatic start mode, position the S2 switch to the “automatic start” mode. In addition, the start push button must be replaced by a jumper (between terminals S33/S34). If external safety relay monitoring is necessary, connect one contact of each relay required to be monitored, in series between S33/S34.

⚠ WARNING

IMPROPER AUTOMATIC START MODE

- If the module is in the automatic operation mode, another part of the safety control circuitry must keep the latched function engaged.

Failure to comply with these instructions could result in death or serious injury.

IMPORTANT NOTICES

NOTICE

- The FF-SRS5935 will only restart after the two input channels have been opened and then closed (an activation). There is no timing limitation between the activations of these two safety inputs.
- In the manual start mode, closing the start push button will immediately close the normally open contacts of the safety control module and initiate a machine start cycle. The push button must be released before the next start cycle is allowed. This will prevent automatic restart in case the push button is broken in the closed position.
- If a safety control module is used in an automatic start mode, position the S2 switch to the "automatic start" mode. In addition, the start push button must be replaced by a jumper (between terminals S33/S34). If external safety relay monitoring is necessary, connect one contact of each relay required to be monitored, in series between S33/S34.

FF-SRS5935 TROUBLESHOOTING FLOW DIAGRAM (PAGE 1 OF 3)

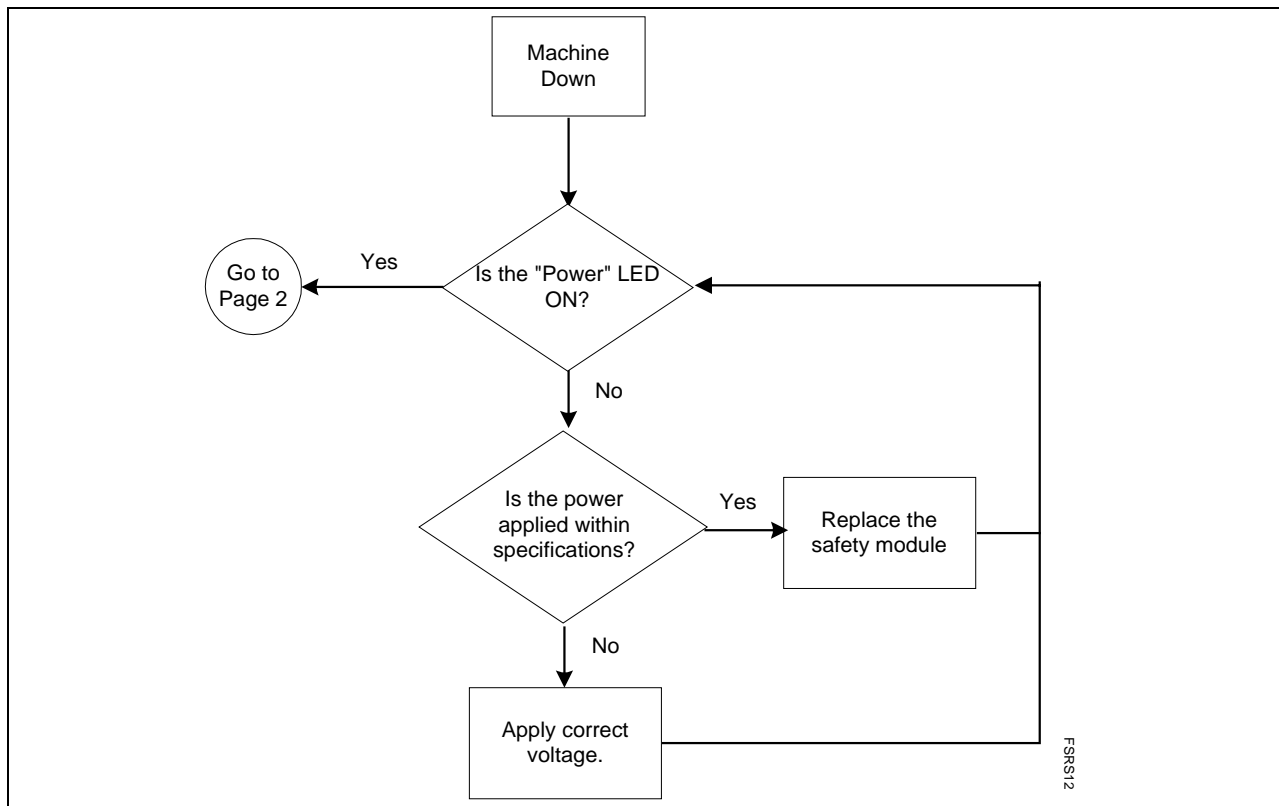

FF-SRS5935 TROUBLESHOOTING FLOW DIAGRAM (PAGE 2 OF 3)

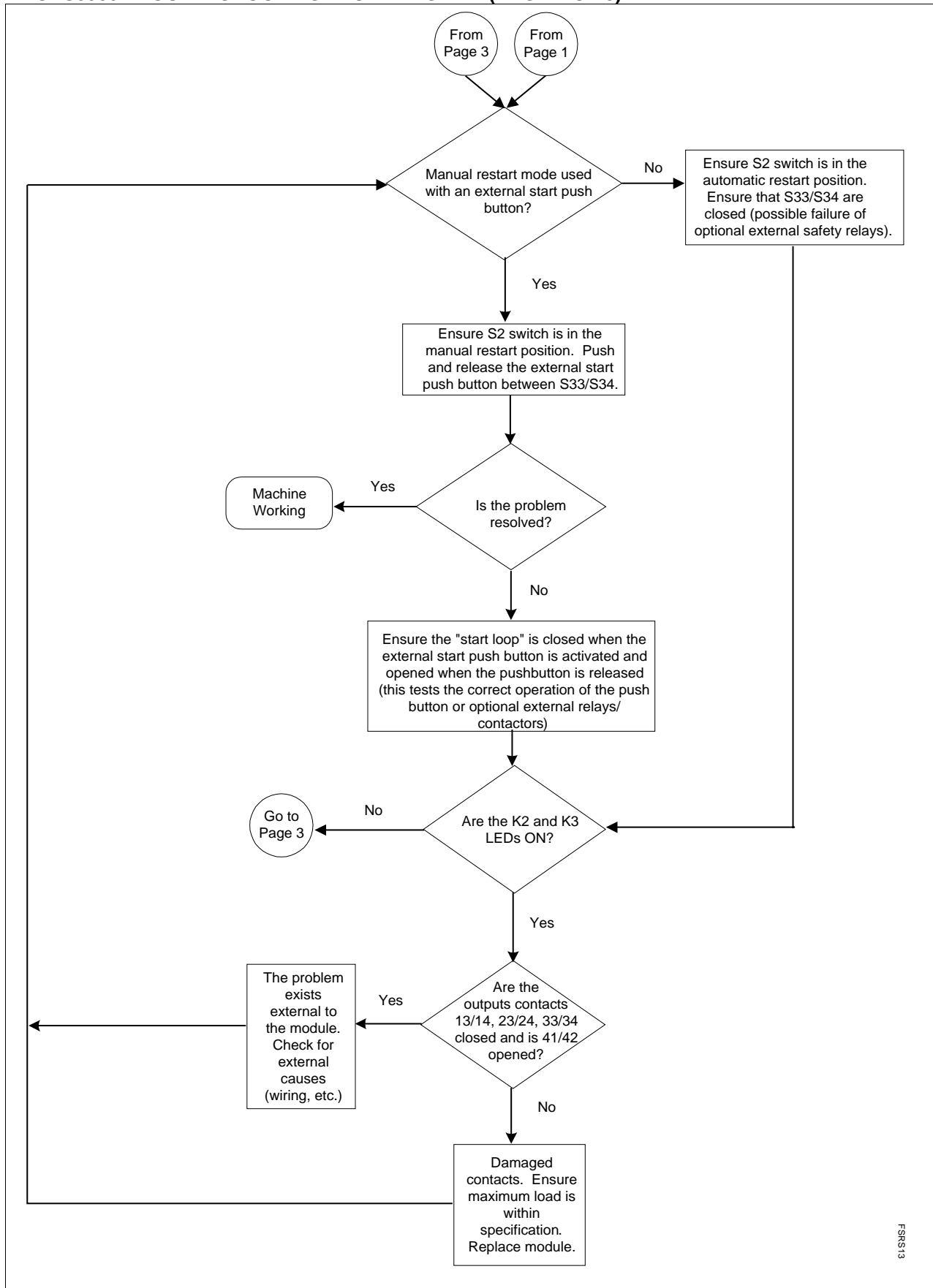

FR13

FF-SRS5935 TROUBLESHOOTING FLOW DIAGRAM (PAGE 3 OF 3)

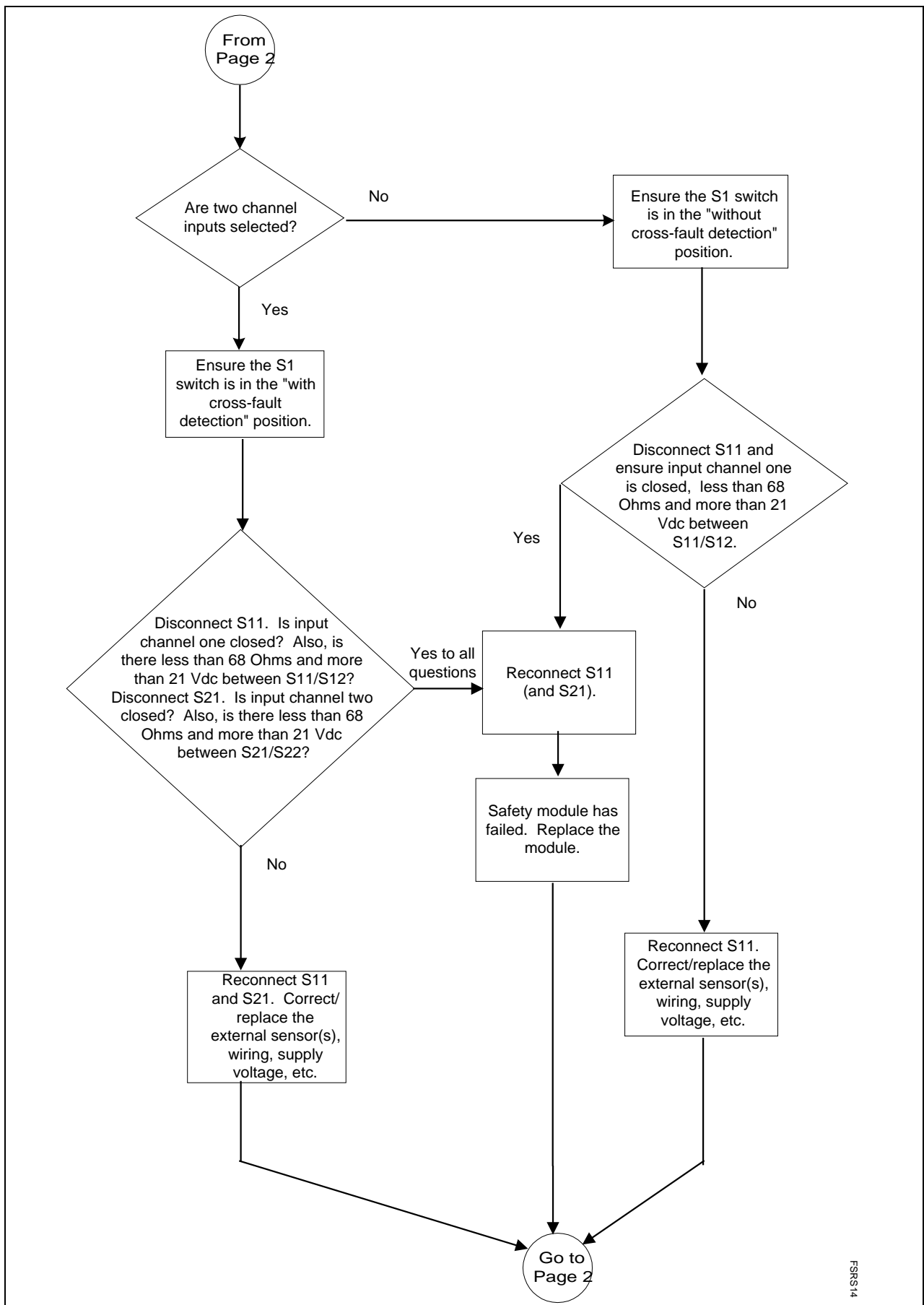

FRRS14

WARRANTY AND REMEDY

Honeywell warrants goods of its manufacture as being free of defective materials and faulty workmanship. Contact your local sales office for warranty information. If warranted goods are returned to Honeywell during the period of coverage, Honeywell will repair or replace without charge those items it finds defective. The foregoing is Buyer's sole remedy and is **in lieu of all other warranties, expressed or implied, including those of merchantability and fitness for a particular purpose.**

While we provide application assistance, personally and through our literature, it is up to the customer to determine the suitability of the product in the application.

Specifications may change at any time without notice. The information we supply is believed to be accurate and reliable as of this printing. However, we assume no responsibility for its use.

SALES AND SERVICE

For application assistance, current specifications, pricing or name of the nearest Authorized Distributor, contact a nearby sales office or call:

TELEPHONE

+ 61 (0) 2 9370 4303 Australia
1-800-737-3360 Canada
+ 33 (0) 1 60 19 80 41 France
+ 49 (0) 69 8064 444 Germany
34 91 313 61 00 Spain
1-815-235-6847 International
+ 44 (0) 161 251 4079 UK
1-800-537-6945 USA

FAX

+ 61 (0) 2 9353 7406 Australia
1-800-565-4130 Canada
+ (33) 76 41 72 56 France
+ 49 (0) 69 8064 442 Germany
34 91 313 61 29 Spain
+ 44 (0) 161 251 4141 UK
1-815-235-6545 USA

INTERNET

<http://www.honeywell.com/sensing/>
info@micro.honeywell.com

ORDER GUIDE

FF-SRS5935

Voltage:

2 = 24 V DC

E = 120 V AC

G = 230 V AC