

SIEMENS

SIMATIC

ET 200L Distributed I/O Device

Manual

Preface, Contents	1
Product Overview	2
Installation	3
Wiring	4
Commissioning	5
Diagnostics	6
General Technical Data	7
Terminal Blocks and Supplementary Terminals – Technical Data	8
ET 200L Electronics Blocks – Technical Data	8
Order Numbers	A
Type and Device Master Files	B
ESD	C
Glossary, Index	

Safety Guidelines

This manual contains notices you have to observe in order to ensure your personal safety, as well as to prevent damage to property. The notices referring to your personal safety are highlighted in the manual by a safety alert symbol, notices referring to property damage only have no safety alert symbol. The notices shown below are graded according to the degree of danger.



Danger

indicates that death or severe personal injury will result if proper precautions are not taken.



Warning

indicates that death or severe personal injury may result if proper precautions are not taken.



Caution

with a safety alert symbol indicates that minor personal injury can result if proper precautions are not taken.

Caution

without a safety alert symbol indicates that property damage can result if proper precautions are not taken.

Notice

indicates that an unintended result or situation can occur if the corresponding notice is not taken into account.

If more than one degree of danger is present, the warning notice representing the highest degree of danger will be used. A notice warning of injury to persons with a safety alert symbol may also include a warning relating to property damage.

Qualified Personnel

The device/system may only be set up and used in conjunction with this documentation. Commissioning and operation of a device/system may only be performed by qualified personnel. Within the context of the safety notices in this documentation qualified persons are defined as persons who are authorized to commission, ground and label devices, systems and circuits in accordance with established safety practices and standards.

Prescribed Usage

Note the following:



Warning

This device and its components may only be used for the applications described in the catalog or the technical description, and only in connection with devices or components from other manufacturers which have been approved or recommended by Siemens.

Correct, reliable operation of the product requires proper transport, storage, positioning and assembly as well as careful operation and maintenance.

Trademarks

All names identified by ® are registered trademarks of the Siemens AG.

The remaining trademarks in this publication may be trademarks whose use by third parties for their own purposes could violate the rights of the owner.

Disclaim of Liability

We have reviewed the contents of this publication to ensure consistency with the hardware and software described. Since variance cannot be precluded entirely, we cannot guarantee full consistency. However, the information in this publication is reviewed regularly and any necessary corrections are included in subsequent editions.

Preface

Purpose of the Manual	The information provided in this manual enables you to operate the distributed I/O.
Basic knowledge required	To understand the manual, you require general experience in the field of automation engineering.
Scope of this manual	<p>This manual is applicable to the components of the ET 200L distributed I/O system.</p> <p>This manual contains a description of the components which were valid at the time the manual was published. We reserve the right to issue a Product Information which contains up-to-date information about new components and new versions of components.</p>
Changes Since the Previous Manual	<p>Changes have been made since the previous version of this manual, order number 6ES7 130-1AA00-8AA0, Release 4, as regards the following:</p> <ul style="list-style-type: none">• Proclamation the ET 200L-SC IM-SC• Proclamation the Smart Connect SC
Guide	<p>The manual's navigation features outlined below support quick access to specific information:</p> <ul style="list-style-type: none">• The manual begins with a table of contents and a list of tables.• Important terms are explained in the glossary.• Navigate to the most important topics in our documents using the index.
Special notes	In addition to this manual, you also need the manual of the DP master you are using.
Recycling and Disposal	The ET 200L distributed I/O device can be recycled due to its ecologically compatible equipment. For environmentally compliant recycling and disposal of your electronic waste, please contact a company certified for the disposal of electronic waste.

Further support

If you have any questions relating to the products described in this manual, and do not find the answers in this documentation, please contact your Siemens partner at our local offices.

<http://www.ad.siemens.de>

The portal to our technical documentation for the various SIMATIC products and systems is available at:

<http://www.siemens.de/simatic-tech-doku-portal>

The online catalog and ordering system are available at:

<http://mall.ad.siemens.com>

Training center

Siemens offers various courses to get you started with the ET 200L distributed I/O and the SIMATIC S7 automation system. Please contact your regional Training Center, or the central Training Center in D-90327 Nuremberg.

Phone: + 49 (911) 895-3200

<http://www.sitrain.com>

Technical Support

You can reach technical support for all A&D projects

- Using the Support Request form on the web:
<http://www.siemens.de/automation/support-request>
- Phone: + 49 180 5050 222
- Fax: + 49 180 5050 223

For further information about our technical support, refer to the Internet at

<http://www.siemens.com/automation/service>

Service & Support on the Internet

In addition to our documentation services, you can also make use of our comprehensive online knowledge base on the Internet.

<http://www.siemens.com/automation/service&support>

There you will find:

- our Newsletter, which constantly provides you with the latest information about your products.
- the right documentation for you using our Service & Support search engine.
- the bulletin board, a worldwide knowledge exchange for users and experts.
- your local contact for Automation & Drives in our contact database.
- Information about on-site services, repairs, spare parts. Lots more is available on our “Service” pages.

Contents

	Preface	iii
1	Product Overview	1-1
1.1	What Is the ET 200 Distributed I/O System?	1-2
1.2	What Is the ET 200L Distributed I/O Device?	1-3
1.2.1	What Is the ET 200L Block I/O Device?	1-6
2	Installation	2-1
2.1	Installing the ET 200L TB 16L/TB 32L Terminal Block and Supplementary Terminal	2-2
2.2	Installing and Disassembling the ET 200L Electronics Block	2-5
2.3	Setting the ET 200L PROFIBUS Address	2-6
3	Wiring	3-1
3.1	General Rules and Regulations	3-2
3.2	Configuring the Electrical Installation	3-4
3.3	Wiring Rules	3-8
3.4	Wiring the ET 200L TB 16L/TB 32L Terminal Block	3-10
4	Commissioning	4-1
4.1	Configuration Software	4-1
4.2	Commissioning the ET 200L	4-2
5	Diagnostics	5-1
5.1	Diagnostics Using the LEDs	5-2
5.2	Slave Diagnostics	5-3
5.2.1	Structure of the Slave Diagnosis	5-4
5.2.2	Structure of Station Statuses 1 to 3, Master Station Number and Manufacturer Identification	5-5
6	General Technical Data	6-1
6.1	Standards and Certification	6-2
6.2	Electromagnetic Compatibility	6-4
6.3	Shipping and Storage Conditions	6-6
6.4	Mechanical and Climatic Environmental Conditions	6-7
6.5	Details of Insulation Testing, Safety Class, and Degree of Protection ...	6-8
6.6	Rated Voltage of the ET 200L Distributed I/O Device	6-9

7	Terminal Blocks and Supplementary Terminals – Technical Data	7-1
7.1	Terminal Block TB 16L – 6ES7 193-1CH00-0XA0, 6ES7 193-1CH10-0XA0	7-2
7.2	Terminal Block TB 32L – 6ES7 193-1CL00-0XA0, 6ES7 193-1CL10-0XA0	7-4
7.3	Supplementary Terminals for the TB 16L and TB 32L	7-7
8	ET 200L Electronics Blocks – Technical Data	8-1
8.1	Electronics Block L 16 DI DC 24 V – 6ES7131-1BH01-0XB0	8-2
8.2	Electronics Block L 16 DO DC 24 V/0.5 A – 6ES7132-1BH00-0XB0	8-5
8.3	Electronics Block L 32 DI DC 24 V 6ES7131-1BL01-0XB0	8-8
8.4	Electronics Block L 32 DO DC 24 V/0.5 A –6ES7132-1BL00-0XB0	8-11
8.5	Electronics Block L 16 DI/16 DO DC 24 V/0.5 A – 6ES7133-1BL01-0XB0	8-14
A	Order Numbers	A-1
A.1	Order Numbers for ET 200L Components	A-2
A.2	Order Numbers for PROFIBUS Accessories	A-5
B	Type and Device Master Files	B-1
C	Guidelines for Handling Electrostatically Sensitive Devices (ESD)	C-1
C.1	What is ESD?	C-2
C.2	Electrostatic Charging of Persons	C-3
C.3	General Protective Measures Against Electrostatic Discharge Damage	C-4
	Glossary	Glossary-1
	Index	Index-1

Figures

1-1	A Typical PROFIBUS-DP Installation	1-2
1-2	View of the ET 200L Distributed I/O Device	1-6
2-1	Installing the Terminal Block	2-3
2-2	Disassembling the Terminal Block	2-4
2-3	Installing the Electronics Block	2-5
3-1	Operating the ET 200L from a Grounded Supply	3-6
3-2	How the Spring Terminal Works	3-9
3-3	Terminal Connections on Terminal Block TB 16L	3-10
3-4	Alternative Ways of Connecting the Voltage Supply	3-11
5-1	Structure of the Slave Diagnosis	5-4
7-1	The TB 16L Terminal Block with the Electronics Block Clipped On, Dimension Drawing	7-2
7-2	The TB 32L Terminal Block with the Electronics Block Clipped On, Dimension Drawing	7-5
7-3	TB 16L/TB 32L Supplementary Terminals, Dimension Drawing	7-8
8-1	View of the L 16 DI DC 24 V Electronics Block	8-2
8-2	Block Diagram of the L 16 DI DC 24 V Electronics Block	8-3
8-3	View of the L 16 DO DC 24 V/0.5 A Electronics Block	8-5
8-4	Block diagram of the L 16 DO DC 24 V/0.5 A Electronics Block	8-6
8-5	View of the L 32 DI DC 24 V Electronics Block	8-8
8-6	Block diagram of the L 32 DI DC 24 V Electronics Block	8-9
8-7	View of the L 32 DO Electronics Block DC 24 V/0.5 A	8-11
8-8	Block Diagram of the L 32 DO DC 24 V/0.5 A Electronics Block	8-12
8-9	View of the L 16 DI/16 DO DC 24 V/0.5 A Electronics Block	8-14
8-10	Block Diagram of the L 16 DI/16 DO DC 24 V/0.5 A Electronics Block	8-15
A-1	Labeling Strips 6ES7193-1BH00-0XA0	A-3
A-2	Labeling Strips 6ES7193-1BL00-0XA0	A-4
C-1	Electrostatic Voltages which can Build up on a Person	C-3

Tables

1-1	General Components for the ET 200L	1-4
1-2	Components of the ET 200L Distributed I/O Device	1-7
3-1	DIN VDE Regulations for Installation of a Controller	3-4
3-2	Pinout of the PROFIBUS-DP Terminal Connection	3-8
3-3	Pinout of the PROFIBUS-DP Terminal Connection	3-12
5-1	Diagnostics Using the LED Display	5-2
5-2	Function Blocks for Slave Diagnosis	5-4
5-3	Structure of Station Status 1 (Byte 0)	5-5
5-4	Structure of Station Status 2 (Byte 1)	5-6
6-1	Rated Voltage of the ET 200L Distributed I/O Device	6-9
7-1	Pinout of the TB 16L Terminal Block	7-3
7-2	Pinout of the TB 32L Terminal Block	7-6
7-3	Supplied Versions of the Supplementary Terminals	7-7
8-1	Assignment of the ET 200L Electronic Blocks to the Terminal Blocks ..	8-1
A-1	Terminal Block Order Numbers	A-2
A-2	Electronics Block Order Numbers	A-2
A-3	Supplementary Terminal Order Numbers	A-2
A-4	Accessories for the ET 200 Distributed I/O Device	A-5
A-5	Manuals for STEP 7 and SIMATIC S7	A-6
A-6	Manuals for ET 200 on SIMATIC S5	A-6
B-1	Version der Projektier-Software	B-2
B-2	Data for PROFIBUS-DP	B-3
B-3	Maximum Number of Inputs and Outputs with the ET 200L	B-4
B-4	DP Identifiers for the ET 200L	B-4

Product Overview

1

In This Chapter

The product overview provides information about

- The role of the ET 200L distributed I/O device within the ET 200 distributed I/O system.
- The components which make up the ET 200L distributed I/O device.

Contents of the Chapter

Section	Subject	Page
1.1	What Is the ET 200 Distributed I/O System?	1-2
1.2	What Is the ET 200L Distributed I/O Device?	1-3

1.1 What Is the ET 200 Distributed I/O System?

What Is the ET 200?

When a system is installed, the input/output modules are normally installed centrally in the programmable logic controller.

If inputs and outputs are made at long distances from the programmable logic controller, there may be long runs of cabling which are not immediately comprehensible, and electromagnetic interference may impair reliability.

In such systems, we recommend you to use the ET 200 distributed I/O system:

- The controller CPU is located centrally.
- The I/O (input/output) system operates locally in a distributed fashion.
- The ET 200 high-performance bus system ensures that the CPU and I/O system communicate with each other without problems owing to its high data transfer rates.

What Does the ET 200 Consist Of?

The ET 200 distributed I/O system consists of active (master) and passive (slave) nodes that are interconnected via the PROFIBUS-DP.

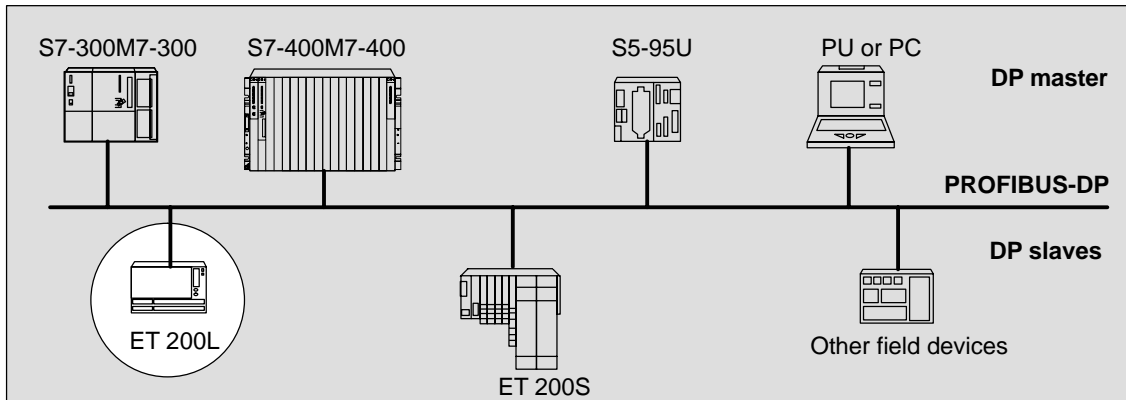

Figure 1-1 A Typical PROFIBUS-DP Installation

PROFIBUS-DP

PROFIBUS-DP (DP means distributed I/O) is an open bus system conforming with *IEC 61784-1:2002 Ed1 CP 3/1*. The PROFIBUS-DP consists of a DP master and DP slaves.

- **DP master:** The link between the controller and the distributed I/O system is the DP master. The DP master exchanges data with the distributed I/O system over the PROFIBUS-DP and monitors the field bus.
- **DP slave:** The I/O devices are connected as DP slaves. DP slaves process data locally from the sensors and signal control elements in such a manner that they can be transferred over the PROFIBUS-DP field bus.

1.2 What Is the ET 200L Distributed I/O Device?

Definition The ET 200L distributed I/O device is a DP slave within the ET 200 distributed I/O system, its degree of protection being IP 20.

Applications Owing to its compact and flat design, the ET 200L distributed I/O device is particularly suitable for applications in which space is at a premium. The ET 200L distributed I/O device has been designed for the low-end to medium performance ranges.

ET 200L Block I/O Device The ET 200L block I/O device is not expandable. The ET 200L consists of a terminal block for the wiring, to which an electronics block is connected. The electronics block determines the number of input/output channels.

The ET 200L block I/O device is available with 16 or 32 channels.

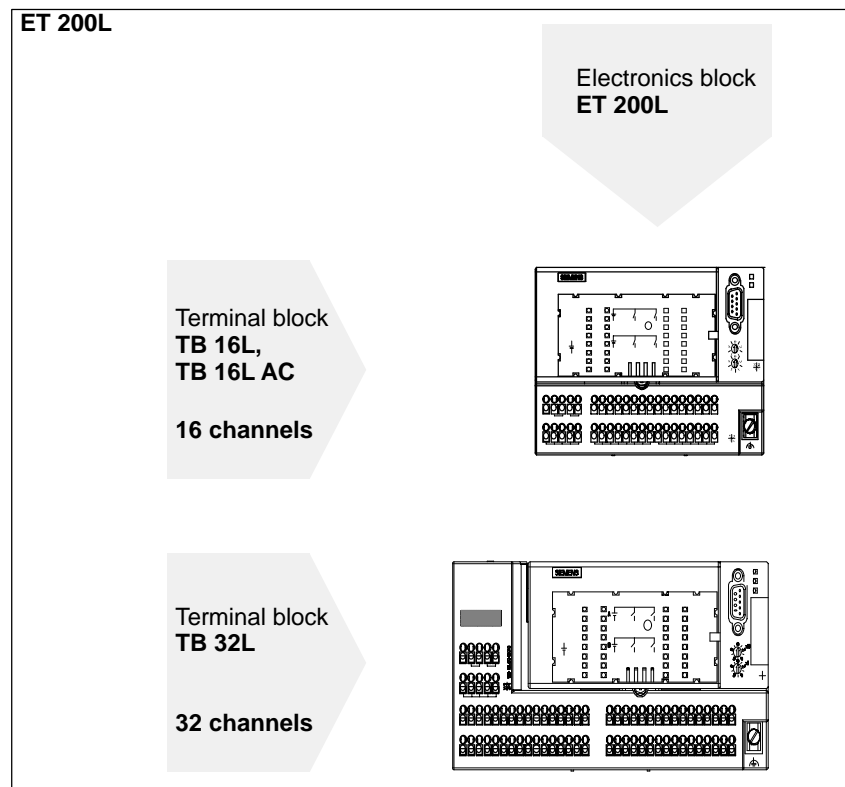



General Components for the ET 200L

A range of components are available for setting up the ET 200L. You will find the components that you require for all versions of the ET 200L in Table 1-1.

You will find other components in Section 1.2.1.

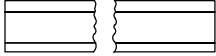
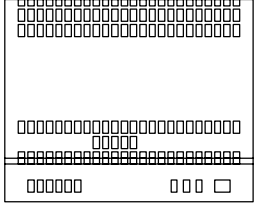
Table 1-1 General Components for the ET 200L

Component	Function	Illustration
Rail (EN 50022, 35 × 15 or 35 × 7.5)	... is the mounting rack for the ET 200L.	
Power supply (PS)	<p>... converts the mains voltage (120/230 VAC) into a 24 V DC operating voltage for supplying the ET 200L.</p> <p>... is the load current power supply for the 24 V DC load circuits.</p>	
PROFIBUS cables with bus connector	... interconnect the nodes of a PROFIBUS-DP installation.	

Terminal Block

The terminal block (TB) is used for mounting the electronics block (EB). It contains the wiring so that if the electronics block is replaced, leads do not have to be loosened.

The terminal block is characterized by the following:

- It can be pre-wired before the electronics block is mounted.
- Depending on the design, wiring can be connected by means of screw-type or spring terminals.
- It has a two-wire termination and can be upgraded to a three- or four-wire termination by using supplementary terminals.
- It does not contain any active electronic components. The terminal block cannot therefore be destroyed electrically.
- You can insert different electronics blocks.
- There are 16-channel (TB 16L) and 32-channel (TB 32L) terminal blocks.

Electronics Block

The electronics block contains the logic circuitry and is inserted into the terminal block and screwed. It is characterized by the following:

- It defines the number of input/output channels.
- You do not have to loosen the terminal lead to replace the electronics block; you merely have to remove the bus connector.
- The PROFIBUS-DP is connected via a bus connector to the electronics block.
- You can set PROFIBUS addresses 1 to 99.
- There is galvanic isolation between the PROFIBUS-DP and the internal electronics.
- LEDs are used to display: The voltage supply of the electronics block (ON), bus faults (BF), group errors (SF; not for ET 200L), the status of inputs and outputs
- There is a labeling strip in the electronics block for clear identification of inputs and outputs. You can order the labeling strip separately (refer to Appendix A.1).
- A circuit diagram is displayed on the electronics block. The circuit diagram is located beneath the labeling strip.

Processing Time

The internal processing time is $< 1\text{ms}$.

1.2.1 What Is the ET 200L Block I/O Device?

Features of the ET 200L

Figure 1-2 shows you a view of the ET 200L distributed I/O device. It consists of a terminal block and an electronics block.

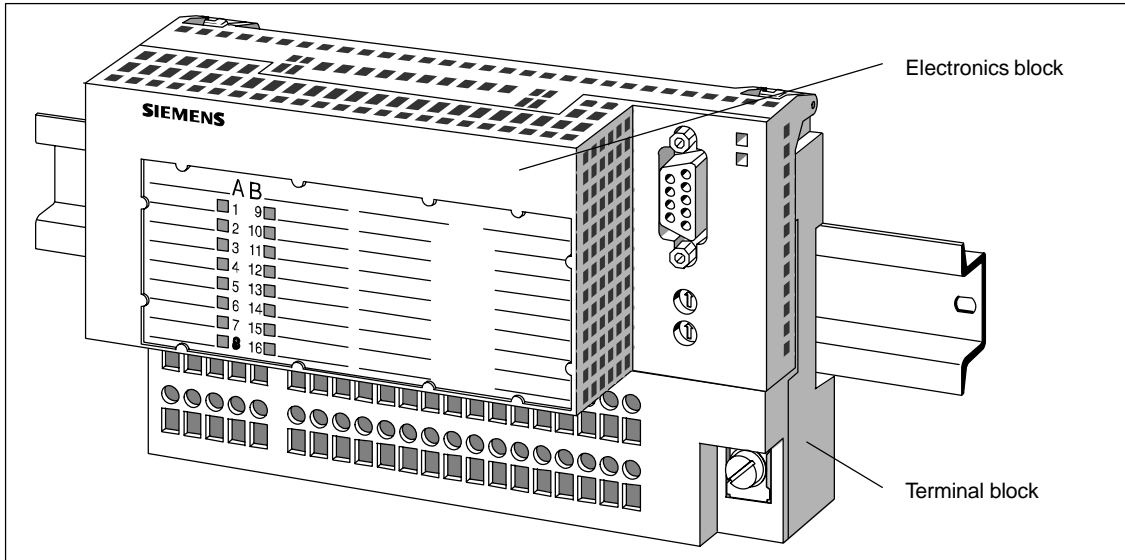

Figure 1-2 View of the ET 200L Distributed I/O Device

ET 200L Modules

The modules incorporated in the ET 200L include:

- 24 V DC digital input and/or output modules

ET 200L Components

A whole range of components is available for installing and commissioning the ET 200L. The most important components and their functions are listed in Table 1-2:

Table 1-2 Components of the ET 200L Distributed I/O Device

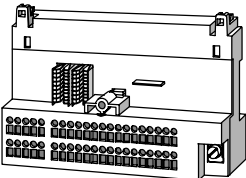
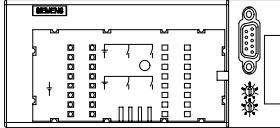
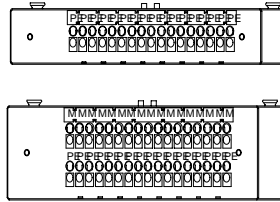
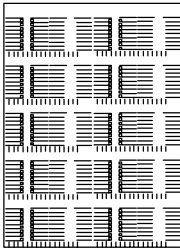
Component	Function	Illustration
TB 16L, TB 32L terminal block	... carries the wiring and accepts the electronics block.	
Electronics block	... is mounted on the terminal block. It defines the function (input or output).	
Supplementary terminals <ul style="list-style-type: none"> - 1-row - 2-row 	... are an extension for actuators and sensors with a 3- or 4-wire termination.	
Labeling sheet	... allows the labeling strips to be labeled automatically or printed using a laser printer.	

Technical Data

You will find the technical data for the terminal blocks in Sections 7.1 to 7.2 and the technical data for the electronics blocks in Chapter 8.

Installation

2

Introduction

The ET 200L distributed I/O device has been designed for simple installation and wiring. To this end, the label of the ET 200L distributed I/O device has been made self-explanatory.

In this chapter, you will find additional information on installing and wiring the ET 200L distributed I/O device.

Procedure

A number of steps are involved in the installation of the ET 200L distributed I/O device. We suggest you adhere to the following sequence:

Procedure		Section
Installing the ET 200L	1. Install the ET 200L TB 16L/TB 32L terminal block and supplementary terminal	2.1
	2. Install and disassemble the ET 200L electronics block	2.2
	3. Set the ET 200L PROFIBUS address	2.3

Contents of the Chapter

Section	Topic	Page
2.1	Installing the ET 200L TB 16L/TB 32L Terminal Block and Supplementary Terminal	2-2
2.2	Installing and Disassembling the ET 200L Electronics Block	2-5
2.3	Setting the ET 200L PROFIBUS Address	2-6

2.1 Installing the ET 200L TB 16L/TB 32L Terminal Block and Supplementary Terminal

Introduction

In this section, we describe how you install the terminal block and the supplementary terminal.

Requirements

Install the terminal block on a rail.

- You install the ET 200L distributed I/O device on a rail conforming with EN 50022 (35 × 7.5 or 35 × 15).
- The preferred mounting position is horizontal installation on a vertical wall. All other mounting positions are conceivable.
- You require a free space on a rail of 145 mm (16 channels) or 191 mm (32 channels).
- The minimum installation depth is 82 mm (with an electronics block installed and an MLFB 6ES7 972-0CA30 0XA0 bus connector connected) when using a 35 × 7,5 mm rail.
- You require a free space of 35 mm above the terminal block. You require a free space of 20 mm below the terminal block (when using the 42 mm single-tier supplementary terminal or the 57 mm two-tier supplementary terminal).

Installing the Terminal Block

Install the terminal block in the following order:

1. Mount the terminal block on the rail.
2. Tilt the terminal block backwards until you hear both the safety bolts engage.

You can now wire the terminal block (refer to Chapter 3) before you install the electronics block. If you are using supplementary terminals, you must install them before you commence wiring.

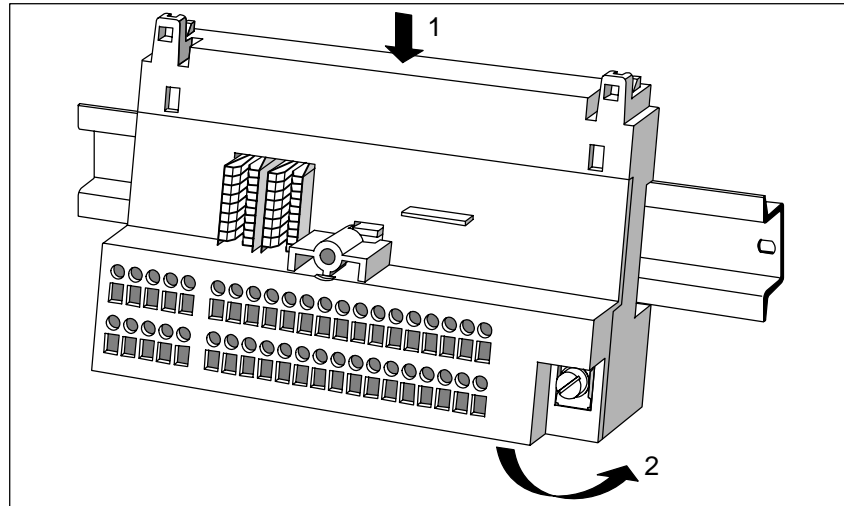

Figure 2-1 Installing the Terminal Block

Installing and Disassembling Supplementary Terminals

Push the supplementary terminals into the existing guideways on the lower side of the terminal block until you hear the safety bolt engage.

To disassemble supplementary terminals, proceed as follows:

1. Pull the safety bolt downwards as far as the stop.
2. Pull out the supplementary terminals forwards from the guideways.

Disassembling the Terminal Block

Remove the terminal block in the following order (refer also to Figure 2-2):

1. Turn off the power supply.
2. Remove the electronics block.
 - Remove the bus connector.
 - Loosen the fixing screw.
 - Tilt the electronics block forwards.
3. Loosen the wiring.
4. If you are using supplementary terminals, you must remove them before disassembling the terminal block (see above).
5. Press the two safety bolts downwards in succession with a screwdriver.
6. Tilt and remove the terminal block from the rail.

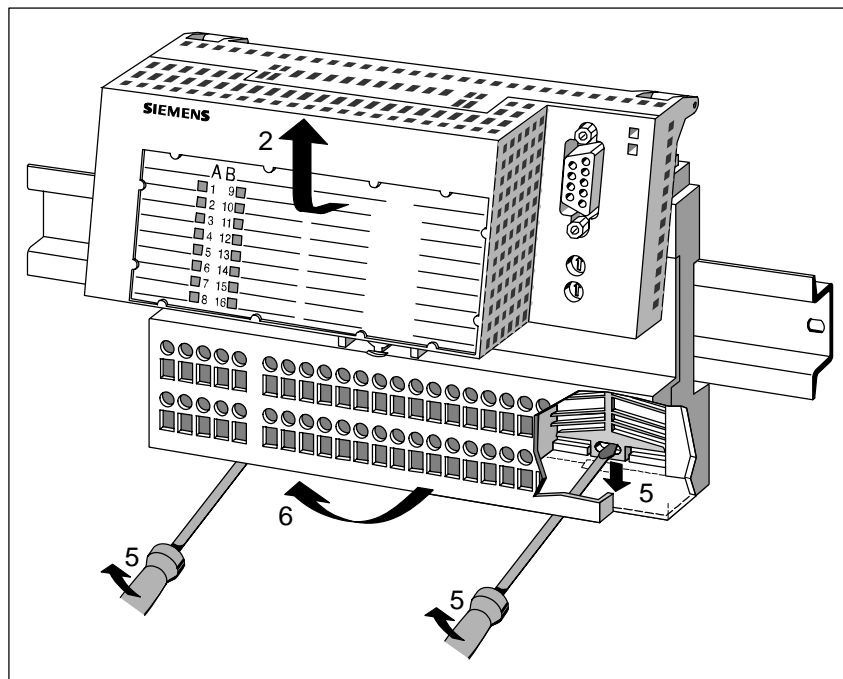

Figure 2-2 Disassembling the Terminal Block

2.2 Installing and Disassembling the ET 200L Electronics Block

Installing the Electronics Block

Attach the electronics block to the terminal block in the following order:

1. Insert the electronics block from above into the guideways on the terminal block.
2. Tilt the electronics block backwards as far as the stop.
3. Secure the electronics block on the terminal block by tightening the screw:

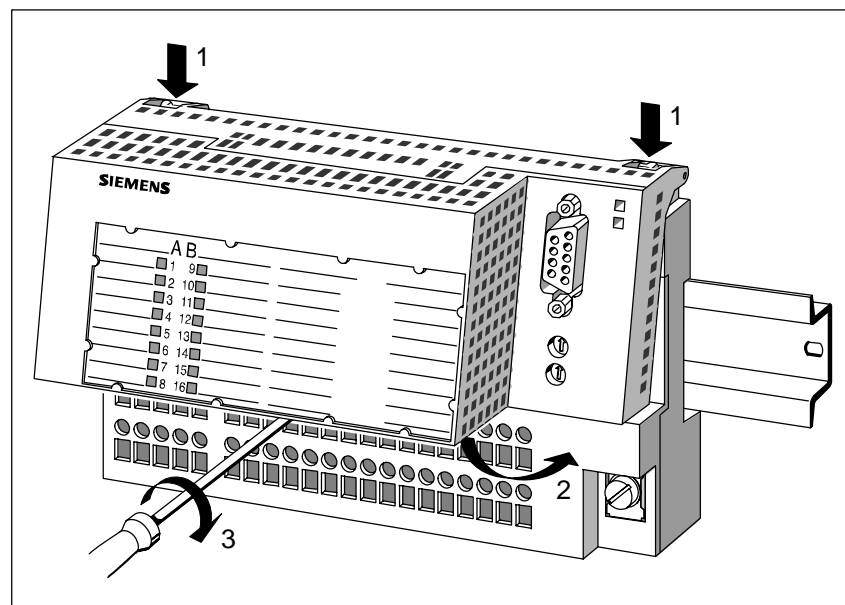

Figure 2-3 Installing the Electronics Block

Disassembling the Electronics Block

To disassemble the electronics block, proceed in the reverse order.

1. Turn off the power supply.
2. Remove the bus connector.
3. Loosen the fixing screw.
4. Tilt the electronics block forwards.

2.3 Setting the ET 200L PROFIBUS Address

Introduction

The PROFIBUS address defines the address of the ET 200L distributed I/O device on the PROFIBUS-DP.

Location of Rotary Switches

The two rotary switches for the PROFIBUS address are located on the electronics block beneath the bus connector.

Tip: You must set the PROFIBUS address before clipping on the bus connector. When clipped on, the bus connector conceals the two rotary switches.

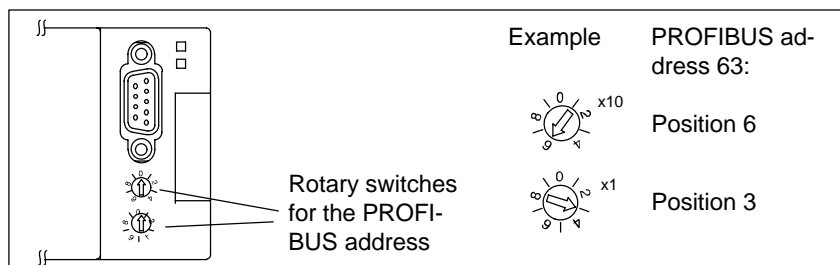

Modifying the PROFIBUS Address

You modify the PROFIBUS address at the two rotary switches by using a small screwdriver. PROFIBUS addresses 1 to 99 are authorized for the ET 200L distributed I/O device.

PROFIBUS address 0, which is set when the ET 200 distributed I/O system leaves the works, is reserved for a PU or PC. Any change made to the PROFIBUS address takes effect when the supply voltage is turned on.

3

Wiring

Introduction

The ET 200L distributed I/O device has been designed for simple wiring. To this end, the label of the ET 200L distributed I/O device has been made self-explanatory.

In this chapter, you will find additional information on wiring the ET 200L distributed I/O device.

Procedure

The wiring of the ET 200L distributed I/O device involves several steps. We suggest you adhere to the following sequence:

	Procedure	Section
Important information on wiring	1. General rules and regulations	3.1
	2. Configuring the electrical installation	3.2
	3. Wiring rules	3.3
Wiring the ET 200L	1. Wire the ET 200L TB 16L/TB 32L terminal block	3.4

Contents of the Chapter

Section	Topic	Page
3.1	General Rules and Regulations	3-2
3.2	Configuring the Electrical Installation	3-4
3.3	Wiring Rules	3-8
3.4	Wiring the ET 200L TB 16L/TB 32L Terminal Block	3-10

3.1 General Rules and Regulations

Introduction

As a component part of a plant or system, the ET 200L distributed I/O device necessitates observance of special rules and regulations, depending on where it is to be used.

This section provides an overview of the most important rules which you have to observe for integrating the ET 200L distributed I/O device in a plant or system.

Specific Application

Observe the safety and accident prevention regulations – for example, the machine protection guidelines – for specific applications.

EMERGENCY STOP Devices

EMERGENCY STOP devices conforming with IEC 204 (corresponds to DIN VDE 113) must remain effective in all the operating modes of the plant or system.

Plant Start-up After Certain Events

The following table shows the points you have to take into account upon start-up of a plant following certain events.

If ...	Then ...
Start-up follows a voltage drop or failure Start-up of the ET 200L follows an interruption of bus communications	No hazardous operating states may occur. Force an EMERGENCY STOP, if necessary.
Start-up follows unlocking of the EMERGENCY STOP device ET 200L start-up occurs without the DP master addressing the ET 200L	There must not be an uncontrolled or undefined start-up.

Supply Voltage

The following table shows you the items you have to take into account in respect of the supply voltage.

With ...	It Is Essential That ...
A permanently installed plant or system not having an all-pole supply isolating switch	A supply isolating switch or a fuse be present in the building installation
Load current power supplies, power supply modules	The set rated voltage range corresponds to the local supply voltage
All circuits of the ET 200L distributed I/O device	The fluctuation or deviation of the supply voltage from the rated value be within the permitted tolerance (refer to Section 6.6)

24 VDC Supply

The following table shows the points that you have to take into account in respect of the 24 VDC supply.

With ...	Pay Attention to...	
Buildings	Outdoor lightning protection	Take lightning protection precautions – for example, lightning conductors
24 VDC supply lines, signal lines	Indoor lightning protection	
24 VDC supply	Safe (electrical) isolation of extra-low voltage	

Protection Against External Electrical Phenomena

The following table shows you the items you have to take into account in respect of protection against electrical phenomena or faults.

With ...	Pay Attention to:
Any plant or system in which the ET 200L is installed	Is the plant or system connected to a protective conductor for diverting electromagnetic interference?
Connecting leads, signal and bus lines	Are the wiring arrangement and installation correct?
Signal and bus lines	Any break of a line or conductor must not result in undefined states of the plant or system.

3.2 Configuring the Electrical Installation

Introduction

In this section, you will find information on the overall installation of an ET 200L distributed I/O device on a grounded supply (TN-S system). The specific topics discussed are:

- Circuit-breaking devices, short-circuit and overload protection in accordance with DIN VDE 0100 and DIN VDE 0113
- Load current power supplies and load circuits.

Definition: Grounded Supply

With grounded supplies, the neutral conductor of the system is grounded. A mere ground fault between a live conductor and ground or a grounded section of the plant causes the protective devices to trip.

Components and Protective Measures

Different components and protective measures are specified for erecting a complete plant. The types of component and the degree to which the protective measures are binding depend on the DIN VDE regulation that applies to the installation of your plant. The following table refers to Figure 3-1.

Table 3-1 DIN VDE Regulations for Installation of a Controller

Compare ...	Ref. to Fig. 3-1	DIN VDE 0100	DIN VDE 0113
Circuit-breaking device for PLC, sensors and signal control elements	①	... Part 460: Main switch	... Part 1: Disconnecter
Short-circuit and overload-protection: Grouped for sensors and signal control elements	②	... Part 725: Single-pole protection of circuits	... Part 1: <ul style="list-style-type: none"> • With grounded secondary circuit: single-pole protection • In all other cases: all-pole protection
Load current power supply for AC load circuits with more than five electromagnetic apparatus	③	Galvanic isolation by means of a transformer is recommended	Galvanic isolation by means of a transformer is essential

Note

The ET 200L cannot be operated with an ungrounded supply.

Characteristics of Load Current Power Supplies

The load current power supply feeds input and output circuits (load circuits) as well as sensors and actuators. The following table lists the characteristics of load current power supplies that are required in specific applications.

Characteristic of Load Current Power Supply	Required for ...	Remarks
Safe (electrical) isolation	Modules that have to be supplied with voltages ≤ 60 VDC or ≤ 25 VAC	Power supply PS 307 and Siemens Series 6EP1 load current power supplies have this characteristic
	24 VDC load circuits	
Output voltage tolerances: 20.4 V to 28.8 V	24 VDC load circuits	If the output tolerances are exceeded, we recommend that you install a back-up capacitor. Rating: 200 μ F per 1 A load current (with full-wave rectification).

Rule: Ground Load Circuits

Load circuits should be grounded.

Fault-free operating reliability is ensured by the common reference potential (ground). Install a detachable connection to the protective conductor on the external power supply (terminal L or M) or on the isolation transformer (Figure 3-1, [4]). This measure makes it simpler for you to locate ground faults in the power distribution system.

EMC

You will find notes on EMC-compatible installation and wiring in the manual for the DP master you are using or for the host system.

Take into account the following notes on EMC-compatible installation of the ET 200L distributed I/O device:

- We recommend that you place the cable shield of the PROFIBUS-DP on both sides of a shield bus.
- The chassis ground and the ground terminal are interconnected in the ET 200L distributed I/O device. Connect the ground terminal of the ET 200L distributed I/O device using a copper cable of at least 2.5 mm² to the central grounding point in the installation cabinet.

ET 200L in Overall Installation

Figure 3-1 shows the location of the ET 200L in the overall system (load current voltage supply and grounding philosophy) for supply from a TN-S system.

Remark: The arrangement of the power supply connections shown in the figure does not correspond to the actual arrangement but was chosen for the sake of clarity.

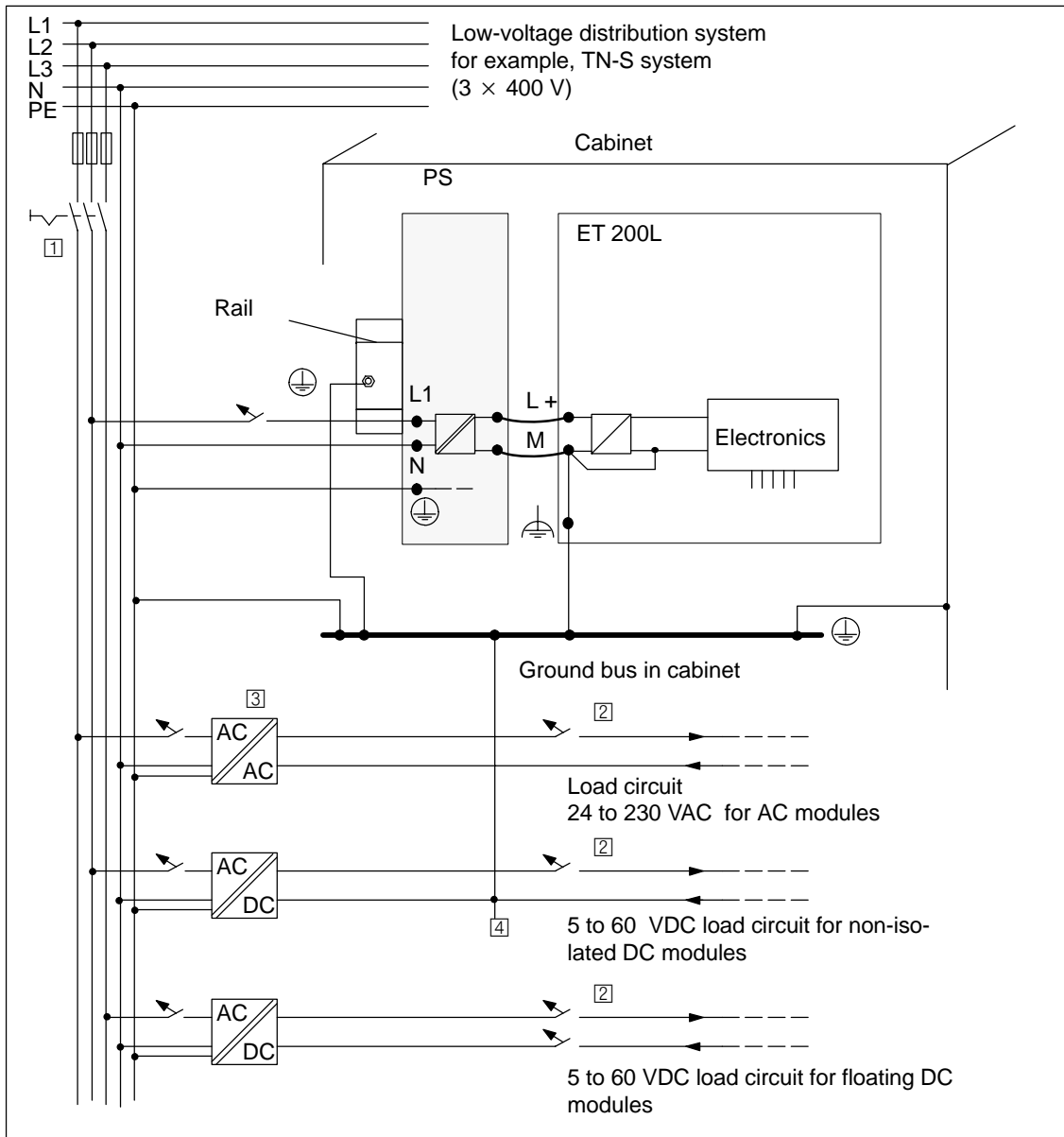

Figure 3-1 Operating the ET 200L from a Grounded Supply

Protected by circuit breaker

In the case of new variants of the following components, the load voltage terminals 1L+, 2L+, and 3L+ used for the sensor power supply of the inputs can be protected using a circuit breaker with a maximum of 6 A (B or C characteristic).

Kapitel	Komponente	MLFB neue Variante	MLFB alte Variante
8.1	ET 200L with 16 DI	6ES7131-1BH01-0XB0	6ES7131-1BH00-0XB0
8.3	ET 200L with 32 DI	6ES7131-1BL01-0XB0	6ES7131-1BL00-0XB0
8.5	ET 200L with 16 DI/DO in each case	6ES7133-1BL01-0XB0	6ES7133-1BL00-0XB0

**Warning**

In the old variants of the above components, the sensor power supply may only be loaded with 5 A per input byte. The load voltage terminals 1L+, 2L+, and 3L+ should be protected accordingly.

3.3 Wiring Rules

Rules for Wiring The table below shows you what you must observe when wiring the terminal block and the supplementary terminal.

Table 3-2 Pinout of the PROFIBUS-DP Terminal Connection

Rules for ...	Terminal block	
	Spring Terminal	Screw-Type Terminal
Suitable cable cross-sections:		
Solid cables	0.14 to 1.5 mm ² (for PI connection: 2.5 mm ²)	
Flexible cables		
• Without wire end ferrule	0.14 to 1.5 mm ² (for PI connection: 2.5 mm ²)	
• With wire end ferrule	0.14 to 1.5 mm ²	
Number of cables per connection	1 or combination of 2 cables to a total of 1.5 mm ² in one wire end ferrule	
Max. diameter of cable insulation	Ø 3.1 mm Ø 3.8 mm for 2.5 mm ²	
Insulation stripping length of the cables		
• Without insulation collars	7 to 11 mm	
• With insulation collars	7 to 11 mm	
Wire end ferrule in accordance with DIN 46228		
• Without insulation collars	Shape A; up to 12 mm long	Shape A; up to 12 mm long
• With insulation collars		
– 0.25 to 1.0 mm ²	Shape E; up to 12 mm long	Shape E; up to 12 mm long*
– 1.5 mm ²	Shape E; 12 mm long	Shape E; 12 mm long*
Blade width of the screwdriver	3.5 mm (cylindrical design)	
Tightening torque for connecting cables (not applicable to spring terminals)	–	0.4 to 0.7 Nm
Ground connection	up to 6 mm ² in cable lug for M4 screw	

* Without insulation collars

Terminal Block with Screw-Type Terminal

To wire the terminal block (screw-type terminal), proceed as follows:

1. Strip the insulation of the wires down to 11 mm.
2. Connect the conductors. Begin on the left under the terminal block.
3. Screw the ends of the cables onto the terminal block with a tightening torque of 0.5 Nm. Tighten the screws on the unwired terminals as well.

Terminal Block with Spring Terminal

To wire the terminal block (spring terminal), proceed as follows:

1. Strip the insulation of the wires down to 11 mm.

Remember to:

- Insert the screwdriver in the lower opening.
- Insert the cable in the upper opening until the stop.

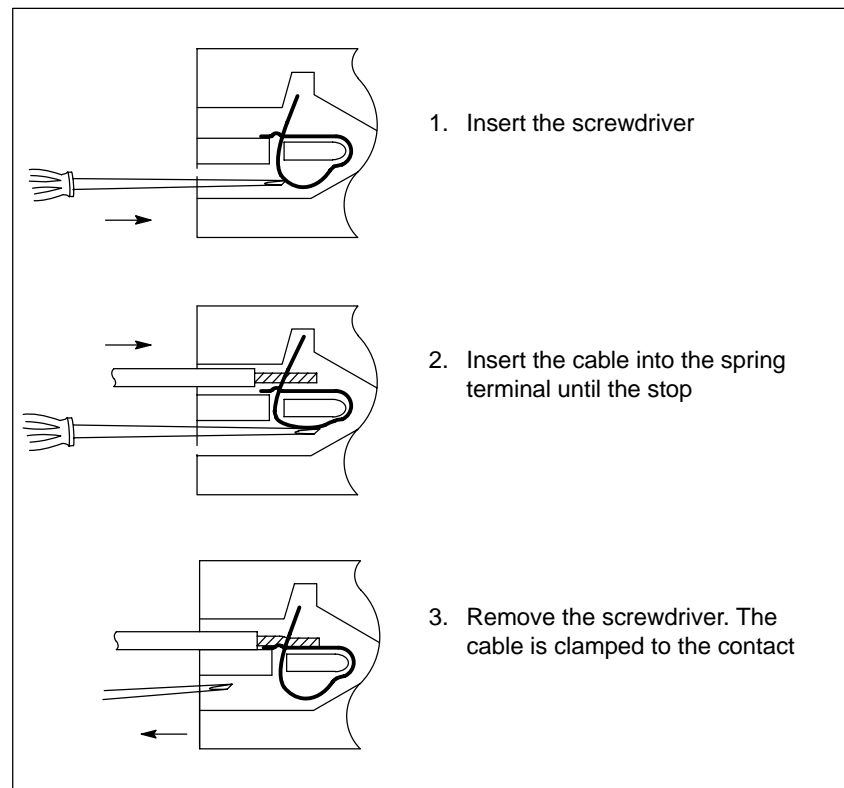

Figure 3-2 How the Spring Terminal Works

4. Release the spring terminal of the first connection using a screwdriver (0.5 x 3.5 mm DIN 5264). Begin at the bottom left of the terminal block.
5. Push the first wire into the released spring terminal and withdraw the screwdriver.
6. Repeat steps 1 to 3 for all other wires.



Warning

There is a risk of injury and damage to property.

Connecting different phases of a three-phase system to a terminal block can cause injury and damage to property.

Connect only one phase to each terminal block.

3.4 Wiring the ET 200L TB 16L/TB 32L Terminal Block

Introduction

When wiring the ET 200L distributed I/O device, we distinguish between the terminal block with its supplementary terminal and the electronics block.

- The terminal block and, if required, the supplementary terminal carry the wiring.
- The electronics block incorporates the PROFIBUS-DP connection.

Wiring the Terminal Block

All terminal connections on the terminal block and supplementary terminals are located on the front and are clearly marked and readily visible from the front. Assignment of terminal connections to input/output channels is simple to perform, without danger of confusion.

Connect the terminal block and the supplementary terminal in accordance with the configuration. Figure 3-3 shows the terminal connections for terminal block TB 16L. Its pinout is described in Chapter 7.

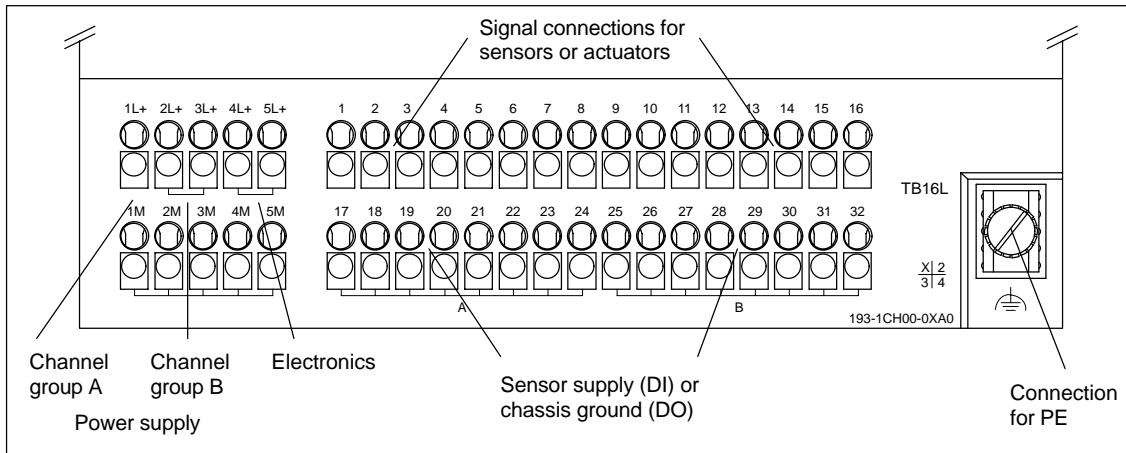

Figure 3-3 Terminal Connections on Terminal Block TB 16L

Connecting the Voltage Supply

There are three different ways to connect the voltage supply to the terminal block.

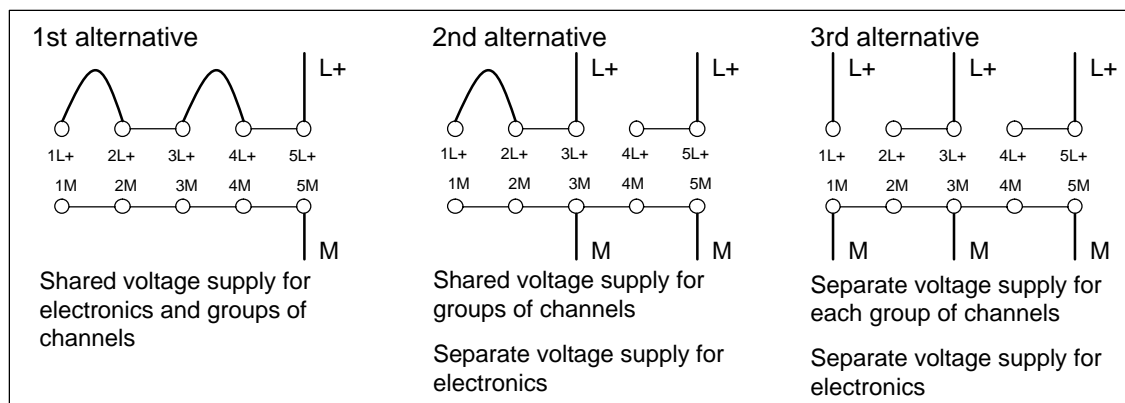

Figure 3-4 Alternative Ways of Connecting the Voltage Supply

Block Diagram

The block diagrams relating to the ET 200L distributed I/O device will be found in Chapter 7.

Label

A labeling strip is located on the front of the electronics block for noting the assignment of inputs and outputs.

Terminal Connection Model

A terminal connection model showing the terminal connection assignment and electrical connections is located beneath the labeling strip on the electronics block (refer to Chapter 8).

Clipping on the Bus Connector

Clip the bus connector on the electronics block.

1. Clip the bus connector on the PROFIBUS-DP terminal connection after setting the PROFIBUS address of the ET 200L distributed I/O device (refer to Section 2.3).
2. Tighten the fastening screws of the bus connector.

PROFIBUS-DP Terminal Connection

The table below describes the pinout of the 9-pin PROFIBUS-DP terminal connection.

Table 3-3 Pinout of the PROFIBUS-DP Terminal Connection

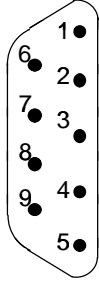
View	Pin No.	Signal Name	Description
	1	–	–
	2	–	–
	3	RxD/TxD-P	Data line B
	4	RTS	Request To Send
	5	M5V2 ¹	Data reference potential (from station)
	6	P5V2 ¹	Supply Plus (from station)
	7	–	–
	8	RxD/TxD-N	Data line A
	9	–	–

¹ For connecting an ET 200 handheld or an optical-fiber module

Commissioning

4

Contents of the Chapter

Section	Topic	Page
4.1	Configuration Software	4-1
4.2	Commissioning the ET 200L	4-2

4.1 Configuration Software

ET 200L

You configure the ET 200L distributed I/O device and SC using the following configuration software.

- COM ET 200 Windows as of Version 1.0
- COM PROFIBUS as of Version 3.0
- STEP 7 as of Version 2.1

You will find the name of the type file for the various electronics blocks and the contents of the device master file described in Appendix B.

4.2 Commissioning the ET 200L

Commissioning the ET 200L

Commission the ET 200L distributed I/O device as follows:

Step	Activity	Explanation
1	Install and wire up the ET 200L.	You will find detailed instructions on installing and wiring in Chapters 2 and 3.
2	Set the PROFIBUS address of the ET 200L.	The two rotary switches used to set the PROFIBUS address are concealed by the bus connector (refer to Section 2.3).
3	Clip the bus connector on the electronics block.	
4	Turn on the power supply for the ET 200L. Result: The ET 200L starts up automatically.	—

Note

Full operational safety of the electronics blocks is not ensured until you have applied the labeling strips to the front of the electronics blocks (electrostatic discharge at the front of the module, LED coverage).

Start-up

The ET 200L distributed I/O device starts up automatically when the power supply is turned on. A separate switch is not available.

During start-up, both LEDs (ON and BF =**B**us **F**ault) are on.

The ET 200L distributed I/O device ...

- Sets the outputs to "0".
- Applies the PROFIBUS address from the two rotary switches.
- Receives the configuration data from the DP master and evaluates the details contained in the configuration data. If the configuration agrees with the installation, the ET 200L distributed I/O device initiates data exchange, and the BF LED goes off.

Data Exchange

After start-up, data exchange is initiated between the DP master and the ET 200L distributed I/O device.

The data exchange is displayed by the ET 200L distributed I/O device as follows:

- The green operating LED (ON) is on.
- The bus fault LED (BF) is off.
- The inputs and outputs are enabled.
- Conductive inputs and outputs are indicated on the status LEDs by the corresponding LED flashing.

5

Diagnostics

Introduction

The ET 200L distributed I/O device was designed to make working with and commissioning it as simple as possible. If a failure nevertheless occurs, you can find out what it is by means of LEDs and slave diagnostics.

Contents of the Chapter

Section	Topic	Page
5.1	Diagnostics Using the LEDs	5-2
5.2	Slave Diagnostics	5-3

5.1 Diagnostics Using the LEDs

Introduction The ET 200L distributed I/O device features the following diagnostic options:

- LEDs
- Slave diagnostics (refer to Section 5.2)

Status Display Each input and output of the ET 200L distributed I/O device has a status display. The status display LED lights up when the input or output is active.

ET 200L LED Display The ET 200L distributed I/O device has two LEDs for displaying statuses.

Table 5-1 Diagnostics Using the LED Display

BF LED (Bus Fault)	ON LED	Meaning	Error Handling
Off	Off	<ul style="list-style-type: none"> • No voltage is being applied to the ET 200L. • An ET 200L hardware fault has occurred. 	<ul style="list-style-type: none"> • Check the power supply. Switch on the on-off switch for 24 VDC on the power supply module. • Check whether the electronics block is properly secured on the terminal block.
On	On	<ul style="list-style-type: none"> • ET 200L is in the process of startin up. • A modified PROFIBUS address is only effective following POWER-OFF/POWER-ON. 	–
		<ul style="list-style-type: none"> • The connection to the DP master has failed. • ET 200L has still not received any configuration data. 	<ul style="list-style-type: none"> • Check the PROFIBUS connection. • Check the DP master. • Check the configuration in the DP master (station type, input/output, PROFIBUS address). • Check which PROFIBUS address has been set.
Off	On	Data exchange	–

5.2 Slave Diagnostics

In Section 5.2

You will find the following topics in this section:

Section	Topic	Page
5.2.1	Structure of the Slave Diagnosis	5-4
5.2.2	Structure of Station Statuses 1 to 3, Master Station Number and Manufacturer Identification	5-5

Definition

Diagnostics is the detection and localization of errors. The diagnostics structure is laid down in *IEC 61784-1:2002 Ed1 CP 3/1*. ET 200L diagnostics complies with this standard. Slave diagnostics is explained in the section that follows for the ET 200L.

5.2.1 Structure of the Slave Diagnosis

Introduction

The diagnostics of the ET 200L distributed I/O device comply with IEC 61784-1:2002 Ed1 CP 3/1. The slave diagnosis is explained below.

Structure of the Slave Diagnosis

The slave diagnosis comprises 6 bytes for the ET 200L:

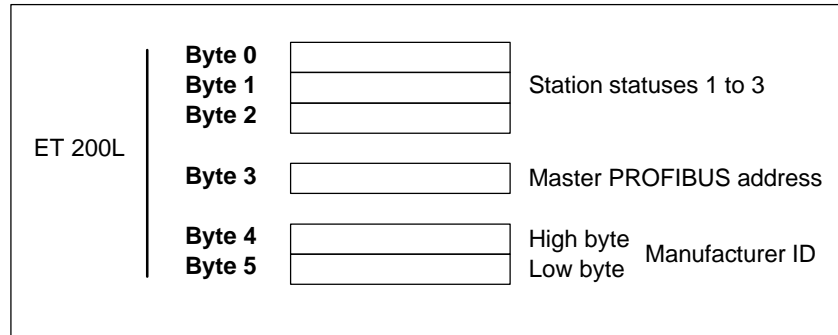

Figure 5-1 Structure of the Slave Diagnosis

Requesting a Slave Diagnosis

You can request a slave diagnosis with the following function blocks:

Table 5-2 Function Blocks for Slave Diagnosis

PLC Family	Number	Name
SIMATIC S5 with IM 308-C	FB 192 192	FB IM308C
SIMATIC S7/M7	SFC 13 13	SFC "DPNRM_DG"
S5-95U with DP master interface	FB 230 230	FB S_DIAG
SIMATIC S5 with CP 5431 DP/FMS	Communication function blocks (see standard FBs) SEND and RECEIVE with job number 209	

5.2.2 Structure of Station Statuses 1 to 3, Master Station Number and Manufacturer Identification

Definition of Station Status Station statuses 1 to 3 provide an overview of the status of a DP slave (refer to Figure 5-1, bytes 0 to 2).

Structure of Station Status 1 Station status 1 provides information about the DP slave and is structured as follows:

Table 5-3 Structure of Station Status 1 (Byte 0)

Bit	Meaning	Action
0	1: The DP slave cannot be addressed by the DP master.	<ul style="list-style-type: none"> • Correct PROFIBUS address set on ET 200L? • Bus connector connected? • Voltage at DP slave? • RS 485 repeater set correctly? • Supply voltage ON/ OFF performed on ET 200L?
1	1: The DP slave is not yet ready to exchange data.	<ul style="list-style-type: none"> • Wait, because the ET 200L is just being powered up.
2	1: The configuration data sent by the DP master to the DP slave do not agree with the installation of the DP slave.	<ul style="list-style-type: none"> • Correct station type or correct installation of the ET 200L entered in the system configuration software?
3	1: An external diagnosis exists.	<ul style="list-style-type: none"> • Check the contents of the external diagnosis.
4	1: The requested function is not supported by the DP slave.	<ul style="list-style-type: none"> • Check the configuration.
5	1: The DP master cannot interpret the reply from the DP slave.	<ul style="list-style-type: none"> • Check the bus installation.
6	1: The DP slave type does not agree with the software configuration.	<ul style="list-style-type: none"> • Correct station type entered in the system configuration software?
7	1: Parameters have been assigned to the DP slave by a different DP master from that which currently has access to the DP slave.	<ul style="list-style-type: none"> • The bit is always 1 if you are in the process of accessing, for example, the ET 200L with the PU or another DP master. The PROFIBUS address of the parameterization master is located in the "master PROFIBUS address" diagnostic byte.

Structure of Station Status 2

Station status 2 provides additional information about the DP slave and is structured as follows:

Table 5-4 Structure of Station Status 2 (Byte 1)

Bit	Meaning
0	1: Parameters have to be assigned again to the DP slave.
1	1: A diagnostic message has been issued. The DP slave cannot resume operation until the fault has been corrected (static diagnostic message).
2	1: The bit is always set to "1" if the DP slave having this PROFIBUS address is present.
3	1: Response monitoring has been enabled for this DP slave.
4	1: The DP slave has received the "FREEZE" control command ¹ .
5	1: The DP slave has received the "SYNC" control command ¹ .
6	1: The bit is always set to "0".
7	1: The DP slave is disabled – that is, it has been removed from the processing in progress.

¹ The bit is updated only if another diagnostic message changes too.

Structure of Station Status 3

Station status 3 is reserved and is not relevant in as far as the diagnostics of the ET 200L distributed I/O device are concerned.

Definition of the Master PROFIBUS Address

The Master PROFIBUS Address diagnostic byte stores the PROFIBUS address of the DP master which has assigned parameters to the DP slave (refer to Figure 5-1, byte 3).

Structure of the Master PROFIBUS Address

The master PROFIBUS address comprises one byte with the PROFIBUS address of the DP master that assigned parameters to the DP slave and has read and write access to the DP slave.

Definition of the Manufacturer ID

A code is stored in the manufacturer identification that describes the type of the DP slave (refer to Figure 5-1, bytes 4 and 5).

Structure of the Manufacturer ID

The manufacturer identification of the DP slave comprises two bytes. You will find the manufacturer identifications of the different electronics blocks in Appendix, Table B-4.

6

General Technical Data

What Is General Technical Data?

The general technical data consists of the standards and test values with which the ET 200L conforms and which it fulfills, and the test criteria by which the ET 200L distributed I/O device was tested.

Contents of the Chapter

Section	Topic	Page
6.1	Standards and Certification	6-2
6.2	Electromagnetic Compatibility	6-4
6.3	Shipping and Storage Conditions	6-6
6.4	Mechanical and Climatic Environmental Conditions	6-7
6.5	Details of Insulation Testing, Safety Class, and Degree of Protection	6-8
6.6	Rated Voltage of the ET 200L Distributed I/O Device	6-9

6.1 Standards and Certification

Introduction This chapter contains information the following for the modules and components of the ET 200L:

- The most important standards complied with by the ET 200L
- The certification of the ET 200L

IEC 1131 The ET 200L distributed I/O device meet the requirements and criteria of IEC 1131, Part 2.

PROFIBUS DP The ET 200L distributed I/O device meet the requirements and criteria of *IEC 61784-1:2002 Ed1 CP 3/1*.

CE Marking Our products fulfill the requirements and safety objectives of the following EC Directives and comply with the harmonized European standards (EN) published for stored-program controllers in the official journals of the European Communities:



- 89/336/EEC Electromagnetic Compatibility Directive
- 73/23/EEC Low Voltage Directive (for electrical equipment)

The EC Declarations of Conformity are available to the relevant authorities at the following address:

Siemens Aktiengesellschaft
Bereich Automatisierungstechnik
A&D AS E 14
Postfach 1963
D-92209 Amberg

PNO The ET 200L has the following PNO certificates:

Product Name	Order Number	Release	PNO Certificate
ET 200L 16 DI DC 24 V	6ES7 131-1BH01-0XB0	1	Z00179
ET 200L 32 DI DC 24 V	6ES7 131-1BL01-0XB0	1	Z00180
ET 200L 16 DO DC 24 V/0.5 A	6ES7 132-1BH00-0XB0	1	Z00181
ET 200L 32 DO DC 24 V/0.5 A	6ES7 132-1BL00-0XB0	1	Z00182
ET 200L 16 DI/16 DO DC 24 V/0.5 A	6ES7 133-1BL01-0XB0	1	Z00183

UL Recognition UL Recognition Mark
Underwriters Laboratories (UL) to
Standard UL 508, File No. 116536

CSA Certification CSA Certification Mark
Canadian Standard Association (CSA) to
Standard C22.2 No. 142, File No. LR 48323

FM Approval Factory Mutual Approval Standard Class Number 3611, Class I, Division 2,
Group A, B, C, D.



Warning

There is a risk of injury and damage to property.

In potentially explosive atmospheres, there is a risk of injury to people and damage to property if you disconnect connectors when a ET 200 is in operation.

Always de-energize the ET 200 in potentially explosive atmospheres before disconnecting any connectors.

6.2 Electromagnetic Compatibility

Definition

Electromagnetic compatibility is the ability of an electric device to function satisfactorily in its electromagnetic environment without interfering with this environment.

The ET 200L distributed I/O device also meets the requirements, among others, of the EMC act of the European inner market. A requirement for this is that the ET 200L distributed I/O device meets the specifications and directives concerning electrical installation.

Pulse-Shaped Interference

The following table shows the electromagnetic compatibility of the ET 200L distributed I/O device with regard to pulse-shaped interference.

Pulse-Shaped Interference	Tested with	Corresponds to Severity
Electrostatic discharge to IEC 801-2 (DIN VDE 0843, Part 2)	8 kV 4 kV	3 (air discharge) 2 (contact discharge)
Burst impulses in accordance with IEC 801-4 (DIN VDE 0843, Part 4)	2 kV (supply line) 2 kV (signal line)	3
Surge in accordance with IEC 801-5 (DIN VDE 0839, Part 10) Only with lightning protection elements (refer to DP master manual).		
<ul style="list-style-type: none"> • Asymmetrical connection • Symmetrical connection 	2 kV (supply line) 2 kV (signal line/data line) 1 kV (supply line) 1 kV (signal line/data line)	3

Sine-Shaped Interference

The following table shows the electromagnetic compatibility of the ET 200L distributed I/O device with regard to sine-shaped interference.

HF Radiation to ENV 50140 (Corresponds to IEC 801-3) Electromagnetic RF Field		RF Coupling to ENV 50141 (Corresponds to IEC 801-6)
Amplitude-Modulated	Pulse-Modulated	
80 to 1000 MHz	900 MHz ± 5 MHz	0.15 to 80 MHz
10 V/m		10 V _{rms} unmodulated
80 % AM (1 kHz)	50 % ED	80 % AM (1 kHz)
	200 Hz repetition frequency	150 Ω source impedance

Emission of Radio Interference

Emitted interference of electromagnetic fields in accordance with EN 55011: Limit Value Class A, Group 1 (measured at a distance of 30 m).

Frequency	Emitted Interference
From 20 to 230 MHz	< 30 dB (μV/m)Q
From 230 to 1000 MHz	< 37 dB (μV/m)Q

6.3 Shipping and Storage Conditions

Conditions

The ET 200L distributed I/O device surpasses the requirements of IEC 1131, Part 2, with regard to shipping and storage conditions. The following details apply to modules that are shipped and stored in their original packaging.

Type of Condition	Admissible Range
Free fall	\leq 1m
Temperature	From - 40 °C to + 70 °C
Temperature variation	20 K/h
Air pressure	From 1080 to 660 hPa (corresponds to a height of -1000 to 3500 m)
Relative humidity	From 5 to 95 %, without condensation

6.4 Mechanical and Climatic Environmental Conditions

Climatic Environmental Conditions

The following climatic environmental conditions apply:

Environmental Conditions	Operating Ranges	Remarks
Temperature	From 0 to 60 °C From 0 to 40 °C	Horizontal wall mounting All other installation positions
Temperature variation	10 K/h	
Relative humidity	From 15 to 95 %	Without condensation, corresponds to relative humidity (RH) stress rate 2 to IEC 1131-2
Air pressure	From 1080 to 795 hPa	Corresponds to a height of -1000 to 2000 m
Contaminant concentration	SO ₂ : < 0.5 ppm; rel. humidity < 60 %, no moisture condensation H ₂ S: < 0.1 ppm; rel. humidity < 60 %, no moisture condensation	Test: 10 ppm; 4 days 1 ppm; 4 days

Mechanical Environmental Conditions

The mechanical environmental conditions are shown in the following table in the form of sinusoidal oscillations.

Frequency Range	Permanent	Occasional
$10 \leq f \leq 58$ Hz	0.0375 mm amplitude	0.075 mm amplitude
$58 \leq f \leq 150$ Hz	0.5 g constant acceleration	1 g constant acceleration

Testing Mechanical Environmental Conditions

The following table provides information on the type and extent of tests of mechanical environmental conditions.

Test for ...	Test Standard	Remarks
Oscillations	Oscillation test to IEC 68, Part 2-6 (sine)	Oscillation type: frequency sweeps with a rate of change of 1 octave per minute. $10 \text{ Hz} \leq f \leq 58 \text{ Hz}$, const. amplitude 0.075 mm. $58 \text{ Hz} \leq f \leq 150 \text{ Hz}$, const. acceleration 1 g. Oscillation time: 10 frequency sweeps per axis in all of the three perpendicular axes.
Shock	Shock test to IEC 68, Part 2-27	Type of shock: half sine Force of shock: 15 g peak value, 11 ms duration Direction of shock: 3 shocks per +/- direction in all of the three perpendicular axes.

6.5 Details of Insulation Testing, Safety Class, and Degree of Protection

Test Voltage Insulation strength is demonstrated in the routine test with the following test voltage in accordance with IEC 1131, Part 2:

Circuits with a Rated Voltage U_e to Other Circuits or to Ground	Test Voltage
$0 \text{ V} < U_e \leq 50 \text{ V}$	500 VDC

Safety Class Safety class II in accordance with IEC 536 (VDE 0106, Part 1) – that is, connection to a protective conductor is not necessary.

Protection Against Foreign Matter and Water IP 20 degree of protection in accordance with IEC 529 – that is, protection against contact with standard test fingers.
Furthermore, it is protected against foreign matter having a diameter greater than 12.5 mm.
No special protection against water.

6.6 Rated Voltage of the ET 200L Distributed I/O Device

Rated Voltage for Operation

The ET 200L distributed I/O device operates with the rated voltage and corresponding tolerances shown in the following table.

Table 6-1 Rated Voltage of the ET 200L Distributed I/O Device

Rated Voltage	Tolerance Range
24 VDC	20.4 to 28.8 VDC

Bridging Voltage Drops

The ET 200L distributed I/O device bridges voltage drops of the power supply of up to 20 ms long (does not apply to SC electronic modules).

Terminal Blocks and Supplementary Terminals – Technical Data

7

Introduction

The product spectrum of ET 200L includes various terminal blocks to which you can connect different electronics blocks. This chapter contains the technical data for the terminal blocks and their supplementary terminals.

Contents of the Chapter

Section	Subject	Page
7.1	Terminal Block TB 16L – 6ES7193-1CH00-0XA0, 6ES7193-1CH10-0XA0	7-2
7.2	Terminal Block TB 32L – 6ES7193-1CL00-0XA0, 6ES7193-1CL10-0XA0	7-4
7.3	Supplementary Terminals for TB 16L and TB 32L	7-7

7.1 Terminal Block TB 16L – 6ES7193-1CH00-0XA0, 6ES7193-1CH10-0XA0

Order Numbers The TB 16L terminal block is available with two types of connection.

- Connection by means of a screw-type terminal (Order Number 6ES7193-1CH00-0XA0)
- Connection by means of a spring terminal (Order Number 6ES7193-1CH10-0XA0)

Plug-In Electronics Blocks You can connect the following electronics blocks to the TB 16L terminal block:

Chapter	Plug-In Electronics Blocks	Order Number
Chapter 8: ET 200L Electronics Blocks Technical Data	ET 200L 16 DI DC 24 V	6ES7131-1BH01-0XB0
	ET 200L 16 DO DC 24 V/0.5A	6ES7132-1BH00-0XB0

Characteristics The terminal block bears the stationary wiring.

Dimension Drawing In Figure 7-1 you can see the dimension drawing of the TB 16L terminal block with the 16 DI 24 V DC electronics block clipped on.

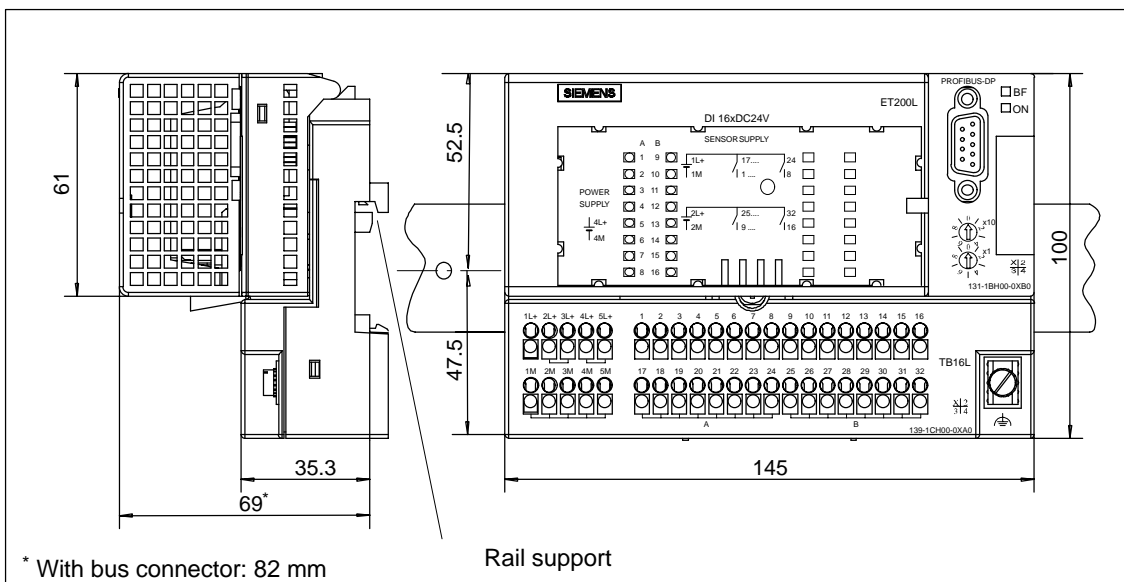

Figure 7-1 The TB 16L Terminal Block with the Electronics Block Clipped On, Dimension Drawing

Pinout

Table 7-1 shows the pinout of the TB 16L terminal block.

Table 7-1 Pinout of the TB 16L Terminal Block

Terminal	Assignment	
	Inputs	Outputs
1 to 8	I0: Signals .0 to .7	Q0: Signals .0 to .7
9 to 16	I1: Signals .0 to .7	Q1: Signals .0 to .7
17 to 24	I0: Sensor supply	Q0: Chassis ground (internally jumpered)
25 to 32	I1: Sensor supply	Q1: Chassis ground (internally jumpered)
1L+	Power supply for channel group A (I0 and Q0)	
2L+	Power supply for channel group B (I1 and Q1) internally jumpered	
3L+		
4L+	Power supply for electronics, internally jumpered	
5L+		
1M	Chassis ground connection for channel group A, channel group B, and electronics (all internally jumpered)	
2M		
3M		
4M		
5M		
⊥	PE	

Technical Data

Dimensions and Weight	
Dimensions W × H × D (mm)	145 × 100 × 40.5
Height with electronics block from top edge rail (with bus terminator 6ES7972-0CA30-0XA0)	82 mm
Weight	230 g
Module-Specific Data	
Number of channels	16

7.2 Terminal Block TB 32L – 6ES7193-1CL00-0XA0, 6ES7193-1CL10-0XA0

- Order Numbers** The TB 32L terminal block is available with two types of connection.
- Connection via screw-type terminal (Order Number 6ES7193-1CL00-0XA0)
 - Connection via spring terminal (Order Number 6ES7193-1CL10-0XA0)

Plug-In Electronics Blocks You can connect the following electronics blocks to the TB 32L terminal block:

Chapter	Plug-In Electronics Blocks	Order Number
Chapter 8:	ET 200L 32 DI DC 24 V	6ES7131-1BL01-0XB0
ET 200L Electronics Blocks	ET 200L 32 DO DC 24 V/0.5 A	6ES7132-1BL00-0XB0
Technical Data	ET 200L 16 DI/16 DO DC 24 V/0.5 A	6ES7133-1BL00-0XB0

Characteristics The terminal block bears the stationary wiring.

Dimension Drawing

In Figure 7-2 you can see the dimension drawing of the TB 32L terminal block with the LSC 32 DI 24 V electronics block clipped on.

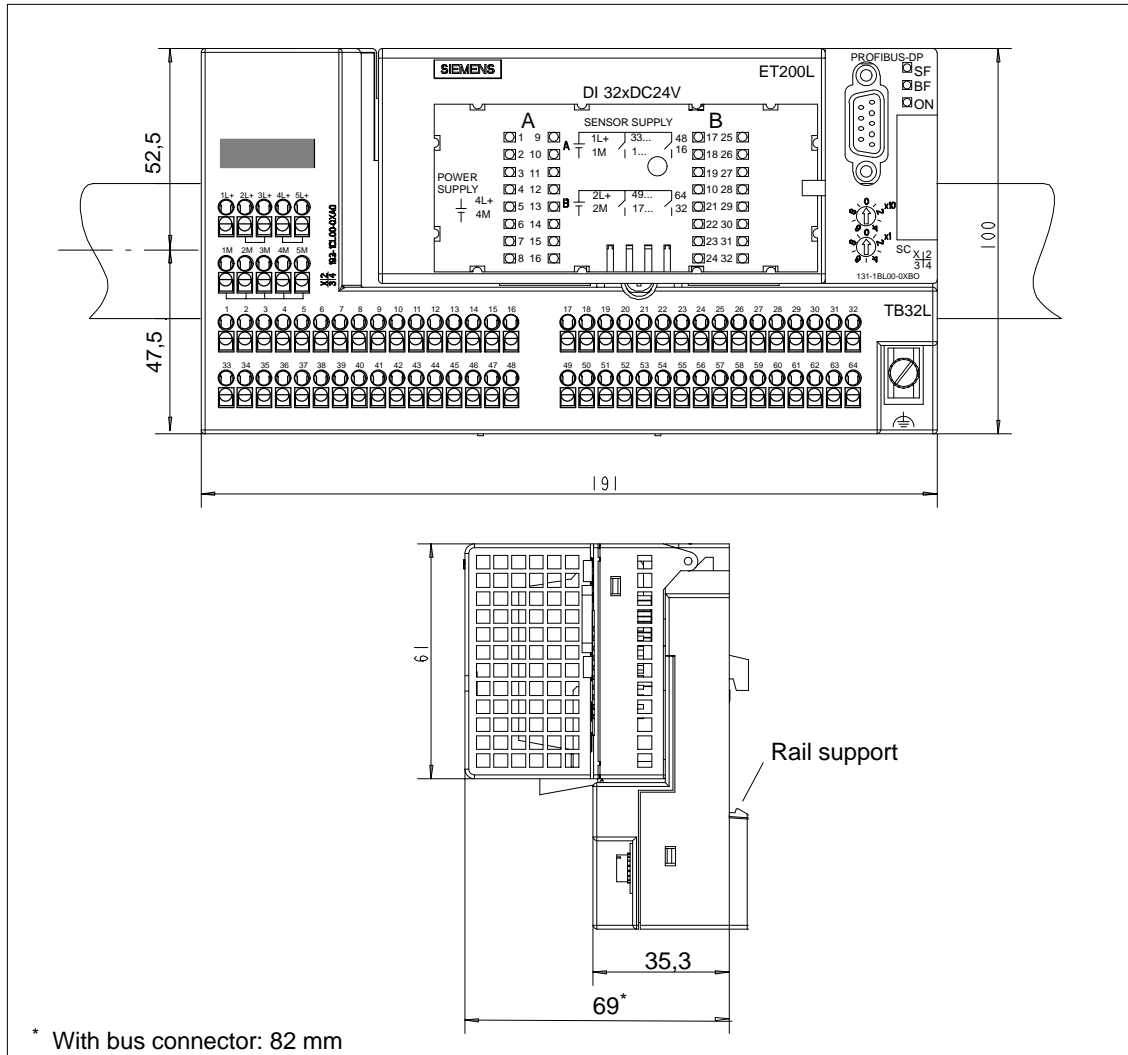

Figure 7-2 The TB 32L Terminal Block with the Electronics Block Clipped On, Dimension Drawing

Pinout

Table 7-2 shows the pinout of the TB 32L terminal block.

Table 7-2 Pinout of the TB 32L Terminal Block

Terminal	Assignment	
	Inputs	Outputs
1 to 8	I0: Signals .0 to .7	Q0: Signals .0 to .7
9 to 16	I1: Signals .0 to .7	Q1: Signals .0 to .7
17 to 24	I2: Signals .0 to .7	Q2: Signals .0 to .7
25 to 32	I3: Signals .0 to .7	Q3: Signals .0 to .7
33 to 40	I0: Sensor supply	Q0: Chassis ground (internally jumpered)
41 to 48	I1: Sensor supply	Q1: Chassis ground (internally jumpered)
49 to 56	I2: Sensor supply	Q2: Chassis ground (internally jumpered)
57 to 64	I3: Sensor supply	Q3: Chassis ground (internally jumpered)
1L+	Power supply for channel group A (I0 and I1 or Q0 and Q1)	
2L+	Power supply for channel group B (I2 and I3 or Q2 and Q3) internally jumpered	
3L+		
4L+	Power supply for electronics, internally jumpered	
5L+		
1M	Chassis ground connection for channel group A, channel group B, and electronics (all internally jumpered)	
2M		
3M		
4M		
5M		
⊥	PE	

Technical Data

Dimensions and Weight	
Dimensions W × H × D (mm)	191 × 100 × 40.5
Height with electronics block from top edge rail (with bus terminator 6ES7972-0CA30-0XA0)	82 mm
Weight	350 g
Module-Specific Data	
Number of channels	32

7.3 Supplementary Terminals for the TB 16L and TB 32L

Definition The supplementary terminals allow you to upgrade the two-wire termination of the ET 200L distributed I/O device to a three- or four-wire termination.

Versions Supplied

Table 7-3 Supplied Versions of the Supplementary Terminals

Channels	Tiers	Fixing	Order Number
16	1	Screw-type terminal	6ES7193-1FH20-0XA0
		Spring terminal	6ES7193-1FH50-0XA0
	2	Screw-type terminal	6ES7193-1FH30-0XA0
		Spring terminal	6ES7193-1FH60-0XA0
32	1	Screw-type terminal	6ES7193-1FL20-0XA0
		Spring terminal	6ES7193-1FL50-0XA0
	2	Screw-type terminal	6ES7193-1FL30-0XA0
		Spring terminal	6ES7193-1FL60-0XA0

Characteristics With the supplementary terminals, every tier is jumpered internally.

Dimension Drawing

Figure 7-3 shows the dimension drawings for the supplementary terminals.

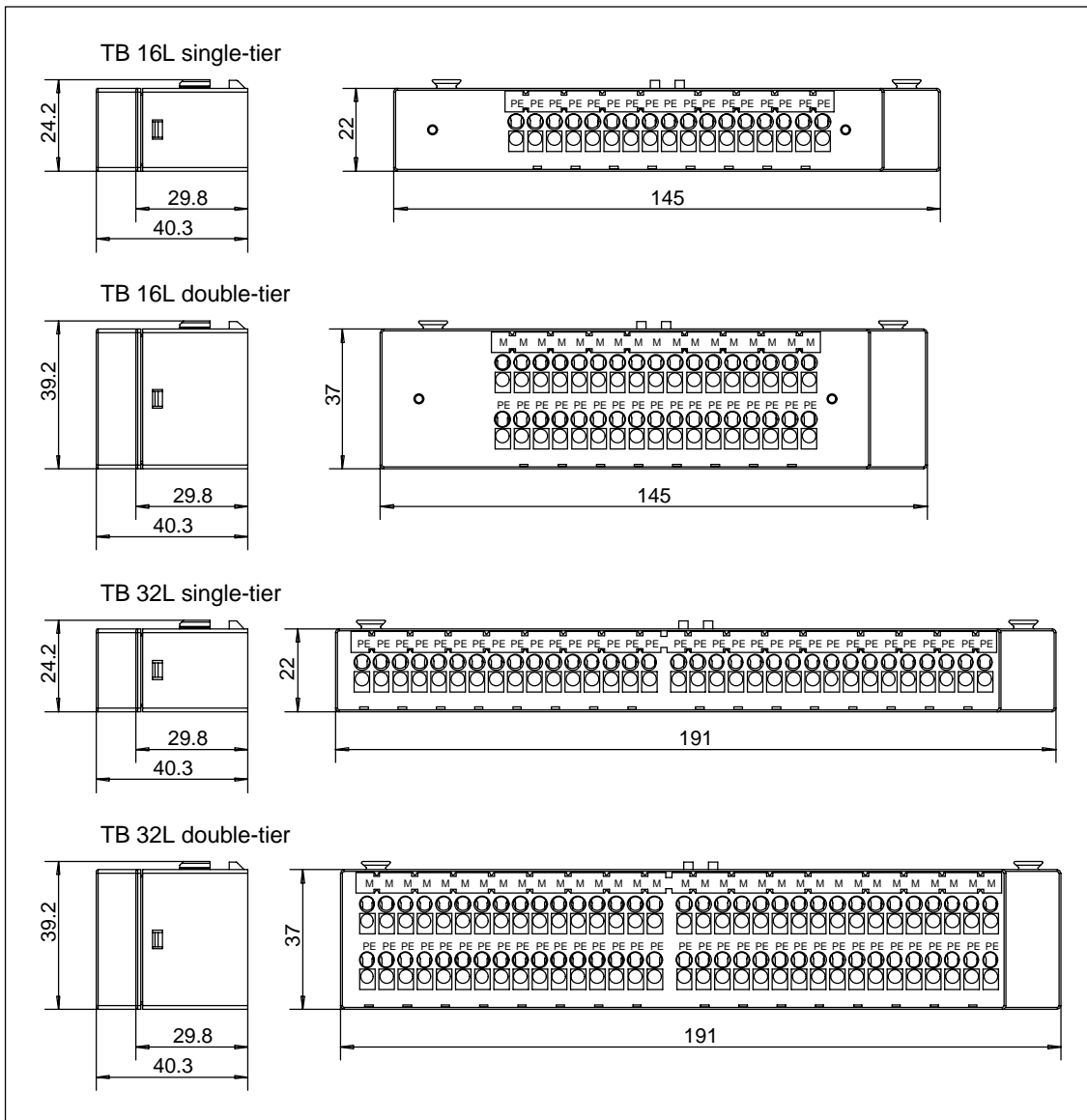

Figure 7-3 TB 16L/TB 32L Supplementary Terminals, Dimension Drawing

ET 200L Electronics Blocks – Technical Data

8

Introduction The components of the ET 200L cannot be upgraded with a Smart Connect. This chapter contains the technical data of the ET 200L electronics blocks.

TB↔EB Assignment The following table contains the assignment of the ET 200L electronic blocks to the terminal blocks.

Table 8-1 Assignment of the ET 200L Electronic Blocks to the Terminal Blocks

Terminal Block	Electronics Block	Order Number
TB 16L – (6ES7193-1CH00-0XA0, 6ES7193-1CH10-0XA0)	ET 200L 16 DI DC 24 V	6ES7131-1BH01-0XB0
	ET 200L 16 DO DC 24 V/0.5A	6ES7132-1BH00-0XB0
TB 32L – (6ES7193-1CL00-0XA0, 6ES7193-1CL10-0XA0)	ET 200L 32 DI DC 24 V	6ES7131-1BL01-0XB0
	ET 200L 32 DO DC 24 V/0.5 A	6ES7132-1BL00-0XB0
	ET 200L 16 DI/16 DO DC 24 V/0.5 A	6ES7133-1BL01-0XB0

Contents of the Chapter

Section	Subject	Page
8.1	Electronics Block L 16 DI DC 24 V – 6ES7131-1BH01-0XB0	8-2
8.2	Electronics Block L 16 DO DC 24 V/0.5 A – 6ES7132-1BH00-0XB0	8-6
8.3	Electronics Block L 32 DI DC 24 V – 6ES7131-1BL00-0XB0	8-9
8.4	Electronics Block L 32 DO DC 24 V/0.5 A – 6ES7132-1BL00-0XB0	8-11
8.5	Electronics Block L 16 DI/16 DO DC 24 V/0.5 A – 6ES7133-1BL01-0XB0	8-14

8.1 Electronics Block L 16 DI DC 24 V – 6ES7131-1BH01-0XB0

Characteristics The L 16 DI DC 24 V electronics block has the following characteristics:

- 16 inputs in two groups, each of eight inputs
- Rated input voltage of 24 V DC
- Suitable for switches and proximity switches (BEROs)

View The following figure shows a view of the electronics block.

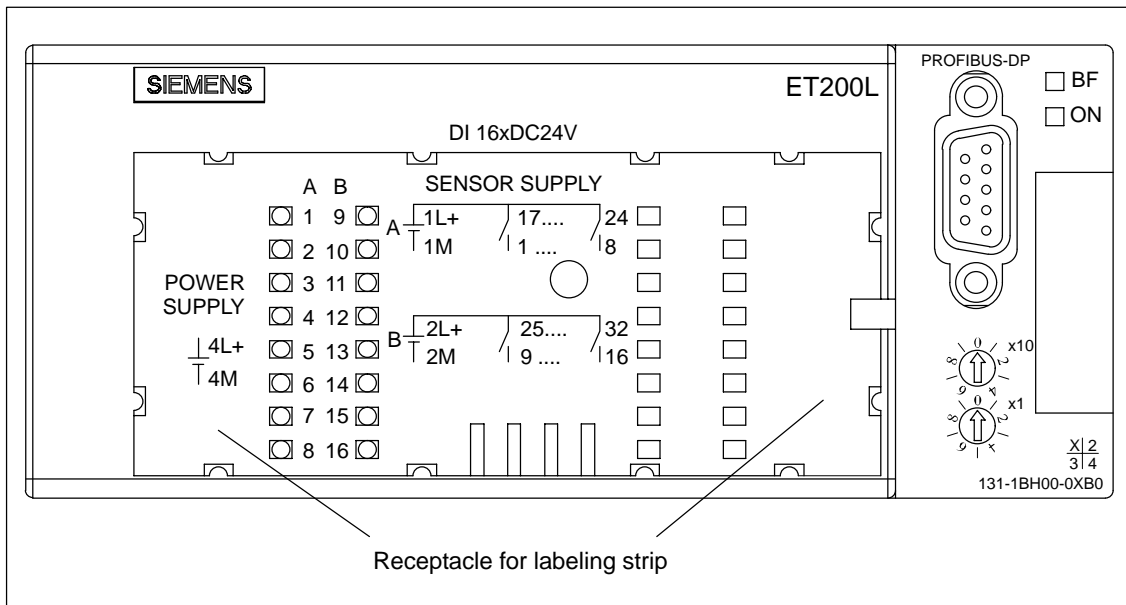

Figure 8-1 View of the L 16 DI DC 24 V Electronics Block

Block Diagram

Figure 8-2 shows the block diagram.

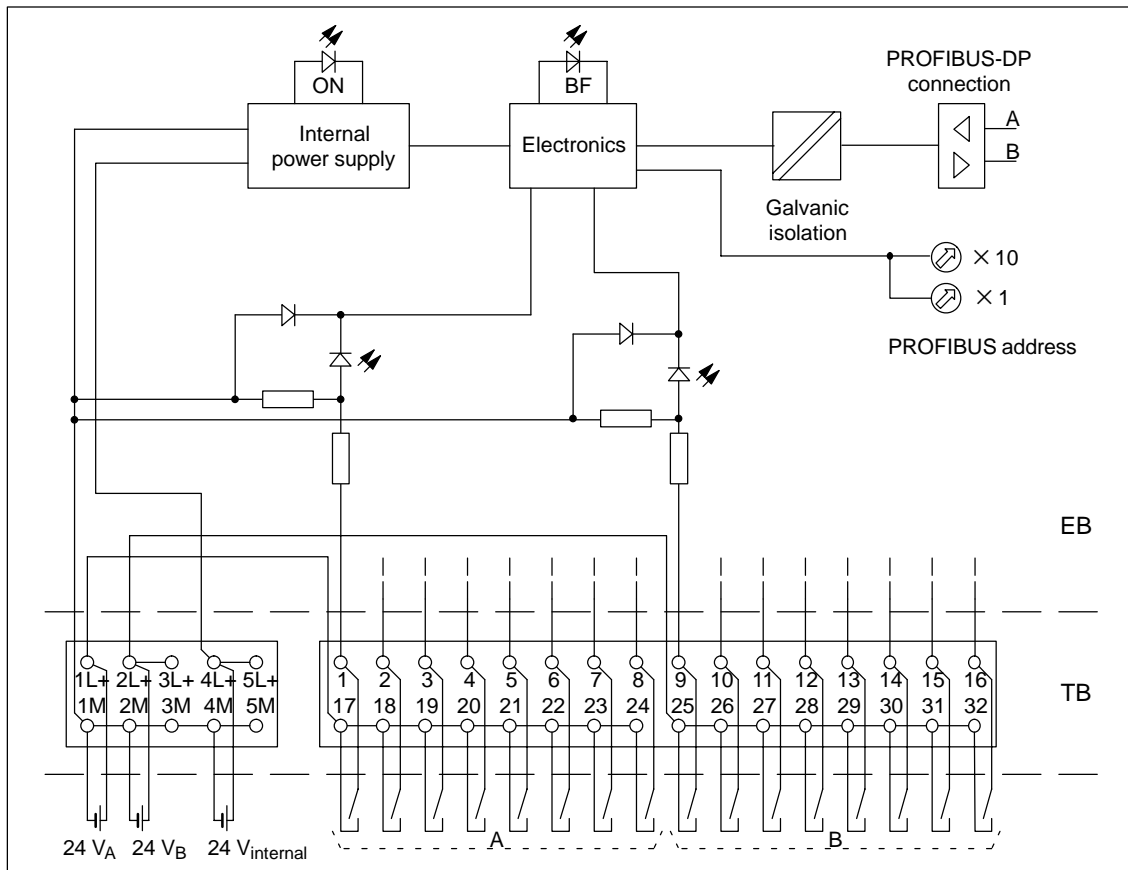

Figure 8-2 Block Diagram of the L 16 DI DC 24 V Electronics Block

Technical Data The following table shows the technical data of the L 16 DI DC 24 V electronics block.

Dimensions and Weight		Status, Interrupts, Diagnostics	
Dimensions W × H × D (mm)	145 × 60 × 60.5	Status display	Green LED per channel
Weight	Approx. 130 g	Interrupts	None
Module-Specific Data		Diagnostic function	Yes
Baud rate	9.6; 19.2; 45,45*;93.75; 187.5; 500 and 1500 kBaud	• Bus monitoring PRO- FIBUS-DP	Red "BF" LED
Bus protocol	PROFIBUS-DP	• Monitoring of elec- tronics power supply	Green "ON" LED
FREEZE compatibility	Yes	Sensor Selection Data	
Number of inputs	16	Input voltage	
Cable length		• Rated value	24 V DC
• Unshielded	Max. 600 m	• At signal "1"	13 to 30 V
• Shielded	Max. 1000 m	• At signal "0"	-30 to 5 V
Manufacturer ID	0014 _H	Input current	
Voltages, Currents, Potentials		• At signal "1"	Typically 5 mA at 24 V
Rated supply voltage for electronics (4L+, 5L+)	24 V DC	Input delay	
• Reverse polarity protection	Yes	• With "0" after "1"	2.0 to 4.5 ms
• Power failure with- stand time	At least 20 ms	• With "1" after "0"	2.0 to 4.5 ms
Rated load voltage (1L+, 2L+ and 3L+)	24 V DC	Input characteristic	To IEC 1131-2 Type 1
Maximum number of in- puts driven simultaneously	16	Connection of 2-wire BEROs	Possible
Galvanic isolation		• Permissible closed-cir- cuit current	Max. 1.5 mA
• Between channels	No		
• Between channels and PROFIBUS-DP	Yes		
Insulation tested with	500 V DC		
Power input			
• From supply voltage L4+/L5+	Max. 70 mA		
• From load voltage L1+ and L2+/L3+ (without load)	Max. 50 mA per load group		
Power loss of module	Typically 2.2 W		

* If you want to run the ET 200L, ET 200L-SC or ET 200L-SC IM-SC at a transmission rate of 45.45 kbps, you must use an updated device master file or STEP 7 as of 4.02 (K4.02.6).

8.2 Electronics Block L 16 DO DC 24 V/0.5 A – 6ES7132-1BH00-0XB0

Characteristics The L 16 DO DC 24 V/0.5 A electronics block has the following characteristics:

- 16 outputs in two groups, each of eight outputs
- Output current of 0.5 A per output
- Rated load voltage of 24 V DC
- Suitable for solenoids, DC contactors, and indicator lights

View The following figure shows a view of the electronics block.

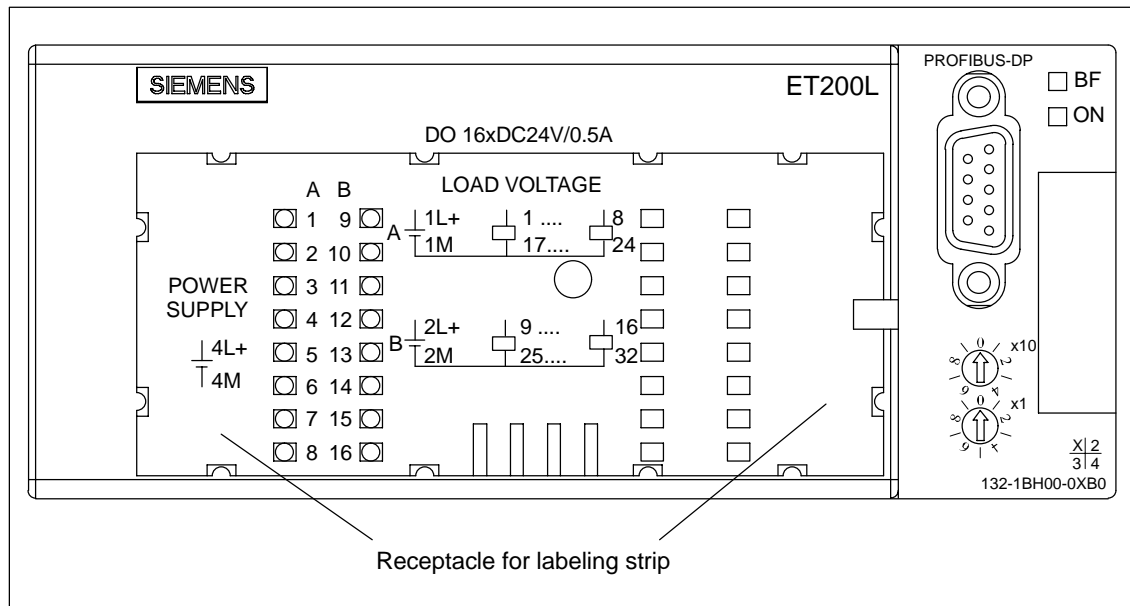

Figure 8-3 View of the L 16 DO DC 24 V/0.5 A Electronics Block

Block Diagram

Figure 8-4 shows the block diagram.

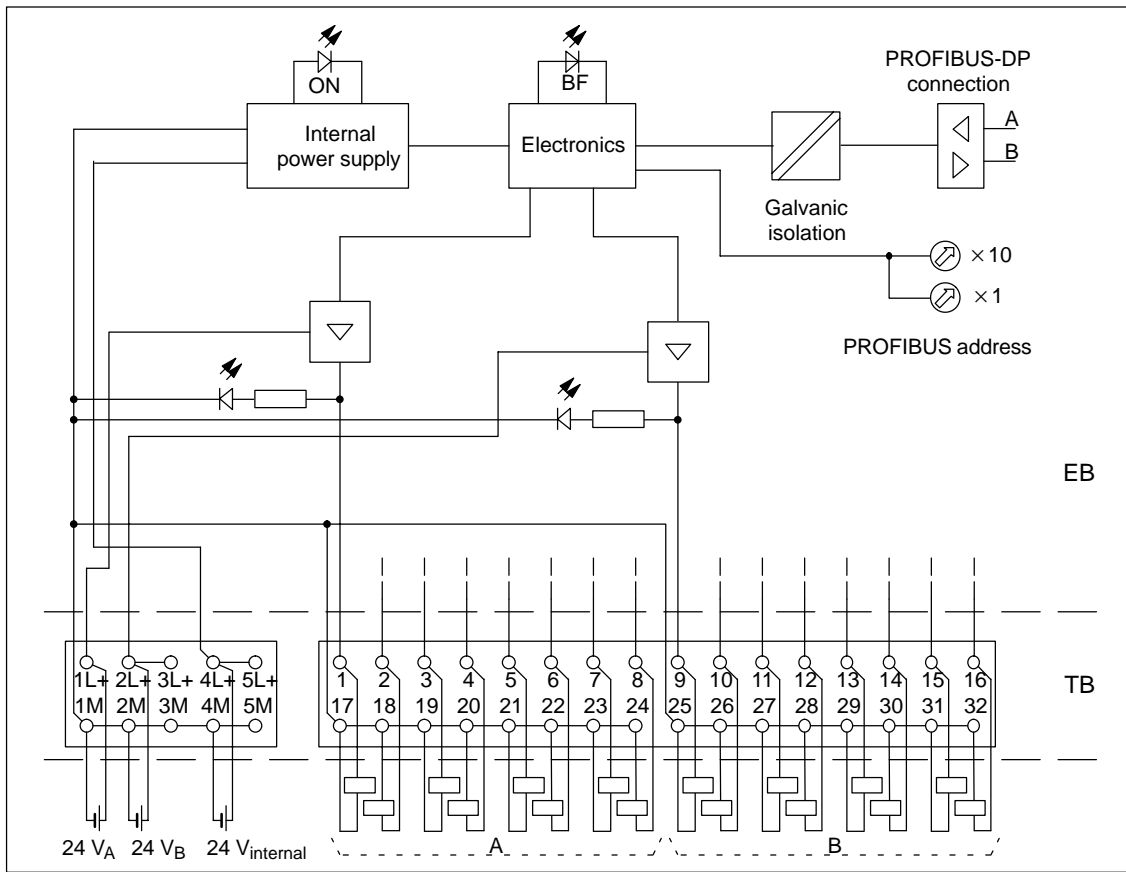

Figure 8-4 Block diagram of the L 16 DO DC 24 V/0.5 A Electronics Block

Technical Data

The following table shows the technical data of the L 16 DO DC 24 V/0.5 A electronics block.

Dimensions and Weight		Cable length	
Dimensions W × H × D (mm)	145 × 60 × 60.5	• Unshielded	Max. 600 m
Weight	Approx. 130 g	• Shielded	Max. 1000 m
Module-Specific Data		Manufacturer ID	0016H
Baud rate	9.6; 19.2; 45,45*; 93.75; 187.5; 500 and 1500 kBaud		
Bus protocol	PROFIBUS-DP		
SYNC compatibility	Yes		
Number of outputs	16		

Voltages, Currents, Potentials		Actuator Selection Data	
Rated supply voltage for electronics (4L+, 5L+)	24 V DC	Output voltage	
• Reverse polarity protection	Yes	• At signal "1"	At least L1+ (– 3 V) or L2+/L3+ (3 V)
• Power failure with-stand time	At least 20 ms	Output current	
Rated load voltage (1L+, 2L+ and 3L+)	24 V DC	• At signal "1"	
Aggregate current of outputs (per byte)		Rated value	0.5 A
• Horizontal installation		Permissible range	1 mA to 0.5 A
Up to 30 °C	Max. 4 A	• At signal "0"	Max. 1 mA
Up to 40 °C	Max. 3 A	(residual current)	
Up to 60 °C	Max. 2 A	Output delay (with resistive load)	
• All other installation positions		• With "0" after "1"	Max. 50 µs
Up to 40 °C	Max. 2 A	• With "1" after "0"	Max. 200 µs
Galvanic isolation		Load resistance range	41 Ω to 28 kΩ
• Between channels	No	Lamp load	Max. 5 W
• Between channels and PROFIBUS-DP	Yes	Parallel connection of two outputs	
Insulation tested with	500 V DC	• For redundant control of load	Possible (outputs in same group only)
Power input		• For performance improvement	Not possible
• from supply voltage L4+/L5+	Max. 70 mA	Driving a digital input	Possible
• from load voltage L1+ and L2+/L3+ (without load)	Max. 50 mA per load group	Switching frequency	
Power loss of module	Typically 5 W	• Resistive load	Max. 100 Hz
		• Inductive load to IEC 947-5-1, DC13	Max. 0.5 Hz
		• Lamp load	Max. 8 Hz
		Limitation of voltage induced on circuit interruption	Typically L1+ (– 55 V) or L2+/L3+ (– 55 V)
		Short-circuit protection	Yes
		• Response threshold	Typically 0.7 A to 1.5 A
Status, Interrupts, Diagnostics			
Status display	Green LED per channel		
Interrupts	None		
Diagnostic function	Yes		
• Bus monitoring PRO-FIBUS-DP	Red "BF" LED		
• Monitoring of electronics power supply	Green "ON" LED		

* If you want to run the ET 200L, ET 200L–SC or ET 200L–SC IM–SC at a transmission rate of 45.45 kbps, you must use an updated device master file or STEP 7 as of 4.02 (K4.02.6).

8.3 Electronics Block L 32 DI DC 24 V 6ES7131-1BL01-0XB0

Characteristics The L 32 DI DC 24 V electronics block has the following characteristics:

- 32 inputs in two groups, each of 16 outputs
- Rated input voltage of 24 V DC
- Suitable for switches and proximity switches (BEROs)

View The following figure shows a view of the electronics block.

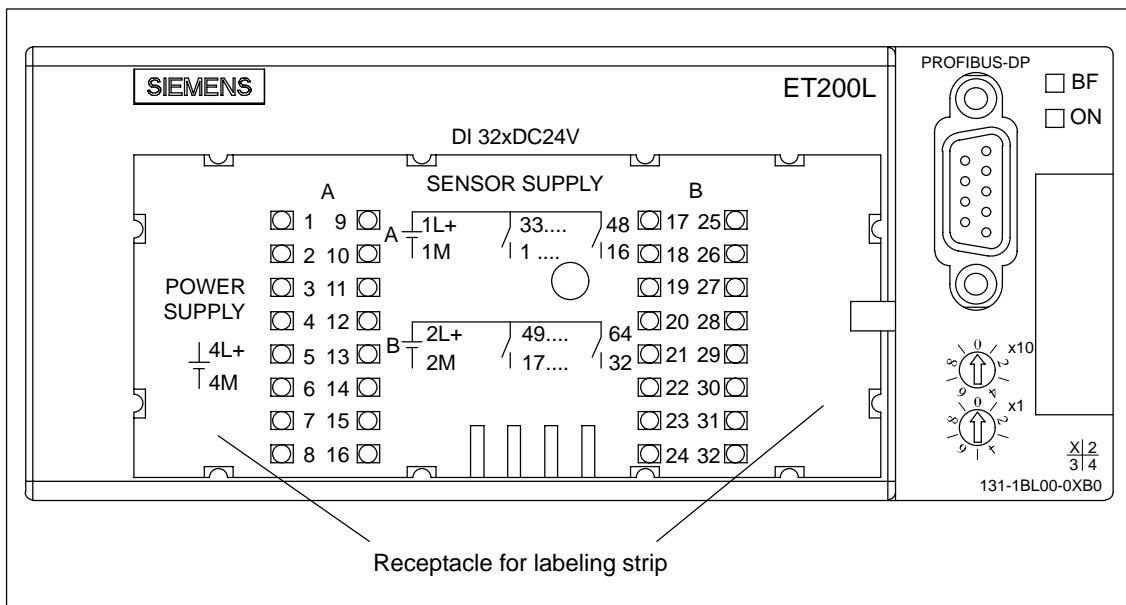

Figure 8-5 View of the L 32 DI DC 24 V Electronics Block

Block Diagram

Figure 8-6 shows the block diagram.

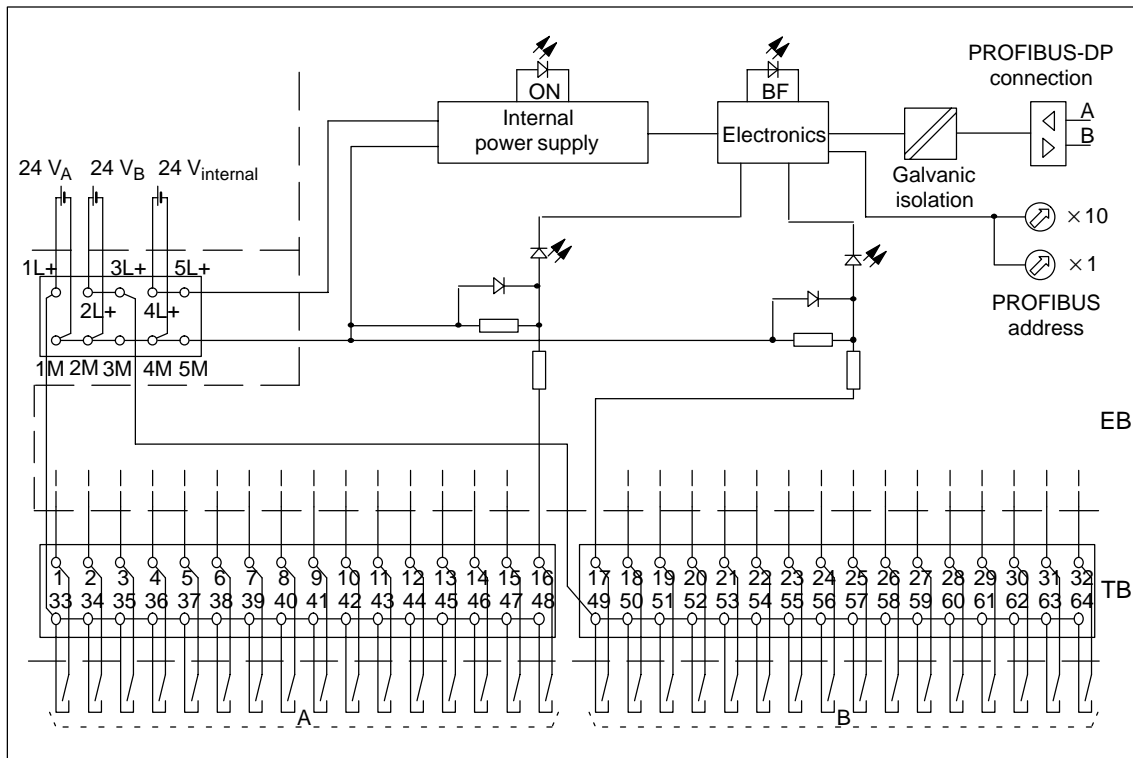

Figure 8-6 Block diagram of the L 32 DI DC 24 V Electronics Block

Technical Data

The following table shows the technical data of the L 32 DI DC 24 V electronics block.

Dimensions and Weight		Status, Interrupts, Diagnostics	
Dimensions W × H × D (mm)	145 × 60 × 60.5	Status display	Green LED per channel
Weight	Approx. 150 g	Interrupts	None
Module-Specific Data		Diagnostic function	Yes
Baud rate	9.6; 19.2; 45,45*; 93.75; 187.5; 500 and 1500 kBaud	• Bus monitoring PRO- FIBUS-DP	Red "BF" LED
Bus protocol	PROFIBUS-DP	• Monitoring of elec- tronics power supply	Green "ON" LED
FREEZE compatibility	Yes	Sensor Selection Data	
Number of inputs	32	Input voltage	
Cable length		• Rated value	24 V DC
• Unshielded	Max. 600 m	• At signal "1"	13 to 30 V
• Shielded	Max. 1000 m	• At signal "0"	-30 to 5 V
Manufacturer ID	0015 _H	Input current	
Voltages, Currents, Potentials		• At signal "1"	Typically 5 mA at 24 V
Rated supply voltage for electronics (4L+, 5L+)	24 V DC	Input delay	
• Reverse polarity protection	Yes	• With "0" after "1"	2.0 to 4.5 ms
• Power failure with- stand time	At least 20 ms	• With "1" after "0"	2.0 to 4.5 ms
Rated load voltage (1L+, 2L+ and 3L+)	24 V DC	Input characteristic	To IEC 1131-2 Type 1
Maximum number of in- puts driven simultaneously	32	Connection of 2-wire BEROs	Possible
Galvanic isolation		• Permissible closed-cir- cuit current	Max. 1.5 mA
• Between channels	No		
• Between channels and PROFIBUS-DP	Yes		
Insulation tested with	500 V DC		
Power input			
• from supply voltage L4+/L5+	Max. 70 mA		
• from load voltage L1+ and L2+/L3+ (without load)	Max. 100 mA per load group		
Power loss of module	Typically 3.2 W		

* If you want to run the ET 200L, ET 200L-SC or ET 200L-SC IM-SC at a transmission rate of 45.45 kbps, you must use an updated device master file or STEP 7 as of 4.02 (K4.02.6).

8.4 Electronics Block L 32 DO DC 24 V/0.5 A – 6ES7132-1BL00-0XB0

Characteristics The L 32 DO DC 24 V/0.5 A electronics block has the following characteristics:

- 32 outputs in two groups, each of 16 outputs
- Output current of 0.5 A per output
- Rated load voltage of 24 V DC
- Suitable for solenoids, DC contactors, and indicator lights

View The following figure shows a view of the electronics block.

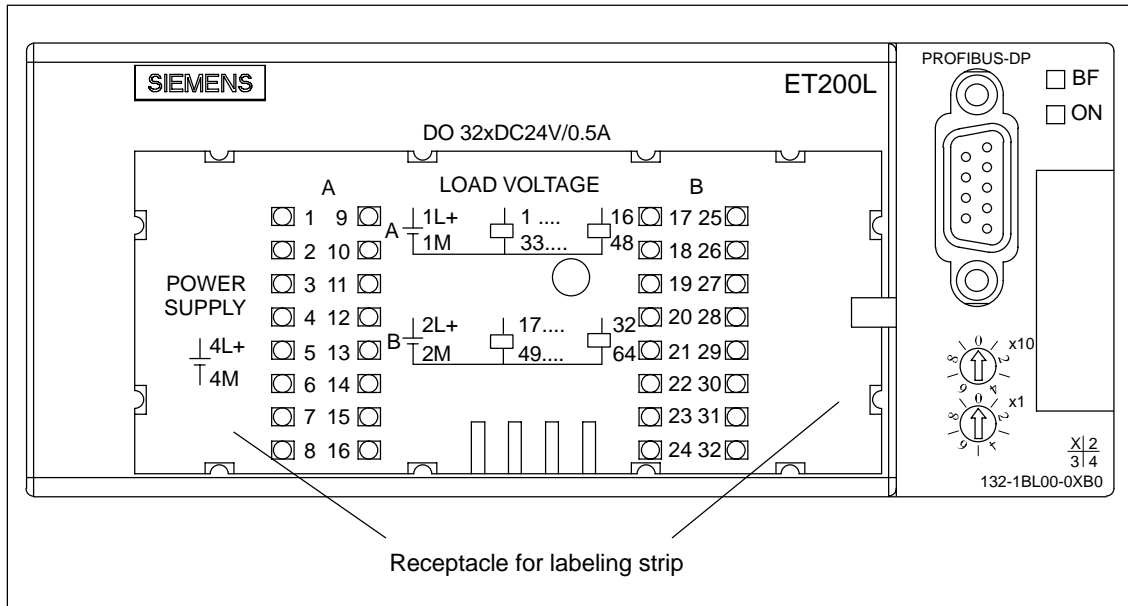

Figure 8-7 View of the L 32 DO Electronics Block DC 24 V/0.5 A

Block Diagram

Figure 8-8 shows the block diagram.

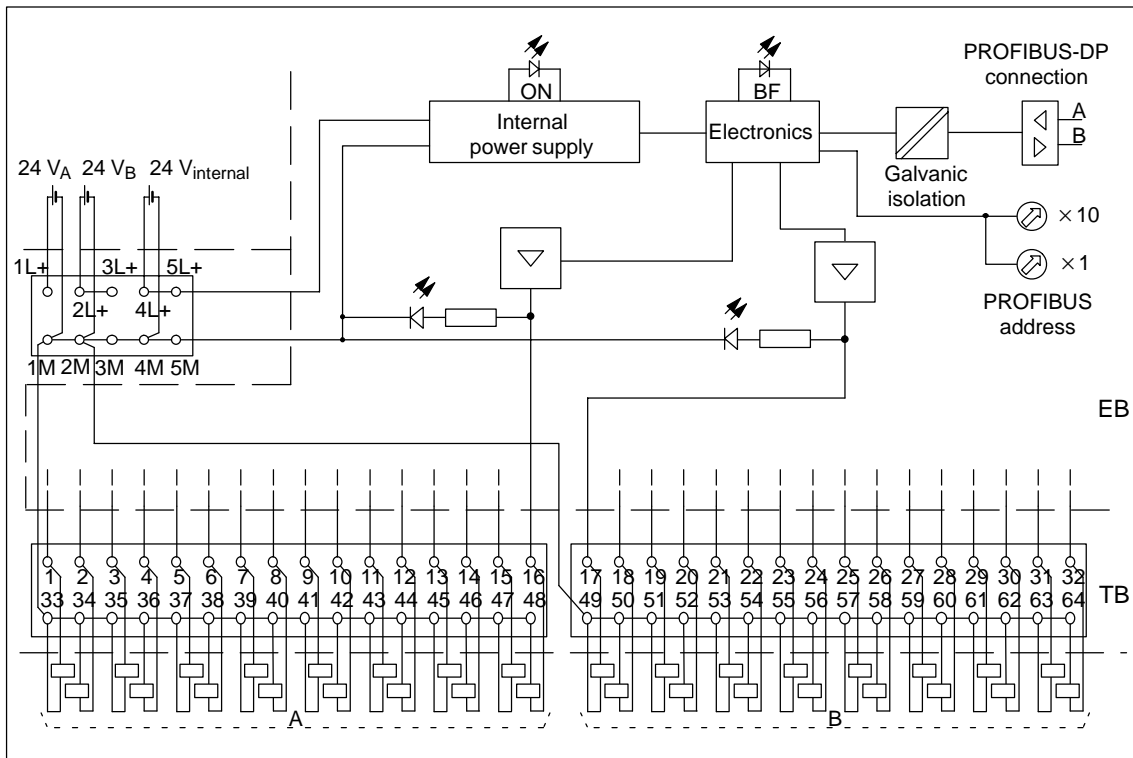

Figure 8-8 Block Diagram of the L 32 DO DC 24 V/0.5 A Electronics Block

Technical data

The following table shows the technical data of the L 32 DO DC 24 V/0.5 A electronics block.

Dimensions and Weight		Voltages, Currents, Potentials	
Dimensions W × H × D (mm)	145 × 60 × 60.5	Rated supply voltage for electronics (4L+, 5L+)	24 V DC
Weight	Approx. 150 g	<ul style="list-style-type: none"> Reverse polarity protection 	Yes
Module-Specific Data		<ul style="list-style-type: none"> Power failure with-stand time 	At least 20 ms
Baud rate	9.6; 19.2; 45.45*; 93.75; 187.5; 500 and 1500 kBaud	Rated load voltage (1L+, 2L+ and 3L+)	24 V DC
Bus protocol	PROFIBUS-DP	Aggregate current of outputs (per byte)	
SYNC compatibility	Yes	<ul style="list-style-type: none"> Horizontal installation 	
Number of outputs	32	Up to 30 °C	Max. 4 A
Cable length		Up to 40 °C	Max. 3 A
<ul style="list-style-type: none"> Unshielded Shielded 	<ul style="list-style-type: none"> Max. 600 m Max. 1000 m 	Up to 60 °C	Max. 2 A
Manufacturer ID	0011 _H	<ul style="list-style-type: none"> All other installation positions 	
		Up to 40 °C	Max. 2 A

Galvanic isolation		Actuator Selection Data	
<ul style="list-style-type: none"> • Between channels No • Between channels and PROFIBUS-DP Yes 		Output voltage	
Insulation tested with	500 V DC	<ul style="list-style-type: none"> • At signal "1" At least L1+ (– 3 V) or L2+/L3+ (3 V) 	
Power input		Output current	
<ul style="list-style-type: none"> • from supply voltage L4+/L5+ Max. 70 mA • from load voltage L1+ and L2+/L3+ (without load) Max. 100 mA per load group 		<ul style="list-style-type: none"> • At signal "1" Rated value 0.5 A • At signal "0" (residual current) Permissible range 1 mA to 0.5 A 	
Power loss of module	Typically 7 W	Output delay (with resistive load)	
Status, Interrupts, Diagnostics		<ul style="list-style-type: none"> • With "0" after "1" Max. 50 µs • With "1" after "0" Max. 200 µs 	
Status display	Green LED per channel	Load resistance range	41 Ω to 28 kΩ
Interrupts	None	Lamp load	Max. 5 W
Diagnostic function	Yes	Parallel connection of two outputs	
<ul style="list-style-type: none"> • Bus monitoring PRO-FIBUS-DP Red "BF" LED • Monitoring of electronics power supply Green "ON" LED 		<ul style="list-style-type: none"> • For redundant control of load Possible (outputs in same group only) • For performance improvement Not possible 	
		Driving a digital input	Possible
		Switching frequency	
		<ul style="list-style-type: none"> • Resistive load Max. 100 Hz • Inductive load to IEC 947-5-1, DC13 Max. 0.5 Hz • Lamp load Max. 8 Hz 	
		Limitation of voltage induced on circuit interruption	Typically L1+ (– 55 V) or L2+/L3+ (55 V)
		Short-circuit protection	Yes
		<ul style="list-style-type: none"> • Response threshold Typically 0.7 A to 1.5 A 	

* If you want to run the ET 200L, ET 200L–SC or ET 200L–SC IM–SC at a transmission rate of 45.45 kbps, you must use an updated device master file or STEP 7 as of 4.02 (K4.02.6).

8.5 Electronics Block L 16 DI/16 DO DC 24 V/0.5 A – 6ES7133-1BL01-0XB0

Characteristics

The L 16 DI/16 DO DC 24 V/0.5 A electronics block has the following characteristics:

- 16 inputs in a single group of 16 inputs
 - Rated input voltage of 24 V DC
 - Suitable for switches and proximity switches (BEROs)
- 16 outputs in a single group of 16 outputs
 - Output current of 0.5 A
 - Rated load voltage of 24 V DC
 - Suitable for solenoids, DC contactors, and indicator lights

View

The following figure shows a view of the electronics block.

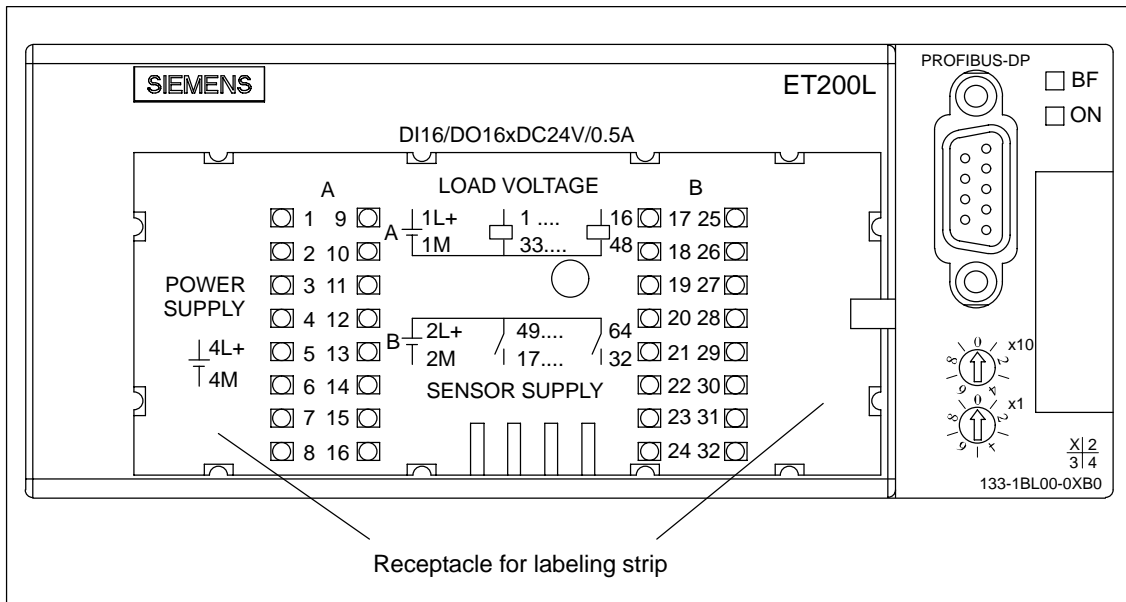

Figure 8-9 View of the L 16 DI/16 DO DC 24 V/0.5 A Electronics Block

Block Diagram

Figure 8-10 shows the block diagram.

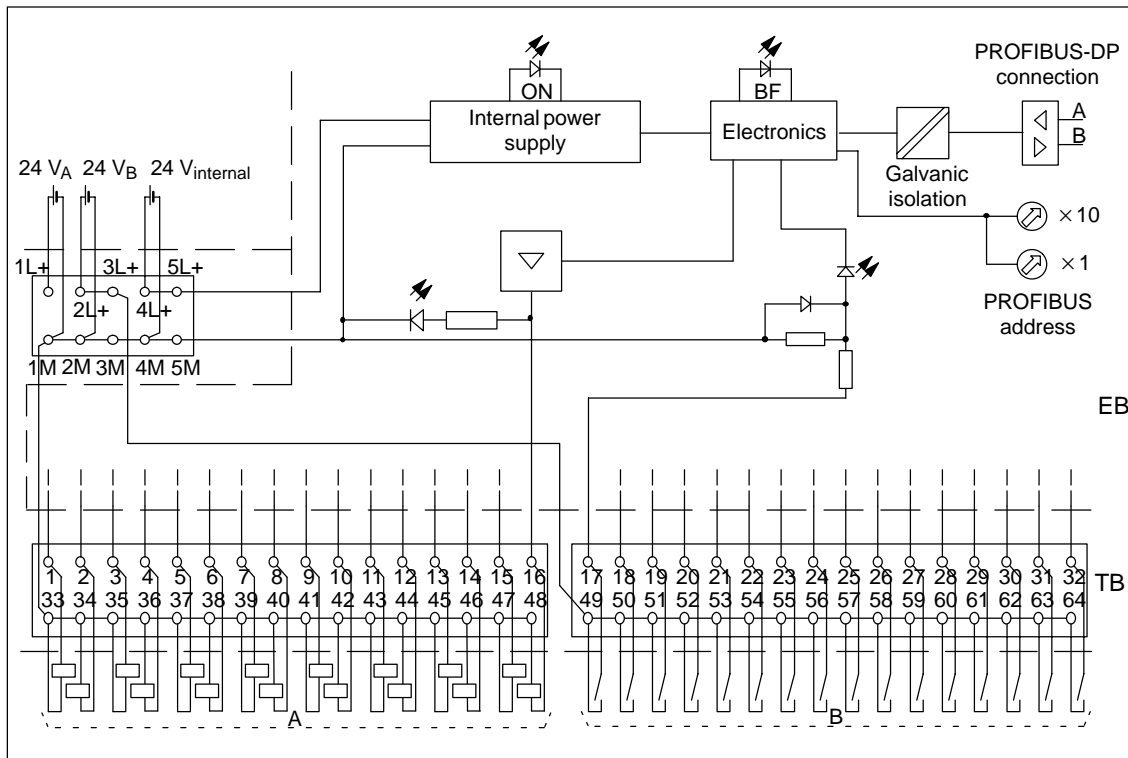

Figure 8-10 Block Diagram of the L 16 DI/16 DO DC 24 V/0.5 A Electronics Block

Technical Data

The following table shows the technical data of the L 16 DI/16 DO DC 24 V/0.5 A electronics block.

Dimensions and Weight		Cable length	
Dimensions W × H × D (mm)	145 × 60 × 60.5	• Unshielded	Max. 600 m
Weight	Approx. 130 g	• Shielded	Max. 1000 m
Module-Specific Data		Manufacturer ID	0017H
Baud rate	9.6; 19.2; 45,45*; 93.75; 187.5; 500 and 1500 kBaud	Voltages, Currents, Potentials	
Bus protocol	PROFIBUS-DP	Rated supply voltage for electronics (4L+, 5L+)	24 V DC
FREEZE compatibility	Yes	• Reverse polarity protection	Yes
SYNC compatibility	Yes	• Power failure with- stand time	At least 20 ms
Number of inputs	16	Rated load voltage (1L+, 2L+ and 3L+)	24 V DC
Number of outputs	16	Maximum number of in- puts driven simultaneously	16

Aggregate current of outputs (per byte)		Input delay	
<ul style="list-style-type: none"> Horizontal installation <ul style="list-style-type: none"> Up to 30 °C Max. 4 A Up to 40 °C Max. 3 A Up to 60 °C Max. 2 A All other installation positions <ul style="list-style-type: none"> Up to 40 °C Max. 2 A 		<ul style="list-style-type: none"> With "0" after "1" 2.0 to 4.5 ms With "1" after "0" 2.0 to 4.5 ms 	
Galvanic isolation		Input characteristic To IEC 1131-2 Type 1	
<ul style="list-style-type: none"> Between channels No Between channels and PROFIBUS-DP Yes 		Connection of 2-wire BEROs Possible	
Insulation tested with 500 V DC		<ul style="list-style-type: none"> Permissible closed-circuit current Max. 1.5 mA 	
Power input		Actuator Selection Data	
<ul style="list-style-type: none"> from supply voltage L4+/L5+ Max. 70 mA from load voltage L1+ and L2+/L3+ (without load) Max. 50 mA per load group 		Output voltage	
Power loss of module Typically 5 W		<ul style="list-style-type: none"> At signal "1" At least L1+ (– 3 V) or L2+/L3+ (3 V) 	
Status, Interrupts, Diagnostics		Output current	
Status display Green LED per channel		<ul style="list-style-type: none"> At signal "1" <ul style="list-style-type: none"> Rated value 0.5 A Permissible range 1 mA to 0.5 A At signal "0" (residual current) Max. 1 mA 	
Interrupts None		Output delay (with resistive load)	
Diagnostic function Yes		<ul style="list-style-type: none"> With "0" after "1" Max. 50 µs With "1" after "0" Max. 200 µs 	
<ul style="list-style-type: none"> Bus monitoring PRO-FIBUS-DP Red "BF" LED Monitoring of electronics power supply Green "ON" LED 		Load resistance range 41 Ω to 28 kΩ	
Sensor Selection Data		Lamp load Max. 5 W	
Input voltage		Parallel connection of two outputs	
<ul style="list-style-type: none"> Rated value 24 V DC At signal "1" 13 to 30 V At signal "0" -30 to 5 V 		<ul style="list-style-type: none"> For redundant control of load Possible (outputs in same group only) For performance improvement Not possible 	
Input current		Driving a digital input Possible	
<ul style="list-style-type: none"> At signal "1" Typically 5 mA at 24 V 		Switching frequency	
		<ul style="list-style-type: none"> Resistive load Max. 100 Hz Inductive load to IEC 947-5-1, DC13 Max. 0.5 Hz Lamp load Max. 8 Hz 	
		Limitation of voltage induced on circuit interruption Typically L1+ (– 55 V) or L2+/L3+ (– 55 V)	
		Short-circuit protection Yes	
		<ul style="list-style-type: none"> Response threshold Typically 0.7 A to 1.5 A 	

* If you want to run the ET 200L, ET 200L–SC or ET 200L–SC IM–SC at a transmission rate of 45.45 kbps, you must use an updated device master file or STEP 7 as of 4.02 (K4.02.6).

Order Numbers

A

Introduction

Should you require additional components for the ET 200L distributed I/O device or should you wish to upgrade the PROFIBUS, you will find the order numbers here for the corresponding components.

We have divided the components into:

- ET 200L components
- Accessories for the PROFIBUS with a note on the manuals for the different PROFIBUS-DP masters and system configuration software

Contents of the Appendix

Section	Subject	Page
A.1	Order Numbers for ET 200L Components	A-2
A.2	Order Numbers for PROFIBUS Accessories	A-5

A.1 Order Numbers for ET 200L Components

Introduction You will find here the order numbers for ET 200L components.

Terminal Blocks Table A-1 Terminal Block Order Numbers

Description	Order Number
Terminal block TB 16L, screw-type terminal	6ES7193-1CH00-0XA0
Terminal block TB 16L, spring terminal	6ES7193-1CH10-0XA0
Terminal block TB 32L, screw-type terminal	6ES7193-1CL00-0XA0
Terminal block TB 32L, spring terminal	6ES7193-1CL10-0XA0

Electronics Blocks Table A-2 Electronics Block Order Numbers

Description	Order Number
L 16 DI DC 24 V	6ES7131-1BH01-0XB0
L 32 DI DC 24 V	6ES7131-1BL01-0XB0
L 16 DO DC 24 V/0.5 A	6ES7132-1BH00-0XB0
L 32 DO DC 24 V/0.5 A	6ES7132-1BL00-0XB0
L 16 DI/16 DO DC 24 V/0.5 A	6ES7133-1BL01-0XB0

Supplementary Terminal Table A-3 Supplementary Terminal Order Numbers

Description	Order Number
Single-tier, 16 channels, screw-type terminal	6ES7193-1FH20-0XA0
Two-tier, 16 channels, screw-type terminal	6ES7193-1FH30-0XA0
Single-tier, 16 channels, spring terminal	6ES7193-1FH50-0XA0
Two-tier, 16 channels, spring terminal	6ES7193-1FH60-0XA0
Single-tier, 32 channels, screw-type terminal	6ES7193-1FL20-0XA0
Two-tier, 32 channels, screw-type terminal	6ES7193-1FL30-0XA0
Single-tier, 32 channels, spring terminal	6ES7193-1FL50-0XA0
Two-tier, 32 channels, spring terminal	6ES7193-1FL60-0XA0

Labeling Strips You obtain additional labeling strips by quoting the following order number:

- 10 x 10 strips for ET 200L, 16 channels: 6ES7193-1BH10-0XA0
- 10 x 10 strips for ET 200L, 32 channels: 6ES7193-1BL10-0XA0

<p>ET 200L Labeling strips 16 channels</p> <table style="width: 100%; border-collapse: collapse;"> <tr><td style="text-align: center;">A B</td></tr> <tr><td><input type="checkbox"/> 1 9 <input type="checkbox"/></td></tr> <tr><td><input type="checkbox"/> 2 10 <input type="checkbox"/></td></tr> <tr><td><input type="checkbox"/> 3 11 <input type="checkbox"/></td></tr> <tr><td><input type="checkbox"/> 4 12 <input type="checkbox"/></td></tr> <tr><td><input type="checkbox"/> 5 13 <input type="checkbox"/></td></tr> <tr><td><input type="checkbox"/> 6 14 <input type="checkbox"/></td></tr> <tr><td><input type="checkbox"/> 7 15 <input type="checkbox"/></td></tr> <tr><td><input type="checkbox"/> 8 16 <input type="checkbox"/></td></tr> </table>	A B	<input type="checkbox"/> 1 9 <input type="checkbox"/>	<input type="checkbox"/> 2 10 <input type="checkbox"/>	<input type="checkbox"/> 3 11 <input type="checkbox"/>	<input type="checkbox"/> 4 12 <input type="checkbox"/>	<input type="checkbox"/> 5 13 <input type="checkbox"/>	<input type="checkbox"/> 6 14 <input type="checkbox"/>	<input type="checkbox"/> 7 15 <input type="checkbox"/>	<input type="checkbox"/> 8 16 <input type="checkbox"/>	<p>2NET - 7810022 6ES7 - 193 - IBH00 - 0XA0</p> <table style="width: 100%; border-collapse: collapse;"> <tr><td style="text-align: center;">A B</td></tr> <tr><td><input type="checkbox"/> 1 9 <input type="checkbox"/></td></tr> <tr><td><input type="checkbox"/> 2 10 <input type="checkbox"/></td></tr> <tr><td><input type="checkbox"/> 3 11 <input type="checkbox"/></td></tr> <tr><td><input type="checkbox"/> 4 12 <input type="checkbox"/></td></tr> <tr><td><input type="checkbox"/> 5 13 <input type="checkbox"/></td></tr> <tr><td><input type="checkbox"/> 6 14 <input type="checkbox"/></td></tr> <tr><td><input type="checkbox"/> 7 15 <input type="checkbox"/></td></tr> <tr><td><input type="checkbox"/> 8 16 <input type="checkbox"/></td></tr> </table>	A B	<input type="checkbox"/> 1 9 <input type="checkbox"/>	<input type="checkbox"/> 2 10 <input type="checkbox"/>	<input type="checkbox"/> 3 11 <input type="checkbox"/>	<input type="checkbox"/> 4 12 <input type="checkbox"/>	<input type="checkbox"/> 5 13 <input type="checkbox"/>	<input type="checkbox"/> 6 14 <input type="checkbox"/>	<input type="checkbox"/> 7 15 <input type="checkbox"/>	<input type="checkbox"/> 8 16 <input type="checkbox"/>
A B																			
<input type="checkbox"/> 1 9 <input type="checkbox"/>																			
<input type="checkbox"/> 2 10 <input type="checkbox"/>																			
<input type="checkbox"/> 3 11 <input type="checkbox"/>																			
<input type="checkbox"/> 4 12 <input type="checkbox"/>																			
<input type="checkbox"/> 5 13 <input type="checkbox"/>																			
<input type="checkbox"/> 6 14 <input type="checkbox"/>																			
<input type="checkbox"/> 7 15 <input type="checkbox"/>																			
<input type="checkbox"/> 8 16 <input type="checkbox"/>																			
A B																			
<input type="checkbox"/> 1 9 <input type="checkbox"/>																			
<input type="checkbox"/> 2 10 <input type="checkbox"/>																			
<input type="checkbox"/> 3 11 <input type="checkbox"/>																			
<input type="checkbox"/> 4 12 <input type="checkbox"/>																			
<input type="checkbox"/> 5 13 <input type="checkbox"/>																			
<input type="checkbox"/> 6 14 <input type="checkbox"/>																			
<input type="checkbox"/> 7 15 <input type="checkbox"/>																			
<input type="checkbox"/> 8 16 <input type="checkbox"/>																			
<table style="width: 100%; border-collapse: collapse;"> <tr><td style="text-align: center;">A B</td></tr> <tr><td><input type="checkbox"/> 1 9 <input type="checkbox"/></td></tr> <tr><td><input type="checkbox"/> 2 10 <input type="checkbox"/></td></tr> <tr><td><input type="checkbox"/> 3 11 <input type="checkbox"/></td></tr> <tr><td><input type="checkbox"/> 4 12 <input type="checkbox"/></td></tr> <tr><td><input type="checkbox"/> 5 13 <input type="checkbox"/></td></tr> <tr><td><input type="checkbox"/> 6 14 <input type="checkbox"/></td></tr> <tr><td><input type="checkbox"/> 7 15 <input type="checkbox"/></td></tr> <tr><td><input type="checkbox"/> 8 16 <input type="checkbox"/></td></tr> </table>	A B	<input type="checkbox"/> 1 9 <input type="checkbox"/>	<input type="checkbox"/> 2 10 <input type="checkbox"/>	<input type="checkbox"/> 3 11 <input type="checkbox"/>	<input type="checkbox"/> 4 12 <input type="checkbox"/>	<input type="checkbox"/> 5 13 <input type="checkbox"/>	<input type="checkbox"/> 6 14 <input type="checkbox"/>	<input type="checkbox"/> 7 15 <input type="checkbox"/>	<input type="checkbox"/> 8 16 <input type="checkbox"/>	<table style="width: 100%; border-collapse: collapse;"> <tr><td style="text-align: center;">A B</td></tr> <tr><td><input type="checkbox"/> 1 9 <input type="checkbox"/></td></tr> <tr><td><input type="checkbox"/> 2 10 <input type="checkbox"/></td></tr> <tr><td><input type="checkbox"/> 3 11 <input type="checkbox"/></td></tr> <tr><td><input type="checkbox"/> 4 12 <input type="checkbox"/></td></tr> <tr><td><input type="checkbox"/> 5 13 <input type="checkbox"/></td></tr> <tr><td><input type="checkbox"/> 6 14 <input type="checkbox"/></td></tr> <tr><td><input type="checkbox"/> 7 15 <input type="checkbox"/></td></tr> <tr><td><input type="checkbox"/> 8 16 <input type="checkbox"/></td></tr> </table>	A B	<input type="checkbox"/> 1 9 <input type="checkbox"/>	<input type="checkbox"/> 2 10 <input type="checkbox"/>	<input type="checkbox"/> 3 11 <input type="checkbox"/>	<input type="checkbox"/> 4 12 <input type="checkbox"/>	<input type="checkbox"/> 5 13 <input type="checkbox"/>	<input type="checkbox"/> 6 14 <input type="checkbox"/>	<input type="checkbox"/> 7 15 <input type="checkbox"/>	<input type="checkbox"/> 8 16 <input type="checkbox"/>
A B																			
<input type="checkbox"/> 1 9 <input type="checkbox"/>																			
<input type="checkbox"/> 2 10 <input type="checkbox"/>																			
<input type="checkbox"/> 3 11 <input type="checkbox"/>																			
<input type="checkbox"/> 4 12 <input type="checkbox"/>																			
<input type="checkbox"/> 5 13 <input type="checkbox"/>																			
<input type="checkbox"/> 6 14 <input type="checkbox"/>																			
<input type="checkbox"/> 7 15 <input type="checkbox"/>																			
<input type="checkbox"/> 8 16 <input type="checkbox"/>																			
A B																			
<input type="checkbox"/> 1 9 <input type="checkbox"/>																			
<input type="checkbox"/> 2 10 <input type="checkbox"/>																			
<input type="checkbox"/> 3 11 <input type="checkbox"/>																			
<input type="checkbox"/> 4 12 <input type="checkbox"/>																			
<input type="checkbox"/> 5 13 <input type="checkbox"/>																			
<input type="checkbox"/> 6 14 <input type="checkbox"/>																			
<input type="checkbox"/> 7 15 <input type="checkbox"/>																			
<input type="checkbox"/> 8 16 <input type="checkbox"/>																			
<table style="width: 100%; border-collapse: collapse;"> <tr><td style="text-align: center;">A B</td></tr> <tr><td><input type="checkbox"/> 1 9 <input type="checkbox"/></td></tr> <tr><td><input type="checkbox"/> 2 10 <input type="checkbox"/></td></tr> <tr><td><input type="checkbox"/> 3 11 <input type="checkbox"/></td></tr> <tr><td><input type="checkbox"/> 4 12 <input type="checkbox"/></td></tr> <tr><td><input type="checkbox"/> 5 13 <input type="checkbox"/></td></tr> <tr><td><input type="checkbox"/> 6 14 <input type="checkbox"/></td></tr> <tr><td><input type="checkbox"/> 7 15 <input type="checkbox"/></td></tr> <tr><td><input type="checkbox"/> 8 16 <input type="checkbox"/></td></tr> </table>	A B	<input type="checkbox"/> 1 9 <input type="checkbox"/>	<input type="checkbox"/> 2 10 <input type="checkbox"/>	<input type="checkbox"/> 3 11 <input type="checkbox"/>	<input type="checkbox"/> 4 12 <input type="checkbox"/>	<input type="checkbox"/> 5 13 <input type="checkbox"/>	<input type="checkbox"/> 6 14 <input type="checkbox"/>	<input type="checkbox"/> 7 15 <input type="checkbox"/>	<input type="checkbox"/> 8 16 <input type="checkbox"/>	<table style="width: 100%; border-collapse: collapse;"> <tr><td style="text-align: center;">A B</td></tr> <tr><td><input type="checkbox"/> 1 9 <input type="checkbox"/></td></tr> <tr><td><input type="checkbox"/> 2 10 <input type="checkbox"/></td></tr> <tr><td><input type="checkbox"/> 3 11 <input type="checkbox"/></td></tr> <tr><td><input type="checkbox"/> 4 12 <input type="checkbox"/></td></tr> <tr><td><input type="checkbox"/> 5 13 <input type="checkbox"/></td></tr> <tr><td><input type="checkbox"/> 6 14 <input type="checkbox"/></td></tr> <tr><td><input type="checkbox"/> 7 15 <input type="checkbox"/></td></tr> <tr><td><input type="checkbox"/> 8 16 <input type="checkbox"/></td></tr> </table>	A B	<input type="checkbox"/> 1 9 <input type="checkbox"/>	<input type="checkbox"/> 2 10 <input type="checkbox"/>	<input type="checkbox"/> 3 11 <input type="checkbox"/>	<input type="checkbox"/> 4 12 <input type="checkbox"/>	<input type="checkbox"/> 5 13 <input type="checkbox"/>	<input type="checkbox"/> 6 14 <input type="checkbox"/>	<input type="checkbox"/> 7 15 <input type="checkbox"/>	<input type="checkbox"/> 8 16 <input type="checkbox"/>
A B																			
<input type="checkbox"/> 1 9 <input type="checkbox"/>																			
<input type="checkbox"/> 2 10 <input type="checkbox"/>																			
<input type="checkbox"/> 3 11 <input type="checkbox"/>																			
<input type="checkbox"/> 4 12 <input type="checkbox"/>																			
<input type="checkbox"/> 5 13 <input type="checkbox"/>																			
<input type="checkbox"/> 6 14 <input type="checkbox"/>																			
<input type="checkbox"/> 7 15 <input type="checkbox"/>																			
<input type="checkbox"/> 8 16 <input type="checkbox"/>																			
A B																			
<input type="checkbox"/> 1 9 <input type="checkbox"/>																			
<input type="checkbox"/> 2 10 <input type="checkbox"/>																			
<input type="checkbox"/> 3 11 <input type="checkbox"/>																			
<input type="checkbox"/> 4 12 <input type="checkbox"/>																			
<input type="checkbox"/> 5 13 <input type="checkbox"/>																			
<input type="checkbox"/> 6 14 <input type="checkbox"/>																			
<input type="checkbox"/> 7 15 <input type="checkbox"/>																			
<input type="checkbox"/> 8 16 <input type="checkbox"/>																			
<table style="width: 100%; border-collapse: collapse;"> <tr><td style="text-align: center;">A B</td></tr> <tr><td><input type="checkbox"/> 1 9 <input type="checkbox"/></td></tr> <tr><td><input type="checkbox"/> 2 10 <input type="checkbox"/></td></tr> <tr><td><input type="checkbox"/> 3 11 <input type="checkbox"/></td></tr> <tr><td><input type="checkbox"/> 4 12 <input type="checkbox"/></td></tr> <tr><td><input type="checkbox"/> 5 13 <input type="checkbox"/></td></tr> <tr><td><input type="checkbox"/> 6 14 <input type="checkbox"/></td></tr> <tr><td><input type="checkbox"/> 7 15 <input type="checkbox"/></td></tr> <tr><td><input type="checkbox"/> 8 16 <input type="checkbox"/></td></tr> </table>	A B	<input type="checkbox"/> 1 9 <input type="checkbox"/>	<input type="checkbox"/> 2 10 <input type="checkbox"/>	<input type="checkbox"/> 3 11 <input type="checkbox"/>	<input type="checkbox"/> 4 12 <input type="checkbox"/>	<input type="checkbox"/> 5 13 <input type="checkbox"/>	<input type="checkbox"/> 6 14 <input type="checkbox"/>	<input type="checkbox"/> 7 15 <input type="checkbox"/>	<input type="checkbox"/> 8 16 <input type="checkbox"/>	<table style="width: 100%; border-collapse: collapse;"> <tr><td style="text-align: center;">A B</td></tr> <tr><td><input type="checkbox"/> 1 9 <input type="checkbox"/></td></tr> <tr><td><input type="checkbox"/> 2 10 <input type="checkbox"/></td></tr> <tr><td><input type="checkbox"/> 3 11 <input type="checkbox"/></td></tr> <tr><td><input type="checkbox"/> 4 12 <input type="checkbox"/></td></tr> <tr><td><input type="checkbox"/> 5 13 <input type="checkbox"/></td></tr> <tr><td><input type="checkbox"/> 6 14 <input type="checkbox"/></td></tr> <tr><td><input type="checkbox"/> 7 15 <input type="checkbox"/></td></tr> <tr><td><input type="checkbox"/> 8 16 <input type="checkbox"/></td></tr> </table>	A B	<input type="checkbox"/> 1 9 <input type="checkbox"/>	<input type="checkbox"/> 2 10 <input type="checkbox"/>	<input type="checkbox"/> 3 11 <input type="checkbox"/>	<input type="checkbox"/> 4 12 <input type="checkbox"/>	<input type="checkbox"/> 5 13 <input type="checkbox"/>	<input type="checkbox"/> 6 14 <input type="checkbox"/>	<input type="checkbox"/> 7 15 <input type="checkbox"/>	<input type="checkbox"/> 8 16 <input type="checkbox"/>
A B																			
<input type="checkbox"/> 1 9 <input type="checkbox"/>																			
<input type="checkbox"/> 2 10 <input type="checkbox"/>																			
<input type="checkbox"/> 3 11 <input type="checkbox"/>																			
<input type="checkbox"/> 4 12 <input type="checkbox"/>																			
<input type="checkbox"/> 5 13 <input type="checkbox"/>																			
<input type="checkbox"/> 6 14 <input type="checkbox"/>																			
<input type="checkbox"/> 7 15 <input type="checkbox"/>																			
<input type="checkbox"/> 8 16 <input type="checkbox"/>																			
A B																			
<input type="checkbox"/> 1 9 <input type="checkbox"/>																			
<input type="checkbox"/> 2 10 <input type="checkbox"/>																			
<input type="checkbox"/> 3 11 <input type="checkbox"/>																			
<input type="checkbox"/> 4 12 <input type="checkbox"/>																			
<input type="checkbox"/> 5 13 <input type="checkbox"/>																			
<input type="checkbox"/> 6 14 <input type="checkbox"/>																			
<input type="checkbox"/> 7 15 <input type="checkbox"/>																			
<input type="checkbox"/> 8 16 <input type="checkbox"/>																			
<table style="width: 100%; border-collapse: collapse;"> <tr><td style="text-align: center;">A B</td></tr> <tr><td><input type="checkbox"/> 1 9 <input type="checkbox"/></td></tr> <tr><td><input type="checkbox"/> 2 10 <input type="checkbox"/></td></tr> <tr><td><input type="checkbox"/> 3 11 <input type="checkbox"/></td></tr> <tr><td><input type="checkbox"/> 4 12 <input type="checkbox"/></td></tr> <tr><td><input type="checkbox"/> 5 13 <input type="checkbox"/></td></tr> <tr><td><input type="checkbox"/> 6 14 <input type="checkbox"/></td></tr> <tr><td><input type="checkbox"/> 7 15 <input type="checkbox"/></td></tr> <tr><td><input type="checkbox"/> 8 16 <input type="checkbox"/></td></tr> </table>	A B	<input type="checkbox"/> 1 9 <input type="checkbox"/>	<input type="checkbox"/> 2 10 <input type="checkbox"/>	<input type="checkbox"/> 3 11 <input type="checkbox"/>	<input type="checkbox"/> 4 12 <input type="checkbox"/>	<input type="checkbox"/> 5 13 <input type="checkbox"/>	<input type="checkbox"/> 6 14 <input type="checkbox"/>	<input type="checkbox"/> 7 15 <input type="checkbox"/>	<input type="checkbox"/> 8 16 <input type="checkbox"/>	<table style="width: 100%; border-collapse: collapse;"> <tr><td style="text-align: center;">A B</td></tr> <tr><td><input type="checkbox"/> 1 9 <input type="checkbox"/></td></tr> <tr><td><input type="checkbox"/> 2 10 <input type="checkbox"/></td></tr> <tr><td><input type="checkbox"/> 3 11 <input type="checkbox"/></td></tr> <tr><td><input type="checkbox"/> 4 12 <input type="checkbox"/></td></tr> <tr><td><input type="checkbox"/> 5 13 <input type="checkbox"/></td></tr> <tr><td><input type="checkbox"/> 6 14 <input type="checkbox"/></td></tr> <tr><td><input type="checkbox"/> 7 15 <input type="checkbox"/></td></tr> <tr><td><input type="checkbox"/> 8 16 <input type="checkbox"/></td></tr> </table>	A B	<input type="checkbox"/> 1 9 <input type="checkbox"/>	<input type="checkbox"/> 2 10 <input type="checkbox"/>	<input type="checkbox"/> 3 11 <input type="checkbox"/>	<input type="checkbox"/> 4 12 <input type="checkbox"/>	<input type="checkbox"/> 5 13 <input type="checkbox"/>	<input type="checkbox"/> 6 14 <input type="checkbox"/>	<input type="checkbox"/> 7 15 <input type="checkbox"/>	<input type="checkbox"/> 8 16 <input type="checkbox"/>
A B																			
<input type="checkbox"/> 1 9 <input type="checkbox"/>																			
<input type="checkbox"/> 2 10 <input type="checkbox"/>																			
<input type="checkbox"/> 3 11 <input type="checkbox"/>																			
<input type="checkbox"/> 4 12 <input type="checkbox"/>																			
<input type="checkbox"/> 5 13 <input type="checkbox"/>																			
<input type="checkbox"/> 6 14 <input type="checkbox"/>																			
<input type="checkbox"/> 7 15 <input type="checkbox"/>																			
<input type="checkbox"/> 8 16 <input type="checkbox"/>																			
A B																			
<input type="checkbox"/> 1 9 <input type="checkbox"/>																			
<input type="checkbox"/> 2 10 <input type="checkbox"/>																			
<input type="checkbox"/> 3 11 <input type="checkbox"/>																			
<input type="checkbox"/> 4 12 <input type="checkbox"/>																			
<input type="checkbox"/> 5 13 <input type="checkbox"/>																			
<input type="checkbox"/> 6 14 <input type="checkbox"/>																			
<input type="checkbox"/> 7 15 <input type="checkbox"/>																			
<input type="checkbox"/> 8 16 <input type="checkbox"/>																			

Figure A-1 Labeling Strips 6ES7193-1BH00-0XA0

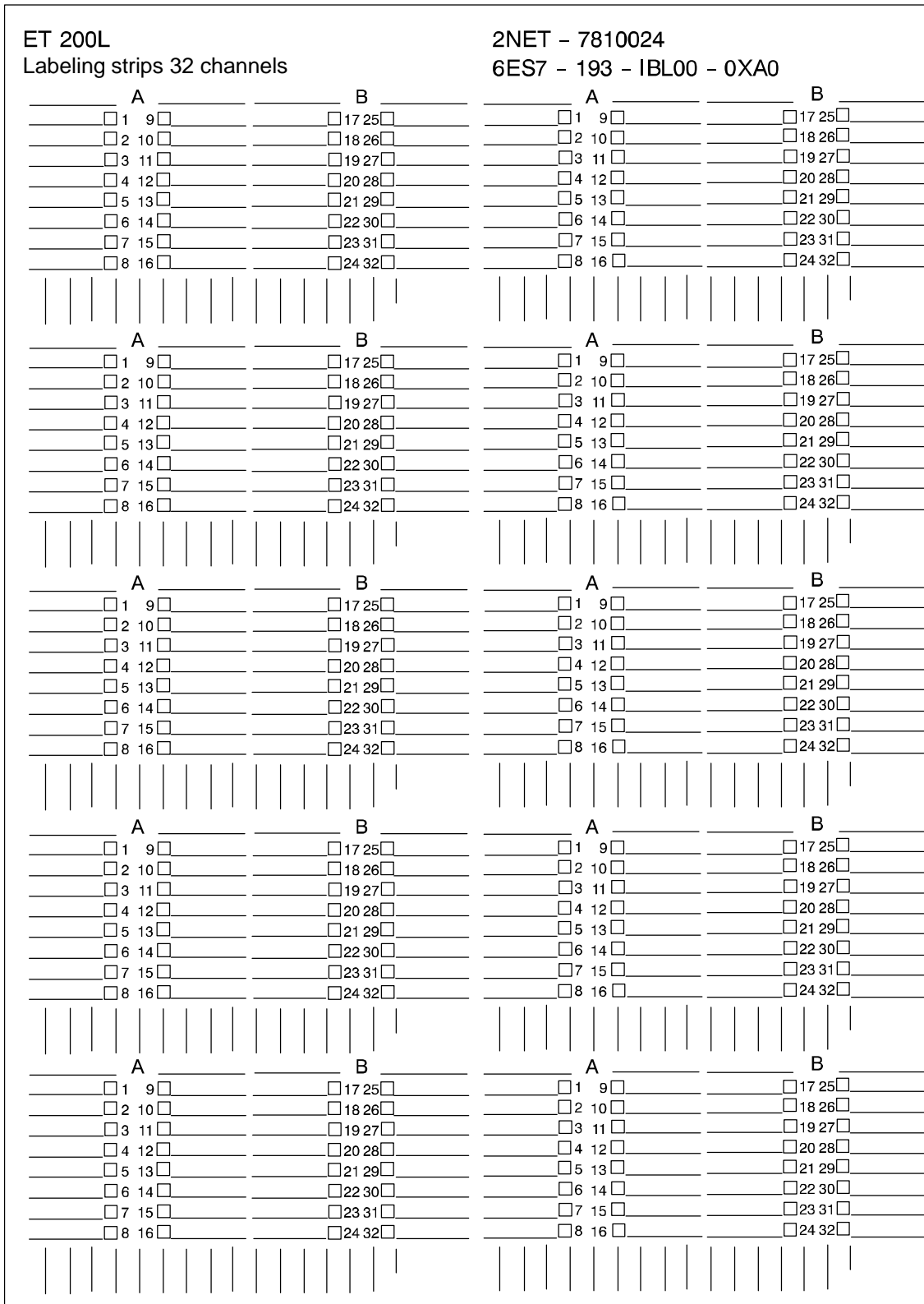

Figure A-2 Labeling Strips 6ES7193-1BL00-0XA0

A.2 Order Numbers for PROFIBUS Accessories

Introduction

In this section, we have listed the order numbers for PROFIBUS accessories which you require for the ET 200L.

Further, you will find notes on the different manuals you will require, depending on the PROFIBUS-DP master being used.

Network Components for the ET 200

Table A-4 lists all the network components for the ET 200L distributed I/O device which you may require in conjunction with the ET 200L.

Table A-4 Accessories for the ET 200 Distributed I/O Device

Accessories	Order Number
RS 485 repeater, PROFIBUS -DP, IP 20	6ES7972-0AA01-0XA0
PROFIBUS bus terminator (12 MBaud) (not for interface module IM-SC)	
• Anthracite (without programming port)	6ES7972-0BA12-0XA0
• Anthracite (with programming port)	6ES7972-0BB12-0XA0
PROFIBUS bus terminator (1.5 MBaud)	6ES7972-0CA34-0XA0
Bus cable (not for interface module IM-SC)	
• Normal	6XV1830-0AH10
• Drum cable	6XV1830-3BH10
• Direct-buried cable	6XV1830-3AH10
Optical link modules for glass fiber-optic cables	6GK1502-3CB10 6GK 502-4CB10
PROFIBUS drop cable	6ES7901-4BD00-0XA0

Manuals for STEP 7 and SIMATIC S7

You require one of the manuals listed in Table A-5 to program and commission the ET 200L with STEP 7.

Table A-5 Manuals for STEP 7 and SIMATIC S7

Manual	Contents
S7-300 Programmable Controller Hardware and Installation	Includes <ul style="list-style-type: none"> • Description of the PROFIBUS-DP interface of CPU 315-2 DP • Installing a PROFIBUS-DP network • Bus connector and RS 485 repeater
M7-300 Programmable Controller Hardware and Installation	Includes <ul style="list-style-type: none"> • Description of the PROFIBUS-DP interface in M7-300 • Installing a PROFIBUS-DP network • Bus connector and RS 485 repeater
S7-400, M7-400 Programmable Controllers Hardware and Installation	Includes <ul style="list-style-type: none"> • Description of the PROFIBUS-DP interface in S7-400 and M7-400 • Installing a PROFIBUS-DP network • Bus connector and RS 485 repeater
System software for S7-300 and S7-400 Program Design Programming manual	Includes Description of addressing and diagnostics on SIMATIC S7
System software for S7-300 and S7-400 System and Standard Functions Reference manual	Description of the SFCs in STEP 7

Manual for ET 200 on SIMATIC S5

You require one of the manuals listed in Table A-5 to program and commission the ET 200L with COM ET 200.

Table A-6 Manuals for ET 200 on SIMATIC S5

Manual	Order Number	Contents
ET 200 distributed I/O device	6ES5 998-3ES12	<ul style="list-style-type: none"> • Description of master interface IM 308-C for S5-115U/H, S5-135U and S5-155U/H • Description of the S5-95U with PROFIBUS-DP master interface • Handling COM ET 200 Windows • Handling FB IM308C

B

Type and Device Master Files

Type File

All the properties of a DP slave are stored in a type file.

You can integrate the type file of the ET 200L (Table B-4) in COM ET 200 as of Version 4.0, COM ET 200 Windows and STEP 7.

Device Master File

All slave-specific characteristics are stored in a device master file (GSD file). The structure of the device master file is laid down in *IEC 61784-1:2002 Ed1 CP 3/1*.

Configuration Software

The following table shows the version of the configuration software as of which the ET 200L are integrated.

Table B-1 Version der Projektier-Software

Order Number of the Module (6ES7 ... 0XB0)	COM ET 200 Windows as of Version	COM PROFIBUS as of Version	STEP 7 as of Version
131-1BH1	2.1	3.0	3.0
131-1BL01	2.1	3.0	3.0
132-1BH00	2.1	3.0	3.0
132-1BL00	2.1	3.0	3.0
133-1BL01	2.1	3.0	3.0

Most Important Characteristics

If you do not have the device master file in front of you, the most important characteristics of the ET 200L distributed I/O device are listed here in tabular form.

Table B-2 Data for PROFIBUS-DP

Characteristic	DP Keyword in Accordance with IEC 61784-1:2002 Ed1 CP 3/1	ET 200L
Manufacturer ID	Ident_Number	See Table B-4
Supports FMS	FMS_supp	No
Supports 9.6 kbps	9.6_supp	Yes
Supports 19.2 kbps	19.2_supp	Yes
Supports 93.75 kbps	93.75_supp	Yes
Supports 187.5 kbps	187.5_supp	Yes
Supports 500 kbps	500_supp	Yes
Supports 1.5 Mbps	1.5M_supp	Yes
Supports 3 Mbps	3M_supp	No
Supports 6 Mbps	6M_supp	No
Supports the FREEZE control command	Freeze_Mode_supp	Yes
Supports SYNC control command	Sync_Mode_supp	Yes
Supports automatic baud rate recognition	Auto_Baud_supp	Yes
PROFIBUS address modifiable using software	Set_Slave_Add_supp	No
User-specific parameterization data (default)	User_Prm_Data	Yes
Length of the user-specific data	User_Prm_Data_Len	5 bytes 5 × 00 _H
Modular device	Modular_Station	0
Maximum number of modules	Max_Module	0
Maximum number of inputs	Max_Input_Len	See Table B-3
Maximum number of outputs	Max_Output_Len	
Maximum number of inputs and outputs together	Max_Data_Len	
Central display of manufacturer-specific status and error messages	Unit_Diag_Bit	Not used
Assignment of values to texts in device-specific diagnostic field	Unit_Diag_Area	Not used
Identification of all modules of a modular DP slave	Module, End_Module	No
Assignment of manufacturer-specific error types to texts in channel-specific diagnostic field	Channel_Diag	No

Inputs and Outputs with the ET 200L

Table B-3 indicates the maximum number of inputs and outputs of the different ET 200L electronics blocks:

Table B-3 Maximum Number of Inputs and Outputs with the ET 200L

Electronics Block	Maximum Number of		
	Inputs (Bytes)	Outputs (Bytes)	Inputs and Outputs Together (Bytes)
L 16 DI DC 24 V	2	0	2
L 32 DI DC 24 V	4	0	4
L 16 DO DC 24 V/0.5 A	0	2	2
L 32 DO DC 24 V/0.5 A	0	4	4
L 16 DI/16 DO DC 24 V/0.5 A	2	2	4

DP Identifier

The various electronic blocks are distinguished by means of the DP identifier within PROFIBUS-DP. Table B-4 lists the DP identifiers for the ET 200L distributed I/O device.

Table B-4 DP Identifiers for the ET 200L

Electronics Block ET 200L	Order Number 6ES7 ... -0XB0	Name of Type File200	Manufacturer ID	DP Identifier		Consistency	Address Length (Bytes)	Address Area
				Slot 0	Slot 1			
L 16 DI DC 24 V	131-1BH01	SI0014AX ¹	0014 _H	000	017	Byte	2	Digital
L 32 DI DC 24 V	131-1BL01	SI0015AX ¹	0015 _H	000	019	Byte	4	Digital
L 16 DO DC 24 V/0.5 A	132-1BH00	SI0016AX ¹	0016 _H	033	000	Byte	2	Digital
L 32 DO DC 24 V/0.5 A	132-1BL00	SI0011AX ¹	0011 _H	035	000	Byte	4	Digital
L 16 DI/16 DO DC 24 V/0.5 A	133-1BL01	SI0017AX ¹	0017 _H	033	017	Byte	2 × 2 ²	Digital

¹ "X" stands for a language-independent version

² Two bytes each for the input and output ranges

Guidelines for Handling Electrostatically Sensitive Devices (ESD)

C

Summary of Sections

In Section	You will find	On Page
C.1	What is ESD?	C-2
C.2	Electrostatic Charging of Persons	C-3
C.3	General Protective Measures Against Electrostatic Discharge Damage	C-4

C.1 What is ESD?

Definition

All electronic modules are equipped with large-scale integrated ICs or components. Due to their design, these electronic elements are very sensitive to overvoltages and thus to any electrostatic discharge.

These **E**lectrostatically **S**ensitive **D**evelopments are commonly referred to by the abbreviation **ESD**.

Electrostatically sensitive devices are labeled with the following symbol:

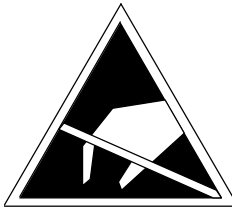

Caution

Electrostatically sensitive devices are subject to voltages that are far below the voltage values that can still be perceived by human beings. These voltages are present if you touch a component or the electrical connections of a module without previously being electrostatically discharged. In most cases, the damage caused by an overvoltage is not immediately noticeable and results in total damage only after a prolonged period of operation.

C.2 Electrostatic Charging of Persons

Charging

Every person with a non-conductive connection to the electrical potential of its surroundings can be electrostatically charged.

Figure C-1 shows you the maximum values for electrostatic voltages which can build up on a person coming into contact with the materials indicated in the figure. These values are in conformity with the specifications of IEC 801-2.

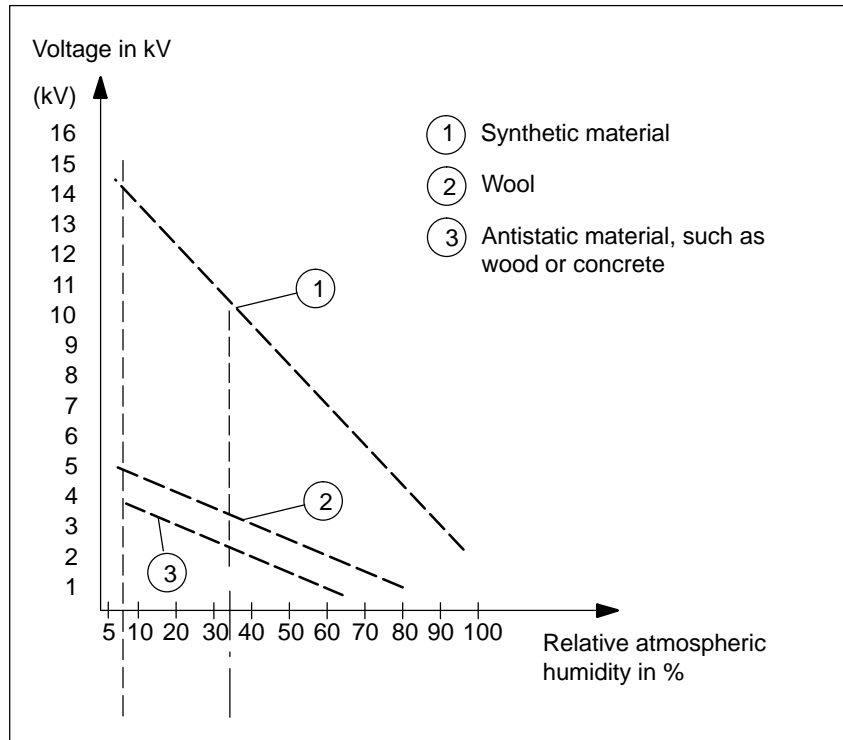

Figure C-1 Electrostatic Voltages which can Build up on a Person

C.3 General Protective Measures Against Electrostatic Discharge Damage

Ensure Sufficient Grounding

Make sure the personnel, working surfaces and packaging are sufficiently grounded when handling electrostatically sensitive devices. You can thus avoid electrostatic charging.

Avoid Direct Contact

You should touch electrostatically sensitive devices only if it is unavoidable (for example, during maintenance work). Hold modules without touching the pins of components or printed conductors. In this way, the discharged energy cannot affect the sensitive devices.

If you have to carry out measurements on a module, you must discharge your body before you start the measurement by touching grounded metallic parts. Use grounded measuring devices only.

Glossary

A

Aggregate current The aggregate of the currents of all the output channels of a digital output module.

B

Baud rate The baud rate is the speed at which data is transmitted. It specifies the number of bits transmitted per second (baud rate = bit rate).

Baud rates of 9.6 kbps to 1.5 Mbps are possible with the ET 200L.

Bus The common transmission path to which all nodes are connected. It has two defined ends.

In the case of the ET 200, the bus is a two-wire cable or a fiber-optic cable.

Bus connector The physical link between the bus nodes and the bus cable.

In the case of the ET 200, there is a bus connector with and without connections for the programming unit and with IP 20 and IP 65 degrees of protection.

C

Chassis ground The chassis ground is the totality of all the interconnected inactive parts of a piece of equipment that cannot carry hazardous contact voltage even in the event of a fault.

Configuration This refers to the configuration of individual modules in a distributed I/O system.

Consistent data	Data that belongs together by content is referred to as consistent data. The data must not be corrupted by being read at different times.
D	
Default setting	The default setting is a basic setting that applies unless another value is set (i.e. parameterized).
Device master file	All the properties of a DP slave are stored in a device master file. The format of the device master file is stored in the <i>IEC 61784-1:2002 Ed1 CP 3/1</i> standard.
Distributed I/O devices	<p>These are input/output units that are installed in a distributed configuration at some distance from the CPU rather than in the central rack. For example:</p> <ul style="list-style-type: none">• ET 200L• ET 200S• ET 200M• Other DP slaves manufactured by Siemens or another company <p>The distributed I/O devices are connected to the DP master via the PROFIBUS-DP bus.</p>
Diagnostics	<p>Diagnostics is the detection, localization, categorization, indication and analysis of errors, faults, malfunctions and messages.</p> <p>Diagnostics provides monitoring functions that run automatically while a plant is operating. This enhances the availability of a plant by reducing setup and stoppage times.</p>
DP master	A → master whose behavior complies with <i>IEC 61784-1:2002 Ed1 CP 3/1</i> is referred to as a DP master.
DP slave	A → slave that runs on the PROFIBUS using the PROFIBUS-DP protocol and whose behavior complies with <i>IEC 61784-1:2002 Ed1 CP 3/1</i> is referred to as a DP slave.
DP standard	The DP standard is the bus protocol of the ET 200 distributed I/O system. It complies with <i>IEC 61784-1:2002 Ed1 CP 3/1</i> .

E

Electromagnetic compatibility

Electromagnetic compatibility is the capacity of electrical equipment to work correctly in a specified environment without negatively affecting the functioning of other equipment in the vicinity.

Equipotential bonding

An electrical connection (equipotential bonding conductor) that brings the bodies of electrical apparatus and extraneous conductive bodies to the same or approximately the same potential to prevent interfering or hazardous voltages between these bodies.

ET 200

The ET 200 distributed I/O system with the PROFIBUS-DP protocol is a bus for connecting distributed I/O devices to a CPU or an adequate DP master. A feature of ET 200 are its short response times, since only a small volume of data (bytes) is transmitted.

ET 200 complies with the PROFIBUS standard, *IEC 61784-1:2002 Ed1 CP 3/1*.

ET 200 operates on the master/slave principle. The IM 308-C master interface module or the CPU 315-2 DP can be DP masters, for example.

The distributed I/O devices ET 200B, ET 200C, ET 200M, ET 200L or ET 200U can be DP slaves, as can other DP slaves made by Siemens or other manufacturers.

F

Floating

In the case of input/output modules, the reference potentials of control and load circuits are isolated (e.g. by means of an optocoupler, a relay contact or a transformer). Input/output circuits can be connected to common potential.

FREEZE

This is a control command of the DP master to a group of DP slaves.

When a DP slave receives the FREEZE control command, it freezes the current status of the **inputs** and transfers them at intervals to the DP master.

The DP slave freezes the status of the **inputs** again after each subsequent FREEZE control command.

The input data is not transmitted from the DP slave to the DP master at intervals again until the DP master sends the UNFREEZE control command.

Function grounding

Grounding with the sole purpose of ensuring that the electrical equipment functions properly. By means of function grounding, interference voltages that would otherwise result in inadmissible interference to the equipment are short-circuited.

G

Ground The conductive earth whose electrical potential can be set to zero at any point.
Around grounding electrodes, the earth may have a potential other than zero. The term "reference ground" is frequently used in this connection.

Grounding Grounding means to connect an electrically conductive part to the grounding electrode by means of a grounding system.

I

IP 20 DIN 40050 degree of protection: Protection against finger contact and against solid foreign matter more than 12 mm in diameter.

L

Load power supply unit A power supply unit for the ET 200L distributed I/O device and the process devices connected to it.

M

Master When it is in possession of the token, a master can send data to other nodes and request data from other nodes (synonymous with active node).
The CPU 315-2 DP and the IM 308-C can be → DP masters, for example.

N

Node A device that can send, receive or amplify data via the bus (e.g. a DP master, DP slave, RS 485 repeater or active star coupler).

Non-isolated In the case of non-isolated input/output modules, the reference potentials of control and load circuits are electrically connected.

P

Parameterization	Parameterization is the passing of slave parameters from the DP master to the DP slave.
Parameters, dynamic	In contrast to static parameters, the dynamic parameters of modules can be changed during operation by calling an SFC in the application program (e.g. limit values of an analog signal input module).
Parameters, static	In contrast to dynamic parameters, the static parameters of modules cannot be changed by means of the application program; they can only be changed by means of STEP 7 (not in RUN mode). An example is the input delay of a digital signal input module.
Programmable logic controller	A programmable logic controller consists of at least one CPU, a number of input and output modules, and operating and monitoring equipment.
PROFIBUS	<p>PROcess Field BUS, the German process and field bus standard defined in the PROFIBUS standard (<i>IEC 61784-1:2002 Ed1 CP 3/1</i>). It specifies functional, electrical and mechanical characteristics for a bit-serial field bus system.</p> <p>PROFIBUS is available with the following protocols: DP (= distributed I/O), FMS (= Fieldbus Message Specification), PA (= Process Automation) or TF (= Technological Functions).</p>
PROFIBUS address	<p>Each bus node must have a PROFIBUS address (station number) so that it can be identified uniquely on the PROFIBUS.</p> <p>PC/PG or the ET 200-Handheld have the PROFIBUS address "0".</p> <p>The PROFIBUS addresses 1 to 99 are permissible for the ET 200L distributed I/O device.</p>
PROFIBUS-DP	A draft standard (<i>IEC 61784-1:2002 Ed1 CP 3/1</i>) on which the ET 200 distributed I/O system is based.

R

Reference potential	The potential on the basis of which the voltages of the circuits involved can be observed and/or measured.
----------------------------	--

S

Slave

A slave cannot exchange data with a → master unless requested by the latter to do so.

Examples of slaves are all DP slaves, such as ET 200B, ET 200L and ET 200M.

SYNC

SYNC is a control command of the DP master to a group of DP slaves.

By means of the SYNC control command, the DP master causes the DP slave to freeze the statuses of the **outputs** at their current value. In the subsequent frames, the DP slave saves the output data, but the statuses of the outputs remain unchanged.

After each SYNC control command, the DP slave sets the outputs it has saved as output data.

The outputs are not periodically updated again until the DP master sends the UNSYNC control command.

T

Type file

A file required by the configuration software (e.g. COM ET 200 Windows) for configuring a DP slave. The type file contains definitions of the slave-specific properties, such as the number of inputs and outputs, the number of diagnostic bytes, and SYNC capability.

U

Ungrounded

Not having a conductive connection to → ground.

Index

Numbers

24 VDC supply, 3-3

A

Accessories, order number, A-5
Aggregate current, Glossary-1
Applications, 1-3
Assignment of EB to TB, 8-1

B

Baud rate, **B-3**, Glossary-1
BF, 5-2
Block I/O device, ET 200L, 1-3
Bridging voltage drops, 6-9
Bus, Glossary-1
Bus cable, order number, A-5
Bus connector, Glossary-1
 clipping on, 3-11
 order number, A-5

C

Cable cross-sections, 3-8
Cables
 insulation stripping length, 3-8
 number, 3-8
CE marking, 6-2
Certification, 6-2
Changes, since the previous versions of the manual, iii
Characteristics
 electronics block, 1-5
 terminal block, 1-5
Chassis ground, Glossary-1
Climatic environmental conditions, 6-7
COM ET 200 Windows, 4-1
COM PROFIBUS, 4-1

Components of an ET 200L, 1-7
Configuration, Glossary-1
Configuration software, 4-1
Connect, terminal block, 3-10
Connecting cables, tightening torque, 3-8
Consistent data, Glossary-2
CSA certification, 6-3

D

Data exchange, 4-3
Definition
 electromagnetic compatibility, 6-4
 grounded supply, 3-4
 manufacturer ID, 5-6
 master PROFIBUS address, 5-6
 ET 200L, 1-3
 station status, 5-5
Degree of protection, 6-8
Device master file, B-1, Glossary-2
Diagnostics, 5-1, Glossary-2
 definition, 5-3
 DP slave, 5-4
 using LEDs, 5-2
Direct-buried cable, order number, A-5
Disassemble
 electronics block, 2-5
 supplementary terminal, 2-3
 terminal block, 2-4
Display
 LED, 5-2
 status, 5-2
Disposal, iii
Distributed I/O device, Glossary-2
DP master, Glossary-2
DP slave, Glossary-2
DP standard, Glossary-2
DP identifier, B-4
Drum cable, order number, A-5

E

- EB L 16 DI DC 24 V, 8-2
 - block diagram, 8-3
 - technical data, 8-4
 - view, 8-2
- EB L 16 DI/16 DO DC 24 V/0.5 A, 8-14
 - block diagram, 8-15
 - technical data, 8-15
 - view, 8-14
- EB L 16 DO DC 24 V/0.5 A, 8-5
 - block diagram, 8-6
 - technical data, 8-6
 - view, 8-5
- EB L 32 DI DC 24 V, 8-8
 - block diagram, 8-9
 - technical data, 8-10
 - view, 8-8
- EB L 32 DO DC 24 V/0.5 A, 8-11
 - block diagram, 8-12
 - technical data, 8-12
 - view, 8-11
- Electrical installation, configuring, 3-4
- Electrical phenomena, protection against, 3-3
- Electromagnetic compatibility, 6-4
- Electronics block
 - characteristics, 1-5
 - disassembling, 2-5
 - L 16 DI DC 24 V, 8-2
 - L 16 DI/16 DO DC 24 V/0.5 A, 8-14
 - L 16 DO DC 24 V/0.5 A, 8-5
 - L 32 DI DC 24 V, 8-8
 - L 32 DO DC 24 V/0.5 A, 8-11
 - order number, A-2
- EMC, 3-5
- EMERGENCY STOP devices, 3-2
- Emission of radio interference, 6-5
- Equipotential bonding, Glossary-3
- ET 200, Glossary-3
 - components, 1-2
 - incorporated modules, 1-6
 - what is the ET 200, 1-2
- ET 200 distributed I/O system, 1-2
- ET 200L
 - block I/O device, 1-3
 - characteristics
 - electronics block, 1-5
 - terminal block, 1-5
 - components, 1-7
 - definition, 1-3
 - view, 1-6
 - wiring, 3-10

- ET 200L and Smart Connect, what is the
ET 200L and Smart Connect, 1-3

F

- Floating, Glossary-3
- FM approval, 6-3
- FREEZE, Glossary-3
- Function grounding, Glossary-3

G

- General technical data, ET 200L, 6-1
- Ground, Glossary-4
- Grounded supply, 3-4
- Grounding, Glossary-4
- Guide, iii

I

- IEC 1131, 6-2
- Installation, 2-1
 - electronics block, 2-5
 - requirements, 2-2
 - supplementary terminal, 2-3
 - terminal block, 2-3
- Installation, ET 200L, sequence, 2-1
- Insulation stripping length, ET 200L, 3-8
- Insulation test, 6-8
- IP 20, Glossary-4

L

- Label, 3-11
- Labeling strip, order number, A-2
- Labeling strip, ET 200L, A-2
- LED, 5-2
 - BF, 5-2
 - ON, 5-2
- Load circuit, 3-5
- Load current power supply, characteristics, 3-5
- Load power supply unit, Glossary-4

M

Manual
 order number
 S5, A-6
 S7, A-6
 purpose of, iii
Manufacturer ID, B-4
 definition, 5-6
 structure, 5-6
Master, Glossary-4
Master PROFIBUS address
 definition, 5-6
 structure, 5-6
Mechanical environmental conditions, 6-7

N

Node, Glossary-4
Non-isolated, Glossary-4

O

ON, 5-2
Operating regulations, 3-2
Optical link module, order number, A-5
Order number, A-1
 accessories for PROFIBUS-DP, A-5
 bus cable, A-5
 bus connector, A-5
 direct-buried cable, A-5
 drum cable, A-5
 electronics block, A-2
 labeling strip, A-2
 manual
 S5, A-6
 S7, A-6
 optical link module, A-5
 PROFIBUS drop cable, A-5
 RS 485 repeater, A-5
 supplementary terminal, A-2
 terminal block, A-2
Overall installation in TN system, 3-6

P

Parameterization, Glossary-5
Power supply, 1-4
Preface, iii
Previous version, of the manual, iii

Product overview, 1-1
PROFIBUS, Glossary-5
 address, Glossary-5
 location of rotary switch, 2-6
 address modifying, 2-6
 address validity, 2-6
PROFIBUS address, setting, 2-6
PROFIBUS drop cable, order number, A-5
PROFIBUS-DP terminal connection, 3-12
PROFIBUS-DP, 1-2, Glossary-5
Programmable logic controller, Glossary-5
Protection against electrical phenomena, 3-3
Protective measures, 3-4
PS. *See* Power supply
Pulse-shaped interference, 6-4

R

Rail, 1-4
Rated voltage, 6-9
Recycling, iii
Reference potential, Glossary-5
Rotary switch, 2-6
RS 485 repeater, order number, A-5
Rules, general, 3-2

S

Safety class, 6-8
Safety regulations, 3-2
Scope of this manual, iii
Service & Support on the Internet, iv
Shipping conditions, 6-6
Sine-shaped interference, 6-5
Slave, 5-3, Glossary-6
 diagnosis, structure, 5-4
 requesting, 5-4
Standards, 6-2
Standards and certification, 6-2
Start-up, 4-3
 of plant, 3-2
Station status
 definition, 5-5
 structure
 Part 1, 5-5
 Part 2, 5-6
 Part 3, 5-6
STEP 7, 4-1
Storage conditions, 6-6
Structure of the slave diagnosis, 5-4

Supplementary terminal, 7-7
 dimension drawing, 7-8
 disassembling, 2-3
 installing, 2-3
 order number, A-2
 versions supplied, 7-7
Supply isolating switch, 3-2
Supply voltage, 3-2
SYNC, Glossary-6

T

TB 16L, 7-2
 dimension drawing, 7-2
 pinout, 7-3
 technical data, 7-3
TB 32L, 7-4
 dimension drawing, 7-5
 pinout, 7-6
 technical data, 7-6
Technical data
 climatic environmental conditions, 6-7
 data of the individual components, 8-1
 electromagnetic compatibility, 6-4
 general, ET 200L, 6-1
 mechanical environmental conditions, 6-7
 transport and storage conditions, 6-6
Technical Support, iv
Terminal block
 (spring terminal) wiring, 3-9
 characteristics, 1-5
 connecting, 3-10
 disassembling, 2-4
 installing, 2-3
 order number, A-2
 TB 16L, 7-2
 TB 32L, 7-4

Terminal connection model, 3-11
Test voltage, 6-8
Tightening torque, connecting cables, 3-8
TN system, 3-6
Training center, iv
Type file, **B-1**, Glossary-6
Type files, device master files, B-1

U

UL recognition, 6-3
Ungrounded, Glossary-6

V

View of ET 200L, 1-6
Voltage drop, 6-9

W

Wiring
 ET 200L and Smart Connect, 3-1
 terminal block (spring terminal), 3-9
Wiring rules, SC, 3-8