

TLP251

INVERTER FOR AIR CONDITIONOR
 INDUCTION HEATING
 TRANSISTOR INVERTER
 POWER MOS FET GATE DRIVE
 IGBT GATE DRIVE

The TOSHIBA TLP251 consists of a GaAlAs light emitting diode and a integrated photodetector.

This unit is 8-lead DIP package.

TLP251 is suitable for gate driving circuit of IGBT or power MOS FET. Especially TLP251 is capable of "direct" gate drive of lower power IGBTs. (~15A)

- Input Threshold Current : $I_F = 5\text{mA}$ (Max.)
- Supply Current (I_{CC}) : 11mA (Max.)
- Supply Voltage (V_{CC}) : 10–35V
- Output Current (I_O) : $\pm 0.4\text{A}$ (Max.)
- Switching Time (t_{pLH}/t_{pHL}) : $1\mu\text{s}$ (Max.)
- Isolation Voltage : 2500Vrms (Min.)
- UL Recognized : UL1577, File No. E67349

Unit in mm

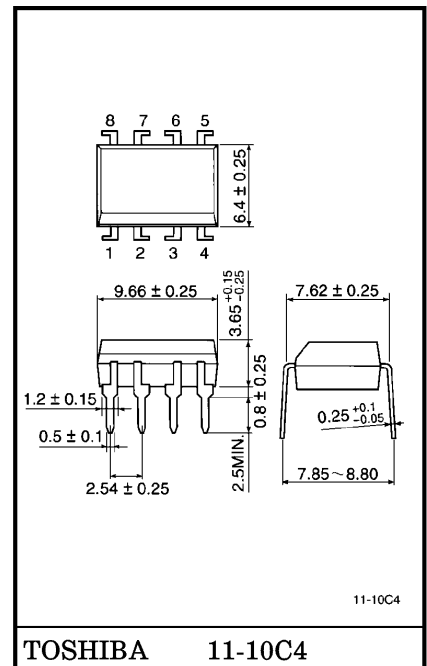

Weight : 0.54g

PIN CONFIGURATION (TOP VIEW)

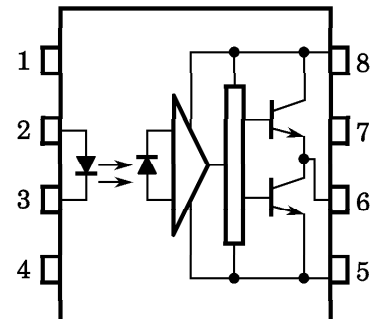

- 1 : N.C.
- 2 : ANODE
- 3 : CATHODE
- 4 : N.C.
- 5 : GND
- 6 : V_O (OUTPUT)
- 7 : N.C.
- 8 : V_{CC}

SCHMATIC

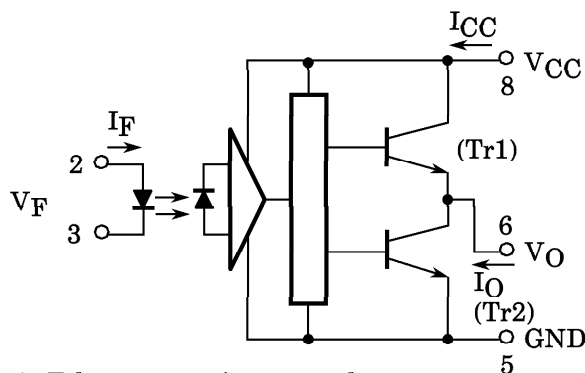

A $0.1\mu\text{F}$ bypass capacitor must be connected between pin 8 and 5 (See Note 5).

TRUTH TABLE

| | | Tr1 | Tr2 |
|-----------|-----|-----|-----|
| Input LED | ON | ON | OFF |
| | OFF | OFF | ON |

MAXIMUM RATINGS (Ta = 25°C)

| CHARACTERISTIC | | SYMBOL | RATING | UNIT | |
|---|--|------------------------------|----------|---------|---|
| LED | Forward Current | I_F | 20 | mA | |
| | Forward Current Derating (Ta ≥ 70°C) | $\Delta I_F / \Delta T_a$ | -0.36 | mA / °C | |
| | Peak Transient Forward Current (Note 1) | I_{FPT} | 1 | A | |
| | Reverse Voltage | V_R | 5 | V | |
| | Junction Temperature | T_j | 125 | °C | |
| DETECTOR | “H” Peak Output Current ($P_W \leq 2.0 \mu s$, $f \leq 15 \text{kHz}$) (Note 2) | I_{OPH} | -0.4 | A | |
| | “L” Peak Output Current ($P_W \leq 2.0 \mu s$, $f \leq 15 \text{kHz}$) (Note 2) | I_{OPL} | 0.4 | A | |
| | Output Voltage | (Ta ≤ 70°C) | V_O | 35 | V |
| | | (Ta = 85°C) | | 24 | |
| | Supply Voltage | (Ta ≤ 70°C) | V_{CC} | 35 | V |
| | | (Ta = 85°C) | | 24 | |
| | Output Voltage Derating (Ta ≥ 70°C) | $\Delta V_O / \Delta T_a$ | -0.73 | V / °C | |
| | Supply Voltage Derating (Ta ≥ 70°C) | $\Delta V_{CC} / \Delta T_a$ | -0.73 | V / °C | |
| Junction Temperature | T_j | 125 | °C | | |
| Operating Frequency (Note 3) | f | 25 | kHz | | |
| Operating Temperature Range | T_{opr} | -20~85 | °C | | |
| Storage Temperature Range | T_{stg} | -55~125 | °C | | |
| Lead Soldering Temperature (10s) | T_{sol} | 260 | °C | | |
| Isolation Voltage (AC, 1min., R.H. ≤ 60%) (Note 4) | BV_S | 2500 | Vrms | | |

(Note 1) Pulse width $P_W \leq 1 \mu s$, 300pps

(Note 2) Exponential Waveform

(Note 3) Exponential Waveform, $I_{OPH} \leq -0.25A (\leq 2.0 \mu s)$, $I_{OPL} \leq +0.25A (\leq 2.0 \mu s)$

(Note 4) Device considered a two terminal device : pins 1,2,3 and 4 shorted together, and pins 5, 6, 7 and 8 shorted together.

(Note 5) A ceramic capacitor (0.1 μ F) should be connected from pin 8 to pin 5 to stabilize the operation of the high gain linear amplifier. Failure to provide the bypassing may impair the switching property. The total lead length between capacitor and coupler should not exceed 1cm.

RECOMMENDED OPERATING CONDITIONS

| CHARACTERISTIC | SYMBOL | MIN. | TYP. | MAX. | UNIT |
|-----------------------|-------------------|------|------|-----------|------|
| Input Current, ON | I_F (ON) | 7 | 8 | 10 | mA |
| Input Voltage, OFF | V_F (OFF) | 0 | — | 0.8 | V |
| Supply Voltage | V_{CC} | 10 | — | 30 20 | V |
| Peak Output Current | I_{OPH}/I_{OPL} | — | — | ± 0.1 | A |
| Operating Temperature | T_{opr} | -20 | 25 | 70 85 | °C |

ELECTRICAL CHARACTERISTICS ($T_a = -20 \sim 70^\circ\text{C}$, Unless otherwise specified)

| CHARACTERISTIC | SYMBOL | TEST CIR-CUIT | TEST CONDITION | MIN. | TYP.* | MAX. | UNIT | | |
|--|---------------------------|---------------|--|--|--|-------|---------------|----|---|
| Input Forward Voltage | V_F | — | $I_F = 10\text{mA}$, $T_a = 25^\circ\text{C}$ | — | 1.6 | 1.8 | V | | |
| Temperature Coefficient of Forward Voltage | $\Delta V_F / \Delta T_a$ | — | $I_F = 10\text{mA}$ | — | -2.0 | — | mV / °C | | |
| Input Reverse Current | I_R | — | $V_R = 5\text{V}$, $T_a = 25^\circ\text{C}$ | — | — | 10 | μA | | |
| Input Capacitance | C_T | — | $V = 0$, $f = 1\text{MHz}$, $T_a = 25^\circ\text{C}$ | — | 45 | 250 | pF | | |
| Output Current | “H” Level | I_{OPH} | 3 | $V_{CC} = 30\text{V}$ (*1) | $I_F = 10\text{mA}$ $V_{8-6} = 4\text{V}$ | -0.1 | -0.25 | — | A |
| | “L” Level | I_{OPL} | 2 | | $I_F = 0$ $V_{6-5} = 2.5\text{V}$ | 0.1 | 0.2 | | |
| Output Voltage | “H” Level | V_{OH} | 4 | $V_{CC1} = +15\text{V}$, $V_{EE1} = -15\text{V}$ $R_L = 200\Omega$, $I_F = 5\text{mA}$ | 11 | 13.2 | — | V | |
| | “L” Level | V_{OL} | 5 | $V_{CC1} = +15\text{V}$, $V_{EE1} = -15\text{V}$ $R_L = 200\Omega$, $V_F = 0.8\text{V}$ | — | -14.5 | -12.5 | | |
| Supply Current | “H” Level | I_{CCH} | — | $V_{CC} = 30\text{V}$, $I_F = 10\text{mA}$ $T_a = 25^\circ\text{C}$ | — | 7.5 | — | mA | |
| | | | | $V_{CC} = 30\text{V}$, $I_F = 10\text{mA}$ | — | — | 11 | | |
| | “L” Level | I_{CCL} | — | $V_{CC} = 30\text{V}$, $I_F = 0\text{mA}$ $T_a = 25^\circ\text{C}$ | — | 8 | — | | |
| | | | | $V_{CC} = 30\text{V}$, $I_F = 0\text{mA}$ | — | — | 11 | | |
| Threshold Input Current | “Output L→H” | I_{FLH} | — | $V_{CC1} = +15\text{V}$, $V_{EE1} = -15\text{V}$ $R_L = 200\Omega$, $V_O > 0\text{V}$ | — | 1.2 | 5 | mA | |
| Threshold Input Voltage | “Output H→L” | V_{FHL} | — | $V_{CC1} = +15\text{V}$, $V_{EE1} = -15\text{V}$ $R_L = 200\Omega$, $V_O < 0\text{V}$ | 0.8 | — | — | V | |
| Supply Voltage | V_{CC} | — | — | 10 | — | 35 | V | | |
| Capacitance (Input-Output) | C_s | — | $V_s = 0$, $f = 1\text{MHz}$ $T_a = 25^\circ\text{C}$ | — | 1.0 | 2.0 | pF | | |
| Resistance (Input-Output) | R_s | — | $V_s = 500\text{V}$, $T_a = 25^\circ\text{C}$ $R.H. \leq 60\%$ | 1×10^{12} | 10^{14} | — | Ω | | |

* All typical values are at $T_a = 25^\circ\text{C}$ (*1) : Duration of I_O time $\leq 50\mu\text{s}$

SWITCHING CHARACTERISTICS (Ta = -20~70°C, Unless otherwise specified)

| CHARACTERISTIC | | SYMBOL | TEST CIR-CUIT | TEST CONDITION | MIN. | TYP.* | MAX. | UNIT |
|---|-----|------------------|---------------|---|-------|-------|------|--------|
| Propagation Delay Time | L→H | t _{pLH} | 6 | I _F = 8mA V _{CC1} = +15V, V _{EE1} = -15V R _L = 200Ω | — | 0.25 | 1.0 | μs |
| | H→L | t _{pHL} | | | — | 0.25 | 1.0 | |
| Output Rise Time | | t _r | | | — | — | — | |
| Output Fall Time | | t _f | | | — | — | — | |
| Common Mode Transient Immunity at High Level Output | | C _{MH} | 7 | V _{CM} = 600V, I _F = 8mA V _{CC} = 30V, Ta = 25°C | -5000 | — | — | V / μs |
| Common Mode Transient Immunity at Low Level Output | | C _M L | 7 | V _{CM} = 600V, I _F = 0mA V _{CC} = 30V, Ta = 25°C | 5000 | — | — | V / μs |

* All typical values are at Ta = 25°C

TEST CIRCUIT 1 :

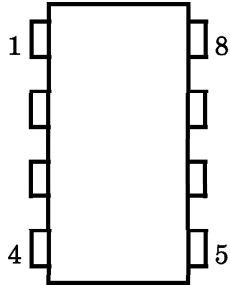

TEST CIRCUIT 2 : I_{OPL}

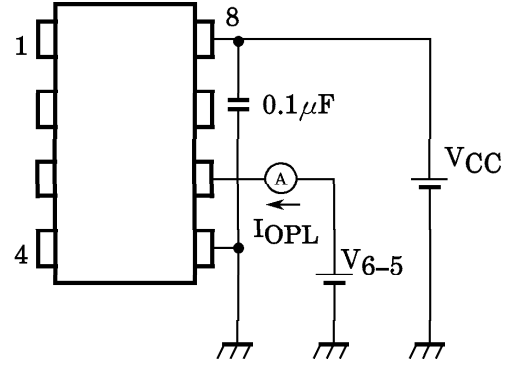

TEST CIRCUIT 3 : I_{OPH}

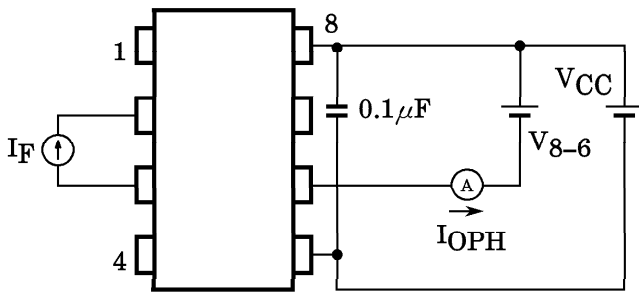

TEST CIRCUIT 4 : V_{OH}

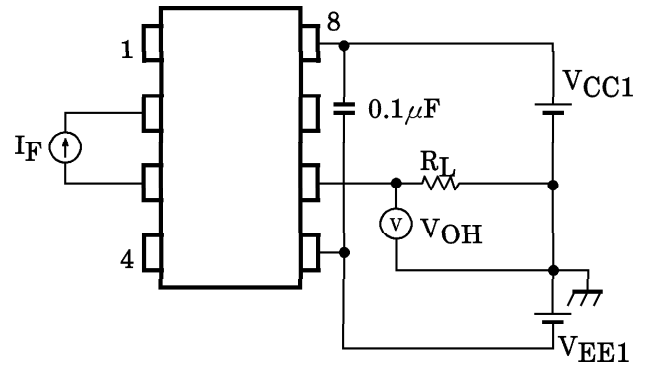

TEST CIRCUIT 5 : V_{OL}

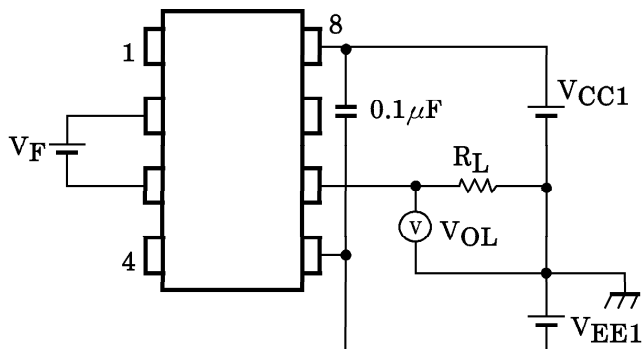

TEST CIRCUIT 6 : t_{pLH} , t_{pHL} , t_r , t_f

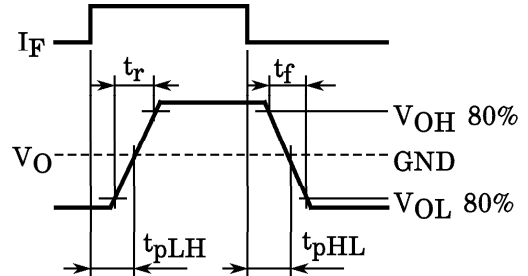
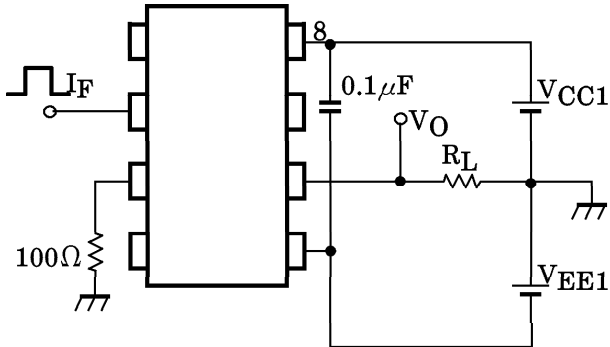

TEST CIRCUIT 7 : C_{MH} , C_{ML}

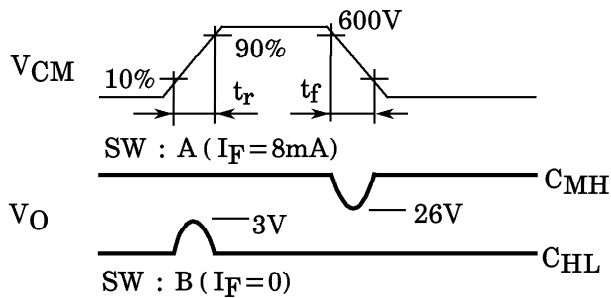
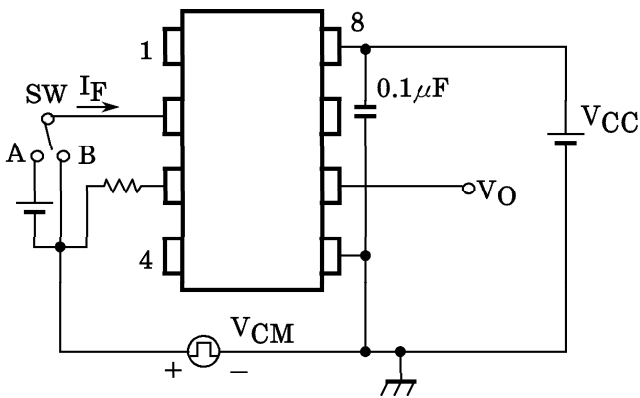

$$C_{ML} = \frac{480(V)}{t_r(\mu s)}$$

$$C_{MH} = \frac{480(V)}{t_f(\mu s)}$$

C_{ML} (C_{MH}) is the maximum rate of rise (fall) of the common mode voltage that can be sustained with the output voltage in the low (high) state.

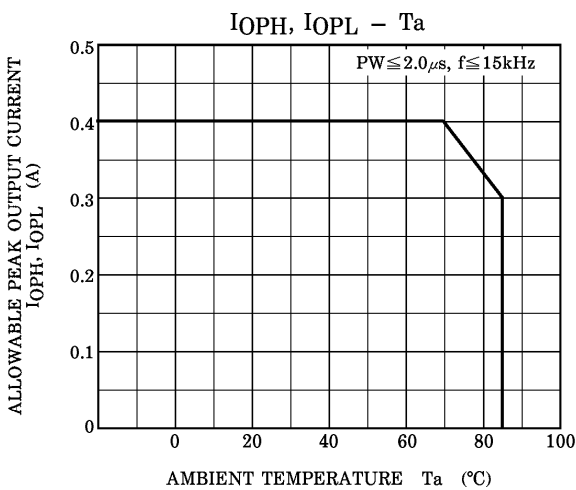
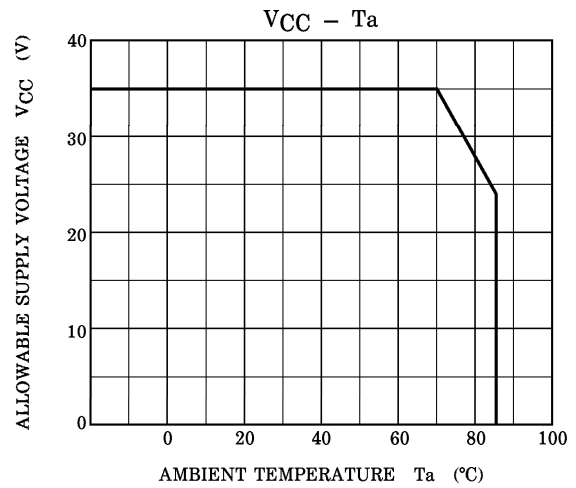
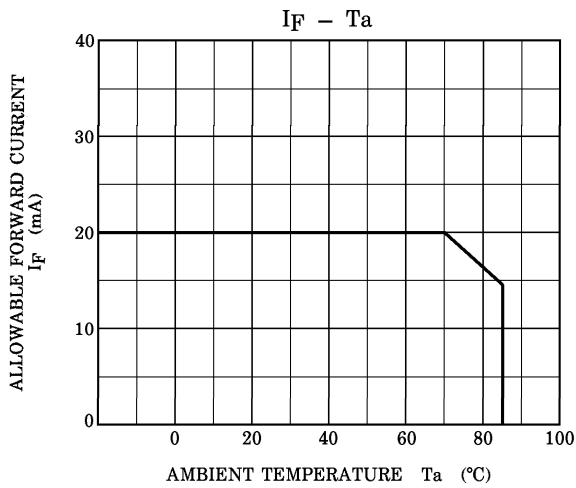
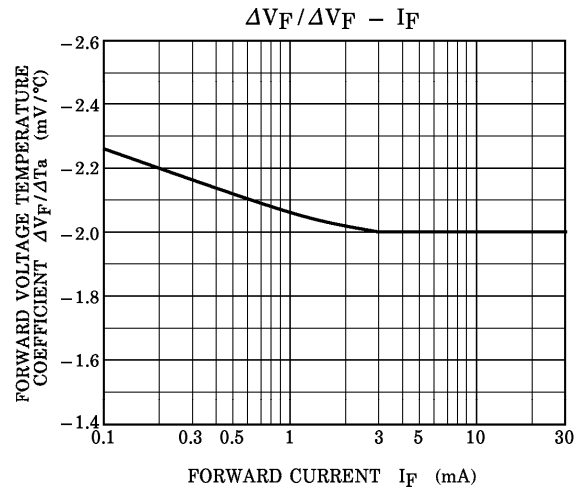
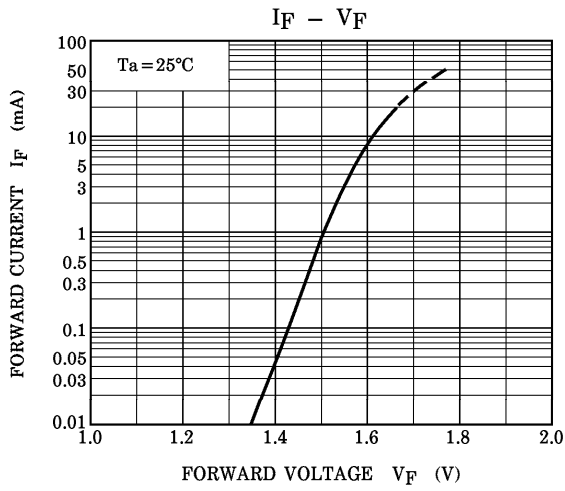

RESTRICTIONS ON PRODUCT USE

000707EBC

- TOSHIBA is continually working to improve the quality and reliability of its products. Nevertheless, semiconductor devices in general can malfunction or fail due to their inherent electrical sensitivity and vulnerability to physical stress. It is the responsibility of the buyer, when utilizing TOSHIBA products, to comply with the standards of safety in making a safe design for the entire system, and to avoid situations in which a malfunction or failure of such TOSHIBA products could cause loss of human life, bodily injury or damage to property. In developing your designs, please ensure that TOSHIBA products are used within specified operating ranges as set forth in the most recent TOSHIBA products specifications. Also, please keep in mind the precautions and conditions set forth in the "Handling Guide for Semiconductor Devices," or "TOSHIBA Semiconductor Reliability Handbook" etc..
- The TOSHIBA products listed in this document are intended for usage in general electronics applications (computer, personal equipment, office equipment, measuring equipment, industrial robotics, domestic appliances, etc.). These TOSHIBA products are neither intended nor warranted for usage in equipment that requires extraordinarily high quality and/or reliability or a malfunction or failure of which may cause loss of human life or bodily injury ("Unintended Usage"). Unintended Usage include atomic energy control instruments, airplane or spaceship instruments, transportation instruments, traffic signal instruments, combustion control instruments, medical instruments, all types of safety devices, etc.. Unintended Usage of TOSHIBA products listed in this document shall be made at the customer's own risk.
- Gallium arsenide (GaAs) is a substance used in the products described in this document. GaAs dust and fumes are toxic. Do not break, cut or pulverize the product, or use chemicals to dissolve them. When disposing of the products, follow the appropriate regulations. Do not dispose of the products with other industrial waste or with domestic garbage.
- The products described in this document are subject to the foreign exchange and foreign trade laws.
- The information contained herein is presented only as a guide for the applications of our products. No responsibility is assumed by TOSHIBA CORPORATION for any infringements of intellectual property or other rights of the third parties which may result from its use. No license is granted by implication or otherwise under any intellectual property or other rights of TOSHIBA CORPORATION or others.
- The information contained herein is subject to change without notice.